

LINTRACK features

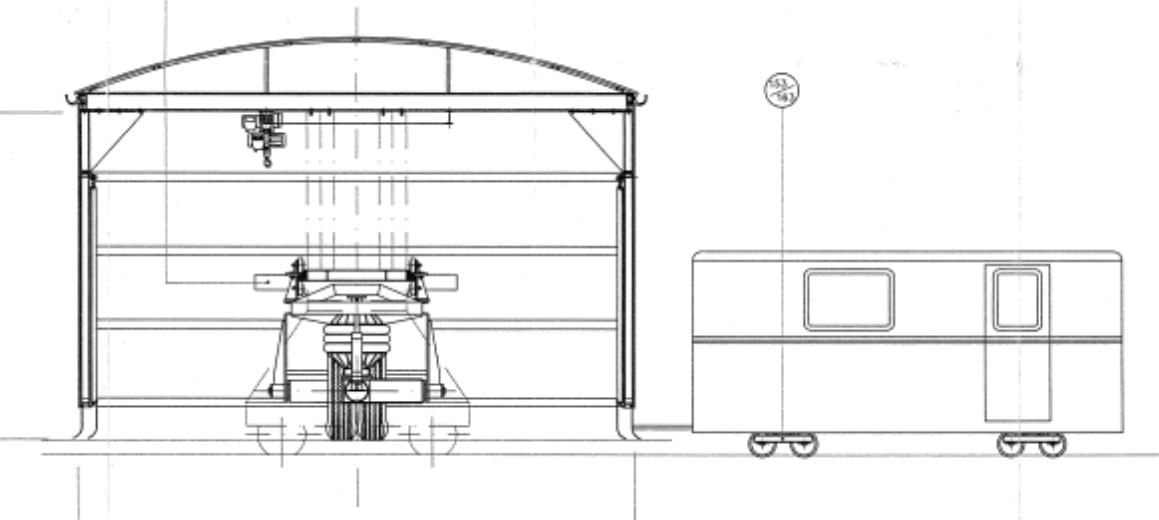
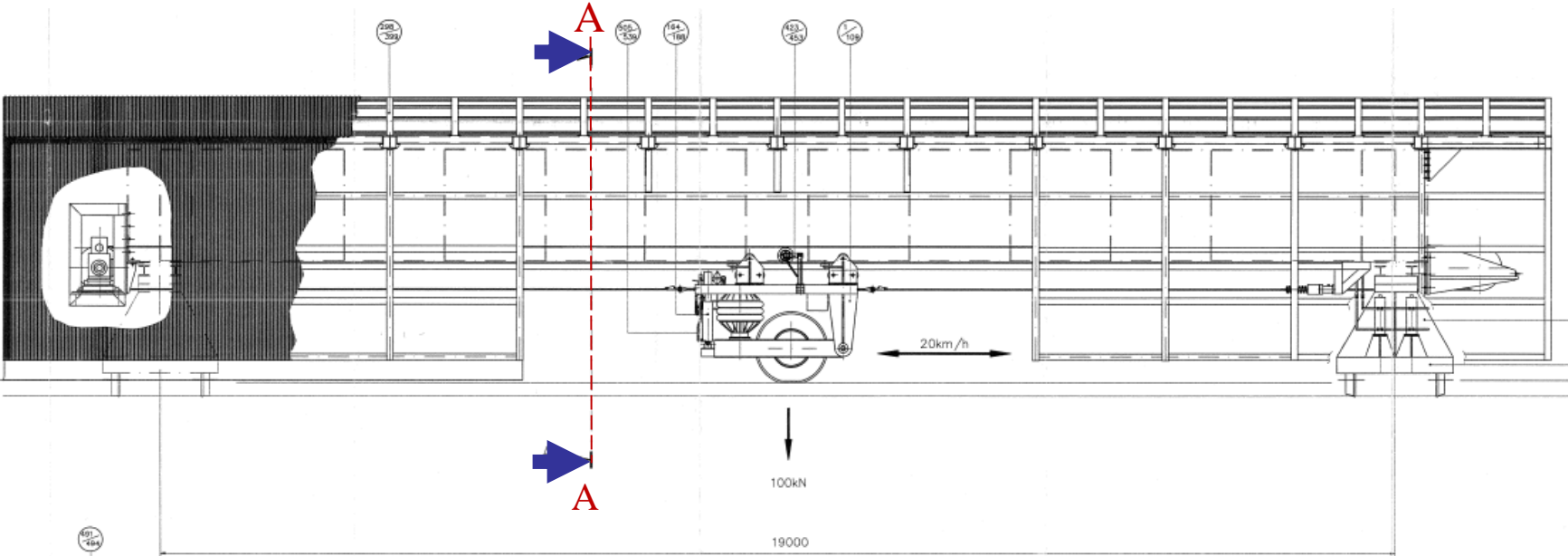

Section A - A

LINTRACK test facility

Max Speed 20 km/h

Enclosed chamber with heating facility up to 80°C

Equipped with Computerised control

Different Tires can be mounted

Possibility of wheel wandering

Max Load 100 kN

Whole facility movable on railway tracks



Ongoing LINTRACK testing program

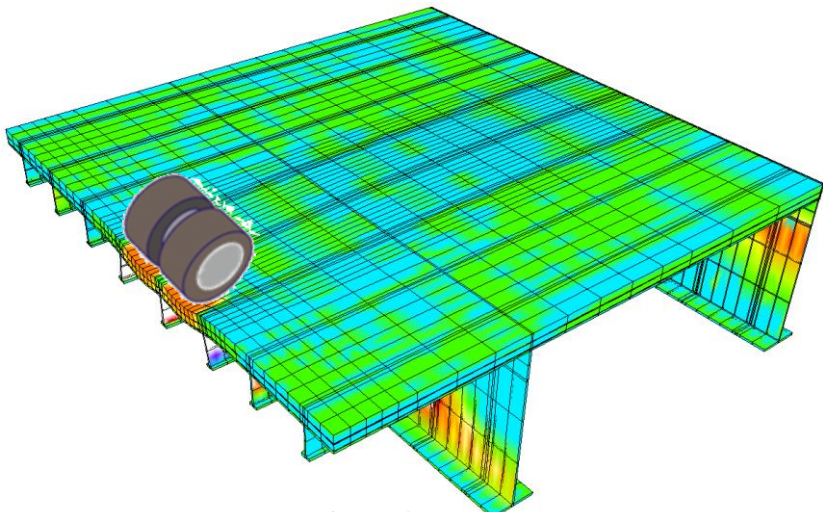

Steel Deck Bridges

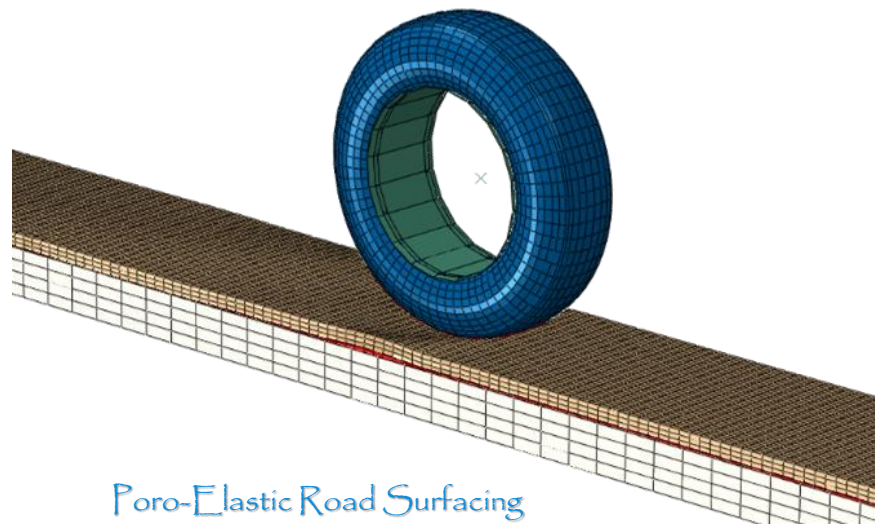

Poro-Elastic Road Surfacing

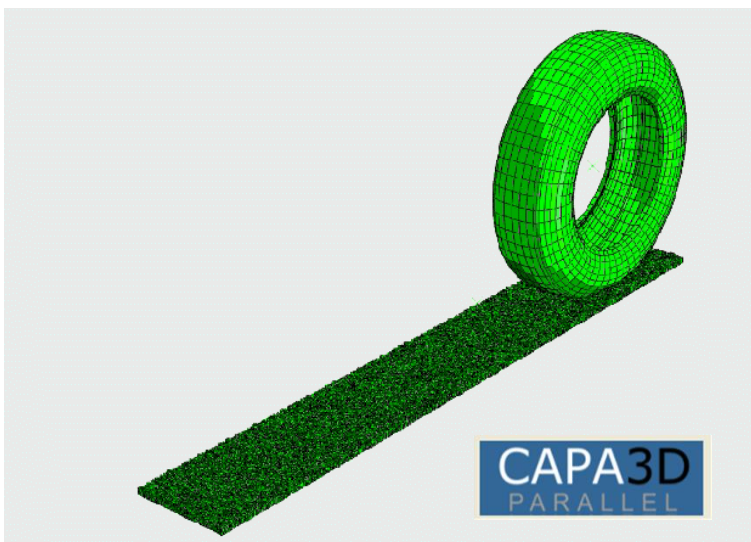

SKID & Rolling resistance

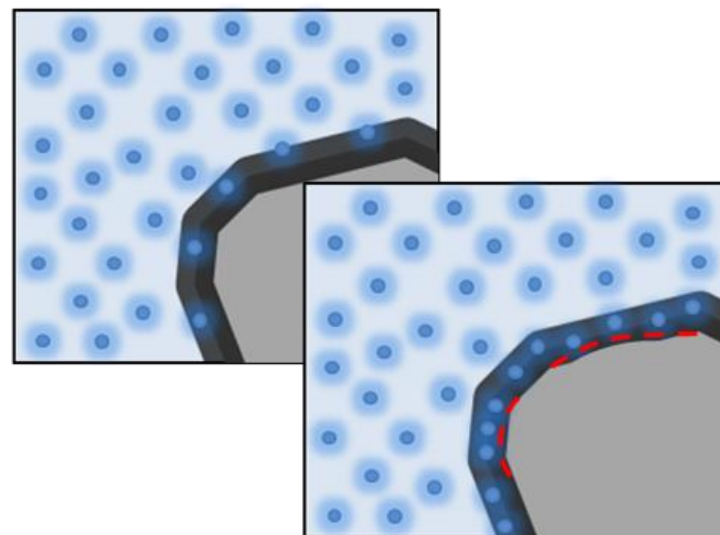

Aging

Asphalt Surfacing on Steel Deck Bridges



Asphalt Surfacing on Steel Deck Bridges

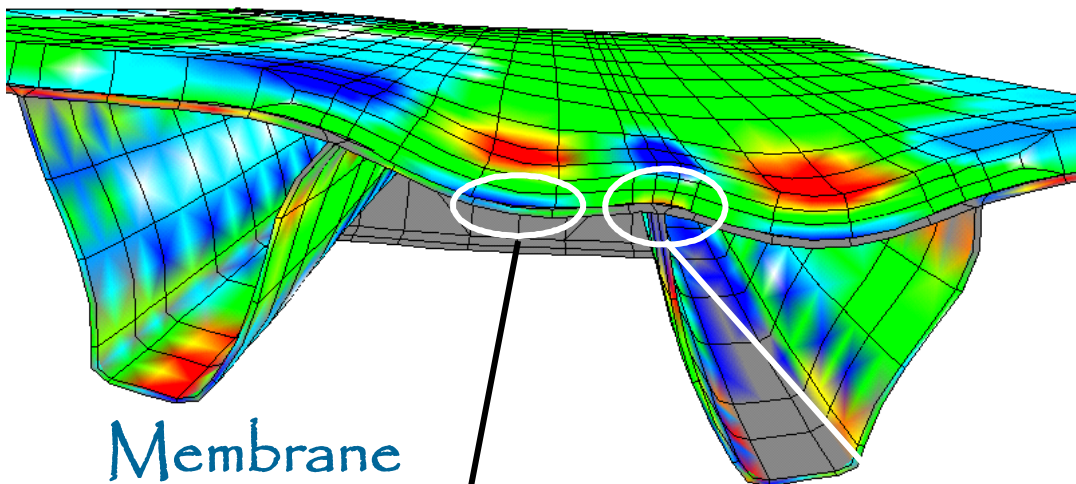

Membrane adhesive failures

