



High Voltage Technologies Matchmaking Event

24th April 2024



Materials
&
Components

Diagnostics
&
Monitoring

Testing &
Dimensioning

Asset
Management



CONTENTS

Materials & Components

Effects of harmonics on flued insulation in MV cable joints.....	1
COMPACT NEW TYPE MASS SPECTROMETER HIGH VOLTAGE CONNECTION SYSTEM	3
EPOXY RECEPTACLES FOR DEEP VACUUM HVDC X-RAY APPLICATIONS.....	4
Design and prototyping of a dc source array based on wireless power transfer technology for high voltage cascaded H-bridge	5
Design and optimization of a high voltage pulse transformer for studying Insulation aging under pulse stress.....	6
TUNED HVDC MATERIAL FOR HIGH DEMANDING CT CONNECTION SYSTEMS	7
Breakdown strength of insulation materials.....	8
UNderstanding and classifying insulation failures	9
3-D Macroscopic simulation of streamer development in mineral oil	10
Power electric distribution analysis in future electric aircrafts	11
Retrofitting the 72,5 kV L-SEP GIS to replace SF6 with Clean Air: THE GIS.....	12
Retrofitting the 72,5 kV L-SEP GIS to replace SF6 with Clean Air: The GRID	Error!
not defined.	Bookmark
Design a HVDC MW-level MMC converter for electrolyzers	13
DEVELOPMENT OF OVER-VOLTAGE AND OVER-CURRENT PROTECTION OF SERIES CONNECTED SiC MOSFETS HIGH VOLTAGE SWITCH	14
DEVELOPMENT of half-bridge MMC submodule using high voltage switch for universal high voltage arbitrary waveform generator (AWG).....	15

Diagnostics & Monitoring

Partial discharge of ionic wind effect under repetitive negative half-sine voltage excitation	16
AGING OF PRINTED CIRCUITBOARDS AND HIGH VOLTAGE POWER CONVERTERS IN FUTURE ELECTRIC AIRCRAFTS	17
SOLID-STATE HIGH VOLTAGE DC CIRCUIT BREAKER FOR ELECTRIC AIRCRAFT APPLICATIONS	18
HIGH POWER DENSITY MEDIUM FERQUENCY TRANSFOEMR FOR MV DC-DC CONVERTERS OF FUTURE ELECTRIC AIRCRAFTS.....	19
HVDC cable joints monitoring and routine test review	20
selective tiger mosquito HV killer trap.....	21

Testing & Dimensioning

Feasibility DC-field measurement technique.....	22
---	----

Substation insulation coordination for positive lightning.....	23
IMPLEMENTATION OF MODULAR MULTILEVEL CONVERTER CONTROL ALGORITHMS TO GENERATE ARBITRARY COMPLEX WAVESHAPES FOR HV TESTING	24
An Innovative calibration method WITH pcbS for pea space charge measurement.....	25
Coupling effects between DC and AC circuits on overhead lines:	25
Square wave pulser for measuring earth electrodes.	27
High-Frequency Analysis of Earth Electrode Impedance:.....	28
Natural arc extinction in air.....	29
Breakdown in HVDC GIS.....	30
Technical requirements for HVDC GIS	31
Winding loss Estimation in magnetic components with Litz wire	32
design of a HV amplifier with maximum slew rate and BANDWIDTH possible	33
Construction of a high voltage diode for Transient Overvoltage Testing of HVDC Extruded Cable Systems with Extreme Time Constants	34
Case study on high voltage cable testing on offshore assets	35
High VOLTage demonstrations toolbox for general public	36
Feasibility fAST HYBRID MV circuit breaker for PV Farm integratiON	37
Proof-of-Principle for solar storm compliance test installation.....	38
generating 100-250 times nominal current pulses for LPIT testing.....	39
Design and Simulation of high-power windings for medium-frequency transformers (mft)..	40
Design and implementation of a 12.5 kW three-phase inverter	41
High Frequency accelerated aging of insulation material FR-4 for medium voltage PCB planar transformer	42
Asset Management	
To research if a failure on existing GIS 380 Kv can be predicted by pd-measurement.....	43
LIFE EXTENSION (GAS INSULATED) SWITCHGEAR.....	44

TUNING 110 KV VOLTAGE TRANSFORMER FOR PQ-MEASUREMENT

Type of project: MSc thesis

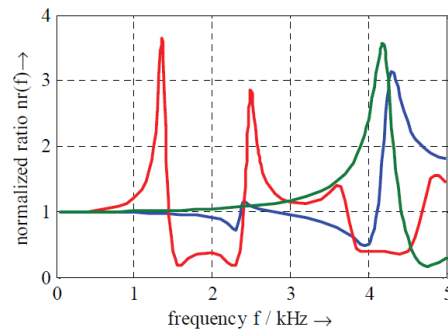

Normalized transformer ratio $nr(f)$ for 66-kV-VT (green), 110-kV-combined transformer (blue) and 220-kV-VT (red)

Tuning 110 kV voltage transformer for PQ-measurement
Scope:

Improve the frequency behaviour of 110 / 150 kV transformers such that they can be used for measurement of harmonics in the electricity grid.

Problem definition:

Conventional high-voltage voltage transformers (HV VTs) are not suited for the measurement of harmonics in the electricity grid (up to 25th harmonic) due to internal resonances (see as an example picture above). The question is to what extent this non-ideal wideband behaviour of HV VTs can be compensated for by connecting a special burden to the output of the VT.

Method:

- Literature study on the limitations of wideband voltage measurements using conventional HV VTs
- Evaluation of existing solutions to (partially) compensate for non-ideal HV VT behaviour
- Develop a wideband model for 110/ 150 kV VTs, and based on this model design a special burden that can be connected to the output of the VT to improve its wideband behaviour.
- Test the simulation on a real VT with a to be adapted burden with an arbitrary wave shape generator, developed at TU Delft.

The work will be performed in close collaboration with TenneT, the Transmission System Operator of the Netherlands.

Research objectives:

Feasibility report that describes to what extent non-ideal frequency behaviour of 110 / 150 kV VTs can be improved by a specially-designed burden connected to its output.

Courses and supervision:

No specific courses are needed as background for this thesis project. Good affinity with electrical circuit modelling is very beneficial for doing this assignment. The modelling can be done at the University of Twente, however the tests shall be performed at Technical University of Delft.

Contact: Part of project is in cooperation with TenneT

Prof. Gert Rietveld g.rietveld@utwente.nl,

Dr. Tom Hartman tom.hartman@utwente.nl

Ir André Lathouwers, a.g.a.lathouwers@tudelft.nl,

Dr. Ir. Dennis van der Born, d.vanderBorn-2@tudelft.nl



EFFECTS OF HARMONICS ON FLUED INSULATION IN MV CABLE JOINTS

Type of project: MSc thesis / Extra Project

**Scope:**

Theoretical and practical analysis on the effects of harmonics on insulation materials in medium voltage joints. A comparison between solid and liquid insulation materials.

Problem definition:

In recent years, the architecture of the power system has been the subject of a major change. The commonly known structure with centralized generation and one directional power flow, gives gradually the place to the new concept of the power network where both the energy generators and consumers are distributed. Particularly, the continuously increasing environmental concerns as well as the legal regulations result in a widespread installation of renewables. In addition, storage devices are incorporated in the network in order to cope with sudden increase of the generated energy. To facilitate the energy flow from the renewables towards the power network, the proper voltage level is maintained by means of transmission controllers. Such controllers consist of high frequency switching elements and the operation of such devices introduces high frequency harmonics that are propagated in the vicinity of the installed controller. On the one hand, a high content of harmonics is an emerging issue for the power network. On the other hand, some researches show the deleterious effect of high frequency signals on the reliability of electrical insulation.

In this research we want to investigate what the effects of harmonics are on liquid insulation and whether this differs from solid insulation media in medium voltage cable joints.

Methodology:

A theoretical desk study including simulation models.

Followed by validation in a laboratory.

Research Objectives:

- An inventory of the effects of harmonics on insulation materials.
- A comparison between solid and liquid insulation materials.
- Practical proof of the effects.

Contact details:

- Company supervisors: Ir. Hassan Azhar and Ir. Dennis Bergsma, < h.azhar@lovink.com >
- TUD Supervisor: Dr. Ir. Mohamad Ghaffarian Niasar, < M.GhaffarianNiasar@tudelft.nl >



COMPACT NEW TYPE MASS SPECTROMETER HIGH VOLTAGE CONNECTION SYSTEM

Type of project: <MSc thesis>

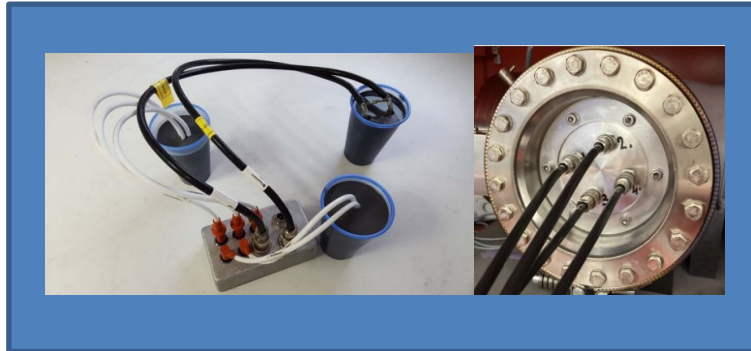

Scope:

Concept for the most compact low noise 30kV (..kHz PWM) high voltage connection system for Mass Spectrometers.

Problem definition:

Today, standard 20kVDC (BNC-type) high voltage connection systems are used for Mass Spectrometers. Spectrometers are however not used at DC but at Pulsed high voltage (up to various kHz). Current BNC-type connectors are easy to install but not free from Partial Discharge, leading to EMI-noise and reduced kV-stand-off. The spectrometer-market is growing and there is a tendency towards higher kV, higher frequency, low noise, high kV-stability and reliability without loss of compactness. The current DC-connectors are a limitation for that growing market.

Methodology:

Market survey on available existing connection systems for e.g. Mass Spectrometers, setting requirements for the “ideal” connection system up to 30kV. Working out the ideal high voltage connection principles, run simulations, building proof of principle to confirm the feasibility.

Research Objectives:

- Electrical simulations on Mass Spectrometer connection systems
- Research and development on feasible 30kV connection designs
- High voltage insulation methodology study
- Design of experiment on HV connection systems
- Electrical-mechanical tests on proof of principle

Contact details:

- Company Supervisor: Edo Hermsen, < edo.hermsen@vareximaging.com >
- TUD supervisor: Mohamad Ghaffarian Niasar, < m.ghaffarianniasar@tudelft.nl >

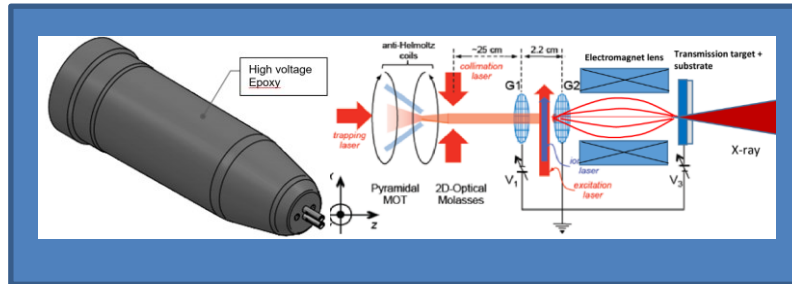

EPOXY RECEPTACLES FOR DEEP VACUUM HVDC X-RAY APPLICATIONS
Type of project: <MSc thesis>

Scope:

Investigate the possibility to design a reliable 300kVDC epoxy-receptacle for “open” micro-/nano focus X-ray tubes systems, with reliable high voltage and vacuum performance.

Problem definition:

Current HVDC receptacles for micro-/nano focus X-ray systems are mostly made of epoxy insulation against ceramic. The epoxy material is relatively cheap and in general works well for microfocus systems. Sometimes epoxy receptacles cause batch-wise uncontrolled HV-instability, leading to low production yield. Unknown is the background for this instability; degassing of epoxy material, fluctuation raw material, unreliable vacuum seals, surface impurity, not fully cured epoxy material, etc. It's desired to understand the phenomenon of instability in combination with microfocus systems and how to optimize. Ideas could be changing epoxy curing process, using surface coatings to seal vacuum side, changing the high voltage conditioning process or changing epoxy compound material.

Methodology:

Literature study on phenomenon vacuum high voltage instability of epoxy insulators. Determine proof of principle setup to verify the performance differences between various epoxy materials under deep vacuum i.e. high voltage. Build a functional prototype with best proposed materials/process/design. Set requirements to come to the ideal receptacle interface for microfocus systems.

Research Objectives:

- Electrical field simulations on micro-focus systems.
- Investigation into causes of high voltage instability in deep vacuum systems.
- Research on alternative epoxy materials in relation to available production processes.
- Investigation how to improve kV stability and conditioning process.
- Verification of improvements by proof of concepts.

Contact details:

- Company Supervisor: Edo Hermsen, < edo.hermsen@vareximaging.com >
- TUD supervisor: Mohamad Ghaffarian Niasar, < m.ghaffarianniasar@tudelft.nl >



DESIGN AND PROTOTYPING OF A DC SOURCE ARRAY BASED ON WIRELESS POWER TRANSFER TECHNOLOGY FOR HIGH VOLTAGE CASCADED H-BRIDGE

Type of project: <MSc thesis>

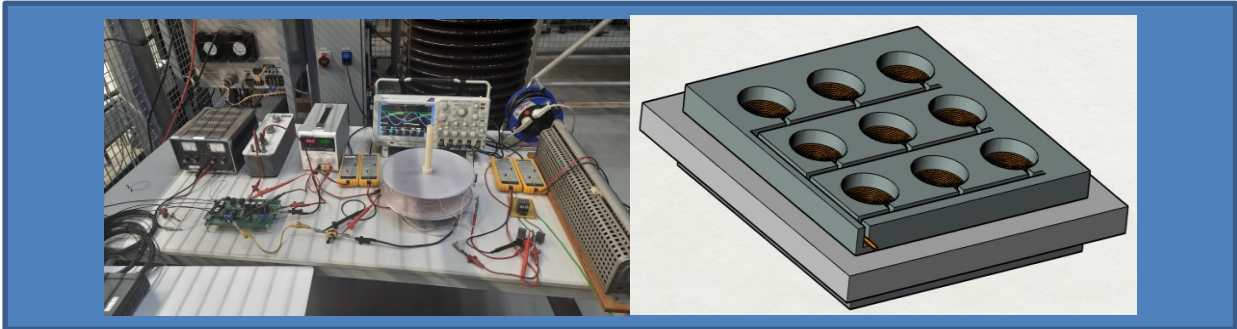
**Scope:**

The goal of this project is to design and prototype an array of DC sources with high voltage isolation based on wireless power transfer, to be used in high voltage cascaded H-bridge arbitrary waveform generator.

Problem definition:

High frequency pulses and harmonics are the type of stress that are being added to the grid following the increase penetration of power electronics. To ensure reliability of power component it is necessary to test them under actual stress present in the grid. It is therefore requested by number of testing companies, to design and prototype a high voltage arbitrary voltage waveform test generator. The goal of the project is to design a power electronics based HV test generator capable of generating 33 kV arbitrary voltage waveform. A candidate topology for such test generator is cascaded H-bridge topology. Isolated power supply is required in cascaded H-bridge topology with insulation clearance sufficient for the operating voltage of the test generator. Using ferrite core/iron core transformers at 33 kV insulation level requires a complicated insulation system which ends up into a bulky structure. In this regard, a novel idea of using wireless power transfer with high voltage insulation clearances is being proposed for this master thesis. The goal is to use existing knowledge in wireless power transfer, in combination with high voltage consideration required for this project, and come up with the most suitable design.

Methodology:

A relevant previously completed master thesis at HV laboratory must be reviewed first. The best transfer ratio that results in the most compact design, with suitable insulation clearances must be chosen. At least three cells should be built and tested. Mutual interaction between the cells, and insulation performance of the array must be analysed with experiments.

Research Objectives:

- Literature review of existing topologies for wireless power transfer.
- Design and construction of the power array based on HV requirements and desired power transfer capability. Suitable dielectric and cooling system must be chosen.
- Experimental verification of the concept design with at least two cells

Contact details:

- Supervisor: Mohamad Ghaffarian Niasar, <m.ghaffarianniasar@tudelft.nl>



DESIGN AND OPTIMIZATION OF A HIGH VOLTAGE PULSE TRANSFORMER FOR STUDING INSULATION AGING UNDER PULSE STRESS

Type of project: <MSc thesis >

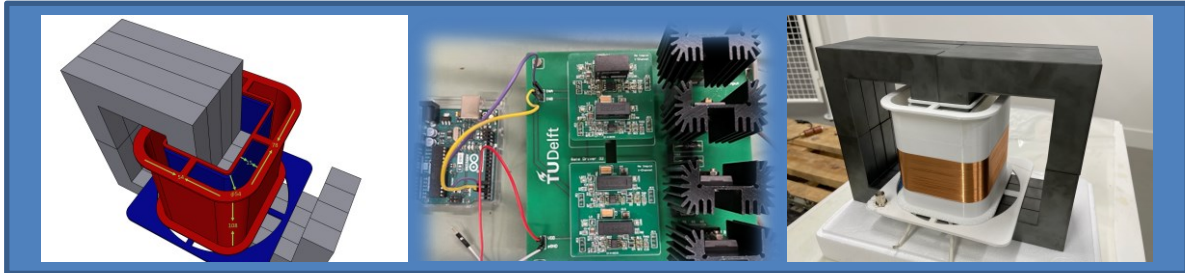
**Scope:**

To design, optimize and prototype a 20 kV high voltage pulse transformer. The transformer will be then used to test insulation aging test under high voltage variable frequency pulse stress.

Problem definition:

Due to high frequency and fast switching of the SiC MOSFETs, a very high dv/dt is created which accelerates insulation ageing thereby reducing the average lifetime of components connected to such type of SiC MOSFETs. To understand aging mechanism of insulation under high voltage pulse stress we need to have a reliable test source that can produce such HV pulse stress at high frequency.

Methodology:

The student must first read two master theses which were carried out on this topic at HV laboratory of TU Delft. Important parameters that impact design of a pulse transformer must be identified first. An optimization programme should be written (using MATLAB GA or similar algorithms) to optimize the design of the pulse transformer considering high voltage and output pulse shape constrains. An H-bridge will be used to drive the transformer and at the end insulation aging test will be carried out on oil-impregnated paper (OIP) samples.

Research Objectives:

- Literature review and Identifying important design parameters of a pulse transformer.
- Writing an optimization programme to optimize design of a HV pulse transformer.
- Prototype the transformer and modulator and perform insulation aging tests on OIP samples.

Contact details:

- Supervisor: Mohamad Ghaffarian Niasar, <m.GhaffarianNiasar@tudelft.nl>



TUNED HVDC MATERIAL FOR HIGH DEMANDING CT CONNECTION SYSTEMS

Type of project: <MSc thesis>

**Scope:**

Investigation to formulate dedicated rubber compound materials in combination with ceramic HVDC X-ray tube system.

Problem definition:

Manufacturers of high voltage components are often not able to adapt the electrical-mechanical properties of raw materials as they don't know how to achieve that. Standard rubber-connector material and standard ceramic-receptacle materials are often taken for high demanding X-ray system applications without knowing if they are the perfect match. This leads to reliability issues in the field, like reduced lifetime, X-ray tube punctures, connector and receptacle blow-out. As X-ray tubes run very warm, balanced electrical-mechanical properties of the chosen high voltage materials are important along the whole temperature range, to minimize trapped charges, loss of mechanical compression and uncontrolled field-enhancement. Also tube instability (arcing) has to be considered in this investigation as potential risk phenomenon.

Methodology:

Determine the requirements for the most ideal material combinations. To formulate the ideal rubber compound, run tests on sample size to confirm electrical-mechanical properties. Create a proof of principle to verify the results by type testing.

Research Objectives:

- In-depth simulations of X-ray connection systems
- Understanding of electro-mechanical behaviour of X-ray tube connection systems
- Research on feasibility to tune rubber compound materials
- Building and testing proof of principle with tuned material

Contact details:

- Company Supervisor: Edo Hermsen, < edo.hermsen@vareximaging.com >
- TUD supervisor: Mohamad Ghaffarian Niasar, < m.ghaffarianniasar@tudelft.nl >



BREAKDOWN STRENGTH OF INSULATION MATERIALS

Type of project: MSc thesis

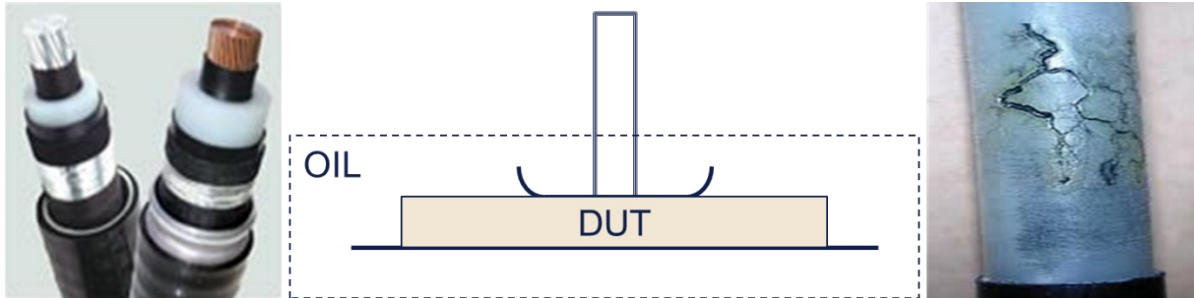

Scope:

Find the relation of breakdown strength of cable insulation materials like XLPE / Silicon rubber, depending on voltage, temperature and frequencies (and its interdependency) ranging from DC to 50 kHz or more.

Problem definition:

Due to the energy transition the power grid is subjected to increased stresses, threatening the lifetime of our electricity grid components and the reliability of our electricity supply. Our grid was designed for systems running on power frequency (50 or 60 Hz) with slowly changing load. However, more and more solar and wind power generation is connected to the grid, with highly varying power production and the consumption of electricity is increasing with high load variation. Both aspects result in frequent and vast load swings, giving steep temperature rises in the grid components facilitating the electric energy transportation. Both in production and in consumption the use of power electronics is expanding exponentially giving additional harmonic losses in the system of considerable higher amplitudes and frequencies than considered during the design of the system.

The effect of these changes is to be studied to prevent the industry is caught by surprise of frequent failures of our reliable grid components.

Methodology:

This work involves substantial experimental work to collect data and identify correlations between the different test parameters, like voltage, frequency and temperature. Small reproductive samples of the insulation materials need to be made, after which they are subjected to a semi homogeneous electric field until electric breakdown, tested under a range of frequencies.

Research Objectives:

- Literature review of solid insulation breakdown mechanisms
- Design and preparation of experimental setup, performing breakdown tests under different conditions
- Identify correlations between breakdown voltage and time and the different test parameters like voltage, frequency and temperature

Contact details: Part of PhD project in cooperation with DNV

- (DNV) ir. Mischa Vermeer HBK, < m.e.vermeer@tudelft.nl >
- Dr. Ir. Mohamad Ghaffarian Niasar < M.GhaffarianNiasar@tudelft.nl >



UNDERSTANDING AND CLASSIFYING INSULATION FAILURES

Type of project: Extra Project at DNV (Internship)

**Scope:**

Identify trends and potential correlation in failures of insulation materials, like Paper / oil / XLPE / Silicon rubber etc.

Problem definition:

The electricity grid, including all equipment that is connected to it is a very reliable system and often referred to the largest machine built by mankind. However, a every technical system, it is prone to failure. DNV performs as independent failure investigator many root cause analysis on system and equipment failures. These analyses are typically classified and reported individually. Therefore, a birds eye perspective and trend analysis are challenging.

We are interested if, due to the energy transition e.g. more rapidly changing load swings and more influences by power electronics, the system is higher stressed than before the energy transition with potentially an increase in failure behaviour and/or types of failures. Classification of types of failures and damage patterns based on the type of load, location, voltage or thermal stress and trend developments are relevant to identify, so the industry can be better prepared for further changes in the market.

Methodology:

This work involves a literature search on available knowledge on failure classifications and trends, including analysis of historical failures and failure causes. It also involves in-depth interactions with the industry partners, e.g. utilities, manufacturers and users large industry to collect and analyse failure data.

You work together with many experts within DNV, learning many things on power equipment and the electricity grid, it's reliability and failure causes.

Research Objectives:

- Literature review of failure behaviour and trends
- Analysis of root cause reports and understanding the classification of failures
- Conference paper on the development of failures in the electricity power system

Contact details: Part of PhD project in cooperation with DNV

- (DNV) ir. Mischa Vermeer HBK, < m.e.vermeer@tudelft.nl >
- Dr. Ir. Mohamad Ghaffarian Niasar < M.GhaffarianNiasar@tudelft.nl >

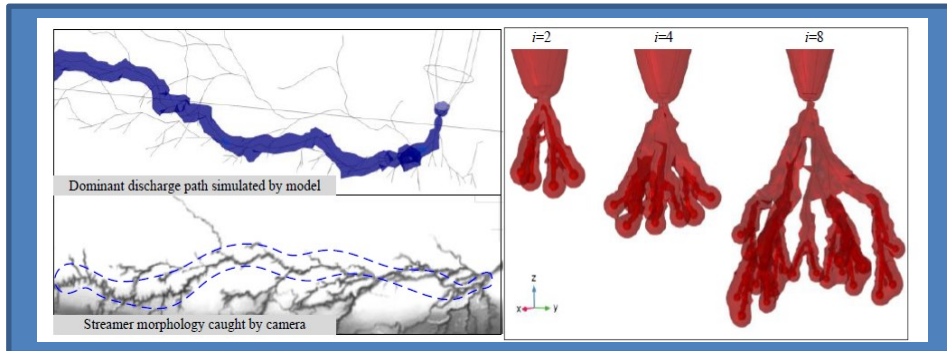

3-D MACROSCOPIC SIMULATION OF STREAMER DEVELOPMENT IN MINERAL OIL
Type of project: MSc thesis

Scope:

To quantify the key physical criteria values of the discharge in mineral oil and clarify the influence of different streamer parameters on the streamer propagation in mineral oil.

Problem definition:

The discharge characteristics of mineral oil play an important role in the insulation design and the withstand voltage test of transformers. A better understanding of the discharge mechanism of mineral oil will help optimize the insulation design. It is believed that the streamer propagation process is accompanied by branching, and a phase change is usually involved when making the streamer channel in liquids. Unfortunately, although there are already clear images captured with high-speed photography to prove the existence of the individual branches, the understanding and accurate prediction of streamer branches' behaviour in mineral oil are still insufficient. This thesis aims to enhance the knowledge in the field of streamer discharge in mineral oil, and to optimize the 3-dimensional macroscopic simulation to simulate the propagation of the streamer discharge taking into account the streamer branching process.

Methodology:

The simulation is performed by using COMSOL to determine the electric field distribution. Understand the basic physics of the discharge in oil firstly and learn how to use the existing proposed model. JAVA programming in COMSOL is required to make optimization.

Research Objectives:

- Literature review of the discharge simulation in insulation liquid.
- Study the effect of different streamer parameters (e.g. branching angle, branching numbers, streamer length, streamer head) on the streamer propagation.
- Establish mathematical formulas between these parameters and physical parameters (e.g. electrical field, potential).

Contact details:

- Postdoc researcher : Ruochen Guo, < R.Guo-3@tudelft.nl >

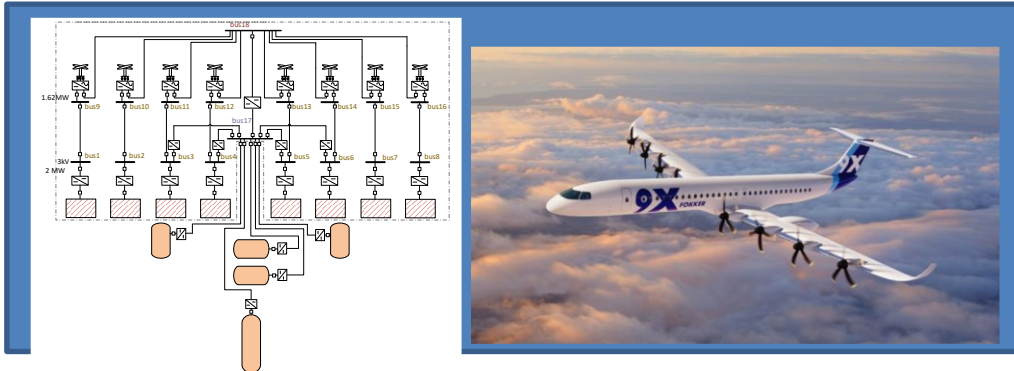

POWER ELECTRIC DISTRIBUTION ANALYSIS IN FUTURE ELECTRIC AIRCRAFTS
Type of project: <MSc thesis>

Scope:

The goal of this work is to perform the power flow analysis of the proposed power system of the electric aircraft under different contingencies. The effect of the voltage level definition of the basic bus bar and the power level selection of different power components will be considered.

Problem definition:

Even though achieving carbon-free and reduced CO₂ emission transportation is a prevailing goal, the aviation industry is in its infancy to arrive at passenger class all-electric aircraft (AEA) properly operating over commercial missions. Challenges are mainly associated with the components and their connections of the aircraft electric power system (EPS). When designing a reasonable electric architecture in the electric aircraft, initial assumptions of voltage level and power components sizing are required. However, the energy distribution of the power system is dynamic and the different flying processes (e.g. taking off, cruising...) cause difference power distributions. And some emergency situations must be considered to ensure the safety of the mission. These potential changes cause a possible oversizing or underestimation of the initial EPS design. Therefore, it is necessary to implement power electric distribution analysis under different operating conditions to check if the initially designed architecture, voltage level, and power components can stand the change of the flight and different contingencies.

Methodology:

Build the power flow model base on different proposed electric architectures by Simulink.

Research Objectives:

- Literature review about the electric power system design of future electric aircrafts.
- Power flow calculation and analysis of the proposed electric architectures with different voltage levels and power levels.
- Evaluating the results under different contingencies.

Contact details:

- Postdoc researcher: Ruochen Guo, < R.Guo-3@tudelft.nl >
- Supervisor: Mohamad Ghaffarian Niasar, < M.GhaffarianNiasar@tudelft.nl >
- Supervisor: Jianning Dong, < J.Dong-4@tudelft.nl >

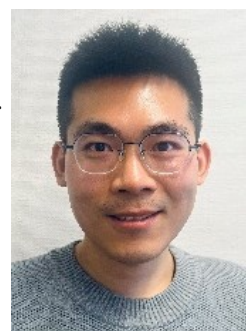

Type of project: MSc thesis

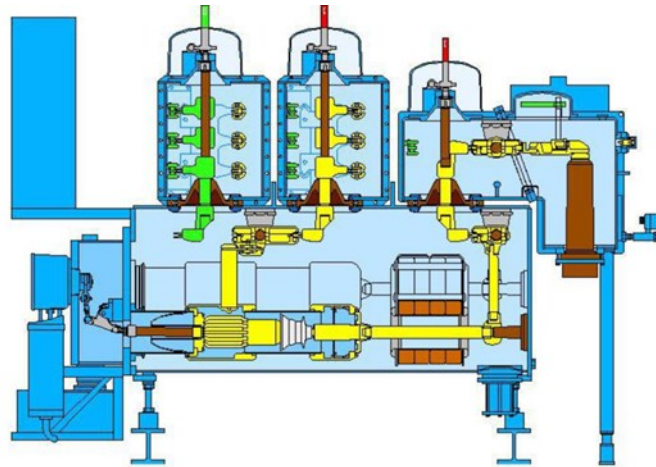

Scope: Verify by calculations of the electric fields and by testing in ESP-lab, as a function of the minimum allowable pressure for Clean Air filled (replacing SF₆ filled) L-SEP GIS with rating 72.5 kV can be used in the 50 kV grids. And advise from these calculations and tests which adaptations shall be made in its design to improve the withstand voltage at the potential weak spots further.

Problem definition: The L-SEP 72,5 kV, is a GIS which has been developed by the former Dutch company Holec, now part of Siemens Energy. In the Netherlands the DNOs (distribution network operators, such as Stedin, Alliander, Enexis) have installed many substations with this compact GIS in their so called 50 kV network, although fully type tested for 72,5 kV rated voltage. The first L-SEP switchgears have been installed in the early 1980's. Both for the insulation and the switching operations SF₆ is used. Meanwhile it is well known that SF₆ has a major issue, concerning the GWP (global warming potential) being 23500 times higher than CO₂. Therefore DNOs and TNOs want to reduce the amount of banked SF₆. Within the Netherlands now a research is to be initiated to verify if it would be possible to (partly) replace the SF₆ by technical air (Clean Air as it is called by Siemens) as insulation for the already installed L-SEP in the Dutch 50 kV grid (so at a lower rating as it was designed for).

Methodology:

To locate those internal spots that may get a critical field strength, by calculation of the electric field strength and by actual testing in the ESP-lab. to advise which (small) adaptations should be required.

Research Objectives:

- Locate by field calculations and testing the weak spots for GIS filled with Clean Air based on reduced rating of 50 kV and based on Clean Air.

Contact details:

- Ir. André Lathouwers a.g.a.lathouwers@tudelft.nl
- Dr. Ir. Mohamad Ghaffarian Niasar M.GhaffarianNiasar@tudelft.nl

Part of project is in cooperation with Siemens Energy and Stedin





DESIGN A HVDC MW-LEVEL MMC CONVERTER FOR ELECTROLYSERS

Type of project: <MSc thesis>

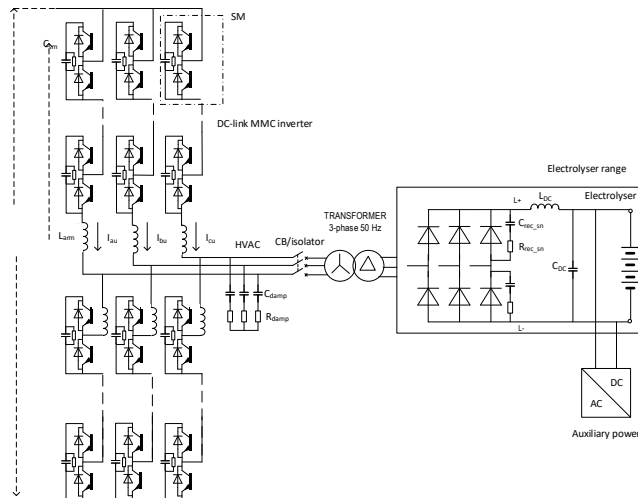

Scope: To study and design the upscaling of a MMC power converter for high-voltage DC-connection instead of medium-voltage DC-connection. The designed power converter will be used to power a low-voltage high-current electrolyser.

Problem definition: Vonk is leading manufacturer and system integrator of the power converters. Vonk along with other industrial partners is investing in upscaling of the *green hydrogen generation* in which the available energy from solar or wind is converted to feed the electrolyser with the desired power quality. A MW-level, state-of-the-art MMC based converter topology is proposed (and designed) by Vonk as an interface between a MVDC grid and LVDC electrolyser. The student shall design a MW-level converter topology to connect a HVDC grid (e.g., 80 kV) to the LVDC (e.g., 600 V) electrolyser. The focus will be on the design principles for HVDC and the design criteria for e.g., a HVDC MMC sub-module, voltage and current measurements and which semiconductor can be used in such a sub-module.

Methodology: Literature study about HV converters, HV power switches, possible potential hazards. Enhance existing MATLAB/Simulink simulation to Design/Specify every component from the proposed topology: e.g., MMC sub-module, transformers, filters, various measurements, and their interfacing with Vonk control platform, etc. Implement and verify some design principles of for instance a voltage measurement, current measurement or MMC sub-module in a high voltage laboratory.

Research Objectives:

- Determine requirements for design of a HVDC converter for a MW-level electrolyser system
- Specifications of main components of a HVDC converter.
- Proof of concept for voltage and current measurement at high voltage.

Contact details:

- TUD supervisor: Mohamad Ghaffarian Niasar, M.GhaffarianNiasar@tudelft.nl
- Company Supervisor: Mahesh Itraj, mahesh.itraj@iivonk.com
- Company HR Business Partner: Annemieke Moes-Teeuwen
☎ 06 55 08 50 81, Dokter Klinkertweg 22a, 8025BS ZWOLLE



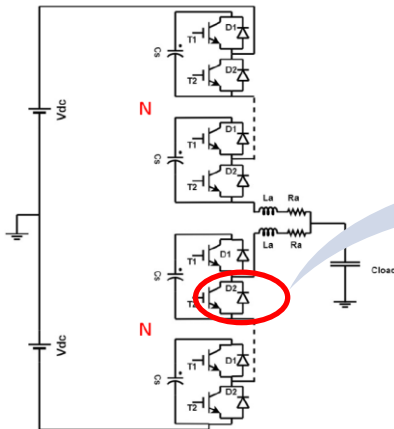

DEVELOPMENT OF OVER-VOLTAGE AND OVER-CURRENT PROTECTION OF SERIES CONNECTED SiC MOSFETS HIGH VOLTAGE SWITCH

Type of project: <MSc thesis>

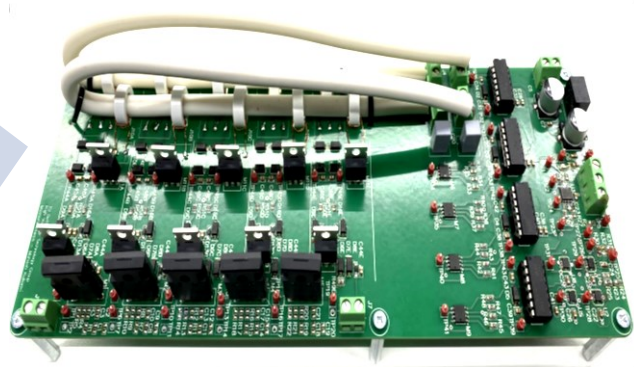

(a) Schematic of MMC based HV AWG



(b) High Voltage Switch Prototype PCB

Scope:

The goal is to understand the developed high voltage switch using series connected SiC MOSFETs, and develop an over-voltage and over-current protection mechanism.

Problem definition:

Modular Multi-Level Converters (MMC) have gained immense popularity in the backdrop of Energy Transition. TU Delft and KEMA laboratories are collaborating to create an MMC based universal High-Voltage testing device capable of generating High Voltage Arbitrary Waveforms. To achieve high voltage capability, the voltage blocking capability of individual switch and submodule need to be enhanced. An efficient and cost effective technique to do this is to put low voltage switches in series. However, when semiconductor switches are connected in series, the key challenge is to ensure equal voltage sharing for both static and dynamic switching states across the series-connected string. There is a significant correlation between the asynchronous gate driving signals and the voltage imbalance. Different types of intrinsic and extrinsic capacitive couplings also affect the voltage sharing. A high voltage switch has been developed using a scalable pulse transformer-based gate-driving technique for driving series-connected SiC MOSFETs. Detailed work on its development is available. This high-voltage switch is the basic building block with which a complete MMC will be developed. There is a need to develop an over-voltage and over-current protection mechanism for the series connected SiC MOSFETs high-voltage switch.

Methodology:

The main focus of the project is to develop a deeper understanding of the developed high voltage series connected MOSFETs switch and MMC topology and subsequently develop an over-voltage and over-current protection mechanism.

Research Objectives:

- Establish understanding of the developed high voltage switch with series connected SiC MOSFETs and embed protection mechanism in the high voltage switch PCB module for the MMC operation.

Contact details:

- PhD student: Sohrab Ghafoor, <s.ghafoor-1@tudelft.nl>
- Supervisor: Dr. Ir. M. Ghaffarian Niasar, <M.GhaffarianNiasar@tudelft.nl>



DEVELOPMENT OF HALF-BRIDGE MMC SUBMODULE USING HIGH VOLTAGE SWITCH FOR UNIVERSAL HIGH VOLTAGE ARBITRARY WAVEFORM GENERATOR (AWG)

Type of project: <MSc thesis>

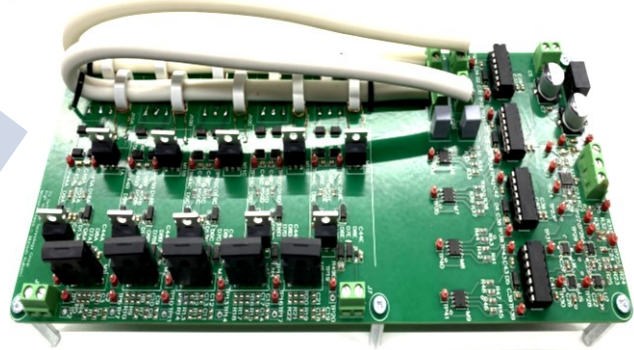
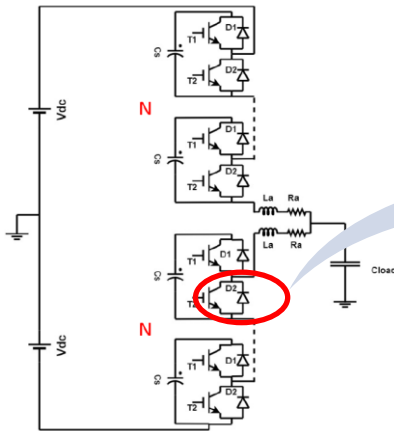

Scope:

The goal is to understand the developed high voltage switch using series connected SiC MOSFETs, make improvements and subsequently build a half bridge module PCB of an MMC AWG.

Problem definition:

Modular Multi-Level Converters (MMC) have gained immense popularity in the backdrop of Energy Transition. TU Delft and KEMA laboratories are collaborating to create an MMC based universal High-Voltage testing device capable of generating High Voltage Arbitrary Waveforms. To achieve high voltage capability, the voltage blocking capability of individual switch and submodule need to be enhanced. An efficient and cost effective technique to do this is to put low voltage switches in series. However, when semiconductor switches are connected in series, the key challenge is to ensure equal voltage sharing for both static and dynamic switching states across the series-connected string. There is a significant correlation between the asynchronous gate driving signals and the voltage imbalance. Different types of intrinsic and extrinsic capacitive couplings also affect the voltage sharing. A high voltage switch has been developed using a scalable pulse transformer-based gate-driving technique for driving series-connected SiC MOSFETs. Detailed work on its development is available. This high-voltage switch is the basic building block with which a complete MMC will be developed. There is a need to build a half-bridge submodule to be employed in MMC.

Methodology:

The main focus of the project is to develop a deeper understanding of developed high voltage series connected MOSFETs switch and MMC topology and their operation for the generation of complex arbitrary waveforms.

Research Objectives:

- Learn the basic working principles of MMC and its operation & control techniques to generate complex arbitrary waveforms
- Establish understanding of the developed high voltage switch with series connected SiC MOSFETs and build a high voltage half-bridge PCB module with it for the MMC operation

Contact details:

- PhD student: <Sohrab Ghafoor, s.ghafoor-1@tudelft.nl >
- Supervisor: < Dr. Ir. M. Ghaffarian Niasar, M.GhaffarianNiasar@tudelft.nl >

KEMA Labs

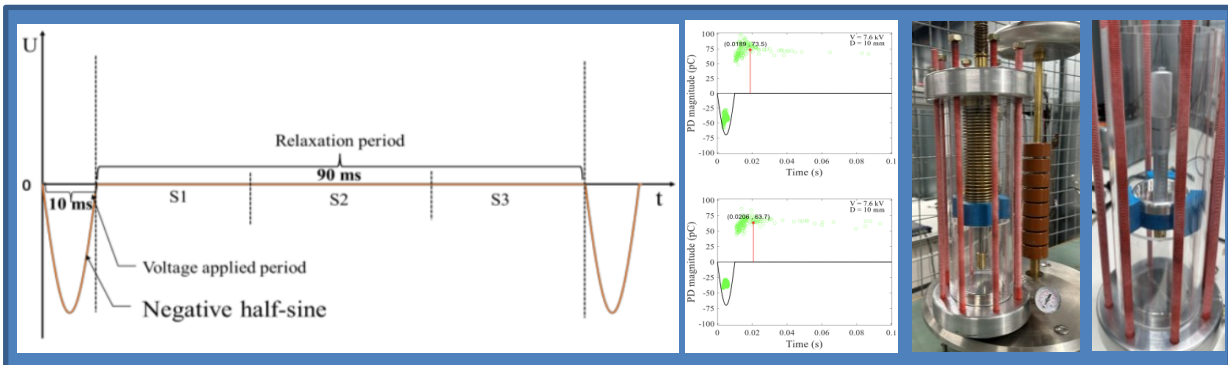

PARTIAL DISCHARGE OF IONIC WIND EFFECT UNDER REPETITIVE NEGATIVE HALF-SINE VOLTAGE EXCITATION
Type of project: MSc thesis

Scope:

To measure the partial discharge (PD) values under repetitive excitation of a negative half-sine voltage as shown in the second figure. To measure the phase-resolved PD (PRPD) patterns of various insulation materials under such excitation and to understand how the ionic wind effect PD patterns.

Problem definition:

The patterns of AC or DC partial discharges in general have been extensively studied within decades. However, the ion wind effect, which is shown in the first figure, for the partial discharge process is not common and has not attracted sufficient attention.

According to the references, under special repetitive excitation of a negative half-sine voltage, a back discharges will occur in the relaxation period between two sinusoidal waveforms. The prevalence of ion wind effect in partial discharges can be determined if proper quantitative analysis is performed.

In order to obtain sufficient partial discharge data for the verification of the theoretical ionic wind model, it is necessary to perform partial discharge experiments with the similar excitation for various insulation materials and to find their PRPD patterns. The expected result is shown in the third figure.

Methodology:

To measure PD of a needle-plate model for various insulation materials under repetitive excitation of a negative half-sine voltage. To verify their PRPD patterns with the theoretical ion wind model.

Research Objectives:

- To understand how the ionic wind effect works in PD process and why there is back discharge in the relaxation period of excitation.
- To measure PD of various insulation material under excitation in HV lab.
- To verify the theoretical ion wind model with the experiment result.

Contact details:

- PhD student: Zhifeng Guo, <Z.Guo-1@tudelft.nl>
- Supervisor: Mohamad Ghaffarian Niasar, <M.GhaffarianNiasar@tudelft.nl>



AGING OF PRINTED CIRCUITBOARDS AND HIGH VOLTAGE POWER CONVERTERS IN FUTURE ELECTRIC AIRCRAFTS

Type of project: MSc thesis/ Extra Project

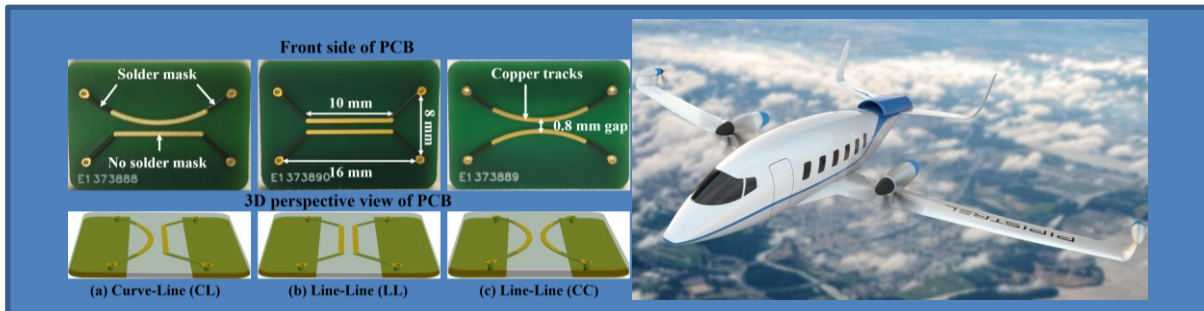

Scope:

The goal of this work is to evaluate aging of PCBs due to presence of partial discharges at different atmospheric conditions and under different electric stress.

Problem definition:

As the demand for eco-friendliness of aircraft increases, more/all-electric aircraft (MEA/AEA) has been widely investigated in recent years. For MEA/AEA, efficient electrical drives require a high-power density, which means that a large number of printed circuit boards (PCBs) are required to enable the operation of the electrical system in the avionics. Although the higher voltage amplitude and voltage frequency variation can help increase the power density, yet this also brings a greater threat to the electrical insulation of PCBs. Since the electrical equipment in the aircraft operates under high-frequency voltages, in a low-pressure environment, and compacting electronic circuitry is desired to reduce space and weight in aircraft, this makes the insulation performance much lower than that of conventional electrical equipment on land. Therefore, there is an urgent need to assess the insulation status of PCBs in aircraft, to avoid catastrophic failures. In addition, PCBs for aircraft need insulation testing for quality control before they are put into service, and therefore suitable and reliable test procedure must be developed and standardized.

Methodology:

The work involve substantial experimental work and data analysis using available statistical models

Research Objectives:

- Literature review about the on-board electrical system of future electric aircrafts.
- Design and preparation of the experimental setup, performing aging tests under different conditions.
- Evaluating the results using statistical methods, and writing final thesis.

Contact details:

- TUD Supervisor: Dr.ir. Mohamad Ghaffarian Niasar, M.GhaffarianNiasar@tudelft.nl



SOLID-STATE HIGH VOLTAGE DC CIRCUIT BREAKER FOR ELECTRIC AIRCRAFT APPLICATIONS

Type of project: Master thesis / Extra Project

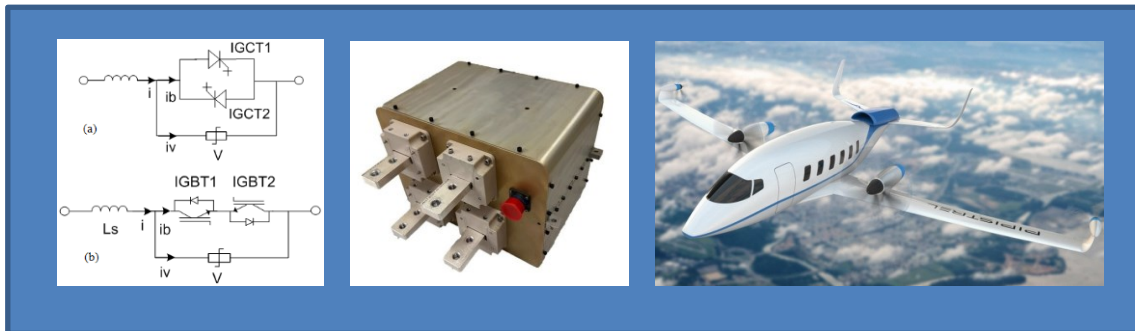

Scope:

To design, simulate and prototype a 3 kV, 600 A solid-state DC circuit breaker with ultra-high power to weight density.

Problem definition:

Future all electric aircraft have electric load in order of several MW per motor (several motors per wing). Requirement of extra high reliability in electric aircrafts and at the same time limitation in weight budget for electric system of the aircraft, demands a fast solid state protection system to be placed in between batteries and electric motors.

Methodology:

Perform a comprehensive literature study on solid state DC circuit breaker. Perform a comparison between the existing topologies based on their efficiency, weight, voltage and current levels, and reliability. Perform simulation of the most suitable topology, propose improvement in the design and prototype a downscale model of such MVDC Solid State circuit breaker (DC SSCB)

Research Objectives:

- Literature review and Identifying existing topologies for DC SSCB, and a comprehensive comparison between them.
- Performing simulation of the most promising topology and propose improvements.
- Prototype a down scale DC SSCB and demonstrate its functionality.

Contact details:

- TUD Supervisors: Dr.ir. Mohamad Ghaffarian Niasar & Dr. Ir. Jianning dong
 < M.GhaffarianNiasar@tudelft.nl >



HIGH POWER DENSITY MEDIUM FREQUENCY TRANSFORMER FOR MV DC-DC CONVERTERS OF FUTURE ELECTRIC AIRCRAFTS

Type of project: Master thesis / Extra Project

**Scope:**

To design, simulate and prototype a 3 kV/800 V, 1.8 MVA Medium Frequency transformer optimized for efficiency and weight

Problem definition:

Future all electric aircraft have electric load in order of several MW per motor (several motors per wing). Due to limitation of weight budget for the electric system of the aircraft, It is demanded to design MW level DC-DC converters with ultra-high power density and efficiency. The main source of weight in an isolated DC-DC converter is the MF transformer. The goal is to optimize the design of such transformer for weight and efficiency.

Methodology:

Performing literature review on medium frequency transformers and understanding important parameters that affect their design. Selection of core material, winding structure, frequency of operation, insulation system and methods to estimate the core and winding losses are of importance. An optimization algorithm must be developed to find the pareto front of best design for weight and efficacy .

Research Objectives:

- Literature review on MF transformers
- Creating a design routine and performing multi objective optimization of transformer design for weight and efficiency
- Prototype a down scaled MF transformer and demonstrate its functionality

Contact details:

- TUD Supervisors: Dr.ir. Mohamad Ghaffarian Niasar & Dr. Ir. Jianning dong
< M.GhaffarianNiasar@tudelft.nl >



HVDC CABLE JOINTS MONITORING AND ROUTINE TEST REVIEW**Type of project:** MSc thesis

HVDC joints NKT

Scope:

Review the DC routine test for HVDC cable joints and investigate a monitoring system

Problem definition:

Due to the large number of joints in land-based HVDC cables, one average one per kilometre, failures of joints plays a decisive role in overall system performance. The electric field in some regions within an HVDC joint during operation can be much higher than seen during routine testing since field distribution in such a joint is highly sensitive to temperature. The DC routine test according to IEC 62895 should be investigated and modifications recommended to better reflect operational conditions, in parallel a monitoring system can be proposed.

Methodology:

Perform a literature survey and come up with recommendations for DC routine tests on joints and a possible (on-line) monitoring system.

Research Objectives:

- Review literature, Cigré brochures and standards
- Consult staff of manufacturers, e.g. Prysmian/NKT and test laboratories, e.g. KEMA Labs
- Modelling
- Recommendations

Contact details:

- Prof. Ir. Peter Vaessen P.T.M.Vaessen@tudelft.nl; < Peter.Vaessen@kema.com >
- Dr. Ir. Mohamad Ghaffarian Niasar < M.GhaffarianNiasar@tudelft.nl >

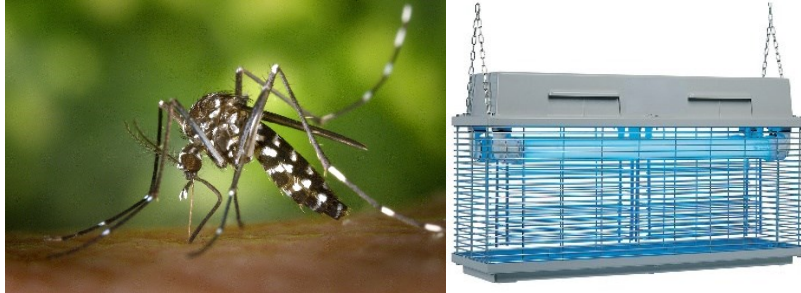

SELECTIVE TIGER MOSQUITO HV KILLER TRAP**Type of project:** Extra Project**Scope:**

Develop a selective tiger mosquito high-voltage killer trap for outdoor application.

Problem definition:

Due to climate change tiger mosquitos invade Europe from the south, it is an aggressive biter with a very painful sting and can transmit diseases like dengue and yellow fever. As they “approach” the Netherlands a selective (mosquitos only) high voltage killer trap that can secure a terrace location is sought of. Note state-of-the-art UV-lamp based insect traps (shown above) are NOT selective.

Methodology:

Investigate what attracts the tiger mosquito, its range of operation and build (perhaps test) a safe and environmentally friendly high voltage device that selectively lures and kills.

Objectives:

- Combine biology and high voltage science in a selective and insect-friendly solution
- Contribute to social responsibility of the HVT group and TU Delft
- Create general public awareness for high voltage technology

Contact details:

- Prof. Ir. Peter Vaessen P.T.M.Vaessen@tudelft.nl; < Peter.Vaessen@kema.com >



FEASIBILITY DC-FIELD MEASUREMENT TECHNIQUE

Type of project: MSc thesis

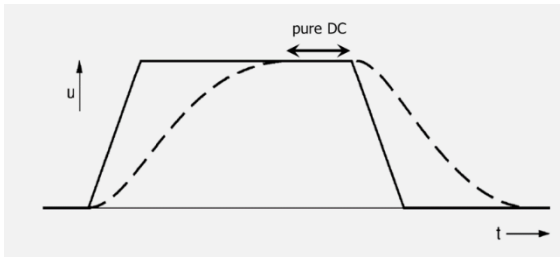

The dotted line represents the space-charge build up



Scope:

Investigate the feasibility of DC field measurement.

Problem definition:

HVDC will have a more prominent presence in the future electricity grid. The development of the DC-field in an insulation medium takes (a long) time, see graph. For testing DC-equipment like cables you must wait a certain time before you can start the test. A non-invasive DC-field measurement allows to monitor the space charge development and gives guidelines for the “waiting-time”.

Methodology:

Perform a feasibility study and a proof-of-principle for selected HVDC equipment together with industry.

Research Objectives:

- Concise literature review
- Design considerations
- Modelling
- Proof-of-principle demonstration

Contact details:

- Prof. Ir. Peter Vaessen < P.T.M.Vaessen@tudelft.nl >; < Peter.Vaessen@kema.com >
- Dr. Ir. Dennis van der Born < D.vanderBorn-2@tudelft.nl >



SUBSTATION INSULATION COORDINATION FOR POSITIVE LIGHTNING.

Type of project: MSc thesis

**Scope:**

Define the positive lightning stroke current for use in substation insulation coordination studies.

Problem definition:

Insulation coordination studies for substations consider very low probabilities of occurrence in the order of 1/100yr to 1/500yr, by considering low probabilities lightning current of > 150 kA. Historically these studies only considered negative lightning flashes, but it is becoming necessary to also consider positive lightning flashes as these make up the majority of flashes above 150 kA.

Methodology:

Perform a literature review to collect all available information on the parameters of positive lightning flashes. Information on the following aspects is needed: 1) lightning current magnitude of positive cloud to ground flashes (2) Equations for estimating the incidence of positive flashes to transmission lines. It may be expected that the incidence will be lower because negative upward leaders will be less likely to form. (3) Corona attenuation constants for lightning surges of positive polarity. (3) Maximum current steepness (di/dt) of the positive polarity lightning strokes.

These parameters are then used to perform comparative insulation coordination studies on a typical substation arrangement to determine the relative severity of positive vs negative flashes on the substation protection.

Research Objectives:

- Extract engineering parameters from the available literature
- Derive a corona damping constant for overhead conductors based on published corona deformation waveshapes.
- Derive striking distance equations based on positive lightning strokes
- Determine if substation lightning coordination studies should be based on positive lightning flashes.

Contact details:

- Supervisor: C.S.Engelbrecht <c.s.engelbrecht@tudelft.nl>



IMPLEMENTATION OF MODULAR MULTILEVEL CONVERTER CONTROL ALGORITHMS TO GENERATE ARBITRARY COMPLEX WAVESHAPES FOR HV TESTING

Type of project: <MSc thesis>

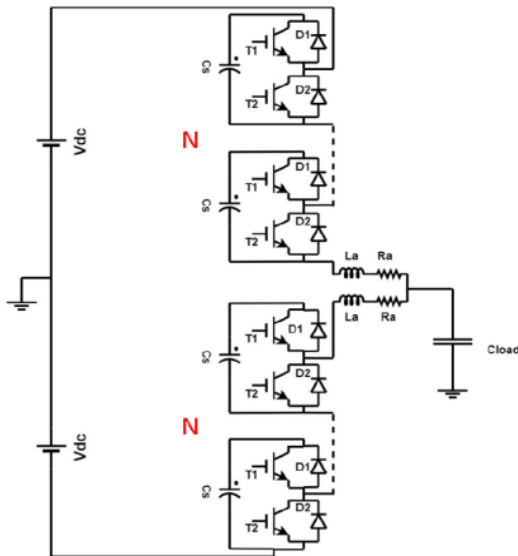

Typhoon HIL 404

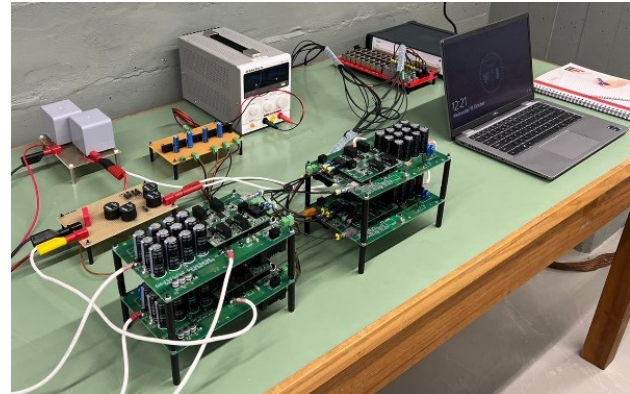

Scope:

The goal is to understand and design control algorithms and employ different modulation techniques for Modular Multilevel Converter (MMC) to generate complex high-voltage waveforms for HV Testing.

Problem definition:

Modular Multi-Level Converters (MMC) have gained immense popularity in the backdrop of Energy Transition. TU Delft and KEMA laboratories are collaborating to create an Modular Multi Level Converter (MMC) based universal High-Voltage testing device capable of generating High Voltage Arbitrary Waveforms. A scale-down hardware prototype of MMC based Arbitrary Waveform Generator (AWG) has been developed and is being experimented with. A basic control algorithm of the system is already designed and implemented in MATLAB-Simulink. The task is to develop a deep understanding of MMC and expand the knowledge base of the generation of complex shapes by performing extensive experiments with control algorithms and modulation techniques. Typhoon HIL System has proven to be an efficient controller of the MMC-based HV AWG which can generate very accurate gate pulses for the switches in order to generate complex wave shapes.

Methodology:

The main focus of the project is to develop a deeper understanding of MMC operation for the generation of complex arbitrary waveforms.

Research Objectives:

- Learn the basic working principles of MMC and its operation & control techniques to generate complex arbitrary waveforms
- Establish an understanding of the design & operation of already developed setup
- Discover and implement effective control algorithms and modulation techniques

Contact details:

- PhD student: Sohrab Ghafoor, < s.ghafoor-1@tudelft.nl >
- Supervisor: Dr. Ir. M. Ghaffarian Niasar, < M.GhaffarianNiasar@tudelft.nl >



AN INNOVATIVE CALIBRATION METHOD WITH PCBs FOR PEA SPACE CHARGE MEASUREMENT

Type of project: <MSc thesis>

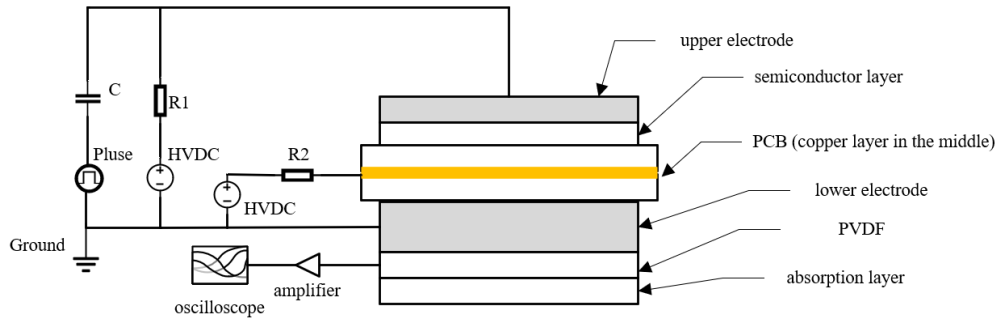

Scope:

We are focusing on the development of an innovative calibration method with PCBs for PEA space charge measurement.

Problem definition:

Since the continuous accumulation of space charge in the cable will directly affect the electric field distribution inside insulation and reduce the life of insulating materials, accurate experimental means to measure the distribution of space charge is an effective way to characterize the aging degree of insulating materials. As the most common space charge measurement method, PEA's calibration and characterization are extremely important for the accuracy of measurement results.

Methodology:

Firstly, we need to use electrical knowledge to derive the calculation formula of space charge and the related loss of acoustic wave propagation. Then, an innovative PCB will be made for better calibration. In the next stage, we need more practical experiments to test and adjust the calibration method.

Research Objectives:

- To build a completed derivation system around the space charge and acoustic wave.
- To make a special PCB structure with a copper layer in the middle.
- To design a series of experiments to test and optimize the whole calibration method.

Contact details:

- PhD student: Xuliang YU, < x.yu-6@tudelft.nl >
- Supervisor: Dr. Ir. M. Ghaffarian Niasar, < m.ghaffarianniasar@tudelft.nl >



COUPLING EFFECTS BETWEEN DC AND AC CIRCUITS ON OVERHEAD LINES:

Type of project: MSc thesis

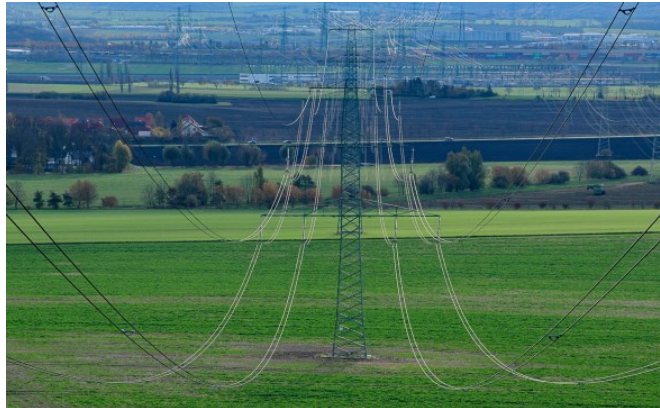

Scope:

identify key issues that should be considered with respect to coupling effects between DC and AC systems.

Problem definition:

Hybrid AC/DC overhead lines are becoming an attractive alternative to increase the power transfer down existing power line corridors. A concern in this regard is how to deal with the electromagnetic coupling between the circuits which can give rise to adverse effects. Although this problem has been investigated in the past, there is a need to scope the extent of the problem if hybrid lines would be implemented in the Dutch transmission network.

Methodology:

The bulk of the project comprises a literature review to collect all available information on coupling effects and solutions in Hybrid systems. The literature study should be complimented with overvoltage studies to demonstrate possible implications for the Dutch transmission systems. A special focus should be on the excitation of harmonic resonances which could exacerbate those already present in the system due to the presence of long cable networks.

Research Objectives:

- Provide an overview of important coupling effects in hybrid AC/DC systems if applied to the Dutch network.
- Establish appropriate network models for the study of coupling effects
- Identify priorities for further study and mitigation of such coupling effects

Contact details:

- Supervisor: C.S.Engelbrecht < c.s.engelbrecht@tudelft.nl >

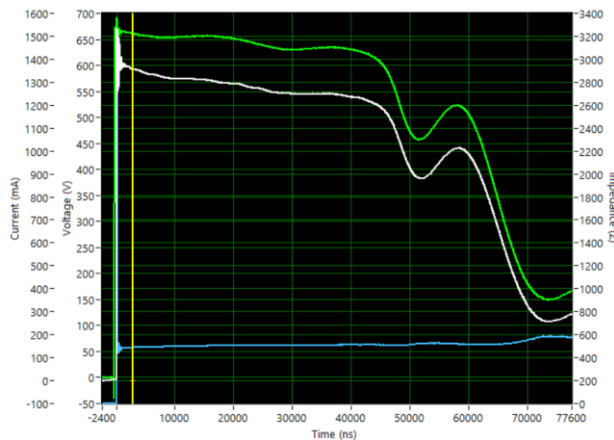

SQUARE WAVE PULSER FOR MEASURING EARTH ELECTRODES.
Type of project: MSc thesis

(a) Pulse Waveforms



(b) Possible H-bridge Solution

Scope:

The aim with this project is to design a pulser that can be used for transient measurement of transmission line grounding.

Problem definition:

EPRI has developed the “Zed-meter” for measuring the transient impedance of transmission line earth electrodes. This system can be improved by developing a solid-state square wave generator with a fast-rising pulse.

Methodology:

The student will develop a high voltage solid state pulser with the following characteristics:
 (1) Pulse shape – square pulse. (2) Pulse width – 2 μ s to 4 μ s. (3) rise time – < 40 ns
 (4) Voltage amplitude - 400 V to 600 V (5) Short circuit current 2.5 A to 4 A.
 The pulser should be battery driven and be as portable as possible.

Research Objectives:

- Study the pulser application to know the requirements
- Investigate the existing H-bridge solution and find the possible rise time
- Optimize the choice of switches and other limiting factors on the existing H-bridge solution for lowest possible rise time
- Adapt the H-bridge PCB as per new design and demonstrate the performance

Contact details:

- Supervisor: C.S.Engelbrecht < c.s.engelbrecht@tudelft.nl >



HIGH-FREQUENCY ANALYSIS OF EARTH ELECTRODE IMPEDANCE:

Type of project: MSc thesis



Scope:

Perform, analyse and model the high-frequency behaviour of simple and realistic earth electrodes.

Problem definition:

EPRI has developed the “Zed-meter” for measuring the transient impedance of transmission line earth electrodes. This instrument can be used to measure the high-frequency transient behaviour of ground electrodes. Up to now the measurements were analysed in the time-domain to obtain an estimate of the impulse impedance. A method has been developed to use the FFT to also determine the frequency dependent behaviour of the electrode, which can be used for the development of models in the Electromagnetic Transients Program (EMTP). This method needs to be verified against actual measurements and modelling of simple and complex earth electrodes.

Methodology:

The student will start with a literature review on high-frequency behaviour of earth electrodes. The Zed meter will be used to perform measurements on a range of simple earth electrodes which can be modelled in software that can calculate the frequency response of earth electrodes (XGS-Lab). The measurement results will be compared with those of XGS-Lab to verify the Zed-meter frequency analysis method. Finally, routines will be created to convert the Zed-meter results into EMTP Frequency dependent models.

Research Objectives:

- Finalize the Frequency-domain analysis of Zed meter results
- Compare practical measurement and modelling results.
- Establish a methodology for creating EMTP models

Contact details:

- Supervisor: C.S.Engelbrecht < c.s.engelbrecht@tudelft.nl >



NATURAL ARC EXTINCTION IN AIR

Type of project: MSc thesis



Scope:

Investigate by study and testing the natural extinction of arcs in (atmospheric) air

Problem definition:

Substation earthing switches (and other earthing devices) have to interrupt induced currents (order of magnitude up to 1000 A and 2000 V). Literature describes characteristics of arcs in air in terms of arc length and arc reach. However, no clear reference is made to electrode distance at which natural extinction of the arc will occur. To assess potential solution for earthing devices, better understanding of the natural extinction has to be investigated.

Methodology:

The student will start with literature study on the behaviour of arcs in (atmospheric) air and interruption of those arcs. Secondly, a test circuit should be realized with the available test equipment and sources of the HV lab to test (natural) extinction of arcs in (atmospheric) air. In the test circuit natural extinction of moving electrodes should be investigated. Based on literature and performed tests a model (expression) should be developed for the description of natural arc extinction in air.

Research Objectives:

- Develop test circuit with the available equipment in the HV lab to test natural air extinction
- Develop a model (expression) predicting the natural extinction of arcs in atmospheric air

Contact details:

- Supervisor: C.S.Engelbrecht < c.s.engelbrecht@tudelft.nl >
- Contact DNV: Ebbo de Meulemeester



BREAKDOWN IN HVDC GIS

Type of project: MSc thesis

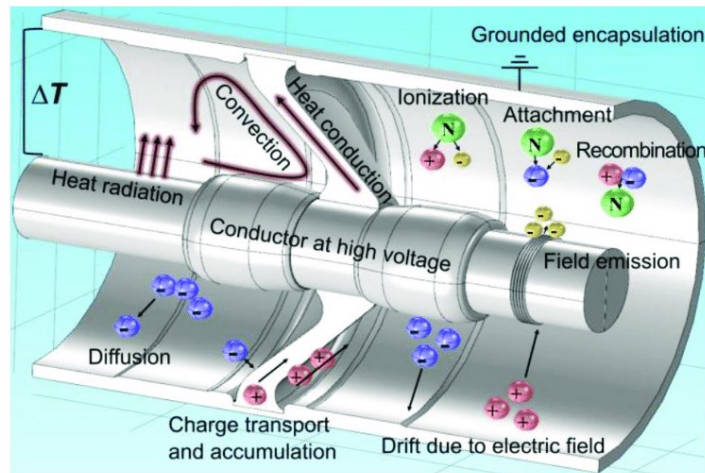
**Scope:**

Predict and verify the effect of conditions on breakdown voltage (or field) which are specifically for DC GIS.

Problem definition:

Breakdown in DC GIS is initiated by phenomena well-known from classical AC GIS. However for DC GIS also additional mechanisms and parameters have a decisive (or more dominant) role, such as temperature, surface condition). These additional parameters are less well controlled and the effects may be less clear or more difficult to identify.

Methodology:

The student will start with literature study (e.g. Cigre) on breakdown phenomena especially related to breakdown in HVDC GIS. Potential mechanism to be studied are influence of temperature gradients inside GIS or surface condition (surface resistivity) of spacer insulators in GIS. For the one or two selected mechanisms a (simplified) analytical expression should be developed that predicts the effect. This analytical expression should be verified with simulations and preferably be tested in a simplified HV test set-up (e.g. with simplified insulator model and at reduced DC voltages).

Research Objectives:

- Study breakdown phenomena especially related to HV DC GIS
- Develop analytical expression (approximation) of the effect of the parameter
- Verify the approximation with simulation and preferable simplified tests

Contact details:

- Supervisor: C.S.Engelbrecht <c.s.engelbrecht@tudelft.nl>
- Contact DNV: Jiayang Wu / Ebbo de Meulemeester



TECHNICAL REQUIREMENTS FOR HVDC GIS

Type of project: MSc

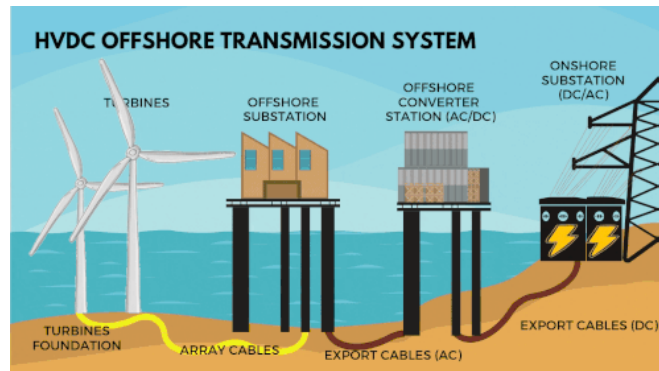

Scope:

Identify and clarify the main (electrotechnical) deviations of DC GIS (exclusive of CB) compared to AC GIS and propose and substantiate additional requirements for specification (design and testing).

Problem definition:

HVDC (inter)connections are already being used for a very long time. Classically, this is a point-to-point connection, typically requiring only limited HVDC switchgear equipment (e.g. disconnector, earthing switch, etc.). If necessary, this is realized in a so-called AIS (air insulated substation). However, the application of offshore HVDC and the preparation for HVDC grids requires that substations have to be realized on offshore substations with a minimum footprint. This can be realized with GIS (gas insulated substation). GIS is already known for a long time for AC applications. However, standards for DC GIS are not yet available or under consideration, implying that specification for DC GIS is also not mature.

Methodology:

The student will start with literature study (e.g. Cigre) on design and behaviour of HVDC GIS and standardization for DC and AC GIS. Based on the study the main deviations in behaviour, performance and capabilities for AC and DC GIS should be identified and clarified. To ensure reliable operation of the DC GIS over its life, additional (type or routine) tests may be required. The rationale for such tests should be provided as well as a (proposed) test procedure and requirements.

Finally, the necessary additional or deviating requirements (for design and testing) should be proposed for the specification of DC GIS.

Research Objectives:

- Identify and clarify the main (electrotechnical) differences in behaviour, performance and capabilities between DC and AC GIS
- Propose additional (type and routine) tests for DC GIS
- Propose additional requirements for the specification of DC GIS

Contact details:

- Supervisor: C.S.Engelbrecht < c.s.engelbrecht@tudelft.nl >
- Contact DNV: Jiayang Wu / Ebbo de Meulemeester

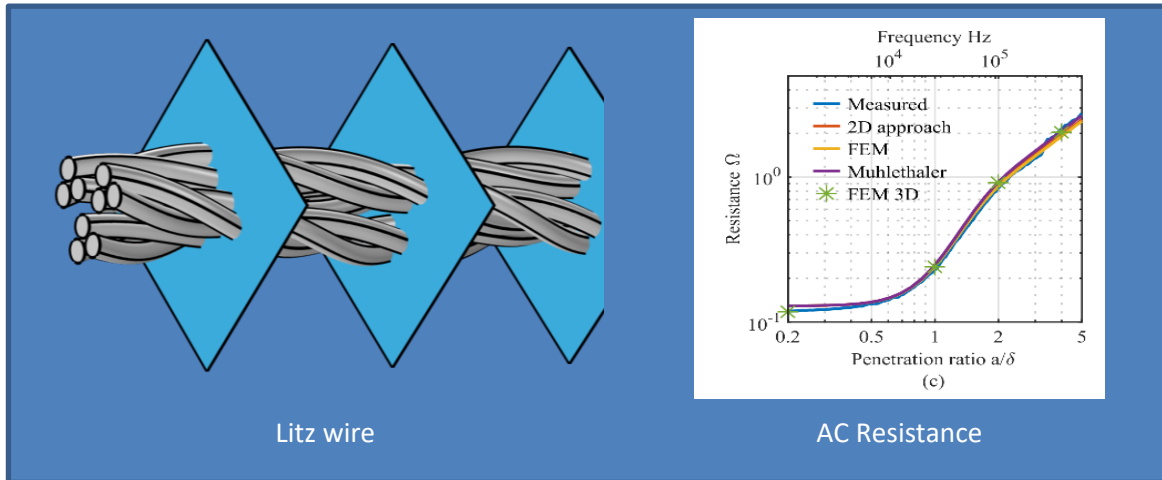

WINDING LOSS ESTIMATION IN MAGNETIC COMPONENTS WITH LITZ WIRE
Type of project: Extra

Scope:

The goal is to estimate ac resistance in magnetic components with Litz wire.

Problem definition:

In order to suppress the eddy current induced winding loss in magnetic components, Litz wires are widely used. Through twisting the strand and forcing strands have equal current, Litz wires can significantly reduce the eddy current in certain frequency range. However, Litz wires have complex structure, and it is expensive to compute with finite element model (FEM) due to dense meshing. Therefore, it is better to find a approach to model it with fast computation speed and reasonable accuracy.

Methodology:

The project needs to analyse the AC resistance of magnetic components with Litz wire. First, understand the mechanism of AC resistance and summarize the methods used in literature. Then, program the winding loss estimation methods with Matlab. Model the magnetic components with COMSOL and compare the result with the result from the program.

Research Objectives:

- Literature review of the AC resistance calculation method.
- Establish FEM models for magnetic components with Litz wire.
- Program the code for winding loss estimation.

Contact details:

- PhD student: Tianming Luo, <T.Luo-1@tudelft.nl> ,
- Supervisor: Mohamad G Niasar, <M.GhaffarianNiasar@tudelft.nl> >
 Peter Vaessen <P.T.M.Vaessen@tudelft.nl>



DESIGN OF A HV AMPLIFIER WITH MAXIMUM SLEW RATE AND BANDWIDTH POSSIBLE

Type of project: <Extra project >

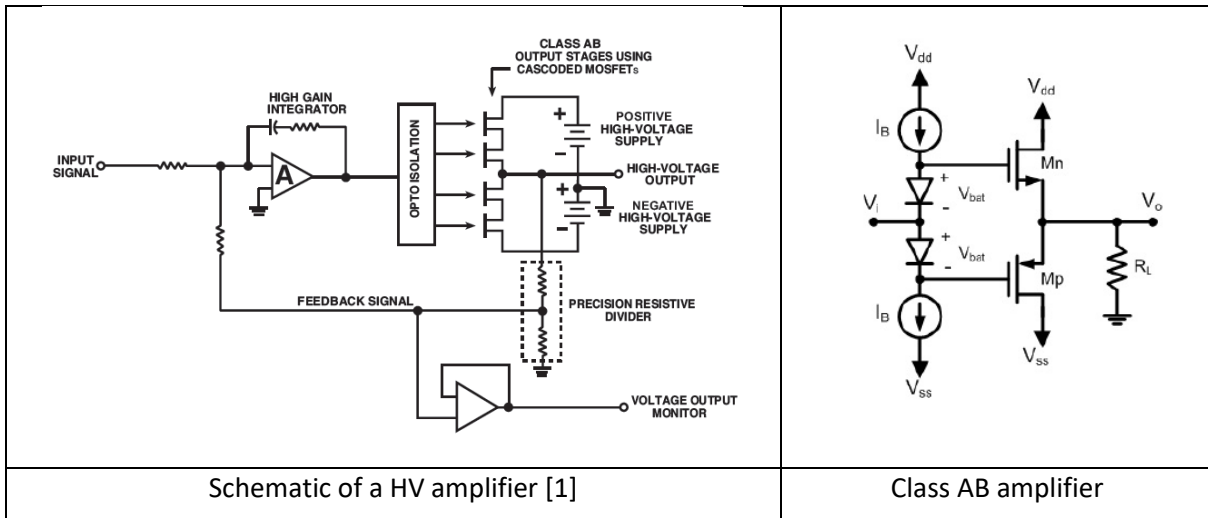

Scope:

The goal is to design a HV amplifier with maximum slew rate and bandwidth possible and analyse the different trade-offs in scaling up the voltage, current rating, and bandwidth of such an amplifier.

Problem definition:

Currently, an HV amplifier is used to generate arbitrary wave shapes along with a function generator. There are inherent problems of such an HV amplifier with scaling up the voltage level, slew rate, bandwidth and current rating.

Methodology:

The main focus of this project is to understand different trade-offs in designing an HV amplifier in order to scale up the voltage level, slew rate, bandwidth and current rating. It will involve a theoretical understanding of designing a class AB amplifier where the linear region of semiconductor devices is used. Also, these trade-offs will be shown with the circuit simulator.

Research Objectives:

- Literature review on designing a class AB amplifier at high voltage
- Analyse trade-offs to scale up the voltage level, slew rate, bandwidth and current rating
- Simulate the design with the circuit simulator

Contact details:

- Supervisor: <Mohamad Ghaffarian Niasar, m.ghaffarianniasar@tudelft.nl>

[1] Measurement and Power solutions, Product and system catalog, Trek product brochure [online] Available at: <http://www.trekinc.com/pdf/Trek-Amp-ESVM-2015.pdf> [Accessed 28th October 2019].

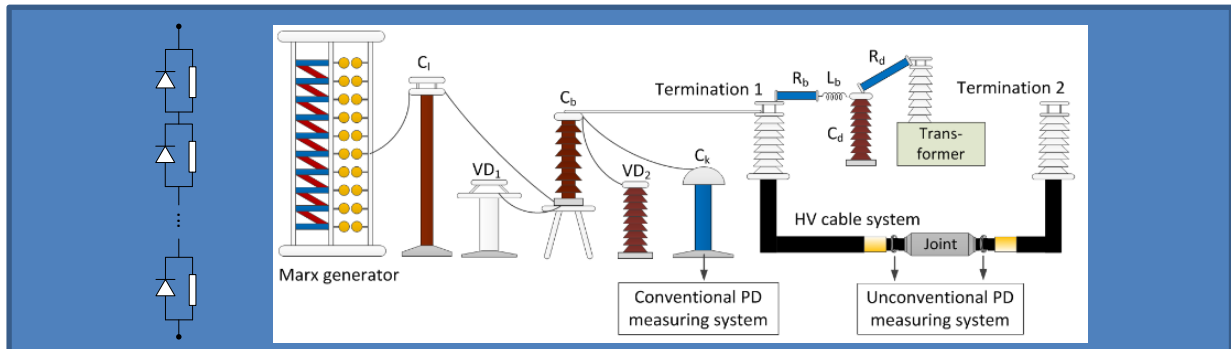

CONSTRUCTION OF A HIGH VOLTAGE DIODE FOR TRANSIENT OVERVOLTAGE TESTING OF HVDC EXTRUDED CABLE SYSTEMS WITH EXTREME TIME CONSTANTS
Type of project: < Extra Project >

Scope:

To design and construct a 30 kV high voltage diode and use it together with an impulse generator to create transient over-voltages with extreme time constants.

Problem definition:

Cable faults simulated on 320 kV UDC XLPE cable with length 210km shows that for a pole-to-ground fault at the converter terminal, TOV can occur with a peak voltage U_p of $1.65U_{DC}$ and time-to-peak of approximately 3 ms. Generating such type of lightning overvoltage with such time to peak with the available equipment is a challenge. Considering the development of 500 kV and higher cable systems it is clear that innovative test circuitry is needed to generate actual waveforms seen by the equipment. In a previous study it is shown that utilizing a high voltage diode in a conventional lightning overvoltage circuitry can help achieving such extreme time constant. The goal of the project is to first make one high voltage diode using series connection of low voltage diodes. Thereafter we will use this diode in a traditional lightning test circuitry and will evaluate the time constants or the waveform produced.

Methodology:

The work consists of circuit simulation as well as laboratory work. The simulation consists of modelling lightning impulse circuitry including the high voltage diode. The laboratory work consists of making high voltage diode, and using it in a lightning overvoltage test setup to evaluate the time constants created by the new circuitry.

Research Objectives:

- Review previous work done about this topic
- Construct a high voltage 30 kV diode using series connection of low voltage diodes.
- Use the constructed diode in a lightning impulse test circuitry and perform measurement and characterize the archived waveforms.

Contact details:

 TUD Supervisors : Mohamad Ghaffarian Niasar, M.GhaffarianNiasar@tudelft.nl

 & Peter Vaessen: P.T.M.Vaessen@tudelft.nl

CASE STUDY ON HIGH VOLTAGE CABLE TESTING ON OFFSHORE ASSETS

Type of project: MSc thesis

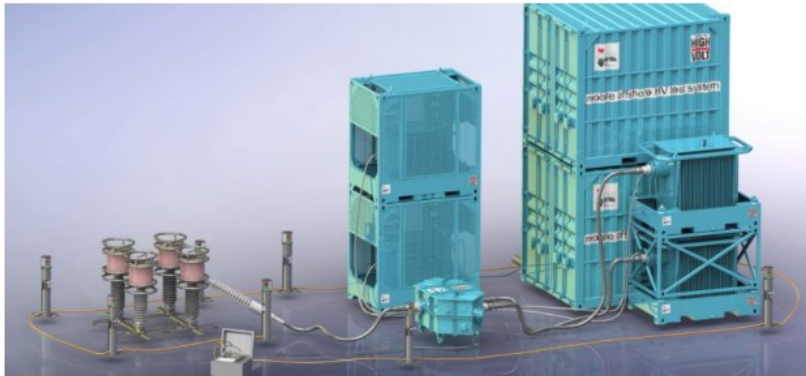

New test technology for 66kV offshore windfarms source <https://www.jdrcables.com>

Scope:

Develop a suitable and quality effective testing solution for Offshore High Voltage Assets. Taking in to account the rapidly changing cable designs and voltage levels for the next 10 years.

Problem definition:

As the offshore wind industry continues to expand at a high rate, it is critical for windfarm operators that post installation tests have the best chance of detecting any defects that could later lead to failures. According to the Offshore Renewable Energy Catapult (ORE Catapult) subsea power cable system failures (including cable accessories) are a frequent issue, causing approximately 75-80% of offshore wind insurance claims despite only making up around 9% of the total cost of a windfarm. The total cost to operators in 2019 was over £1 billion in lost revenue, and the figure is climbing year on year.

Of the cable system failures reported by the ORE Catapult, approximately half were caused by problems during the installation process. This highlights the issue of traditional offshore test methods failing to detect defects arising during installation.

How to improve test technology's and/or combine ways to overcome the current and future challenges.

Methodology:

Perform a literature survey into the physics of offshore high voltage cable testing, create a simulation model and develop a proof-of-principle for a test installation that captures the principal characteristics and can be further developed into a compliance test installation.

Research Objectives:

- Concise literature review
- Identify offshore high voltage testing challenges and chances
- Combine chances in to a working module
- Proof-of-principle test installation

Contact details:

- Prof. Ir. Peter Vaessen P.T.M.Vaessen@tudelft.nl; Peter.Vaessen@kema.com
- Dr. Ir. Mohamad Ghaffarian Niasar M.GhaffarianNiasar@tudelft.nl



HIGH VOLTAGE DEMONSTRATIONS TOOLBOX FOR GENERAL PUBLIC

Type of project: Extra Project



Scope:

Develop a toolbox with a set of amazing high voltage demonstrations for the general public, and realise one or more of the demos.

Problem definition:

High Voltage Technology is one of the key enablers of the Energy Transition and we should achieve more attention for this job area to the general public and (potential) students by have some “out-of-the-box” demonstrations that we can perform in the High Voltage Lab.

Methodology:

Perform a survey to come up with a list of high voltage demonstrations and together with HVT staff and technicians realise some of these.

Objectives:

- Getting to know high voltage technologies, hands-on
- Create general public awareness for this work-area
- Realisation of inspirational and educative demonstrations

Contact details:

- Prof. Ir. Peter Vaessen P.T.M.Vaessen@tudelft.nl
- Ir. Imke Splinter I.M.Splinter@tudelft.nl



FEASIBILITY FAST HYBRID MV CIRCUIT BREAKER FOR PV FARM INTEGRATION

Type of project: MSc thesis

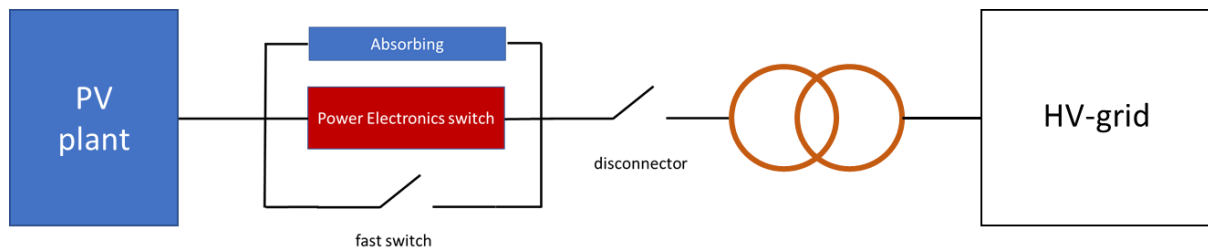

Scope:

Investigate the feasibility of a medium voltage hybrid AC circuit breaker as part of a new protection method that can clear a short circuit on the PV plant side so fast that the (conventional) protection at 110kV and 150kV level does not need to trigger.

Problem definition:

To make optimal use of the existing transmission capacity PV plants can be connected directly to overhead lines without a complete substation, only if they can be switched off that fast, that the overlaying grid is not involved. The principle of the MV CB is based on commutating the short circuit current to a power electronic switch, which does the actual interruption, this concept, is already used in HVDC -breakers, the fast switch can be of vacuum type.

Methodology:

Perform a literature survey in collaboration with industry experts, e.g., TenneT, Eaton, Stedin, Alliander and proof-of-principle.

Research Objectives:

- Concise literature review
- Design considerations
- Modelling
- Proof-of-principle demonstration

Contact details:

- Prof. Ir. Peter Vaessen P.T.M.Vaessen@tudelft.nl; Peter.Vaessen@kema.com
- Dr. Ir. Mohamad Ghaffarian Niasar M.GhaffarianNiasar@tudelft.nl
- Ir. André Lathouwers (TenneT) and Ir. Martin Binnendijk (Eaton)



PROOF-OF-PRINCIPLE FOR SOLAR STORM COMPLIANCE TEST INSTALLATION

Type of project: MSc thesis

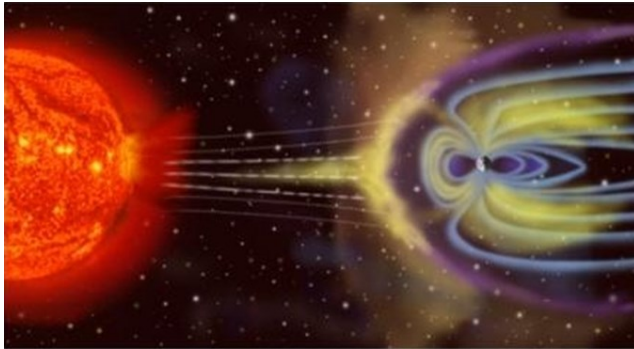

Solar storm hitting Earth magnetic field source www.geomag.bgs.ac.uk

Scope:

Develop a proof-of-principle for a solar storm compliance test installation for power grid electronic sensors and actuators

Problem definition:

Solar (or geomagnetic) storms and their effect on the electricity supply system gained renewed interest of the international community since the start of the 25th 11-year solar cycle in December 2019, due to the potential disturbance on communications and electronics in the (smart) Power System.

A solar storm is basically a huge fluctuating stream of high speed, high energetic charged particles from the sun that is heading towards earth. Five storm categories 1 to 5 are identified, with each successive category the amount of charged particles increase 10-fold.

How to test power grid (electronic) equipment for solar storm compliance?

Methodology:

Perform a literature survey into the physics of solar storms, create a simulation model and develop a proof-of-principle for a test installation that captures the principal characteristics and can be further developed into a compliance test installation.

Research Objectives:

- Concise literature review
- Identify solar storm characteristics
- Simulation model
- Proof-of-principle test installation

Contact details:

- Prof. Ir. Peter Vaessen P.T.M.Vaessen@tudelft.nl; Peter.Vaessen@kema.com
- Dr. Ir. Mohamad Ghaffarian Niasar M.GhaffarianNiasar@tudelft.nl
- Sebastiaan Barlagen Sebastiaan.Barlagen@tennet.eu



GENERATING 100-250 TIMES NOMINAL CURRENT PULSES FOR LPIT TESTING

Type of project: MSc thesis

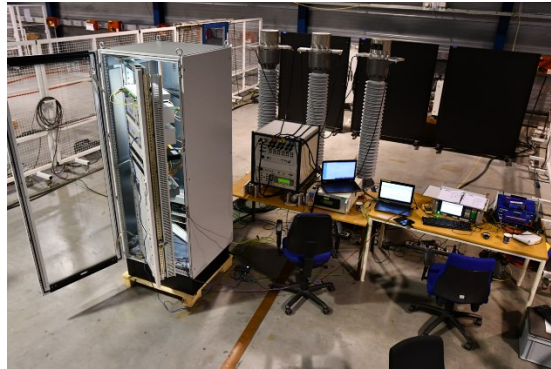

150kV LPIT setup at KEMA Labs

Scope:

Develop and realise a test circuit that can generate current pulses in the range of 250A to 500A and duration between 5ms and 1s, for future tests on Low Power Instrument Transformers (LPIT) for the high voltage grid.

Problem definition:

Low Power Instrument Transformers (LPIT) for current (and voltage) measurement are more and more used in the power system. LPITs are used for protection relays and energy metering and deliver digital output signals for a wide frequency band. In order to check the functionality (and accuracy) tests signals of 100 to 250 times the nominal current are proposed.

Methodology:

Perform a literature survey, including emerging standards, develop and realise a test circuit that is able to generate the specified current pulses and demonstrate this at a LPIT test performed at KEMA Labs

Research Objectives:

- Literature review
- Requirements document
- Design and build of at test circuit
- Validate and demonstration of functionality

Contact details:

- Prof. Ir. Peter Vaessen P.T.M.Vaessen@tudelft.nl; Peter.Vaessen@kema.com
- Dr. Ir. Mohamad Ghaffarian Niasar M.GhaffarianNiasar@tudelft.nl
- Mac Achterkamp head of MPSA Lab Arnhem Marc.Achterkamp@kema.com

**KEMA** Labs

DESIGN AND SIMULATION OF HIGH-POWER WINDINGS FOR MEDIUM-FREQUENCY TRANSFORMERS (MFT)

Type of project: MSc thesis

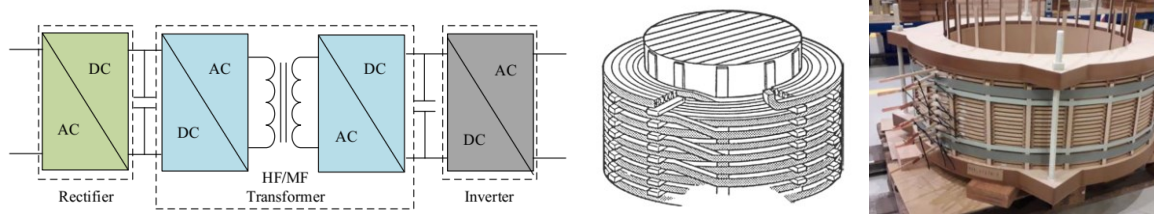

Scope:

To design and simulation HV and LV windings for an MVA scale medium-voltage, medium-frequency transformer (MFT).

Problem definition:

There is a rising trend in using solid-state transformers in power delivery. While kW-scale SSTs are well-known and widely used in modern industries, there are some unclear aspects of MVA-scale SSTs. The most important part of an SST is the medium-frequency transformer (MFT), and its significance is even higher when a few MVA of output power is needed. Investigation of parasitic parameters such as AC resistance and capacitances, together with the mechanical design to satisfy thermal management and mechanical endurance against forces, is required.

Methodology:

The work involves FEM simulation using COMSOL or ANSYS to investigate parasitic parameters such as AC resistance. Insulation design and thermal management are desired.

Research Objectives:

- Literature review of SSTs, transformer windings, and parasitic parameters
- Design of HV and LV winding to satisfy the desired considerations for an MVA-scale SST
- FEM simulation of designed windings and comparison
- Investigation of the HF impact on the AC resistance, insulation, and thermal performance of the windings

Contact details:

- Dr. Ir. Mohamad Ghaffarian Niasar M.GhaffarianNiasar@tudelft.nl



DESIGN AND IMPLEMENTATION OF A 12.5 KW THREE-PHASE INVERTER

Type of project: MSc thesis

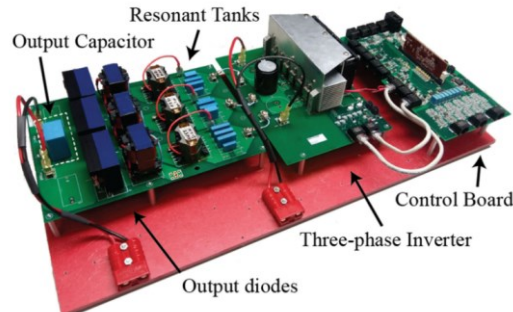
**Scope:**

To design, simulation, fabrication, and test of a 12.5 kW three-phase inverter for testing of a medium-frequency transformer (MFT).

Problem definition:

Medium-frequency transformer (MFT) is the most important part of a solid-state transformer (SST). The main idea is to increase the operating frequency to reduce the size and weight of the transformer. As this technology is developing, some testing applications are not well-known yet. To test an MFT, it is required to apply a medium-frequency (~400 Hz) waveform to the transformer to investigate the losses and other important issues. A 12.5 kW demonstrator is going to design to develop the approach of testing for the full-scale cases. The design and implementation of the three-phase LLC inverter is desired.

Methodology:

The work involves circuit simulation using PSpice or PSIM, PCB design using Altium Designer, fabrication, and testing. A level of knowledge in the aforementioned software is required.

Research Objectives:

- Literature review of resonant converters, LLC in particular
- Developing the control scheme for a three-phase LLC inverter
- Design of a 10 kW LLC inverter regarding the parameters of the three-phase demonstrator transformer
- PCB design and fabrication
- Testing and experimental validation

Contact details:

- Reza Mirzadarani R.Mirzadarani@tudelft.nl
- Dr. Ir. Mohamad Ghaffarian Niasar M.GhaffarianNiasar@tudelft.nl



HIGH FREQUENCY ACCELERATED AGING OF INSULATION MATERIAL FR-4 FOR MEDIUM VOLTAGE PCB PLANAR TRANSFORMER

Type of project: <MSc thesis/ Extra Project>

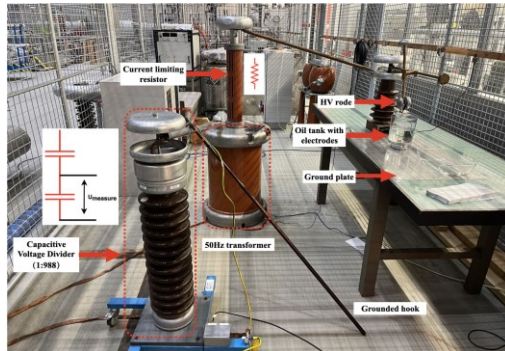

Fig.1 Set-up for FR4 aging and breakdown tests



Fig.2 Breakdown of PCB electrodes (FR4)

Scope:

The general goal of this project is to thoroughly investigate the insulation properties (ramp sinusoidal breakdown, high-frequency aging, PD inception voltage) of the insulation material FR4 for the further design of the medium voltage PCB planar transformer (30-35kV insulation level)

Problem definition:

Due to high power density, low leakage inductance, better thermal performance, compact device size and lighter weight and ease of assembly, medium voltage (MV) planar transformer is currently under rapid development and FR-4 is the common insulation material. However, there is limited literature related to the investigation of the properties of this material. The study of this project would bring more indications on the insulation thickness selection and the high voltage performance of FR-4.

Methodology:

- HF accelerated aging (50Hz, 500Hz, 5kHz, 50kHz, 500kHz) of the PCB electrodes under different temperatures (25C° and 80C°) with the thickness of 0.71mm or 0.36mm.
- HV ramp sinusoidal breakdown (short-term) of the PCB electrodes (0.36mm between two layers) with the frequency of 50Hz, 500Hz, 5kHz, 50kHz, 500kHz at 25C° and 80C°.
- HV ramp sinusoidal interlayer breakdown of the PCB electrodes with the distance of 4 and 8mm
- HF accelerated interlayer aging of the PCB electrodes with the distance of 4 and 8mm
- Partial discharge inception voltage and pattern measurement — analysis

Research Objectives:

- Thorough literature review about FR-4 HF aging and HV ramp breakdown
- Weibull distribution analysis of the obtained experimental data
- Design representative electrodes based on Altium Designer
- Investigation the ramp breakdown and aging of the material at different frequencies and temperatures

Contact details:

- PhD student: Weichuan Zhao, < W.Zhao-3@tudelft.nl >
- Supervisor: Mohamad Ghaffarian Niasar, < M.GhaffarianNiasar@tudelft.nl >



TO RESEARCH IF A FAILURE ON EXISTING GIS 380 KV CAN BE PREDICTED BY PD-MEASUREMENT

Type of project: Internship/Extra project

Scope:

To research in the ESP-lab on the GIS which method would be suitable to predict the condition of the GIS 380 kV at Meeden.

Problem definition:

The GIS 380 kV at substation Meeden shows whiskers at its internal due to aging, which may finally cause flashovers inside the GIS. TenneT wants to verify a method to enable the forecasting of a weakening of the dielectric strength as a result of these whiskers by pd-measuring.

Methodology:

The GIS at ESP-lab is of the same type as the GIS in the substation Meeden 380. It appears that after 20 years whiskers have been developed, causing internal flashovers. It is the intention to exchange the inner conductor of the ESP-installation with the inner conductor of the installation in Meeden and to verify with which PD-measurement a prediction of the condition of the bays at Meeden can be forecasted.

Research Objectives:

Verify by which PD-measurement at which voltage level the possibility of restrike can be predicted for the existing installations at Meeden and Eemshaven.

Contact details:

- Ir. André Lathouwers a.g.a.lathouwers@tudelft.nl
- Dr. Ir. Dennis van der Born < D.vanderBorn-2@tudelft.nl >

Part of the project is in cooperation with Siemens Energy, Stedin and TenneT

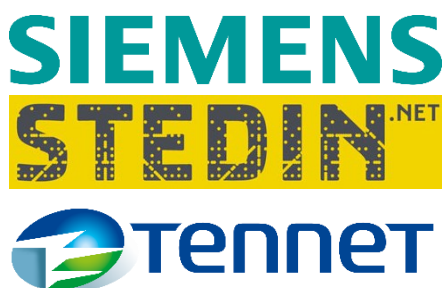

LIFE EXTENSION (GAS INSULATED) SWITCHGEAR

Type of project: MSc thesis



Scope:

Develop method to assess the feasibility of life extension for (gas insulated) switchgear.

Problem definition:

Owners consider for various reasons life extension of (old) switchgear beyond the default or declared life of the equipment. Reasons could be economic, congested grid or otherwise. DNV performs such assessments for various (international) Clients.

Switchgear has ageing mechanisms deviating from for example cables or transformers, and different methods to counteract ageing. Besides physical ageing, also other factors may influence the end-of-life of switchgear (and more T&D equipment in general). The assessment goes beyond the performance of diagnostic measurements and remaining life assessment.

Methodology:

The student should start with literature study on ageing mechanisms, aspects determining end-of-life and defining end-of-life initiators. A (scoring) method shall be developed for the severity status of the end-of-life initiators and methods shall be proposed how the parameters determining the severity can be determined (amongst others but not limited to condition assessment). The severity shall also take into account potential mitigation methods. Finally it shall be determined whether life extension is feasible and under which conditions.

Note: The intention of the work is not to develop or focus on condition assessment (methods).

Research Objectives:

- Determine end-of-life initiators for gas insulated switchgear
- Propose scoring method and method to assess the severity of end-of-life initiators
- Develop assessment method for assessing feasibility for life extension
- Develop a tool, identifying "Simple cases" and "Complex Cases". For "Simple cases", high level advice or indication should be provided.

Contact details:

- Supervisor: C.S.Engelbrecht < c.s.engelbrecht@tudelft.nl >
- Contact DNV: Jiayang Wu / Ebbo de Meulemeester

