

Workflow Management,

“the” challenge for health care



R.A. Breas

Erasmus University Rotterdam
Master’s thesis Informatics & Economics

Date: May 24, 2007
Author: R.A. Breas MSc.
199227

Supervisors: Dr. Ir. J. van den Berg (Erasmus University Rotterdam)
Dr. Ir. N.W.S. Bruens (Erasmus MC)
Drs. H. van Nispen tot Sevenaer – Jansen (Erasmus MC)

Second Supervisor: Dr. M.W. Guah (Erasmus University Rotterdam)

Preface

After nine months of research and hard work this Master Thesis saw the light of day. In this period, I learned very much. Not only did I learn more about doing research, but also about practical skills such as giving advice, talking multiple “languages” within the same organisation and creating a social basis for change. I furthermore developed my skills, both on professional level as on personal level during this period. My internship prepared me for what to expect in an organization as a worker. Other than providing a good work related basis it also gave me a chance for (future) orientation.

Without help from several people, this thesis would not have evolved to the way it is now. For that reason I would like to thank the following people.

First of all I would like to thank my supervisors/coaches, Jan, Nico and Heleen, from the University and the Erasmus MC. Their input and guidance really improved the quality of this thesis. Jan, Nico and Heleen, thanks for your valuable advice, input and feedback during my entire internship. Your different area of expertise brought much profundity to this thesis. I experienced our cooperation as very pleasant.

Jan, I especially want to thank you. You had a great share in my learning curve. Also many thanks for guiding me through the proverbial forest when I lost sight.

For the introducing me with the right people in the Erasmus MC, I would like to thank Peter and of course Nico as well.

Furthermore I would like to thank my colleagues at DI and RvN. Thanks for giving me a helping hand and answers on my questions. Thank you lovely ladies at the secretary of DI for helping me get around and to find a place to work every day. My colleagues from the Research Team of RvN thanks for your support and for collecting research data. Erwin and Erny, thanks for guiding me around in what sometimes looked a little like a jungle. Our cooperation was always fun and very effective. I’ve learned a lot from it.

Of course I would like to thank the people who I interviewed or questioned during that period and also the gynaecologists and nurses with whom I spoke a lot during my research.

And last but not least I would like to thank my parents. They kept standing by my side when I choose to do another Master. I thank them for their belief and (financial) support, without I couldn’t have made it further.

“If you put your mind to it, you can accomplish anything”

Index

CHAPTER 1: INTRODUCTION	7
1.1 CHANGES IN HEALTHCARE	7
1.2 RESEARCH QUESTIONS	7
1.3 METHODOLOGY	8
1.4 STRUCTURE OF THIS THESIS	10
CHAPTER 2: WORKFLOW MANAGEMENT	11
2.1 WORKFLOW MANAGEMENT, A THEORETICAL VIEW	11
2.1.1 <i>Workflow management defined</i>	12
2.1.2 <i>Workflow Processes</i>	13
2.1.3 <i>Workflow processes: Actors, Resources and Roles</i>	14
2.1.4 <i>BPR</i>	15
2.1.5 <i>Improvement of Workflows</i>	16
2.2 WORKFLOW MANAGEMENT IN HEALTH CARE	17
2.2.1 <i>Clinical Pathways</i>	17
2.2.2 <i>Standardisation in health care</i>	18
2.2.3 <i>Order Management</i>	19
2.3 SUPPORTING SYSTEMS IN HEALTH CARE	20
2.3.1 <i>Workflow Management Systems</i>	20
2.3.2 <i>Criteria for successful WfMS</i>	22
2.4 CONCEPTUALIZATION	23
CHAPTER 3: ANALYSIS OF THE OBSTETRIC UNIT	26
3.1.1 <i>Efficiency Researches within Cluster 12</i>	26
3.1.2 <i>Results from the DMO research</i>	28
3.2 PROCESS ANALYSIS	30
3.2.1 <i>General methodology</i>	30
3.2.2 <i>The Case Study</i>	32
3.2.3 <i>Results Process Analysis</i>	33
3.2.4 <i>Administration bottlenecks</i>	35
3.2.5 <i>Coupling the Results</i>	37
3.3 CONCLUSIONS	38
CHAPTER 4: TOWARDS SOLUTIONS	40
4.1 INTEGRAL LOOK OF THE MAIN BOTTLENECKS	40
4.1.1 <i>Lack of alignment</i>	40
4.1.2 <i>Involvement of relevant actors</i>	41
4.1.3 <i>Administrative bottlenecks</i>	42
4.1.4 <i>Management Information</i>	44
4.2 ICT AS SUPPORTIVE SOLUTION	44

4.2.1 Information Architecture.....	45
4.2.2 Solution for the Obstetric unit.....	47
4.2.3 Design process of the information architecture.....	48
4.2.4 Extra functionality in the information architecture.....	49
4.2.5 Data Criteria.....	51
4.3 CONCLUSIONS.....	51
CHAPTER 5: FEASIBILITY OF THE SOLUTIONS.....	53
5.1 SET UP OF THE INTERVIEW.....	53
5.2 RECOGNITION OF THE BOTTLENECKS.....	53
5.2.1 Alignment of processes and ICT.....	54
5.2.2 Involvement of Actors.....	55
5.2.3 Administration.....	56
5.2.4 Management Information.....	57
5.3 DECISION STRUCTURE.....	58
5.4 FEASIBILITY OF A WFMS.....	60
CHAPTER 6: CONCLUSIONS, RECOMMENDATIONS AND FURTHER RESEARCH.....	62
6.1 CONCLUSIONS.....	62
6.1.1 Bottlenecks.....	62
6.1.2 Positioning of WfM.....	63
6.2 RECOMMENDATIONS.....	64
6.3 FURTHER RESEARCH.....	66
6.3.1 Generalization.....	66
6.3.2 Further research RvN.....	67
6.3.3 Further research general bottlenecks.....	67
6.3.4 Further research techniques of information architecture.....	67
6.4 CONCLUSIVE.....	68
APPENDIX 1: PROJECT “RUIMTE VOOR NIEUW”.....	69
APPENDIX 2: TBO.....	71
APPENDIX 3: EXAMPLE TBO RESULT.....	72
APPENDIX 4: FACTS CLUSTER 12.....	73
APPENDIX 5: DOUBLE ADMINISTRATION GYNAECOLOGIST.....	74
APPENDIX 6: DOUBLE ADMINISTRATION NURSES.....	74
APPENDIX 6: DOUBLE ADMINISTRATION NURSES.....	75
APPENDIX 7: QUESTIONS INTERVIEWS.....	76
ABBREVIATIONS.....	77
LITERATURE.....	78

Chapter 1: Introduction

1.1 Changes in Healthcare

Healthcare in general is a dynamic sector. This certainly is the case for the healthcare sector in the Netherlands. In the Netherlands many changes in the health care sector have occurred in the last couple of years. Examples of changes are the new healthcare system that was introduced in the beginning of 2006. New, improved treatments and protocols are introduced in a high rate due to new insights to help and make the patient better. But also changes in legislation imposed by the government, such as the new law on societal entrepreneurship (in Dutch Wet Maatschappelijk Ondernemen (WMO)), have their impact on the dynamic character of healthcare in the Netherlands. The consequence of this dynamic character is the necessity of constant adaptation by healthcare institutions to the environment.

Nowadays it is a trend for healthcare providers to have more cooperation with each other (Anyanwu et al; 2003). These cooperations arise from an increased complexity of healthcare with their many sub-disciplines available and need to help the patient in an optimal way. A common approach is clinical pathway management. This describes the different stages from the first consultation with the physician till the final check-up when receiving care for the treatment of an illness. An example of a patient flow is the “Mama” policlinic where women come with a suspicion of breast cancer. In one day different diagnostic tests are done, instead of spreading them on different days when the patient had to come back to the hospital. A diagnosis will be known the same way, instead of the couple of weeks that usually was common and necessary for the test results being ready. This patient flow takes away a lot of uncertainty for the patient which is helped in a more profound way. At the other hand health care professionals work more efficiently by eliminating unnecessary appointments with the patient.

Healthcare providers have to deliver high quality while at the same time costs have to be reduced. This has precipitated a review and upgrade of clinical and administrative protocols and the increased use of information systems to improve efficiency of processes. Healthcare and other business processes are the fundamental building blocks of an organisation’s success, information technologies that focus on process management and improvement are good candidates for helping healthcare organisations fulfil their corporate vision. (Anyanwu et al; 2003)

To fulfil the goal of reducing costs and maintaining high quality of care, processes are to be streamlined, automated and reengineered. In corporate business these goals gained much importance during the last two decades. The tool used to fulfil these goals is Workflow Management Systems. (Anyanwu et al; 2003)

There are many Workflow Management Systems that adequately support relatively simple processes. These Workflow Management Systems, while successful in corporate business, fall short in meeting the challenges of mission-critical processes, which are often complex, dynamic, large-scale and QoS-based (Quality of Service). (Anyanwu et al; 2003) These qualities are characteristic for healthcare processes.

1.2 Research Questions

Healthcare processes are very complex and dynamic due to the involvement of both clinical and administrative tasks, large data volumes, and large numbers of patients and all kinds of personnel with different tasks and specific knowledge. Healthcare is a business where many changes occur,

e.g. (new) treatments, drugs, equipment, protocols, legislation. These changes have their influence on the instantiated processes that need adjustment. (Anyanwu et al; 2003)

More and more large-scale patient processes have a span of multiple healthcare organisations and run over long periods of time. This type of process is supposed to require highly scalable workflow systems to support large instances. These large-scale processes often need to be integrated with legacy Information Systems (the different currently used Information Systems by the involved healthcare organisations) and with distributed, autonomous, and heterogeneous computing environments. The expectancy is that WfM can help to support the flow of patient processes. (Georgakopoulos et al; 1995)

The research of this Master thesis was done in the Erasmus MC. The Erasmus MC is the academic hospital of Rotterdam. It has over 1200 beds and a staff of over 10,000 employees. The hospital is classified in 17 clusters and 8 directive boards, further indicated as clusters. The specified field of research is Cluster 12 of the Erasmus MC. The core competences of Cluster 12 are Urology, Women Sicknesses and Obstetrics. These competences are segregated in units. Clinic¹ and out-patients' clinic² divisions are both represented in Cluster 12.

The expectation about WfM stated above, leads towards the central research question of this thesis, which is:

Which contribution can WfM provide to optimise health care in the Erasmus MC?

From this central research question, sub questions have been distilled. These sub questions are of assistance to the central research question. The sub-questions are:

- What is Workflow management?
- How can WfM be supportive to healthcare?
- What are the inefficiencies and bottlenecks of Cluster 12?
- What are possible solutions for the inefficiencies and the bottlenecks?
- What role does ICT have in this solution?
- What is the feasibility of this solution?

Furthermore there are some criteria that apply for optimisation. These criteria needed as criteria for optimisation. These criteria are about: efficiency, effectiveness, and placing the patient in a more central position in the process.

1.3 Methodology

In this paragraph the methodology used for this Master Thesis is set out. The choices made during the research process are also discussed in this paragraph.

Social research can have many purposes. Babbie (2007) distinguishes the three most common, and useful, purposes of social research. The purposes are *explorative*, *descriptive* and

¹ Clinic, where medical intervention and preparation need the patient to be hospitalized.

² Out-patients' clinic, where medical consultations and interventions are done that don't need the patient to be hospitalized.

explanatory. These purposes are very much intertwined with each other. Depending on the research, some of these purposes are more useful than the other.

The research done in this Master thesis mostly resembles the characteristics of an explorative research. The reason for explorative research is that the subject is relatively new and literature about the subject is scarce, especially about the Dutch setting.

Explorative research fulfils three important roles:

1. To satisfy the researcher’s curiosity and desire for better understanding of the defined problem;
2. To test the feasibility of undertaking a more extensive study;
3. To develop the methods to be employed in any subsequent study. (Babbie 2007)

Besides the explorative characteristics of this study, there is also a descriptive part. The purpose of many social scientific studies is to describe situations and events. The researcher makes observations which are then described next. In principle, scientific observations are careful and deliberate, which gives them an accurate and precise nature. (Babbie 2007) The third purpose, explanation, plays a minor role in this thesis. An explanation will give answers on explanatory questions of “why”. Due to the fact of the mainly explorative characteristic of this thesis, the explanation part is difficult or even impossible to achieve at a level that is satisfactory for the researcher and the reader.

The end result of this thesis should therefore be an integrated vision of the contribution of WfM to optimise healthcare within the Erasmus MC. And the feasibility of this vision for Cluster 12. Possible contributions to optimise patient care are discussed. This thesis gives recommendations for improvements in Cluster 12 of the Erasmus MC. Research data is retrieved via two different ways. One was the theoretical aspects from literature. Second, data was retrieved via research in practice. The theory and practice, the conceptualization of the problem, lead to an integrated vision. That vision gives an answer to the research question and holds improvements for the current situation. This vision, of improvements, is reviewed and validated with the practice of Cluster 12 of the Erasmus MC. Therefore the explanation part is not applicable on this research.

This study can also be typified as a cross-sectional study. A cross-sectional study involves observations of a complete population (cross-section) on one moment in time. Exploratory and descriptive studies are often cross-sectional. (Babbie 2007) The study done in Cluster 12 is an observation of one moment in time. This moment in time is the basis for this Master thesis. All remarks and observations must be seen from this perspective.

Getting the information needed for this Master thesis, I attended an internship in the Erasmus MC. Posted at the ICT department (Directie Informatie), where I did my research. Lines with the resources of ICT in the hospital were short and easily accessible. Besides working at the ICT department, I participated in a research team which led the RvN research in Cluster 12. From that angle, pragmatic data about workflow became more accessible. My participation in the RT was mainly research-based, so that the research would be less subjected to “influences”.

1.4 Structure of this thesis

The structure of this thesis is as follows. In the chapter 2, the theoretical domain of this thesis is stated. At first a general view on Workflow Management (WfM) is given. This view is then expanded to WfM in the Health care sector. The chapter is completed with a view of evaluation criteria for successful WfM. These criteria are the bases for this thesis. Chapter 3 focuses on the practice of the Obstetric unit of the Erasmus MC. In this chapter inefficiencies and bottlenecks are discussed. Data is retrieved via observations and a process analysis at the Obstetric unit in Cluster 12. At the end of chapter 3 the main bottlenecks are concluded. In chapter 4 solutions for the concluded bottlenecks are discussed. This is firstly done from the perspective of people and processes. After that the solution from ICT perspective is discussed. In this perspective an architecture is presented as a solution. Chapter 5 discusses the feasibility of the proposals and the architecture mentioned in chapter 4. The theory will be compared with the practice. In chapter 6 the conclusion of this Master thesis is discussed. This is followed by recommendations for further research and a brief discussion. The figure below serves as a reading guide for this Master thesis.

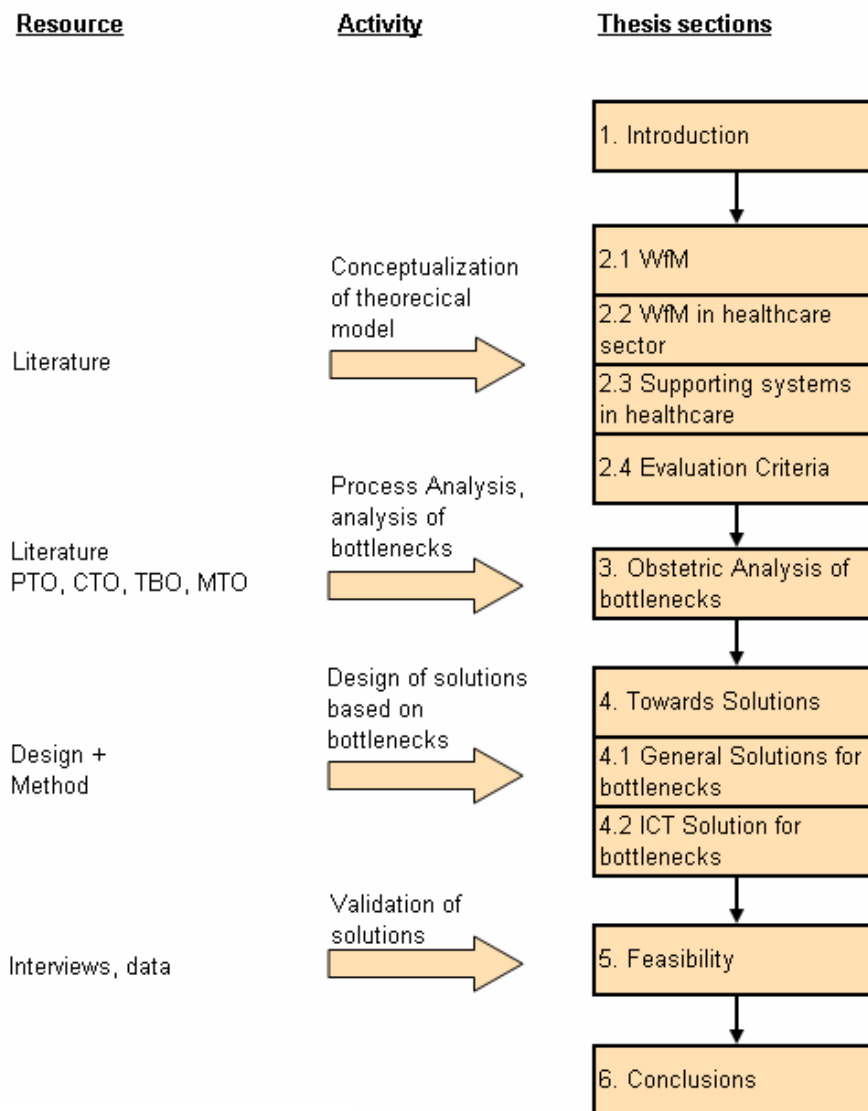

Figure 1: Reading Guide

Chapter 2: Workflow Management

This chapter sets out the theoretical framework that plays a central role in this Master thesis. At first the general concepts of Workflow Management (WfM) will be explored. The second paragraph will focus more on the role of WfM in healthcare services and healthcare in general. The paragraph after that, will discuss WfM systems (WfMS). WfMS supports business processes by taking care of the information logistics of the processes by using ICT. Criteria for the kinds of data that are needed to apply WfMS, are discussed at the end of this chapter. The emphasis of these subjects will be whether these systems are applicable in a general healthcare environment.

When describing workflow management three factors play an important role. These factors are: Processes, People and Technology. (Capgemini 2002) The factors are displayed in figure 2. These factors are very much intertwined with each other, as can be seen in the figure. When tinkering with one of these factors, effects in the other factors can and mostly will be triggered by one another. WfM, for example, can be an enabler for a technical solution. The influence that the process and technology have on each other is emphasised in this chapter. When implementing an ICT application, people and processes have to be adjusted or improved first. When these factors are neglected, the implementation of the ICT project will have little chance for success. (Capgemini 2002) People, or culture, and the work processes have to be altered first, before new technology can have a good fit.

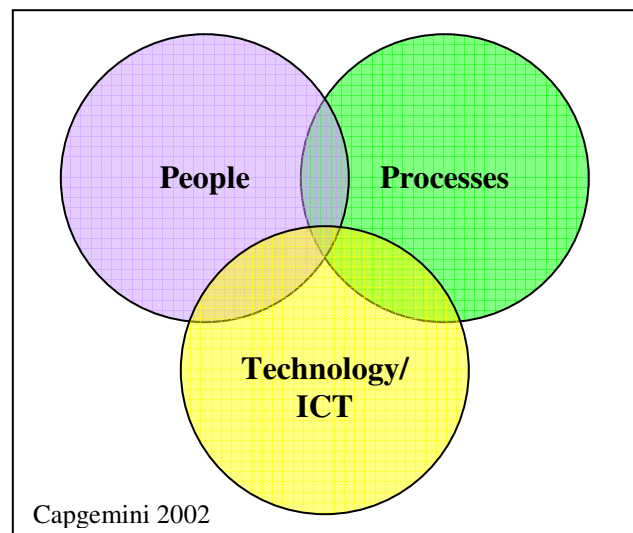

Figure 2: People Processes and Technology

The following paragraph facilitates a broader view on Workflow Management (WfM). Simply said WfM is the control of workflow. The first step is to explain what WfM exactly is, how it is defined in the literature and what central key terms are within WfM. After WfM, workflow processes in general will be discussed. The different aspects of workflow processes will be set out. The next sub-paragraph will describe BPR, Business Process Redesign. BPR is a crucial subject within WfM. This is because it is strongly intertwined with WfM. In the next paragraph improvements on workflow will be summed up. But also how process problems should be foreseen and in what way control of the workflow can be achieved. In the last sub-paragraph workflow criteria are summed up.

2.1 Workflow Management, a theoretical view

Nowadays information can be seen as a very important good. Over the last years information has gained much strength. This is the case for as well as commercial and non-commercial organizations. In modern economies information is often seen as the fourth production factor aside the other traditional production factors, the traditional production factors being raw

materials, capital and labour. (Grefen 2001) Information Communication Technology (ICT) has taken a huge flight in means to cope with ever growing amounts of information. Traditionally the centre of gravity lies in the processing and storage of data and information. Therefore most organisations have funded their ICT around database systems. In the last couple of years notion was growing about whether data processing in complex organizations should not only be based on integrated data management, but also on integrated process management. In an organization the processes usually defines the order and time of data creation and alteration. Structured process management, or in other words workflow management, is an important ingredient for data processing and data management in many cases. Automated support is needed to effectively and efficiently execute process management in complex environments and situations. In general WfM can be seen as administrative logistics. Like physical logistics where the right goods are delivered at the right place and time, WfM takes care of delivering the right information at the right time and the right person. (Grefen 2001)

2.1.1 Workflow management defined

Before defining WfM in this thesis, it is important to have a clear definition of workflow. Workflow is an abstraction of a business process. Normally a workflow comprises a number of logical steps, known as tasks. These tasks consist of dependencies among tasks, routing rules and participants. A task can require human involvement, or it might be executed automatically by ICT applications. (Cardoso et. al. 2004)

There are many definitions about WfM. Frequently used definitions of WfM in literature are summed up below.

Van Der Aalst (1998) says: “The ultimate goal of workflow management is to make sure that the proper activities are executed by the right person at the right time.” Although it is possible to do workflow management without using a workflow management system, most people associate WfM with WfM systems.

Cardoso (2002) defines WfM as a workflow model, which is customized to accommodate specific business process structures. Workflows are design based on business processes. These processes already exist in an organization and need to be improved or managed better. Once the design phase of the model is completed, instances are created to carry the actual steps described in a given workflow. During their execution, the workflow instances can access legacy systems, databases, applications and can interact with users. Workflow systems are flow-independent; the control a data flow among tasks is graphically described during the workflow design phase. This makes applications independent from the underlying workflow system.

Workflow management, according to Georgakopoulos (1995), is a technology supporting the reengineering of business and information processes. WfM involves:

- Defining workflows, e.g., describing those aspects of a process that are relevant to controlling and coordinating the execution of its tasks. It will require the skills of individuals or information systems to perform each task.
- Providing for fast (re)design and (re)implementation of the processes as business needs and information systems change. To effectively support WfM, organizations must evolve their existing computing environments to a new distributed environment that:

- Is component-oriented, i.e. it supports integration and interoperability among loosely coupled components corresponding to Heterogeneous, Autonomous and Distributed (HAD) legacy, current and new systems;
- Supports workflow applications corresponding to business or information process implementations accessing multiple HAD systems;
- Ensures the correctness and reliability of applications in the presence of concurrency and failures;
- Supports the evolution, replacement, and addition of workflow applications and component systems as processes are reengineered.

The definition of WfM used in this Master thesis is an aggregation of the definitions summed up above. The reason for aggregating the definition is to create a better covering definition that suits this thesis more optimal. The aggregated definition comprehends the three factors, people, processes and ICT. The other definitions weren't complete on those factors, and lacked at least one of them. Therefore the aggregated definition is:

WfM is a customization of workflow to accommodate specific business process structures. The goal is that the proper activities are executed by the right person at the right time. Workflows are designed, based on business processes already existing in an organization that need to be improved or managed better. Therefore they support the reengineering of business and information processes. Definitions of process aspects that are relevant are needed for controlling and coordinating the execution of its tasks. This will require the skills and input of individuals and the usage of Information Systems to perform each task. During the execution of tasks, workflow instances support integration and interoperability among loosely coupled components corresponding to Heterogeneous, Autonomous and Distributed (HAD) legacy and new systems. WfM must also be able to access legacy systems, databases, applications and set up an interaction with users. It also must ensure the correctness a reliability of applications in the presence of concurrency and failures. Used applications are independent from the underlying workflow system.

2.1.2 Workflow Processes

A workflow process can be divided into two elements. The first one is the specifications of individual tasks that have to be carried out. The second element is the specification of the order in which the individual tasks have to be done. (Grefen 2001) The tasks are specified as “workflow activities” and the order of the execution of the activities as the “control flow”. When specifying a complex workflow process it is important to gain clear oversight. Oversight can be achieved by specifying the process on more levels of detail via sub-flows. “Sub-flows” are important when using more levels. These sub-flows make it possible to mark a sub-process on a certain level and be developed on the level below. (Grefen 2001) Sub-flow A can be split up in sub-sub-flows. When implementing ICT these sub-sub-flows are necessary to specify functionalities (Cardoso 2002). The sub-flows and sub-sub-flows are illustrated in figure 3.

A “workflow activity” is a part of a business process. It can be seen as an indivisible part within the workflow specification. That means that a workflow activity is the smallest individual part in the process. Typical examples of an activity are: filling in a form, the control of the filled in form, typing a letter. Most of the times one person, without interruption, performs an activity. (Grefen 2001) Factors that are interesting to know within a workflow are bottlenecks within the daily

routine. These bottlenecks can be responsible for the functioning of the workflow. When looking for improvements in a workflow process bottlenecks should be the focus of attention. (Capgemini 2002)

Besides looking at the individual activities in a workflow process, the order of these activities must also be clear. The order of activities is indicated by the term “control flow”. The basic element of a control flow is the sequence, also known as “triggering”. A sequence of two activities shows how the second activity is being executed after completion of the first activity. The first activity triggers the next. (Grefen 2001) A trigger can also be seen as a decision point. When one activity is finished, a decision about beginning the next activity is taken. Within the process, three major aspects can be distinguished. These aspects are actors, roles and resources and will be discussed in the next sub-paragraph.

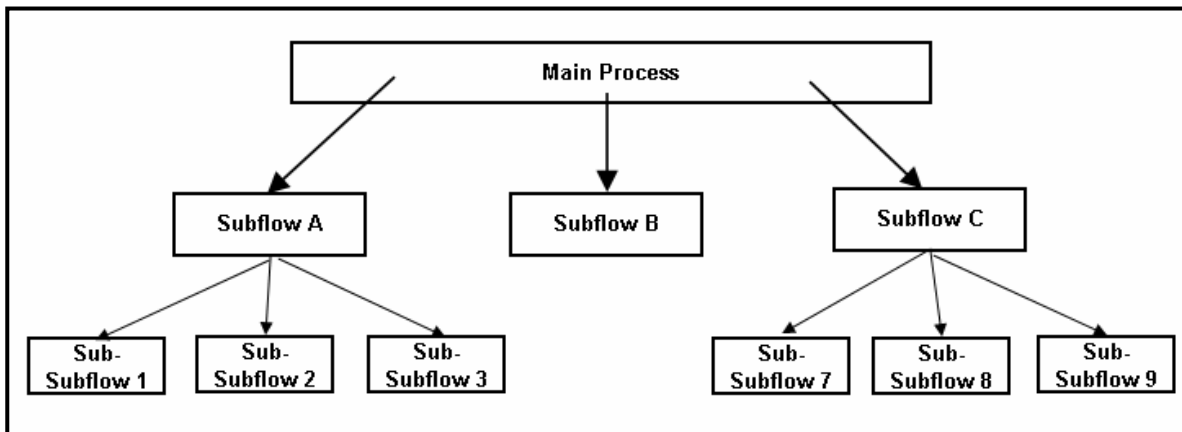

Figure 3, Sub-flows. Grefen 2001

The main process can be split up into subflows or sub-processes. A closer look at the subflows leads to a split up into sub-subflows. This can be done to the smallest individual part of the process.

2.1.3 Workflow processes: Actors, Resources and Roles

As described above, it are persons who mostly handle activities in a process. These persons are the actors within a process. Actors have the following characteristics. Actors have a certain location. The location is the physical place in an organization where an actor is assigned. The availability of an actor states his availability towards the execution of his tasks in a process, e.g. daily activities. An actor also possesses a certain level of competence, specifying his role in the process. Actors can also have references towards other actors with which relations between them can be verified. These relations can play a role in the assigning of tasks to actors by the WfM System, e.g. when replacement of an actor is needed because of an illness. (Grefen 2001) Examples of actors in the health care sector are a nurse, a physician or a financial employee.

In large organizations it usually is not useful to assign tasks to specific individuals. The reason is that it would make the process rigid and complicated. Therefore tasks are usually assigned to groups of persons. Two sorts of groups are possible. The first is the explicit defined group. Random groups can be assigned this way, e.g. all employees that can administer medications to patients. Explicit defined this would be at a level 4 or 5 nurse. The second sort of group is the implicit defined group. The members of this group are described by their common (set of) characteristics. This group of actors is often called a “function group”. This is because the people

in this group often have the same function. (Grefen 2001) A function group e.g. could be a physician assistant.

As stated above, WfM is focussed on the support of business and information processes. In the business process production resources carry out activities. In an administrative environment, resources often resemble office employees. Other examples of resources are, a hospital bed, the availability of the operating room, a printer or an assembly robot. The basic characteristics of a resource are that a resource:

- Can execute certain tasks;
- Is uniquely identifiable; and
- Possesses a certain amount of capacity.

It does not mean that resources can only have one activity, but the capability has limits. Resources are often classified in the same resource-groups, like the classification which is applied to create function-groups. A resource class that is based on the functional characteristics of the resource, is called a role. A role is a collection of resources that have a couple of specific skills. A physician, administrator, hospital bed, secretary are examples of roles. On a higher level, resources can also be classified on their place within the organization. Then they are based on their organizational characteristics. (Van Aalst & Van Hee 1997)

Within a process, the participating actors or groups have their own specific role. A role is the description of actors whom have a specific task and posses the specified/distinguished rights to perform that certain task. During the execution of the workflow the role will be determined dynamically, on basis of a description of the role, so the required actors are commended for the task. (Grefen 2001)

2.1.4 BPR

Very often WfM is spoken of in the same context as Business Process Redesign (BPR). BPR is the redesign of (mostly administrative) processes in an organization. The main goals of BPR are gaining efficiency and or effectively improve the processes within an organization. Most of the times BPR is not limited to only one process. BPR looks at the coherence of a couple of processes that encapsulate the whole process from the beginning till the end. Only then it will be possible to reach a thorough redesign. (Van Aalst & Van Hee 1997) In a dynamic environment, companies can have a continuous process improvement when applying BPR. This way they have a powerful tool to react on changes that occur in the environment. Example results of improved redesign processes are the reduction of waiting times, better workload dividing, (pre-emptive) removal of excess process steps or specific designed process pathways. The changes that come with BPR can be very humble. But on the other hand process improvements can have a large impact. (Grefen 2001) BPR is not always necessary. Improvement of processes can also be gained by adjusting them. This is a less rigorous solution. Organizations will often first look if adjustments of the processes will be sufficient before turning to BPR.

In short WfM systems can be seen as an “enabling technology” for BPR or process adjustment. In practice this relation is often even more complex. The introduction of WfM can be used as a key enabler to begin with BPR. (Kang et al 1999) On the other hand BPR can be used as an “excuse” for the implementation of new technologies. The relation between these two is important to keep in mind and have a clear vision on. (Grefen 2001)

When beginning with BPR or process adjustment, it requires processes to be well described. After this description the development of the new process or adjustment can begin. ICT implementations are taken in consideration after BPR or process adjustments. The chances for success are much bigger this way. (Capgemini 2002)

2.1.5 Improvement of Workflows

The necessity of improvements in processes has already been discussed in this chapter. One of the main questions of improvements, is “when” does the reason for an organization occur to adapt or improve a process. There are a couple of symptoms that can be seen if a workflow isn’t working properly. These typical symptoms in the workflow indicate sticking points that causes to fail optimal functioning of the organization. Typical symptoms are:

- A (too) large quantity of cases that are still in progress.
The large quantity of cases can be caused by big fluctuations in the supply of the demand side. But it can also be caused by a lack of flexibility of the usage and deployment of resources. Another possible explanation can be that the process contains too much steps that have to be followed sequentially.
- A (too) long walkthrough time in comparison with the actual treatment time.
When the actual treatment time is only a small percentage of the total walkthrough time, there is a lot of potential to shorten the walkthrough time of the process.
- A (too) low level of service
The level of service of a workflow is the degree in which an organisation can settle a case within a certain amount of time. When walkthrough times fluctuate, the level of service is usually very low. Guaranties about a walkthrough time can’t be given.
When people in a process have to say “no” a lot, then the level of service is also very low.
The potential risk is that the customer takes his business to the competition.

These are the most important symptoms. It is not a good idea to find a short-term solution to keep head of these problems. This results in fighting the symptoms. At this point the causes of the symptoms must be retrieved and an action plan must be developed. (Van Aalst & Van Hee 1997) These improvements can be very small, but something more radical such as a BPR is also possible.

Problems in workflows have to be identified as early as possible, otherwise they grow bigger and will be more difficult to repair. This can be done by monitoring measurements of the performance within the workflow. The measurement will take place via performance-indicators which can be done by using, available, Business Intelligence. A performance-indicator is a numerical measurement that is used to express the performance of a certain aspect or activity. Performance-indicators can be distinguished into two groups, external and internal performance-indicators. The external performance-indicators focus on the performance that is important for the surroundings of the workflow, the case. E.g. the index number for the walkthrough time or the reliability of the walkthrough time. These index numbers can be split up to the specific properties of the case. The internal performance-indicators are focussed on the index number of resources which indicates the amount of effort that is needed to realise the external performance. Examples are the occupancy of the resources, the number of cases per resource and the rate of circulation. A bad external performance means loss of money. When a hospital has a too long walkthrough time for e.g. an eye surgery, the patients will go to competing hospitals where their treatment is shorter

or e.g. where the whole treatment takes place just one day. The internal and external performance activities are hence intertwined with each other. A change in one activity will have its effects on another. But in most cases it is possible to improve the external performance of a workflow without integrating extra resources. These kinds of improvements can be reached by redesigning the workflow. (Van Aalst & Van Hee 1997)

2.2 Workflow Management in Health care

The healthcare sector, in the Netherlands, is very different in comparison to the business sector. Both of them are multi actor based. But the actors in the health care are structured on their professional autonomous basis of the actor. In the healthcare sector autonomous parties, which all have their own vision, exist aside each other in the same organization. The actor groups that can be defined are: the physician, the nurse, the patient and the administrative employee. The Government is not included in this list of actors. The illustrated four actors are all very much involved in direct patient care, or are the subject of patient care. The Government, in that extend, is not. Within this thesis the Government will therefore not be involved. This choice was made to narrow down the framework of this thesis. The four actors do all have different interests and views towards patient care. Due to their different interest and views, they have different ideas on how to improve healthcare. They all have their own influences on the development of healthcare, and therefore also have an opinion on WfM in healthcare. In the following chapters of this thesis, these actors will be taken into consideration.

This paragraph will discuss Workflow Management initiatives in health care. This paragraph will narrow the framework for WfM in the health care. At first clinical pathways are discussed. The clinical pathways are followed by standardisation in healthcare. These subjects have a strong link with each other. The last subject is Order Management. The multiple actors are not involved, due to the more theoretical character of this paragraph.

2.2.1 Clinical Pathways

A clinical pathway (in Dutch “zorgpad”) is the care process which a patient goes through during a sickness. It starts with a health complaint and ends after the patient is treated for the health complaint. A Clinical pathway displays all the care activities of the treatment that a patient has to follow. Care activities are organized around the patient. This must reduce inter-doctor variation, minimize delays in a treatment and decrease resource use. (Lin 2000) A clinical pathway coordinates the treatment procedure and also defines the quality of care that is provided at each activity. (Smagghe et.al. 2005). The main goal of a clinical pathway is to improve the quality of care while costs are decreased.

The goal of clinical pathways is to organize the care activities around the patient. It provides the corresponding ideal sequence and timing of physician and staff actions to achieve the predefined goals with optimal efficiency. (Pearson et al 1995) Reasons to use clinical pathways are thus mostly about improving the quality of care and/or reducing costs of a certain product of service.

Strongly related is the timely execution of the treatment within the clinical pathway. Implementation of clinical pathways can be difficult for the following reasons:

- A great deal of time, skill and effort is needed to find and analyse the highest quality evidence available. This quality is essential when making clinical pathways.

- Medical knowledge is changing on a continuous basis. Therefore clinical pathways should also be improved continuously, to be certain that the highest quality is obtained.
- A clinical pathway cannot have all the answers on individual cases.
- Implementation of clinical pathways can face organizational and/or cultural challenges. For example the resistance from physicians against standardisation of medical work. (Smagghe et.al 2005)

When looking at Clinical Pathways, standardisation of healthcare is a sensitive subject. Many people have an opinion towards the subject. In the next paragraph a closer look on the impact and possibilities of standardisation in healthcare is set out.

2.2.2 Standardisation in health care

Healthcare work is a social process. It involves simultaneously dealing with sick individuals, each of which has its own problems and needs, and is connected with other physicians and organizational units. Because of the nature of healthcare work, standard organizational solutions never wholly fit the individual needs of a patient. Sometimes standard solutions aren't available when they would be appropriate. Healthcare workers are therefore constantly compromising between the problem and solution to give the best care to the patient. (Berg et al. 2003)

Standardisation of healthcare pathways could provide a possible solution for giving better suited healthcare for the patient. When talking about standardization in healthcare, there is much resistance. The medical profession and the medical sociologists are emphasising the unpredictability of healthcare, and that standardisation should be viewed with great care. In the research of Strauss et. al. (1997) criticism about standardisation of patient care is put forward. The criticism comprehends that disturbance of the pathway of the patient is imminent and occurs often. The claim is that this is caused by the unpredictability of the sickness course of the patient. This could be the result of bad cooperation between different functions, faulty technology, etc. Hence the criticism that healthcare work is very difficult to standardize.

More criticism includes the fact that multiple patient care pathways exist among another, causing continuous adaptation of the pathways itself, leads to competition for (limited) resources. The lack of clarified success criteria of a pathway, can lead to a dispute of the next steps that have to be taken. Another argument is that the behaviour and preferences of the patient can't be planned because change can occur during the whole pathway. (Bal & Bont 2005) Research has shown that 80% of the care needed by the patient can be standardized. This makes a strong case for applying clinical pathways.

Standardisation, e.g. by using clinical pathways, also has a couple of advantages. Without clinical pathways inefficiencies can exist more easily. The inefficiencies are most due lack of coordination. Coordination is needed to get the patient from one care activity to another. When there is little coordination the care activities have to be planned over more times to get a good fit. If not, time loss will occur. The time loss affects the physician, investing time in making new appointments. The patient is affected as well, because of long waiting times. A known inefficiency is the planning and waiting for a CT-scan after a first consult by the physician. (Bal & Bont 2005)

The advantage of a clinical pathway overview is the possibility to plan care activities in advance. Most appointments in healthcare are dependent of previous care activities or appointments and of available capacity at other locations within the organization, e.g. an x-ray is needed before the first consult with a physician. The description of the steps within the process helps to make the

pathway mutual dependency insightful and offers a better planning. Criteria for quality can also be fixed within the clinical pathway. (Bal & Bont 2005)

When talking about planning up-following care activities in a clinical pathway, it is interesting to take a closer look at Order Management. In the next paragraph Order Management will be outlined within the context of Clinical Pathways.

2.2.3 Order Management

Order Management (OM) is not about replacing paper forms for electronic versions. OM is about the facilitation of health care workers for initiating and protection of the total sum of health care activities which incorporate the treatment of the patient. OM is the electronic guarding of the healthcare pathway.

The goal of OM is:

- Providing quality on a consistent level
 - supporting working on a basis of protocols, standardisation.
 - Input control and decision support.
- The realisation of time reduction
 - during the application and execution of applications.
 - monitoring the progress of the clinical path.

Examples where OM would prosper are on the area of: medication, radiology, the operating theatre, laboratory, nursing activities, and transport requests. These aspects should always be taken in account when setting up an OM system. (Reingoud 2006)

Functionalities of OM are:

- Monitoring of individual activities in the clinical pathway
 - Giving oversight of individual activities within the clinical pathway
 - Giving oversight in time, for planning purposes
 - Identifying status change and deviations of the predefined norms
 - On clinical paths based access for (lab)results and reports
- Order application
- Order planning
- Order execution
- General oversight
- Placing and interfacing the information in the Electronic Patient Record. (Reingoud 2006)

Order execution comprehends the, administrative, status of the patient in the pathway.

For a patient to be treated effectively treated in a clinical pathway, integration of processes is a key aspect for success. This change can only be achieved when changes in the organisational structures are met. This process includes registering a planned activity (electronically) and the activity being requested, planning of the activity’s execution, returning the status of the activity, giving feedback on the activity. Across all of these steps, having the data available electronically can provide opportunities for monitoring of the process.

Figure 4 shows the Order Management process.

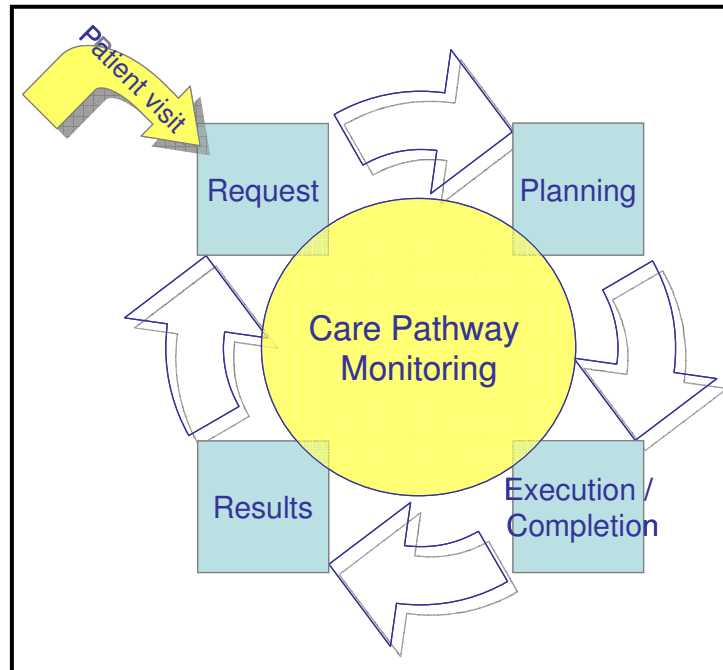

Figure 4: The Order management Process

When a patient has an appointment with the physician the physician sends out a request, e.g. a blood test. This request is planned in time with needed resources such as personnel. When the execution of the request takes place the physician who gave the order gets a notification. The next step is that results are returned to the physician and choices about further care activities can be taken.

2.3 Supporting systems in Health care

2.3.1 Workflow Management Systems

The organisation within companies is getting more and more complicated to organize. This is one of the reasons that (automated) information systems were developed to support the control of the processes and their mutual harmonization. (Van Aalst & Van Hee 1997) Highly scalable workflow systems are needed to support large instances and multi actor based organisations. Automated processes also need to be integrated with legacy information systems (the different currently used IS by the involved healthcare organisations) and with heterogeneous, autonomous and distributed (HAD) computing environments (Georgakopoulos et al; 1995). Hence Workflow Management systems (WfMS) were developed.

WfMS is the technical part or the development of Workflow Management. (Grefen 2001) WfMS supports business processes by automating the information logistics of the processes. This means that WfMSs are concerned with delivering the right information on the right time at the right person within the right computer application. Much of an enterprise's infrastructure and organization is enabled by IS that directly or indirectly supports business processes of crucial importance to growth and survival. By managing these processes more efficiently, competitive advantage can be gained via cost reduction, product enhancement, and customer service improvements. (Cardoso et al 2004) A WfMS does not execute any tasks of a process. WfMS is a piece of generic software and is applicable in many situations. (Van Aalst & Van Hee 1997)

WfMSs are based on the concept of a workflow. They provide a workflow model that is customized to accommodate specific business process structures. Workflows are designed based on business processes, already existing in an organization, that need to be improved or managed better. Instances are created during the design phase of the workflow. During their execution, the workflow instances can access legacy systems, databases, applications, and can interact with users. Workflow systems are flow-independent. The control and data flow among tasks is graphically described during the workflow design phase. This makes applications independent from the underlying workflow system. (Cardoso et al 2004)

A WfMS reads, automates, processes, and manages workflows by coordinating the sharing and routing of information. During processing, tasks, information, and documents are passed from one participant to another in a way that is governed according to a set of rules, routes and roles. The automation of work items increases process efficiency. Furthermore, the management and analysis of workflow instances provides an opportunity for measuring parameters of business processes in order that continuous improvements can be made. (Cardoso et al 2004)

WfMS, just like Database management Systems (DBMS), have a wide “horizontal” function. Application Systems (AS) have specific “vertical” functions. The AS can also be interactive. (Grefen 2001) In figure 5, the infrastructure of a WfMS is displayed. AS can also be interactive. In figure 4 AS 1, 2 and 4 are interactive and require input from the user. AS 3 on the other hand, works automatically. Depending on the function of the AS, a coupling with the DBMS and/or the WfMS is made.

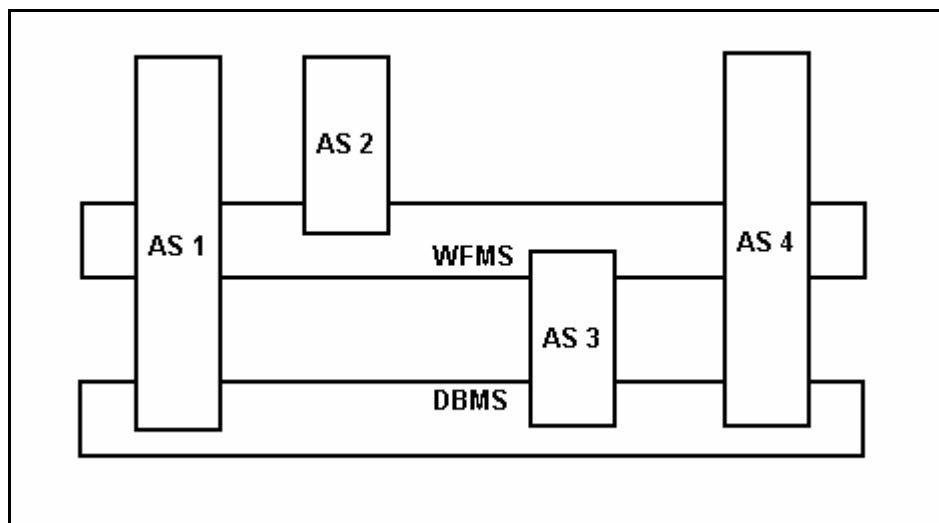

Figure 5, Infrastructure of WfMS and application systems (Grefen 2001)

Application Systems (AS) 1, 2 and 4 are operated manually for input and output. Data is transferred via the WfMS. The function of AS 1 and 4 require a coupling of the WfMS with the DBMS. AS 3 works automatically, hence it won't stick out above the WfMS.

Workflow technology also allows for the integration of previously separate communication, information, and data flows into a working process at any time, while accommodating unpredictable complexity. At the same time, workflow technology is an environment that supports the integration of previously separate information systems, such as office information systems, electronic data processing, telecommunication networks. Cardoso (2004) writes about

the three types of applications which WfMS technology focuses its attentions and effort on. These types are:

1. Workflows involving humans
2. Workflows involving systems and applications
3. Transactional workflows.

The first type involves humans who collaborate, and who are coordinated when performing tasks. The control and coordination of human tasks is done by the WfMS. Settings like these increase the complexity of WfMS implementations; responsibilities have to be shared to ensure consistency of documents and workflow data among its users. In the second type, WfMS implementations are responsible for the control, coordination, and execution of computation-intensive operations and specialized software tasks without human intervention. Access to HAD information systems, e.g. relations databases, web servers, may be required. And it needs presenting a good means of integrating applications that cannot be rewritten. The third type involves human interventions and system orientation on a transactional-based level. In such systems the coordinated execution of multiple tasks that may involve humans, requires access to HAD systems. It also has to support the selective use of transactional properties, e.g. consistency, for individual tasks or for entire workflows. Sophisticated techniques such as concurrency control and recovery techniques in order to ensure the consistency and reliability of the system are needed for support. (Cardoso et al 2004)

2.3.2 Criteria for successful WfMS

At this moment healthcare organisations are focussing more on the existing processes. Klischewski and Wetzel (2001) proclaim a couple of sticking points that exist in the healthcare environment concerning the processes. The first point is the lack of overall responsibility for either the process or it's planning. The process mostly relies on the ability and commitment of individual providers to flexibly shape the service according to their special insights about the patient's case. (Klischewski & Wetzel, 2001) A lack of fixed responsibilities seem to be the crux of this problem. Secondly there is a problem relating to the exchange of documents. Clear rules are needed for documentation of patient records and the exchange of documents in the process. The third point concerns the monitoring of the process status. The healthcare providers involved have low awareness about the complete figure of the process, its current status or further development. The healthcare providers often lack information about deviations from tacitly assumed ways to proceed, or are unable to obtain this knowledge. (Klischewski & Wetzel, 2001)

These identified sticking points by Klischewski and Wetzel result in a set of requirements regarding the software support for inter-organizational services in healthcare, or in other words Workflow Management. They claim four main requirements for the design process.

- *Flexibility support*
The support of the process has to provide flexibility and dynamic selection and configuration of services as the process moves on. The steps in the process also need to be transparent to the parties involved.
- *Interoperability*
Information between different physicians and other healthcare providers must be exchangeable and shareable. Software components must be compatible with each other.
- *Customer Orientation*

Service delivery has to consider the possibly changing customer concern and the subtleties in customer satisfaction. This goes beyond efficiency criteria of underlying processes and has to do with understanding the customer concern and with service customization, e.g. the availability of services.

- *Agreement Process*

The parties involved have to formulate the entire service process, e.g. the kind of service delivery, ICT support. (Klischewski & Wetzel, 2002)

These requirements are directly related to financial aspects, which also have an important role in healthcare.

Other than the requirements that are described above, Grefen (2001) defines an additional set of criteria for WfMSs. His criteria set out what kind of data is needed to develop and create a WfMS. Grefen defined the following criteria:

- *Process Specification*

The process specification contains a detailed description of the workflow process. By saving this specification in a database, elements within the specification become accessible.

- *Organization Specification*

The specification of the organization contains the description in which the workflows have to be executed. In this organization model descriptions of actors, functions, groups etc. are written.

- *Information Specification*

The structures of information which are manipulated by workflows according to the information model of the WfMS are described in this point.

- *Situations in Current Cases*

The situation on “current” cases contain relevant situation and context information for the execution of every case.

- *Historical Information*

Is the information of cases of which the implementation is completed. This information is merely used within the function of an archive. This information can also be aggregated.

These criteria should be used as a guidance principle when developing and arranging WfMSs.

2.4 Conceptualization

This paragraph describes the conceptualization for the rest of this thesis.

When discussing workflows, criteria are needed to find out if a workflow should be revised. There are symptoms that designate problems of the function of a workflow. These symptoms were a (too) large quantity of cases still in progress, a (too) long walkthrough time in comparison with the actual treatment and a (too) low level of service. (Van Aalst & Van Hee 1997) These symptoms are of a general nature. The basis of these problems can be found in other factors. For example poor quality isn't always easy to see. Other researches and supplement criteria points are needed to scrutinize the workflow in a better and structured way.

In figure 6 the conceptualization, which is used in this thesis, is stated. The conceptualization is combined with the people, process and ICT model of Capgemini. The unknown aspects have to be scrutinized to fill in questions about the actors, the business process and ICT. The questions

are concluded from the requirements described in the previous section. These requirements are integrated in this conceptualization.

Questions for the *business process* are:

- defining the activities on a current and a historical level
- specifying the process

The questions for the *actors* are:

- the identification of actors
- the identification of the location of actors
- what are the responsibilities of the actors
- the organization specification

Questions for ICT are:

- the identification of used systems
- the information specification (what information is needed at what activity)

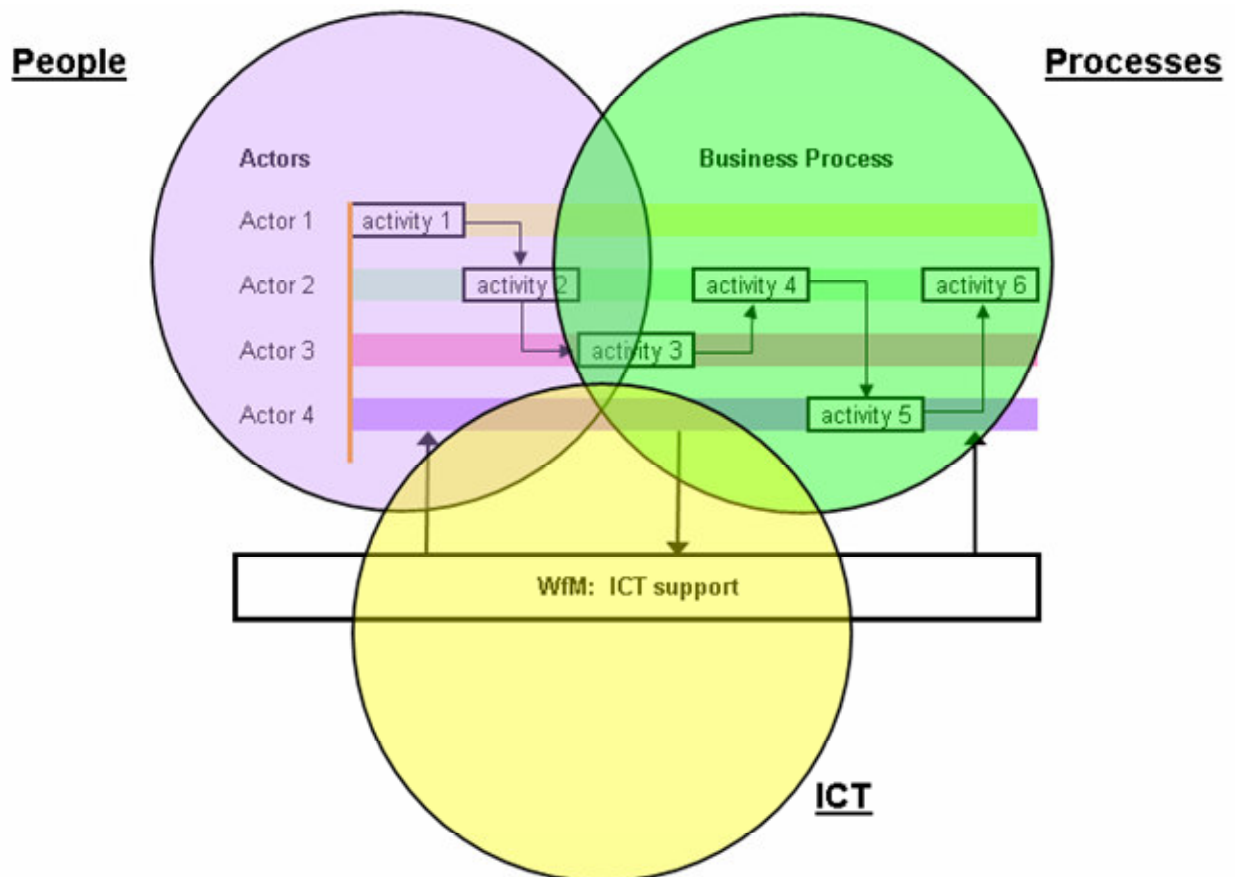

Figure 6: Conceptualization Model

The Capgemini model is integrated in the conceptualization.

Criteria for operational aspects are also needed. They specify criteria for WfM that describe the process. These criteria are: routing work objects, assigning tasks to actors (employees) in office processes, task planning in time, monitoring the process progress, settling exception situations, generating tactical and strategic management information.

At last there are some additional requirements for WfM which are also needed for the design of the process. These additional requirements are:

- Flexibility support
- Patient information must be sharable
- Software components must be able to communicate with each other
- The level of service must be high
- Agreement of different actors is necessary

The next chapter takes a look at the Obstetric unit of the Erasmus MC. Practical analysis will be discussed there.

Chapter 3: Analysis of the Obstetric unit

In this chapter the analysis of the unit of Obstetrics is set out. Remarkable results of the DMO researches are also presented. The case of obstetrics is described by the process analysis. It takes a closer look at the path a pregnant patient takes in the Erasmus MC. First of all is to find out where the bottlenecks are. The goal is to retrieve points of improvement within the process.

This chapter is build up as follows. In the methodology of chapter 1, the project “Ruimte voor Nieuw” (RvN) is briefly discussed. In paragraph 3.1.1 the project is enlightened from a more detailed look in the practice of the Erasmus MC and in particular Cluster 12. In section 3.1.2 the most essential results from the DMO researches are presented.

In paragraph 3.2 the process analysis is discussed. The goals of the process analysis were as follows:

- The identification of core processes and activities which are split up to primary and supporting processes.
- Getting insight in the bottlenecks, logistic performances, quality and efficiency ideas from a logistic point of view.

The analysis of critical points led to a further scrutiny towards administrative processes. In paragraph 3.3.2 the accumulated results of the Process Analysis are stated. The bottlenecks and sticky points of Obstetrics are set out. In section 3.3 the main bottlenecks of the obstetric unit are concluded.

3.1.1 Efficiency Researches within Cluster 12

In this paragraph the efficiency researches (DMO) of the “Ruimte voor Nieuw” (RvN) project are summed up. The variety of these researches shows the vastness of the DMO in general. Details and the basis of the actions about the RvN project in Cluster 12 are set out in appendix 1.

The DMO researches are the:

- Patient satisfaction research (PTO, from the Dutch “Patient tevredenheidsonderzoek”);
- Client satisfaction Research (CTO, from the Dutch “Client Tevredenheidsonderzoek”);
- Employee satisfaction research (MTO, from the Dutch “Medewerker Tevredenheidsonderzoek”);
- Business Information, called Management Information in healthcare;
- Process analysis; and
- Time spending research (TBO, from the Dutch “Tijdsbestedingsonderzoek”)

The goal of the satisfaction researches is to find out the satisfaction towards the way work is done. The PTO scrutinizes whether the patients are content about the care treatment they receive from the different actors. The CTO asks whether clients, people who take a service from the unit e.g. consulting a pediatrician for a newborn baby, are pleased about their relation with the unit in question. In the MTO the employee is asked about the joy of working in their unit. Questions asked in the MTO are about the amount of stress and workload that is experienced, for example. The satisfaction researches should give a look in the experienced joy and (work) expectations of the research groups. By improving the satisfaction, efficiency is also gained.

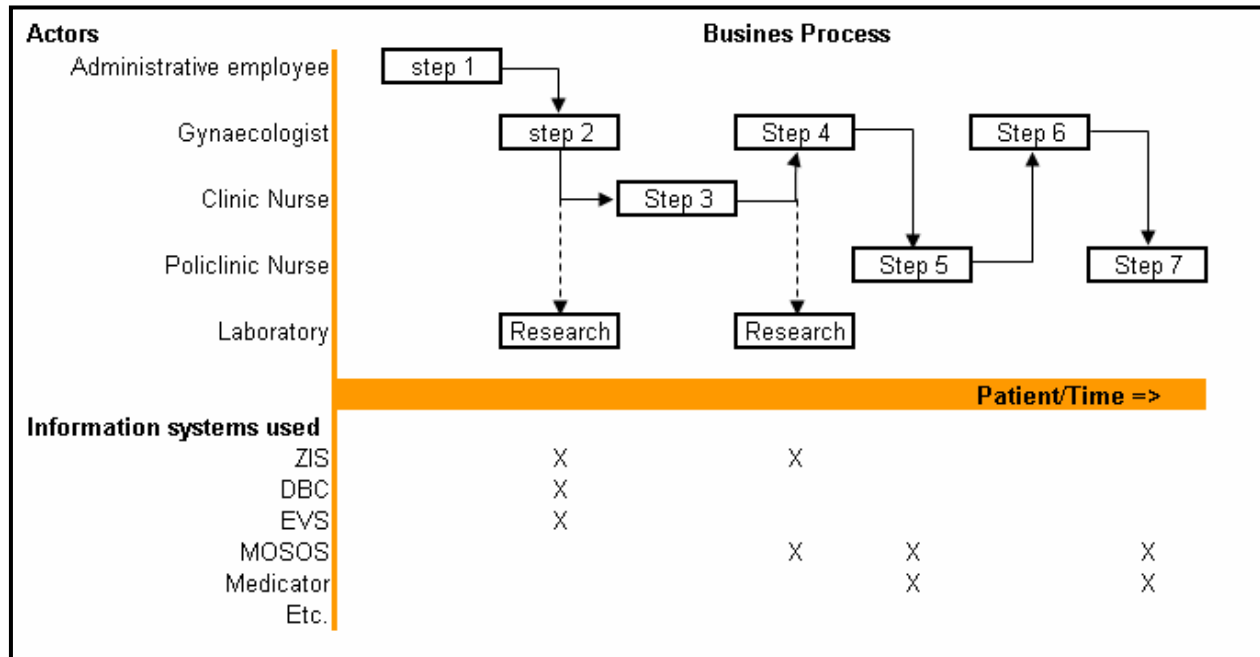

Figure 7: Process in Multi actor environment

A lot of different actors are involved in the different activities of the process. This increases the complexity of pinpointing bottlenecks.

The process analysis gives insight in existing bottlenecks and bottlenecks that are present in Cluster 12. It will also show the workflows that exist in the Cluster and the units. For the project and this thesis, pinpointing bottlenecks is of great relevance.

Figure 7 shows the complexity of pinpointing bottleneck in a multi actor environment. This model shows a simple version of the process. From this model the necessity of the variation of other DMO researches to retrieve valuable information is also stated. The “intertwined” results of the DMO researches are the resources for the distillation of bottlenecks. Existing bottlenecks can also be an enabler for other additional researches to gain better insight in the proclaimed inefficiencies.

The example on the next page in the text box, shows how de different DMO researches are intertwined with each other.

The model in textbox 1 and the example stated in the text compartment shows the importance and impact of the other researches on the bottlenecks in the workflow. The results can strengthen each other in such a way a bottleneck can be found more easily.

In this thesis the process analysis is very important. The reason for that is that it narrows down the focus on the workflow. Less relevant discussions about other influencing factors, that have a certain role and impact are avoided. But before we take a look at the process analysis, some results of the DMO research are discussed in the next paragraph.

A unit in the Erasmus MC believes that they work with an under capacity during the morning hours. The people who work on the unit are easily agitated. The MTO (employee satisfaction research) confirms that employees experience a lot of stress in the morning hours. The PTO (patient satisfaction research) shows that the patients experience low service and are not treated nicely when they arrive at the consulting hours in the morning. By coupling these two outcomes, a focused scrutiny for the cause of the experienced problems can be done more easily. The cause was found by scrutinizing the TBO results. In this case the conclusion was that the patient transfer and the start of the morning consulting hours had an overlapping time slot. This overlap caused stress with the employees who pointed their frustrations towards the arriving patients. The solution for this particular bottleneck was to start the consulting hours a half hour later. As a result the employees experienced much less stress, and the patient treated in a more humane way.

Textbox 1: Example intertwined ness DMO researches

3.1.2 Results from the DMO research

This paragraph sets out the some essential results which were directly retrieved from the DMO researches from the Obstetric unit. These results will give a sketch of the unit of obstetrics. The process analysis will not be included in this paragraph.

The results of the CTO weren't very good. All the results were below the minimum level according to the predefined values. The clients of obstetrics are referrers such as gynaecologists and obstetricians from other nearby hospitals. They were very dissatisfied with the communication of the unit. Patient letters, about treatments done and/or after a patient gets fired from the hospital, aren't always received in time by the referrers. Another point is the perceived contact from the nurse with the patient. The contact with patients scores very low in the CTO. This outcome was received as a surprise by the unit. The referrers mostly don't visit the unit and therefore have a small base for their comment and opinions about the way the nurses contact the patients.

This remark, on the contact with patients, leads us to the patient satisfaction research (the PTO). The image that patients have is quite different from the referrers. The outcomes of the PTO were excellent. The activities done by the nurses and the gynaecologists were scored very high by patients. The treatment and care delivered by the nurses also scored very high. In contrast with the score of the referrers, this is very remarkable. Perhaps the nurses are more focussed on giving good care to the patients, instead of pleasing the referrers.

The results of the MTO, the satisfaction of the employees, on the other hand was far not good. Employees are very dissatisfied on topics like help received from their supervisor, workplace boundaries and role conflicts. It appeared that nurses regularly get contradictory orders, which are received as a as a negative aspect to fulfil in their role. Workplace boundaries are experienced as a negative influence on their joy in work. This means that their work does not allow them to get a cup of coffee or have a chat with a colleague. Another negative point is the help received from their supervisor. Problems, work of personal related, aren't good discussable with the supervisor and therefore support can't be given. Positive points on the other hand are the security for the future and very little psychic complaints. The nurses believe that they can keep their job for the next five years and they also expect to make a promotion. These beliefs have a very positive

influence on experienced stress factors. Experienced psychic complaints are low due to the peacefulness and regularity character of their work.

Vitality of the unit, the rate of preparedness to change, is very large. A large vitality means that a lot of people are prepared and willing to change for the better. On most of the questioned topics, scores are very high indicating the willingness to change. One point that scores below average is the available means or money available within the unit and Cluster. Results from other units and Clusters on the available means are more or less the same. This indicates that the available means in the hospital are experienced as a scarcity.

The TBO research brought back a lot of data. In appendix 2 the methodology of the TBO is explained and in appendix 3 an example of a TBO outcome is displayed. As can be seen, analysing such a graph isn't very simple. Additional knowledge of the unit is necessary to draw conclusions. These conclusions can also result in more questions for the nurses on the unit for verification. These questions were asked during feed back sessions with the target group to get more useful information.

One of the things that can be noticed is the peak in the morning between 7 and 12 o'clock. Observations made clear that the nurses were very busy in the morning, making up the beds, giving physical care to the patient, preparing medications etc. During the morning hours, the time spent on making CTG's (Cardio Toco Graphy) is rather much in comparison to the rest of the day. The reason is that CTG's must be done before the visiting round of the gynaecologists begins. They need to have the most recent information about the patient and her baby. Around 11 o'clock the nurses are finished with their morning tasks. Very tired they plunge down in the coffee room for their break. In the afternoon most of the administration is done. At that moment patients are resting and other tasks physical patient care can't be done.

The transfer of patients also takes a fair amount of time. It takes about half an hour, three times a day. In the transfer of the patients most nurses are participating.

Besides the DMO researches, observations were also made. They were made during the occasional visits, further questioning during visits and during feed back sessions. One of the first things noticed doing pre-research, is that there were little documents about the processes within the unit. Agreements made on obstetrics, mostly aren't documented. The danger of not documenting processes and agreements, is that development in the unit isn't controlled. This brings a risk that the ambiguity of processes grows in time. Activities are handled in a way because "that's the way it works around here".

The culture about asking questions to your colleagues is very remarkable. Asking questions to each other isn't done. Nurses rather don't ask someone a question to their colleagues. They think they should know the answer themselves and don't want to look stupid.

Observations of other supporting units, such as the ICT-department, were also made. These observations are about the process of how ICT is implemented in units within the Erasmus MC. One of the systems used at the obstetrics unit, for example, is the Electronic Obstetric System (EOS). This system was replaced by the Electronic Obstetric Record (EOR). The new system implies that it's a more comprehensive Record with more functionalities. But the new EOR is actually just a slightly improved version of the EOS. It solved little of the existing problems that are present.

Questions about why this new EOR is implemented arise. Also because the system was bought four years before implementation. It appeared that the system wasn't implemented at that time because the program wasn't working according to the wishes of the obstetrics unit. After altering the software, which took the ICT-department two years, it was ready for implementation at the obstetric unit. But at that point another system had primacy to be implemented. That other system interfered in the functioning of the EOR. Therefore it had to be altered again. This was the primary reason why the process took so long. The decision for the implementation of the EOR was made by the obstetrics unit. Their wishes were stated towards the ICT department. At the ICT department the technicians execute the wishes received. Their task is purely technical. Therefore they will not execute a scrutiny of the unit in question, such as analysing the processes of the unit. That task should be done by someone else. The same thing is said by the management of the obstetric unit. As a result the processes aren't analysed properly. Other aspects share the same faith. The fact if redundancy could occur by implementing new systems, isn't researched at all.

In the next paragraph the process analysis of obstetrics is discussed. First the methodology of the case study of the unit is described, followed by the case study itself. Finally the results of the process analysis are discussed.

3.2 Process Analysis

3.2.1 General methodology

The process analysis is divided in three phases. The first phase is preparing the research. In the second phase the measurements and analysis take place. Third the potential for improvement is established. For this thesis the second phase will have the most emphasis in this chapter. The third phase will be discussed further in chapter 4.

When preparing for a process analysis, a focus of the existing processes was needed. The reason for making a focus is to prevent stranding in details and also due to a limited amount of available time. From the global view of an organizational component, a selection was made. The selection is based upon preliminary research of documents and from signals given by people. That way the field of research gets more manageable. In this manageable field a selection in the primary and supporting processes was made. Processes with one of the following criteria are preferred. The selection is based on a:

- great number of patients;
- long walkthrough times;
- complaints or signals that the quality is below standards;
- large inter doctor or inter nurse variation;
- “complex” process due to e.g. multidisciplinary units.

The concentration of the research is thus focused on the bottlenecks that cover larger areas of research. The purpose is to get the most efficiency with the same amount of effort. Therefore gaining an optimal efficiency with the available capacity. The bigger the potential efficiency, the bigger the gain will be. Big wins generate more revenue and are necessary to reach the 10 percent efficiency that is needed.

The second phase is the measurement and analysis of the processes. This goal of this phase is to get a more focused look on certain aspects of the process. As described above, a more manageable and structured focus on the global process view is needed. The aim is to focus on the bottlenecks. There are several methods, used by the RvN project, to get a focus on the bottlenecks. These methods are the saw tooth method³, the bottleneck analysis, a brown paper session and indicators of health care processes.

A sticking point analysis is aimed only at the bottlenecks experienced by the employees retrieved via interviews. Cause and effect of these bottlenecks are weighed to each other. Mostly they are quantified in hours or money.

A brown paper session describes the process, what, whom, where. The first activity in a brown paper session is defining the different steps within the chosen process for analysis. Next is the question “what is needed”. E.g. when recording medical records, the medical file of the patient is needed to update it with medical information. The following question of the brown paper session is “who” is responsible, or the subject who acts in the specific process step. In the example of updating the medical record, the physician is responsible. The last question is “where” the process step takes place. When looking at the example, the activity takes place at the nursery unit by the bed of the patient where the medical record is updated.

The advantage of doing a brown paper session is that the whole process can be analyzed in stead of one object. The disadvantage is that chances are that less operations and bottlenecks of a single process step are exposed.

Indicators for process analysis are setup in advance. Key players within the process are involved to work out the process. The most relevant parts, mostly the parts with bottlenecks, will be scrutinized and questioned more extensive during later feed appointments.

The third phase determines the improvement potential of the cluster. During this phase the level of ambition is set, the goals and results are quantified. When necessary, the process can be redesigned so the core measures are appointed. When (re)designing processes, steps that don't add value should not be put in, and should be removed. A reduction of preparation time, final processing time, control time, waiting time, transfers is wanted.

There is a great amount of consistency in the TBO and the process analysis. In theory the outcomes should complete each other. After the preliminary process analysis the TBO was altered to aim the focus more on the bottlenecks that came up during the process analysis. The measures will bring more relevant data for decision making about efficiency. The feedback of

³ During this research a couple of saw tooth researches took place. The main goal was to get a good insight of how a unit works and get familiar with the content of their work activities. In other words getting insight in existing processes and their bottlenecks. This insight was obtained by interaction with the subject(s) and the possibility of asking questions. Some elements of the saw tooth research were input for the process analysis.

The saw tooth method, on itself, is very labour-intensive. In the saw tooth method an object is followed through the process. That object can e.g. be a patient or a patient record. The object runs through the different activities or stages within the process. These activities and their location are carefully written down. The goal of the saw tooth method is gaining insight in the process (what, whom, where), in transfer moments, in double work, in the walkthrough time, in bottlenecks and differences in processes between the locations and patient flows. When using such a method, delay's can easily be spotted. It gives a good insight in the daily work that is done. Efficiency problems like double work, e.g. double patient registration, can be detected fairly easily using this method. A disadvantage is that flaws do not come forward in every process of a single object. Therefore it is not a very valid method, but it gives clear indications on efficiency of the current situation.

TBO-data, is suppose to bring more light on the bottleneck of the processes. The TBO results are used as a foundation to pinpoint the bottlenecks that exist.

As stated before, data of the other researches are also used as feedback for the process analysis. Their outcome is the input or validation of the process analysis. When e.g. more patients state that the attention an information they get before surgery is too little to their perception, it's a point of discussion during the process analysis. A cause could show up in the results of the TBO. That way the complaints patients are confirmed in hard numbers.

3.2.2 The Case Study

During the RvN project, multiple process analyses were done. The process analysis of the unit Obstetrics are discussed here. Because of limits in time, not every process can be scrutinized for the RvN project. To reduce the occurrence of redundancy during the process analysis preparatory research takes place. An inventory of the cluster was done. The supporting and primary processes were explored. The result was a global view on most of the processes that exist within the cluster. The main goal for doing a process analysis was pinpointing bottlenecks. The other general goals and reasons of doing a process analysis are summed up in section 3.2.1 and will not be repeated here.

When beginning with the preparations for a process analysis, available documents on the Obstetrics unit were scrutinized. From that scrutiny it became apparent that little documentation about processes exists. Within the unit, written arrangements about the process weren't recorded. They were only arranged on oral agreements. The analysis of the process therefore had to begin with a blank piece of paper. To get some information about the units, a couple of actors were consulted during the preparations. By interviewing them, certain points of attention in the process already came up. These points were used as the input for the process analysis.

The method used for doing the process analysis was the brown paper session, mentioned in the previous paragraph. During a brown paper session experiences, needs and ideas from different points of view were brought together. Especially in a multi actor environment these different viewpoints are important. Every actor has its own role that must be documented during the brown paper session.

Within cluster 12, the biggest units are the policlinic and the Obstetric clinic. There is one group of patients which visit both units for the same health related topic, namely pregnancy. Pregnant patients begin their process with their visit to the gynaecologist in the policlinic. The gynaecologist runs a couple of test, e.g. examination of blood, and makes further appointments when possible. Eventually the patients enter the Obstetrics clinic. They mostly enter after 38-42 weeks of pregnancy. But earlier entries are possible when e.g. problems occur. The problems encountered cover a great range. Patients with problems can be forwarded by the General Practitioner, another gynaecologist from another hospital, an ambulance etc.

The selection of choosing a process to analyse was discussed in section 3.2.1. Reasons for doing a process analysis for Obstetrics were:

- A walk through of approximately 2000 patients a year
- The patient process attends two different units within cluster 12
- A long walk trough time of nine months on average
- Present signals about communication difficulties between the two units (complaints about communication between the clinic and the policlinic)

- The multi disciplinarily character (gynaecologists and nurses have to work side by side. Pediatricists also work on the Obstetric unit, but they are from another Cluster. Therefore they are not involved within the research.)

Three important groups within the unit Obstetrics can be identified. These groups are the nurses, the administrative staff and the gynaecologists. The criterion for this classification is that each function must be involved directly with the patient care within the process. The group has to have a direct interaction with the patient. E.g. the administrative worker behind the counter that has to fill in the required information that is needed for the different kinds of patient administration, or making new appointments. The involvement with the patient by the nurses and physicians speak for themselves.

Delegates of the groups were questioned separately. The nurses were the first group to do the brown paper session. This choice was made because within the process of a pregnant patient the nurses are involved in most of the process steps from beginning till end. They are also well aware on what tasks the administrative staff and the physicians have. With their knowledge a nearly complete process analysis was written down. After the session with the nurses two more sessions took place. The next session was with de delegates of the administrative staff. The last session was with the physician delegates. These two groups had the opportunity to complete the process analysis with their process roles and knowledge. Because of the process been written down already, the other groups had an incentive to see if it was right. It seemed that the groups were very motivated to make sure their roles were written down correctly. This brown paper session finally resulted in the process analysis shown in appendix 4.

3.2.3 Results Process Analysis

Doing the process analysis, a lot of information about how the workflow at the obstetric unit was organized came up. A piece of the process analysis is stated in figure 8, the process flow. Three bottlenecks retrieved via the process analysis are discussed next. They were randomly chosen to give better insight on what information was retrieved with the process analysis. The numbers written down in the process analysis correspond with assigned bottlenecks.

The first bottleneck, assigned as number one in figure 8, is about the laboratory activities. The blood group of many in labour going women is unknown. When the patients go to labour an improper emergency stipulation of the blood is needed. This can be very stressful because time is scarce when a patient gives birth. Normally the blood tests take place when the patient first visits the policlinic at the beginning of the pregnancy. The blood test is not always done there. When the patient gets an admission when going into labour, another obligatory blood test is done. In terms of safety two blood tests are necessary for fault reduction according to the protocol. Sometimes patients enter via other peripheral hospitals or are brought in by ambulance when pregnancy problems occur. In this situation it is quite logical that there isn't any information about a blood test in the Erasmus MC. The bottleneck is that blood tests aren't always done at the policlinic. Due to unclear communication, the blood test is sometimes forgotten. This causes more workload at a different place in the process and hospital in a much more stressful situation.

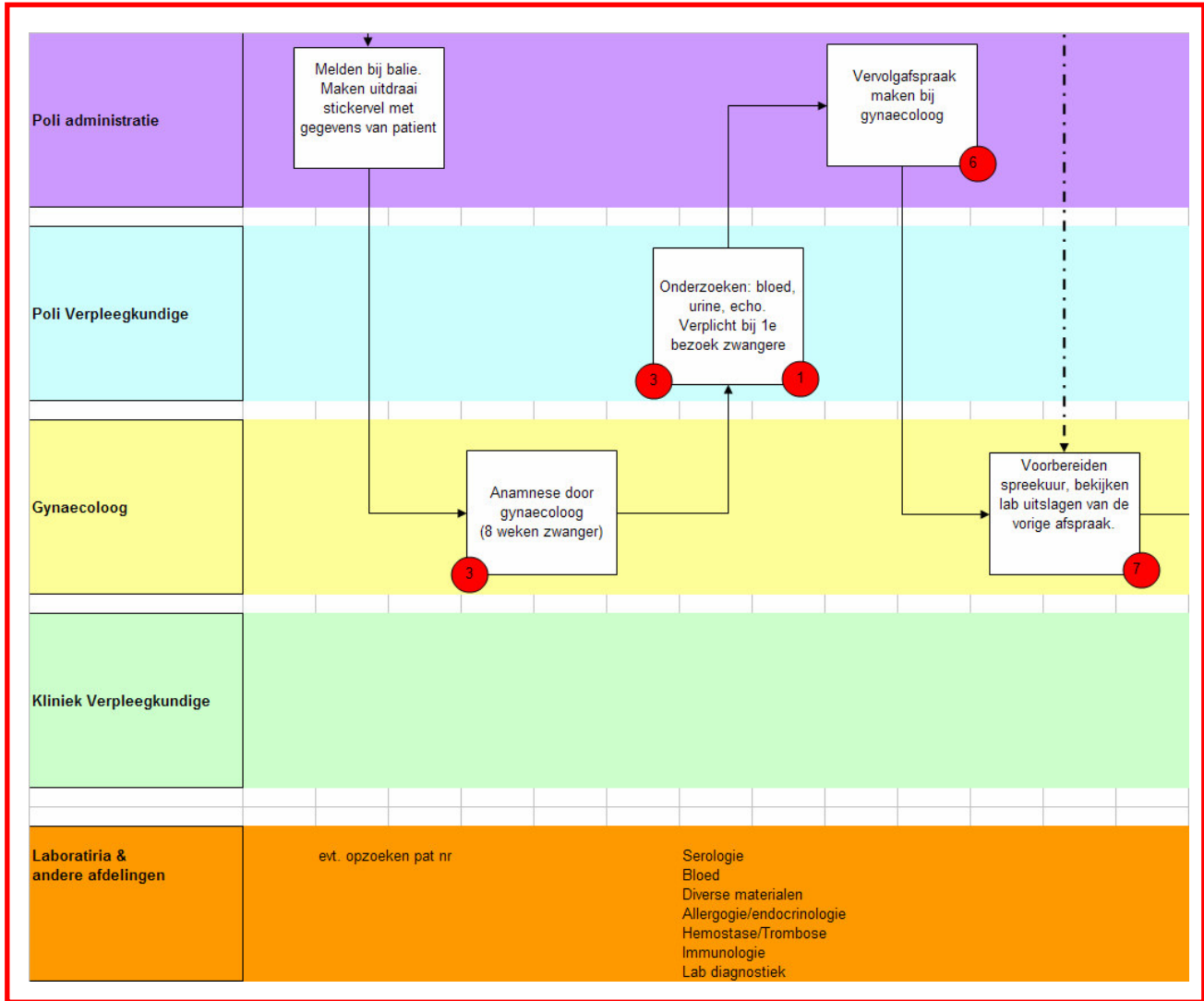

Figure 8: Process Analysis, a piece of the process flow

The figure shows the different actors on the left side, each with their own colour line. Each square represents a care activity. The orange flow represents activities done by other units. The red numbered circles are experienced bottlenecks at that location in the process.

Gebuurkte systemen	ZIS									
Papieren status	X									
EVS aanmaken	X							X		
DBC	X									
Astraia	X							X		
Overdracht										
Overdracht Powerpoint										
Elpado										
Partusbrief										
Medicator	X							X		

Figure 9: Process Analysis, the Information flow

The information flow shows the systems that are used at a certain care activity. Figure can be placed directly under figure 8. The coupling gives a clear image of the information and process flow. The first activity requires the usage of 5 systems, marked with an X.

Another experienced bottleneck in the process analysis is the lack of a specific nurse consulting hour for admittance pregnant patients, number 5 in figure 8. Gynaecologists perform tasks that really aren't part of their job. They also work from within a whole different viewpoint in comparison with the nurses. Details in care are forgotten or aren't labelled as important. Delivering care at the wishes of the patients is therefore harder to realize for the different target groups on the obstetric unit. One of those aspects is psychosocial care after e.g. a drastic birth. After such an event the patient should get more attention and receive more care. Tasks should be redefined and divided in such a way that the expertise of both parties is optimally used for giving the proper care to the patient.

The third bottleneck, number 7, is about answering questions of patients via telephone instead of in person. At this point there is no telephonic consulting hour for the patient to discuss her questions with an expert on the topic. When a patient phones, promises about calling back are often made. What happens is that the patient isn't phoned back by the right expert. The effect is that the expert has to make ad hoc decisions during his/her normal work, when a patient phones up with a question. Making ad hoc decisions consumes more time from the expert and the delivered service isn't experienced customer friendly by the patient. An example of realizing efficiency can be gained at several levels. First of all efficiency can be gained in the treatment towards the patients. Second, taking away the inefficient ad hoc character of answering questions of the patient.

3.2.4 Administration bottlenecks

One of the more general outcomes of the process analysis was the amount of administrative data that has to be registered within the pathway of a pregnant patient. It appeared that a great amount of systems is used to do administration in the Obstetrics process. The registration of the usage of different systems is displayed in figure 9, the information flow. The used systems at a certain care activity are marked with an X, see appendix 4. Signals from the different delegates involved with the process analysis, were about the experienced double input. E.g. when a patient gives birth, the name, birth weight and date of birth have to be input in three different systems. These forms of double input cost a lot of extra time and loss of capacity. Other signals about double data input also came up during the analysis. Therefore further scrutiny about administration bottlenecks was needed, because it is an important source to gain more efficiency on the Obstetrics unit.

Using the process analysis of Obstetrics as a guiding principle, a survey for administration bottlenecks input was done. The same group of delegates were questioned about which input is needed at what step of the process. The survey consists of two steps. The first step is to find out which systems are used to administrate certain information elements. Each information element that is inputted is coupled to the system(s) in which it is recorded. The inputted information can be stored digitally, on paper or other means of data storage. E.g. the birth data of a newborn child is recorded in several systems. The second element of the survey is the actual amount of double time spent on registering the information element in the specified systems. Appendix 5 and 6 show the actual time each element takes to fill in at the specified system. For the research a couple of nurses and gynaecologists contributed. They had to fill in the time spent on registering each information element in the specified systems separately from each other. Data from the nurses and the gynaecologists are separated. This because they both have to fill in patient

information in different systems. Nevertheless a clear image about the average time spent on one patient is observed.

Another aspect that can be seen is that certain information elements are inputted more than once. The element that is inputted the most is the birth data. It also takes a fair amount of time because it cannot be transferred easily between systems. This information element is inputted in 8 systems. Almost the same can be said for the gynaecologist. Information elements on birth, on birth data (child) and on take in and firing patients.

In the described process of Obstetrics, a gynaecologist spends 171 minutes on average on one patient during the described process. They have to document their data in 12 different systems⁴. On a daily basis they spent 11% of their work time on administration on an average day. A nurse spends approximately 55 minutes on average per patient on administration. Nurses use 11 different systems⁵ (digital and paper) to input their data on the patient. The nurses have to fill in thirteen forms or computer screens. On an average day, 10.3% of their available working time is spent on doing administrative activities. In comparison with other units, the amount of time spent on administration is average.

With this data, calculations of the amount of double time spent on a yearly basis can be made. Calculations are made on basis of the net FTE's (Full Time Equivalents). This means that a correction of vacation hours, sickness, holidays are taken into calculation. In this calculation the viewpoint is taken that a nurse has a standard working week that consists of 36 hours. For the gynaecologists this is 40 hours. From the tables in appendixes 5 and 6 double time is calculated as follows. The system that takes the least time for an information element to input is used as standard. All the other time spent on input in other systems is aggregated. This is done for each information element. This aggregated time is the double time. To calculate the double time in FTEs, an average of 2000 births a year is used as given.

After calculation the double administration that is done is approximately 0.70 FTE for the nurses and 2.58 FTE for the gynaecologists. This is a pure loss of time. This scrutiny gives a good indication of the inefficiency of the administration. But for a validated outcome this scrutiny has to be expanded more.

The consistency of data can probably be a bottleneck when using more systems. The question is where the professionals look when they need patient information? Or in how many systems do they have to look to get the patient information they need? The gynaecologists have a whiteboard in the physician room. In this whiteboard all the (directly) important information about the patient which lies on the unit is written down. Information such as the history of the patient, e.g. how many miscarriages the patient had, and information about the medication and treatment are also on the whiteboard. They said that the whiteboard was the place where all the most up to date information about the patient is written. When they need information about the patient, when doing the patient visits, they look on the whiteboard and not in the computer systems. One other reason they gave was the well organized interface that the whiteboard has above all the different systems. Much of the information from the whiteboard is later administered in the different systems.

⁴ The 12 different systems used by the gynaecologists are: the paper status, EVS, DBC, Astraia, transfer in Powerpoint, partus letter, OK-report, partus book, PA-form and the whiteboard.

⁵ The 11 systems used by nurses are: ZIS, EVS, Partogram, Mosos, Obstetrics Form, Nursing status, birth cards, baby list, intake book 1 and intake book 2.

All the above only states the time spent when administrating data into the systems. Looking up data is not included here. The looking up of patient data involves additional systems. After questioning the nurses and gynaecologists, they said that looking up patient information also more than one system is used. The patient information needed is scattered over different systems. This makes it harder to find and retrieve the correct and most up to date information is.

Changes are necessary if this problem should be solved. Thinking about the figure from chapter 2.1, there are three important factors that each plays its own role. These factors are Processes, People and ICT. All these three factors have to be changed, to get to a solution. When altering ICT, or implementing new systems, Processes and People have to be changed first. When the process is not in order or the people don't want to participate, the implementation of the new system has a little chance of succeeding.

3.2.5 Coupling the Results

This chapter contains a lot of bottlenecks. These bottlenecks were retrieved via different means. Some were retrieved from the process analysis, others from questioning or observations. It's interesting to look whether coupling some DMO researches validate bottlenecks.

Previously in this chapter, the fact that processes aren't written down was briefly discussed. Agreements on the process are made orally. Otherwise existing protocols are followed. This occasionally results in ambiguity about the activities that must be done. The ambiguity also comes forth from the MTO (the employee satisfaction research). The nurses as well as the physician assistants have a role conflict. A role conflict implies that contradictory assignments are given. It also results in a lot of irritation because of ambiguity. During feedback the clarity of this problem was acknowledged. It was stated that the gynaecologists and other physicians, such as a paediatrician, often give contradictory assignments. Sometimes these assignments are withdrawn. Other reasons for the ambiguity is that not everybody is familiar with the contents of the protocol.

The very busy mornings for nurses at the obstetric unit is discussed in paragraph 3.1.2. In the morning the nurses have a lot of activities. Some of these activities are about giving physical care, making up the beds, distributing food and fluids, washing patients. Also stated in paragraph 3.2 is that these results coincide with the results of the TBO (the time measuring research). In the results of the TBO a high peak is seen in the direct and indirect patient time, the activities just summed up. But the MTO also states this bottleneck. In the MTO the question about commitment with the workplace scores much higher than average. This means that the employees experience that their work does not easily allow them to get a cup of coffee or walk away to another unit. In the feedback discussion, the employees recognize this result. They say that they don't allow themselves to go on a break or something, before the work is done. This has a clear result in the registered peak during the morning activities in the TBO research. This bottleneck also illustrates the intertwined character of the different DMO researches.

The accessibility of health care professionals via telephone is also a problem within Cluster 12. As stated in chapter 3.2.3, this has to do with the lack of a telephonic consulting hour. The needed healthcare professional also isn't always available. On the other hand there are also problems with the telephone exchange. The call of the patient hardly comes through to the

healthcare professional. Results from the PTO and CTO (respectively the patient and client satisfaction research) clearly emphasize the poor accessibility of telephonic services and the opportunity to ask questions to the healthcare professional.

3.3 Conclusions

In this chapter many bottlenecks were discussed. The next chapter is about working towards a solution for the existing problems or bottlenecks that exist. The bottlenecks that are stated in this chapter can't all be solved in this thesis. The focus will be on the main problems, concluded from this chapter. The three intertwined factors, people, processes and ICT are present in these problems. The following problems are concluded from the analysis of the Obstetric unit.

1. *Lack of alignment between existing processes and ICT*

Many ICT implementations aren't based on the workflow of the unit where the implementation takes place. As a result systems are not 100% compatible with the processes. Other than that, implemented systems can often do a lot more than what they are used for. Without a good alignment with processes, ICT implementations are not optimal effective and efficient as they could be. A better alignment can result in better patient quality and a reduction in costs.

2. *Involvement of relevant actors at decision moments*

At this moment the medical staff makes decisions about which systems to use and their specifications. They cooperate with the ICT department and have information meetings. During these meetings different systems, options and specifications are discussed. Input from other actors, such as physician assistants and nurses, are not taken into consideration. These other actors will eventually be the end users of the system. The lack of their input is a loss for the workability of the system. The medical staff argues from within their own perspective. This results in systems that could work more efficiently, because the medical staff is less involved in the primary process than a physician assistant. Because of their incomplete knowledge on the level of operational management, their decisions have a risk of resulting in an incomplete fit with the unit. This could have a negative influence on the satisfaction of the actors that have to work with the system.

To recapitulate, the people who have to work with the system are very important. They are responsible for the good functioning of the unit. Involvement of more actors is to make sure ICT implementations have a good fit within the unit.

3. *Existence of inefficient administration*

People and ICT aspects are clearly intertwined at this point. The high number of used systems is perceived as normal by the people who work at the Obstetric unit. Due the vastness of systems, a lack of communication between them exists. As a result a lot of patient information has to be inputted more than once, the so called redundancy. Another danger of redundancy is that it is unclear where the most recent patient information can be retrieved. This could have a negative effect on the quality of patient care. The input that needs to be done in different systems desires that the health care professionals have knowledge and skills to operate all the different systems.

4. The lack of Management Information use

The quantity of administration done is therefore very high and a lot of patient information is inputted more than once. From all that input useful Management Information (MI) could be accumulated. But actually there is little or no use of MI in the obstetric unit. When the gynaecologists need MI they contact the ICT department who distillates the requested MI. MI can make trends visible which on their turn can be the basis for the planning of capacity. MI can also be used for future medical research. The usage and arrangements of MI must be specified up front. This can be quite difficult. Using MI for research is even more difficult because these data will only be needed over 10 years. To be short, this subject could gain efficiency but it requires proper specifications.

In the conclusions people, processes and ICT are clearly represented in the main bottlenecks. In picture 10 the bottlenecks are placed within the conceptualization model. It can be clearly seen that most of the bottlenecks are placed in the overlapping areas of the three factors. In the next chapter, these conclusions are the basis for working towards a solution.

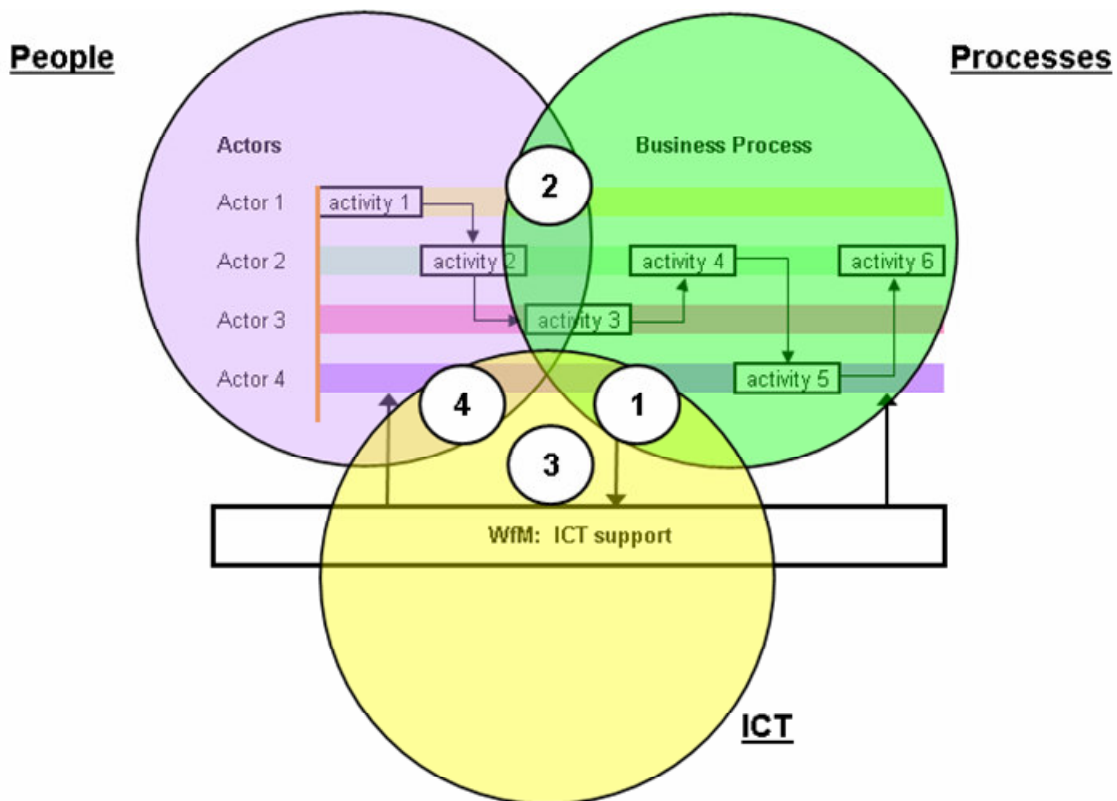

Figure 10: Bottlenecks Integrated in the Conceptualization model

Chapter 4: Towards Solutions

As can be seen from the results from the analysis stated in the previous chapter, a lot of bottlenecks exist in the Erasmus MC and at the Obstetrics unit in Cluster 12. The aim of this chapter is to work towards a solution that can solve the four main bottlenecks stated in the last paragraph of the previous chapter. In this solution the emphasis of the use of ICT is done after discussing the influence of and on people and processes.

4.1 Integral look of the main bottlenecks

If we look back at section 3.3, we see the most important bottlenecks described. This paragraph takes a look at these points and gives possible solutions. The focus of 4.1 will lie on the process and people aspects.

4.1.1 Lack of alignment

At the beginning of this section we will take a look at how the process of an ICT implementation takes place in the Erasmus MC. Requirements from different Clusters, units or from a central level (the customer) are received at the ICT department. These requirements are then worked out very carefully. This happens often in consultation with future end users such as physicians for example. These consultations or information meetings, give a better reflection on how the specific organizational unit works. The perspective offered using this method is not as extensive and complete as might be necessary for creating and implementing ICT. The general patient process or care pathway is often a neglected topic. Within an ICT implementation project and in the information meetings, processes aren't really scrutinized or discussed. The reason why processes are mostly neglected is that agreements about processes aren't really made in general. On the Obstetric unit processes aren't documented. Therefore the conclusion can be drawn that the unit isn't process oriented at all. At the unit, scrutiny of the existing processes does not take place.

The ICT department is not specialized to do such scrutiny. This is the reason the ICT department doesn't do process analysis. Remarkable is it that the customer thinks that the ICT department should do those scrutinies. The ICT department on the other hand thinks that process analysis is a job for the customer or the management of the unit. Besides doing an analysis of the processes, comparisons with other systems aren't always done. This is also not a subject on the agenda of an information meeting. A lot of systems operate as standalone systems. Little integration with other systems exists. As a result redundancy factors are mostly neglected. The standalone systems also lack underlying communication. All this could lead to problems. A couple of these problems, seen by physicians, are discussed in paragraph 4.1.3.

The main bottleneck of the Obstetric unit is the lack of alignment between people, processes and the implementation of ICT. The cause of this lack is ambiguity about who is responsible for looking at the processes. The unit thinks that the responsibility to scrutinizing processes lies with the ICT department. The ICT department on the other hand says this is the responsibility of the unit itself, because knowledge about processes is not present on the ICT department. It's important to give responsibility for the process analysis a place to get a good alignment with ICT.

This bottleneck is also proclaimed by Klischewski & Wetzel (2001), stated in section 2.3. They wrote about the problems that exist in health care concerning the processes. What they saw was a lack of overall responsibility for the process or the planning of the process. This is also the case for the Obstetric unit. Responsibilities for and in the processes must be defined. Most logic, the responsibility for the involvement of processes in ICT projects must be at the unit itself. The unit has all the knowledge of the activities and information flows that take place. When units are responsible for the processes, the people must also be involved in the analysis and the project itself. All involved actors must be able to deliver their input in the project. The role of the ICT department should therefore be more coordinating. They have to coordinate the alignment of the process with ICT. This could mean that the ICT department is a mediator during consultation. The advantage of being a mediator is that the ICT can be guaranteed and that there should be no surprises further in the project.

But other than the alignment on unit level, alignment with other units within the Erasmus MC must be realized. Especially when talking about ICT implementations that are to be implemented in the whole hospital. Units must than look over the boundaries of their own unit. The culture in the Erasmus MC is focussed to only look at their own unit. This could have negative consequences when talking about ICT projects on a macro level. This cultural aspect must be broken. A scope must be predefined to prevent only looking at the micro level of the unit. This scope must also be guaranteed. This must be organized from the central management level of the hospital. They must create more awareness and emphasise the importance of looking at other units. Representative of the units must have regular consultation with the central management and other representatives. This must result in a better design for hospital wide ICT solutions with the right specifications.

4.1.2 Involvement of relevant actors

Before implementing or beginning with an ICT oriented solution, processes and people have to be adjusted first. Scrutinizing the processes is the first step to be taken. Together with the involved people, the process can be adjusted if needed. After adjusting the process the people have to be made ready to work in the new situation. That means new ways of thinking and working need to be learnt. This goes together with learning how to work with the new ICT that is going to be implemented. This way the adjustments made in the process can easily be taken over by the employees. Most important is it to describe the process and the information flow and to document it well. Future alterations in the process or information flow can be done more easily that way.

When analysing the process, all the different actors within the process should be involved in the analysis. Their opinion and vision can have a great contribution on the development of a system. The medical staff, the customer, must be responsible for involving all the necessary actors. The ICT department must see that this actually happens and must steer this process when necessary. It is also necessary to involve the actors in the decision about the ICT system and the arrangement of it. When their input is neglected, the ICT system will end up as user unfriendly. When a system isn't user friendly it enhances the chance of making more mistakes. People will work around “barricades” instead of following the protocol.

Another point of attention is the differentiation of tasks within the information process. If differentiation of tasks is needed, the time to make adjustments is before discussing ICT solutions. All actors have to learn to think differently. Other than that they have to act differently. New ways of doing your work have to be taught and trained. This learning and trainings process

costs a lot scarce time form the health care professional. A disadvantage is that the budget reserved for training, when a new system is implemented, is mostly for one year. After that year the knowledge of the system evaporates. This is caused by the migration of people from the unit. Important is that the vitality to change on the unit must be large. When that is the case, people are more open to changes. In the case of the Obstetric unit, the vitality to change is large, which is a good thing if changes are to be made and the people have to learn new way's of working and thinking.

At this moment decisions about ICT are made by the higher medical staff. The involvement of other actors, such as nurses and physician assistants is limited. A disadvantage is that the tasks done by the higher medical staff differ from the other actors. The higher medical staff doesn't have complete knowledge of the operational level. The decisions they make, therefore do not fit the tasks of the other actors fully. As a result of that, a system can get implemented which isn't as efficient or user friendly as it could be. Another negative effect is that some actors feel that they are passed by. All of this can have a negative impact on the work environment.

Representatives from different function groups should be part of the decision. Operational, tactical and strategic knowledge must be present when a decision is made. The function group which has the best knowledge of a subject must have the lead in making the decision. This group of representatives should also be involved by the alignment of the processes with ICT. Their opinions can have a great contribution to the project and it also should make broad basis for the project.

4.1.3 Administrative bottlenecks

In section 3.2.4, the bottlenecks about the administration were introduced. In this paragraph the bottlenecks are set out to take a closer look.

The following bottlenecks occur. First of all a lot of systems are in use within the obstetric unit. Secondly, because of the large amount of systems that are in use, a lack of communication between the different systems exists. As third, redundancy due to the amount of systems occurs. This results in the next bottleneck about where the health care professionals get the most up to date information from. The final bottleneck is a logistic one. It's about which system to consult to get the information you need. These are the bottlenecks that cause inefficiency on the Obstetric unit.

When doing further research, nurses and gynaecologists appeared to use 33 different systems to administrate patient information. The nurses have eleven systems and the gynaecologists use twelve other systems for the administration of patient data. A system can be digital, being software, as well as it could be a sheet of paper that is collected in a paper patient file. These systems are mostly used for electronic storage of patient information. The majority of systems function as standalone applications.

These standalone characteristics are common for the systems used in the Erasmus MC. Integration of systems is very limited. When used, most systems require their own registration and authentication. A great disadvantage for the users is that the interfaces and usages of these systems differ a lot from each other. The different systems also require specific skills and knowledge to operate them in a sufficient and accurate manner.

Because actors, such as gynaecologists, nurses and administrative staff, have different interests the organization of the administrative process is not optimal. The dividing of tasks to the

functions is a cause of that. Nowadays there is a transition of workload. For example the administrative staff does tasks formerly done by the gynaecologists. This means that other systems have to be used, or other information has to be inputted in the current used systems. As a result administrative bottlenecks occur.

Communication between programs is another bottleneck. At this moment little communication between different programs is possible. The fact that there are quite a number of internal and external suppliers of these programs is not improving the internal communication between these programs.

Several physicians think that a situation as described above can have negative influences on the care offered to the patient. These influences are:

- A reduction of working with electronic systems when the aim of the Erasmus MC is to abolish the paper status of the patient;
- Redundancy. Because of the lack of integration and communication, patient data has to be inputted in different systems;
- The occurrence of medical errors. Looking for extra data in the variety of systems is very difficult. As a result patient data can easily be overseen. Redundancy on the other hand can be responsible for ambiguity about the most recent and correct available patient information.

When using both digital as paper systems, the danger of redundancy gets bigger. E.g. birth data of the newborn child has to be inputted in several systems by the gynaecologist. The danger of redundancy is recognized by the physicians. It appeared that 135 minutes spent on doing all administration for one patient is double time. This time spent on doing double administration is a significant percentage of the available capacity.

Another important question about the double administration arises. This question is about where a nurse or a gynaecologist can find the most reliable and most up to date patient information. Because of occurring redundancy, information is administered more than once in different systems, mistakes such as typing errors or the lack of administering data can be made quite easily. Physicians already made their complaints about increasing chances of medical errors. For the gynaecologists working on the polyclinic, the most up to date and reliable data of patients currently occupying the unit is easy to find. In the physician room a big whiteboard hangs on the wall. On this whiteboard a selection of patient information, from the patients who are occupying the unit is written down. The information on the whiteboard was about a brief history of the patient on the area of obstetrics, current information such as lab results or a treatment plan. Every gynaecologist takes a look at the whiteboard when they are about to see a patient or at the beginning of their round. New information is firstly put on the whiteboard. At the end of the day, or when there is time, the physician-assistant puts the patient information in the desired systems. This encourages redundancy and can enlarge the faulty inputted data.

Another disadvantage is that knowledge and skills that are needed to work properly with these systems. This sometimes causes irritation by the user. Other than that, a fair amount of time needs to be invested to learn people working with these systems. Of course this is a very important and necessary point, but when several systems need to be mastered time investment is very high.

Another bottleneck discussed by Klischewski & Wetzel, stated in section 2.3, is the exchange of documents, which is partly the case in the Erasmus MC. The problem that occurs is that the exchange information, in the form of documents, from different applications can't always be done. This encourages redundancy and makes it harder to retrieve the most up to date

information. Klischewski & Wetzel states that clear rules about documentation and document exchange must be made up front.

A solution to prevent redundancy and were to find the most reliable and most up to date patient information is to make clear agreements. Agreements about inputting data and the use of e.g. the whiteboard need to be made. The result must be that reliability of information increases. Points where redundancy occurs must be handled with more attention so that faults are made less. The specifications for preventing redundancy must be discussed when processes and alignment with ICT are discussed within the project. When discussed too late, the effort of preventing redundancy will be more. The most important goal of the agreements of working with the systems is that errors are prevented. This way the chance on medical errors is reduced as much as possible.

4.1.4 Management Information

When administrating a large amount of patient information, theoretically Management Information (MI) should also be large. But most of the administered patient information on the Obstetric unit isn't used. The patient information isn't used as Management Information, not by the gynaecologists as well as the management. One of the reasons for that is that MI isn't easy to analyse, at least not in the current situation. In most systems of the Obstetric unit MI must be calculated by “hand”. This consumes a lot of time. The most remarkable is actually that much administration is done because it has to be done. Information written on the whiteboard is copied in the computer applications. Once it has been inputted, it will never be used again. Inefficiency occurs because the patient information isn't used after administration. Patient information can be used on three different levels. It can be used for MI, for (medical) research data and for Business Intelligence.

Patient information is stored on two different levels. It is stored on a decentralised level such as a unit or Cluster and on a central level within the Erasmus MC. Information retrieved from these different storage places, differs a lot from each other while they should be the same. Looking at this fact, problems on financial area's can be a serious problem. There isn't any kind of intention or any kind of good working infrastructure. This can lead to great financial problems.

What needs to be done is to create awareness about the import and requirements of MI on the unit. The 11% of time spent on doing administration can be used more effective. Choices about how to make a better use of the administered patient information has to be made. This has to be done on the three different levels, because they have other requirements towards the data. The best point to discuss this is also when discussing the process. Mechanisms can be constructed and implemented in a way that they fit best and can be altered in the future when necessary. When having MI, and using it on the patient workflow, control of the workflow and use of capacity can be more efficient.

4.2 ICT as supportive solution

Working towards a solution, alignment of the workflow (process) and ICT play an extraordinary role. The workflow is the backbone of the path that patients follow during their stay in the hospital. Using workflow as the centre of delivering care, the patient is put on a central pedestal.

After the analyses in chapter 3, bottlenecks were set out. Only the concluded bottlenecks from section 3.3 play a role in this chapter. The focus of this paragraph lies on the information flow of the process and ICT related solutions.

4.2.1 Information Architecture

The main conclusion of paragraph 4.1 was the lack of alignment of the existing processes in the healthcare with the implementation of ICT systems. In paragraph 4.1 the emphasis was laid on an organizational solution, from the perspective of people and processes, to solve this bottleneck. In this paragraph the emphasis lies on ICT as a supporting solution for this, and the other named, bottlenecks.

In section 3.2.3 a figure of the process analysis is placed. What can be seen is that the workflow and the information flow are separated from each other. These flows also function separated. This is a loss of efficiency which has its effect on the different administration aspects. To give a solution for the bottlenecks of the alignment of the processes and ICT and for the administrative bottlenecks, integration of both the workflow and the information flow seems necessary. This integration can only be done if the workflow and information flow are scrutinized. As a result of scrutiny both flows have to be adjusted in a way that they are more optimized by integrating them. Sometimes organizational factors and people have to be adjusted as well. These process and people related factors are treated in the paragraph 4.1. Till this far ICT does not play an important role. But when using it as support to realize alignment as a solution, ICT is indispensable. Lets look take a look at the solution from an ICT perspective.

Before the information flow and the workflow can be joined the process (workflow) and information flow must be clear. Scrutiny of the process and information flow has to be done before you can discuss an ICT oriented solution. This means that a set of rules, routes and roles in the processes need to be declared and agreed upon. The different actors who are involved must be known for instance. Also the pathway of the patient must be declared at forehand. The patient has a central place in the process. The process and workflow are formed around the clinical pathway of the patient. Rules are used to create a clarity for who does what at a certain point in time. Figure 11 represents a model for joining the information flow to the workflow, or the clinical pathway a patient follows. The “block” above represents the new and adjusted workflow. The block below represents the information flow. When having a clear and more efficient workflow the next step can be taken. The next step is to organize the information flow. This can be done by using a Workflow Management System (WfMS). Both flows are joined to one and another via the WfMS.

What a WfMS does is taking care of the information logistics of the process. In other words; a WfMS takes care of delivering the right information at the right time for the right person within the right application. The WfMS can be seen as middleware of the business process. It is a “middleware” platform that integrates diverse applications such as the HAD systems. (Cardoso et. al. 2004) To do all of this, a WfMS must be able to access and work with all other existing systems, databases, legacy systems and can interact with the users. The arrows represent the information flow between the process and the WfMS. The downward going arrows are the patient information that is inputted and then stored in the right application via the WfMS. The up going

arrows are the patient information that is retrieved. This information could e.g. be historic known data of the patient or lab results from a previous taken blood test.

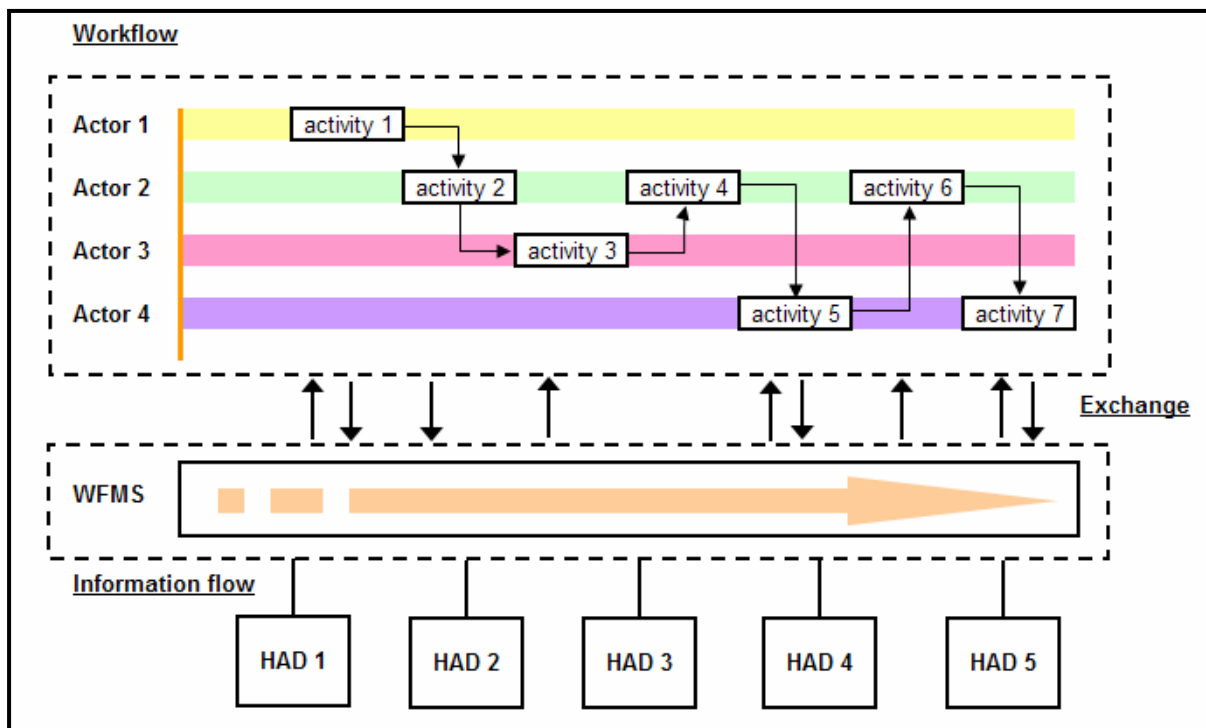

Figure 11: Model of a Workflow Management System

The HADs are coupled to the WfMS and together they represent the information flow. The top of the figure represents the process flow with different care activities. The involved actors in the process are stated on the left hand side. The exchange of information is stated by the arrows which couple the process flow with the information flow.

The advantage of WfM is that it is component oriented. Support is given to interoperability among loosely couple components. These components correspond to the so called HAD (Heterogeneous, Autonomous and Distributed) systems. These systems can be new systems, current systems or legacy systems. The advantage of a WfMS is thus that the existing software packages still can be used in the new situation. The HAD-systems are coupled to the WfMS. The user has access to the WfMS. The WfMS makes contact with the specified HAD-system and information can be exchanged. A HAD system could e.g. be the lab system where test result information is inputted. The coupling of HAD systems to the WfMS is seen in figure 11.

The primary task of the WfMS is thus getting the right information at the right time in the process in the right application and make sure that the right person gets the information. When having a blueprint of the workflow and the information flow, such combinations can be made. Such a step can easily be taken to the next level. This can be done by implementing push and pull mechanisms in the workflow. Push and pull mechanisms can in fact be used as an extra control mechanism for the healthcare professional. The pull mechanism makes sure that the specified healthcare professional sees the information he is supposed to see when the patient arrives at the next care activity. Lab results are a good example to use as a push function. When new results are available the physician immediately sees that these results are available. Using this push

mechanism as a fail safe, the changes that a healthcare professional misses an important piece of information get smaller.

The pull element works just the other way around. The pull can be used for important data input that must not be forgotten by the healthcare professional. This could be requests for further research such as an additional blood test or an ultra-sound scan, or a checkbox for no further researches so a healthcare professional is aware that no points are forgotten. But to fill in push and pull mechanisms, the process (workflow) and information flow must be known and scrutinized at forehand. Otherwise, just like arranging the WfMS, it has no use and will create more inefficiency in stead of efficiency.

4.2.2 Solution for the Obstetric unit

The keyword for a solution for the double administration at obstetrics is *integration*. Not only the integration for the information and workflow, but also for the number of systems used at the obstetric unit. The number of systems, where double administration takes place, must be reduced. The solution that is needed is one integrated system where all patient information can be administered or looked up. All the used functionalities of the obstetric unit should still be available in the new situation.

An alternative is to implement a whole new system which has all the necessary functionalities. From a realistic point of view this alternative is much too expensive. If such a system even exists, it would also need a lot of work to make adjustments for a good fit with the unit. People who have to work with the new system also have to learn a whole new way of working and must be ready for the new technology. Therefore implementing a whole new system is not realistic.

Another alternative is integration of systems done by using the information workflow as a guide line. In section 4.2 the conceptual model of the WfMS is explained. This model is applicable on the obstetric unit. The advantage is that the currently used systems can still be used in this architecture. There is no necessity to implement new systems. This saves time, costs and effort. The current applications can still run independently from the underlying WfMS. The only aspect which is necessary is that the information flow and the process must be known and perhaps adjusted for the WfMS to work.

When having a WfMS, the bottleneck of double administration can be dealt with. Personal details of the patient for example that are inputted can easily be copied in the WfMS and stored in the proper systems. It would be even better to just make references to places where certain patient information can be retrieved.

To maintain a good quality of care, clogging of patient data should occur. This can be prevented by building in fail saves. A failsafe could be that when a treatment is set up, the system request an appointment for blood research (if that is necessary). In section 4.2.1 push and pull mechanisms are discussed as a tool for building in fail saves. Administration rights can also be granted here. Not everyone who works on the unit should be able to alter or look in certain patient data. E.g. a receptionist should not be able to make alterations in the DRG (Diagnostic Related Groups, in Dutch DBC) system. That task is predefined for the gynaecologist. Before these rights can be granted, the differentiation of tasks should be made. Rights are granted to all the functions that are present on the unit. Before granting the rights to the function groups, the task differentiation must be at order. The differentiation of tasks should take place before implementing the new

system. A good point to do task differentiation is after the process analysis. When adjustments need to be made, possible alterations in task differentiation should take place there.

To what extent are the administration bottlenecks stated in section 3.2.4 solved? First of all the amount of administrative systems can be brought down. The number doesn't actually decrease, but virtually you can make “one” system. From this “one” system the user can access and input all the needed patient information. The solution will be more user friendly. Double administration activities can be filtered. That way data only has to be inputted once and copies can be made automatically to the right underlying HAD systems. This will save a lot of scarce time for the healthcare professional.

When arranging the WfMS, rules, routes and roles are predetermined. Rules can and must be set that the system retrieves the most up to date patient information when requested. The consistency of data can be guaranteed this way. Quality of care delivered to the patient is therefore improved. Furthermore the nurse or gynaecologist have more direct patient available. The direct patient time increases because the used preconditional patient time, such as administration, becomes less.

The informational architecture can gain a lot of efficiency on a unit such as Obstetrics. The right procedure, first make sure the processes are adjusted and the people are ready, must be followed.

4.2.3 Design process of the information architecture

In section 2.3 four main requirements for the design process of a WfMS of Klishewski & Wetzel (2002) are stated. According to them a WfMS must meet the following requirements: flexibility support, interoperability, customer orientation and agreement on the process. In the (Dutch) healthcare a lot of changes occur. These changes can take place in legislation, medical developments or in medical protocols for example. From that point of view it is necessary to have a WfMS that is flexible. Adjustments as result of changes have to be easy to be made in the WfMS. Otherwise the WfMS will clog up and will not function at an optimal level. The set up of the WfMS must be in such a way that adjustments can easily be made and overhead expenses can stay low.

Interoperability is a functionality that is strived by the WfMS. The specification of the WfMS must result in a situation were different systems can communicate with each other and information can be exchanged. These things occur behind the scenes, the end user should have one screen were all the needed information is displayed. The WfMS takes care that the right pieces of information are retrieved and stored at the right applications, taking care of interoperability.

Customer orientation is a very important requirement as well. When using a WfMS, the customer has to receive at least the same level of service as before the WfMS, but preferably more. The needs of the customer, the patient, have to be satisfied. The place to regulate the service for the customer is during the scrutiny and adjustments of the processes. The information architecture of this chapter states that the patient should have a central place in the process. From that perspective good service and quality can be offered to the patient. When the process is defined well, the patient will encounter less bothering factors such as unnecessary waiting times. Order Management (OM) can be used to organize the process even better around the patient. Using OM, the process will be even more organized around the patient. This will result in better service towards the patient. It could also result that the patient shouldn't have to wait unnecessary for the physician, for example.

The final point is the agreement on the process. Every actor involved in the process should be involved in defining the process. Their knowledge can be vital to the development of the process. Without the input of the actors with their different functionalities, it is difficult to generate a good process which can function as a basis for the WfMS.

In the information architecture all the requirements for the design process of a WfMS discussed by Klishewski & Wetzel are met. The design of the information architecture is therefore more solid, according to their requirements.

4.2.4 Extra functionality in the information architecture

Looking at the conceptual model just described, extra functionalities can be added to the information architecture. By adding other general functionalities the model can gain even more efficiency. An important functionality, which can be added to the equation of the WfMS, is Order Management (OM). The functionalities of OM are stated in section 2.2.3. Logistic management is also important. But logistic management can be seen as capacity planning, such as staff for an operation. Capacity planning is a part of OM, therefore it is discussed as a whole in this section.

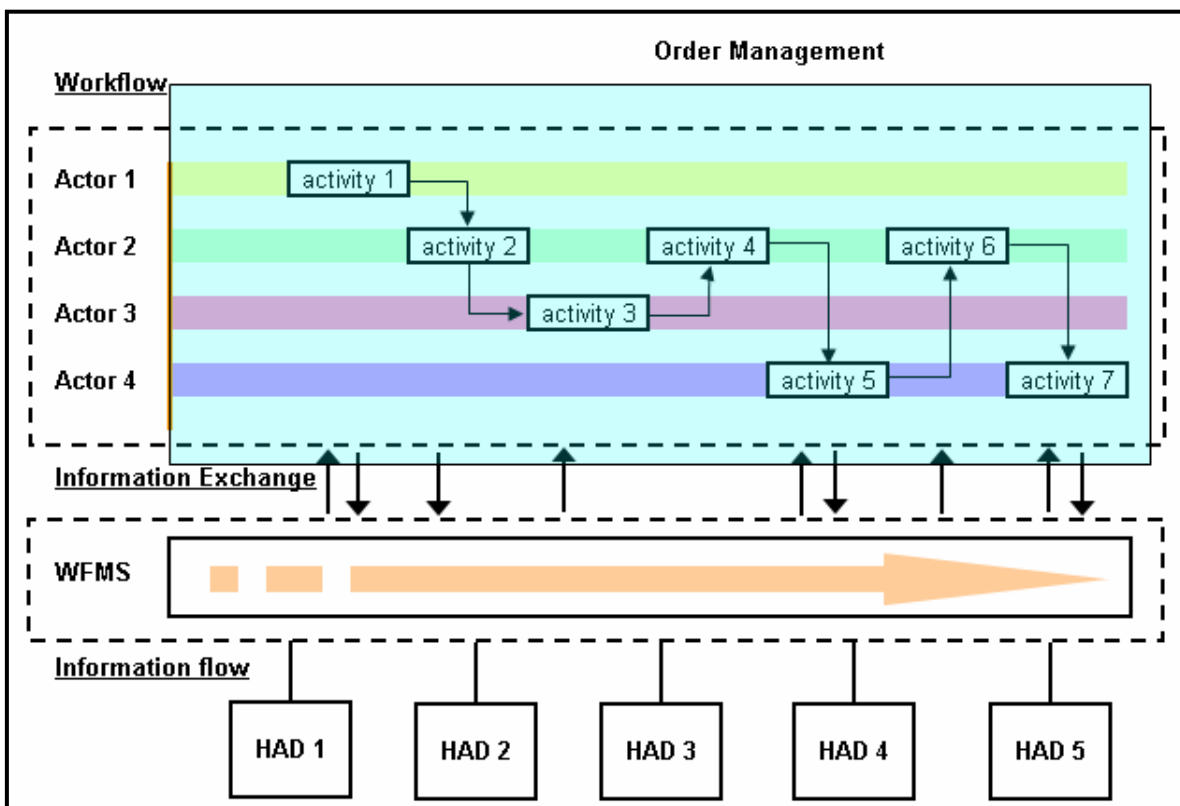

Figure 12: WfMS and Order Management

OM is placed on top of the activities within the model of the WfMS. OM takes care of the orders done in a single activity, not for the entire process at once.

First of all OM monitors the status of the patient in the clinical pathway. OM gives feedback of the result of an order to the original requester. OM plans the individual activities within the clinical pathway, which is done with order sets. In the clinical pathway decisions are made about

whether the patient can go to the next step/activity in the pathway. This decision is not made by OM. The clinical pathway exists of a lot of decision moments. That is why OM can't monitor the whole clinical pathway but just the individual activities with their individual order sets. A tool that can be used, when events run differently as planned, is decision support. With decision support additional or other activities can easily be made, founded by protocols.

On the other hand appointments can be generated by OM. For this to work a clinical pathway application is necessary. This application uses the functionalities of OM, but is must also guaranty the decision moments within the clinical pathway. A WfMS can be used as such a clinical pathway application. In figure 12 above, OM is taken into the information architecture. OM can be seen as a part of a WfMS. In the figure it is OM drawn as an overlying layer on top of the process. The opacity of the OM layer is used to emphasize that OM works on an individual basis on the different activities in the workflow.

In section 2.3 a bottleneck discovered by Klischewski & Wetzel (2001) is discussed. The healthcare providers don't have a clear overview of the status of the patient in the process. There is a lack of information that is needed to give the health care provider the information that is needed about the status in the process. At this moment this knowledge isn't available in the Erasmus MC, yet. OM can play a significant role to achieve improvement of this bottleneck.

When putting OM in the information architecture, figure 10 evolves. OM is put on top of the process layer. The intelligence within the WfMS divides the orders of the OM. OM monitors the individual activities in the clinical pathway. What is needed next is a person that is responsible for monitoring the process. This person should have a central and coordinating role in the process that the patient follows. In the process the physician mostly has a central role. This role is based on the fact that many decisions are made by the physician and the physician sees the patient on a regular base. Therefore the physician should be responsible for the monitoring of the patient in the process. Some of the responsibilities can also be given to e.g. the nurse when he/she has a central role in a part of the process and the role of the physician is of minor importance. Responsibilities on the responsibilities should also be worked out properly. Decisions should be made during the analysis of the process. This way the best fit for the process can be made on which all the involved parties can agree.

The WfMS can still function as stated before. The WfMS is supporting to the process, the clinical pathway. When arranged correctly with the process, it should function properly.

On the other hand there are a couple of disadvantages. When implementing OM, decisions about planning are made beyond the borders of the speciality. The Operating Room for example, is used by more different units and specialities. Laboratory researches are also done outside of the unit. In other words, other processes and other specialities are bound to cross lines with each other. This requires even better fine tuning and development of processes. Making use of OM brings more complexity, because more agreements and especially agreements beyond own borders have to be made. On the other hand, when done properly many benefits can be reached.

When implementing OM one feature has great importance. That feature is having one interface. One clear interface is necessary for the healthcare professional in order to work well with OM. Monitoring otherwise becomes more difficult, which has as disadvantage that people don't like to work with it and look for a way to work around the system. The utility for one interface to work with is acknowledged by many people within the Erasmus MC.

4.2.5 Data Criteria

In section 2.3 a set of Criteria for a WfMS, by Grefen (2001), were discussed. These criteria set out what kind of data is needed to create a successful WfMS. Let's take a look at these criteria again to find out if they comply with the stated information architecture described above. The criteria were: process specification, organization specification, information specification, situations in current cases and historical information.

When talking about the process specification, it comprehends the extensive description of the workflow/process. The organization specification is about describing the different rules, routes and roles that exist within the workflow. It gives a description about functions, tasks and actors for example. These two criteria are met in the information architecture or ICT of the supportive solution. The needed information for these two criteria is collected during the process analysis before the WfMS is specified. At that point the specification of the information flow also takes place. In the information specification of the information flow is presented within the WfMS. So this criterion is also covered. Historical information is not well known in the case of the Obstetrics unit. Management Information (MI) is not retrieved from the inputted patient information. However the possibility of aggregating MI is present, but is unknown by the people and not used. MI needs predefined criteria to work properly according to the wishes of the users. These criteria should be defined during the design of the WfMS. On this moment historical data doesn't contribute to the development of specification of the information flow. Current cases on the other hand can be used as a reference more insight in the process. They can help giving more insight in the context of different situations in the process. These situations should come forth when discussing the process in order to optimize it.

Concluding, most of the criteria by Grefen are met by the information architecture. The criterion of historical information isn't fully met. Historical information can't be used because it is not aggregated as MI, yet. This function, on the other hand, should be defined in the WfMS. The stated criteria are therefore all met in the information architecture.

4.3 Conclusions

At the end of chapter 3, the main bottlenecks were stated. In section 4.1 these bottlenecks were further discussed. Within the framework of working towards a solution, solutions for these bottlenecks firstly were discussed without looking at the support of ICT. They were discussed from the perspective of processes and people. In section 4.2 ICT was involved for working towards a solution. The question is whether the main bottlenecks can really be solved by the ICT solution, the WfMS?

1. Alignment of processes and ICT

When applying a WfMS, the first step taken is scrutiny of the processes. When processes aren't scrutinized, a WfMS can not be developed. Alignment of the processes and ICT, within the WfMS, is a precondition. Therefore alignment will be secured within the information architecture.

2. Involvement of different actors

The decisions about the needed ICT are made at the wrong level. The people who have to work with the system have little influence on the decisions of the specifications. This problem can also be solved by a WfMS. When defining and adjusting the processes, all the different actors have to be involved. The different actors can certainly bring input there. As a result they can have their influence on the arranging of the WfMS as a whole. When the procedure is followed properly, all the different actors should be satisfied with the end result, because it is built on their perceptions.

3. Inefficient administration

A WfMS can solve a lot of the bottlenecks experienced by that topic. The solution, the WfMS, for a lot of the administrative bottlenecks is discussed in section 4.2.2. A WfMS can solve a lot of these points. But this can rather be tricky. It will only bring a solution when rules, routes and roles are defined before the development of the WfMS. Agreements must be made about where (vital) information is stored and how the labelling of the latest inputted data takes place for example. These subjects must be defined at forehand. Only then can efficiency be obtained and can the bottlenecks be solved by implementing a WfMS.

4. Management information

When defining the administration related topics, Management Information should also get attention. At that stage conditions for outputting MI can easily be arranged. When the WfMS is operational, MI can bring many benefits to a unit. For an optimal efficient effect the unit should make the definitions also with central management. The decentralized MI, can also be used for central input. The difference in data about the unit should then be a thing of the past.

The implementation of a WfMS should solve the four main bottlenecks. The criteria for the needed data by Grefen, discussed in section 4.2.5 and the criteria for the design process by Klischewski & Wetzel, discussed in section 4.2.3, are also met. A WfMS can probably function as a good organizational basis to solve other bottlenecks as well.

Chapter 5: Feasibility of the Solutions

In this chapter the feasibility of the solutions of the bottlenecks, that were put forward in the previous chapter, are discussed. Different actors were interviewed about the feasibility adjustments stated in chapter 4. Retrieved feasibility by doing interviews also is of use as a validation of the architecture proposed in section 4.2. This chapter retrieves whether the different actors can find themselves in the concluded bottlenecks. Furthermore it discusses whether the proposed solutions hold for the future or need adjusting. When this is necessary recommendations about adjustments are given.

5.1 Set up of the Interview

When stating the necessary adjustment and the information architecture in chapter 4, little was said about the feasibility. To validate and test the feasibility, interviews with different actors took place. From the ICT department two people were interviewed, one responsible for Consultancy & Software Engineering and the other for Maintenance & Information System Management. From the Obstetric unit two nurses and a gynaecologist were interviewed. The people from the Obstetric unit were selected because they play a significant part in the process that was analysed. Their role is supervising on their area of expertise. Therefore they have the knowledge to take a closer look at the solutions and the proposed information architecture. The interviewees from the ICT department were selected because of their function and expertise. One of them is responsible for the maintenance of the systems. This gives a good insight in the way ICT is organized within the Erasmus MC and at the Obstetric unit. The other interviewee is an expert on software engineering which gives an angle on looking at the feasibility of the information architecture and scrutiny towards processes. These actors all play a role in the solution of the bottlenecks described. Input from these different actors is necessary to retrieve the different views each actor has on the bottlenecks.

The basis questionnaire used during the interviews is stated in appendix 7. The questionnaire is composed in such a way that all the bottlenecks are discussed and the solutions tested on their feasibility. The questions asked were open-ended questions. The reason for this was to give the interviewees enough space for telling their side of the story. The technique of “probing” was used to retrieve more elaboration and background information on a certain topic when needed. (Babbie 2007) Additional and more technical ICT-related questions were only asked to the interviewees of the ICT department.

The interviews duration was approximately 45 minutes to an hour. The interviews were all recorded. This way the quality of interviewing was better. Quick responses to answers and further questioning were possible and distraction caused by writing the answers down was reduced to a minimum. Afterwards the interviews, and some little notes, were worked out.

Besides the interviewees stated above, the CIO and a process specialist of the “Ruimte voor Nieuw” project were also interviewed during an earlier consultation.

5.2 Recognition of the bottlenecks

In this paragraph the main bottlenecks, as stated in section 3.3 and section 4.1, are discussed from the viewpoint of the interviewees. The question is whether the bottlenecks are recognized by the

different actors in the practice. Another aspect retrieved is what the origin of these bottlenecks is and what should be done to resolve them.

5.2.1 Alignment of processes and ICT

The bottleneck of the lack of alignment is recognized by all interviewees. From the interviews it appeared that ICT applications are often implemented on an ad hoc basis. The start of an ICT project begins with a demand from the medical staff for a certain automated functionality. The ad hoc character is caused by panic. This is because they think they should need it right away and problems will occur when not implemented quickly enough. When the demand is solved by the ICT department the peace on the unit is usually quickly restored. The ICT department refers to this as extinguishing fires, meaning that the somewhat panicked demand must be resolved quickly in order to keep the customer satisfied.

The nurses and gynaecologist also emphasise the ad hoc character of the demand for ICT applications. The necessity for aligning the process with ICT is acknowledged. But for getting good alignment other units also have to be involved. They think achieving better alignment will be more difficult, because units rarely look outside their own profession.

As a result decisions made on ICT have an ad hoc character. A general vision for the middle long term on ICT implementations does not exist, yet. Plans to set up this vision in the near future are made at this moment. These plans will be done on basis of a clear process analysis defining the patient flow, information flow and the involved actors.

The ICT department also observes a lack in realisation of the importance of a process analysis by the units. The basis for a process analysis is very small. The ICT department sees it as their task to improve this basis. But in practice this isn't always easy. Eventually the unit itself is responsible for making a basis for a process analysis. When a unit doesn't see the need for a process analysis, “than that's the end of that story”. Because of little time and budget, the effort from the ICT department to make this basis can't be indefinitely. The ICT department also sees itself in a role as rendering a service which is facilitating to the process. Their primary task is to meet the requested demand of the “customer”. The demand must be initiated by the customer itself.

The two interviewees from the ICT-department said that ICT is supportive to the existing processes. But they didn't know exactly in what extend process analyses normally took place. “The customer is always responsible for doing process analyses herself, but it is not always clear if this is done and if they are done properly”, was the response.

Good process analysis at the beginning of the project can help ICT attune better to supporting the process, according to the ICT interviewees. The process analysis must be thoroughly thought, more thorough than a process analysis that is used for Business Process Redesign. The thorough process analysis is needed to prevent “surprises” and flaws, in patient specific cases. You don't want to discover flaws or lacks in requirements when the application is already implemented. At that point adjustments are harder to make and are more costly.

The reason the nurses and the gynaecologist give for not looking at their processes is lack of time. In their schedule they don't have time available for other activities besides their normal activities.

Concluding this section the following can be said on aligning processes and ICT. Demands on ICT, from the medical staff, are done on an ad hoc basis. The ICT department responds quickly on these demands. As a result alignment between the process and ICT is not good. The *medical*

staff is responsible for the specification of the ICT requirements and for the process analyses, according to all the interviewees. This sometimes has negative effects because the oversight of the medical staff about the primary process is limited. The ICT department does not have a clear oversight about the quality of the process analysis. ICT department sees itself in a conflicting role at this stage. On one hand they find themselves responsible for creating a good basis for process analyses. On the other hand they are only rendering a service to a customer, in which case they assume the process analysis is complete. Without a long term vision of the customer with less ad hoc demands, coordination from the ICT department and the uncertainty of having a good process analysis, alignment is not good.

The coordinating role of the ICT department must be bigger. They must oversee that the process analysis done, is thorough enough and of high quality. The medical staff must make a more long term vision. This long term vision is needed to fore come “ad hoc” demands. Furthermore must they expand their knowledge about what exactly is going on in the primary process of their unit. This recommendation leads us to the next bottleneck, the involvement of actors.

5.2.2 Involvement of Actors

What is seen often in the unit, and in the hospital as well, is the lack of involvement of different actors when making decisions about ICT. What happens is that the medical staff, which are responsible for the project, don’t use the knowledge of all the different actors provided. The medical staff has some oversight limitations on the primary process, as stated previously. This bottleneck is recognized by the interviewees and emphasized by the nurses and the gynaecologist. The interviewees of the ICT department acknowledge the importance of involvement of different actors in an ICT project. Feedback from all levels of the unit is absolutely necessary. That information is the basis for the application and is used as feedback during development.

Implementation and acceptance of an application can be a problem when the operational level of the unit wasn’t involved in the project. The ICT department strongly advises to involve all different actors. The unit management and the medical staff are responsible for organizing their project team. The ICT department can only give advice about it and nothing more. Groups of actors were sometimes neglected by the unit management and medical staff, which had negative impact on implemented ICT projects. The surplus value of involving different actors is acknowledged more and more nowadays.

The nurses emphasise the ad hoc character of implementing ICT for accounted problems again. The problem is that sometimes an application is implemented without them knowing at all. Most of the time nurses aren’t asked to look or think about an application. Decisions were made higher up without consultation beforehand. This can lead to a lower satisfaction on the work floor. An example of this problem was when the new section of the child hospital was built a couple of years ago. The medical staff made all the decisions without consulting the actors of the primary process. This resulted in too small doors on the unit. A normal bed fits nicely trough the doors, but sometimes pumps and other medical equipment are attached to the bed. This neglected aspect resulted in a lot of difficulties, because a bed must be stripped of medical equipment before fitting the door. The nurses feel that they could have helped preventing these flaws when consulted at an early stage. They think the same applies for the implementation of ICT applications.

What happens at this moment is that different actors are involved by making alterations and giving practical feedback in an already implemented application. A complaint from the nurses and gynaecologist is that feedback lines aren’t as good as they should be. The situation is that one

representative of the nurses gives feedback to someone of the management staff of the unit. This person gives the feedback to the medical staff. The gynaecologist gives his feedback directly to the medical staff. What occurs is that little discussion on the topics before decisions are made by the medical staff. Purely because the medical staff thinks that they know what is best for their unit.

Another point of criticism is that when actors are involved, little time is reserved and available in their normal schedules. This point is also stated in the previous section. The nurses and gynaecologist think that feedback can be much better if different actors who participate in a taskforce have more time reserved. In their opinion the quality of feedback will be much better that way.

In conclusion all interviewees agree that there is a lack of involvement of the actors. Not every actor (function) is involved during a project. This can lead to problems at the implementation stage or for acceptance of the application. The ad hoc character is responsible for not involving all the different actors. Another point is that the involved actors don't have enough time to give their contribution to the project. Their daily schedule does not let them do other activities than that their function requires of them to do.

The unit is primarily responsible to involve the right actors in the project. But this does not always happen. (In section 5.3 this point will be discussed further) Therefore should the ICT department help with or coordinate involving the right actors in the project. Reducing the ad hoc character of these projects should also result in a better oversight of the involvement of actors and creating a basis for the project on the work floor. The final recommendation should be about creating more available time for the involved actors to bring their input.

5.2.3 Administration

In previous chapters the amount of applications used for administration was discussed. A question about the administration asked to the interviewees is why there are so many standalone applications.

The declaration of the ICT department for the existence of many standalone systems is the historic growth of the Obstetric unit, which also is the case in other units of the Erasmus MC. The historic growth of the Obstetric unit arose from “ad hoc” demands. When certain functionalities were needed, the ICT department responded and an application would be implemented. Such applications have a great functionality on their demanded subject, but their scope is limited. Most applications only execute the specific functionalities requested by the gynaecologists. For the gynaecologist this is perfect. Physicians in general have a very narrow vision about the functionalities of the applications. They don't look left or right or at the process. They focus on their speciality and on helping the patient. As a result by responding on ad hoc demand, redundancy can easily occur. The ICT department only acts by demand of orders given by the physicians. The ICT department does not feel responsible for factors such as the best fit with the process and redundancy of data. This is something that the “customer” is responsible for. The ICT department doesn't have the time, knowledge and money to look further and deeper and don't see it as their responsibility to do so. In the end this structure has led to the different monoliths which are present on the Obstetric unit.

The reason nurses give is that there is little money. Everything has to be as cheap as possible. This observation is also affirmed in the employee satisfaction research (MTO). The available resources are experienced as slim by the employees. Solutions are all based on a short term vision. The ICT “jungle” that exists at this moment, results in resistance on the work floor. Decisions are also made without a good consultation with the people of the primary process. At this topic a paradox exists. The medical staff lacks oversight of the primary process, but still makes all the decisions for it. The most important thing is that an end product must be reached inherent to the satisfaction of other actors. Involvement of the medical staff should also concentrate more on making a basis on the work floor which is necessary for an ICT project to succeed, according to the interviewees.

Another problem that enhances the existence of more different systems, are the software providers. What you want on a unit are the specific functionalities that are of use. The rest around that functionality can be thrown away. Commercially seen this often is impossible. The supplier of the application doesn’t want to sell that specific functionality. Software providers want to sell the whole application which earns them the most money. Eventually the whole application that is offered is actually excellent, but when executing more comparable applications ICT grows uncontrollably. This of course has a negative influence on the occurrence of redundancy.

What can be concluded is that historic growth is responsible for the amount of stand alone applications. A negative effect is that redundancy occurs. The existing paradox about the fact that the medical staff makes all the decisions without having a clear oversight will be discussed further in section 5.3. What is clear is that some adjustments in the decision structure must be made.

The goal of ICT projects must be more focussed on a good result instead of getting an end product. The role of the medical staff should also be more focussed on creating a good basis for the project on the work floor. Having a good basis for an application helps coming to a good result of the project. The ICT department should be more focussed on preventing the existence of redundancy. This should be done together with the involved actors and their knowledge. From the software side, integration of systems should get more attention. If integration cannot be reached, perhaps looking at new systems where all functionalities are present can be interesting.

5.2.4 Management Information

On the subject of Management Information (MI) the question was asked why there is such little use of MI in general.

The nurses responded that the need for MI is low at this moment. On the other hand they think that it could be useful. From within their profession little is done thinking about useful points that MI could generate.

The gynaecologist said that it is too difficult to retrieve MI. The gynaecologist prefers to keep up MI by using paper documentation. This paper documentation needs to be imported in an Office application to generate the needed MI.

The ICT department claims that realization of MI in general is very low. Previously the emphasis of MI was focussed on financial and administrative activities. But the focus is transferring towards medical information. At this moment MI is actually available or can be generated without much effort. Realization is necessary because MI works from a demand not a supply. The ICT department will only generate MI if asked to.

Awareness within the unit for using MI should be created. This should be done by the management of the Cluster. They should have all the necessary information for creating MI. Awareness should be created on all the different levels. Each level has different wishes about MI. The ICT department can help delivering MI when asked and can help developing new requested MI.

5.3 Decision structure

Based on the feedback of the interviewees, this section enlightens another bottleneck where adjustments are necessary. This bottleneck is stated in a new section. The reason that it is not stated in the previous section is because this bottleneck was concluded from that section.

The main bottlenecks discussed in this thesis were the lack of alignment of ICT and processes, the lack of involvement of actors and the vastness in ICT systems. These bottlenecks must have a cause that lies within the culture of the Erasmus MC. During the interviews with the different actors, this cause became clearer. The cause of the main bottlenecks lies within the decision structure used for ICT. The bottlenecks in this decision structure are concluded from the previous discussed bottlenecks and the interviews. The bottlenecks of the decision structure are:

- decisions are made by people who don't have a clear overview of the work floor;
- lack of involvement of different actors with different functions during decisions;
- the ICT department's primary task is to respond to the requested demand;
- responsibilities about project tasks are ambiguous;

The current decision structure must be adjusted on the following points.

- *Decisions must be made at the right place.*

This automatically means that the decisions are made by the right persons. At this moment the medical staff makes all the decisions. The medical staff lacks good oversight of the work floor, as been discussed earlier in this chapter. The knowledge of the medical staff is mostly on the tactical and strategic level. The knowledge on the operational level is much less. Their interest also differs from the other actors. The primary task of the medical staff is about research and education. These are the factors they will be judged upon at the end of the year. The physician assistants are the ones that are mostly responsible for giving care to the patient. The incentives of the medical staff differ much from the incentives nurses or physician assistants have. Decisions are influenced by the role and incentives of the decision maker. A clear structure for the levels of decisions is therefore necessary.

To make a clear structure for making decisions, the unit must be divided in three different layers of decisions. With unit the organizational elements which are involved in a project are meant. Two or more units from the same cluster or from other clusters can be involved. These layers are based on the levels of management. Decisions must be made on an operational, tactical and strategic level. By making this categorization, different actors can be classified on their specific area of knowledge. The goal of this structure is that decisions are made by the actors who have the best knowledge within a certain layer.

- *ICT knowledge is necessary*

At this moment the ICT department finds themselves solely responsible for the executions of the demand by the customer, in this case the unit. The unit experiences this as well. During the

interviews the nurses and gynaecologists said that a more intense cooperation with the ICT department is desirable. The relations between the ICT department and the unit, resembles a principal/customer relation. This relation must be transferred to more of a team relation. This can be reached if one or more representatives from the ICT department, depending on the situation, should be present at the different management layers. The structure is displayed in figure 13 below.

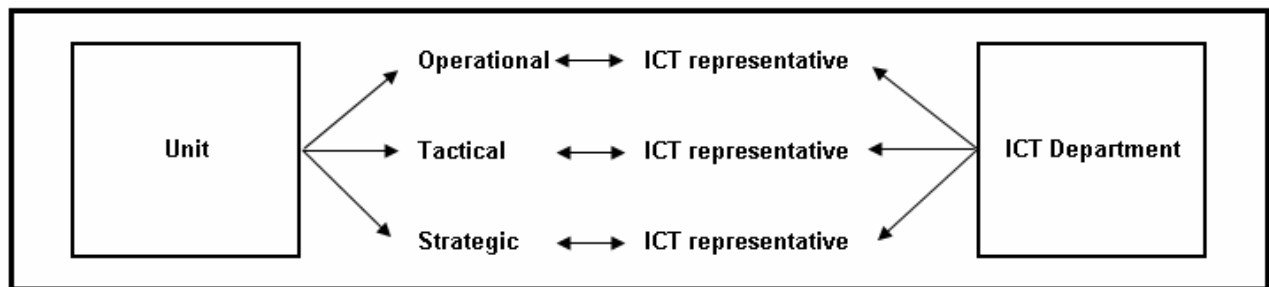

Figure 13: New Decision Structure

Decisions must be made on three different levels. A representative of the ICT department is present at each of these levels. A mediator can be put in the middle between the different layers of the unit and ICT department.

From the wish for of a situation to have more cooperation, another desire underpins the need for more cooperation. This other desire can be concluded from the interviews. What actually is needed is a mediator/middleman. This middleman should give advice on the business level of the unit. The middleman can be seen as an information manager. This function requires that mediation between the different management layers takes place and that the functionalities of the system are specialized. The middle man can take place in the middle of figure 13, where at this point the connection arrow is drawn.

The result of this structure must be that the quality of consultation and the focus is improved. The advantage is that the execution lines are shorter and results can be achieved sooner. As a result of this, the people will experience more involvement of the ICT department. This experience can influence the creation for a good basis for the ICT implementation. The shared responsibility for the succeeding of the project will enhance each other.

For this new decision structure to function properly, another adjustment has to be made. This adjustment should be done at the extend of available time of the involved actors. During the interviews this problem became apparent. The involved actors don't have time reserved in their schedule to do other activities, such as taking part in an ICT implementation project. As a result their input and commitment isn't as high as it could be. Therefore more time must be reserved in their schedules so they can provide their input. When time for projects is reserved consultations and other work can be done better and much quicker than usual.

The end result of adjusting the decision structure is to gain efficiency. The gain is due to better knowledge of the decision makers, at the right time and with more commitment. This requires the involvement of actors. The medical staff does not have oversight on the operational level, but does make decisions for it. The structure of decision making must be divided into the three management layers. This way decisions are made by the actors who have the best knowledge of

their layer. The relationship with the ICT department must also change. The character must be more about cooperation with each other instead of a principal/customer relation. The ICT department can act as mediator between the management layer of the unit and with their own project group. This must also result in a general oversight and not just on a split up of the project into the layers. For this to work the people have to change and the involved actors of the unit should have enough time available in their schedule to bring good input in the project. Without that changing the decision structure will not result into the required result.

5.4 Feasibility of a WfMS

In this paragraph the feasibility of a WfMS as a solution is discussed. The discussion is based on the responses of the interviewees.

In an ideal situation, all the interviewees respond that integration of all functionalities in one system or one graphical interface is desirable. The question is if such integration is feasible in the Erasmus MC.

One of the first points responded by the interviewees is the importance of the user. The user is responsible for the success of the project. For the WfMS to be a success it must be user friendly. One aspect is that all necessary information is displayed for that certain type of user. Another aspect is that the WfMS should be easy to use. In the previous section the example of the preference of a paper sheet above a computational application was given. A user doesn't want too much interaction with the program, e.g. the lesser “clicks” are needed the better. The application must work easier for the user than a pre-printed standard form. This is one of the difficult tasks for the ICT department to achieve. The revenue of using a WfMS must be a reduction of time or a reduction of costs in general. Otherwise the chances of success are very slim.

One of the requirements is that the system must be flexible, according to the interviewees. All the interviewees emphasise the changing character of health care and organizational change which influences the units in the hospital. A WfMS and OM can only function well if it can adapt to changes in the environment. Configurations also have to be made to fit the specific unit. Therefore the WfMS must be easy and continuous adaptable to give the best fit for the current situation for the unit.

Other than pleasing the user as much as possible, more complex matter influences the WfMS. First of all the logistic complexity of the Erasmus MC is very big. In comparison with a normal periphery hospital, the locations where blood samples are taken can be counted on one hand in a normal hospital. In the Erasmus MC there are up to 80 locations. A normal hospital usually has one or two laboratories, the Erasmus MC has 28 laboratories. In the situation of the Erasmus MC it is much harder to implement a WfMS or OM than in a normal hospital. The technical feasibility of the WfMS can therefore be very difficult.

Another complex characteristic of the Erasmus MC is the hierarchy. Some of the hierarchy lines are experienced as not logic. Most actor groups have their own speciality. Within their speciality the actor groups try to defend their status quo. This makes it harder to implement an application that focuses more on the long term view where cooperation between specialities and actor groups will increase.

The question if the proposed information architecture of section 4.2 could work in practice was asked to the interviewees from the ICT department. They thought the presented architecture is a good solution, in theory. They think it will be very difficult to work the architecture out on a technical level. One of the reasons they give is the complexity of the organisation, discussed above. The presence of politics, different hierarchy levels and the difference in expectations of actors also has influence on the realization of proposed architecture. The third reason is that the organisation should be ready for it. On this moment they think the organization isn't ready for it yet. When the organization isn't ready, it will be more difficult to create a basis for the architecture. At this point in time there is a discrepancy between the capabilities of the application and the capabilities of the users. The capabilities of the users in the Erasmus MC are behind of the capabilities of the WfMS comparable applications. If a too large gap exists between the capabilities, the users become dissatisfied. Little steps need to be taken. With each step growth is realised. The interviewees of the ICT department claimed that it will not be possible to implement an extremely good application in one step. The biggest problem is the immature state of the culture within the Erasmus MC. When wanting too much, people are pushed in the opposite direction which could result in returning to use paper instead of the application.

In conclusion, for a WfMS to work is must be suffice on the following requirements.

- It must be easy to use, otherwise the users will work around it.
- It must also be user friendly for the same reason
- It must reduce costs or reduce the time spent in comparison with the previous situation
- Functionalities must be integrated
- The WfMS must be flexible so it is able to adapt easily to occurring changes

Looking from a technical point of view, the feasibility of the WfMS is not so easy to achieve. This is due to logistical complexity, complex hierarchy and the lack of readiness and capability of the unit and the organisation. These factors make it hard to implement a well functioning WfMS. A good solution to resolve these underlying factors that influence the technical feasibility is not easy to accomplish. These factors are within the roots of the organisation. For them to change Business Process Redesign would be necessary, also with a growth of readiness and capability of the employees.

Chapter 6: Conclusions, Recommendations and Further Research

6.1 Conclusions

The research in the Erasmus MC began with the DMO (efficiency) researches at the Obstetric unit. From those researches a lot of data was returned. With this data further scrutiny was done. From that scrutiny some interesting results came forth. This led to the conclusion of four main bottlenecks and was later on supplemented by another bottleneck.

The red line through this thesis is the way people, processes and ICT are intertwined with each other. When changes are made in one factor, the other factors are influenced by it. One of these factors can also be an enabler for another factor. Before the central research question is discussed in section 6.1.2, the bottlenecks are discussed first.

6.1.1 Bottlenecks

1. The first main bottleneck is the *lack of alignment* of the processes with ICT solutions. At this bottleneck there is a lot of ambiguity about the responsibilities of integrating processes in an ICT project. The main responsibility for aligning processes with ICT and involving processes lies within the unit. This task is the responsibility of the management and medical staff. This responsibility must also be taken in the future, otherwise aligning processes and ICT will be difficult.
2. This bottleneck is about the *lack of balanced involvement* of all actors. Decisions about ICT are made by the medical staff. The medical staff does not have enough oversight to make the best decisions about e.g. specifications. Other relevant actors who can bring up usable input, such as nurses, are neglected. This results in a lower basis for the ICT implementation, inefficient organization and usage of the application and a lower satisfaction on the work floor. For a good inventory and scrutiny of the processes, involvement of all different actors is necessary. Their input has an important contribution for the success of the application. Knowledge necessary for making decisions must be available on operational, tactical and strategic level. When this bottleneck can be solved, it will also have a positive influence on the alignment of processes and ICT. The people can be an enabler for better alignment between the processes and ICT.
3. The following bottleneck is the *false position of the decision structure*. This bottleneck became clear at a later stage of the research, mostly during the interviews. Decisions are now made by the medical staff. The disadvantage they have is that they lack a good oversight of the primary process. Their knowledge is better on the tactical and strategic levels of the unit. In combination with the second bottleneck this results in non optimal decisions about ICT. A clear structure for making decisions is necessary. The decision structure must consist of three layers, the strategic, tactical and operational layer. The different actors with their different area of knowledge are categorized in such a way that decisions are optimal knowledge supported.
4. The fourth bottleneck is the *inefficient organization of administration*. The Obstetric unit uses a lot of systems for administration and to look up patient information. Tasks between functions and workloads are shifting. This shift is not taken

into the administrative process which has evolved on historic grounds. As a result the organization of the administration process is not good. The different applications communicate poorly with each other. As a result of that redundancy of patient information occurs. Redundancy causes double administration of patient data and brings less clarity about the where the most up to date patient information can be retrieved. A solution for this bottleneck is to make good agreements. Agreements must be made about the way of working so that redundancy is reduced and the reliability of information increases.

5. The last bottleneck is about the *non-usage of Management Information (MI)*. With MI efficiency can be gained, e.g. for a better usage of available capacity. When a fair amount of administration of patient data is done, the low usage of MI wasn't expected. The most important factor of not using MI is the unawareness of the people working at the Obstetric unit. For a better use of MI, awareness must be created. Other than that, agreements must be made about which MI should be generated for use. Registration of the required data must be assured, otherwise mismanagement could occur which results in useless MI.

6.1.2 Positioning of WfM

In the beginning of this thesis the central research question was stated. The question was:

Which contribution can WFM provide to optimise health care in the Erasmus MC?

Before the WfMS information architecture can be implemented, which is stated in section 4.2.1, a couple of requirements must be met. First of all besides the workflow, the information flow must also be known. Second, all the actors that have a role within the workflow must be known and appointed. Finally the patient must have a central role. The WfMS is based around the movement of the patient in the healthcare process. But what is the contribution of WfM in the form of a WfMS to optimise health care in the Erasmus MC? When the four main bottlenecks can be solved, patient care should be optimised.

Process Scrutiny for alignment with ICT

To arrange a WfMS in an optimal manner it is necessary to have done a very thorough process scrutiny. From this scrutiny the design is made. In this design all redesign issues must be taken in. The new design must also be the result of a collective agreement. The same requirements are needed for the information flow. If scrutiny isn't done thorough enough, problems on the long run will occur. The process scrutiny is the basis for a good fit between ICT and the process itself. Eventually the workflow and the information flow will be joined in the WfMS. Improvements of aligning the process with ICT will be better due to the WfMS. Good scrutiny of the processes is an important and necessary requirement of the WfMS.

Within this project the role of the ICT department must be as supervisor. The ICT department has to make sure processes are scrutinized extensively enough. The unit itself stays responsible for the scrutiny of the process and must take their responsibility in it. The supervision of the ICT department will secure better alignment of processes and ICT.

Balanced involvement of all actors

When doing the process scrutiny, balanced input from the right actors is also necessary. Before beginning with the scrutiny the right actors must be selected for giving input of their special “know how”. At this moment the medical staff is mostly responsible for bringing input. Their “know how” is more based on the strategic and the tactical knowledge, but they also make decisions for the primary process of the unit. For good decisions from all the different layers a split must be made to operational, tactical and strategic level. When having this construction the right actors can be involved easier. The WfMS requires an extensive scrutiny of the processes. Therefore a balanced involvement of the right actors is necessary. Indirectly the WfMS takes care of better involvement of the right actors. But in the present context this would probably not work perfectly. Therefore the proposed adjustment in the decision structure is necessary to make sure this happens and that the actors with the best “know how” are responsible for making decisions on their level of expertise.

Administrative bottlenecks and Management Information

A WfMS also requires a set of rules, routes and roles. This set is related with the (administrative) applications. It’s important that the set of rules, routes and roles result in as little redundancy as possible. Furthermore it is possible to set rules about the fact that the WfMS always retrieves the most up to date patient information, so the gynaecologist doesn’t have to search anymore. The rules, routes and roles have to be set at the beginning of the WfMS development. They have to be set during the process and information flow scrutiny. The set up of these requirements can only be successful when the previous bottlenecks are solved. Good alignment between the processes and ICT is necessary and the right actors have to be involved. Decisions and input must also be done by the right people, emphasising the necessity of the new decision structure.

When arranging the set of rules, routes and roles, requirements about the use and arrangement of MI can also be made. The same arguments apply as discussed by the previous point about the set of rules, routes and roles. When setting up these requirements at an early stage, they will be easier to implement and to generate. Modern WfMS’ such as Soarian from Siemens already have the functionality for reporting implemented in the system.

Conclusive

Looking closely to the WfMS, it actually can solve all the main bottlenecks. But this is all in theory. Practical requirements are also needed. For starter the WfMS needs to be directed well. This must be done by the unit itself. The ICT department can help support the unit. Other than to direct the WfMS, commitment and agreement on decisions are also necessary. This must result in a clear framework of the WfMS, which is necessary for the WfMS to work.

Eventually the WfMS is only facilitating to the health care activities. ICT isn’t the solution that can change everything. The people, or culture, have to be changed first before ICT can be successful. In this case the decision structure must be adjusted for the previous stated reasons. Then the people will be an enabler for a successful development and implementation of the WfMS.

6.2 Recommendations

In this section recommendations for improvement are discussed. The recommendations are the result of the experienced bottlenecks and the feasibility of the WfMS.

- *Alignment of processes and ICT*

When discussing the alignment between ICT and processes the following recommendations can be done. First the balance between centralized and decentralized decisions must be clear. The framework must be made on a central level. On a decentralised level this framework can be worked out further. Decisions on the decentralized level can be made autonomous, but these decisions must fit within the central framework. Second the coordinating role of the ICT department must be bigger to assure better alignment. Thoroughness and quality must be guaranteed. This guarantee can best be given by the ICT department, because they have the best oversight on the project. Alignment of ICT and processes can only be achieved when the “ad hoc” character of making decisions by the medical staff is reduced or eliminated. What is needed at last is a long term vision that is born by the medical staff and de unit management. In that long term vision ICT should play a significant role and of course aligning the health care activities of the unit.

- *Involvement of actors*

A balanced involvement of the right actors within the project is the task of the unit. This is not always done. Decisions should not only be taken by the medical staff, which is the case right now. They do not have complete oversight of the primary process. Using the adjusted decision structure, this must assure that more actors are involved in the project. The split up to the layers of operational, tactical and strategic decisions must assure that decisions are made by the involved actors who have the best “know how” of their specific area. The role of the ICT department should be coordinating. They must oversee whether a balanced set of the right actors are involved in the project. From their role in the project it is easier to encourage better involvement of actors. The final recommendation should be about creating more available time for the involved actors to bring their input.

- *Decision structure*

Adjusting the decision structure is necessary to gain efficiency. As explained in section 5.3 the decision structure must be divided into an operational, tactical and strategic layer. This way decisions are made by the actors who have the best knowledge within their layer. The relation with the ICT department also has to change to function within the new decision structure. The relation must be of a more cooperative character instead of a customer/principal relation. The ICT department can also act as mediator between the management layer of the unit and with their own project group this way. The result must be a general oversight on the project by the ICT department and not just on a split up of the project into the layers. For this to work, the most important change must be made by the people. They are the enabler for change.

- *Administration*

A good basis for ICT projects must be the responsibility of the medical staff. They have the power to enthuse the work floor for the project. The goal of having a good basis is necessary is to lead the project to a good result, where resistance is reduced to a minimum. Reducing redundancy should be in the focus of the ICT department. They have better oversight on how ICT works behind the end user screen. Together with the involved actors redundancy can be reduced. The actors possess the practical knowledge about how many times certain data is actually inputted in the systems. Integration of applications should be a spearhead of the ICT projects in general.

- *Management Information*

Awareness within the unit for using MI should be created. This should be done by the management of the Cluster. They should have all the necessary information for creating MI. Awareness should be created on all the different levels. Each level has different wishes about MI. The ICT department can help delivering MI when asked and can help developing new requested MI.

- *Feasibility of the WfMS*

The technical feasibility of the WfMS is hard to achieve. Complexity exists in logistics, hierarchy and the lack of readiness and capability of the unit to work with new technology. These factors have to be resolved before a WfMS could function well. To achieve these changes organizational change is necessary. This is a very drastic mean. Business Process Redesign could help to achieve the organizational change. The downside of BPR is that it has a great impact on the organization. The question then will be whether the benefits will be higher than the “costs” and effects.

6.3 Further research

One of the first activities that were done when doing a master thesis, or any other kind of research, is narrow down the field of research. As a result other interesting research topics stay behind. During this thesis other ideas of study also came forth. These ideas derived from topics outside of the narrowed down field of research. Other than that new ideas arise from the master thesis as well. In this paragraph further research is discussed from three points of view. First further research by the RvN (Ruimte voor Nieuw) project is discussed. Then further research as a result of the main bottlenecks is discussed. Finally further research of the information architecture is proposed.

6.3.1 Generalization

First of all I would like to discuss the generalization of this Master thesis. In other units and Clusters of the Erasmus MC, the alignment of processes and ICT also seems to be a bottleneck. The occurrence of the lack of alignment at the Obstetric unit is not an individual case. As a result of that, the discussions and solutions about this topic can be generalized to other units and other Clusters. The setting and situation can differ of course, but the same ICT department is involved. Therefore the big figure will be more or less the same.

The hierarchy structure should be the same in all Clusters. This does not mean that the decision structure of all units and Clusters is the same. The involvement of different actors on different management layers could be quite different, depending on the situation. During the interviews with people from the ICT department, the decision structure came to attention. Some units have the same problems on the area of the decision structure. Therefore the discussions and solutions can be generalized to these units.

The historical growth of ICT systems differs per unit and Cluster. The same situation as on the Obstetric unit could be the case, but that is uncertain. The historical growth of ICT systems is dependant of a lot of factors. Solutions to reduce the amount of systems can therefore not easily be generalized to other units and Clusters. The future, on the other hand, will demand more integration of systems within the whole hospital.

The fact that MI is unknown within Cluster 12, makes it reasonable to assume that it in fact is also unknown in the other Clusters of the Erasmus MC. When talking about efficiency, MI can have a great attribution. Familiarization of MI must therefore be an agenda point of the ICT department.

6.3.2 Further research RvN

The goal of the RvN project is to gain efficiency throughout the whole Erasmus MC. To achieve this goal a lot of different efficiency researches were done. From the results of these efficiency researches agreements for a better efficiency are set up in management contracts. At that moment the task of RvN stops. A year after the management contracts, the Cluster looks whether the efficiency agreements are met. It is unclear what is done if efficiency isn't gained. At that point it is useful to find out why the agreements on efficiency aren't met. What could be the case is that the environment of the unit or Cluster has changed. Extra research at that point in time can be very useful. This research should be aimed at the achievements that were stated in the management contract. The goal for efficiency can then be adjusted to the current situation. Monitoring and scrutinizing the results stated in the management contract should result in more gain in efficiency. From the perspective improvement of efficiency, these scrutinizes should be done on a continual basis.

6.3.3 Further research general bottlenecks

The general bottlenecks, discussed in this Master thesis, lend themselves for further research. Especially the topic of integration of systems is interesting for further research. The relevance of integrating systems becomes more of a “hot” topic nowadays. A question for further research could be what the major causes for the diversity of systems are. This research could be done on more levels, such as national, regional and local. A follow up question is to look what the impact of the diversity of different systems is on the different levels. With the effects of impact the quality of care should be scrutinized. Is the offered quality to the patient at stake as a result of the quantity of different systems? What improvement of quality can be gained through integrating systems within health care organizations?

Another interesting topic, which is related to integrating systems, is standardization. A general rule is that 80% of the activities can be standardized. But what activities can be standardized in an automated system? It is useful to look at making a model of standardization for an automated system that can be used in healthcare. Such a model must be applicable on all different specialties. Activities that can't be standardized due to their specific characteristics can be filled in according to the necessities of the specialty.

6.3.4 Further research techniques of information architecture

In this Master thesis a model for the information architecture was presented. On the basis of this architecture a solution for the main bottlenecks were discussed. The architecture doesn't go deep into the technical side of the architecture. Interesting would be to look closer at the technical elaboration of this architecture. What are techniques that could be useful to make the architecture? Do the techniques cope with the expectations of the users? Are there any problems that occur after the chosen technique?

6.4 Conclusive

The process of doing research in general, is an iterative process. Research is about making a comparison of the practice with the theory. Eventually a new “theory” is the end result.

The researched practice on the other hand changes continuously, changing the basics of the variables of the research. From that point of view new research is needed to compare the theory with the practice. This is an iterative process. The same can be said for this Master thesis. The models and solutions of this model are liable of the changes that occur in the practice, the Obstetric unit in the Erasmus MC. When the research is finished, the situation of the researched object already has changed. Therefore research is never finished, only continued.

Appendix 1: Project “Ruimte voor Nieuw”

The research for this thesis was done from within the Research Team (RT). The RT was part of a hospital wide project called “Ruimte voor Nieuw”(RvN). Ruimte voor Nieuw is Dutch for creating space for new initiatives. Space is needed for academic research in the hospital. Due to changing budgetary lines, budgets for research got tighter.

The goal of the RvN project is to gain 10% efficiency hospital wide. The focus of efficiency is on direct and indirect patient care. For the project to be a success, a lot of research within the Erasmus MC is needed. The research itself does not take place on an aggregated level, but more on a decentralized level, namely the Clusters. There are 17 clusters and 8 directive boards within the Erasmus MC. They are further indicated as clusters. Several clusters are excluded from the project because they are not in any way involved with patient care.

4% average indirect for unit
6% average direct for unit
90% of the present budget
(Keep the good)

The 10 % efficiency, which is measured in monetary terms of the current budget of the cluster, is divided in two parts namely 4 and 6%. The 4% part flows into the Erasmus MC who spends it on e.g. the implementation of the Electronic Patient Record. The 4% part is invested in organization wide “infrastructure”. The other 6% is available for the cluster itself. They can spend it directly within their own cluster. They now have space for new things. Examples on what kind of things the “extra” money can be spent are more investments in education, because of smaller available scholarships, or cluster specific investments in ICT. Aspects of efficiency are about a better quality/cost ratio. This means e.g. better patient care, better patient logistics, stronger ICT, quicker walkthrough times and more research time. It is a “Multi criteria optimization problem”, which means that empiric decisions

about directing more or less about subject have to be made.

Efficiency isn’t always achieved easily. The improvement potential of efficiency has to be retrieved by doing research. The Research Team (RT) is responsible for this research. The efficiency research (DMO, from the Dutch Doelmatigheids Onderzoek) exists from the following segments:

- Patient satisfaction research (PTO, from the Dutch “Patient tevredenheidsonderzoek”);
- Client satisfaction Research (CTO, from the Dutch “Client Tevredenheidsonderzoek”);
- Employee satisfaction research (MTO, from the Dutch “Medewerker Tevredenheidsonderzoek”);
- Business Information, called Management Information in healthcare;
- Process analysis; and
- Time spending research (TBO, from the Dutch “Tijdsbestedingsonderzoek”)

These segments can also be referred to as the different viewpoints of the research.

The DMO determines the potential for improvement of the cluster. Efficiency can be measured on more levels. Better quality of care or a better patient satisfaction are also part of efficiency and part of the RvN project. Eventually these factors are converted into monetary assets. Better quality of care can also be expressed in money and therefore efficiency. The project isn't about cutting the budget of units.

Before these researches take place a preliminary research is needed. Before DMO was done a general process analysis took place. The purpose of this process analysis was to pinpoint sticking points and put them to use in further research. This DMO is discussed next, followed by explanation of the TBO and the set up of the process analysis.

Appendix 2: TBO

The TBO measures the time that is spent on the different tasks an employee has. It does not measure if activities or workflows run faulty or if employees do their work properly. The TBO measures the quantity of time spent on certain tasks on specific times. In short “are the tasks that are done within the cluster, the tasks that are supposed to be done”. In the end the available capacity has to be harmonized with the results to gain improvements in efficiency. For the period of a week, all the employees of cluster 12 have to keep track of the activities that they participate. During the measuring week all employees had a PDA (Personal Digital Assistant) for the input of their activities. The input took place every ten minutes. In the past ten minute period there are time slots of 2 minutes. That way activities can be measured on a detailed level. The advantage of these 2 minute time slots, is that disruptions that occur in the daily work can be registered accurately and are not easily neglected or forgotten. These disruptions are of great importance to measure inefficiency within the processes of the cluster. They also show whether workflows are affected by them. When these disruptions are known precautions can be taken to enlarge efficiency. Besides registering an activity, they also had to register an object. That object was about the location they did their activity, such as the operating room or patient room numbers. Object could also be for whom they were doing their activity. This could be for urology, gynaecology, the IVF-lab. Afterwards a figure can be made about whether which types of patients or specialties take the most time.

An important aspect of the TBO is to measure the time spent on patients. This time can be concluded from the activities used in the TBO. Measurement takes place on three main categories of patient time. These categories are: direct patient time, indirect patient time and condition shaping patient time. Direct patient time is the time actually spent with the patient, e.g. washing the patient or giving the patient his medication. The indirect patient time is that amount of time that is invested in activities that supports patient care without the actual contact with the patient. E.g. preparing medication for patients. The last category is the condition shaping patient time. This time is spent on supporting activities that are focused on setting the right conditions for the patient so that patient care goes more smoothly. Examples of conditional shaping patient time are filling up administrative papers or transporting patient beds. Efficiency is gained when the direct patient time increases and the indirect patient time is arranged in an optimal way. This means that no more time than necessary is spent in indirect patient activities. Saved time should be reassigned to direct patient time. Possibilities for optimizing indirect patient time is e.g. getting rid of hidden double administrative input of patient data. More examples of the practice of Cluster 12 are discussed in the paragraph on the Problem analysis of Obstetrics. The condition shaping patient time must be reduced as much as possible. An example, which occurred in another cluster, will illustrate this. In this example the transportations of patient beds was done by two experienced nurses. The first question that was asked is why two people are needed to transport one bed. The answer was that the bed was extremely hard to handle by one person during transportation. To resolve that problem the bed got a small electro motor. The next question asked was why such a highly educated nurse was used to transport the bed. It appeared there wasn't a good reason for that. As a solution the highly educated nurse was substituted for a less high educated person, whom is much cheaper.

Appendix 3: Example TBO result

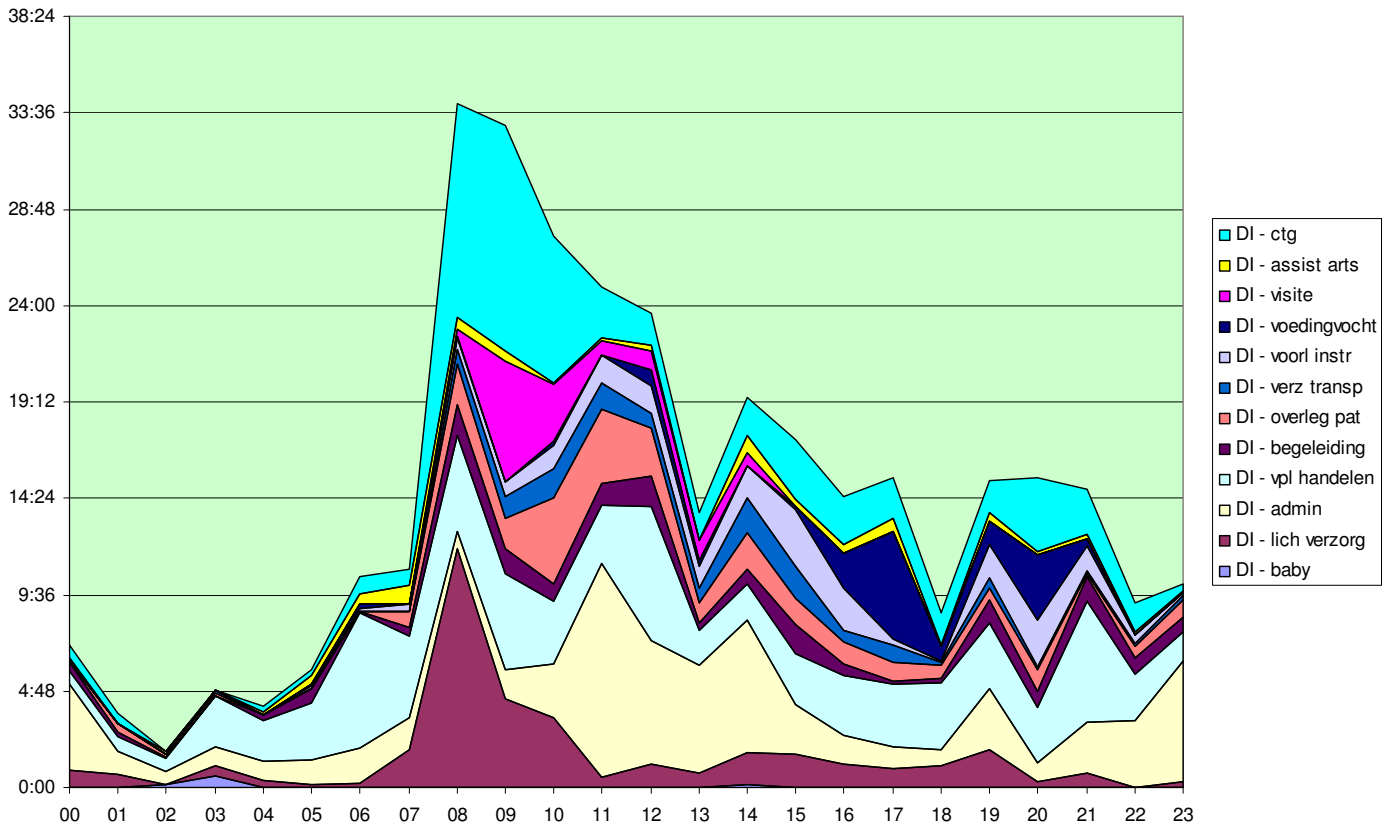

The x-axis represents the hours of the day. The y-axis is the cumulative time spent on an activity. For example, between 7.30 and 10.00 o'clock there is a peak in the activity physical care, “lichamelijke verzorging” in Dutch. The y-axis represents the cumulative hours of that day. From this graph temporary conclusions and further questions must be drawn. These results should also be compared with the results of other DMO researches.

Appendix 4: Process Analysis Obstetric unit

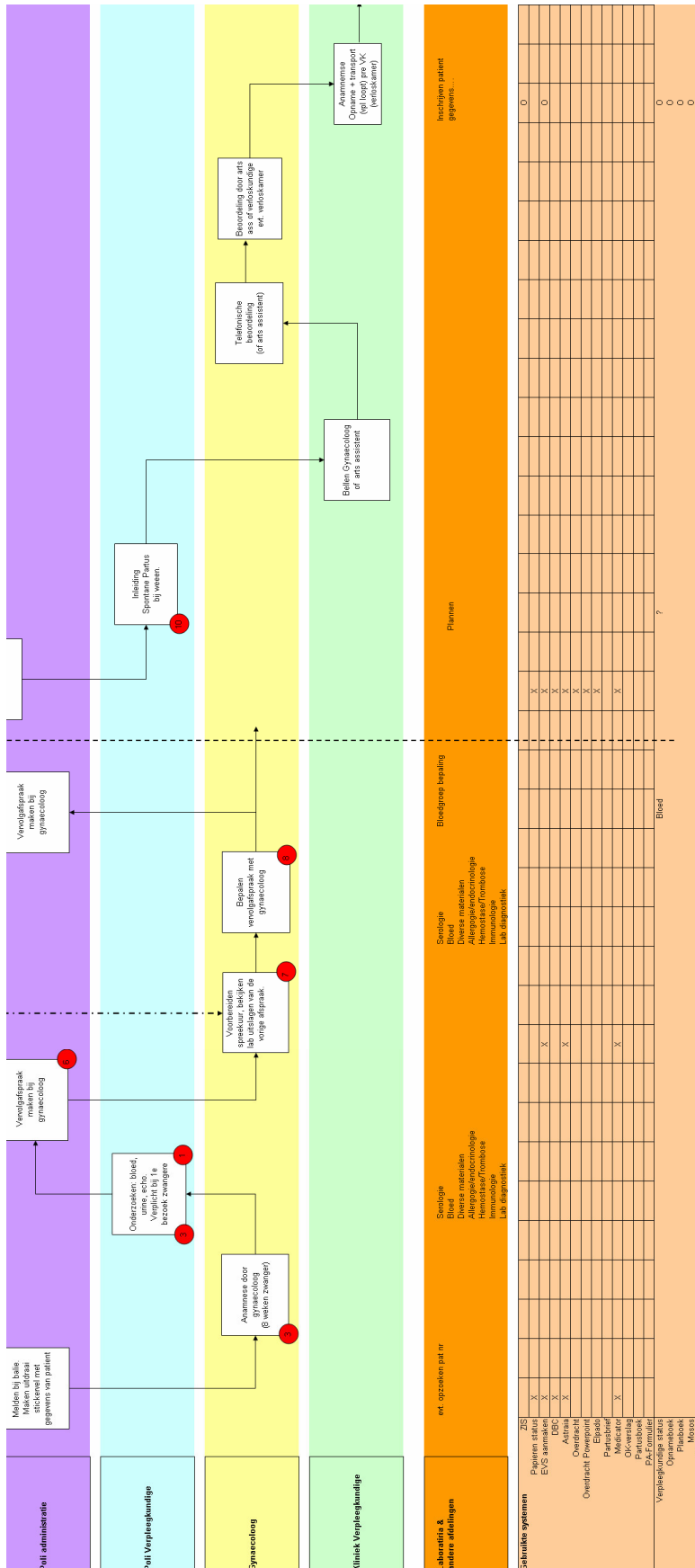

Appendix 5: Double administration Gynaecologist

Informatie-element:	Vastgelegd in:											
	Papieren status	EVS aanmaak	DBC	Astraia	Overdracht	Overdracht powerpoint	Partusbrief	Medicator	OK-verslag	Partusboek	PA-formulier	Whiteboard
Opname/ontslag	20	15		10	5	5		5			3	3
Geboorte							15	5	5	3		
controle	5	1	1									
afspraken	5	1	1									
medicatie	2	1						2				
anamnese	10	1	1									
rapportage	5	1	1									
Amenorroe/graviditeit/bloed	2	1		1								
Geboortegegevens	5	10	2							5		
Activiteitenlijst	3						10					
Verwijzer												
bijzonderheden												
notities												
Totaal	57	31	6	11	5	5	25	12	5	8	3	3

Appendix 7: Questions Interviews

1. What is the reason that the processes on the unit get little attention?
2. In which way can responsibilities for processes be created? Who has to be responsible for the processes?

3. Why aren't all representatives of the different actors involved in consultations about ICT projects?
4. In what way can more involvement of actors be achieved? Are changes in the current situation needed?

5. What is the reason that there are so many standalone systems?
6. What is the risk on medical faults? Is it clear where the most up to date data can be retrieved?
7. How can more uniformity of systems be achieved?
8. Is it possible to get to a more efficient and effective administration? How can this be achieved?

9. What is the reason that Management Information is hardly used?

ICT

10. What was the reason to choose for standalone applications?
11. What is the reason that uniformity of applications isn't realized before?
12. What is the feasibility of the information architecture, within the political, multi actor and financial environment of the Erasmus MC.

Abbreviations

AS	: Automated System
BPR	: Business Process Redesign
CTG	: Cardio Toco Graphy
CTO	: Cliënt Tevredenheidsonderzoek
DBMS	: Database Management System
DI	: Directie Informatie
EOR	: Electronic Obstetric Record
EOS	: Electronic Obstetric System
FTE	: Full Time Equivalent
FTE	: Full Time Equivalent
HAD	: Heterogeneous, Autonomous and Distributed
ICT	: Information Communication Technology
IS	: Information System
MI	: Management Information
MTO	: Medewerkert Tevredenheidsonderzoek
OM	: Order Management
PTO	: Patiënt Tevredenheidsonderzoek
QoS	: Quality of Service
RT	: Research Team
RvN	: Ruimte voor Nieuw
TBO	: Tijdsbestedings onderzoek
WfM	: Workflow Management
WfMS	: Workflow Management System
WMO	: Wet Maatschappelijk Ondernemen

Literature

Aalst, W. van der., K. van Hee. 1998. *Workflow Management. Modellen, methoden en systemen*. Schoonhoven: Academic Service Centra.

Aalst, W.M.P. van der & K.M. van Hee. 1997. *Workflow Management: Modellen, methoden en systemen*. Schoonhoven: Academic Service Informatica.

Anyanwu K., A. Sheth, J. Cardoso, J. Miller, K. Kochut 2003. *Healthcare Enterprise Process Development and Integration*. Journal of Research and Practice in Information Technology, Vol. 35, No. 2. May 2003.

Babbie, E. R. 2007. *The practice of social research. 11th edition*. Belmont, California: Thompson/Wadsworth.

Bal R., A. de Bont. 2005 *Taakherschikking en ICT in de Zorg*. In: Kennis in Netwerken: Jaarboek ICT en samenleving 2005. J. de Haan & C. van 't Hof 2006. Amsterdam: Uitgeverij Boom. 2005 (113-126).

Berg, M. J. Aarts, J. van der Lei 2003. *ICT in Health Care: Sociotechnical approaches*. Methods Inf Med 2003; 42: 297–301

Berg, M. 2002. *The search for synergy: Interrelating medical work and patiënt care information systems*. In: Methods of Information in Medicine.

Berg, M., J. Aarts, J. van der Lei. 2003. *ICT in Healthcare: Sociotechnical approaches*. In: Methods of Information in Medicine. 2003; 43, 297-301.

Bocionek, S., S. Brandt, J. Cseh, B. Haskell, D. Rucker, D. Thomas. 2001. *Built for success: The new clinical and financial IT solutions from Health Service*. In: Electro Media. Volume 69. p.p. 76-81.

Capgemini 2002. *BPR oftewel herontwerp van zorgprocessen: Een aanpak voor het realiseren van ingrijpende verbeteringen*. Symphora Groep, januari 2002.

Cardoso, J. 2002. *Workflow Quality of Service and Semantic Workflow Composition*. Department of Computer Science, University of Georgia, Athens, GA.

Cardoso, J., R.P. Bostrom, A. Sheth. 2004 *Workflow management systems vs. ERP systems: Differences, Commonalities, and Applications*. Information Technology and Management 5, 319–338, 2004. Kluwer Academic Publishers

Georgakolopoulos, D., M. Hornick 1995. *An overview of Workflow Management: From process modelling to workflow automation infrastructure*. Distributed and Parallel Databases, vol. 3, (119-153) 1995

Grefen, P.W.P.J. 2001. *Workflow Management: Geautomatiseerde ondersteuning voor integrale procesbesturing*. Alphen aan den Rijn: Samsom.

Kang, M.H., J.N. Froscher, A.P. Sheth, K.J. Kochut. 1999. *A Multilevel Secure Workflow Management System*. in *Proceedings of the 11th Conference on Advanced Information Systems Engineering*. 1999. Heidelberg, Germany, Springer. pp. 271-285.

Klischewski R. & I. Wetzel, 2001. *Serviceflow Management for Health Provider Networks*. Hamburg: Jahrestagung (pp. 313-319)

Klischewski R. & I. Wetzel, 2002a. *Serviceflow Beyond Workflow? Concepts and Architectures for Supporting Inter-Organizational Service Processes*.

Lin, F., S. Chou, S. Pan, Y. Chen. 2000. *Mining Time Dependency Patterns in Clinical Pathways*. Proceedings of the 33rd Hawaii International Conference on System Sciences - 2000

Pearson, S. D., D. Goulart-Fisher, T.H. Lee. 1995. *Critical Pathways as a strategy for improving care: Problems and Potential*. *Annals of Internal Medicine*. Volume 123 Issue 12; (p.p. 941-948)

Reingoud, A. 2006. *EMC Order Management Adviesrapport*. Version 1.1, July 2006. Erasmus MC Rotterdam

Siemens 2002. *Case Study: Siemens Health Services*. In: BPM 2003. Delphi Group, Boston.

Smagghe D., M. Segers, P.J. Spy-Anderson, N. Benamou, N. Eddabbeh. 2005. *Model of Good Practice Tools for Risk Reduction and Clinical Governance*. In: *The Journal on Information Technology in Healthcare* 2005 (3) 114: 117-124.

Strauss, A., S. Fagerhaugh, B. Suczek, C. Wiener. 1997. *Social Organization of Medical Work*. New Brunswick and London: Transaction Publishers.

Zuiderent, T., R. Bal, M. Berg. 2004. *Working differently: reorganizing intramural oncology*. *Daniel den Hoed Cancer News*, April 2004, 11-12.