

**2013**  
OYSTER  
Annual Report  
Engineering the Specs



# Colofon

## Coördination & text

TU Delft | Reactor Instituut Delft

## Design cover

Verdult - Kennis in Beeld, [www.kennisinbeeld.nl](http://www.kennisinbeeld.nl)

## Text editing

DBAR [www.DBAR.nl](http://www.DBAR.nl)

## Graphic lay out

LIN! Grafisch Ontwerp

## Production date

May 2014

## Funding

On January 20, 2012, the Dutch Council of Ministers decided to provide a financial contribution to the Reactor Institute Delft to implement the OYSTER program. This funding is provided via the Netherlands Organisation for Scientific Research (NWO project number: 195.069.000).

## TU Delft

### Reactor Instituut Delft

P.O. Box 5042 - 2600 GA Delft

Mekelweg 15 - 2629 JB Delft

T +31 015 27 86744

F +31 015 27 86422

I [www.rid.tudelft.nl](http://www.rid.tudelft.nl)

# The Second Year of OYSTER

## Foreword

The Reactor Institute Delft (RID) of Delft University of Technology (TU Delft) is a knowledge centre on nuclear issues, and it operates the reactor, its irradiation facilities and laboratories and its neutron- and positron instruments. In conjunction with the scientific Department of Radiation Science and Technology (RST) of the Faculty of Applied Sciences, RID accommodates resident and visiting scientists and other users from a variety of (scientific) disciplines, educates students, professionals and scientists, and serves as an independent source of information for society on radiation- and nuclear-related issues.

The OYSTER programme (OYSTER is "Optimized Yield - for Science, Technology and Education - of Radiation"), co-funded by the Dutch government, the TU Delft and a number of commercial parties, is to expand the potential of the research reactor by improvements and expansions of the RID infrastructure (reactor, instruments, facilities) to better address current and future educational, scientific and societal questions. Through OYSTER, RID also contributes in-kind to the ESS (European Spallation Source in Lund, Sweden), by means of the development of neutron instruments.

2013, the second year of OYSTER, has been dedicated to setting the requirements and conditions for the amendments to be made to the reactor (including the Cold Neutron Source). Furthermore, the first new neutron diffraction instrument to be commissioned (PEARL) is being built and has been taken into its position inside the reactor hall. Obviously, we are looking forward to have PEARL commissioned towards the end of this year!

RID started the European tendering for the reactor associated parts of OYSTER. At the same time the institute has been in continuous and fruitful dialogue with the Dutch Ministry of Economic Affairs on the implications of the implementation of the Dutch Safety Requirements that have to be in effect within the necessary licensing for the "after-OYSTER" operation of the RID reactor. The current annual report ("Engineering the Specs") will bring you up-to-date to all these and more OYSTER related issues of interest.

Needless to say that this second OYSTER year has once more been a team effort: full, challenging but awarding. It makes us look forward with confidence in our ambition to take on the OYSTER-boosted future positioning of RID.

Prof. dr. Bert Wolterbeek  
Director of the Reactor Institute Delft  
Head of the Department on Radiation Science and Technology  
May 2014

# Contents

<b>Foreword</b>	3
<b>Contents</b>	4
<b>Introduction</b>	5
<b>OYSTER in short</b>	6
<b>Reactor &amp; Utilities (Work Packages 1 and 2)</b>	8
<b>Instruments &amp; Facilities (Work Package 3)</b>	11
<b>Interview</b> Lambert van Eijck	13
<b>Interview</b> Bert Wolterbeek	21
<b>Financial overview</b>	22
<b>External review</b>	23
<b>Planning</b>	24
<b>Updated planning</b>	24 / 25
<b>Communication</b>	26

# Introduction

**On January 20, 2012, the Reactor Institute Delft (RID) of Delft University of Technology (TU Delft) was awarded 38 million EUR by the Dutch government for the OYSTER project (“Optimized Yield - for Science, Technology and Education - of Radiation”).**

The OYSTER project has been in development since 2005. It has been designed to expand the capabilities of the research reactor at the RID for the sake of the broader Dutch and international research communities. OYSTER will thus provide new scientific and innovative output and collaborations that in turn will secure the long-term future of the reactor. In 2012, the ambitious 10-year project was awarded 38 million EUR by the Dutch government, with TU Delft and industrial partners contributing 74 million EUR and 5 million EUR, respectively. It comprises the following items:

- OYSTER - Instruments and Facilities: design, development, construction and installation of facilities and instruments. The suite of instruments and facilities will be incrementally realized over the time span 2012-2020;
- OYSTER - Reshaping the Reactor: implementation of a cold neutron source (27 K) and optimisation of the reactor core. The cold neutron source and the new core will be operational in 2018;
- OYSTER - Exploiting the New Possibilities: stimulating groundbreaking scientific innovations, executing programs in collaboration with industrial and scientific partners.

**“OYSTER will thus provide new scientific and innovative output and collaborations that in turn will secure the long-term future of the reactor”**

An overview of developments that took place in the time span 2005-2012 can be found in the first annual report. This second annual report on OYSTER provides an overview of the developments that took place in 2013. It also looks forward, presenting the latest update of the planning.

PEARL testdetector assembly



## OYSTER in short

### OYSTER aims:

- To further develop RID/RST as a coordinating centre for the application of neutron, positron and radionuclide science and techniques, radiation detection and reactor technology, thereby supporting and uniting the Dutch scientific community;
- To create a home base for neutron scattering and mobilize the scientific community to secure Dutch collaboration with major international neutron sources;
- To establish RID/RST as a knowledge centre and training institute in Europe, and thus a coordinating partner in European research networks;
- To stimulate ground-breaking innovations in the field of neutron, positron and radiochemistry science;
- To sustain RID/RST leading role in the use and knowledge of world-class instruments such as continuous positron beams, the development of new routes for radioisotope production and the ISO 17025 accredited laboratory for Instrumental Neutron Activation Analysis;

### OYSTER technically comprises:

- The installation of a Cold Neutron Source (CNS), which will cool neutrons from room temperature to -246 °C and will thus increase the flux of low-energy neutrons by more than an order of magnitude. This will improve the sensitivity of already existing top-class instruments, such as SESANS or the neutron reflectometer ROG;
- The reshaping of the reactor core, thereby using the highest currently approved and proved density of uranium fuel, maximizing the neutron- and gamma-ray flux (since gamma-ray flux determines positron source brightness);
- The design and construction of new research instruments such as PEARL, FISH and PALS;
- The (re)design and construction of (new) irradiation facilities which permit the (development of) production of radionuclides with unprecedented purity, and increase the sensitivity and opportunities of research with isotopically enriched stable isotopes.
- The design and installation of a miniature hot-cell/decanning facility for submerged access of irradiated samples from the irradiation facilities. The hot cell serves mainly as a decanning facility of canisters containing samples, irradiated in the frame of the research programme on innovative production methods of (medical) radionuclides, and for subsampling of these samples to study radiation damage effects.

### Through OYSTER, TU Delft is better equipped to participate in large national and international collaborations:

- The development of the European Spallation Source (ESS, [www.EuropeanSpallationSource.se](http://www.EuropeanSpallationSource.se)) in Lund, Sweden, which is a collaborative facility for materials research using neutron scattering techniques. The Dutch contribution to the pre-construction phase of the ESS is financed through OYSTER. For this purpose two postdocs have been appointed, who work on the development of novel instrumental concepts for the ESS and in close collaboration with the ESS.
- Holland Particle Therapy Center (HollandPTC, [www.HollandPTC.nl](http://www.HollandPTC.nl)) for an innovative radiation treatment of cancer, using protons instead of X-rays, is a collaboration of TU Delft, the Leiden University Medical Centre (LUMC) and the Erasmus University Medical Centre Rotterdam (Erasmus MC) and will be located next to the RID/RST buildings. An intensive R&D program between the three partners has been set up to further improve the treatment.
- It also strengthens the role of the TU Delft in supplying innovative ideas towards the envisioned PALLAS reactor, one of the world's leading production sites for medical isotopes.
- Finally, OYSTER also strengthens the role of TU Delft's RID as IAEA Collaborating Centre by demonstrating the innovative opportunities in utilization of a medium-sized university research reactor.

### Technically, the realization of the OYSTER project is divided in three work packages, to be executed in parallel in order to get as many as possible of the new scientific instruments and facilities operational at the close-out of the project:

- Work package 1 "Reactor Modifications" consisting of a modification of the core in order to increase the neutron and gamma ray flux, optimization of the core design in order to realize the best conditions for the irradiation facilities, the design of a miniature hot cell, and the installation of the near-core part of the cold neutron source.
- Work package 2 "Utilities" consisting of the installation of support systems outside the reactor building.
- Work package 3 "Instruments and irradiation facilities" consisting of the installation or upgrade of a range of neutron and positron instruments and irradiation facilities.



# neutron and positron instruments

## Reactor & Utilities (Work Packages 1 and 2)

WP1, "**Reactor Modifications**", deals with a modification of the core in order to increase the neutron and gamma ray flux, and the installation of the near-core part of the cold neutron source and the design of the miniature hot cell. Optimization of the core design in order to realize the best conditions for the irradiation facilities is also part of this work package. The location of the hot cell has been re-considered in October 2013; preference has now been given to a positioning on top of the reactor pool (2nd platform) rather than on the reactor floor, which would require a reactor wall penetration. WP2, "**Utilities**", consists of the installation of all support systems outside the reactor building.

The definition phase of these closely connected work packages is almost complete. On March 1, 2013, the user requirements for the work packages served as basis for a preliminary "Request For Proposal" (RFP) document. For WP1, the first invitations for tendering were sent out in December 2012 (pre-qualification round) and the selection of the three bidders took place in 2013, as described below.

### Potential supplier pre-qualification (WP1)

A tendering process has been started in order to find a supplier for the realization of the technical part of the OYSTER WP1 and WP2 packages. Early 2013 the pre-qualification of potential suppliers was completed, in which a proven and up-to-date track record in relevant projects was one of the decisive

factors. Three suppliers were selected and invited to participate in the tendering process for receiving an order award for the execution of the OYSTER WP1 and WP2 packages. In consultation with International Tender Services BV (ITS, an external party specialized in European tendering procedures), a Request For Proposal (RFP) package was prepared and distributed to the various participants with the aim to make the final proposals available in September 2013.

As a consequence of the introduction of new legislation for nuclear reactor safety in the Netherlands (Dutch Safety Requirements or DSR, see below) in June 2013, the original RFP requirements and tendering schedule had to be adjusted. In consultation with the three potential suppliers the tendering schedule was extended with 6 months, which implies that the potential suppliers will need to tender their proposal documents before April 14, 2014 instead of September 2013. In order to prevent further delay in the tendering process, the December 2013 revision of the DSR requirements was used as Dutch Regulation input for the supplier.

It is foreseen that after receipt of the proposal documents in April 2014, evaluation of the tender packages will take approximately one month, which implies that the final decision for the contractor who will be invited to execute the OYSTER project will be known at the end of May 2014. After closing out of the objection period, it is expected that a formal contract agreement for the execution of the OYSTER project will be signed in June 2014.

Core including the Cold Neutron Source

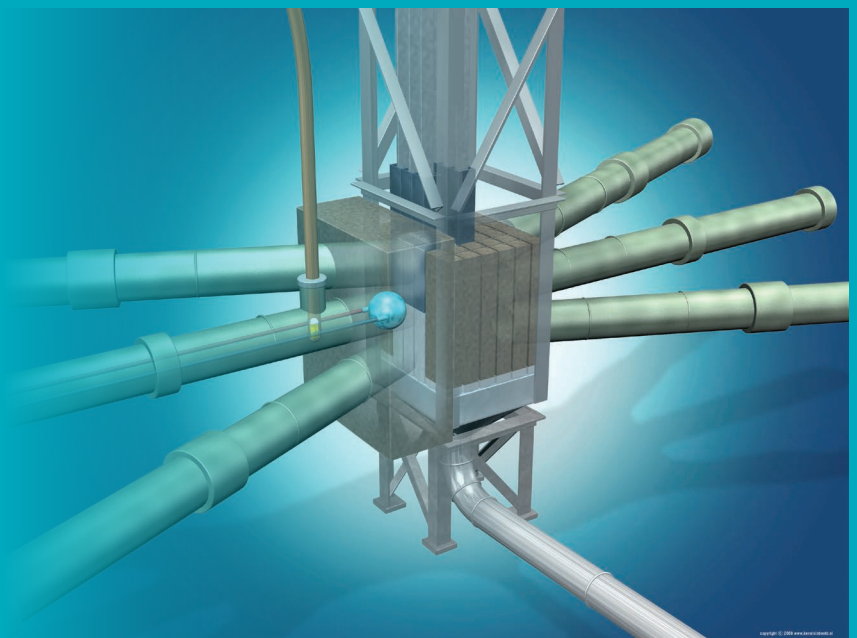



### External Expert Team

As part of the tendering process, many technical discussions will need to take place between RID and the potential suppliers. For the areas in which RID does not have sufficient in house expertise, an "External Expert Team" has been established. This team consists of external specialists who assist RID with the handling of the various technical issues raised by the suppliers. The timeframe where the involvement of these specialists related to the tendering process becomes important, is Q2 2014 (indicative). After the final supplier selection, further involvement of the Expert Team will be required to support the engineering and the construction phase (from Q2 2014 until 2017). In 2013, the following disciplines to be represented in the External Expert Team were identified:

- **Welding procedures**
- **Planning & cost control**
- **Materials**
- **Codes & standards**
- **CNS process technology**
- **Neutronics**

Potential candidates were invited and in January 2014 the External Expert Team became operational. It consists of:

Besides the involvement of the expert team, NRG was hired in for the preparation of the Safety Analysis Report and environmental study. In a joint effort between RID, the supplier and the Regulator, the DSR will be further worked out to a final legislation status.

Further, an external consultant (BonPhysics) specialized in Physics and Technical research was requested to advice RID in the field of CNS Utilities technology

<ul style="list-style-type: none"> <li>• <b>Toni Scheuer</b></li> </ul>	Nuclear Technology Consultant for TUV Rheinland Group. Specialized in licencing issues, QA/QC and material- and component qualification. In-service inspections, maintenance control of systems and components.	Welding procedures, Materials, Codes & standards
<ul style="list-style-type: none"> <li>• <b>Stephan Welzel</b></li> </ul>	Chief coordinator reactor upgrade Helmholtz-Zentrum Berlin für Materialien und Energie Zentralabteilung. Specialized in CNS process technology and operational aspects.	CNS process technology
<ul style="list-style-type: none"> <li>• <b>Stuart Ansell</b></li> </ul>	Scientist with ISIS STFC (UK). Specialized in Cold Neutrons equipment design for Research Reactors. Leading specialist within ISIS for optimization processes neutronics.	Neutronics

## Licensing

### Milieu-effectrapportage (MER)

One of the conditions for obtaining a new operating permit for the RID reactor is to describe the impact of the OYSTER modification project on the environment, through a so-called Environmental Impact Assessment (milieu-effectrapportage, MER).

As the first step towards this MER, a preliminary notification was published on May 15, 2013. On June 5 an independent MER advisor of the Ministry of Economic Affairs ('MER Committee') visited the RID to gather information about the OYSTER project. On June 13, 2013 a public event was organized to present the plans of OYSTER and to present the related intention to realize a MER to the general public. After a period of 6 weeks during which people could provide their views on the OYSTER plans, the MER advisor finalized an advisory report based on which the Ministry of Economic Affairs issued a detailed set of MER guidelines ('Notitie Reikwijdte en Detailniveau'). Because the contents of the MER also deals with detailed technical issues concerning the reactor, the execution of the study depends on the input of the contractor who will be selected for the execution of the OYSTER project. Since the contract is expected to be awarded in June 2014, the preparations of the MER will start in the second half of 2014.

### Dutch Safety Requirements (DSR)

The OYSTER project necessitates a modification of the existing licenses for the RID reactor. From the start of 2013 onwards the required licensing procedures and the pertaining review schedules for the OYSTER project approach were discussed with the regulating body, the Ministry of Economic Affairs. In June 2013, new and more stringent Dutch Safety Requirements (DSR) for new nuclear reactors were presented in a workshop and the Dutch nuclear community was invited to participate in the discussion with the Dutch regulator for advice and comments with regards to the further development of these new requirements.

As presented during the workshop in June 2013 a draft version of the DSR legislation was expected mid 2014. In December 2013 the Ministry of Economic Affairs reported that a draft version of the DSR legislation would be ready for internet consultation mid 2014 and that the implementation would follow at the end of 2014. Meanwhile, the formal submission of the new RID licensing has been in continuous preparation, in cooperation with the Ministry of Economic Affairs. As the full extend of the eventual DSR is not clear yet, the suppliers asked for more time to prepare their tender bids, to allow them to analyse the current state of the DSR regulations.

The Ministry of Economic Affairs contributed largely in helping the suppliers to understand important DSR issues.

## Issues currently being addressed

The following list is an overview of on-going steps for WP1 and WP2:

- Completing the user requirements for WP1 "Reactor Modifications". Besides necessary changes to the existing equipment, reactor-ageing issues are being investigated. A large update of the as-built reactor drawings is being executed. The design specification of the hot (decanning) cell has been established.
- Completing the user requirements for WP2 "Utilities". The Cold Neutron Source utilities imported from Germany are being scrutinized to decide which parts will be re-used and which have to be replaced. The most probable optimum location has also been defined for the utilities to be installed outside of the reactor containment.
- A definitive design of the new carbon-carbon composite irradiation end for CAFIA will be made, including the above water connection part. A proposal for funding by Technology Foundation STW of an advance lead-shielded facility (SIPF) will be submitted. Target cooling approaches are studied and where possible, also tested.
- Finding external support for the licensing procedure. For the Environmental Impact Assessment (MER), the Nuclear Research and consultancy Group (NRG) is providing support.
- Completion of the project schedule (engineering and detailed/construction phase).

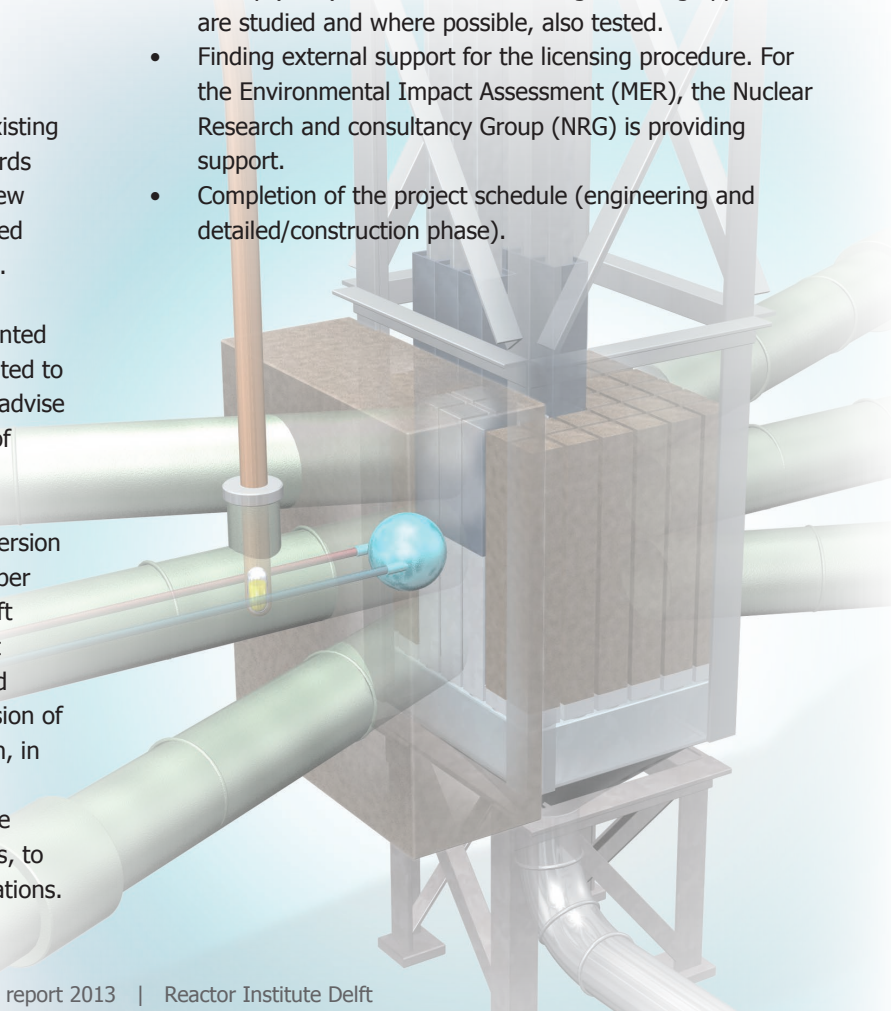

# Instruments & Facilities (Work Package 3)

Work package 3 consists of all neutron and positron instruments and irradiation facilities that will be installed or upgraded. As most instruments and irradiation facilities will be realized in-house, an RFP for this work package is not necessary. The planning for instruments and facilities follows a preset schedule, but is subjected to changes due to details in timing of instruments under construction, and the awarding of additional funding. At the time of printing of the 2013 annual review, timelines for instruments and facilities are being renewed, updated and made to match the newly emerged conditions: updated timeline information will become available on a short notice. The in-core and near-core irradiation equipment will also remain uncertain till the dialog between RID and the Ministry of Economic Affairs / the suppliers is finalized.

## A. Instruments

WP3 involves the following instruments:

- SANS – a new small angle diffractometer with a dedicated cold beam line
- PEARL – a new neutron powder diffractometer
- ROG – upgrade and relocation of the time-of-flight neutron reflectometer to a cold beam line
- SESANS – upgrade of spin-echo labelled SANS, a unique Delft instrument
- FISH – a new multi-purpose neutron imaging facility
- NDP – neutron depth profiling spectrometer
- POSH – intense positron beam
- PALS – positron annihilation lifetime spectroscopy, using positrons from POSH
- 2D-ACAR – upgrade of thin-film 2-dimensional angular correlation of annihilation radiation spectrometer, using positrons by POSH
- Mossbauer spectroscopy – a new in beam Mossbauer facility

Of this suite of instruments, SANS and PEARL have been (partially) designed and installed in 2013. The start of the other instrument projects awaits the required budget allocation.

## SANS

Particles with sizes from 1 up to a 100 nanometers scatter neutrons under small angles. The small-angle neutron scattering instrument (SANS) allows researchers to investigate structures in that size range. Typically, proteins, micelles, polymers, porous media and precipitates are investigated using this technique.

During 2013 and the first half of 2014 the separate components of the SANS instrument (acquired from the Helmholtz-Zentrum Geesthacht, Germany) were mechanically positioned in the experimental hall, aligned and fixed in their final position. The vacuum system was tested and the electronic motor control for the movement of the components was adapted.

Next steps in 2014 are the electronic/mechanical testing of the velocity selector, radiation safety tests and testing of the neutron detection system. When these steps are completed, the instrument will be calibrated using the thermal neutrons of the current reactor source. In the period before installation of the cold neutron source the instrument provides the opportunity to study strongly scattering samples. Furthermore, it will enable neutron imaging studies by the so called "baby FISH" (not to confuse with FISH).

*View of the SANS instrument under construction.*



## PEARL

The shielding and beam tubes have been successfully installed and aligned during the planned pause in reactor operation during the summer of 2013. Since the installation, the team has worked on the alignment and design of the monochromator and on the scintillator detector. The detector design was done in collaboration with the detector experts of ISIS, the pulsed neutron and muon source at the Rutherford Appleton Laboratory in Oxfordshire (UK). The prototype detector, built in Delft, has been validated for reactor-based operation in 2013. In the first half of 2014 the beam will be extracted towards the sample position and the first preliminary experiments will be performed with the prototype detector. The planned detector itself is currently in the construction phase. Clearance for operation of the beam shutter is expected for 2nd Q 2014.

## SESANS

Spin-echo small-angle neutron scattering (SESANS) measures structures in the range from 50 nanometer to 20 micrometer by using the Larmor precession of polarized neutrons in specially shaped magnetic fields. In 2013 the technique was applied to food materials, model mini-emulsions, aggregates of fine powders organized in a multiscale hierarchical structure, colloids with tunable interaction and porous materials such as graphite. Several experiments were done to develop a new method to perform SESANS. The precession devices can also be used to create a very fine spatial modulation of the intensity at a high-resolution position-sensitive neutron detector (see Figure 4.2). Any small-angle scattering of a sample will reduce the amplitude of the modulation. The advantage of this method is that all the spin manipulation occurs before the sample. Another feature is that this technique can be combined as an add-on to a polarized SANS instrument.

*Use of SESANS: the left figure shows the horizontal intensity modulation at a high-resolution neutron detector. The right figure shows the vertically integrated intensity of the detector. The modulation period is 0.1 mm, which is extremely fine.*

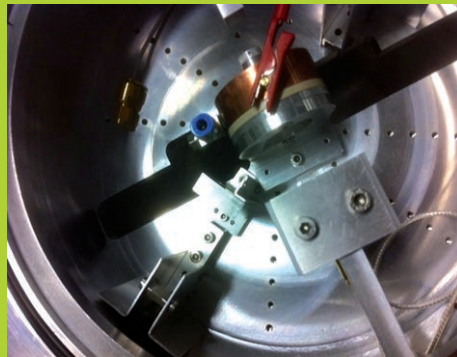
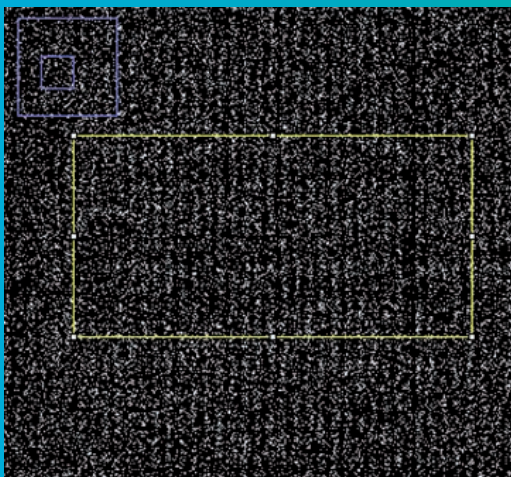

*In-Situ NDP on a Li-ion battery. The white arrow indicates the direction of the neutron beam.*

## NDP

Some elements produce charged particles with high energies when irradiated with neutrons. These charged particles can be observed from outside the irradiated material, revealing their concentration and depth at the same time. This information can be used to determine the depth profile of the particular element. Neutron Depth Profiling (NDP) can be used for example, to directly observe the motion of lithium ions inside Li-ion batteries. A special cell to make this possible has been designed giving unique and direct insight in kinetic and ageing processes that otherwise are very difficult to monitor under realistic conditions.

Currently, novel detector geometries are considered to eliminate the requirement of working in a vacuum and to image the depth profile over the plane of the sample aiming at both higher time and spatial resolution. This is expected to make NDP a key technique to understand the macroscopic distribution of the charge carrying Li-ions which is necessary to develop high performance Li-ion batteries as required for electric vehicles.

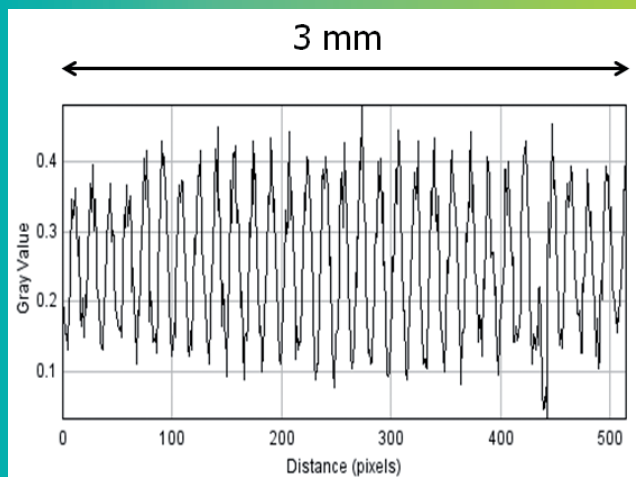

## INTERVIEW WITH LAMBERT VAN EIJCK

# Researcher at the Radiation Science & Technology department, Reactor Institute Delft

2013 was the year in which we accomplished a massive part of the PEARL neutron powder diffractometer. For me, the realisation of what has been in our minds and computer models for several years was really rewarding. The year already started off with a sprint in engineering design work and as the team grew bigger, communication and planning became more important. The production of the hundred tonnes of shielding had to be finished before we could proceed with the major operation of the installation in the reactor dome. In the limited timeslot that was available to us for this operation, all the pieces of the optics, alignment and shielding fell together nicely.



Lambert van Eijck

When we started with PEARL in 2010, a small team of scientists worked on the comparison of two common diffractometer concepts. From this comparison it turned out that the classical diffractometer concept would perform better at our reactor, due to some recent technological developments and insights. The choice of building such a diffractometer however also implied that we had to put a major effort in the shielding design. As the design of the instrument and the shielding became more detailed, the team grew and got more multidisciplinary. A large part of my efforts during that time was to communicate the design considerations that we made, back in 2010/2011, to this multidisciplinary team that had to put the ideas into drawings, tolerances and production.

The choice was made in 2013 to first focus on the parts towards the reactor core, the massive parts of the shielding and the "optics" within that shielding. These are the parts that needed to be installed in "one go" and the only available timeslot for that was the summer stop of the reactor

in 2013. In a relatively short time the concepts were turned into well-produced pieces of a 3D puzzle, each of which was absolutely essential to start the installation program. As more of those pieces came in, the work of the design office started overlapping with that of the workshop(s) and my role changed to showing off these achievements to my scientist colleagues and the management.

The installation of the shielding and optics in the summer of 2013 started off with truck loads of concrete and during two months a team involving several people across the institute successfully performed this complex operation and solved the problem that appeared on the way. This is something we're all proud of. What we've learnt from this project is that we can achieve things like this through team work and by putting in a lot of effort together. There will be more of such big installations during the realization of the OYSTER program, like the reactor upgrade or the installation of the cold source. The PEARL project was a good test case, through which we learned how to run such complex projects, where lots of partners

are involved and where it is essential to deliver both in time and in budget. We hadn't done anything that big for quite some years now.

PEARL will unravel the crystal structure of materials on nanoscale, for example energy materials that are used for batteries or solar cells; and helps scientists to improve them. The instrument uses the neutron radiation from the reactor, from which the monochromator reflects neutrons to the sample. The scattered neutrons from the sample are measured by the detector, which is located around the sample. The resulting diffraction pattern is the "fingerprint" of its crystal structure.

The monochromator and detector will be produced, aligned and installed in 2014, and form the core of the diffractometer. In that sense, 2014 will be the most interesting part of the installation project, from a scientific point of view. PEARL will be the only neutron powder diffractometer in the Netherlands. We expect it to become a competitive instrument, which implies that once it is finished, end 2014, it will enable several important experiments to be performed in Delft and not at other neutron sources, e.g. in France or the United Kingdom.

***"We expect it to become a competitive instrument"***

## POSH-PALS

The positron annihilation lifetime spectroscopy (PALS) technique is based on the measurement of the time elapsed between injection ("start") and subsequent annihilation ("stop") of a positron in a solid. The positrons are delivered by the intense positron beam POSH. A typical positron lifetime spectrum may consist of several lifetime components, which range from 100 pico-seconds to several nano-seconds. Therefore efficient and high time-resolution detection of the start and stop trigger signals is crucial. To this aim scientists working in the research at the RID, with expertise in the fields of positron physics, generation of intense positron beams, ultrafast annihilation photon detection and the development of charged particle detectors have been brought together to focus and strengthen the research on these challenging topics.

Thus far, several exploring bachelor student-projects have been successfully carried out. The next steps involve the acquisition of additional research funding through national and international funding schemes. A first success has been obtained by the awarding of the second-phase ADEM project entitled "Thin film positron annihilation lifetime spectrometer POSH-PALS for advanced characterization defects and nanostructure of thin film solar cell layers" by S.W.H. Eijt, H. Schut and M. Zeman.

## NEUTRON IN-BEAM MÖSSBAUER SPECTROSCOPY Investigating Industrial Materials/ Catalysts under Authentic Working Conditions

Mössbauer spectroscopy has proven to be very valuable for the in-situ/operando studies of heterogeneous catalysts. The high penetrating power of  $\gamma$ -rays makes Mössbauer spectroscopy a very versatile technique to study catalysts in their working state, providing promising routes to develop understanding of the catalytic sites better and opening ways to synthesize novel or improved catalysts. It is a powerful technique to characterize nanosize particles and to elucidate not only the phases of certain compounds (fingerprinting), but also to provide detailed information about valence state and particle-size distributions.

The Mössbauer effect was observed on 82 isotopes of 44 elements, but only a few of them are used in practice. The  $^{57}\text{Fe}$  and  $^{57}\text{Co}$  Mössbauer spectroscopy is applied in 80% of the cases,  $^{119}\text{Sn}$  accounts for 10% of the studies, while all the others share the remaining 10%.

In this project, the number of usable Mössbauer nuclei will be increased by producing them in-beam. Neutron capture

prompt-gamma nuclei for in-beam excitation like  $^{157}\text{Gd}$ ,  $^{155}\text{Gd}$ ,  $^{167}\text{Er}$ ,  $^{161}\text{Dy}$ ,  $^{177}\text{Hf}$ ,  $^{163}\text{Dy}$ ,  $^{179}\text{Hf}$ ,  $^{171}\text{Yb}$ ,  $^{154}\text{Gd}$ ,  $^{173}\text{Yb}$ ,  $^{160}\text{Dy}$ ,  $^{182}\text{W}$ ,  $^{56}\text{Fe}$ ,  $^{66}\text{Zn}$  and  $^{39}\text{K}$  will be produced. Continuously activated prompt-gamma Mössbauer nuclei like  $^{153}\text{Er}$ ,  $^{166}\text{Er}$ ,  $^{175}\text{Lu}$ ,  $^{186}\text{Os}$ ,  $^{191,192}\text{Ir}$ ,  $^{195}\text{Pt}$ ,  $^{197}\text{Au}$  can also be used in beam. Longer half-life nuclei ( $^{141}\text{Pr}$ ,  $^{127}\text{I}$ ,  $^{129}\text{I}$ ,  $^{181}\text{Ta}$ ,  $^{182}\text{W}$ ) can be activated and used for Mössbauer experiments during the reactor shutdown periods. Apart from catalysis (Pt, Au, W, I, Ir, K, Zn, W, Gd, Hf, Dy, Er, Yb), additional fields of application can include: high-temperature superconductors (Pr), magnetic layers (Gd, Er, Dy, Yb), biological systems ( $^{40}\text{K}$ ) and the study of the chemical behavior of the nuclear waste of  $^{129}\text{I}$ .

We have recently demonstrated the feasibility of using high-pressure in-situ cells for Mössbauer experiments at liquid helium temperature, following reaction treatments at temperatures up to 773 K and pressures up to 40 bar. After extensive discussions with representatives of Hositrاد Holland BV (The Netherlands) and ColdEdge Technologies (United States) a decision has been made to build a state-of-the-art facility for combined in-situ/operando catalytic reactions and low-temperature Mössbauer spectroscopy measurements. A ColdEdge closed cycle 4.2 K cryostat will be modified to accommodate a high-pressure in-situ cell for reaction treatments under real industrial conditions. The proposed combined in-situ cell will be used in the neutron in-beam facility for Mössbauer spectroscopy experiments on different isotopes.

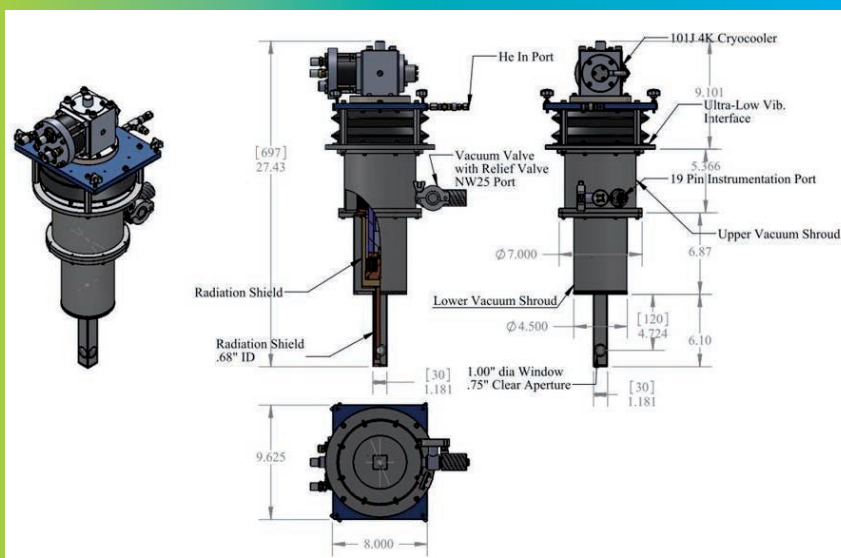

*ColdEdge closed cycle 4.2 K Mössbauer cryostat.*

## B. Irradiation facilities

The irradiation facilities of the RID reactor allow materials to be irradiated with neutrons or other types of radiation in a well-controlled environment. They are used for research on and with radionuclides and for analytical purposes such as Neutron Activation Analysis (NAA). For each specific purpose there is a dedicated facility. Optimal irradiation conditions can be selected (e.g. samples shielded from  $\gamma$ -rays, cooled, irradiated by thermal or epithermal neutrons, short- or long irradiations), mostly depending on characteristics such as the radionuclide of interest and the nuclear reactions required.

Below we comment on the two branches of research in general and the specific (planned) irradiation facilities, focusing on recent developments.

### Radionuclide research

Nuclear research reactors are indispensable for the realizing radionuclides such as  $^{99}\text{Mo}/^{99\text{m}}\text{Tc}$  and increasingly also  $^{166}\text{Ho}$  and  $^{177}\text{Lu}$ , used by medical clinical- and research institutes for (radio-) diagnosis and therapy. Delft scientists developed a process for realizing highly specific  $^{99}\text{Mo}$  by recoil separation from neutron-activated  $^{98}\text{Mo}$ , and a new sorber material for

the  $^{99}\text{Mo}/^{99\text{m}}\text{Tc}$  generator. Research on radiation damage effects – either during irradiation or inside the generator – require irradiation facilities in which the irradiated material can be cooled and shielded against reactor gamma-rays (PRT-C and/or SIPF), and the hot cell.

Research on radiation damage effects is also needed for expansion of the use of  $^{166}\text{Ho}$  microspheres. The radionuclide  $^{166}\text{Ho}$ , packed in poly(L-lactic acid) (PLLA) microspheres) are classified as a medical device for the treatment of liver metastases. This treatment is currently explored in the University Medical Centre Utrecht. The holmium microspheres are at the moment neutron-activated for up to 6 hours in the HOR. An activity has to be produced of 12.5-24 GBq per 600 mg microspheres, right after neutron activation. A higher specific activity will further boost the use and effectiveness of these microspheres in the therapy. It was previously established that at the HOR facility a limited irradiation time (up to 7 hours) could be used before surface damage of the particles occurs, thus limiting the specific activity of  $^{166}\text{Ho}$ -microspheres. The damaged microspheres not only change their shape but they become leaky and therefore totally unusable. In other nuclear facilities (e.g. the High Flux Reactor) damage is even more profound (Figure below).

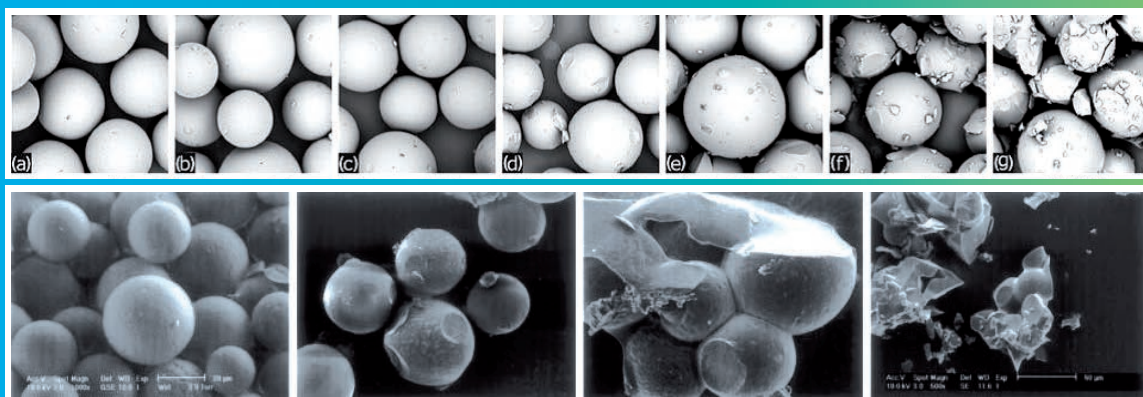

Scanning electron micrographs of Ho microspheres neutron-irradiated for 0, 2, 4, 6, 7, 8, or 10 h, revealing damages and disintegration after 7 h.

Substantial improvement in this specific activity is expected when the gamma-ray dose deposited on the  $^{166}\text{Ho}$ -PLLA-MS is reduced and if cooling of the targets during the irradiation can be provided. The shielded irradiation facility (SIPF) will serve this purpose. A proposal has been submitted to Technology Foundation STW to realize this facility for increasing the specific activity of  $^{166}\text{Ho}$  in PLLA microspheres.

## Neutron Activation Analysis (NAA)

Many chemical elements such as Cu, Zn and Fe are considered to play an essential role in metabolism. They are necessary in growth and maintenance processes and, as part of many enzymes and co-enzymes, play an important role in chemical reactions and metabolic processes. Information on element behavior can be obtained by using radioisotopes as a tracer, but there are severe restrictions in clinical application due to the associated radioactive dose. Isotopically enriched stable isotopes are therefore the alternative in screening, diagnostics and research. Our research program focuses on the role of (trace) elements in relation to the ageing population. This is currently applied in a research program together with Meander Medical Center in Amersfoort on the effectiveness of iron supplementation in elderly patients with iron disorders. To this end, the iron supplementation is enriched in the isotope  $^{58}\text{Fe}$ . As neutron activation of iron results in two radionuclides ( $^{59}\text{Fe}$  and  $^{54}\text{Mn}$ ), the measurement of the ratio of these radionuclides in body tissues indicates which fraction results from the supplementation. Dietary intake, whole blood, urine and feces are collected during a period of 3-5 days. The iron content of the dietary intake is measured using the BISNIS facility; the measurement of the iron content in large amounts of urine and (lyophilized) feces is currently done using the regular irradiation facilities of HOR but will be considerably eased once the new Pool-side intermediate Large Sample Facility (PLSF) becomes available. As such, it initiated the orientation phase for PLSF.

The research programme is to be expanded towards studies of the trace element physiology changes with ageing and

trace element deficiencies from patients treated for cancer and bariatric surgery. A higher neutron flux in PRT and CAFIA will increase the sensitivity in these studies for analysis of e.g. biopsies whereas BISNIS and PLSF will provide world unique research opportunities by analysis of large, inhomogeneous amounts of material. As such, the pre-design of a new pool-side irradiation end of CAFIA (providing a 5-10 times higher neutron flux) has been re-evaluated for further detailing.

## Pneumatically operated small-target irradiation facilities

*CAFIA-thermal/epithermal (Carbonfiber Autonomous Facility for Irradiation and Analysis)*

CAFIA is a dedicated system where irradiation facility and spectrometer are combined in a single instrument in which the activity of very short half-life radionuclides (i.e. half-lives down to 1 second) can be measured without unpacking the irradiation container. A pre-design of a new carbon-carbon composite irradiation end, housed in an aluminum encapsulation of dimensions (see Figure on the right), closely matching the HOR fuel element dimensions – thus fitting on the reactor grid – has been reevaluated for further detailing. A mechanism is currently under study for disconnecting the tubing system in case the reactor bridge has to be moved, including the new CAFIA irradiation end on the grid.

It has not been decided yet if one system will be developed with a movable Cd sleeve for epithermal activation (CAFIA-E), or if two individual but exchangeable systems (without and with permanent Cd sleeve) are preferred.

*Schematic presentation of CAFIA and first design of new carbon-carbon composite irradiation end.*

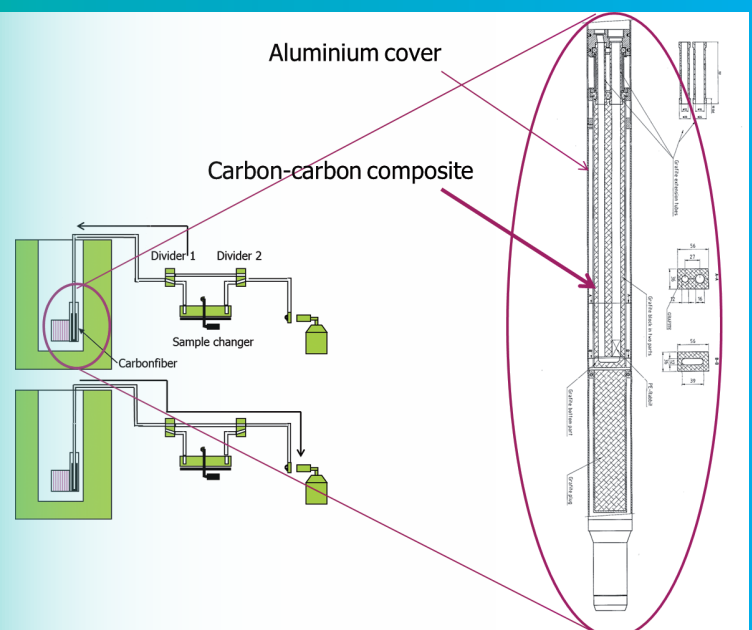



### PRT's (Pneumatic Rabbit Transfers)

- PRT-C
- The potential of Aerogel as an insulation material resulted in a pre-design of an irradiation container; it will be experimentally assessed as soon as it's available.
- PRT-T and PRT-E
- No developments in 2013 pending the decision on the new design of the HOR.



*Pneumatically operated small-target irradiation facilities. The photograph shows the PE rabbit loaded into the inlet of the pneumatically operated transport system (to and from the irradiation position).*

### Manually operated small-target irradiation facilities

#### CNIPF (Cold Neutron Isotope Production Facility)

It has been decided to abandon this irradiation facility as the design of the CNS does not allow the insertion of a vertical irradiation channel without perturbation of the associated n-beam characteristics.

#### ICIPF (In-Core Isotope Production Facility)

ICIPF is a new irradiation facility with submerged loading/unloading for transport of samples towards hot cell entrance. No developments pending the decision on the new design of the HOR.

#### LIF (Long Irradiation Facility)

LIF is a new irradiation facility at the highest possible neutron flux if existing 'small BEBE' can't be combined anymore after reactor core modification. No developments pending the decision on the new design of the HOR. Merging the design with the design of ICIPF has been considered.

#### SIPF (Shielded Irradiation Pneumatic Facility)

SIPF is a new irradiation facility for irradiations with lead filters of adjustable size and thickness. A research proposal for the design, implementation and testing of this facility has been prepared in 2013 and submitted in 2014 to Technology Foundation STW, as a collaboration of TU Delft and the University of Utrecht, supported by four industrial partners. The objective of this project is to design an irradiation facility for irradiation of organic materials and especially Ho-containing microspheres composed of PLLA-MS, achieving in this case specific activities of at least 25 GBq (per 108 mg Ho), without damaging the organic matrix. The facility will be thus designed that removable lead shields of various thicknesses can be applied for optimizing the neutron/gamma-ray intensity ratio. The facility will allow for loading and unloading the targets during reactor operation offering flexibility in irradiation time.

#### RIF (Resonance Irradiation Facility)

RIF is a facility with adjustable and removable neutron filters for optimized use of resonance neutrons in isotope production. This facility for irradiation with 'resonance' neutrons of a selectable energy will be unique in the world and can result in unprecedented improvements of the radionuclide purity and specific activity. Radionuclides can then be produced by activation in a neutron energy spectrum with the highest intensity in the region of specific resonance neutron energies and (if relevant) simultaneous reduction of the thermal neutron production of interfering radionuclides. A first orientation learns that elements like Sc, Fe and Si may serve as absorbers resulting in irradiation conditions with almost mono-energetic neutrons of epithermal energy.

**GIPF (Gamma Irradiation Production Facility)**

GIPF is a new facility for selective use of high-energy reactor gamma rays to enhance photon activation and suppress interfering neutron activation. A prototype has already been tested. No developments in 2013.

**Large-target irradiation facilities****BISNIS (Big Samples Neutron Irradiation System)**

BISNIS is an existing facility, which is to be modified as part of OYSTER. Over the past year, the enhancement of the thermal neutron flux by removal of the Cd-sheet has been studied again; new modeling results indicate a lower enhancement compared to the modeling done 15 years ago. The cause of the discrepancy is not clear yet.

**PLSF (Pool-side intermediate Large Sample Facility)**

PLSF allows sample masses of 10 – 100 g for research on the optimal target dimensions for industrial production. It is positioned in water reflector ex-core on the experimental grid at a thermal neutron flux  $10^{11} - 10^{12} \text{ cm}^{-2}\text{s}^{-1}$ . A flat plane irradiation container of limited thickness (1-2 cm) is considered to minimize neutron self-shielding and self-thermalization effects. The container will be positioned in the facility with its plane parallel to the reactor's outer plane.

*Location of the Cd-sheet in front of thermal column, indicated in a HOR scale model*

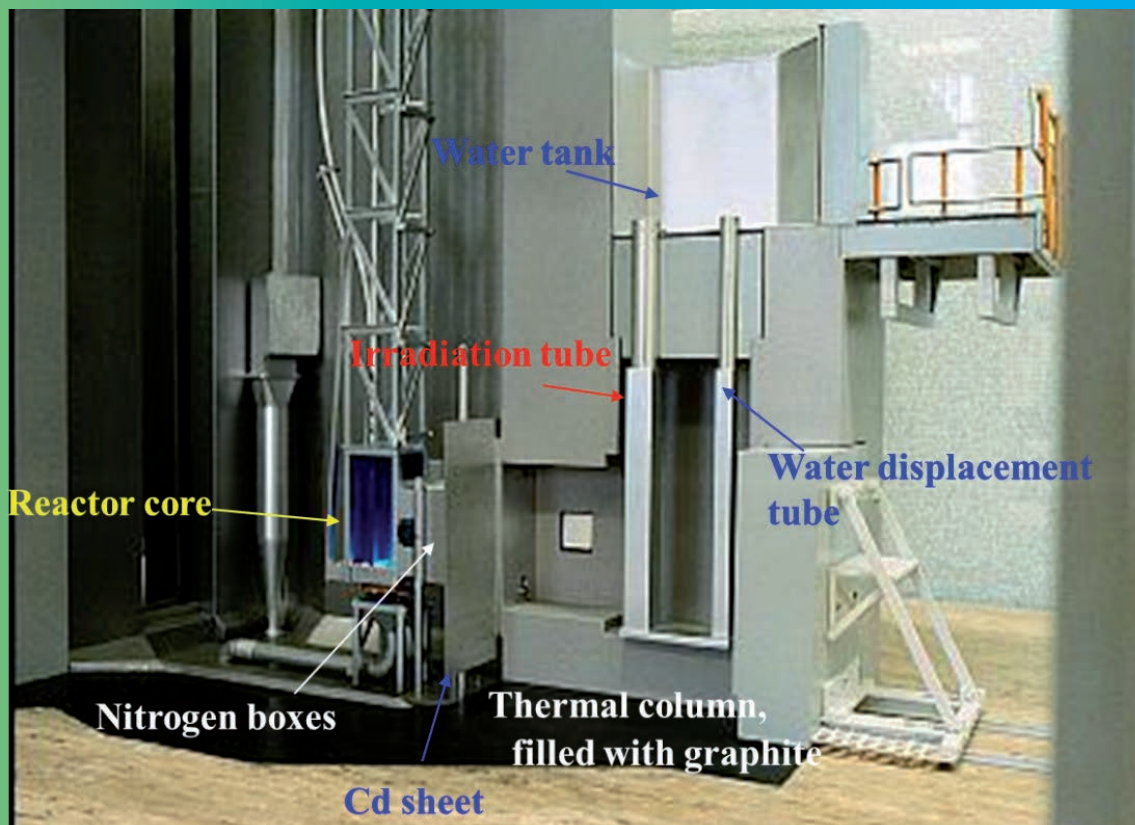

### Loop irradiation facilities

#### IPL (Isotope Production Loop)

IPL is a new irradiation facility in beam tube for on-line radionuclide production and on-line separation (outside biological shield) of radionuclides from liquid target compounds. No developments in 2013.

#### MSL (Molten Salt Loop)

No developments in 2013.

### Decanning Hot cell

#### UWC (Under Water Connection)

We have concluded that there is no need for UWC anymore, because of the selection of a different position of the hot cell during 2013, see below.

### The hot cell

In 2013 a new location for the hot cell has been selected, without the need for access from the reactor pool by

penetration through the biological shield. The (miniature) hot cell will now be placed on the HOR's second platform, on top of and slightly overreaching the large pool (see Figure on the right). Samples will be directly loaded into the hot cell from the large pool. This new positioning will require elevating the pool bridge by approximately 30-50 cm. The technical specifications of the cell have been further detailed as part of the RFP.

### Molybdenum-99 production facility

No developments in 2013.

### Issues currently being addressed

Completion of the user requirements for WP3. Algorithms are under development to enable optimization of the different instruments.

*Schematic positioning of miniature hot cell on the 2<sup>nd</sup> platform*

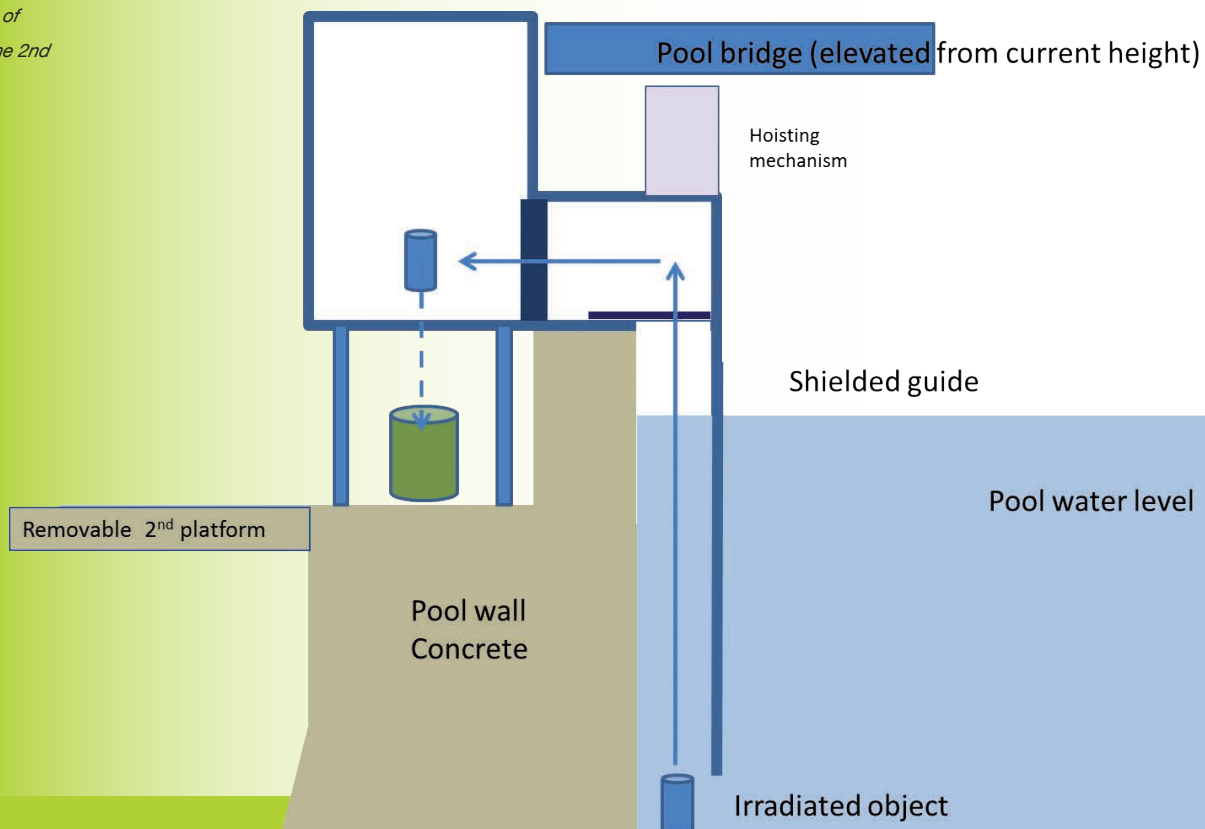

# CORE close up

## INTERVIEW WITH BERT WOLTERBEEK

# Director of the Reactor Institute Delft | Door: Eveline Thoenes

The OYSTER program is quite a large project, with many organisational challenges as well as technical ones. It's interesting, because we continually have to consult with lots of different people from a number of organisations: from ministries, funding bodies and the scientific community, to people who take part in the modifications to our reactor and companies that supply parts.



Bert Wolterbeek

In the past year, we have established all the quality requirements for the reactor modifications and set goals for the instruments and facilities that are to be built. This was sometimes quite difficult, as these demands were occasionally at odds with each other. But the nice thing is that eventually, thanks to joint effort, we managed to accomplish it nevertheless. That's an exciting process to be a part of. One of the challenges is to keep everything within the time and funding frame we originally had in mind.

The first tangible result we achieved in 2013 is that of the series of instruments we are developing, the first one, PEARL, is almost ready to be put into operation. It was fascinating to witness the way scientists, technicians, draftsmen and designers all worked together in one colossal project to create this complex, new instrument. It's a matter of teamwork and persevering in spite of setbacks. For them it's also quite special to work on something this big and with so many people from different backgrounds, all working towards a common objective.

We are also developing instruments for the new European Spallation Source (ESS) neutron facility in Sweden. There was a lot that needed to be discussed regarding technical requirements, funding and all kinds of other practical aspects with people from ESS and with the scientists who will eventually use the facility. But all that has gone exceedingly well. It's a very positive cooperation. One of the things we want to accomplish through OYSTER is that the Reactor Institute Delft becomes more valuable to the Dutch industrial and scientific community. We are therefore in close deliberation with them: they tell us what sensitivity and resolution they need for their measurements, at which atmospheric pressure and temperature they want to investigate their samples and so on. We will develop instruments that match those criteria and implement the necessary adaptations to the reactor itself, so that the neutrons

supplied to these instruments match the given requirements in intensity and quality.

The main thing we have learned so far is that for a project of this magnitude, it is essential that every single person

***"One of the challenges is to keep everything within the time and funding frame we originally had in mind"***

in the institute is thoroughly committed in order for it to be a success. This might seem self-evident, but in the academic environment that we're in, everybody has their own research goals that they want

to achieve as well. But I was very pleased to see that in the course of last year, everyone started becoming more involved and more enthusiastic.

My personal ambition for the coming year is to even further improve the team bond that is necessary for the OYSTER programme to be successful. It's going very well, but anything can always be improved.

# Financial overview

## Overall budget at the starting date

OYSTER as a whole amounts to 117 million EUR, covering the initial investments as well as the operational costs over a period of 10 years. TU Delft contributes 74.0 million EUR in kind, industrial partners 5.0 million EUR, for which the TU Delft stands surety. In 2012 the Dutch government awarded 38.0 million EUR for OYSTER. On January 20, 2013, the Executive Board of TU Delft confirmed January 1, 2013 as the formal start date of the project.

## Consequences of new safety legislation

Changes in the project due to new legislation for nuclear reactor safety (DSR), as described in Chapter 3 of this report have substantial impact on not just the planning but also the financial situation. The new and more stringent safety requirements will lead to higher investment costs. Furthermore, additional and prolonged external expertise will be needed. Final impact of the new DSR on the OYSTER scope will only become clear by the end of 2014. The original OYSTER project budget was defined in 2011. At that time the new legislation could not be foreseen so the cost impact of the new DSR requirements was not included in the projects budget. Therefore a Change Order Notification was issued requesting for additional budget in order to mitigate the extra costs.

## Expenditures and funds received in 2013

As a result of changed project planning, major investments as originally planned for 2013 have been postponed.

- A total of 1,7 million EUR was spent on the licensing process, the tender process and on the positioning of the OYSTER facility.
- For the construction of PEARL 1,5 million EUR has been invested, of which 0.7 million EUR was spent in 2013. The total TU Delft contribution amounts to 0,8 million EUR. To realize further instruments and irradiation facilities, plans have been formulated to attract external funding.
- TU Delft contributed 9,0 million EUR in kind to the OYSTER project.
- 0,1 million EUR was received as scheduled from COVRA, of the 0,3 million EUR awarded in 2012 to OYSTER.



**PEARL**  
alignment on  
Monochromator Center

# External review

In July 2013, NWO requested a committee of the external experts to review progress in the OYSTER project. The “NWO OYSTER Advisory Committee” consisted of the following people:

## Prof. K.N. Clausen

Dr. Clausen is Head of the Neutron and Muon Research Department and vice Director of the Paul Scherrer Institute (Switzerland). He is a member of the ESFRI Physical Science and Engineering working group and served until 2013 as Head of the technical advisory committee for the European Spallation Source project. He was previously head of the neutron scattering, magnetism and superconductivity research at Risø National Laboratory in Denmark and external Professor at the Niels Bohr Institute in Copenhagen. Dr Clausen coordinated and chaired the European roundtable for neutron scattering and Muon beam sources from 1997-2003.

## Dr. Dimitri N. Argyriou

Dr. Argyriou is Director for Science at the European Spallation Source. He received his Ph.D. from the University of Technology, Sydney (Australia) in 1994 and did postdoctoral research at Argonne National Laboratory. After taking staff appointments at the Argonne and Los Alamos National Laboratories he moved to Germany to lead a group in researching novel electronic and magnetic materials at the Helmholtz Centre Berlin.

## Prof.dr. J.F. Verzijlbergen

Prof. Verzijlbergen heads the Department of Nuclear Medicine at the Erasmus University Medical Centre Rotterdam (Erasmus MC). He is President of the European Association of Nuclear Medicine (EANM), Formerly Nuclear Physician at St. Antonius Hospital, Nieuwegein and Nuclear physician at the Rivierenland Hospital in Tiel (The Netherlands). Previously he was President of the Board of the Dutch Society of Nuclear Medicine (NVNG).

## Dr. Nico Kos

Dr. Kos is Senior Manager (International) Programme Innovation at the Chemical & Physical Sciences Division of the Netherlands Organisation For Scientific Research (NWO). He obtained his Ph.D. from Wageningen Agricultural University. After a short postdoc period he worked at the policy department in Wageningen and later of the Technical University Delft. Thereafter he held several positions within NWO. In his present job he is responsible for several national and international programs, mostly interdisciplinary.

## Outcome

The committee concluded it was “pleased with the execution of the project” and made various recommendations, of which the most important ones are summarized below:

Recommendations	Implementation
Locate additional funds.	Talks are ongoing with various parties (incl. the private sector) to obtain funds for the instrument innovations of OYSTER.
Determine a strategy for the Centre of Excellence, which will result from the OYSTER project, involving the research community.	The strategy is under development with the stakeholders in the Netherlands and abroad.
Attract additional expertise in fields where in-house expertise is lacking.	The External Expert Team (see page 9) was created to address this issue.
Appoint a “champion” for each new instrument.	Senior scientists to act as “champion” have been appointed. The scientists are currently preparing plans for both scientific projects and valorisation involving “their” instrument.
Work with NRG with respect to the irradiation facilities.	Talks with the NRG management are ongoing to realize and formalize this collaboration.

# Planning

The original project schedule of the OYSTER project was based on terms and conditions as defined during the first half of 2013. After notification of the new DSR legislation in June 2013, the original schedule was adjusted. Closing out of the OYSTER project is now foreseen for Q1 of 2018.

# Updated planning Construction Phase

## OYSTER Reactor Modifications Project

Activity ID	Activity name	Start	Finish
<b>Milestones</b>			
M001	TIC OVERALL ESTIMATE		31-mrt -15
M002	FABRICATION EQUIPMENT POWER INCREASE AND CNS INPILE PART		31-mrt -16
M003	CONSTRUCTION SECURITY CHECK		31-dec-14
M004	SHUT-DOWN REACTOR		1-jul-17
M005	START-UP REACTOR		31-dec-17
M006	CLOSE-OUT OYSTER PROJECT		31-mrt-18
<b>Activity</b>			
<b>RABZ GENERAL</b>			
	TIC OVERALL ESTIMATE	01-apr-14	31-mrt-15
	CONSTRUCTION SCHEDULE	01-apr-14	31-mrt-15
	SECURITY/DECOMMISSIONING PLAN	01-apr-14	31-dec-14
<b>RABX REACTOR MODIFICATIONS</b>			
	MER PREPARATION + REVIEW	01-jun-14	30-sep-15
	DSR DEFINITIO	01-jan-13	31-dec-14
	PREPARATION CONCEPT LICENCE	01-apr-14	31-dec-15
	SAFETY REPORT (VR) PREPARATION + REVIEW	01-apr-14	31-dec-15
	LICENCING PROCEDURE	01-jan-16	30-sep-16
	BUILDING PERMIT	01-jul-16	31-dec-16
	OBJECTION PROCEDURE	01-jan-17	30-jun-17
	DETAILED ENGINEERING POWER INCREASE, CNS INPILE PART AND DSR	01-apr-14	31-mrt-15
	FABRICATION EQUIPMENT POWER INCREASE AND CNS INPILE PART	01-apr-15	31-mrt-16
	SHUT-DOWN REACTOR AND DISMANTLING CORE	01-jul-17	
	DRAINING REACTOR BASSIN 1ST STAGE INCL. DISMANTLING HANGER ECT.		
	AS-BUILD CHECK CORE AND BASSIN CONFIGURATION		
	DRAINING REACTOR BASSIN 2ND STAGE FOR BEAM TUBES DRY		
	DISMANTLING MIRROR GUIDE SYSTEM BEAM TUBE R2		
	MODIFICATIONS BEAM TUBE R2 AND REACTOR CORE		
	MODIFICATIONS REACTOR BASSIN		
	INSTALLATION HOTCELL, ISOTOPE - AND LOOPSYSTEM FACILITIES		
	REFILL REACTOR BASSIN 1ST STAGE INCL. INSTALLATION NEW CONTROL RODS		
	AS-BUILD 0-MEASURING AND REFILL REACTOR BASSIN 2ND STAGE		31-dec-17
	START-UP / COMMISSIONING	01-jan-18	31-mrt-18
	DETAILED ENGINEERING HOTCELL FACILITIES	01-jan-15	30-jun-15
	DETAILED ENGINEERING E&I MODIFICATIONS PI AND CNS INPILE PART	01-jan-15	30-jun-15
	MODIFICATIONS E&I RELATED TO PI AND CNS INPILE PART	01-jul-15	31-mrt-16
<b>RABY CNS UTILITIES</b>			
	DETAILED ENGINEERING CNS UTILITIES AND CONTROL ROOM	01-jan-15	30-jun-15
	BUILDING PERMIT	01-jul-15	31-dec-15
	INSTALLATION NEW CNS UTILITIES AND CONTROL ROOM	01-jan-16	31-mrt-17
	DETAILED ENGINEERING CNS COOLING SYSTEM AND COMPRESSOR	01-jan-15	30-jun-15
	MODIFICATIONS CNS COOLING SYSTEM AND COMPRESSOR	01-jan-16	31-dec-16
	DETAILED ENGINEERING CNS E&I MODIFICATIONS	01-apr-15	30-sep-15
	INSTALLATION E&I EQUIPMENT RELATED TO CNS SYSTEM	01-jan-16	31-dec-16
	START-UP / COMMISSIONING	01-apr-17	30-jun-17



- Construction Phase (Preliminary)

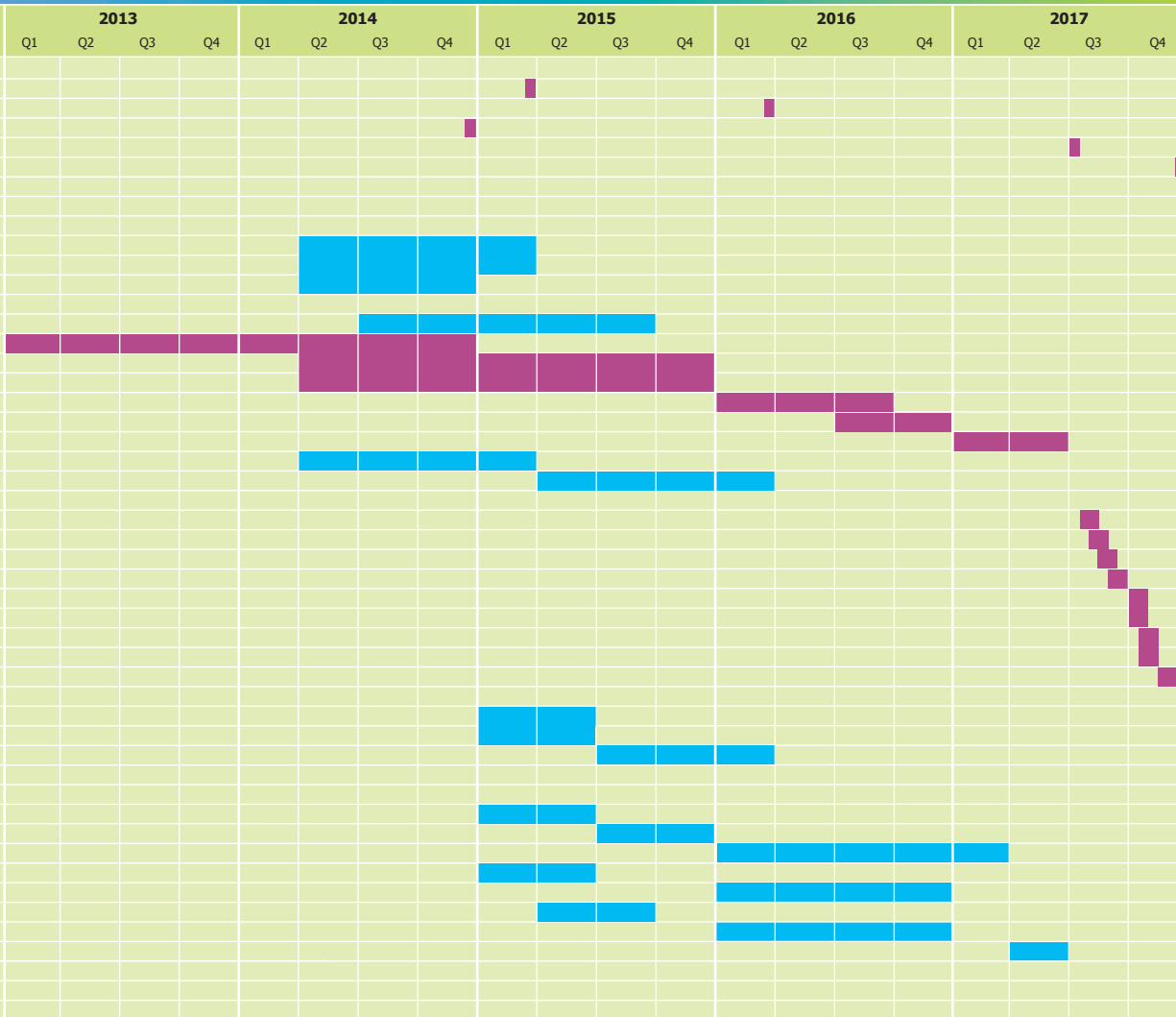

Date	Revision	Approved
14 March 2014	Rev. 10	
7 April 2014	Rev. 11	
8 April 2014	Rev. 12	



# PEARL

## Communication

The OYSTER programme will result in improved and expanded infrastructure around the reactor in order to better address current and future educational, scientific and societal questions. This is the key message that we want to share and instil across the relevant research communities and other stakeholders. We aim to inform researchers and scientists, whether from academia, SME's or large companies, as well as non-governmental organizations about the opportunities, instruments, facilities and know-how available at the Reactor Institute Delft. In order to achieve this goal, a communication strategy has been developed in 2013. This communication strategy defines the common goals and tasks and determines the actions required to inform and involve various stakeholders, among which the employees, the scientific community, governmental stakeholders, and the general public.

In 2013, the implementation of the communication strategy was started and resulted in, amongst others:

- Monthly project reports informing stakeholders about the progress of the OYSTER project.
- Bi-monthly plenary meetings for all employees.
- The first year report of the OYSTER project, chronicling the history and progress of OYSTER. This report has been distributed widely and can be accessed online.
- Publication of the first announcement of the MER.
- Together with the ministry of Economic Affairs, a public meeting within the context of the Environmental Impact Assessment (MER) has been organised in 2013 to provide an opportunity for the general public to gain insight into the OYSTER programme and the developments at the Reactor Institute Delft
- Articles about OYSTER in the Reactor Institute Delft's internal newsletter
- An OYSTER website (in Dutch) where the general public can find information about the project and the scope of OYSTER.
- A weblog by Prof. Bert Wolterbeek, director of the Reactor Institute Delft, to inform various stakeholders.
- An Open House event for various stakeholders and citizens of the Delft region.
- Technical tours for secondary schools (34 schools in 2013) in which students, under strict conditions, capture a video of their tour and share it on social media (average multiplication factor: 10).

<sup>1</sup> See <http://www.tnw.tudelft.nl/nl/samenwerken/faciliteiten/reactor-instituut-delft/oyster/>

<sup>2</sup> See <http://www.tnw.tudelft.nl/nl/samenwerken/faciliteiten/reactor-instituut-delft/nieuws/artikel/detail/berts-blog-over-neutronenonderzoek-in-Europa/>



