

2015

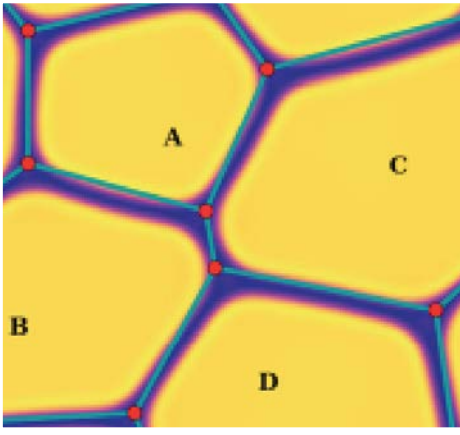

2016

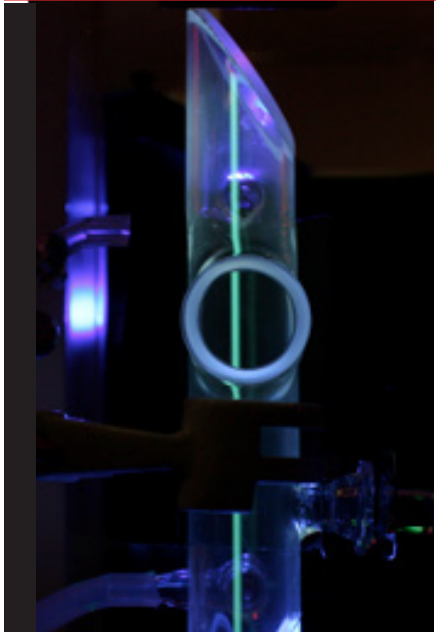
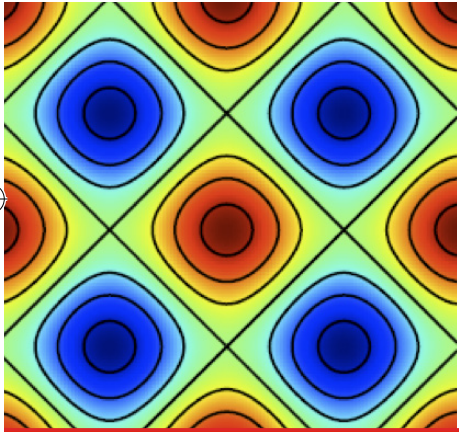
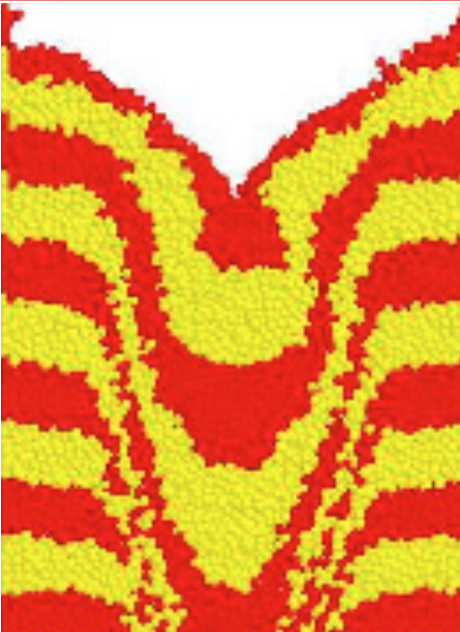

ANNUAL REPORT & RESEARCH PROGRAMME

J.M.Burgerscentrum 

Research School for Fluid Mechanics
TUD, TUE, UT, RUG, WUR, UU



ANNUAL REPORT & RESEARCH PROGRAMME 2015-2016

JM Burgerscentrum
Research School for Fluid Mechanics

TUD, TUE, UT, RUG, WUR, UU

© June 2016, JM Burgerscentrum

All rights reserved. No part of this publication may be reproduced in any form by print, photoprint, microfilm or any other means without written permission of the rightful claimant(s). This restriction concerns the entire publication or any part of it.

CORRESPONDENCE FOR REPRODUCTION

JM Burgerscentrum
Attn. Mrs. IJLM Hoekstein-Philips
Mekelweg 2
2628 CD Delft
The Netherlands
+31 (0)15 278 3216
jmburgerscentrum@tudelft.nl
www.jmburgerscentrum.nl

Burgers Program for Fluid Dynamics (University of Maryland, USA)
www.enme.umd.edu/burgers/

Contributions of the participating groups, Industrial Board and Contactgroups. Final editing : Prof.dr.ir. GJF van Heijst and Mrs. IJLM Hoekstein-Philips of the JM Burgerscentrum.

Design and lay-out : IJLM Hoekstein-Philips
Printed by : NIVO, Delft

PREFACE



Prof.dr.ir. CJ van Duijn
Chairman of the JMBC Board



Prof.dr.ir. GJF van Heijst
Scientific Director

This annual report of the J.M. Burgerscentrum provides an overview of the activities of our research school during the last year (2015). The core of the report consists of the description of the research projects, carried out by the JMBC groups. In each report the relevant information (title, theme, staff involved, project aim, achievements, publications, funding source, application, etc.) is given. As usual, a number of research highlights are presented. The Annual Report also provides general information about the research school, such as its goals, its organization, and its relation with industries and technological institutes.

The number of PhD projects carried out by the JMBC groups is still quite large (about 300). Although the sponsoring of such projects directly via the universities has become almost non-existing, the financing of projects via NWO (in particular FOM and STW) and via industries and technological institutes remains at a high level. Sponsoring of projects via the European Research Council is increasing. Finding funds for our PhD projects remains an important task for all JMBC groups.

The JMBC course programme for the academic year 2015 – 2016 contains the following courses: 'Particle-based modeling techniques', 'CFD 1', 'Combustion', 'Soft and granular matter', 'Computational multiphase flow', 'Experimental techniques', and 'Turbulence', while courses on 'PIV', 'CFD 2', 'Dispersed multiphase flows', and 'Capillarity-driven flows in microfluidics' are planned for the next year. These courses are organised in order to give the JMBC PhD students the opportunity to deepen their knowledge in various aspects of fluid dynamics, but also to widen their perspective and give them an overview of the wide field of fluid dynamics. It is therefore recommended for our PhD students to take the opportunity and to participate in these courses.

The activities of the JMBC continue to ensure that the Dutch fluid mechanics field is a lively and well-connected community, with numerous mutual appointments at collaborating groups and collaborative research projects in which multiple JMBC groups participate. The JMBC contact groups continue to be an important instrument for cohesion. These contact groups stimulate interaction and collaboration between researchers, developers, and users. This is done through organizing regular meetings aimed at getting to know each other's activities and learn about developments and applications. Another important instrument to maintain the coherence throughout the research school is the annual Burgersdag for all scientists involved in the JMBC and for many fluid-mechanics experts from industry, TNO and technological institutes. In January 2015 the Burgersdag attracted a large number of participants (approximately 250). An important item of the programme of this JMBC meeting was the farewell of Prof. Gijs Ooms as scientific director.

Once a while, we are approached by groups that are potentially interested in becoming a member of our research school. For admission of a new group, we follow a standard procedure. The group leader of the group that wishes to participate needs to submit a written motivation, a research plan and CVs of the staff members involved. Based on this application the scientific director asks a number of professors in the JMBC for advice. The application and the advice are then sent to the board of the JMBC, which takes the final decision.

Jointly with the research school Engineering Mechanics, the JMBC forms the Centre of Excellence 'Fluid and Solid Mechanics'. This centre also forms the basis of the 3TU Research Centre Fluid & Solid Mechanics (FSM), which receives financial support from the 3TU Federation. This support is generally used to enhance the profile and visibility of the 3TU Research Centre FSM, to promote collaboration with industrial partners, to expose the relevance of research in fluid and solid mechanics to society, to support young scientific talent, and to attract international top-quality visiting scientists. A number of calls for proposals have been issued in 2015, and most of the proposals received have been granted.

After many years of serving as chairman of the JMBC Board, the term of Prof. G Lodewijks ended in June 2015. The new chairman of the Board, Prof. CJ van Duijn, was appointed per 1 July 2015. A similar change took place in the Industrial Advisory Board: the chairmanship of this board was taken over from Dr R Duursma (Tata Steel) by Dr P Veenstra (Shell) per 1 January 2015. We say thank-you to the leaving chairmen, and we are looking forward to a fruitful and pleasant collaboration with the newly appointed chairmen.

Due to the enthusiasm and the combined knowledge, skills and facilities of the participating research groups, the JMBC remains to be a very stimulating, multidisciplinary environment for advanced research in fluid mechanics and for the education of talented graduate and postgraduate students. The board and the management team of the JMBC highly value the large effort of the staff of the JMBC in reaching the goals of the research school.

Prof. dr. ir. CJ van Duijn
Chairman of the JMBC-Board

Prof.dr.ir. GJF van Heijst
Scientific Director JMBC

CONTENTS





CONTENTS

ORGANISATION

13	Introduction
16	Participating universities and groups
18	Industrial Board
19	Contactgroup “Multiphase Flow”
19	Contactgroup “Computational Fluid Dynamics (CFD)”
19	Contactgroup “Combustion”
20	Contactgroup “Lattice-Boltzmann techniques”
21	Contactgroup “Turbulence”
21	Contactgroup “Experimental Techniques”
22	Contactgroup “Biological Fluid Mechanics”
23	Contactgroup “Microfluidics”
24	Burgers Program for Fluid Dynamics at the University of Maryland

HIGHLIGHTS

27	Magnetic artificial cilia generate microfluidic flow <i>Ye Wang, Ruth Cardinaels, Patrick Anderson, Jaap den Toonder (TU/e)</i>
31	The aerodynamics of flight maneuvers in fruit flies <i>Florian T. Muijres (WUR)</i>
35	Modelling barrier coast dynamics <i>Pieter C. Roos (UT), Henk M. Schuttelaars (TUD), Ronald L. Brouwer (Flanders Hydraulic Research)</i>
37	Micro-mechanics of wet solids in gas-solid contractors <i>GMW Kroesen (TU/e)</i>

RESEARCH

43	Introduction
43	Description of the research themes
45	Review of progress in research projects

TUD

47	Fluid Mechanics
71	Marine Technology
73	Dredging Engineering
79	Numerical Analysis
97	Mathematical Physics
103	Transport Phenomena
123	Product and Process Engineering
131	Nuclear Energy and Radiation Applications
137	Aerodynamics
153	Environmental Fluid Mechanics
177	Geoscience and Remote Sensing

TUE	
Mesososcopic Transport Phenomena	187
Vortex Dynamics and Turbulence	193
Transport in Permeable Media	217
Elementary Processes in Gas Discharges	223
Multiphase & Reactive Flows	233
Energy Technology & Fluid Dynamics	257
Microsystems	273
Cardiovascular Biomechanics	285
Centre for Analysis, Scientific Computing and Applications (CASA)	291
Applied Analysis	301
Multiphase Reactors Group	307
UT	
Computational Biophysics	369
Physics of Fluids	337
Physics of Complex Fluids	401
Soft matter, Fluidics and Interfaces	409
Applied Analysis & Mathematical Physics (AAMP)	415
Mathematics of Computational Science	417
Multiscale Modeling and Simulation	421
Engineering Fluid Dynamics	425
Thermal Engineering	445
Multiscale Mechanics	453
Water Engineering and Management	467
RUG	
Computational Mechanics and Numerical Mathematics	487
WUR	
Experimental Zoology Group	493
Agrotechnology and Food Sciences	497
UU	
Institute for Marine and Atmospheric Research Utrecht (IMAU)	499
Dynamical Oceanography at IMAU	501
WHO AND WHERE	
Participating groups and project leaders	505
JMBC Board of Directors	508
Management Team	508
Industrial Board	508
JM Burgerscentrum (The Netherlands)	508
Burgers Program for Fluid Dynamics (University of Maryland, USA)	509



ORGANISATION





ORGANISATION

The research programme of the JMBC has been ordered in research themes and focal points. The reason for this ordering is to present a combination of projects which have coherence, either in terms of physical models or in terms of mathematical methods.

THE MAIN THEMES ARE:

1. Complex dynamics of fluids
2. Complex structures of fluids
3. Mathematical and computational methods for fluid flow analysis

DESCRIPTION OF THE RESEARCH THEMES

1. Complex dynamics of fluids

Fluid flows in the environment or in industrial applications are almost always characterised by some form of complexity. Frequently it is this complexity that makes the flow an interesting topic of research. Below some examples are sketched of such flows and flow phenomena which form research topics carried out in the various JMBC groups. The first form of complex dynamics which comes to mind is turbulence, in contrast to a laminar flow. Here complexity appears in the form of strong non-linearity. Due to its chaotic behaviour turbulence can be considered as the archetype of a complex flow, and – being far from solved – turbulence will remain a strong focal point of research in the coming period. Turbulence research traditionally addresses the following questions:

- what are the physical processes and interactions governing turbulence?
- how can they be quantified and described mathematically?
- how to predict turbulence and turbulent flow for particular configurations?
- how to control and manipulate turbulence?

Future research in this field in particular will focus on laminar-to-turbulent and reverse transition, effects of thermal buoyancy, unsteadiness, compressibility and rotation, and on the interaction with chemical reactions. The role of turbulence in energy conversion processes and equipment is regarded as an intriguing field of applications.

Complexity may also appear in the form of a combined flow of various phases. When these phases are immiscible, phenomena such as free surface flows occur. These may appear in the form of various wave phenomena, for instance on an unobstructed water surface, but also in a confined geometry of a pipe.

Another type of such flow of immiscible phases is when one of the phases is distributed in the form of small particles, bubbles or droplets in the other continuous phase. Various combinations of phases may be selected and each has its own particular problems. This class of flows, generally denoted as ‘dispersed multi-phase flow’, forms a strong focal point of research within the JMBC. The combination of phases that are miscible leads to other interesting problems such as mixing, and – depending on the fluids that take part in the mixing – chemical reactions or combustion.

Finally, complexity of the flow can also appear through its boundary conditions. For instance the flow geometry can strongly influence the flow characteristics by means of straining, shearing and distortion. An example is the wake behind a body in a shearing or straining flow.

Furthermore, the exact formulation of boundary conditions can have a consequence for the type of flow characteristics that appear. An example is the free convection above a flat surface with a variable conductivity. Geometry constraints on the flow are also dominant when considering a flow in 2D versus 3D. An example is the quite different characteristics of 2D turbulence versus 3D turbulence.

The tools to carry out this research are primarily numerical and experimental. The numerical techniques used to compute flow phenomena are direct and large eddy numerical simulation, turbulence modelling and computational fluid dynamics. Also particle-based methods, such as the Lattice-Boltzmann technique, play an increasingly important role.

The experimental techniques used nowadays are mostly based on various forms of laser diagnostics (e.g. like PIV and PTV for flow measurements and CARS, LIF and Cavity Ring-Down Spectroscopy for temperatures and concentrations). Experiments, simulations and analytical theories in the field of fluid flow analysis complement each other – perhaps more than any other branch of physics. Future research will inevitably make use and take advantage of combined techniques and their complementing roles. Both the research topics themselves and the research techniques to carry out these investigations, form the basis of a strong collaboration within the JMBC.

2. Complex structures of fluids

Research in this Theme deals with complex structures of flow, formed in the presence of particles, drops, or bubbles, i.e., two- or even multi-phase flow. Two-phase flow is of paramount importance in contemporary science and technology.

One can readily cite a multitude of examples: the production and transport of oil (where bubbles are purposely injected to help lift thick heavy oil to the surface, or arise due to the release of dissolved gases), energy generation (where boiling is the key process in producing the steam to drive turbines), the chemical industry (where gas-liquid reactors rely on bubbles to increase the contact area between the phases), the oceans (where breaking-wave generated bubbles are important sinks for atmospheric CO₂), sedimentation (where sinking sand particles determine the morphology of coastal regions), food-industry, and many others. The challenge in single-phase flow is to understand the complicated dynamics as governed by the Navier-Stokes equation. In two-phase flow, even the underlying dynamical equations are often not known. For example, it is still not well understood why bubbles repel each other when they are close to each other. But even when the microscopic interactions are known, it is often not clear how the macroscopic structure evolves from this microscopic interaction and the response to external forces.

In many cases instabilities are involved in the macroscopic structure formation process. Very complex self-organising patterns can evolve out of these instabilities. An important example is cluster formation in sedimenting particles and coherent structures in bubble columns and fluidised beds.

Related topics are flow-controlled nucleation and droplet growth processes in high-pressure natural gas, which have important technical applications in the natural gas industry. Different JMBC groups are involved in the design of new types of condensate separators and in the numerical description of swirling supersonic two-phase flows, while a dedicated facility has been developed in order to investigate these condensation processes experimentally in a well-defined way.

How to theoretically describe such a complex system? Two types of approaches have been described in literature: In the first type of approach, the particles/bubbles/drops are treated essentially as points, while no attempt is made to simulate their detailed response to the liquid dynamics.

The advantage of this approach is that many particles/bubbles/drops can be treated, but the price to be paid is a lot of ad-hoc modelling. Fluid dynamical simulations in which the particles/bubbles/drops are modelled through averaged equations also belong to this first type of approach. In the second type of approach the detailed interactions of the particles/bubbles/drops with the flow is simulated, paying the price that – at present – the surrounding flow cannot really be turbulent and that only “a few” objects can be treated, in particular, when the interfaces are allowed to deform, i.e., for free boundary problems (drops and bubbles).

One of the main objectives for the research in two-phase flow must be to bridge the gap between these two types of approaches and to carry out a detailed investigation of the interaction between one or a few particles/bubbles/drops and a nontrivial flow field. Another objective must be to better understand the macroscopic structure formation process out of the microscopic interactions, and thus the instabilities in two-phase flow. It is evident that these objectives can only be achieved through a joint experimental, theoretical, and numerical approach.

On the experimental side, the challenge has always been to monitor and document as much information on the dynamics of the flow field as possible. Through the huge advances in both digital imaging techniques and information technology (see also Research Theme 1), the field is now flourishing, and the research on two-phase flow will strongly benefit from this. The same is to be expected from the advances with numerical techniques (see Research Theme 3), as brute force numerics will not be sufficient to address the problem of structure formation in two-phase flow. New algorithms and techniques are required and moving toward parallel computing is essential.

3. Mathematical and computational methods for fluid flow analysis

Advanced mathematical and computational techniques have become indispensable instruments for the description and understanding of complicated flow phenomena. This approach to fluid mechanics has evolved into a full-fledged counterpart to the experimental approach and provides new insight in complex flow physics, in for instance turbulence, combustion, multi-phase and rheological flows.

The use of computational flow models is supported with analytical techniques, which provide deeper insight in canonical flow problems, and strongly interacts with advanced experimental techniques, which are capable of measuring and visualizing complex three-dimensional unsteady flow fields. These techniques require advanced post-processing of the flow field data to understand the flow dynamics and have developed into a research subject in itself. Here tools from non-linear dynamical systems theory can be useful, as well as the decomposition of flow data through POD and wavelet analysis.

The rapid increase in computational power has significantly stimulated the use of computational techniques in flow analysis, but the development of better algorithms has been the most important source for improved numerical techniques for flow analysis.

Many flows are, however, simply too complex for computational techniques and flow modelling remains an essential issue. Compromises have to be found between the inaccuracies in flow modelling and computational constraints. In areas such as turbulent flow simulation much progress has been made through refined modelling via Large-Eddy Simulation (LES) and Direct Numerical Simulation (DNS). There is also an interest for stochastic methods, such as the use of the Langevin equation for the velocity. In the other areas the same trends have become feasible, e.g. PDF modelling in combustion and Brownian Dynamics in rheology.

It can be foreseen that the improvements in numerical algorithms and the growing computational power will open up new applications of flow analysis in other disciplines, such as chemistry, biomedicine and structural mechanics, and will continue to grow in importance. This will be stimulated by the development of new numerical techniques which can efficiently capture flow structures with large differences in length and time scales, the continuous increase in computing power, and by exploiting computational fluid dynamics in multi-physics applications.

REVIEW OF PROGRESS IN RESEARCH PROJECTS

As usual in the scientific community, progress in the research projects is reported in the form of PhD theses, journal publications, contributions to conference proceedings, (chapters of) books, and in the form of presentations at conferences. Only the refereed scientific output of the JMBC groups of 2015 is presented in this Annual Report 2015, as part of the group descriptions.

In a number of industry-funded projects, some of the JMBC groups produce output in the form of special reports for industries and technological institutes. These reports are not included in the groups' output presented in the Annual Reports. For more information, please contact the relevant project leaders.

OVERVIEW OF THE CONTRIBUTION OF THE PARTICIPATING GROUPS OF THE JMBC PER 1 JANUARY 2016

University and (sub)faculty	Scientific staff (fte)	Support staff (fte)	PhD students (fte)
TUD			
Mechanical Engineering			
BJ Boersma	2.8	-	4.0
J Westerweel, DJEM Roekaerts, RAWM Henkes, W van de Water	3.88	2.0	13.6
Maritime Engineering			
RHM Huijsmans, TJC van Terwisga	3.22	3.0	8.4
C van Rhee.....	0.78	0.5	4.0
Applied Mathematics			
C Vuik, C Oosterlee	2.4	-	8.0
AWH Heemink, E Deleersnijder	2.8	-	8.0
Chemical Engineering			
CR Kleijn, RF Mudde, HEA van den Akker, A de Haan, K Hanjalic	6.7	2.5	8.8
M Kreutzer, JR van Ommen	1.4	-	3.2
Radiation Science & Techn.			
THJJ van der Hagen (M Rohde)	1.1	2.0	4.0
Aerospace Engineering			
H Bijl, F Scarano, S Hickel	5.06	5.0	26.4
Civil Eng. & Geosciences			
AJHM Reniers, JD Pietrzak, WSJ Uijtewaal, GS Stelling, JC Winterwerp	7.4	-	13.6
HJJ Jonker, AP Siebesma	0.6	-	-
TUE			
Applied Physics			
AA Darhuber, J Snoeijer	0.76	0.6	4.0
HJH Clercx, GJF van Heijst, F Toschi, BJ Geurts	3.64	-	12.8
OCG Adan	0.9	-	4.0
GWM Kroesen, V Banine, U Ebert.....	4.9	3.0	10.4
Mechanical Engineering			
NG Deen, LPH de Goey, JGM Kuerten, M Golombok	8.9	3.6	16.8
DMJ Smeulders, EH van Brummelen, HA Zondag	5.1	4.0	20.8
JMJ den Toonder	5.1	-	4.0
Biomedical Engineering			
FN van de Vosse	0.15	-	0.8
Mathematics and Computer Science			
B Koren, MA Peletier, JJM Slot.....	2.7	-	4.8
Chemical Eng. & Chemistry			
JAM Kuipers	3.1	2.5	22.4
M van Sint Annaland	2.0	-	4.0

University and (sub)faculty	Scientific staff (fte)	Support staff (fte)	PhD students (fte)
UT			
Applied Physics			
D Lohse, JF Dijkman, J Harting, D van der Meer, A Prosperetti, J Snoeijer, R Verzicco			
L van Wijngaarden, M Versluis, X Zhang	16.12	4.8	26.4
F Mugele	1.1	1.0	5.6
Chemical Engineering			
RGH Lammertink	1.3	-	6.4
Mathematical Sciences			
EWC van Groesen.....	2.0	-	0.8
JJW van der Vegt	1.3	-	0.8
BJ Geurts, JGM Kuerten	0.4	0.2	2.4
Mechanical Engineering			
CH Venner, HWM Hoeijmakers	2.4	-	0.8
ThH van der Meer, G Brem.....	3.55	-	3.2
S Luding	5.9	-	6.4
Water Engineering & Manag.			
SJMH Hulscher.....	5.5	3.0	11.2
RUG			
Mathematics			
RWCP Verstappen, AEP Veldman	1.7	-	5.6
WUR			
Experimental Zoology			
JL van Leeuwen.....	0.7	-	1.6
Agrotechnology & Food Sciences			
CGPH Schroen.....	0.3	-	0.8
UU			
Physics			
H Dijkstra, LRM Maas	1.4	-	2.4

The calculation of fte's is based on: Professor 0,3 fte | Part-time professor 0.1 fte | Associated professor and assistant professor 0,4 fte | post-doc 1,0 fte | Support Staff 1.0 | PhD-student 0,8 fte

OVERVIEW OF UNIVERSITY PARTICIPANTS

	TUD	TUE	UT	RUG	WUR	UU	Total
Scientific staf	38.4	35.95	38.57	1.7	1.0	1.4	117.02
Support staff	15.0	13.7	9.0	-	-	-	37.7
PhD-students	102	104.8	64	5.6	2.4	2.4	281.2

INDUSTRIAL BOARD

It is a privilege to contribute to the Annual Report of the J.M. Burgers Centre (JMBC), the research school for fluid dynamics in The Netherlands, as the chair of the Industrial Board.

In 2014 was looking forward to continue the collaboration, and that worked out fine in 2015. The list of industrial members with interest of fluid flow is still strong and the variety wide, all the way from food to energy and from marine applications to process industries.

As Industrial Board we organized a workshop with indeed almost all industries from the board present, and we also invited STW and FOM, who are now formally represented in the Industrial Board. We condensed the outcome of this workshop into a few areas of interest, including rheology, diagnostic techniques, flow in porous media, and acoustics.

After the successful workshop 'Controlling multi-phase flow' in Amsterdam in 2014, a couple of industries took the initiative to start sketching a research program regarding the rheology effects of emulsions. The program is aiming to dive deeper into the rheology aspects at the interface between the liquid phases in emulsions, as well as the bulk rheology aspects which for instance are important for determining the pressure drop during transport through pipelines. The program is co-developed with ISPT and FOM. During the selection process of projects we will not close our eyes for initiatives from outside The Netherlands.

As can be seen from these examples, we are seeking interaction between industries, universities, and institutes, and push for interaction with other disciplines like process engineering, materials, mechanical engineering, etc.

Another fruitful year, and we hope to see the landing of at least one new program in 2016.



Dr.ir. P Veenstra
Shell
Chairman of the Industrial Board



Prof.dr.ir. RAWM Henkes
Delft University of Technology



Prof.dr.ir. NG Deen
Eindhoven University of Technology



Prof.dr.ir. RWCP Verstappen
University of Groningen



Prof.dr. DJEM Roekaerts
Delft University of Technology

CONTACTGROUP “MULTIPHASE FLOW”

The objective of the contact group Multiphase Flow is to stimulate interaction and collaboration between researchers, developers, and users in the area of multiphase flow from universities, institutes and industries. This is done through organizing regular meetings (once or twice per year) aimed at getting to know each other's activities and to learn about developments and applications of multiphase flow technology. This will provide a good forum to identify the needs of the users and to bring to the attention new possibilities for applying multiphase flow research results. Industry, a research institute or a university in turn act as host of the meetings. The program consists of a series of lectures on a specific theme and a visit of some of the local multiphase flow facilities. Examples of themes covered are: dynamic multiphase flows, multiphase flows with surface-active agents, and innovation with multiphase flow. On 2 November 2015 a very successful one-day meeting was held at the Physics of Fluids group at the University of Twente, with the theme “Multiphase Flow Fundamentals”, with 7 technical presentations and a visit to the Twente water channel and the Taylor-Couette setups.

Contacts: Prof.dr.ir. RAWM Henkes (TUD), Prof.dr.ir. NG Deen (TU/e)

CONTACTGROUP “COMPUTATIONAL FLUID DYNAMICS (CFD)”

Computational Fluid Dynamics (CFD) forms a rapidly advancing discipline that studies flow phenomena in science and engineering by means of computer simulation. Its basic principles are presented in a series of well-attended JMBC PhD courses: CFD 1, 2, and 3. The aim of the contact group is to exchange knowledge and experience in developing and applying CFD methods. To that end the CFD contact group organizes an annual meeting which provides a platform for discussing the latest developments as well as an opportunity for contacting CFD researchers from various areas (universities, research labs and industry). Especially, recently appointed (assistant) professors and third/ fourth-year PhD students will be given the opportunity to present their research achievements and users of CFD-techniques are invited to present their applications and challenges.

Contact: Prof.dr.ir. RWCP Verstappen (RUG)

CONTACTGROUP “COMBUSTION”

The contact group combustion forms an informal network between the groups active in combustion in Delft, Eindhoven, and Twente, bringing together the researchers in the Netherlands, in an international context.

About every three years the contact group combustion organizes the JMBC Course on Combustion, bringing PhD students, and other academic and industrial researchers to the forefront of experimental, theoretical and numerical research on fundamental and applied combustion. The latest edition took place in January 2016, and was organized in association with ERCOFTAC and the International Combustion Institute.

Since many years the JMBC groups also play an important role in the organization of the annual COMBURA symposium. This symposium is the major annual event in the Netherlands for exchange of information on combustion research and its applications.

Its goal is to enhance the mutual collaboration between the different academic and industrial researchers and to interest more industrial parties for the fundamental research on combustion. In 2015, COMBURA took place in Soesterberg on October 7 and 8 with keynote lectures by Univ.-Prof. Dr.-Ing. Stefan Pischinger (RWTH Aachen) and by Prof. Dr. Simone Hochgref (University Cambridge) and interesting program of oral and poster presentations on the research by the participants.

Contact: Prof. dr. DJEM Roekaerts (TUD)

CONTACTGROUP “LATTICE-BOLTZMANN TECHNIQUES”

The JMBC contact group on Lattice-Boltzmann Techniques was first established in 2002. The Lattice-Boltzmann schemes can be seen both as flexible and efficient solvers for macroscopic fluid equations or as particle-based simulation techniques which make close contact with the kinetic theory of gases. It is this last feature that allowed, in recent years, the partial disclosing of the huge potential of the method. The Lattice Boltzmann method has demonstrated great accuracy and performance in dealing with multiphase and multicomponent flows, from laminar to turbulent, in presence of simple or complex boundary conditions. The contact group promotes the organisation of educational and research events.

Contact: Prof.dr. F Toschi (TUE)



Prof.dr. F Toschi
Eindhoven University of Technology



Prof.dr.ir. BJ Boersma
Delft University of Technology



Dr.ir. WP Breugem
Delft University of Technology



Prof.dr.ir. J Westerweel
Delft University of Technology



Prof.dr. M Versluis
University of Twente

CONTACTGROUP “TURBULENCE”

Turbulent flows are omnipresent in industrial applications and the environment. Owing to the non-linear character of the governing Navier-Stokes equations, the structure and dynamics of turbulence is complex. It is for these reasons that turbulence has been studied for already more than a century, in particular after the pioneering work of Osbourne Reynolds on transition and turbulence in pipe flow. While early research focused on understanding of turbulence in single-phase flow, research on turbulence nowadays addresses a much broader class of turbulent flows such as e.g. turbulent multiphase flows, turbulent reacting flows, turbulence in supercritical fluids, etc, which complicates matter.

The contactgroup “Turbulence” organizes annual meetings between researchers of the JM Burgerscentrum active in the field of turbulence with the aim to strengthen contact between them and to exchange results and experience. PhD students and other researchers are given the opportunity to present their results in an informal setting that promotes discussion. The meetings take about a day with a program consisting of typically 7-8 talks from different researchers/groups, usually followed by a tour through the laboratory of the hosting institute and a “borrel” at the end of the day. The program of a meeting typically covers both fundamental and applied research topics as well as the development of experimental techniques and numerical simulation methods for turbulent flows.

Contacts: Dr.ir. WP Breugem (TUD), Prof. dr.ir. BJ Boersma (TUD)

CONTACTGROUP “EXPERIMENTAL TECHNIQUES”

The Contact Group Experimental Techniques forms a platform where experiments and experimental techniques can be discussed and evaluated. The main function of the contact group is to organize meetings in which the practice of experimenting can be discussed. An important contribution of the contact group is the organization of the JMBC course on Experimental Techniques in Fluid Mechanics. The course is very popular among the JMBC members as it gives a broad overview of advanced experimental techniques commonly used in fluid mechanics laboratories. The next course will be held 3-7 April 2017 at the University of Twente.

Contacts: Prof.dr. Michel Versluis (UT), Prof.dr.ir. J Westerweel (TUD)

CONTACTGROUP “BIOLOGICAL FLUID MECHANICS”

More and more research is conducted at the border between biology and fluid mechanics. This happens within many disciplines, from physiology (e.g. the interaction between blood flow and vessel walls) to aerodynamics (e.g. flapping flight). However, all deal with the interaction between fluids and a complex, changing geometry. One of the main challenges is to bridge the gaps between physics (esp. fluid mechanics) and medical and health sciences. To stimulate this relatively young field of research and bring together researchers, a new contact group was started in 2006. While the contact group is formally a part of the J.M. Burgerscentrum, the participation from researchers from non-affiliated universities, medical centers and institutes is encouraged. The Bio-Fluid Mechanics course (March 2009: about 40 participants) was jointly supported by the JM Burgers Centre and the ERCOFTAC organization by advertising the course amongst their members, via the website and by some financial means. Topics included: a recap of basics of fluid mechanics, external flows (swimming and flying, interaction of plankton and turbulence), internal flows (microcirculation, hemodynamics in large arteries, flow in flexible tubes, respiratory system, etc.). Examples of relevant experimental techniques, as well as simulation techniques were discussed. In case of a sufficient amount of interest a new course can be planned in the coming period.



Prof.dr.ir. F van de Vosse
Eindhoven University of Technology



Dr.ir. C Poelma
Delft University of Technology



Prof.dr. F Mugele
University of Twente



Prof.dr. J den Toonder
Philips Research
Eindhoven University of Technology



Prof.dr.ir. J Westerweel
Delft University of Technology

CONTACT GROUP “MICROFLUIDICS”

The contact group “Microfluidics” was established in 2005. The purpose of the contact group is to bring together students and postdocs interested in fluid dynamic aspects of microfluidics and give them a forum for presenting their results and exchanging ideas. Also, the contact group serves as a platform to exchange information about relevant conferences, workshops, courses, and research grant opportunities. Topics of interest include wetting and capillarity-driven flows, two-phase flow, micro-mixing, drop generation and control, emulsification, contact line dynamics, flow visualization, and measurement techniques. Attention is also given to also related applications such as microfluidic devices for medical diagnostics, water quality monitoring, and advanced cell culture systems. Students and researchers who are interested in the activities of the group and want to attend our symposia, are invited to contact the organizers of the contact group and have their name added to the mailing list. Members of the contact group organize the JMBC course “Capillarity-driven flows in microfluidics”, which is held at regular intervals

Contacts: Prof.dr. F Mugele (UT), Prof.dr. JMJ den Toonder (TUE), Prof. dr.ir. J Westerweel (TUD)

BURGERS PROGRAM FOR FLUID DYNAMICS AT THE UNIVERSITY OF MARYLAND

Inspired by the intellectual heritage of Johannes M. Burgers, who had a second career (1955 - 1981) at the University of Maryland after his retirement at the Technical University of Delft, the mission of the Burgers Program for Fluid Dynamics is to enhance the quality and international visibility of the research and educational programs in fluid dynamics and related areas at the University of Maryland, in partnership with the J.M. Burgerscentrum (JMBC). Fluid dynamics in this context is viewed to include a broad range of dynamics, from nanoscales to geophysical scales, in simple and complex fluids. The establishment of the Burgers Program was celebrated with an inaugural symposium at the University of Maryland in November 2004. Gijs Ooms, then Scientific Director of the JMBC, gave a lecture on the life and legacy of Burgers on that occasion. The interdisciplinary Burgers Program encompasses almost 80 faculty members spread over 22 different units in the College of Computer, Mathematical and Natural Sciences and the A. James Clark School of Engineering. For detailed information go to <http://www.burgers.umd.edu/>.

There have been numerous faculty and student exchanges between groups of the JMBC and the Burgers Program. Visitors to Maryland have come from the Technical Universities of Delft and Eindhoven, Leiden University, Twente University, and Utrecht University. Over thirty journal articles have resulted from these exchanges. At the annual Burgers Symposium in November of each year, the Burgers Lecture has been given by JMBC faculty: Frans Nieuwstadt, Bruno Eckhardt, Gijs Ooms, Detlef Lohse, Wim van Saarloos, Kees Vuijk, Wim Briels and Henk Dijkstra as well as by several others from France, Germany and the United States. Each spring semester the Burgers Program holds a Ph.D. student/Post-doctoral Fellow showcase Symposium, together with fluid dynamics groups from Johns Hopkins University and George Washington University. Five or six seminars are offered each academic semester in the Fluid Dynamics Reviews series. Beginning in 2010, the Burgers Program also began offering advanced level, week-long Research Summer Schools. The subjects have been Topics in Turbulence (twice), Granular Flows - from Simulations to Astrophysical Applications and Data Assimilation in the Geosciences. Students from the JMBC have participated in each of these.

Prof. Jim Wallace
Burgers Program Maryland (USA)
James M Wallace, Professor, Dept. of Mechanical Engineering



Prof.dr. JM Wallace
University of Maryland

HIGHLIGHTS

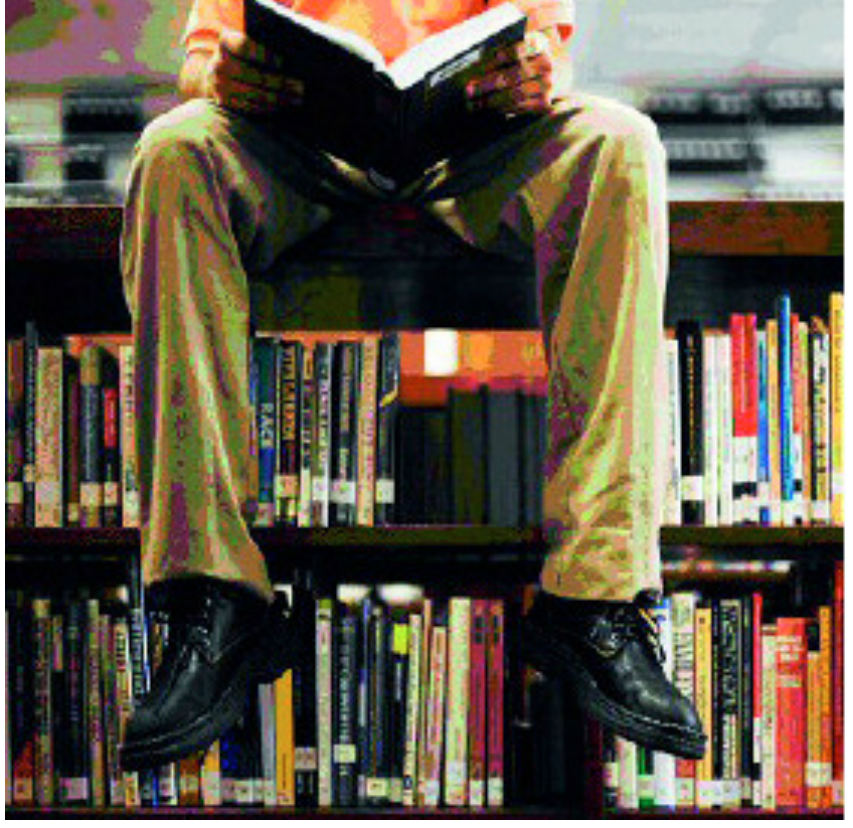



MAGNETIC ARTIFICIAL CILIA GENERATE MICROFLUIDIC FLOW

Ye Wang, Ruth Cardinaels, Patrick Anderson, Jaap den Toonder
Department of Mechanical Engineering, TU/e

Cilia are microscopic hairs (typically tens of micrometers long) that can be found in nature in which they provide the function of generating (microfluidic) flows (see Fig. 1). One example is the propulsion of microorganisms that are covered with thousands of cilia oscillating asymmetrically in a concerted fashion. Another example are the cilia that cover the inner walls of the human lungs and the windpipe, to sweep mucus and dirt out of the airways in order to avoid infections. Inspired by these biological examples, we have developed a range of different types of “artificial cilia”, hair-like micro-actuators that can be used to pump or mix fluids when integrated in microfluidic devices. They can be made to respond to various stimuli, such as electric field, light and magnetic field, and some of them have been shown to produce effective fluid pumping and mixing [1].

However, the fabrication techniques adopted in making those functional artificial cilia involved either microfabrication techniques under cleanroom conditions, or the use of expensive sacrificial materials as molds. As a result, effective but expensive prototypes were made and they have little prospect to be used in commercial microfluidic applications. Recently, we have reported novel techniques to produce magnetic artificial cilia in out-of-cleanroom settings [2,3]. Especially the “roll-pulling” method we developed has great potential as a cost-effective method to create effective magnetic artificial cilia [4,5].

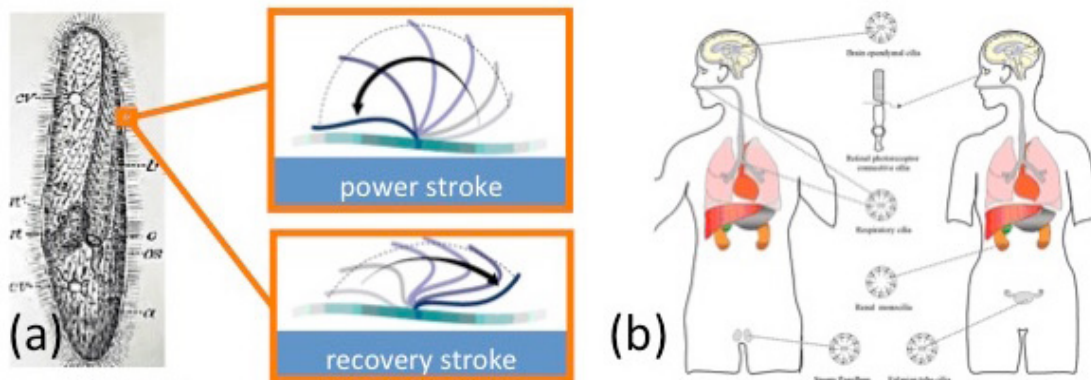

Figure 1: Examples of cilia found in nature. (a) Micro-organisms like paramecium are covered with microscopic hairs, cilia, that oscillate asymmetrically, so that they are able to propel the microorganism. (b) In our own bodies, cilia are present at a number of locations where they provide fluid flow, such as in our lungs and in our reproductive system.

An in-house-developed rolling setup was used to fabricate artificial cilia (Fig. 2a). The setup features a synchronized movement and an adjustable gap between the aluminum roll and the substrate holder. A poly(dimethylsiloxane) (PDMS) film with micropillars (Fig. 2b) is wrapped around to the roll. A substrate covered by a 200 μm thick liquid PDMS based precursor film containing iron particles travels beneath the roll and filaments are pulled out from the film by the micropillars. These filaments reach a certain critical length before breaking, creating artificial cilia on the substrate. Silica nanoparticles and a polyethylene oxide/PDMS block copolymer were added into the precursor to give the mixture exactly the right rheology, which is crucial for the formed artificial cilia to resist collapsing after their formation. A pair of vertically aligned electromagnetic poles is fixed above and below the moving parts to provide a magnetic field during fabrication for the vertical alignment of the artificial cilia. As a result, cone shaped slender artificial cilia with a length of about 300 μm and an aspect ratio of about 10 are created (Fig. 2c).

We integrated the artificial cilia into a recirculation microfluidic chip made of PDMS to characterize their flow generation capacity. A rotating magnet was placed underneath the cilia with its rotation axis at an offset with respect to the location of the cilia. This way, a time-dependent magnetic field was generated that actuated the cilia to perform a tilted conical motion (Fig. 2d), which generated a net fluid flow in the chip in this low Reynolds number setting. The flow speed was then characterized by tracking freely buoyant particles in the fluid. As shown in Fig. 2e, at an actuation frequency of 20 Hz, a flow speed over 120 $\mu\text{m}/\text{s}$ was created in the flow chip.

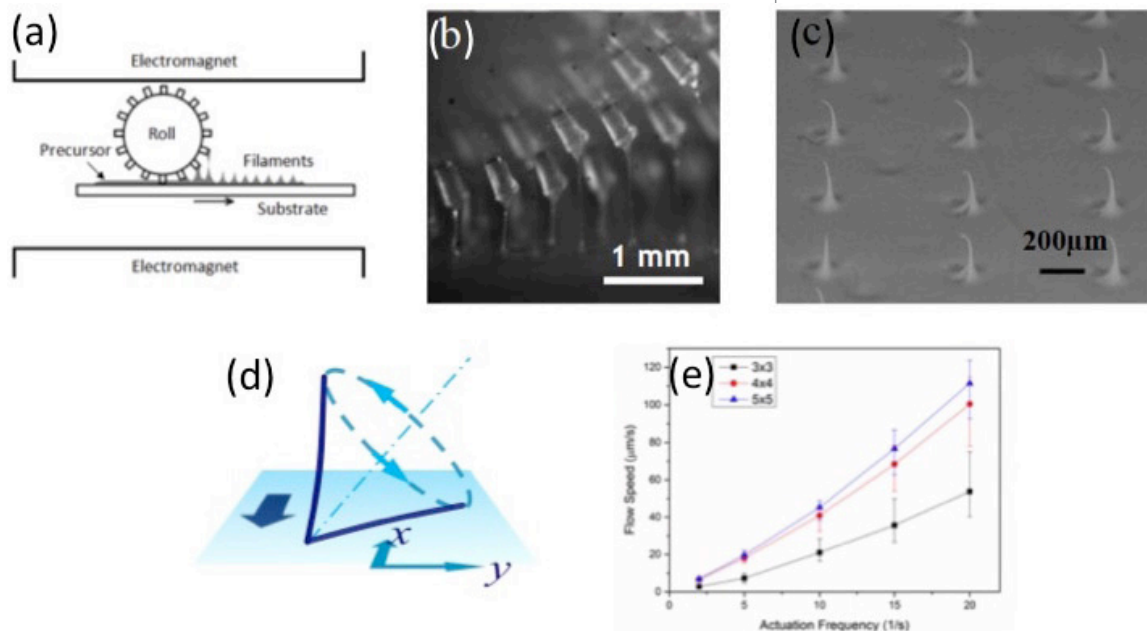

Figure 2: Our magnetic artificial cilia, made with “roll-pulling”. (a) Schematic of the roll-pulling setup; (b) liquid filaments being pulled out from the precursor film by micropillars, captured by high speed imaging; (c) micrograph of the resulting artificial cilia; (d) the artificial cilia are actuated with a rotating fields along a tilted cone; (e) flow speed generated by artificial cilia in a microfluidic channel actuated using a rotating external magnetic field, as a function of rotation frequency.

The effectiveness of our magnetic artificial cilia and the scalable and cost-effective production process make this work a promising technological platform for future studies. The ability of the artificial in manipulating fluids could also be used in other applications, for example in mixing of different fluids in a low Reynolds number setting, or in anti-fouling for submerged sensors by actively repelling contaminants from their surfaces.

References

1. Toonder, J.M.J. den & Onck, P.R. (2013). Microfluidic manipulation with artificial/bioinspired cilia. *Trends in Biotechnology*, 31(2), 85-91.
2. Wang, Y., Gao, Y., Wyss, H.M., Anderson, P.D. & Toonder, J.M.J. den (2013). Out of the cleanroom, self-assembled magnetic artificial cilia. *Lab on a Chip*, 13(17), 3360-3366.
3. Wang, Y., Gao, Y., Wyss, H.M., Anderson, P.D. & Toonder, J.M.J. den (2015). Artificial cilia fabricated using magnetic fiber drawing generate substantial fluid flow. *Microfluidics and Nanofluidics*, 18(2), 167-174.
4. Wang, Y., Cardinaels, R., Anderson, P.D. & Toonder, J.M.J. den (2016). A continuous roll-pulling approach for the fabrication of magnetic artificial cilia with microfluidic pumping capability. In preparation.
5. Wang, Y. (2016). Out-of-cleanroom magnetic artificial cilia. Eindhoven: PhD thesis, Technische Universiteit Eindhoven, ISBN 978-94-6259-979-6. ((Co-)promot.: Jaap den Toonder & Patrick Anderson).



THE AERODYNAMICS OF FLIGHT MANEUVERS IN FRUIT FLIES

Florian T. Muijres (Experimental Zoology Group, WUR)

Flying animals such as birds, bats and insects are extremely maneuverable, partly because their flapping wing flight platform is inherently unstable. Thus, in order to perform a rapid maneuver, the flapping wings need to produce only small amount of aerodynamic torque. We studied the maneuver dynamics of fruit flies using high-speed videography of freely flying flies and by using a physical aerodynamic model of a fruit fly[1,2]. Similar to many other insects and small birds, fruit flies flap their wings back and forth at a high wingbeat frequency (200 Hz). Throughout the wingbeat, the wings operate at very high angles of attack ($\sim 45^\circ$, Fig 1), which leads to the production of a Leading Edge Vortex (LEV) during each wing stroke. The LEV significantly boosts the aerodynamic lift required for weight support (Fig 1).

We studied two types of flight maneuvers in fruit flies, the body saccade and the evasive maneuver[1,2]. The body saccade (Fig 2A) is the sharp turn that flies produce at regular intervals during normal steady flight, and it is regarded as one of the most performed maneuvers found in nature[2]. The evasive turn (Fig 2B) is the very fast maneuver that is critical for survival because it is used to avoid collision and capture by predators[1].

We found that fruit flies control flight maneuvers very similar to helicopters. A fly primarily modulates the wingbeat-average aerodynamic force magnitude, of which the orientation remains roughly constant relative to the body (Fig 1).

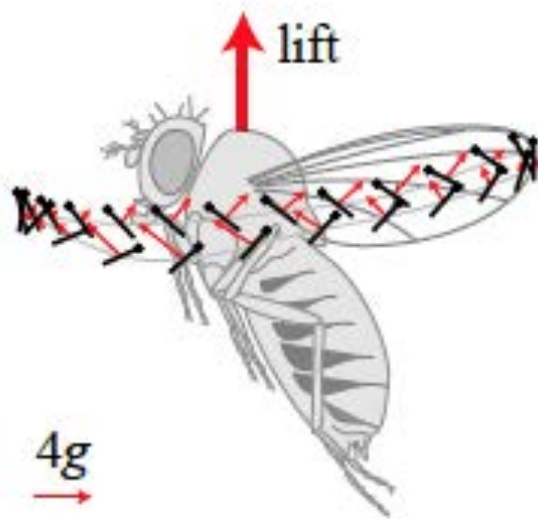

Fig 1. The wing kinematics depicted as lolly-pops and aerodynamic g-force vectors throughout the wingbeat of a hovering fruit fly. Adapted from Muijres et al (2014).

The direction of the aerodynamic force is controlled by body rotations around the three body axes, the roll, pitch and yaw axis (Fig 3). As a result, maneuvers in flies consist of a banked turn whereby flies bank to rotate the wingbeat average lift force in the desired direction of the turn and then rotate back again to continue straight flight (Fig 2A,B).

Although both saccadic and evasive maneuver consist of banked turns, the underlying control dynamics that allows a fly to regulate turn angle (i.e. how far the fly turns) is very different. During the initial phase of the body saccade, a fly rotates its body around a very stereotypic bank axis, which consists of roughly 65% body roll and 35% pitch up (Fig 2C). To regulate the turn angle of the saccade, a fly adjusts the amount of body rotation, whereby a larger banking rotation leads to a larger turn angle. The turn angle of evasive maneuvers, on the other hand, is not regulated by adjusting amount of rotation but by varying the ratio between the roll and pitch up components of the bank (Fig 2D). This roll-pitch ratio directly depends on the relative position of the danger that the fly is evading from, such that when an object approached the fly from the front the fly produces a pure pitch-up maneuver, and when the danger comes from the rear the fly produces pure roll during the banking maneuver (Fig 2D). The difference in control dynamics between the two maneuver types can be explained by the requirements of both maneuvers.

For the saccadic turn, the fly needs to perform a turn as controlled as possible, and so a highly stereotypic maneuver is preferred, i.e. always rotating around the same axis. For the evasive maneuver, the fly needs to escape as fast as possible and so the maneuver is performed at maximum banking rate. Therefore, controlling the turn through banking rate is not feasible, and so varying the direction of the banking axis is used instead.

By data-mining all studied maneuvers, we extracted the wingbeat kinematics changes responsible for controlling aerodynamic force magnitude and torque production about the roll, pitch and yaw axes. By replaying these kinematics on a dynamically-scaled robotic model of a fruit fly, we then modelled the underlying aerodynamic forces on the wings (Fig 3).

Fig 2. Comparison between the dynamics of a body saccade (A,C) and an evasive maneuver (B,D). (A,B) time lapse of flight maneuvers with flight velocity and normalized force production vectors overlaid. (C) aerodynamic torque vectors of the banking maneuver of all body saccades measured by Muijres et al (2015)[2]. (D) body rotation vectors of all evasive maneuvers measured by Muijres et al (2014)[1]. Vectors are color-coded depending on the orientation of the approaching danger as defined by the color band.

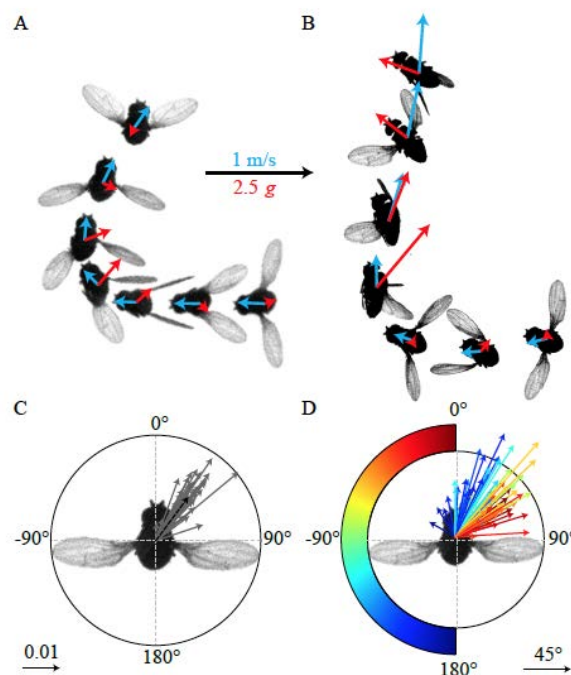

We found that fruit flies control aerodynamic force magnitude primarily by adjusting wingbeat amplitude and flap frequency (Fig 3A). Pitch torque is modulated by adjusting the position of stroke reversal at the end of the upstroke, which shifts the wingbeat-average force forwards and backwards with respect to the center of mass (Fig 3B). Roll torque is produced by moving one wing further up at the end of the downstroke. During the start of the consecutive upstroke, that wing produces a stronger downward plunge, resulting in a larger upwards directed drag force. The asymmetry in upward force between both wings results in a roll moment (Fig 3C). Yaw is produced by operating one wing at a higher angle of attack during the downstroke, but at a smaller angle of attack during the upstroke. This results in an asymmetry in drag force production between the two wings causing a net yaw torque throughout the wingbeat (Fig 3D).

Because the fly controls pitch and roll torque at the two opposite parts of the wingbeat, pitch and roll torque regulation is both spatially and temporally separated. This might simplify the control of relative pitch and roll torque during the fast evasive maneuvers. Also, the changes in wingbeat kinematics responsible for the studied flight maneuvers are strikingly small. This might contribute to the flies' ability to perform the very fast maneuvers that we measured, but it also means that the biological control actuators of the flight motor system need to be both very fast and precise to remain in control throughout not only the fast maneuver but even during inherently unstable straight flight.

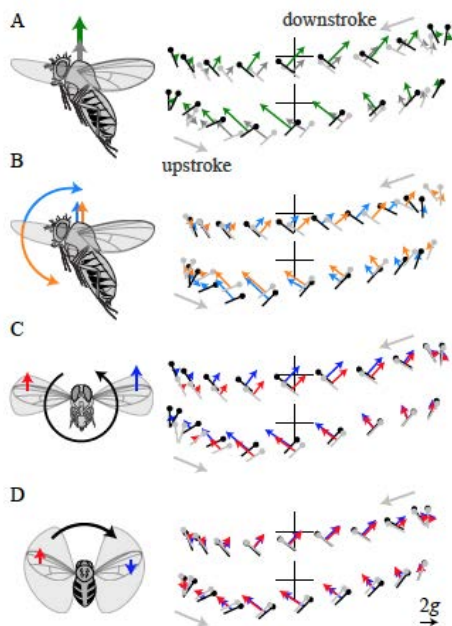

Fig 3. The wing kinematics and aerodynamic forces throughout the wingbeat of fruit flies that (A) produce an increased lift force (in green, the grey data is the hovering kinematics from Fig. 1), (B) pitch up and down torque (in light blue and orange, respectively), (C) roll torque, and (D) yaw torque. For clarity, the downstroke and upstroke kinematics are separated (the crosses depict the wing hinge position).

References

1. Muijres, F. T., Elzinga, M. J., Melis, J. M. & Dickinson, M. H. Flies Evade Looming Targets by Executing Rapid Visually Directed Banked Turns. *Science* 344, 172–177 (2014).
2. Muijres, F. T., Elzinga, M. J., Iwasaki, N. a. & Dickinson, M. H. Body saccades of *Drosophila* consist of stereotyped banked turns. *J. Exp. Biol.* 218, (2015).



MODELLING BARRIER COAST DYNAMICS

Pieter C. Roos (Water Engineering & Management, University of Twente), in collaboration with Henk M. Schuttelaars (TU Delft) and Ronald L. Brouwer (Flanders Hydraulic Research)

Barrier coasts, covering about 10% of the world's coastline, are often densely populated areas subject to potentially conflicting interests of economy, coastal safety and ecology. Barrier coasts typically display a chain of barrier islands, separated by tidal inlets that connect a back-barrier basin (lagoon) to a sea or ocean. These coasts are highly dynamic: the shapes of the islands, channels, ebb tidal deltas and tidal flats evolve continuously due to the complex interplay of tides, waves and sediment.

To study the long-term morphodynamics of such a multiple inlet system, we have developed an idealised morphodynamic model. In a schematised geometry, this model combines process-based formulations of tidal dynamics with empirical parameterisations of the tide- and wave-driven sediment transport in the inlet. Model simulations show the system's nonlinear evolution to an equilibrium state. As shown by an extensive sensitivity analysis, the model is able to reproduce the widely observed relationships between inlet spacing (indication of island length) and other system parameters: importance of tides relative to waves, width of the back-barrier basin.

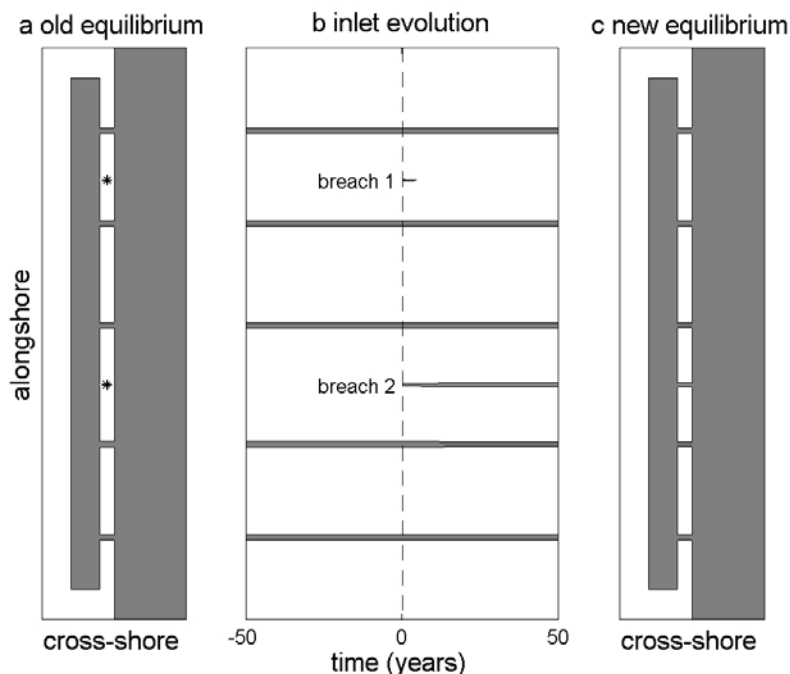

Example simulation with exploratory barrier coast model: (a) Top view of equilibrium state with back-barrier basin, connected by five inlets to a larger sea. To mimic a storm event, at $t=0$ two breaches are added to two of the barrier islands (stars). (e) Evolution, showing that one breach closes and the other stays open. (c) Top view of new equilibrium with six inlets. Basin length: 100 km, basin width: 2 km.

An exploratory model such as this one helps to understand the possible changes in the multiple-inlet configuration brought about by external factors, such as basin reduction, dredging activities, sea-level rise or storm-induced breaches (see figure). It stresses the interaction between basins and hence the need for an integral approach. This for example applies to the Wadden Sea. Wadden Sea management currently explores a policy shift allowing for more natural behaviour, by which the dynamics of the North Sea zone becomes part of the identity of the islands.

REFERENCES

1. P.C. Roos, H.M. Schuttelaars & R.L. Brouwer (2013), Observations of barrier island length explained using an exploratory morphodynamic model, *Geophys. Res. Lett.* 40, 1-6, doi:10.1002/grl.50843.
2. P.C. Roos, H.M. Schuttelaars & R.L. Brouwer (2014), invited presentation at NCK theme day on “The sediment balance of the Wadden Sea”, 10 October 2014, Leiden, The Netherlands.

GMW Kroesen, TU/e

Ceramic metal halide (CMH) lamps are the most efficient plasma lamps available for large scale and high power lighting purposes. Standard CMH lamps contain a small ceramic vessel that contains both mercury and metal-halide salts. The mercury is used to tune the arc voltage and the metal particles in the salts are responsible for the generation of the desired color. Due to regulations of the European Union the usage of the toxic species mercury is limited. In this work the feasibility of a mercury-free CMH lamp is investigated numerically using PLASIMO. Specifically, the replacement of mercury with salts like InI, SnI, GaI and DyI is investigated. Via emission and absorption of radiation these species have a strong impact on the temperature profile. Additionally, the interplay between convection and diffusion may introduce a color segregation which was observed before in Hg containing CMH lamps, see Figure 1.

The consequences of removing mercury in a CMH lamp are significant. In a standard lamp the mercury pressure is significantly larger than the pressure of any other species. Due to the low ionization degree of the trace species the usage of Fick's law to describe the diffusion is a good approximation. In the investigated Hg-free lamps the molecules dissociate and ionize in the hot zone of the plasma. The result is that Fick's law is no longer valid. Instead, a coupled system of diffusion equations, the Stefan-Maxwell system, should be solved. In order to reduce the number of equations the species equations are rewritten in

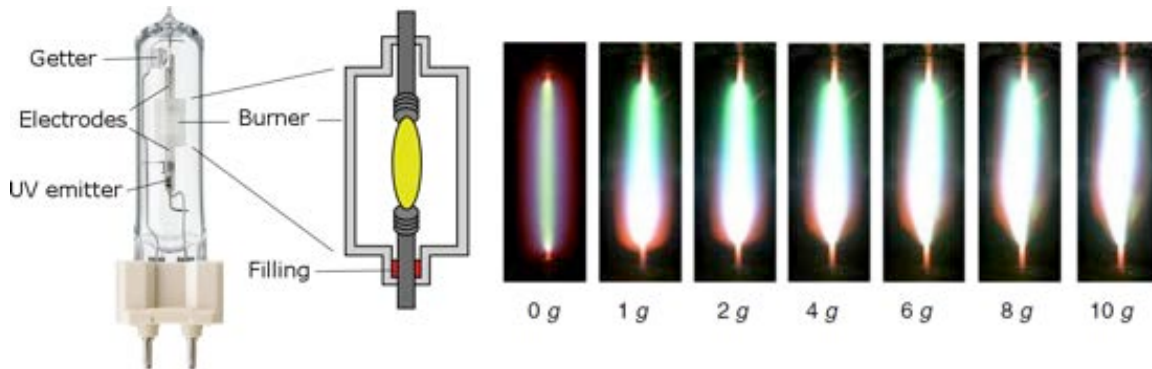

Figure 1. Left: An example of a CMH lamp. Right: Pictures of a Hg containing CMH lamp at various (artificial) gravity conditions. Different degrees of color segregation can be observed due to the interplay between convection and diffusion [5].

terms of a smaller amount of elemental equations. This is possible by applying the Guldberg-Waage relations.

This system is supplemented with two types of constraints. The first constraint regulates the amount of elemental mass in the gas phase. The second constraint deals with elements that are not fully evaporated. These elements are included using an elemental pressure at the liquid salt pool. A result of a calculation is shown in Figure 2. In the center of the discharge the species In and I occur in atomic and ionic form. Since In⁺ and I diffuse outwards faster than InI diffuses inwards the elemental amount of In is lower in the center than in the outer areas. A similar effect occurs for I and InI. However, the negative ion I⁻ does not follow the flux of the electrons and therefore the elemental amount of I reaches a maximum in the center. Another consequence of the slow inward flux of InI is that the species Xe is pushed towards the center.

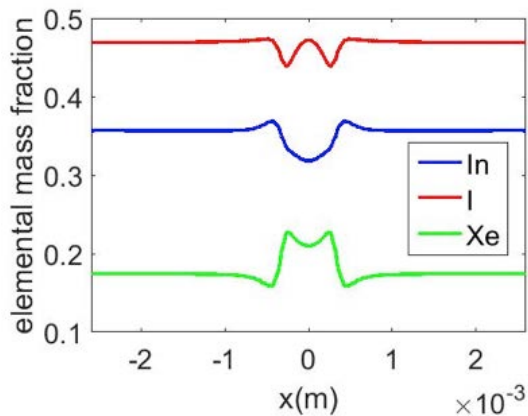

Figure 2. The elemental mass fractions of the species Xe, I and In.

Another consequence of replacing mercury is that input data for the suggested metal-halide species is much scarcer. For the purpose of calculating transport coefficients like the viscosity and the thermal conductivity accurate collision integrals are required. These collision integrals can be determined when the interaction potential between the species is known. Quantum-mechanical calculations using the software package DIRAC were able to deliver these results. This software package also aided in the calculation of radiative properties. The mercury containing lamp spectrum is mainly dominated by line radiation. The Hg-free lamp spectrum contains large contributions of associative radiation from In and I. These potential curves and the visible radiation that is emitted at a specific interatomic separation are shown in Figure 3.

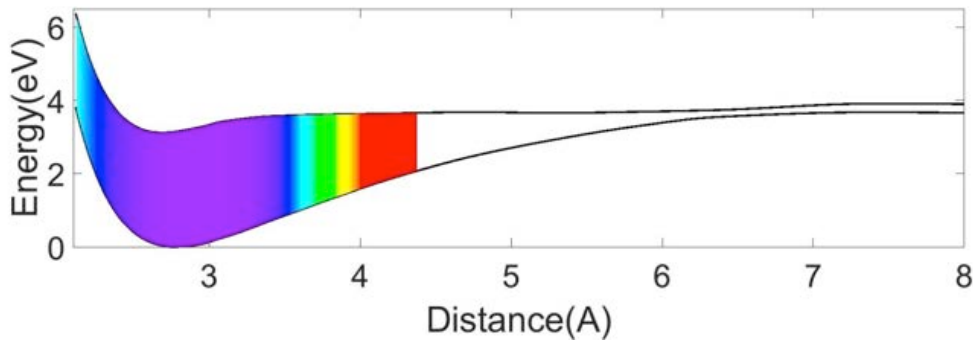

Figure 3. The calculated potential curves of InI that are involved in the associative continuum that dominates the lamp spectrum. The distance indicates the separation between the In and I atoms.

A simulation of a lamp also requires a calculation of the spectrum. This is done using the method raytracing. For several rays through the plasma the evolution of the emission and absorption events are integrated to estimate the radiative losses. A result of these losses for a lamp containing InI is shown in Figure 4. The image shows that all UV radiation is absorbed which is in agreement with measurements. Additionally, the continuum ranging from 400 to 1500 nm is reproduced.

REFERENCES

1. J.F.J. Janssen, K.S.C. Peerenboom, J.L.G. Suijker, and J. van Dijk. Modeling of diffusive plasmas in local thermodynamic equilibrium with integral constraints: application to mercury-free high pressure discharge lamp mixtures. Submitted to Journal of Physics D.
2. M. Gnybida, J.F.J. Janssen, J. van Dijk, J.L.G. Suijker, K.S.C. Peerenboom, A.J. Rijke, M. Gendre, and G.M.W. Kroesen. Numerical investigation on the replacement of mercury by indium iodide in high-intensity discharge lamps. Journal of Physics D: Applied Physics, 47(12):125201, 2014.
3. K.S.C. Peerenboom, J. van Boxtel, J.F.J. Janssen, and J. van Dijk. A conservative multicomponent diffusion algorithm for ambipolar plasma flows in local thermodynamic equilibrium. Journal of Physics D: Applied Physics, 47(42):425202, 2014.
4. J. van Dijk, K.S.C. Peerenboom, M. Jimenez-Diaz, D.B. Mihailova, and Joost van der Mullen. The plasma modelling toolkit PLASIMO. Journal of Physics D: Applied Physics, 42(19):194012, 2009.
5. A.J. Flikweert, T. Nimalasuriya, G.M.W. Kroesen, M. Haverlag, W.W. Stoffels, The metal-halide lamp under varying gravity conditions measured by emission and laser absorption spectroscopy. Microgravity Sci. Technol., 21:319–326, 2009.

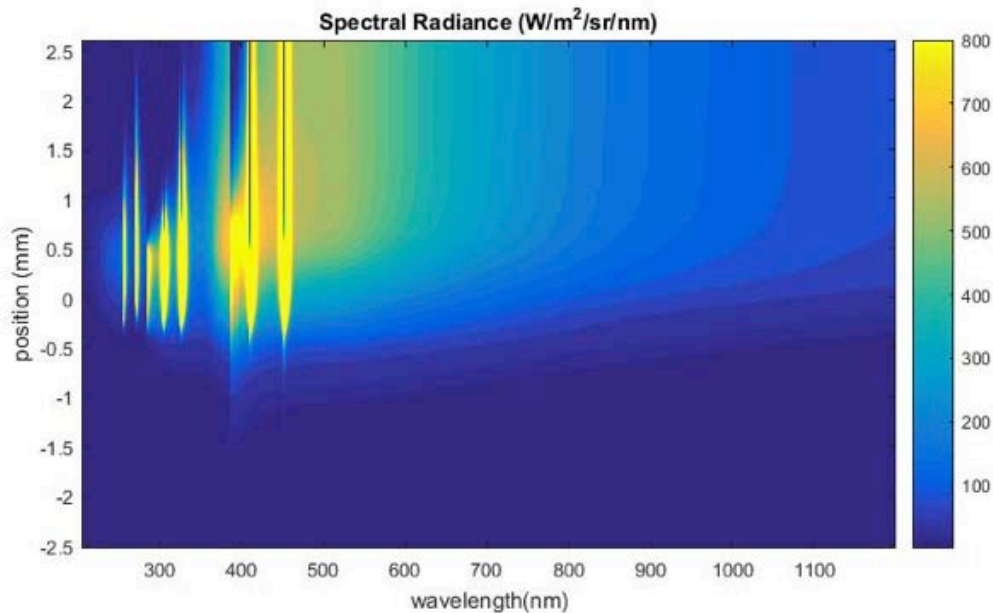

Figure 4. The calculated spectrum for an InI lamp. The spectrum is shown horizontally. The vertical coordinate shows the evolution of the spectrum (bottom to top) from wall to wall through the plasma.



RESEARCH





RESEARCH

INTRODUCTION

The research programme of the JMBC has been ordered in research themes and focal points. The reason for this ordering is to present a combination of projects which have coherence, either in terms of physical models or in terms of mathematical methods.

The main themes are:

1. Complex dynamics of fluids
2. Complex structures of fluids
3. Mathematical and computational methods for fluid flow analysis

DESCRIPTION OF THE RESEARCH THEMES

1. COMPLEX DYNAMICS OF FLUIDS

Fluid flows in the environment or in industrial applications are almost always characterised by some form of complexity. Frequently it is this complexity that makes the flow an interesting topic of research. Below we will sketch several examples of such flows and flow phenomena which form research topics carried out in the various groups of the J.M. Burgerscentrum.

The first form of complex dynamics which comes to mind is turbulence in contrast to a laminar flow. Here complexity appears in the form of strong non-linearity. Due to its chaotic behaviour turbulence can be considered as the archetype of a complex flow, and - being far from solved - turbulence will remain a strong focal point of research in the coming period. Turbulence research traditionally addresses the following questions:

- ♦ what are the physical processes and interactions governing turbulence,
- ♦ how can they be quantified and described mathematically,
- ♦ how to predict turbulence and turbulent flow for particular configurations, and
- ♦ how to control and manipulate turbulence?

Future research in this field in particular will focus on laminar-to-turbulent and reverse transition, effects of thermal buoyancy, unsteadiness, compressibility and rotation, and on the interaction with chemical reactions. The role of turbulence in energy conversion processes and equipment are regarded as an intriguing field of applications.

Complexity may also appear in the form of a combined flow of various phases. When these phases are immiscible, phenomena such as free surface flows occur. These may appear in the form of various wave phenomena, for instance on an unobstructed water surface, but also in a confined geometry of a pipe.

Another type of such flow of immiscible phases is when one of the phases is distributed in the form of small particles, bubbles or droplets in the other continuous phase. Various combinations of phases may be selected and each has its own particular problems. This class of flows, generally denoted as dispersed multi-phase flow, at the moment forms a strong focal point of research within the JMBC. The combination of phases that are miscible leads to other interesting problems such as mixing, and - depending on the fluids that take part in the mixing - chemical reactions or combustion.

Finally, complexity of the flow can also appear through its boundary conditions. For instance the flow geometry can strongly influence the flow characteristics by means of straining, shearing and distortion. An example is the wake behind a body in a shearing or straining flow.

Furthermore, the exact formulation of boundary conditions can have a consequence for the type of flow characteristics that appear.

An example is the free convection above a flat surface with a variable the conductivity. Geometry constraints on the flow are also dominant also when one considers a flow in 2D versus 3D. Here one should take as an example the quite different characteristics of 2D turbulence versus 3D-turbulence.

An increasingly important JMBC research activity within Theme 1 is aero-acoustics, aimed at the identification and quantification of acoustic sound sources in internal and external flows. Such sources can be related to unsteady vortex shedding, turbulence, combustion and flow-structure interaction. In general there is a strongly non-linear mutual interaction between sound source and acoustic field. The applications and technical implications show a great diversity. The JMBC is actively involved in vortex sounds in ducts, musical instruments (like the flute and the organ pipe), human speech, acoustics in burner stabilized flames, sound generation by turbulent flames, with much attention to analytical and numerical modelling of these flows.

The flow cases mentioned above, which are by no means an exhaustive list of complex fluid flow phenomena, form research topics in the various groups in the J.M. Burgers Centre.

The tools to carry out this research are primarily numerical and experimental. The numerical techniques used to compute flow phenomena are direct and large eddy numerical simulation, turbulence modelling and computational fluid dynamics. The experimental techniques used nowadays are mostly based on various forms of laser diagnostics (e.g. like PIV and PTV for flow measurements and CARS, LIF and Cavity Ring-Down Spectroscopy for temperatures and concentrations). Experiments, simulations and analytical theories in the field of fluid flow analysis complement each other - perhaps more than in other branches of physics. Future research will inevitably make use and take advantage of combined techniques and their complementing roles. Both the research topics themselves and the research techniques to carry out these investigations, form the basis of a strong collaboration within the J.M. Burgerscentrum.

2. COMPLEX STRUCTURES OF FLUIDS

Research in this Theme deals with complex structures of flow, formed in the presence of particles, drops, or bubbles, i.e., two- or even multi-phase flow. Two-phase flow is of paramount importance in contemporary science and technology.

One can readily cite a multitude of examples: the production and transport of oil (where bubbles are purposely injected to help lift thick heavy oil to the surface, or arise due to the release of dissolved gases), energy generation (where boiling is the key process in producing the steam to drive turbines), the chemical industry (where gas-liquid reactors rely on bubbles to increase the contact area between the phases), the oceans (where breaking-wave generated bubbles are important sinks for atmospheric CO₂), sedimentation (where sinking sand particles determine the structure of our coasts), food-industry, and many others.

The challenge in single-phase flow is to understand the complicated dynamics which is generated by the Navier-Stokes equation. In two-phase flow, even the underlying dynamical equations are often not known. E.g., it is not understood why bubbles repel each other when they are close to each other.

But even when the microscopic interactions are known, it is often not clear how the macroscopic structure evolves from this microscopic interaction and the response to external forces.

In many cases instabilities are involved in the macroscopic structure formation process. Very complex self-organising patterns can evolve out of these instabilities. An important example is cluster formation in sedimentating particles and coherent structures in bubble columns and fluidised beds.

Related topics are flow-controlled nucleation and droplet growth processes in high-pressure natural gas, which have important technical applications in the natural gas industry. Different JMBC groups are involved in the design of new types of condensate separators and in the numerical description of swirling supersonic two-phase flows, while a dedicated facility has been developed in order to investigate these condensation processes in a well-defined way experimentally.

How to theoretically describe such a complex system? Two types of approaches have been described in literature: In the first type of approach, the particles/bubbles/drops are treated essentially as points, while no attempt is made to simulate their detailed response to the liquid dynamics.

The advantage of this approach is that many particles/bubbles/drops can be treated, but the price to be paid is a lot of ad-hoc modelling. Fluid dynamical simulations in which the particles/bubbles/drops are modelled through averaged equations also belong to this first type of approach. In the second type of approach the detailed interactions of the particles/bubbles/drops with the flow is simulated, paying the price that - at present - the surrounding flow can not really be turbulent

and that only “a few” objects can be treated, in particular, when the interfaces are allowed to deform, i.e., for free boundary problems (drops and bubbles).

One of the main objectives for the research in two-phase flow must be to bridge the gap between these two types of approaches and to carry out a detailed investigation of the interaction between one or a few particles/bubbles/ drops and a nontrivial flow field. Another objective must be to better understand the macroscopic structure formation process out of the microscopic interactions, and thus the instabilities in two-phase flow. It is evident that these objectives can only be achieved through a joint experimental, theoretical, and numerical approach.

On the experimental side, the challenge has always been to monitor and document as much information on the dynamics of the flow field as possible. Through the huge advances in both digital imaging techniques and information technology (see Research Theme 3), the field is now flourishing, and the research on two-phase flow will strongly benefit from this. The same is to be expected from the advances with numerical techniques (see Research Theme 4), as brute force numerics will not be sufficient to address the problem of structure formation in two-phase flow. New algorithms and techniques are required and moving toward parallel computing will be essential.

3. MATHEMATICAL AND COMPUTATIONAL METHODS FOR FLUID FLOW ANALYSIS

Advanced mathematical and computational techniques have become indispensable instruments for the description and understanding of complicated flow phenomena. This approach to fluid mechanics has evolved into a full-fledged counterpart to the experimental approach and provides new insight in complex flow physics, in for instance turbulence, combustion, multi-phase and rheological flows.

The use of computational flow models is supported with analytical techniques, which provide deeper insight in canonical flow problems, and strongly interacts with advanced experimental techniques, which are capable of measuring and visualizing complex three-dimensional unsteady flow fields. These techniques require advanced post-processing of the flow field data to understand the flow dynamics and have developed into a research subject in itself. Here tools from non-linear dynamical systems theory can be useful, as well as the decomposition of flow data through POD and wavelet analysis.

The rapid increase in computational power has significantly stimulated the use of computational techniques in flow analysis, but the development of better algorithms has been the most important source for improved numerical techniques for flow analysis.

Many flows are, however, simply too complex for computational techniques and flow modelling remains an essential issue. Compromises have to be found between the inaccuracies in flow modelling and computational constraints. In areas such as turbulent flow simulation much progress has been made through refined modelling via Large-Eddy Simulation (LES) and Direct Numerical Simulation (DNS). There is also an interest for stochastic methods, such as the use of the Langevin equation for the velocity. In the other areas the same trends have become feasible, e.g. PDF modelling in combustion and Brownian Dynamics in rheology.

It can be foreseen that the improvements in numerical algorithms and the growing computational power will open up new applications of flow analysis in other disciplines, such as chemistry, biomedicine and structural mechanics, and will continue to grow in importance. This will be stimulated by the development of new numerical techniques which can efficiently capture flow structures with large differences in length and time scales, the continuous increase in computing power, and by exploiting computational fluid dynamics in multi-physics applications.

REVIEW OF PROGRESS IN RESEARCH PROJECTS

As agreed by the project leaders of the JMBC only doctoral thesis, (contributions to) books, and publications in scientific journals and in proceedings of conferences with a referee system, are given in the output for each project. Only 2015 publications are taken up in the project descriptions.

An important output for various JMBC-groups is in the form of special reports for industries, technological institutes, etc. Those reports are not mentioned in the output of the projects. For more information, please contact the relevant project leaders.



FLUID MECHANICS



Prof.dr.ir. J Westerweel



Prof.dr.DJEM Roekaerts



Prof.dr.ir. RAWM Henkes



Prof.dr.ir. W van de Water



Prof.dr.ir. BJ Boersma

Within the Department Process & Energy the chair of energy technology of prof. BJ Boersma, the chair of fluid mechanics of prof. J. Westerweel, and the chair of turbulent reacting flows of prof.dr. DJEM Roekaerts, are complemented by: dr.ir. WP Breugem, dr. R Delfos, dr.ir. GE Elsinga, dr.ir. W de Jong, dr. R Pecnic, dr.ir. C Poelma, dr.ir. MJBPM Pourquie, dr. D Tam, dr.ir. M Tummers, and part-time chairs: prof.dr. B Eckhardt, prof.dr.ir. RAWM Henkes, prof.dr. JCR Hunt FRS, and prof.dr.ir. G Ooms.

The common themes of the research in the department group are: (i) turbulence and complex flows, such as multiphase flows, microfluidics, biological flows, and fluid mechanics of sports, (ii) turbulence in supercritical fluids, rotating machinery and gas turbines, energy conversion processes, and aeroacoustics, and (iii) turbulent mixing in non-reacting and reacting flows, turbulence-chemistry-radiation interaction in flames, and turbulent heat transfer.

The research is aimed at fundamental aspects of flows, but always with a clear connection to a practical application or process in industry. Experimental and computational studies are made of systems at different scales, from lab-scale to industrial scale. Detailed investigations are made using laser diagnostic techniques (such as particle image velocimetry, laser-induced fluorescence, and other spectroscopic methods) and using advanced computational models, such as large-eddy simulation and direct numerical simulation. The program responds to a substantial drive from society and industry, for example for more environmentally friendly combustion processes avoiding the formation of NO_x and particulates (soot) in industrial combustion systems (furnaces, gas turbines, engines), and for the development of energy efficient processes (e.g., through drag reduction). The activities in microfluidic flows aim at the investigation of small-scale cardiovascular flows, flow geometries with complex boundary conditions (such as microflagella), and micro-scale multiphase flows.

MODELLING AND EXPERIMENTS FOR BY-PASS PIGGING WITH SPEED CONTROL

PROJECT AIM

A Pipeline Inspection Gauge (pig) is a cylindrical device that fits onshore or offshore pipelines for the transport of gas, oil, water in the oil and gas industry. The pig is launched at the inlet and received at the outlet. It is used for various purposes, such as water removal to prevent corrosion, removal of wax deposition along the pipe walls, removal of other solids, and inspection of the pipe wall condition. The use of a pig with an opening in the centre (a so-called by-pass pig) will allow some of the fast moving gas to flow through the pig during the pigging operation. The aim of this PhD project is to develop an optimum way to control the speed of the by-pass pig.

PROGRESS

PhD student Maurice Hendrix has spent part of his time at Delft University and part at the Shell Technology Centre Amsterdam. He has been supported by three Master students, who worked on (1) CFD modeling for by pass pigging, both for 2D and 3D single phase flow and also 3D twophase flow, (2) Wall friction modeling and small scale tests at Shell Amsterdam. The lab experiments at consist of pull tests to find the friction between the pig and the pipe, single phase flow through various typical by-pass configurations, which will give pressure loss coefficients due to the by-passing fluid.. (3) by-pass pigging experiments in the 130 m long, 2" diameter water/air flow loop at Delft University. The results from the CFD model and from the lab tests will be used in a simple 1D model for the by-pass pig that was implemented in the 1D time-dependent/spatial model for twophase pipeflow.

DISSERTATIONS

-

SCIENTIFIC PUBLICATIONS

1. Azpiroz, J.E., Hendrix, M.H.W., Breugem, W.-P., Henkes, R.A.W.M. CFD modelling of bypass pigs with a deflector disk, Proc. 17th Int. Conf. on Multiphase Technology, pp. 141-155, BHR Group, Cannes, 2015.
2. Groote, G.A., Van de Camp, B.J., Veenstra, P., Broze, G., Henkes, R.A.W.M. By-pass pigging without or with speed control for gas-condensate pipelines, SPE Paper 177819-MS, 2015.

PROJECTLEADERS

RAWM Henkes, WP Breugem

RESEARCHTHEME

Complex dynamics of fluids

PARTICIPANTS

MHW Hendrix, RAWM Henkes, WP Breugem

COOPERATIONS

-

FUNDED

Shell Global Solutions International
BV
University -
FOM -
STW -
NWO Other -
Industry 100 %
TNO -
GTI -
EU -
Scholarships -

START OF THE PROJECT

2013

INFORMATION

M Hendrix
06 50987039
M.H.W.Hendrix@tudelft.nl

CORE-ANNULAR FLOW

PROJECT LEADERS

G. Ooms & R.A.W.M. Henkes

RESEARCH THEME

Complex dynamics of fluids

PARTICIPANTS

E.M.R.M. Ingen Housz,
M.J.B.M. Pourquie, A. Kidess

COOPERATIONS

-

FUNDED

University	100 %
FOM	-
STW	-
NWO Other	-
Industry	-
TNO	-
GTI	-
EU	-
Scholarships	-

START OF THE PROJECT

2015

INFORMATION

EMRM Ingen Housz
0 628541746
e.ingenhousz@gmail.com

PROJECT AIM

The aim of the project is to investigate the core-annular flow of a very viscous oil and water experimentally and numerically. Comparison of the results will give new insights into the properties of the flow, such as the levitation mechanism and the drags experienced. Studying the influence of the fluid properties on the oil-core flow is another aim. That means carrying out experiments with different values of the density difference, core-viscosity and interfacial tension. Furthermore, various turbulence models will be considered in the numerical calculations. These turbulence models need to be investigated further in order to legitimate their usage.

PROGRESS

The new water-oil flow loop (7 m long, 21 mm diameter) has been built and its proper functioning has been verified. Systematic pressure drop and flow visualization experiments were carried out for a range of oil and water flow rates. The optimal water addition ratio has been determined, which is the ratio between the water and oil flow rate where the flow experiences the least wall friction. This optimal ratio is found to be constant for different values of the oil flow rate. Furthermore a relation between the pressure drop and the Froude number has been found.

The $k-\epsilon$ Launder-Sharma RANS-model has been used in OpenFoam for the numerical prediction of the core-annular flow at the experimental conditions. This gives better results than assuming a purely laminar flow in the model, as was used previously. Results with the Launder-Sharma model are also compared with OpenFoam simulations using the $k-\omega$ model and a LES approach.

DISSERTATIONS

-

SCIENTIFIC PUBLICATIONS

-

LIQUID ACCUMULATION IN NEARLY HORIZONTAL PIPELINES WITH MULTIPHASE FLOW AT LOW GAS PRODUCTION RATES

PROJECT AIM

The project aims at improving the basic understanding of a key aspect of multiphase flow in pipelines as used in the gas and oil industry, which is the liquid accumulation in systems under turndown operational conditions. The experimental lab configuration will consist of a V-shaped piece of pipeline, representing the low spot. The turbulence levels will be measured using Particle-image Velocimetry. The experimental data will be used to improve the one-dimensional models used in the gas and oil industry, as well as in the next generation type of models, based on three-dimensional Reynolds Averaged Navier Stokes (RANS) equations.

PROGRESS

A stratified two-phase flow of air and water was measured with Particle Image Velocimetry (PIV) in a horizontal transparent pipe, with a laminar, transitional or turbulent liquid, and a smooth or a wavy interface. An advanced experiment was designed and built, which uses two lasers and three cameras to simultaneously measure the liquid velocity, interface shape and gas velocity. The data were time and phase-averaged to obtain detailed and accurate insight into the turbulent and wavy structures. The interfacial characteristics and the velocities were investigated in both phases of stratified flow with two wave patterns: '3D small amplitude' and '2D large amplitude' waves. The 2D LA waves (corresponding to gravity waves) had higher and longer waves that changed the liquid velocities in almost the entire liquid layer. The 3D SA wave pattern (corresponding to gravity-capillary waves) had smaller and shorter waves whose influence was limited to only a part of the liquid height. The effect of the two wave regimes on gas phase velocities, however, was rather similar. In all cases, waves produced an increase in the Reynolds stresses in the air close to the interface, which was linked to the occurrence of boundary layer separation at the interface. The occurrence of separation correlated well with the wave properties.

DISSERTATIONS

1. M. Birvalski, Experiments in stratified gas-liquid pipe flow, PhD Thesis, Delft University of Technology, 2015.

SCIENTIFIC PUBLICATIONS

1. Sanderse, B., Haspels, M., Henkes, R.A.W.M. Simulation of elongated bubbles in a channel using the two-fluid model, *J. of Dispersion Science and Technology* 36, pp 1407-1418, 2015. DOI:10.1080/01932691.2014.989571.
2. Birvalski, M., Tummers, M.J., Delfos, R., Henkes, R.A.W.M, Laminar-turbulent transition and wave-turbulence interaction in stratified horizontal two-phase pipe flow. *J. Fluid Mech.* 780, pp. 439-456, 2015. DOI:10.1017/jfm.2015.483

PROJECT LEADERS

RAWM Henkes, MT Tummers,
R Delfos

RESEARCH THEME

Complex dynamics of fluids

PARTICIPANTS

M. Birvalski (PhD student)

COOPERATIONS

Shell

FUNDED

Shell

University 25 %

FOM -

STW -

NWO Other -

Industry 75 %

TNO -

GTI -

EU -

Scholarships -

START OF THE PROJECT

2010

INFORMATION

RAWM Henkes

06 52096201

R.A.W.M.Henkes@tudelft.nl

MITIGATION OF FLOW-INDUCED VIBRATIONS IN CORRUGATED PIPES BY MEANS OF LIQUID ADDITION

PROJECT LEADERS

C Poelma, J Westerweel

RESEARCH THEME

Complex dynamics of fluids

PARTICIPANTS

AC van Eckeveld

COOPERATIONS

Names of national and international cooperations (when relevant).

FUNDED

Shell	
University	-
FOM	-
STW	-
NWO Other	-
Industry	100 %
TNO	-
GTI	-
EU	-
Scholarships	-

START OF THE PROJECT

2013

INFORMATION

AC van Eckeveld
06 12644266
a.c.vaneckeveld@tudelft.nl
<http://delftpe.nl/node/792>

PROJECT AIM

Development of physical understanding on sound mitigation in corrugated pipes, with a focus on industrial circumstances. Aimed at providing input for design purposes of corrugated risers.

PROGRESS

Continuation of work on flat plate cavity. Development of numerical method, aimed at predicting geometrical effects from corrugated pipe flow. Construction of corrugated pipe set-up and first experiments in that set-up, both single and two-phase. Assessment of effect of liquid addition on the acoustic output. Combination of the

DISSERTATIONS

-

SCIENTIFIC PUBLICATIONS

1. C. van Eckeveld, A.K. Pancham, J. Westerweel and C. Poelma. Flow over a partially liquid filled cavity. 15th European Turbulence Conference, August 25-28 2015, Delft, The Netherlands

FULLY RESOLVED SIMULATIONS OF DENSE TURBULENT SEDIMENT TRANSPORT

PROJECT AIM

The aim of this PhD project is two-fold:

- 1) develop a state-of-the-art computational method for fully resolved simulations of dense particle-laden turbulent flows and
- 2) study the structure and dynamics of these flows with the developed method.

PROGRESS

We applied our numerical algorithm to massively parallel interface-resolved direct numerical simulations of turbulent channel transport of neutrally-buoyant spheres. From these we derived universal scaling laws for dense particle suspensions in turbulent wall-bounded flows. We also started to study turbulent bed-load transport.

DISSERTATIONS

-

SCIENTIFIC PUBLICATIONS

1. P. Costa, J. Westerweel, B. J. Boersma & W.-P. Breugem — Collision model for fully-resolved simulations of flows laden with finite-sized particles. *Phys. Rev. E* 92, 053012
2. F. Picano, P. Costa, W.-P. Breugem, L. Brandt — Mechanics of dense suspensions in turbulent channel flows. 15th European Turbulence Conference 2015 (ETC15)
3. P. Costa, F. Picano, L. Brandt, W.-P. Breugem — Universal Scaling Laws for Dense Particle Suspensions in Turbulent Wall-Bounded Flows. (submitted)

PROJECTLEADERS

WP Breugem, BJ Boersma,
J Westerweel

RESEARCHTHEME

Complex dynamics of fluids

PARTICIPANTS

PS Costa, WP Breugem,
BJ Boersma, J Westerweel

COOPERATIONS

-

FUNDED

FCT, The Portuguese Foundation for
Science and Technology

University -

FOM -

STW -

NWO Other -

Industry -

TNO -

GTI -

EU -

Scholarships 100 %

START OF THE PROJECT

2013

INFORMATION

PS Costa

015 278 4194

P.SimoesCosta@tudelft.nl

<http://www.pe.tudelft.nl/node/663>

DRAG REDUCTION IN WATERSPORTS

PROJECT LEADERS

J Westerweel

RESEARCH THEME

Complex dynamics of fluids

PARTICIPANTS

Ir. AJ Greidanus, dr.ir. R Delfos

COOPERATIONS

InnoSportNL, DSM, TNO, MARIN

FUNDED

InnoSportNL, DSM, MARIN

University -

FOM -

STW -

NWO Other -

Industry 100 %

TNO -

GTI -

EU -

Scholarships -

START OF THE PROJECT

2010

INFORMATION

A Greidanus

015 278 2904

A.J.Greidanus@tudelft.nl

www.ahd.tudelft.nl

PROJECT AIM

Friction of water is a large contributor to the total drag in water sports. Reducing this drag leads to higher velocities, which is all about in most water sports; Going faster! The friction can be reduced by changing the surface properties, due to coatings, which will influence the interaction between water and object. The project aim is to develop, characterize and testing specific coatings which will reduce this friction drag.

PROGRESS

The Taylor-Couette testing facility of the Laboratory for Aero- & Hydrodynamics at the Delft University of Technology proved to be useful to analyze the drag reducing effect of specific surfaces and products. The data with riblets show a similar trend and a maximum of 5% drag reduction. A rotation effect is observed for drag reducing surfaces. Self-developed coatings are characterized and tested on their drag reducing effect. Results expected in 2016.

DISSERTATIONS

-

SCIENTIFIC PUBLICATIONS

1. Greidanus, A. J., Delfos, R., Tokgöz, S., & Westerweel, J. (2015, March). Riblet drag reduction and the effect of bulk fluid rotation in a fully turbulent Taylor-Couette flow. In EDRFCM 2015: European Drag Reduction and Flow Control Meeting, Cambridge, UK, 23-26 March 2015. University of Cambridge.
2. Greidanus, A. J., Delfos, R., Tokgoz, S., & Westerweel, J. (2015). Turbulent Taylor-Couette flow over riblets: drag reduction and the effect of bulk fluid rotation. *Experiments in Fluids*, 56(5), 1-13.
3. Greidanus, A., Delfos, R., Tokgoz, S., & Westerweel, J. (2015, August). Experimental study of surface modification in a fully turbulent Taylor-Couette flow. In 15th European Turbulence Conference 2015 (ETC15), August 25-28th, 2015, Delft, The Netherlands.
4. Alidai, A., Greidanus, A. J., Delfos, R., & Westerweel, J. (2015). Turbulent Spot in Linearly Stable Taylor Couette Flow. *Flow, Turbulence and Combustion*, 1-11.

OPTIMIZATION OF PROPULSION IN AND OVER WATER

PROJECT AIM

In swimming and rowing (sports) improved athlete performance is obtained by real-time feedback to coaches and athletes. The objective is to maximize propulsion effectiveness by providing feedback about the hydrodynamics. To provide feedback flow characteristics enhancing propulsion are to be identified, quantified, and optimized. A method enabling real-time measurement of these characteristics is to be developed. Also a strong desire exists to measure the hydrodynamic losses, i.e. what amount of energy is dissipated in the water thus not increasing the kinetic energy of the boat/body.

PROGRESS

A literature study provided insight in the phenomena responsible for propulsion, e.g. lift, drag, vortex shedding. Further, requirements for an experimental setup able to replicate the rowing stroke have been formulated. An industrial robot capable of replicating the rowing stroke has been found. A prototype measurement oar is developed able to measure part of the relevant forces during a rowing stroke. Also two-dimensional numerical simulations are carried out to obtain insight in the vortex structures shed by the oar blade.

DISSERTATIONS

-

SCIENTIFIC PUBLICATIONS

-

PROJECTLEADERS

J Westerweel, MJ Tummers

RESEARCHTHEME

Complex dynamics of fluids

PARTICIPANTS

EJ Grift

COOPERATIONS

Koninklijke Nederlandse Roeibond, (KNRB), Koninklijke Nederlandse Zwembond (KNZB), Technologiestichting (STW), TU Eindhoven, VU Amsterdam

FUNDED

STW, KNRB, KNZB, InnosportLab.
University -
FOM -
STW 50 %
NWO Other -
Industry 50 %
TNO -
GTI -
EU -
Scholarships -

START OF THE PROJECT

2014

INFORMATION

EJ Grift
015 278 1123
e.j.grift@tudelft.nl
pe.tudelft.nl

HYDRODYNAMICS OF MINIMAL BIOLOCOMOTION

PROJECT LEADERS

DSW Tam

RESEARCH THEME

Complex dynamics of fluids

PARTICIPANTS

Greta Quaranta (PhD Student)

COOPERATIONS

Dr. M.E. Aubin

Kavli Institute Delft

FUNDED

University	100 %
FOM	-
STW	-
NWO Other	-
Industry	-
TNO	-
GTI	-
EU	-
Scholarships	-

START OF THE PROJECT

2013

INFORMATION

D TAM

015 278 2991

D.S.W.Tam@tudelft.nl

PROJECT AIM

Unraveling, through experimental study, the minimal physical mechanisms necessary to achieve spontaneous beating and synchronization of cilia. This is obtained by dynamically interacting with flagellated micro-organisms (algae *C. Reinhardtii*) in real time, by generating an external mechanical forcing in the relevant force range and at the relevant length and time scales.

These experiments will answer the long standing question of whether cilia can synchronize via hydrodynamic interactions only.

PROGRESS

The project investigation has started in May 2013. The experimental setup is now fully working and data has been taken to evidence synchronization of eukaryotic flagella with external flows. Significant results have been collected confirming the hypothesis that synchronization of the organism with an external oscillator can be induced by hydrodynamics interaction only. We quantified the coupling strength between hydrodynamic forces and flagellar beating and found that the coupling is weak. This strongly suggests that flagellar synchronization is not primarily due to hydrodynamic forces. The importance of direct mechanical interaction through the cell cortex is now investigated.

DISSERTATIONS

-

SCIENTIFIC PUBLICATIONS

1. Quaranta, Greta, Marie-Eve Aubin-Tam, and Daniel Tam. "Hydrodynamics Versus Intracellular Coupling in the Synchronization of Eukaryotic Flagella." *Physical review letters* 115.23 (2015): 238101.

UPSCALING EXPLOSION SEVERITY PARAMETERS FROM LABORATORY TO INDUSTRIAL SCALE

PROJECT AIM

Despite tremendous research efforts in the last 30 years, dust explosions continue to pose a serious threat to the process industries. The aim of this project is to investigate the effect of scale, turbulence, and ignition energy on the explosion severity of dust explosions using different types of fuels. Explosion tests are carried out in a 20 L sphere and in a 1 m³ vessel.

PROGRESS

Experimental results obtained so far have underlined the weaknesses of the experimental procedures used to determine dust deflagration severity parameters (K_{St}, P_{max}), as well as the limitations of the cubic law used to scale dust deflagration severity. A better understanding of the mode of combustion of the different dusts (organics, chemicals, metals) is essential to explain the discrepancies observed experimentally. Next phases include completion of MIE/MAIT tests with metal dusts, completion of tests with different dusts (other than metals) using lower ignition strengths, investigation of dust dispersion in 20 L sphere and/or 1 m³ vessels by recording the dust dispersion process using high-speed video, use of dust burners in order to see the potential benefits vs. closed vessels. Publications are in preparation about metal dusts deflagration hazards (review), ignition induced hybrids, scaling of metal dust explosion severity.

DISSERTATIONS

-

SCIENTIFIC PUBLICATIONS

-

PROJECTLEADERS

DJEM Roekaerts

RESEARCHTHEME

Complex dynamics of fluids

PARTICIPANTS

Jérôme Taveau

COOPERATIONS

S.M. Lemkowitz (TU Delft ChemE)

S. Hochgreb, Cambridge University

FUNDED

Fike Corporation

University -

FOM -

STW -

NWO Other -

Industry 100 %

TNO -

GTI -

EU -

Scholarships -

START OF THE PROJECT

2014

INFORMATION

J Taveau

(+1) 816.655.4769

jerome.taveau@fike.com

AIR LEAKAGE CONTROL OF AIR CAVITY VESSELS FOR MARITIME TRANSPORT THROUGH HYDROPHOBIC COATINGS

PROJECT LEADERS

WP Breugem, TJC van Terwisga,
J. Westerweel

RESEARCH THEME

Complex dynamics of fluids

PARTICIPANTS

FT Charruault, WP Breugem,
TJC van Terwisga, J. Westerweel

COOPERATIONS

AkzoNobel Marine & Protective
Coatings

FUNDED

STW (TKI Maritiem)	
University	-
FOM	-
STW	100 %
NWO Other	-
Industry	-
TNO	-
GTI	-
EU	-
Scholarships	-

START OF THE PROJECT

2014

INFORMATION

FT Charruault
015 278 4766
f.t.charruault@tudelft.nl

PROJECT AIM

The frictional drag of a ship can contribute up to 70% to the total ship drag. This contribution can be strongly reduced by generating continuous air layers or so-called air cavities along the bottom surface of the ship. However, the efficiency of an air cavity depends heavily on the power needed to compensate for air leakage to the surroundings. In a previous PhD project two different mechanisms were identified to explain air cavity leakage: re-entrant jet entrainment and wave pinch-off entrainment. Our hypothesis is that a hydrophobic hull coating will strongly reduce the latter. We will perform both experiments and numerical simulations to test this hypothesis.

PROGRESS

Research has focused on experimental methods for time-resolved measurements of the interface topology of the tail of an air cavity. First coated panels have been delivered by AkzoNobel. First measurements have been performed in the TU Delft cavitation tunnel.

DISSERTATIONS

-

SCIENTIFIC PUBLICATIONS

-

EXPERIMENTAL STUDY OF TURBULENT COMBUSTION IN A SINGLE BURNER FURNACE

PROJECT AIM

The objective of the project is to get better fundamental understanding of flameless combustion. Specifically, the project aims to determine the effects of fuel composition, operational conditions and nozzle geometry on the flameless combustion process in a single-burner furnace. From visualization of the ignition and combustion characteristics in the furnace and analysis of the flue gas composition, it will be determined under which conditions the flameless combustion regime can be established in the single-burner furnace. A selected set of flames will then be studied in greater detail by measuring the velocity fields with PIV/LDA, the temperature with CARS and OH concentration with PLIF.

PROGRESS

A test furnace has been built, and all the safety control units have been tested, e.g. laser safety device, burner control box and gas detectors. All components for the final furnace with full optical access for laser diagnostics are ready and it is currently under construction. Preliminary modelling of the furnace has been performed with the eddy-dissipation-concept (EDC) model in Ansys Fluent. The results turn out to be very different from those of basic steady flamelet and FGM models, and much more computationally demanding. A decisive improvement in model accuracy is expected from the use of advanced forms the Flamelet Generated Manifolds (FGM) method. An extended FGM method with a 6-dimensional lookup table has been implemented in OpenFoam-2.3.1. This model includes a transport equation for dilution variable and an enthalpy transport equation in combination with a radiative heat transfer model. Now the model is being tested.

DISSERTATIONS

-

SCIENTIFIC PUBLICATIONS

1. X. Huang, Dirk Roekaerts. A preliminary simulation of flameless combustion in a single-burner furnace. In : Book of Abstracts, Combura Symposium, October 7-8, 2015, Soesterberg, Utrecht, The Netherlands.

PROJECT LEADERS

MJ Tummens, DJEM Roekaerts

RESEARCH THEME

Complex dynamics of fluids

PARTICIPANTS

Xu Huang

COOPERATIONS

WS GmbH

FUNDED

China Scholarship Council

University -

FOM -

STW -

NWO Other -

Industry -

TNO -

GTI -

EU -

Scholarships 100 %

START OF THE PROJECT

2013

INFORMATION

X Huang

015 278 6745

x.huang-2@tudelft.nl

THE INFLUENCE OF THE PROPERTIES OF ANTIFOULING COATINGS ON THE SKIN FRICTION AND TURBULENT BOUNDARY LAYER ALONG A SHIP

PROJECT LEADERS

WP Breugem, J Westerweel

RESEARCH THEME

Complex dynamics of fluids

PARTICIPANTS

HOG Benschop, WP Breugem,
J Westerweel

COOPERATIONS

We are part of a consortium consisting of 19 university groups, technology institutes and companies spread over Europe.

FUNDED

EU/FP7/OCEAN.2013.3 program

University	-
FOM	-
STW	-
NWO Other	-
Industry	-
TNO	-
GTI	-
EU	100 %
Scholarships	-

START OF THE PROJECT

2014

INFORMATION

H Benschop

015 278 6597

h.o.g.benschop@tudelft.nl

PROJECT AIM

This project is part of the European FP7 SEAFRONT program with the aim to develop environmentally benign antifouling coatings for ships. The specific goal of this PhD project is to develop fundamental understanding of the influence of the antifouling coating properties on the skin friction and the turbulent boundary layer along a ship. To this purpose Direct Numerical Simulations will be used to study the influence of the surface texture of a coating on the structure and dynamics of turbulence. In a later stage detailed experiments will be performed in our water tunnel on the turbulent boundary layer over various antifouling coatings developed within this program.

PROGRESS

Recent experimental results suggested a possible drag reduction of 20% for a herringbone riblet texture in a turbulent pipe flow, which is roughly twice the maximum drag reduction reported for the conventional parallel riblet texture. We have performed Direct Numerical Simulations (DNSs) of turbulent flow in a plane channel with textured walls. Experimental results of the parallel riblet texture have been reproduced numerically. However, a drag reducing effect of herringbone riblets has not been confirmed. Instead, a significant drag increase has been found, which is ascribed to the secondary flow that is generated by the converging/diverging riblets. It is therefore suggested that the herringbone riblets do not outperform the conventional parallel riblets. They seem more suitable for drag reduction by flow-separation delay.

DISSERTATIONS

-

SCIENTIFIC PUBLICATIONS

1. H.O.G. Benschop, J. Westerweel and W.-P. Breugem – Direct Numerical Simulations of Drag Reduction in Turbulent Channel Flow over Bio-inspired Herringbone Riblet Texture. 15th European Turbulence Conference 2015 (ETC15)

CHARACTERIZATION OF CAVITATION DURING THE CLOSING OF MECHANICAL (HEART) VALVES

PROJECT AIM

To characterize cavitation near closing (heart) valve using particle image velocimetry, high speed imaging, X-Rays and long-distance microscopy. These experiments will be performed in an existing pulsatile flow loop, which allows testing of both idealized and actual artificial heart valve under various conditions. To study the role of non-Newtonian behavior on the initiation and progression of cavitation; in particular we investigate blood-mimicking fluids.

PROGRESS

Literature review of research done on cavitation in mechanical (heart) valves. Design and order of Venturi to see the occurrence of cavitation under various conditions and parameters. 1st meeting of CaFE project on 10th of December 2015 in Lausanne, Switzerland.

DISSERTATIONS

-

SCIENTIFIC PUBLICATIONS

-

PROJECT LEADERS

C Poelma

RESEARCH THEME

Complex dynamics of fluids

PARTICIPANTS

Saad Jahangir

COOPERATIONS

City University London

Argonne National Laboratory

FUNDED

EU (Marie Skłodowska-Curie Actions) TU Delft

University 25%

FOM -

STW -

NWO Other -

Industry -

TNO -

GTI -

EU 75 %

Scholarships -

START OF THE PROJECT

2015

INFORMATION

S Jahangir

06 53878546

S.Jahangir@tudelft.nl

<http://delftpe.nl/node/933>

DYNAMICS OF VORTEX CAVITATION

PROJECT LEADERS

TJC van Terwisga, J Westerweel,
R Delfos

RESEARCH THEME

Complex dynamics of fluids

PARTICIPANTS

Ir. P.C. Pennings

COOPERATIONS

Part of the International Institute
for Cavitation Research (IICR),
cooperation with the Dynamics of
Vortex Cavitation on Ship and Pump
Impellers (DYNVOR) and the STW
Ship Drag Reduction projects

FUNDED

Entirely funded by the Lloyd's
Register Educational Trust
University -
FOM -
STW -
NWO Other -
Industry 100 %
TNO -
GTI -
EU -
Scholarships -

START OF THE PROJECT

2011

INFORMATION

PC Pennings
015 278 8351
p.c.pennings@tudelft.nl
pe.tudelft.nl

PROJECT AIM

Cavitating vortices trailing from a ship propeller are a source of inboard noise and vibration. When these vortices flow past rudders they could induce severe erosion. Ideally these harmful results should be prevented in the design stage. To be able to quantify sound emission, more understanding is needed of the dynamics of cavitating vortices. Therefore the aim of this project is to study the dynamics and sound emission of a cavitating vortex.

PROGRESS

Tip vortices are flow structures with concentrated vorticity which can persist far downstream of a propeller. A simplified case of a cavitating vortex trailing the tip of a stationary blade at incidence is studied. High speed video recordings combined with force and acoustic measurements have been used to better understand the dynamics that consist of waves on the interface between liquid and water vapour. Comparison to an analytic model of tip vortex cavity core vibrations has provided insight in the presence of different wave modes and their transport. This was quantitatively supported by Stereo Particle Image Velocimetry measurements for the same conditions.

DISSERTATIONS

-

SCIENTIFIC PUBLICATIONS

1. P.C. Pennings, J. Westerweel, T.J.C. van Terwisga, Cavitation tunnel analysis of radiated sound from the resonance of a propeller tip vortex cavity, *International Journal of Multiphase Flow* (under review) (2016).
2. P.C. Pennings, J. Westerweel, T.J.C. van Terwisga, Flow field measurement around vortex cavitation, *Experiments in Fluids* 56 (2015).
3. R. Arndt, P. Pennings, J. Bosschers, T. van Terwisga, The singing vortex, *Interface Focus* 5, (2015).
4. P.C. Pennings, J. Bosschers, J. Westerweel, T.J.C. van Terwisga, Dynamics of isolated vortex cavitation, *Journal of Fluid Mechanics* 778, 288–313 (2015).

DETAILED FLOW STRUCTURE ANALYSIS OF THE DIFFERENT TURBULENT AND TRANSITIONAL FLOW STATES IN CANONICAL FLOWS

PROJECT AIM

Research objective is to employ stereoscopic and tomographic particle image velocimetry (PIV) for detailed flow structure analysis of the different turbulent and transitional flow states in canonical flows, and explore the parameter space in search of different turbulent states and their characterization.

PROGRESS

Some experiments were already conducted in the Taylor-Couette system, and the results were presented in the last ETC conference. The results will be also published in a journal paper. In addition, preliminary measurements have been conducted on the pipe setup, and currently, the pipe setup is being prepared for the stereoscopic PIV measurements.

DISSERTATIONS

-

SCIENTIFIC PUBLICATIONS

-

PROJECTLEADERS

J Westerweel

RESEARCHTHEME

Complex dynamics of fluids

PARTICIPANTS

Melika Gul

Dr. ir. Gerrit Elsinga

Prof. dr. ir. Jerry Westerweel.

COOPERATIONS

-

FUNDED

University	-
FOM	100 %
STW	-
NWO Other	-
Industry	-
TNO	-
GTI	-
EU	-
Scholarships	-

START OF THE PROJECT

2014

INFORMATION

M Gul

06 44084160

M.Gul@tudelft.nl

HEAVY FUEL-OIL COMBUSTION IN A HITAC BOILER

PROJECT LEADERS

MJ Tummers, DJEM Roekaerts

RESEARCH THEME

Complex dynamics of fluids

PARTICIPANTS

H.R.C. Rodrigues

COOPERATIONS

TH van der Meer (U Twente)

S Zhu (U Twente)

FUNDED

Technology Foundation STW
(CCC program), Stork Thermeq,
Shell

University	-
FOM	-
STW	80 %
NWO Other	-
Industry	20 %
TNO	-
GTI	-
EU	-
Scholarships	-

START OF THE PROJECT

2010

INFORMATION

MJ Tummers
015 278 2477
m.j.tummers@tudelft.nl
www.cleancombustionconcepts.nl

PROJECT AIM

This project concerns the extension of the application of High Temperature Air Combustion (HiTAC) to heavy-oil combustion processes in a boiler and is a joint project of University Twente and Delft University of Technology. To generate the knowledge needed to be able to develop and design such a boiler, experimental and computational investigations will be made of turbulent spray flames under HiTAC conditions. At TU Delft, an experimental study of spray flames of light fuel oil burning in a co-flow of hot air diluted with combustion products will provide detailed knowledge of the relations between atomization process, ignition, entrainment and burnout.

PROGRESS

The PhD thesis was defended on January 22, 2015. Flames with several combinations of spray and coflow conditions have been studied in detail, namely 1) ethanol reacting sprays in air and hot-diluted coflow, 2) ethanol reacting sprays in different hot-diluted coflow conditions, and 3) acetone and ethanol sprays in an identical hot-diluted coflow. Combustion in hot-diluted coflow conditions in general leads to absence of high peak temperatures. The degree in which peak temperatures are avoided depends on the interaction between coflow conditions and the characteristics of the atomization process. The experimental datasets offer new opportunities for model validation. Its value comes from the combination of several features such as: challenging complexity, degree of completeness of the dataset for each single case and availability of several cases with different flame structure and liquid fuels.

DISSERTATIONS

1. H.R. Correia Rodrigues, Spray combustion in moderate and intense low-oxygen conditions - An experimental study -, Delft University of Technology, 2015

SCIENTIFIC PUBLICATIONS

1. Hugo Correia Rodrigues, Mark J. Tummers, Eric H. van Veen, Dirk J.E.M. Roekaerts Spray flame structure in conventional and hot-diluted combustion regime, *Combustion and Flame*, 162 (2015) 759-773.
<http://dx.doi.org/10.1016/j.combustflame.2014.07.033>
2. H. Correia Rodrigues, M.J. Tummers, E.H. van Veen, D.J.E.M. Roekaerts, Effects of coflow temperature and composition on ethanol spray flames in hot-diluted coflow, *Int. J. Heat Fluid Flow*, 51 (2015) 309-323
<http://dx.doi.org/10.1016/j.ijheatfluidflow.2014.10.006>
3. S. Zhu, D.J.E.M. Roekaerts, A. Pozarlik, Th.H. van der Meer, Eulerian-Lagrangian RANS model simulations of the NIST turbulent methanol spray flames, *Combustion Science and Technology*, 187 (7):1110-1138, 2015,
<http://dx.doi.org/10.1080/00102202.2015.1019616>

DISPERSION IN THE TURBULENT URBAN ENVIRONMENT (DISTURBE)

PROJECT AIM

The current research proposal aims at finding the mechanisms that are responsible for the turbulent dispersion of air pollution near major urban roadways. The project focuses on complex geometries at the scale of several buildings and roadways (10-1000m), which are typical of cities. Finally, attention is given to the prediction of peak pollution concentrations.

PROGRESS

Large-eddy simulations (LES) are used to investigate the effect of stable stratification on rural-to-urban roughness transitions. Smooth wall turbulent boundary layers are subjected to a generic urban roughness consisting of cubes in an in-line arrangement. Investigation of the turbulence kinetic energy budget shows that the buoyancy effects are reduced in the internal boundary layer. In addition, the stable stratification affects pollutant dispersion appreciably. Finally, it is concluded that in the first seven streets the vertical advective pollutant flux is significant in contrast to the fully-developed case.

DISSERTATIONS

-

SCIENTIFIC PUBLICATIONS

1. J.M. Tomas, H.E. Eisma, M.J.B.M. Pourquie, G.E. Elsinga, H.J.J. Jonker, J. Westerweel, 2015. Pollutant Dispersion in the Urban Boundary Layer. In: Fröhlich, J., Kuerten, H., Geurts, B.J., Armenio, V. (Eds.), Direct and Large-Eddy Simulation IX, ERCOFTAC Series, Vol. 20, Springer, pp. 435-442.
2. J.M. Tomas, M.J.B.M. Pourquie, H.J.J. Jonker, The influence of an obstacle on flow and pollutant dispersion in neutral and stable boundary layers, Atmospheric Environment 113, 236-246.
3. J.M. Tomas, M.J.B.M. Pourquie, H.E. Eisma, H.J.J. Jonker, The effect of stable stratification on boundary layer development and pollutant dispersion behind an obstacle, EUROMECH Colloquium 567: Turbulent mixing in stratified flows, 22-25 March 2015, DAMTP, Centre for Mathematical Sciences, Cambridge, UK.
4. J.M. Tomas, M.J.B.M. Pourquie, H.J.J. Jonker, Pollutant dispersion in neutral and stable boundary layers entering an urban environment, 9th International Symposium on Turbulence and Shear Flow Phenomena (TSFP-9), June 30 - July 3, 2015, Melbourne, Australia.

PROJECT LEADERS

J Westerweel, GE Elsinga,
M Pourquie, HJJ Jonker, JCR Hunt

RESEARCH THEME

Complex dynamics of fluids

PARTICIPANTS

Jerke Eisma
Jasper Tomas
Manu Goudar Vishwanathappa

COOPERATIONS

Names of national and international
cooperations (when relevant).

FUNDED

KEMA, TNO, FlowMotion, RWS
University -
FOM -
STW -
NWO Other -
Industry -
TNO -
GTI -
EU -
Scholarships -

START OF THE PROJECT

2012

INFORMATION

GE Elsinga
015 278 8179
G.E.Elsinga@tudelft.nl
<http://delftpe.nl/Chairs/FM>

MODELING AND SIMULATION OF SEDIMENT TRANSPORT

PROJECT LEADERS

LM Portela, C Schaerer,
N Mangiavachi

RESEARCH THEME

Mathematical and computational
methods for fluid flow analysis

PARTICIPANTS

H Shin

COOPERATIONS

State University of Rio de Janeiro
National University of Asuncion

FUNDED

University -
FOM -
STW -
NWO Other -
Industry -
TNO -
GTI -
EU -
Scholarships 100 %

START OF THE PROJECT

2015

INFORMATION

LM Portela
06 20046078
l.portela@tudelft.nl

PROJECT AIM

Use sophisticated numerical simulation techniques, like DNS and LES,
to improve the modelling and simulation of sediment transport using simpler
engineering simulation tools (like two-fluid models and simple quasi-1D models)

PROGRESS

Point-particle DNS simulations were performed in order to determine
several parameters used in two-fluid simulations of sediment transport (in the
figure is shown the particle Schmidt number)

DISSERTATIONS

-

SCIENTIFIC PUBLICATIONS

-

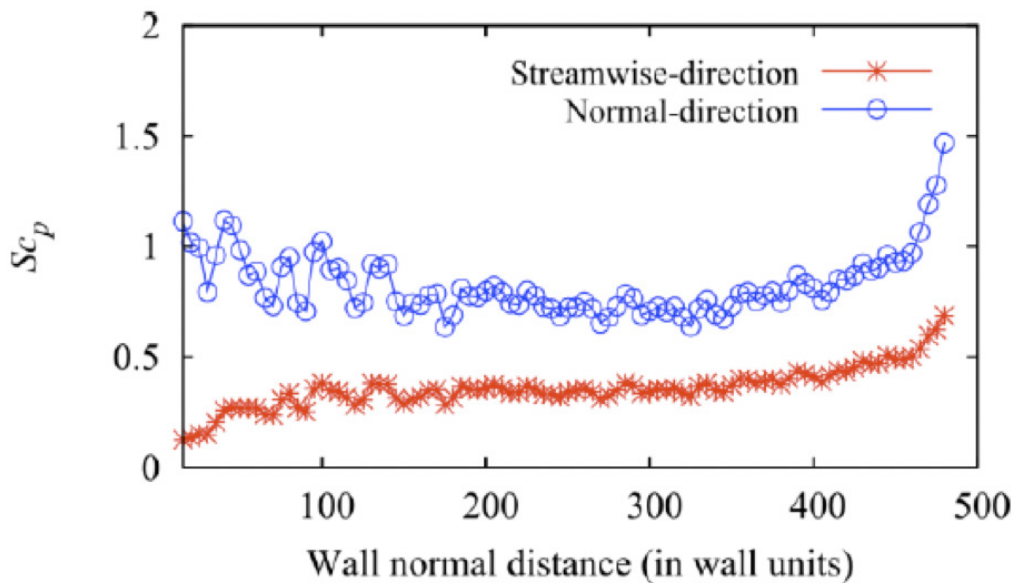

TWO-PHASE FLOW MEASUREMENT USING ULTRASOUND IMAGE VELOCIMETRY

PROJECT AIM

The aim of the project is to investigate and advance the application of ultrasound image velocimetry (UIV) for non-intrusive measurement of a wide range of flow.

PROGRESS

We conducted three separate projects using UIV. First, we measured the pipe flow of a complex yielding fluid, a model drilling mud and characterized its rheology based on the measured velocity profile. We compared the results against the reference measurement technique, Couette rheometry. We presented our work at the PIV2015 conference in September 2015 and have been invited to submit a full paper to the journal of Measurement Science and Technology. The second project involved the investigation of complex flow behavior such as shear banding at different shear rate regimes. Using Heinz ketchup as a reference thixotropic fluid, we coupled UIV with Taylor-Couette rheometer to simultaneously measure the flow velocity profiles and rheology. The manuscript describing the results of this study is currently under preparation and will be submitted for publication in either the Physical Review Letters or Journal of Rheology. The third project involved instantaneous velocity field measurement in densely-laden two-phase flows using UIV. We validated UIV against DNS to obtain statistics in turbulent two-phase flows and conducted a systematic study on the effects of particle loads on turbulent flows. The findings of this study will be presented at ICMF 2016 in Italy in May 2016. A full paper will be submitted for publication in the journal of Experiments of Fluids.

DISSERTATIONS

-

SCIENTIFIC PUBLICATIONS

1. Gurung A, Drost S, Norder B, Westerweel J and Poelma C (2015). Ultrasound Image Velocimetry for real-time rheological measurements. 11th International Symposium on Particle Image Velocimetry, At Santa Barbara (CA, USA), September 2015.

PROJECT LEADERS

C Poelma, J Westerweel

RESEARCH THEME

Complex dynamics of fluids

PARTICIPANTS

Shell

COOPERATIONS

-

FUNDED

University -
FOM -
STW -
NWO Other -
Industry -
TNO -
GTI -
EU -
Scholarships -

START OF THE PROJECT

-

INFORMATION

A Gurung
06 18797082
A.Gurung@tudelft.nl
<http://delftpe.nl/node/857>

PROJECT LEADERS

DJEM Roekaerts

RESEARCH THEME

Mathematical and computational methods for fluid flow analysis

PARTICIPANTS

Likun Ma

COOPERATIONS

B. Naud, CIEMAT, Madrid

FUNDED

China Scholarship Council

University -

FOM -

STW -

NWO Other -

Industry -

TNO -

GTI -

EU -

Scholarships 100 %

START OF THE PROJECT

2012

INFORMATION

L Ma

015 278 6745

l.ma@tudelft.nl

PROJECT AIM

Spray flames are widely used in industrial furnaces, power generation system, etc. and there is a need for computational models to predict their properties. The objective of this project is to develop and validate accurate and efficient modeling approaches for turbulent spray combustion. The models should describe the main physical and chemical processes, notably phase change, turbulence, chemical reaction and radiation and their mutual interactions. Models will be developed for dilute spray combustion and for the coupling between dense spray and dilute spray regions.

PROGRESS

To achieve a better understanding on the dynamic characteristics of the Delft Spray-in-Hot-Coflow (DSHC) flames, and towards a more accurate description of the two-phase flow system Large Eddy Simulations have been carried out. In order to do so, the Flamelet Generated Manifolds (FGM) model has been implemented in OpenFoam. Two major model developments were completed — the Condition Droplet Injection Model (CDIM) and the non-adiabatic FGM method. The CDIM was proposed to take into account the influence of flash-boiling atomization of the DSHC flames. For a base case, the comparison of CIDM with a conventional droplet injection model showed superior performance of the CDIM in modeling the DSHC flames. Furthermore, with the addition of enthalpy deficit as an extra dimension of the FGM table, the prediction of the gas phase temperature was significantly improved. Next the LES/FGM method was applied to a wide range of experimentally studied cases, including hot and cold coflow cases, to test the range of applicability of models, and to some virtual (i.e. not yet studied experimentally) cases in order to gain deeper insight on the involved phenomena.

DISSERTATIONS

-

SCIENTIFIC PUBLICATIONS

1. L. Ma, D. Roekaerts, Modeling of spray jet flame under MILD condition with non-adiabatic FGM and a new conditional droplet injection model, *Combustion and Flame*, Accepted 26 december 2015
2. L. Ma, B. Naud, D. Roekaerts, Transported PDF modeling of ethanol spray in hot-diluted coflow flame, *Flow, Turbulence and Combustion*, 2015, DOI: 10.1007/s10494-015-9623-3
3. L. Ma, D. Roekaerts, Numerical study of turbulent spray combustion using OpenFOAM, *OpenFoam Users Conference*, October 2015, Stuttgart, Germany, 18 pages.
4. L. Ma, B. Naud, D. Roekaerts, Lagrangian-Lagrangian Modeling of ethanol spray in hot-diluted coflow flame, In: A. D'Anna, F. Beretta, M. Mansour, N. Selçuk (Eds.), *Proceedings of the 9th Mediterranean Combustion Symposium*, Rhodes, Greece, June 7-11, Paper NCC-2, 2015, 12 pages.
5. S.H. Jamali, L. Ma, D. Roekaerts, Computational Study of Ethanol Flameless Combustion Using FGM and Steady Flamelet, In: A. D'Anna, F. Beretta, M. Mansour, N. Selçuk (Eds.), *Proceedings of the 9th Mediterranean Combustion Symposium*, Rhodes, Greece, June 7-11, Paper NCC-3, 2015, 12 pages.

IMPACT OF BOILING LIQUID ON FLUID-VAPOUR-WALL INTERACTION IN LNG TRANSFER SYSTEMS

PROJECT AIM

To investigate and understand the significant flow-mechanisms occurring in a cryogenic flow through a corrugated hose. The large increase in pressure-drop in such flows is not understood yet, and we aim to be able to predict the pressure-drop and determine why. This might help optimize the transport-hose geometry.

PROGRESS

Measurements have been finalized. Postprocessing is being executed and the final thesis is in progress.

DISSERTATIONS

-

SCIENTIFIC PUBLICATIONS

-

PROJECTLEADERS

J Westerweel

RESEARCHTHEME

Complex dynamics of fluids

PARTICIPANTS

-

COOPERATIONS

-

FUNDED

University	-
FOM	-
STW	-
NWO Other	-
Industry	-
TNO	-
GTI	-
EU	-
Scholarships	-

START OF THE PROJECT

2011

INFORMATION

M Schenker

m.c.schenker@tudelft.nl

MODELING THE INFLUENCE OF FLOW ON ASPHALTENE AGGLOMERATION AND DEPOSITION

PROJECT LEADERS

RAWM Henkes, LM Portela,
A Twerda

RESEARCH THEME

Mathematical and computational methods for fluid flow analysis

PARTICIPANTS

K.C.J. Schutte (PhD student)

COOPERATIONS

TNO, ENI (ISAPP2)

FUNDED

ENI	
University	25 %
FOM	-
STW	-
NWO Other	-
Industry	75 %
TNO	-
GTI	-
EU	-
Scholarships	-

START OF THE PROJECT

2011

INFORMATION

RAWM Henkes
06 52096201
R.A.W.M.Henkes@tudelft.nl

PROJECT AIM

Asphaltenes are heavy organic deposits that can be formed when the oil transport from subsurface reservoirs undergoes a sharp drop in pressure. Models are used for the prediction of asphaltene deposition and give important input to the design of deposition prevention and remediation methods. Models used so far in the oil and gas industry are highly empirical. The aim of the present project is to better understand the fundamentals of the influence of flow on the agglomeration and deposition process of asphaltenes. This will result into both new detailed flow models, as well as into improved models that can be used in the industry.

PROGRESS

We have developed and implemented an Eulerian-Lagrangian model for the transport, formation, break-up, deposition and re-entrainment of asphaltene agglomerates, as it occurs in the turbulent flows that are commonplace in wellbores and production pipelines. The complex structure of the agglomerates is explicitly taken into account; in this respect this model is the first of its kind. In principle, the model can also be used to study agglomeration and deposition phenomena in other systems, such as in atmospheric pollution transport or inside human veins or arteries. Simulations for agglomeration and break-up in the absence of deposition and reentrainment were carried out to investigate how the properties of the agglomerates change with the Reynolds number of the turbulent flow, the strength of the bonds inside the agglomerates, and the mechanism by which the agglomerates are broken. This was done for both channel- and pipe flows. The results show that the properties of the agglomerates are rather insensitive to the mechanisms that cause their break-up, as well as to the Reynolds number, provided the flow is turbulent. Furthermore, simulations were performed in which deposition and re-entrainment are included in the Eulerian-Lagrangian model. If the adhesion strength between the dispersed phase and the walls is large, stable deposit layers can be formed. In this regime, the strength of the internal bonds of the agglomerates becomes the limiting factor for the thickness of the deposit layer. The wall-normal velocity of the agglomerates during deposition, which is also used as a closure for engineering models, is underpredicted by empirical relations proposed in the literature.

DISSERTATIONS

SCIENTIFIC PUBLICATIONS

1. Schutte, K.C.J., Portela, L.M., Twerda, A., Henkes, R.A.W.M. Hydrodynamic perspective on asphaltene agglomeration and deposition. *Energy & Fuels* 29, pp 2754–2767, 2015. DOI: 10.1021/ef501931h.

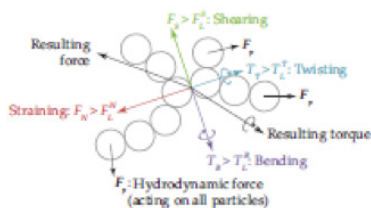

Decomposition of internal stresses induced in the inter-particle bonds by hydrodynamic forces.

PERFORMANCE OF FOAMERS FOR DELIQUIFICATION OF GAS WELLS

PROJECT AIM

This project is a combined experimental/modeling study on the performance of foamers for deliquification of gas wells as used in the gas and oil industry. The reduction of the reservoir pressure for maturing fields will cause that gas wells will start to accumulate liquid (water, condensate). The use of proper foamer chemicals will mix the liquid and gas into a foam, which decreases the hydrostatic head in the well and re-establishes the flow. The study includes flow experiments using a facility with pipe lengths of about 15 m and three diameters: 34, 50 and 80 mm.

PROGRESS

The experiments were concluded and A.T. van Nimwegen wrote his Ph.D. thesis and had his defense in June 2015. A. T. van Nimwegen continued working in the project as a postdoc. The ideas for modeling resulted in a simple 1D model, which was successfully tested against the experimental data and was implemented in the computer codes used by Shell/NAM.

DISSERTATIONS

1. A. T. van Nimwegen, The effect of Surfactants on Gas-Liquid Pipe Flows. TU Delft. Promotor: R.A.W.M. Henkes. Co-promotor: L.M. Portela.

SCIENTIFIC PUBLICATIONS

1. A. T. van Nimwegen, L. M. Portela, and R. A.W. M. Henkes. The effect of surfactants on air-water annular and churn flow in vertical pipes. Part 1: Morphology of the air-water interface. International Journal of Multiphase Flow, vol. 71, pp. 133-145 (2015).
2. A. T. van Nimwegen, L. M. Portela, and R. A.W. M. Henkes. The effect of surfactants on air-water annular and churn flow in vertical pipes. Part 2: Liquid holdup and pressure gradient dynamics. International Journal of Multiphase Flow, vol. 71, pp.146-158 (2015).
3. D. Kawale, A. T. van Nimwegen, L. M. Portela, M. A. van Dijk and R.A.W.M. Henkes. The relation between the dynamic surface tension and the foaming behavior in a sparger setup. Colloids and Surfaces A – Physicochemical and Engineering Aspects, vol. 481, pp. 328-336 (2015).

PROJECT LEADERS

R.A.W.M. Henkes
L.M. Portela

RESEARCH THEME

Complex structures of fluids

PARTICIPANTS

A.T. van Nimwegen
(PhD student and postdoc)

COOPERATIONS

NAM/Shell

FUNDED

NAM	
University	25 %
FOM	-
STW	-
NWO Other	-
Industry	75 %
TNO	-
GTI	-
EU	-
Scholarships	-

START OF THE PROJECT

2010

INFORMATION

RAWM Henkes
06 52096201
R.A.W.M.Henkes@tudelft.nl

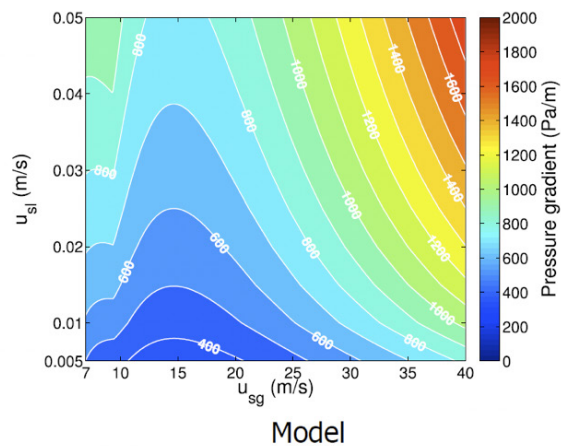
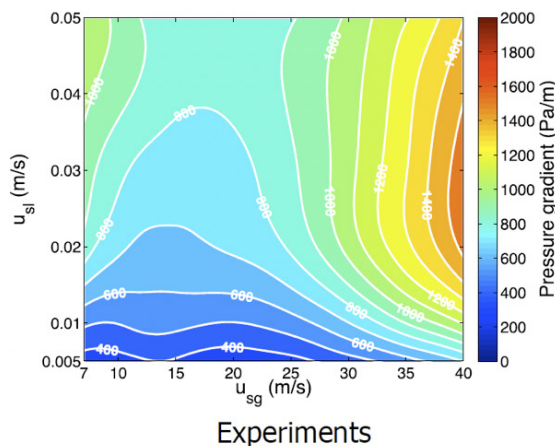



Prof.dr.ir. RHM Huijsmans



Prof.dr.ir. TJC van Terwisga

SEAKEEPING AND MANOEUVRING - PROF. RHM HUIJSMANS

Research of the Chair of Ship motions and manoeuvring is at present focused on the following areas: 1. Non-linear behaviour of fast craft in waves; 2. Extreme wave events in relation to stationary floating structures; 3. Very Large Floating Structures at sea; 4. Prediction of manoeuvring forces based on CFD methods.

High speed ships traveling in waves experience large amplitude motions which can lead to strong non-linear effects in the loads on the hull girder. These non-linear effects are due partly to the large changes in the wetted part of the hull in waves and partly due to non-linear pressure effects. Extreme wave events (breaking waves etc.) can lead to high impact loads on stationary floating structures, e.g. bow loads on Floating Production and Storage vessels for the oil industry. Hydrodynamic analysis of such behaviour is now moving towards application of CFD methods to determine the local flow at the bow. In order to simulate open sea conditions, the CFD region will be connected to an outer region which will be described by potential flow methods. This will allow waves to enter the region local to the bow and reflected waves to travel away from the bow thus minimizing reflections from the CFD boundary. Very Large Floating Structures are being investigated world-wide for various applications such as airports and for floating cities. This research is aimed at developing a novel concept of a large floating structure based on the use of air cushions to support the structure and distribute the wave loads thus optimizing both motion behaviour and structural costs. Manoeuvring models for ships have traditionally been based on equations of motions using experimentally determined drag, mass and lift coefficients. This research aims to investigate the applicability of CFD methods in determining the hydrodynamic coefficients for existing mathematical models. Use is made of a RANS code developed by MARIN and modified to accommodate oblique flow.

PROPULSION AND RESISTANCE - PROF. T VAN TERWISGA (PART TIME)

Research at the Chair of propulsion and resistance is focussed on three areas: 1. Cavitating Flows; 2. Ship-Propeller-Engine system in Service Conditions; 3. Drag reduction through air lubrication.

Cavitation remains an important field of investigation in Marine Technology. Almost all propellers in operation show cavitation in some but mostly in all working conditions. Cavitation often is an important source of vibrations and sometimes even cavitation erosion. Cavitation on propellers should therefore be controlled as much as possible in both the design and during operations. As cavitation often appears to be extremely unsteady and unstable, this poses a continuing challenge to designers and research groups. The more so because an acceptable cavitation control and a high propulsive efficiency are often conflicting requirements. The Delft Cavitation Tunnel has proven to be a strategic tool for enhancing our understanding of the physics and engineering characteristics. There are currently two PhD projects addressing this issue: One on unsteady sheet cavitation (E.J. Foeth) and another on propeller radiated pressure fluctuations (E.v.Wijngaarden). Ship-Propeller-Engine system analysis and simulation is important to reduce e.g. radiated noise from the propeller and to reduce wear of the propulsion system during its operation. To this end, a close cooperation exists with the section of Marine Engineering. There is currently a PhD project concerned with the development of a model podded propeller for testing in operational conditions (G. Oosterhuis), and a recent PhD project on improved propulsion control for Naval Vessels (A.Vrijdag). Initiatives in the third area on Drag reduction through air lubrication are currently under way.

ACTIVE MOTION CONTROL OF FAST SHIPS

PROJECT AIM

The aim of the PhD project is to develop an advanced ride control system for fast ships in order to improve its sea keeping behavior. The motions of these ships can be controlled by use of active flaps or interceptors located at the stern of the vessel. This project focuses on the control of these mechanisms by a proactive system that uses wave information at some distance in front of the bow. A very fast onboard simulation routine will be used to find the optimal settings of the control devices to increase the operability of the vessel in a seaway.

PROGRESS

A series of model tests have been performed in the towing tank of the Delft University of Technology to demonstrate the feasibility and the performance of the proactive control system in a real-world environment. The speed of the towing carriage and the deflections of the interceptors were continuously controlled based on the outcome of the real-time response predictions. The measured results obtained during these experiment agree to a large extent to the numerical results that were previously produced in a computer simulation. The model, with the proactive control system, could attain a high average forward speed while the seakeeping behavior was significantly improve in comparison to the benchmark tests without control.

DISSERTATIONS

-

SCIENTIFIC PUBLICATIONS

-

PROJECTLEADERS

RHM Huijsmans, JA Keuning

RESEARCHTHEME

Mathematical and computational methods for fluid flow analysis

PARTICIPANTS

AAK Rijkens

COOPERATIONS

-

FUNDED

IOP Maritiem, TU Delft, Damen Shipyard Group, Ministry of Defense MARIN, Bureau Veritas, Lloyd's Register, Imtech Marine & Offshore, Quantum Controls

University 75 %

FOM -

STW -

NWO Other -

Industry 25 %

TNO -

GTI -

EU -

Scholarships -

START OF THE PROJECT

2011

INFORMATION

AAK Rijkens

015 278 6872

a.a.k.rijkens@tudelft.nl

www.3me.tudelft.nl/mtt

DREDGING ENGINEERING



Prof.dr.ir. C van Rhee

Large volumes of sediment are displaced nowadays using different types of dredging equipment. Especially the last decade, large land reclamation projects attained global attention. Examples of these enormous projects are the new airports in Hong Kong and Singapore, the large land reclamations for ports and industry in Singapore, the spectacular projects in Dubai like the palm Islands and “the World” and the Maasvlakte II currently under construction in the Netherlands.

All Dredging processes involve slurry flows and are dominated by erosion, transport and sedimentation under special hydraulic conditions like high volumetric sediment concentration and or high flow velocity.

The research topics within the section of Dredging Engineering are focused on the physical processes encountered during dredging (and mining):

- ◆ Excavation processes of saturated sediments (mechanical, hydraulic or a combination).
- ◆ Hydraulic transportation of sediment water mixtures.
- ◆ Mixing and separation process (like the sedimentation process in a hopper of a Trailing Suction Hopper Dredge)
- ◆ Erosion and settling of sediments.
- ◆ Wear of flow components due to hydraulic transport.

TOWARDS RESPONSIBLE EXTRACTION OF SUBMARINE MINERAL RESOURCES

PROJECT AIM

The aim of the project is to support the marine mining industry with scientific advice towards the responsible sub-sea discharge of mining residue (tailings). In order to develop this advice, a three-dimensional numerical model is developed to simulate turbulent particle laden density plumes in deep waters and their interactions with a sedimentary boundary.

PROGRESS

Validation of the open-source CFD software for various types of turbulent single-phase discharges, Free jet, jet in cross-flow and impinging jets, with a large eddy simulation model. Suspended solids can be modeled as passive tracers (weightless). A drift-flux model which also captures negative buoyancy, particle slip and slurry viscosity is yet to be validated.

DISSERTATIONS

-

SCIENTIFIC PUBLICATIONS

-

PROJECT LEADERS

C van Rhee

RESEARCH THEME

Mathematical and computational methods for fluid flow analysis

PARTICIPANTS

F van Grunsven, G Keetels,
C van Rhee

COOPERATIONS

NIOZ, WUR/Imares and TNO

FUNDED

Imares, TNO, Royal IHC, Royal
Boskalis, Allseas, Van Oord & STW
University -
FOM -
STW 64 %
NWO Other -
Industry 35 %
TNO 1 %
GTI -
EU -
Scholarships -

START OF THE PROJECT

2014

INFORMATION

F van Grunsven
015 278 3583
f.vangrunsven@tudelft.nl
staff.tudelft.nl/F.vangrunsven/

UNSTABLE BREACHING

PROJECT LEADERS

C van Rhee

RESEARCH THEME

Mathematical and computational methods for fluid flow analysis

PARTICIPANTS

D Weij

COOPERATIONS

Deltares

FUNDED

SSB, Rijkswaterstaat

University 10 %

FOM -

STW -

NWO Other -

Industry 70 %

TNO -

GTI 20 %

EU -

Scholarships -

START OF THE PROJECT

2013

INFORMATION

D Weij

015 278 5524

D.Weij@tudelft.nl

<http://www.3me.tudelft.nl/en/about-the-faculty/departments/maritime-and-transport-technology/research/offshore-and-dredging-engineering/dredging-engineering/phd-research/dave-weij/>

PROJECT AIM

Breaching is a gradual retreat of a sub-aqueous slope, which is steeper than the angle of repose near the top of the slope. While mainly investigated due to the application of this process in the breaching process, the breaching process can also be a cause for unwanted slope instability and failure. These failures are usually caused by unstable breaching, where the size of the retreating slope increases during the process. The aim of this project is to investigate the unstable breaching process using numerical methods. The main interest in this project is the 3D effects during the process, and the effect of large scale effects.

PROGRESS

We currently have a working model, which can simulate flows of water and sand-mixture, with the possibility of very high concentrations, where sand grains are in contact with each other and there is a yield stress. The model also includes the interaction between dilatancy and pore pressure. We are currently busy validating this model with experimental data from literature.

DISSERTATIONS

-

SCIENTIFIC PUBLICATIONS

-

REDUCTION OF HYDROABRASIVE WEAR IN THE DREDGING INDUSTRY

PROJECT AIM

Pipelines used for slurry transport in dredging applications have been observed to wear in some projects up to about 1 mm per month. On-board tubing may even wear faster. This project originates from a long-standing wish to accurately predict service life of components on dredging vessels and to prolong service life in an economic way. The scientific aim of the project is to quantify the wear rate from the actual physical wear processes, providing a scientific basis for the suggestion of methods to improve the service life of equipment for hydro transport systems in dredging.

PROGRESS

Experiments were performed to compare wear in saltwater and freshwater conditions. The data was processed and analysis was performed. For the material used (carbon steel), the salt water produces higher wear. The higher wear is probably due to synergism. The results are in agreement with the findings in Slurry pot experiments by S.S. Rajahram et al. (Wear 2009). Moreover, the slurry flow in a straight vertical pipe was simulated using Discrete particle simulation method and wear due to the particle impact was calculated.

DISSERTATIONS

-

SCIENTIFIC PUBLICATIONS

-

PROJECTLEADERS

C van Rhee

RESEARCHTHEME

Complex dynamics of fluids

PARTICIPANTS

EA Chemmalasseri (PhD-Student)

Dr. ir. Geert Keetels (Daily supervisor), Dr. ir. A. M. Talmon

COOPERATIONS

Boskalis, Van Oord, IHC Merwede
MTI

FUNDED

Materials Innovation Institute

University 30 %

FOM -

STW -

NWO Other 30 %

Industry 30 %

TNO -

GTI -

EU -

Scholarships -

START OF THE PROJECT

2012

INFORMATION

EA Chemmalasseri

015 278 7430

E.A.Chemmalasseri@tudelft.nl

VERTICAL HYDRAULIC TRANSPORT FOR DEEP SEA MINING – A STUDY INTO FLOW ASSURANCE

PROJECT LEADERS

C van Rhee, AM Talmon

RESEARCH THEME

Complex dynamics of fluids

PARTICIPANTS

JM van Wijk

COOPERATIONS

-

FUNDED

Royal IHC, IHC MTI

University -

FOM -

STW -

NWO Other -

Industry 100%

TNO -

GTI -

EU -

Scholarships -

START OF THE PROJECT

2011

INFORMATION

JM van Wijk

06 53567368

jm.vanwijk@mtiholland.com

PROJECT AIM

To assess flow assurance of the vertical hydraulic transport process, especially the risk of riser blockage is studied.

PROGRESS

The objectives of this research project are to validate the blockage hypothesis (merging of batches) and to develop a model that describes the vertical hydraulic transport of solids, both in space and time, in a riser with booster stations.

DISSERTATIONS

-

SCIENTIFIC PUBLICATIONS

1. J.M. van Wijk, P.M. Smit, Design and internal flow simulation of a vertical hydraulic transport system for mining manganese nodules, Seventeenth International Conference on Transportation and Sedimentation of Solid Particles, 22-25 September, Delft, The Netherlands (2015).
2. J.M. van Wijk, F. van Grunsven, A.M. Talmon, C. van Rhee, Simulation and experimental proof of plug formation and riser blockage during vertical hydraulic transport, *Ocean Engineering* 101, 58–66 (2015).
3. J.M. van Wijk, B.G. Blok, The influence of grain size on the performance of conductivity concentration meters, *Flow Measurement and Instrumentation* 45, 384–390 (2015).

MODELING OF A ROCK WATER MIXTURE IN A DREDGE CUTTER HEAD

PROJECT AIM

Current rock cutter heads spill up to 50% of the cut rock in most unfavourable conditions. Spillage can be defined as the amount of rock that is cut loose, but is not sucked up by the suction mouth. Spillage is caused by the cutting process and by the mixing process of cut rock with water in the cutter head. The goal of this research is to quantitatively describe the mixture processes of cut rock in a rotating dredge cutter head using a numerical model. With this knowledge an improved cutter head can be designed in the future or operational conditions can be changed to obtain more production.

PROGRESS

In 2015 I've set up of experiments to validate the motion of rock particles in a cutter. These experiments will be performed in 2016. A particles will be put into a rotating cylindrical drum. The trajectory of these particles will be captured using a high speed camera and afterwards the particle paths will be evaluated using a PTV technique. During the experiment the water velocities will be measured using a Accoustic Doppler Velocimeter. For the numerical part, I've created a new model of a cutter with axial suction. A LES and RANS approach were both tested including a sliding mesh method. Also the pressure boundary condition on a rotating blade was improved in the modeling package OpenFOAM.

DISSERTATIONS

-

SCIENTIFIC PUBLICATIONS

-

PROJECTLEADERS

C van Rhee

RESEARCHTHEME

Complex dynamics of fluids

PARTICIPANTS

GH Keetels, AM Talmon,
IK van Giffen

COOPERATIONS

Royal Boskalis Westminster,
van Oord

FUNDED

Stichting Speurwerk Baggertechniek
(SSB)

University	-
FOM	-
STW	-
NWO Other	-
Industry	100 %
TNO	-
GTI	-
EU	-
Scholarships	-

START OF THE PROJECT

2012

INFORMATION

B Nieuwboer
015 278 9296
B.J.Nieuwboer@tudelft.nl

NUMERICAL ANALYSIS



Prof.dr.ir. C Vuik

Prof.dr.ir. Oosterlee

The research program of the Numerical Analysis group of TUD belongs to the field of computational science and engineering. We concentrate on the development and application of computing methods to the applied sciences. The focus is on mathematical models relying heavily on partial differential equations, such as occur in fluid dynamics. But we also consider similar mathematical models arising in other fields, for instance materials science and reservoir engineering, usually in cooperation with domain experts. A specialty is problems involving partial differential equations with moving internal boundaries, such as occur in bubbly flows and in phase transition problems. To diminish computing time in large-scale applications, iterative methods for solving large systems of algebraic equations are developed further, using deflation, multi-block, preconditioning and multigrid techniques.

Finally, these methods are implemented on modern hardware, clusters of PC's, GPU's and FPGA's. In order to achieve good results also HPC research is done in our group.

MATHEMATICAL INVESTIGATION INTO SMOOTHNESS-INCREASING ACCURACY-CONSERVING METHODS FOR STREAMLINE VISUALIZATION

PROJECT AIM

The purpose of the proposed research is the mathematical and algorithmic development of smoothness-increasing accuracy-conserving filters with application to post-processing and visualizing discontinuous Galerkin simulation results.

PROGRESS

This past year focused on the theoretical and computational viability of the SIAC filter for geometry that includes nonuniform meshes and filtering for boundaries.

DISSERTATIONS

1. Smoothness-Increasing Accuracy-Conserving Filters for Discontinuous Galerkin Methods: Challenging the Assumptions of Symmetry and Uniformity. Author: Li, X. Promotor: Vuik, C.. Faculty: Electrical Engineering, Mathematics and Computer Science. Department: Applied mathematics. Date: 2015-07-09 ISBN: 978-94-6186-500-7

SCIENTIFIC PUBLICATIONS

1. J.K. Ryan and X. Li and R.M. Kirby and C. Vuik One-sided Position-Dependent Smoothness-Increasing Accuracy-Conserving (SIAC) Filtering Over Uniform and Non-uniform Meshes Journal of Scientific Computing, 64, pp. 773-817, 2015.

PROJECT LEADERS

JK Ryan

RESEARCH THEME

Mathematical and computational methods for fluid flow analysis

PARTICIPANTS

X Li

COOPERATIONS

University of Utah, Salt Lake City, UT

FUNDED

European Office of Aerospace Research and Development/U.S. Air Force Office of Research and Development

University 20 %

FOM -

STW -

NWO Other -

Industry -

TNO -

GTI -

EU 80 %

Scholarships -

START OF THE PROJECT

2009

INFORMATION

JK Ryan

015 278 8755

J.K.Ryan@tudelft.nl

<http://ta.twi.tudelft.nl/NW/users/ryan/>

PROJECT LEADERS

C Vuik, A Segal

RESEARCH THEME

Complex dynamics of fluids

PARTICIPANTSC Vuik, A Segal, JM Tang,
R Nabben**COOPERATIONS**TU Eindhoven, Sepra, TNO-Science
and Industry, TU Berlin**FUNDED**

TUD, TNO-TPD, BRICKS

University 25 %

FOM 25 %

STW -

NWO Other -

Industry 25 %

TNO -

GTI 25 %

EU -

Scholarships -

START OF THE PROJECT

1996

INFORMATION

C Vuik

015 278 5530

c.vuik@tudelft.nl

<http://ta.twi.tudelft.nl/users/vuik>**PROJECT AIM**

The purpose is to improve efficiency of solution methods in computational fluid Dynamics, porous media flow and related applications. The DICCG (deflated preconditioned conjugate gradients) method will be developed further. The method will be generalized such that reliable termination criteria can be applied. Domain subdivision methods will be developed to make DICCG applicable.

PROGRESS

The SEPRAN code is parallelized and works efficiently on parallel platforms. More and more users are simulating with the parallel version. This leads to useful feedback in order to enhance the solver. Theoretically the deflation acceleration is compared with an additive coarse grid correction and a balancing Neumann Neumann preconditioner. It appears that the deflation method leads to the fastest convergence, whereas the work per iteration is less or equal to the other methods. Many (in)compressible Navier-Stokes equation solvers use a splitting method to solve the discretized equation. In many applications, especially in bubbly flows, the pressure equation takes most of the time to be solved. One of the reasons is the jump in the density in gas and water. Multi grid methods can be used but some difficulties remain if the size of the bubbles is very small. In this project the pressure equation is solved by the deflated ICCG method. After optimization it appears that the resulting method is 4-5 times faster than the ICCG method. We plan to make a better choice of the projection vectors and try to combine it with domain decomposition and parallel computing.

DISSERTATIONS

1. GPU acceleration of preconditioned solvers for ill-conditioned linear systems.
Author: Gupta, R. Promotor: Vuik, C. · Van Gijzen, M.B. Faculty: Electrical Engineering, Mathematics and Computer Science Department: Applied mathematics. Date: 2015-11-09. ISBN: 978-94-6186-526-7

SCIENTIFIC PUBLICATIONS

1. R. Gupta and D. Lukarski and M.B. van Gijzen and C. Vuik Evaluation of the Deflated Preconditioned CG method to solve Bubbly and Porous Media Flow Problems on GPU and CPU International Journal for Numerical Methods in Fluids, 1, pp. 1-2, 2015.

SOLUTION METHODS FOR NAVIER-STOKES PROBLEMS

PROJECT AIM

New preconditioners for the discretized Navier-Stokes equations will be developed. Parallel deflation methods will be included.

PROGRESS

The discrete Navier-Stokes equations are solved by the SIMPLE(R) iteration method. To decrease the very large number of iterations, we have proposed multigrid and Krylov accelerated versions: GCR-SIMPLE(R). The properties of these methods are being investigated for simple two-dimensional flows and three-dimensional flows in industrial glass melting furnaces. These methods are generalised to a colocated discretization and combined with the deflated multiblock approach and parallel computing. Now we try to generalize these solvers to our FEM discretization (SEPRAN) and compare our methods with the recently developed methods given by Elman, Wathen, Sylvester, Benzi, Reusken and Schilders. It appears that MSIMPLER, a new variant of SIMPLER, leads to the fastest results. We also develop a solver based on the Schur complement and multigrid. This method is scalable and leads to very good results for geophysical applications. The GCR-simple solver is also implemented and tested in MARIN software. This lead to a speed-up with a factor 5.

DISSERTATIONS

1. Preconditioning Optimal Flow Control Problems Using Multilevel Sequentially Semiseparable Matrix Computations. Author: Qiu, Y. Promotor: Vuik, C. • Van Gijzen, M.B. • Verhaegen, M. Faculty: Electrical Engineering, Mathematics and Computer Science. Department: Delft Institute of Applied Mathematics. Date: 2015-12-07. ISBN: 9789461865663

SCIENTIFIC PUBLICATIONS

1. C. Vuik Is it finally possible to predict earthquakes? The Guardian, May 20, 2015.
2. Yue Qiu and Martin B. van Gijzen and Jan-Willem van Wingerden and Michel Verhaegen and Cornelis Vuik Efficient preconditioners for PDE-constrained optimization problem with a multilevel sequentially semiseparable matrix structure ETNA, 44, pp. 367-400, 2015.
3. P. van Slingerland and C. Vuik Scalable two-level preconditioning and deflation based on a piecewise constant subspace for (SIP)DG systems for diffusion problems Journal of Computational and Applied Mathematics, 275, pp. 61-78, 2015.
4. X. He and M. Neytcheva and C. Vuik On preconditioning of incompressible non-Newtonian flow problems Journal of Computational Mathematics, 33, pp. 33-58, 2015.
5. Yue Qiu and Martin B. van Gijzen and Jan-Willem van Wingerden and Michel Verhaegen and Cornelis Vuik Convergence Analysis of the Multilevel Sequentially Semiseparable Preconditioners Delft University of Technology Delft Institute of Applied Mathematics Report 15-01.
6. Yue Qiu and Martin B. van Gijzen and Jan-Willem van Wingerden and Michel Verhaegen and Cornelis Vuik Preconditioning Optimal In-Domain Control of Navier-Stokes Equation Using Multilevel Sequentially Semiseparable Matrix Computations Delft University of Technology Delft Institute of Applied Mathematics Report 15-06.

PROJECTLEADERS

C Vuik

RESEARCHTHEME

Complex dynamics of fluids

PARTICIPANTS

C Vuik, S MacLaclan, Geenen, A Segal, P van Slingerland

COOPERATIONS

TNO-Science and Industry
Utrecht University, Septra Tufts
University USA, MARIN

FUNDED

STW, TUD, TNO-Science and
Industry, Nuffic-HEC, MARIN
University 25 %
FOM -
STW -
NWO Other -
Industry 75 %
TNO -
GTI -
EU -
Scholarships -

START OF THE PROJECT

1992

INFORMATION

C Vuik
015 278 5530
c.vuik@tudelft.nl
<http://ta.twi.tudelft.nl/users/vuik>

PROJECTLEADERS

C Vuik, FJ Vermolen

RESEARCHTHEME

Complex dynamics of fluids

PARTICIPANTS

D Ibrahim, FJ Vermolen, C Vuik,
WK van Wijngaarden-van Rossum

COOPERATIONS

-

FUNDED

Deltares	
University	25 %
FOM	-
STW	-
NWO Other	-
Industry	75 %
TNO	-
GTI	-
EU	-
Scholarships	-

START OF THE PROJECT

2007

INFORMATION

FJ Vermolen
015 278 7298
F.J.Vermolen@tudelft.nl
<http://ta.twi.tudelft.nl/users/vermolen>

PROJECT AIM

Develop numerical methods for industrial flow problems.

PROGRESS

A numerical method to cope with pressure boundary conditions on a extraction well has been constructed and analysed. The method is based on a finite-element discretization over the well where the integral boundary condition is evaluated as a boundary value problem. Oscillations are suppressed by the use of SUPG-techniques. Furthermore, a theorem has been formulated and proved about the shift of the spectrum of eigenvalues to the finite-element operator resulting from a standard and SUPG discretization of the boundary value problem. Besides this result, a model for the placement of bacteria has been coupled to the actual fortification model for soils. Next to this work, an experimental validation for the two-dimensional case of the model has been performed and a paper has been submitted about this issue to Transport in Porous Media. Furthermore, Menel Rahrah has started her PhD-project on DSI financed by STW. She works on poro-elasticity models to model the interaction between mechanical vibrations and fast flow of water through the soil at building sites.

DISSERTATIONS

-

SCIENTIFIC PUBLICATIONS

1. J.H. van der Linden, T.B. Jonsthoel, A.A. Lukyanov, C. Vuik The Parallel Subdomain-Levelset Deflation Method in Reservoir Simulation <http://arxiv.org/abs/1510.02148> https://www.researchgate.net/publication/282613113_THE_PARALLEL_SUBDOMAIN-LEVELSET_DEFLATION_METHOD_IN_RESERVOIR_SIMULATION.

TWO-PHASE RESPIRATORY FLOW

PROJECT AIM

The purpose of the project is to extend the Mass Conserving Level Set method to complex domains, by a reformulation for unstructured discretisation of the flow equations, specifically to be able to model two-phase flow in the human respiratory system.

PROGRESS

The earlier proposed extension of the MCLS method for discretisation on general unstructured triangular meshes includes a relatively costly algorithm for the convection of the VoF field. An alternative for this algorithm that can also be used as a stand-alone interface model and is based on a discontinuous Galerkin discretisation of the modified Level-Set field has been investigated. The width of the interface region and the local monotonicity of the solution can be controlled by the application of a compressive velocity field and a dG specific limiter, respectively. Although offering a significant improvement with respect to standard Level-Set based approaches at comparable computational cost, the proposed algorithm can not match the mass-conservation properties of the earlier proposed extension of the MCLS method.

DISSERTATIONS

-

SCIENTIFIC PUBLICATIONS

1. Raees, F., van der Heul, D. R., and Vuik, C. (2015) A mass-conserving level-set method for simulation of multiphase flow in geometrically complicated domains. Int. J. Numer. Meth. Fluids, doi: 10.1002/flid.4188.

PROJECTLEADERS

DR van der Heul

RESEARCHTHEME

Mathematical and computational methods for fluid flow analysis

PARTICIPANTS

F Raees

COOPERATIONS

-

FUNDED

University	-
FOM	-
STW	-
NWO Other	-
Industry	-
TNO	-
GTI	-
EU	-
Scholarships	100 %

START OF THE PROJECT

2011

INFORMATION

DR van der Heul

015 278 2632

D.R.vanderHeul@tudelft.nl

RIGOROUS MODELING OF 3D WAVE PROPAGATION

PROJECT LEADERS

C Vuik, CW Oosterlee

RESEARCH THEME

Complex dynamics of fluids

PARTICIPANTS

C Oosterlee, C Vuik, D Lahaye,
A Sheikh

COOPERATIONS

TUD Chem.Tech, Philips, Shell,
NLR, TU Berlin

FUNDED

SenterNovem, NLR, Nuffic	
University	25 %
FOM	-
STW	-
NWO Other	-
Industry	75 %
TNO	-
GTI	-
EU	-
Scholarships	-

START OF THE PROJECT

2001

INFORMATION

C Vuik
015 278 5530
C.Vuik@tudelft.nl
<http://ta.twi.tudelft.nl/users/vuik>

PROJECT AIM

The aim is to develop efficient parallel iterative solvers for the Helmholtz problem. In order to estimate the layered structure of the earth crust seismic methods are used. The layer structure is used as input for porous media flow simulations.

PROGRESS

A special preconditioner has been developed, which in a special combination of Krylov subspace and multigrid methods has resulted in a hundredfold increase in computing speed for the Helmholtz equation, describing wave propagation. Application in seismics has been very successful, and has generated much interest from the oil exploration industry, especially after a comparison with an industrial code in an application to a practical problem posed by industry. For the first time, realistic three-dimensional applications become feasible. This has already been realized on a single-processor machine for medium-sized problems. The 3D code for the seismic simulation package has been parallelized. Furthermore, a comparison with analytic solutions will be made. The fast solver technique will be generalized to a finite element discretization of the Maxwell equations, for radar simulations.

DISSERTATIONS

-

SCIENTIFIC PUBLICATIONS

-

MODELLING BACTERIALLY INDUCED FLOW DIVERSION IN OIL RESERVOIR

PROJECT AIM

We want to model the intercourse between oil recovery and bacterially developed biofilms in oil reservoirs aiming at flow diversion to produce oil from low permeability regions.

PROGRESS

A mathematical formalism has been developed in terms of a network model to model the development of a biofilm by bacterial colonies. The novelties are a sound model that combines the bacterial activity to bacterial populations as well as to the development rate of the biofilm. The model is used to model different permeability regions with statistical distributions of pore crosssections. A first paper is in progress.

DISSERTATIONS

-

SCIENTIFIC PUBLICATIONS

-

PROJECTLEADERS

FJ Vermolen, B Meulenbroek

RESEARCHTHEME

Mathematical and computational methods for fluid flow analysis

PARTICIPANTS

L Antonio Perez

COOPERATIONS

-

FUNDED

Mexican Institute of Petroleum

University -

FOM -

STW -

NWO Other -

Industry 100 %

TNO -

GTI -

EU -

Scholarships -

START OF THE PROJECT

2014

INFORMATION

FJ Vermolen

015 278 7298

F.J.Vermolen@tudelft.nl

<http://ta.twi.tudelft.nl/users/vermolen>

MODELLING FIBROBLAST BEHAVIOR IN BURNS

PROJECT LEADERS

F.J. Vermolen

RESEARCH THEME

Mathematical and computational methods for fluid flow analysis

PARTICIPANTS

D. Koppenol

COOPERATIONS

Brandwondencentrum Beverwijk

FUNDED

Nederlandse Brandwondenstichting

University -

FOM -

STW -

NWO Other -

Industry 100 %

TNO -

GTI -

EU -

Scholarships -

START OF THE PROJECT

2012

INFORMATION

F.J. Vermolen

015 278 7298

F.J.Vermolen@tudelft.nl

<http://ta.twi.tudelft.nl/users/vermolen>

PROJECT AIM

We want to model the influence of fibroblasts behavior on the occurrence of contractures and hypertrophic scars in burns.

PROGRESS

Four mathematical models have been developed. One model involves the influence of fibrocytes on hypertrophic scars. Another model links the immune response system to the occurrence of contractures. A third model involves the treatment of orthotropic effects and large strains on the occurrence of contractures. All these models are based on partial differential equations. A fourth model is a hybrid model that links a cell-based approach to PDE's for the elasticity and chemicals in around burns. Contractures of burns were modeled in a phenomenological way.

DISSERTATIONS

-

SCIENTIFIC PUBLICATIONS

1. W.M. Boon, D.C. Koppenol, F.J. Vermolen. A multi-agent cell-based model for wound contraction. *Journal of Biomechanics*. Doi:10.1016/j.jbiomech.2015.1.058.

MODELLING WOUND HEALING AND CANCER DEVELOPMENT

PROJECT AIM

We want to model the healing of wounds and initiation of tumors.

PROGRESS

Several cell-based models have been developed. All models are based on semi-stochastic principles and include cell migration, cell differentiation, cell proliferation and cell death. Migration incorporates chemotaxis, durotaxis and random walk. The mathematical equations are stochastic ordinary and partial differential equations.

DISSERTATIONS

-

SCIENTIFIC PUBLICATIONS

1. FJ Vermolen, RP Van der Meijden, M Van Es, A Gefen, D Weihs. Towards a Mathematical Formalism for Semi-stochastic Cell-Level Computational Modeling of Tumor Initiation. *Annals of Bioengineering*, 43(7) 1680-1694 (2015).
2. FJ Vermolen, A Gefen. Semi-stochastic cell-level computational modelling of cellular forces: application to contractures in burns and cyclic loading, *Biomechanics and Mechanobiology*, DOI: 10.1007/s10237-015-0664-2.
3. FJ Vermolen. Short Review of Computational Models for Single Cell Deformation and Migration. *Single Cell Biology*.
4. FJ Vermolen. Particle Methods to solve modeling problems in wound healing and tumor growth. *Computational Particle Dynamics*, 2(4) 381-399 (2015).
5. M Dudaie, D Weihs, FJ Vermolen, A Gefen. Modelling migration in cell colonies in two and three dimensional substrates with varying stiffnesses. In *Silico Cell and Tissue Science*, 2(1) 1-12 (2015).

PROJECTLEADERS

FJ Vermolen

RESEARCHTHEME

Mathematical and computational methods for fluid flow analysis

PARTICIPANTS

J Chen

COOPERATIONS

Tel Aviv University, Technion, Haifa
VUMC, Amsterdam

FUNDED

Nederlandse brandwondenstichting
University -
FOM -
STW -
NWO Other -
Industry 100 %
TNO -
GTI -
EU -
Scholarships -

START OF THE PROJECT

2015

INFORMATION

FJ Vermolen
015 278 7298
F.J.Vermolen@tudelft.nl
<http://ta.twi.tudelft.nl/users/vermolen>

STATE-OF-THE-ART MODELING OF MULTIPHASE FLOW IN LARGE PIPELINE SYSTEMS

PROJECT LEADERS

C Vuik, DR van der Heul

RESEARCH THEME

Mathematical and computational methods for fluid flow analysis

PARTICIPANTS

JSB van Zwieten

COOPERATIONS

Shell

FUNDED

Shell

University -

FOM -

STW -

NWO Other -

Industry 100 %

TNO -

GTI -

EU -

Scholarships -

START OF THE PROJECT

2010

INFORMATION

C Vuik

C.Vuik@tudelft.nl

015 278 85530

PROJECT AIM

The purpose of the project is to develop a robust, efficient and accurate algorithm for the simulation of multiphase flow in large (Length \gg diameter) pipeline systems.

PROGRESS

In the past year we have compared the behaviour of a space-time Discontinuous Galerkin (DG) scheme and a Finite Volume (FV) scheme for a one-dimensional twofluid model subject to sinusoids that grow in time due to a Kelvin-Helmholtz instability. With a k -th order DG scheme the growth rate of the sinusoids converges with order $2k+1$ versus only order k with a k -th order FV scheme, which shows the advantage of DG for analysing Kelvin-Helmholtz related problems. Furthermore we have extended the local refinement in space-time and viscous regularisation to capture shocks and we have made some progress with a DG scheme suitable for twofluid models with vanishing phases.

DISSERTATIONS

-

SCIENTIFIC PUBLICATIONS

1. J.S.B. van Zwieten and B. Sanderse and M.H.V. Hendrix and C. Vuik and R.A.W.M. Henkes. Efficient simulation of one-dimensional two-phase flow with a new high-order Discontinuous Galerkin method, Delft Institute of Applied Mathematics Report 15-07, 2015.

PROJECT AIM

The purpose of the project is to obtain a better understanding of the transition from stable to unstable multiphase flow in pipeline systems through numerical simulations.

PROGRESS

Moving towards turbulent multiphase flows, a second order mimetic finite difference discretization of the Navier Stokes equations in cylindrical coordinates has been derived that simultaneously conserves mass, momentum and kinetic energy (in the case of vanishing viscosity). A consistent treatment of the coordinate singularity is shown to be an integral part of discrete energy conservation. Furthermore, the fully cylindrical MCLS algorithm is applied to the prediction of interface instabilities in stratified pipe flows. The finite volume approach of the interface around the coordinate singularity proves to be challenging and is an on-going topic of research.

DISSERTATIONS

-

SCIENTIFIC PUBLICATIONS

-

PROJECTLEADERS

DR van der Heul

RESEARCHTHEME

Mathematical and computational methods for fluid flow analysis

PARTICIPANTS

G Oud

COOPERATIONS

SHELL, Deltares, TNO

FUNDED

SHELL, DELTARES, TNO

University	-
FOM	-
STW	-
NWO Other	-
Industry	100 %
TNO	-
GTI	-
EU	-
Scholarships	-

START OF THE PROJECT

2011

INFORMATION

DR van der Heul

015 278 2632

D.R.vanderHeul@tudelft.nl

ISOGEOMETRIC ANALYSIS OF TWO-PHASE FLOWS WITH THE CAHN-HILLIARD PHASE FIELD MODE

PROJECT LEADERS

S Turek, M Möller

RESEARCH THEME

Mathematical and computational methods for fluid flow analysis

PARTICIPANTS

BS Hosseini, M Möller

COOPERATIONS

-

FUNDED

University -
FOM -
STW -
NWO Other -
Industry -
TNO -
GTI -
EU -
Scholarships -

START OF THE PROJECT

2011

INFORMATION

M Möller
015 278 9755
M.Moller@tudelft.nl
<http://ta.twi.tudelft.nl/nw/users/matthias>

PROJECT AIM

Develop an efficient isogeometric analysis framework for the simulation of multi-physics problems. Concrete problems to be considered are two-phase flow problems solved by the Cahn-Hilliard phase field model.

PROGRESS

The PhD-candidate finished a prototypical implementation of a single-phase incompressible flow solver based on the isogeometric analysis approach (NURBS-based) and validated it against standard benchmarks for the Navier-Stokes equations. Recent research activities focus on the extension of the code towards two-phase flows. The PhD candidate is working on the implementation and validation of an IgA-based solver for the Cahn-Hilliard phase field model.

DISSERTATIONS

-

SCIENTIFIC PUBLICATIONS

1. B. Hosseini, M. Möller, and S. Turek: A numerical study of Isogeometric Analysis for cavity flow and flow around a cylindrical obstacle, *Appl. Math. Comput.* 276 (2015), 264-281, DOI: 10.1016/j.amc.2015.03.104.

PREDICTING CRITICAL CONDITIONS FOR THE SELF HEALING MECHANISM OF CONCRETE

PROJECT AIM

We want to model self healing of concrete.

PROGRESS

A paper has been written about the past work that was carried out in the framework of self-healing materials.

DISSERTATIONS

-

SCIENTIFIC PUBLICATIONS

1. FJ Vermolen, S. Zemskov. Modelling approaches for self-healing mechanisms in concrete. In e-book Self Healing Materials, edited by S. van der Zwaag and Eelco Brinkman (2015) DOI: 10.3233/978-1-61499-514-2-149.

PROJECTLEADERS

FJ Vermolen

RESEARCHTHEME

Mathematical and computational methods for fluid flow analysis

PARTICIPANTS

S Zemskov

COOPERATIONS

Civil engineering

FUNDED

Agentschap NL

University -

FOM -

STW -

NWO Other -

Industry -

TNO -

GTI -

EU -

Scholarships 100 %

START OF THE PROJECT

2012

INFORMATION

F Vermolen

015 278 7298

F.J. Vermolen

<http://ta.twi.tudelft.nl/users/vermolen>

NUMERICAL SIMULATION OF ROTARY KILNS FOR THE PRODUCTION OF ALUMINUM CEMENT

PROJECT LEADERS

DJP Lahaye, C Vuik, R Sadi

RESEARCH THEME

Mathematical and computational methods for fluid flow analysis

PARTICIPANTS

M el Abbassi

COOPERATIONS

-

FUNDED

Almatis BV
University -
FOM -
STW -
NWO Other -
Industry 100 %
TNO -
GTI -
EU -
Scholarships -

START OF THE PROJECT

2015

INFORMATION

D Lahaye
015 278 3257
d.j.p.lahaye@tudelft.nl
http://ta.twi.tudelft.nl/nw/users/domenico/rotary_kiln/rotary_kiln.html

PROJECT AIM

This project aims at increasing the productivity of an operational unit for the production of aluminum cement while decreasing its environmental impact. The first aim is to simulate the heat released by the non-premixed turbulent combustion of gaseous hydrocarbon fuels. To this end the numerical simulation of turbulent reactive flows will be looked into. The second aim is to simulate the sintering processes that occur as the raw material travels through the furnace. To this end models for the mixing and heat absorption for the material will be studied.

PROGRESS

The project builds upon a previous internship and two master thesis projects. The PhD project only recently started and resulted in preliminary simulations. The PhD student is currently following courses and writing a literature study report.

DISSERTATIONS

-

SCIENTIFIC PUBLICATIONS

-

MODELING BIOGROUT

PROJECT AIM

We want to understand the physics behind the biogrout process so that the process can be improved. The BIOGROUT process aims at bacterially reinforce weak soils.

PROGRESS

An experimental validation of the models that were developed by van Wijngaarden has been carried out.

DISSERTATIONS

-

SCIENTIFIC PUBLICATIONS

1. W.K. van Wijngaarden, L.A. van Paassen, F.J. Vermolen, G.A.M. van Meurs, C. Vuik. A reactive transport model for biogrout compared to experimental data. Transport in Porous Media, DOI 10.1007/s11242-015-0615-5.

PROJECTLEADERS

FJ Vermolen

RESEARCHTHEME

Mathematical and computational methods for fluid flow analysis

PARTICIPANTS

M van Wijngaarden–van Rossum,
G van Meurs (Deltares), C Vuik
(TUD)

COOPERATIONS

Deltares

FUNDED

Agentschap NL
University -
FOM -
STW -
NWO Other -
Industry 100 %
TNO -
GTI -
EU -
Scholarships -

START OF THE PROJECT

2014

INFORMATION

F Vermolen
015 278 7298
F.J. Vermolen
<http://ta.twi.tudelft.nl/users/vermolen>

FAST HIGH VOLUME INFILTRATION

PROJECT LEADERS

FJ Vermolen

RESEARCH THEME

Mathematical and computational methods for fluid flow analysis

PARTICIPANTS

M Rahrah

COOPERATIONS

Utrecht University, Fugro, Guido van Tongeren

FUNDED

STW	
University	-
FOM	-
STW	100 %
NWO Other	-
Industry	-
TNO	-
GTI	-
EU	-
Scholarships	-

START OF THE PROJECT

2014

INFORMATION

F Vermolen
015 278 7298
F.J. Vermolen
<http://ta.twi.tudelft.nl/users/vermolen>

PROJECT AIM

We want to understand the physics behind the infiltration of water through a nozzle into the subsurface.

PROGRESS

A numerical scheme has been developed for the approximation of the solution of the Biot poro-elasticity equations. Here we are interested in the interaction between mechanical vibrations and fluid flow. Further a paper is being written.

DISSERTATIONS

-

SCIENTIFIC PUBLICATIONS

-



MATHEMATICAL PHYSICS



Prof.dr.ir. AW Heemink



Prof.dr.ir. ELC Deleersnijder

The central research direction of the group is the mathematical modeling of physical phenomena using (partial) differential equations. The research is application driven and includes the modeling phase, analysis of the model and the numerical implementation of the model. The focus is now more and more on the research themes:

INVERSE MODELING AND DATA ASSIMILATION

Data assimilation methods are used to combine the results of a large scale numerical model with the measurement information available in order to obtain an optimal reconstruction of the dynamic behavior of the model state. Many data assimilation schemes are based on solving the Euler-Lagrange equations. A recursive algorithm to solve this two-point boundary value problem can be derived and results in the well-known Kalman filtering algorithm. Variational data assimilation is also a powerful method, but requires the implementation of the adjoint (of the tangent linear approximation) of the numerical model. In a series of externally funded PhD projects the mathematical algorithms have been developed and applied in a number of real life applications:

- Tidal flow models (funding: Rijkswaterstaat)
- Atmospheric-chemistry modeling (funding: NWO, TNO, RIVM).
- Oil reservoir modeling (Funding: Shell, TNO).

PERTURBATION METHODS FOR PARTIAL DIFFERENTIAL EQUATIONS

The main focus within this theme is to develop perturbation methods to analyse initial value problems and initial-boundary value problems for partial differential equations. The applications are in a variety of fields, such as: the wind flow (or rain-wind) induced oscillations of bridges, high-rise buildings, or of overhead power transmission lines; the vibrations of conveyor belts; and the morphodynamics in tidal embayments.

HIGH PERFORMANCE COMPUTING AND PARALLEL ALGORITHMS

This research theme aims to design efficient and scalable parallel algorithms and apply high performance computing technology to applications, such as the storm surge forecasting and pollutant transport in North Sea or rivers. Domain decomposition and grid partitioning is an effective approach for parallel simulation of models described by partial differential equations. Sparse matrices typically occur in numerical simulation of problems described by partial differential equations. One of our research focus is on designing parallel algorithms for solving sparse matrix systems. Lagrangian models, often also called particle models, for transport problems in coastal waters, can deal with steep gradients of concentration. Because the movements of the particles are largely independent from each other, so particle models are very suited for parallel and distributed computing. We have developed parallel models for transport problems of the Dutch coastal water (e.g., Wadden sea). Currently, a particle model with adaptive time steps is being developed, besides the derivation of the numerical scheme the additional challenge is to maintain a good load balance in an adaptive scheme. Grid computing is the next step of development in high performance computing.

MODELLING AND FORECAST OF VULCANCO ASH DISTRIBUTION

PROJECT AIM

The research aims at modelling of the distribution of volcano ash where measurements of satellite and aircraft are used to improve the forecast accuracy.

PROGRESS

The research focuses on modelling the transport process of the volcanic ash. The performance and shortcomings of existing Ensemble Kalman filter techniques and 4D variational methods are studied given the constraints and limitations of exiting measurements. To overcome spurious correlations in typical data assimilation of vulcano ash distribution process, a trajectory-based 4DVar method has been proposed to overcome the problem of spurious correlation caused by the insufficiency of data (lack of vertical resolution of satellite data), and an efficient back-trace localization scheme is designed to reduce the spurious correlations caused by finite ensemble size in EnKF.

DISSERTATIONS

-

SCIENTIFIC PUBLICATIONS

1. G. Fu · H.X. Lin · A.W. Heemink · A.J. Segers · S. Lu · T. Palsson, Assimilating aircraft-based measurements to improve Forecast Accuracy of Volcanic Ash Transport, Atmospheric Environment, Vol. 115, pp. 170-184.
2. S. Lu, H.X. Lin, A.W. Heemink, G. Fu, A. Segers, Estimation of volcanic ash emissions using trajectory-based 4D-Var data Assimilation, Monthly Weather Review, Vol. 144, pp. 575-589.

PROJECTLEADERS

AW Heemink, HX Lin

RESEARCHTHEME

Mathematical and computational methods for fluid flow analysis

PARTICIPANTS

HX Lin, GL Fu, JB Jin, S Lu

COOPERATIONS

TNO, Reykjavik University, Iceland

FUNDED

University	50 %
FOM	-
STW	-
NWO Other	-
Industry	-
TNO	-
GTI	-
EU	-
Scholarships	50 %

START OF THE PROJECT

2012

INFORMATION

HX Lin

015 278 7229

H.X.Lin@tudelft.nl

<http://mathematicalphysics.ewi.tudelft.nl>

tudelft.nl

DATA ASSIMILATION IN CFD

PROJECT LEADERS

AW Heemink

RESEARCH THEME

Mathematical and computational methods for fluid flow analysis

PARTICIPANTS

MDLC Rojas Larrazabal,
RG Hanea, MU Altaf, C van Velzen,
M Verlaan, AW Heemink, SP Szklarz

COOPERATIONS

Deltares, RIVM, Shell, MIT,
TNO, Vortech

FUNDED

Deltares, Shell, TNO, NWO	
University	10 %
FOM	-
STW	-
NWO Other	10 %
Industry	20 %
TNO	30 %
GTI	20 %
EU	-
Scholarships	10 %

START OF THE PROJECT

2001

INFORMATION

AW Heemink
015 278 5813
a.w.heemink@tudelft.nl

PROJECT AIM

Large scale numerical models are often used for prediction problems. These models however are far from perfect. The model predictions can be improved by assimilating measurements into the model using a Kalman filter. A serious problem with this approach is that the standard filter algorithm imposes a very large burden on the computer. In order to obtain a computationally efficient filter, simplifications have to be introduced. Model reduction is a corner stone in developing sub-optimal schemes. In this project new sub-optimal algorithms to solve large scale Kalman filtering problems are developed.

PROGRESS

We have developed a model reduction methodology for large scale numerical models in cooperation with TNO, Shell and Deltares. New PhD projects around the theme "Smart Wells" in cooperation with the faculty CiTG, MIT and Shell have started. In these PhD projects we will develop and apply model reduction and filtering techniques for assimilating data into multi-phase flow models in order to solve reservoir engineering problems. New application areas are also ecological coastal sea models and morphodynamic models.

DISSERTATIONS

-

SCIENTIFIC PUBLICATIONS

1. Fu, G, Lin, HX, Heemink, AW, Segers, AJ, Lu, S & Palsson, T (2015). Assimilating aircraft-based measurements to improve forecast accuracy of volcanic ash transport. *Atmospheric Environment*, 115, 170-184.
2. Toorn, R van der, Heemink, AW, Verlaan, M, Gerkema, T & Haren, H van (). Where Applied Mathematics, Hydrodynamics and Ocean Science meet: Diagnostic, Modeling & Sea Going Assessments of Global- and Internal Tides. In *Oceanography 2015. Omics International Conferences*.
3. Garcia, M, Ramirez, I, Verlaan, M & Castillo, J (2015). Application of a three-dimensional hydrodynamic model for San Quintin Bay, BC, Mexico. Validation and calibration using OpenDA. *Journal of Computational and Applied Mathematics*, 273, 428-437.
4. Mazzoleni, M, Verlaan, M, Alfonso, L, Monego, M, Norbiato, D, Ferri, M & Solomatine, DP (2015). Can assimilation of crowdsourced streamflow observations in hydrological modelling improve flood prediction? *Hydrology and Earth System Sciences Discussions*, 12, 11371-11419.
5. Zijl, F, Sumihar, JH & Verlaan, M (2015). Application of data assimilation for improved operational water level forecasting on the northwest European shelf and North Sea. *Ocean Dynamics: theoretical, computational oceanography and monitoring*, 65(12), 1699-1716.

PERTURBATION METHODS FOR PARTIAL DIFFERENTIAL EQUATIONS

PROJECT AIM

The main focus within this project is to develop and to apply perturbation methods to analyze initial value problems and (initial)boundary value problems for partial differential equations. The applications are in a variety of fields, such as: the wind or rain-wind induced oscillations of elastics structures (such as bridges, high-rise buildings, and overhead power transmission lines); the vibrations of conveyor belts and elevator cables; the morphodynamic evolution of coastal systems (such as beaches, and estuaries); and the dynamics of polymers in shear flow.

PROGRESS

In 2015 the applicability of different types of perturbation methods was investigated. For problems with boundary damping, for nonselfadjoint problems, for weakly nonlinear problems, and for problems with variable coefficients all kinds of computational aspects have been studied by using perturbation methods, methods from dynamical system theory, numerical methods, and stochastic methods.

DISSERTATIONS

1. Idealised modelling of storm surges in large-scale coastal basins, PhD thesis University of Twente, Chen, WenLong, 16 December 2015, promotor: S.J.H.M. Hulscher, co-promotoren: P.C. Roos, H.M. Schuttelaars.

SCIENTIFIC PUBLICATIONS

1. Akkaya, T & Horssen, WT van (2015). Reflection and damping properties for semi-infinite string equations with non-classical boundary conditions. *Journal of Sound and Vibration*, 336(February 2015), 179-190.
2. Gaiko, N & Horssen, WT van (2015). On the transverse, low frequency vibrations of a traveling string with boundary damping. *Journal of Vibration and Acoustics*, 137(4).
3. Kurowicka, D & Horssen, WT van (2015). On an interaction function for copulas. *Journal of Multivariate Analysis*, 138, 127-142.
4. Malookani, RA & Horssen, WT van (2015). On resonances and the applicability of Galerkin's truncation method for an axially moving string with time-varying velocity. *Journal of Sound and Vibration*, 344, 1-17.
5. Sandilo, SH & Horssen, WT van (2015). On a cascade of autoresonances in an elevator cable system. *Nonlinear Dynamics: an international journal of nonlinear dynamics and chaos in engineering systems*, 80(3), 1613-1630.
6. Horssen, WT van (2015). On the mathematical analysis of vibrations of axially moving strings and beams. In J Awrejcewicz, M Kazmierczak, J Mrozowski & P Olejnik (Eds.), *Dynamical Systems, control and stability* (pp. 591-602). Lodz: Department of Automation, Biomechanics and Mechatronics.
7. Chen, WL, Roos, PC, Schuttelaars, HM & Hulscher, SJMH (2015). Resonance properties of a closed rotating rectangular basin subject to space- and time-dependent wind forcing. *Ocean Dynamics: theoretical, computational oceanography and monitoring*, 65(3), 325-339.
8. Ensing, E, Swart, H.E. de & Schuttelaars, HM (2015). Sensitivity of tidal motion in well-mixed estuaries to cross-sectional shape, deepening, and sea level rise. *Ocean Dynamics: theoretical, computational oceanography and monitoring*, 65(7), 993-950.

PROJECTLEADERS

AW Heemink

RESEARCHTHEME

Mathematical and computational methods for fluid flow analysis

PARTICIPANTS

WT van Horssen, HM Schuttelaars, JLA Dubbeldam, T Akkaya, N Gaiko, R Ali, M Kumar, X Wei, K Xi, Y Dijkstra, J Jianbing

COOPERATIONS

-

FUNDED

University	60 %
FOM	-
STW	-
NWO Other	10 %
Industry	10 %
TNO	-
GTI	-
EU	-
Scholarships	20 %

START OF THE PROJECT

2003

INFORMATION

WT van Horssen

015 278 3524

W.T.vanHorssen@tudelft.nl

<http://math.ewi.tudelft.nl>

9. Purkiani, K, Becherer, J, Floser, G, Grawe, U., Mohrholz, V, Schuttelaars, HM & Burchard, H (2015). Numerical analysis of stratification and destratification processes in a tidally energetic inlet with an ebb tidal delta. *Journal Of Geophysical Research-Oceans*, 120(1), 225-243.
10. Roos, PC & Schuttelaars, HM (2015). Resonance properties of tidal channels with multiple retention basins: role of adjacent sea. *Ocean Dynamics: theoretical, computational oceanography and monitoring*, 65(3), 311-324.
11. Schulz, E., Schuttelaars, HM, Grawe, U. & Burchard, H (2015). Impact of the Depth-to-Width Ratio of Periodically Stratified Tidal Channels on the Estuarine Circulation. *Journal of Physical Oceanography*, 45(8), 2048-2069.
12. Dubbeldam, JLA, Tomovski, Z & Sandev, T (2015). Space-Time Fractional Schrödinger Equation With Composite Time Fractional Derivative. *Fractional Calculus and Applied Analysis*, 18(5), 1179-1179.
13. Zhao, D, Zhu, Q & Dubbeldam, JLA (2015). Terminal sliding mode control for continuous stirred tank reactor. *Chemical Engineering Research and Design*, 94(February), 266-274.



TRANSPORT PHENOMENA



Prof.dr.ir. CR Kleijn



Prof.dr. RF Mudde



Prof.dr.ir. HEA van den Akker

The Transport Phenomena group studies the transport of mass, momentum and heat, on different length and time scales, in physical, biological and chemical processes related to advanced materials processing, energy conversion and storage, and health. The main interest is in transport phenomena around (solid-fluid, liquid-gas and liquid-liquid) interfaces, which we wish to understand, control and enhance.

The group uses both theoretical and computational models, and non-intrusive experiments based on laser and X-ray techniques.

Our expertise is in heat and mass transfer in multiphase flows, turbulent flows, microflows and biological flows.

A partial list of topics which we currently work on:

- Multiphase flow and dynamic contact line phenomena in digital microfluidics and Labs-on-Chips
- Dispersed multiphase flows in large scale chemical processing (bubble columns, fluidized beds, Fischer Tropsch)
- Magnetohydrodynamics in advanced liquid metal processing (welding, casting)
- Magnetic drug targeting
- Oil-water separation
- Turbulence modulation for enhanced heat and mass transfer

Prof.dr. de Haan

Prof.dr.ir. K Hanjalic

HYBRID RANS/LES SIMULATIONS OF TURBULENT FLOWS OVER HILLS AND COMPLEX URBAN AREAS WITH DISPERSION OF POLLUTANTS

PROJECT AIM

This project is aimed at the mathematical modelling and numerical simulations of environmental flows and turbulent dispersion of passive and reactive scalars. In this particular project we focus our investigation at turbulent flows over complex terrains and urban areas (street canyons) partially covered with vegetation and with different sources of the passive or reactive scalars. In the last year, the special focus was on the dynamics of reactive scalars to mimic the ozone generation or depletion.

PROGRESS

We developed a new class of the seamless hybrid RANS/LES approach suitable for the complex urban areas partially covered with vegetation. We successfully reproduced detailed laboratory-scale measurements for different geometrical configurations reported in literature. Also, the mechanism of the ozone generation/depletion in urban areas due to traffic emission is validated.

DISSERTATIONS

-

SCIENTIFIC PUBLICATIONS

1. Kenjeres S. (2015), "Heat transfer enhancement induced by wall inclination in turbulent thermal convection", *Physical Review E*, Vol.92 (5), Art. No. 053006, pp.1-14 (doi: 10.1103/PhysRevE.92.053006)
2. Mirkov N., Rasuo B., Kenjeres S. (2015), "On the improved finite volume procedure for simulation of turbulent flows over real complex terrains", *Journal of Computational Physics*, Vol. 287, pp.18-45, (doi: 10.1016/j.jcp.2015.02.001)
3. Schrijvers P.J.C., Jonker H.J.J., Kenjeres S. and de Roode S. R. (2014), "Breakdown of the night time urban heat island energy budget", *Energy and Buildings*, Vol.83, pp. 50-64, (doi: 10.1016/j.buildenv.2014.08.012)
4. S. Kenjeres (2015), "On modelling and simulations of traffic induced smog formation in complex urban areas", *Proceedings of the XXV International JUMV Automotive Conference, Science and Motor Vehicles with Exhibition*, April 14-15, 2015, Belgrade, Serbia, Invited Paper.
5. C. Muilwijk, P. J. C. Schrijvers and S. Kenjereš (2015), "On modeling and simulations of photochemical smog formation in simplified and complex urban areas", *The 8th International Symposium on Turbulence, Heat and Mass Transfer*, September 15-18, 2015, Sarajevo, Bosnia and Herzegovina, Eds. Hanjalic et al., Begell House Inc., pp.727-730.

isosurfaces of the vertical velocity, turbulent kinetic energy (kM) and pollutant concentration (C) within a complex urban area. An instantaneous snapshot from the newly developed seamless hybrid RANS/LES method.

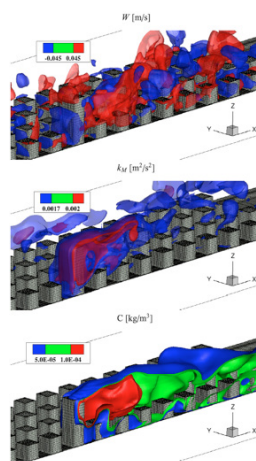

PROJECT LEADERS

S Kenjeres

RESEARCH THEME

Complex dynamics of fluids

PARTICIPANTS

S Kenjeres

COOPERATIONS

Prof. H.J. Jonker, CITG, TUD

Dr. S. Roode, CiTG, TUD

Dr. N. Mirkov, University of Belgrade

and Vinca Institute of Nuclear Science, Belgrade, Serbia

FUNDED

University 100 %

FOM -

STW -

NWO Other -

Industry -

TNO -

GTI -

EU -

Scholarships -

START OF THE PROJECT

2010

INFORMATION

S Kenjeres

015 278 3649

S.Kenjeres@tudelft.nl

www.msp.tudelft.nl

THERMO-MAGNETIC CONVECTION IN PRESENCE OF STRONG MAGNETIC FIELD GRADIENTS EXPERIMENTAL AND NUMERICAL STUDIES

PROJECT LEADERS

S Kenjeres

RESEARCH THEME

Complex dynamics of fluids

PARTICIPANTS

S. Kenjeres, J. S. Szmyd,
E. Fornalik-Wajs

COOPERATIONS

AGH University of Science and
Technology, Krakow, Poland

FUNDED

AGH University of Science
and Technology, Krakow,
Poland, EC Marie Curie
University 50 %

FOM -

STW -

NWO Other -

Industry -

TNO -

GTI -

EU 50 %

Scholarships -

START OF THE PROJECT

2010

INFORMATION

S Kenjeres

015 278 3649

S.Kenjeres@tudelft.nl

PROJECT AIM

This is a joint project between Transport Phenomena Section, Department of Chemical Engineering at the TU Delft and the Department of Fundamental Research in Energy Engineering, Faculty of Energy and Fuels, AGH University of Science and Technology, Krakow, Poland. The project is aimed at fundamental investigations of flow stability and wall heat transfer of paramagnetic fluids in presence of strong magnetic field gradients

PROGRESS

Experimental measurements of the integral heat transfer performed over a range of working parameters for a differentially heated cubical enclosure of a paramagnetic fluid subjected to magnetic gradients of different orientation and strength. DNS studies of the flow and heat transfer performed and detailed comparison with experiments performed. Detailed insights into mechanism of the wall-heat transfer enhancement or suppression provided.

DISSERTATIONS

-

SCIENTIFIC PUBLICATIONS

1. S. Kenjeres (2015), "The wall-heat transfer control in turbulent thermo-magnetic convection", International Conference on Rayleigh-Bénard Turbulence, 1-5 June 2015, Max Planck Institute for Dynamics and Self-Organisation, Gottingen, Germany
2. S. Kenjeres, R. Zinsmeister, L. Pyrda, E.Fornalik-Wajs, J. Szmyd (2015), "Modulation of the wall-heat transfer in turbulent thermomagnetic convection by magnetic field gradients", The 15th European Turbulence Conference, ETC-15, Delft, The Netherlands, pp.1-6
3. S. Kenjereš, R. Zinsmeister, L. Pyrda, E. Fornalik-Wajs and J. S. Szmyd (2015), "Turbulence budgets in confined thermomagnetic convection", The 8th International Symposium on Turbulence, Heat and Mass Transfer, September 15-18, 2015, Sarajevo, Bosnia and Herzegovina, Eds. Hanjalic et al., Begell House Inc., pp.799-802.

Iso-surfaces of the temperature for different strengths of the imposed magnetic field, $|b_0|_{max}=0$ and 2 T (i.e. the magnetization number is 0 and 2.34) and a fixed value of $Pr=400$ (the steady laminar flow regime of the paramagnetic fluid).

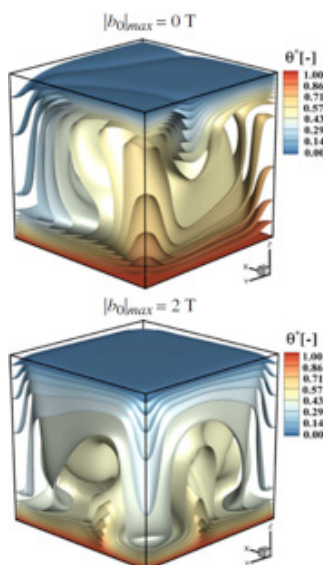

NUMERICAL SIMULATIONS AND EXPERIMENTS OF FLOW, TURBULENCE AND MASS TRANSFER CONTROL OF ELECTRICALLY CONDUCTING FLUIDS BY IMPOSED ELECTROMAGNETIC FIELDS

PROJECT AIM

Numerical simulations and modeling of thermal and magnetic convection at very high Rayleigh and Hartmann numbers has long been a serious challenge because of the profound effects that buoyancy and Lorentz forces have on the reorganization of the vortical structures, and because of the extreme thinning of the wall boundary layers which requires high numerical resolution. The aim of this study is to develop physically well-based and numerically efficient approaches to tackle problems of highly turbulent thermal and magnetic convection in complex geometries.

PROGRESS

We performed DNS studies of flow around magnetic obstacles in transitional and turbulent flow regimes. A new model for the subscale turbulent heat flux for low-Pr fluids is proposed.

DISSERTATIONS

-

SCIENTIFIC PUBLICATIONS

1. Kenjeres, S. (2015), "On Turbulence Generation and Mixing in the Wake of Magnetic Obstacles: A DNS Study", J. Frohlich et al. (eds.), Direct and Large-Eddy Simulation IX, ERCOFTAC Series 20, Springer, ISBN 978-3-319-14447-4, pp.577-583 (DOI: 10.1007/978-3-319-14448-1_73)

PROJECT LEADERS

S Kenjeres, CR Kleijn

RESEARCH THEME

Complex dynamics of fluids

PARTICIPANTS

S Kenjeres

COOPERATIONS

-

FUNDED

TU Delft

University 100 %

FOM -

STW -

NWO Other -

Industry -

TNO -

GTI -

EU -

Scholarships -

START OF THE PROJECT

2006

INFORMATION

S Kenjeres

015 278 3649

S.Kenjeres@tudelft.nl

Figure: Instantaneous vertical vorticity in flow around magnetic obstacle(s): one- (top), two- (middle) and three- (bottom) magnetic dipole(s), with laminar approaching conditions, $Re=1000$ and high electric conductivity (interaction number $N=10$).

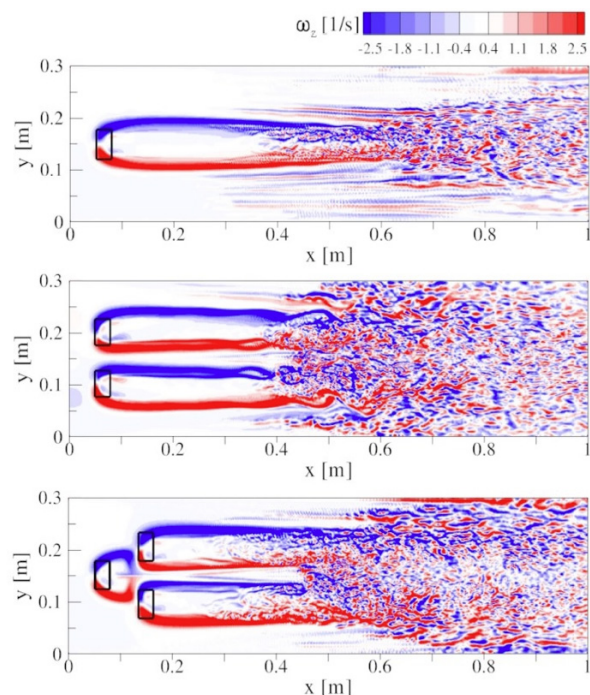

NUMERICAL MODELING AND SIMULATIONS OF BLOOD FLOW AND MAGNETIC PARTICLES IN SIMPLIFIED AND REALISTIC ARTERIAL GEOMETRIES: TOWARDS OPTIMIZED MAGNETIC DRUG DELIVERY

PROJECT LEADERS

S Kenjeres

RESEARCH THEME

Complex dynamics of fluids

PARTICIPANTS

S Kenjeres

COOPERATIONS

ERASMUS Medical Center
Rotterdam, Leiden University
Medical Center (LUMC)

FUNDED

TU Delft
University 100 %
FOM -
STW -
NWO Other -
Industry -
TNO -
GTI -
EU -
Scholarships -

START OF THE PROJECT

2010

INFORMATION

S Kenjeres
015 278 3649
S.Kenjeres@tudelft.nl

PROJECT AIM

One of the main problems of chemotherapy is often not the lack of efficient drugs, but the inability to precisely deliver and concentrate these drugs in affected areas. Failure to provide localized targeting results in an increase of toxic effects on neighboring organs and tissues. One promising method to accomplish precise targeting is magnetic drug delivery. Here, a drug is bound to a magnetic compound injected into the blood stream. The targeted areas are subjected to an external magnetic field that is able to affect the blood stream by reducing its flow rate. We believe that mathematical modeling and numerical simulations can significantly contribute to further advancements of this technique.

PROGRESS

We have developed a comprehensive mathematical model for simulations of blood-flow under the presence of strong non-uniform magnetic fields. The model consists of a set of Navier-Stokes equations accounting for the Lorentz and magnetization forces, and a simplified set of Maxwell's equations (Biot-Savart/Ampere's law) for treating the imposed magnetic fields. The model is then validated for different patient-specific geometries (including a carotid artery and brain vascular system). First simulations of aerosol distribution within a human upper airway system were performed.

DISSERTATIONS

-

SCIENTIFIC PUBLICATIONS

1. Kenjeres S. (2015), 'Keynote Lecture: Recent progress in modelling, simulations and experiments of transport phenomena in the patient-specific cardiovascular geometries', International Symposium on Rheology, 23-25 September 2014, Kobe, Japan, pp.1-6
2. S. Kenjereš and J. Tjin (2015), "Simulations of targeted delivery of magnetic drug aerosols in the human respiratory system", The 8th International Symposium on Turbulence, Heat and Mass Transfer, September 15-18, 2015, Sarajevo, Bosnia and Herzegovina, Eds. Hanjalic et al., Begell House Inc., pp.563-566.
3. J. Klip and S. Kenjeres (2015), "Recent Development in Modelling and Simulation of the WSS Dependent Multi-Solutal Mass Transfer within a Multi-Layered Arterial Wall", The 10th International Symposium on Biomechanics in Vascular Biology and Cardiovascular Disease, April 23-14, 2015, Rotterdam, The Netherlands.
4. Nemati M., Lozen G. B., van der Wekken N., van de Belt G., Urbach H. P., Bhattacharya N., Kenjeres S. (2015), "Application of full field optical studies for pulsatile flow in a carotid artery phantom", Biomedical Optics Express, Vol. 6 (10), pp. 4037-4050 (doi: 10.1364/BOE.6.004037)

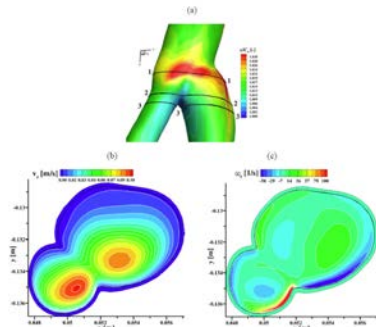

Modelling of the initial stage of atherosclerosis in the patient-specific carotid artery: contours of the non-dimensional LDL concentration at the carotid artery wall (-top), contours of the streamwise velocity and streamwise vorticity at characteristic location after bifurcation (2-2)

EXPERIMENTAL AND NUMERICAL INVESTIGATIONS OF TRANSITIONAL AND TURBULENT FLOWS OVER COMPLEX SURFACES WITH HEAT TRANSFER AND EMISSION OF PASSIVE SCALARS

PROJECT AIM

This is a joint project between Transport Phenomena Section, Department of Chemical Engineering at the TU Delft and the Laboratory for Transport Processes and Reactions of Prof. P. Rudolf von Rohr at ETH Zurich. The project addresses the combined experimental and numerical study of turbulent flows over complex surfaces with heat transfer and distribution of passive scalars. The final goal is to perform in parallel state-of-the-art experiments (stereo PIV, LIF, TLC) and numerical simulations (LES, hybrid RANS/LES, DES, RANS) for different wall configurations over a range of Reynolds numbers and intensities of the wall heat flux and scalar emissions.

PROGRESS

Experimental (PIV, LIF) and numerical studies (DNS, LES with dynamic Lagrangian SGS closure) performed for different configurations of narrow channels with a porous medium.

DISSERTATIONS

-

SCIENTIFIC PUBLICATIONS

1. Zenklusen A., Kenjeres S., Rudolf von Rohr P. (2014), "Vortex shedding in a highly porous structure", Chemical Engineering Science, Vol.106, pp.253-263 (doi: 10.1016/j.ces.2013.11.022).

PROJECT LEADERS

S Kenjeres, CR Kleijn

RESEARCH THEME

Complex dynamics of fluids

PARTICIPANTS

S. Kenjeres, P. Rudolf von Rohr
A. Zenklusen

COOPERATIONS

ETH Zürich, P. von Rohr

FUNDED

TU Delft, ETH Zurich, HPC-Europa 2

University 50 %

FOM -

STW -

NWO Other -

Industry -

TNO -

GTI -

EU 50 %

Scholarships -

START OF THE PROJECT

2012

INFORMATION

S Kenjeres

015 278 3649

S.Kenjeres@tudelft.nl

the wake structures and vortex shedding in dynamic LES simulation of the flow within a complex porous segment of a micro-reactor for which a detailed PIV and LIF measurements are performed at ETH.

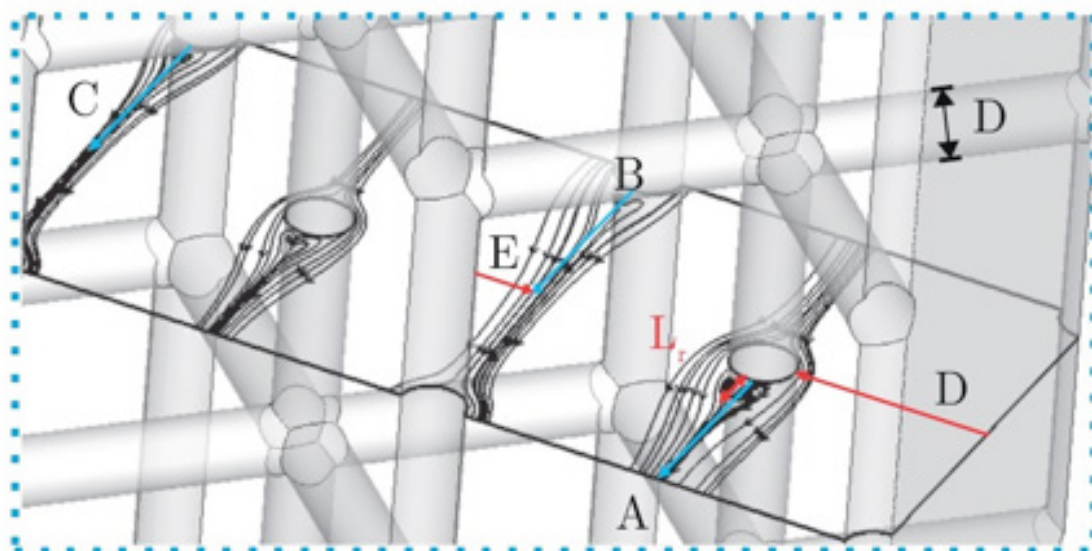

EXPERIMENTAL STUDY OF LOW AND MEDIUM PRANDTL NUMBER NATURAL AND MIXED CONVECTION FLOWS IN COARSE-GRAINED POROUS MEDIA

PROJECT LEADERS

CR Kleijn, RF Mudde, M Tummers
S Kenjeres

RESEARCH THEME

Complex dynamics of fluids

PARTICIPANTS

Iman Ataei Dadavi

COOPERATIONS

Tata Steel, M2i

FUNDED

STW, Tata Steel (through M2i)	
FOM	-
STW	50 %
NWO Other	-
Industry	100 %
TNO	-
GTI	-
EU	-
Scholarships	-

START OF THE PROJECT

2015

INFORMATION

M Chakkingal
M.Chakkingal@tudelft.nl

PROJECT AIM

The overall aim of this research project is to provide fundamental understanding of natural and mixed convection flows in coarse-grained porous media and to provide detailed experimental data to validate and improve developed simulation models. The interest for this project stems from its application in the blast furnace hearth in steel and iron making industries. To achieve this aim we will conduct PIV (Particle Image Velocimetry) and LCT (Liquid Crystal Thermography) measurements in water flows in a refractive index matched porous medium composed of a packed bed of spheres. We will also perform X-ray particle tracking and point temperature measurements in a liquid metal in order to gain a better understanding of low-Prandtl number thermal convection flow and heat transfer in porous media.

PROGRESS

In the very first stages of the project, we introduced water and hydrogel spheres as the pair of refractive index matched liquid and solid particles, which are well suited to PIV measurements of thermally driven flows in porous media. The applicability of Refractive Index Matching of hydrogel spheres and water in packed bed of spheres has been examined and confirmed.

Afterwards, time-resolved PIV measurements were conducted to obtain instantaneous and mean velocity vector fields of natural convection inside a water saturated packed bed of large particles, and the results were compared with the Rayleigh-Benard convection of pure water without porous structure in the same enclosure. The results show that the so called "mean wind" which is a large scale circulation with the diameter of the order of the cavity height and is an important feature of Rayleigh-Benard convection, is not present in the coarse-grained porous media convection and is totally disturbed as a result of interaction with the coarse porous structure. The instantaneous flow fields also show that the flow in porous media is hydrodynamically more stable, and that the velocity vectors and flow structures do not vary significantly with time. The other interesting observation is that the velocity fluctuations in the flow in porous structures are much smaller than that without porous media.

Preliminary Nusselt number measurements shows that the presence of the solid particles reduces the heat transport compared to an analogous pure fluid system without porous media.

DISSERTATIONS

-

SCIENTIFIC PUBLICATIONS

-

Mean velocity magnitude and vectors of the flow inside a randomly packed bed of spheres heated from below.

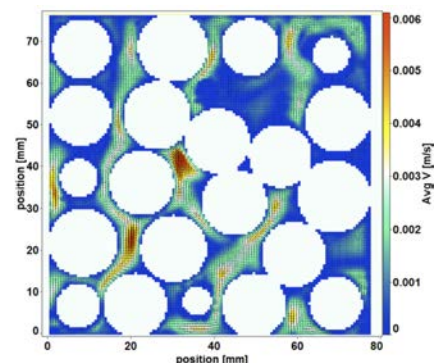

MODELING THE DYNAMIC BEHAVIOR OF REACTING COMPLEX FLUIDS IN NANOPORES: APPLICATION TO FISCHER-TROPSCH SYNTHESIS

PROJECT AIM

This project aims at understanding the physics of oil-water separation and their escape from a nanoporous network in a Fischer-Tropsch catalyst. Study of the separation physics requires integration of the transport phenomena and a thermodynamic description of the phase behavior. The objective of this project is to develop a multicomponent multiphase fluid flow solver that captures the dynamics of reacting fluids inside nanopores. In this project, we wish to study the effect of surface wall heterogeneity of the nanopore, in terms of reaction activity and wetting, on the demixing inside the nanopores in Fischer-Tropsch processes. These insights will help us optimize the process catalyst, improve catalyst life, and increased catalyst selectivity.

PROGRESS

We completed the development of the flow and reaction solver. The solver has been upgraded from an explicit method to a semi-implicit solver. We are currently applying this solver to a nanopore with significant convection to study the behavior of a droplet that forms at a hydrophilic catalytically active patch on the wall. We have identified numerical challenges associated with phase field modeling of this nanoscopic diffusion-convection-reaction system such as droplet dissolution and formulated guidelines to cope with the challenges. Our work furthermore shows a strong correlation between catalyst utilization and different physical parameters such as surface energy distribution, multiphase interface thickness etc. We also developed a preliminary multiphase-multicomponent framework and solver within the phase field framework and currently apply it to model the Fischer-Tropsch process in a nanopore.

DISSERTATIONS

-

SCIENTIFIC PUBLICATIONS

1. Pimpalgaonkar, H. G., van Steijn, V., Kreutzer, M. T., & Kleijn, C. R. (2016, June). Modeling and simulation of diffusion-convection-reaction in heterogeneous nanochannels using OpenFOAM. In INTERNATIONAL CONFERENCE OF NUMERICAL ANALYSIS AND APPLIED MATHEMATICS 2015 (ICNAAM 2015) (Vol. 1738, No. 1, p. 480056). AIP Publishing.-

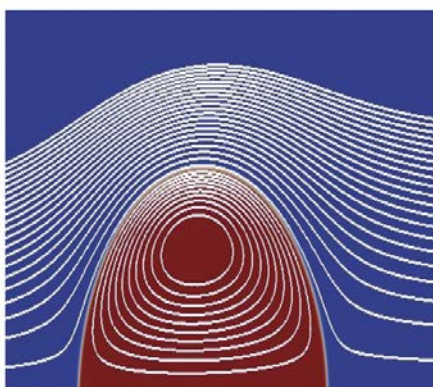
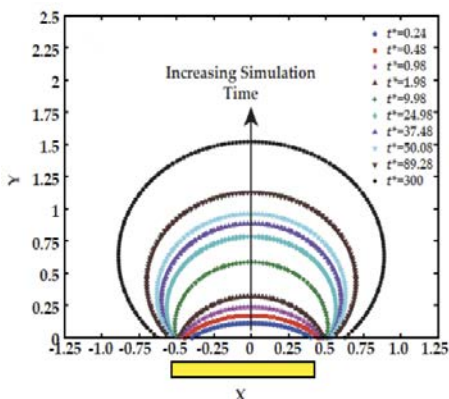

Left figure shows the growth of the droplet with time in diffusion-reaction simulations¹, figure on the right shows a streamline snapshot of a nanodroplet under shear (to be submitted)

PROJECT LEADERS

CR Kleijn, MT Kreutzer, V van Steijn

RESEARCH THEME

Multiphase Flows

PARTICIPANTS

H.G. Pimpalgaonkar (PhD Student)

COOPERATIONS

FOM, Shell

FUNDED

FOM, Shell

University

-

FOM 50 %

STW

-

NWO Other

-

Industry 50 %

TNO

-

GTI

-

EU

-

Scholarships

-

START OF THE PROJECT

2013

INFORMATION

CR Kleijn

015 278 2835

C.R.Kleijn@tudelft.nl

H Pimpalgaonkar

H.G.Pimpalgaonkar@tudelft.nl

015 278 7084

COALESCENCE AND MASS TRANSFER IN BUBBLY FLOWS

PROJECT LEADERS

R Mudde

RESEARCH THEME

Complex Structures of Fluids

PARTICIPANTS

Ir. Manas Mandalahalli (PhD/TUD)

COOPERATIONS

Prof. Hans Kuipers (TUE)

Prof. Detlef Lohse (UT)

Prof. Martin van Sint Annaland (TUE)

Dr. Ivo Roghair (TUE)

Dr. Bert Vreman (Akzo Nobel)

Dr. Peter Veenstra (Shell)

Dr. Patrick Wenmakers (DSM)

Dr. Christoph Dittrich (SABIC)

Ir. Dirk van der Plas (Tata Steel)

FUNDED

FOM-IPP

FOM 50 %

STW -

NWO Other -

Industry 50 %

TNO -

GTI -

EU -

Scholarships -

START OF THE PROJECT

2015

INFORMATION

M Mandalahalli

015 278 4387

m.m.mandalahalli@tudelft.nl

cheme.nl/TP

PROJECT AIM

The project is aimed at studying the fundamentals of mass transfer in bubbly flows, inspired by industrial applications. This involves understanding the interaction between local hydrodynamic forces and mass transfer and its implications on global transport process. Experimentally, focus is placed on developing and using minimally intrusive light and radiation based techniques to study flow and concentration profiles.

PROGRESS

First year of the PhD was mainly focused on literature survey, while defining research questions and an experimental plan. Initial experiments were carried out to understand the challenges involved in using two-phase Particle image velocimetry (PIV). Using fluorescent particles, the flow structure could be obtained for a pair of rising bubbles (figure below). With the newly acquired PIV setup, we will study the interaction of wakes of bubbles quantitatively. Simultaneously, first steps have been made towards developing X-ray particle tracking technique (XPTV) using tomographic reconstruction. With this technique we aim to study flow structure around dense microbubbles in an internal airlift column, aiding in better bubble column design.

DISSERTATIONS

-

SCIENTIFIC PUBLICATIONS

-

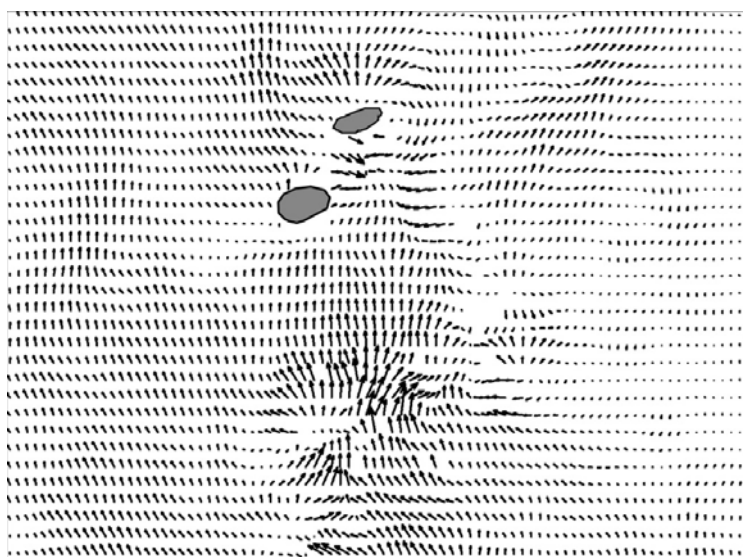

Flow structure around rising pair of bubble in water using PIV

DEVELOPMENT OF AN OIL-WATER SEPARATOR: TOWARDS APPLICATION

PROJECT AIM

It has been shown by Laurens van Campen that bulk separation of oil and water can be achieved using in-line axial swirl elements. Our industry partners have set the ambitious target of achieving ~ 2000 ppm oil in the water stream since this would make swirl separation technology competitive with the large settling tanks that are currently used. The industry partners would like to know to what extent the water stream can be purified so that the water can be disposed of in the field. To this end, separation efficiency measurements in two-phase flows are performed for water rich inlet conditions. In addition, the effect of the flow split on the flow field is investigated since this parameter has a very significant influence on the flow field and can be used as a control parameter in the field.

PROGRESS

The separation efficiency measurements have allowed us to identify certain promising inlet conditions that would allow for different routes to achieving pure water. It has been found that the interfacial tension of the oil in water plays an important role in determining the separation efficiency. We have also developed some simple scale-up laws to allow for our lab-scale results to be extrapolated to field conditions. Furthermore, we have measured the wall pressure profiles, the velocity field in the cyclone and we have estimated the pressure in the vortex core. The velocity field has been measured using stereoscopic-Particle Image Velocimetry (SPIV). These experiments are still underway and Ruiz Knobel, an Applied Physics MSc. candidate will report the final findings in his MSc. thesis. Due to confidentiality agreements, some of the figures below have been obscured.

DISSERTATIONS

-

SCIENTIFIC PUBLICATIONS

-

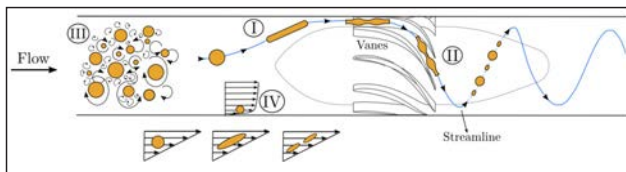

Droplet break-up mechanisms; scale-up takes these mechanisms into account.

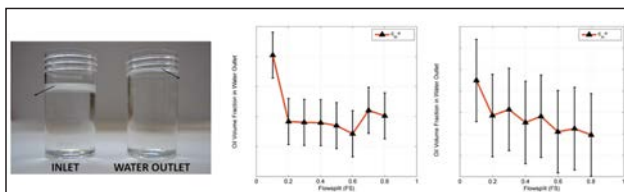

Sample from inlet and water outlet (left). Two-step strategy to achieve clean water (right).

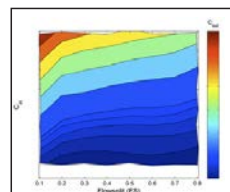

Performance envelope of an given swirl element for an inlet condition. Allows a sweet spot to be found for industrial application.

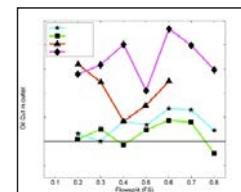

Comparison between the different swirl elements with significant performance differences.

PROJECTLEADERS

RF Mudde, HWM Hoeijmakers,
P Veenstra (Shell), J Bos (Frames)
M Plantenga (ISPT)

RESEARCHTHEME

Complex dynamics of fluids

PARTICIPANTS

Delft University of Technology
Dr.ir. Ashok (post-doc)
Prof. dr. R.F. Mudde
University of Twente
Dr. ir. Jacco Hospers (post-doc)
Prof. H.W.M. Hoeijmakers

COOPERATIONS

UT

FUNDED

Institute of Sustainable Process
Technology (Industry partners:
Frames and Shell)
University -
FOM -
STW -
NWO Other -
Industry 100 %
TNO -
GTI -
EU -
Scholarships -

START OF THE PROJECT

2014

INFORMATION

RF Mudde
015 278 2834
R.F.Mudde@TUDelft.NL
www.cheme.nl/tp

TIME-RESOLVED X-RAY TOMOGRAPHY APPLIED TO FLUIDIZED BEDS

PROJECT LEADERS

RF Mudde, JR van Ommen

RESEARCH THEME

Complex dynamics of fluids

PARTICIPANTS

Xiaogang Yang

COOPERATIONS

PSI (Switzerland)

FUNDED

CSC

FOM -

STW -

NWO Other -

Industry -

TNO -

GTI -

EU -

Scholarships 100 %

START OF THE PROJECT

2011

INFORMATION

RF Mudde

015 278 2834

r.f.mudde@tudelft.nl

PROJECT AIM

Study the hydrodynamics of various applications of fluidized beds using a fast X-ray tomographic system.

PROGRESS

We have tested algorithms to reconstruct limited data sets that we obtained from our X-ray set up. He have shown that the so-called Adaptive Genetic Algorithm (AGA) outperforms the traditional SART reconstruction technique in finding small objects, but is much slower. Our results led to a hybrid SART-AGA approach. Moreover, we have used our X-ray facility to investigate the dynamics of a spouted bed: a fluidized system in which a central gas jet is blown, creating a central spout. We estimated the stability of the spout size and position for various flow conditions. Moreover, we used our facility to study the influence of heat exchange tubes on the bubbles in a fluidized bed. Finally, a study was made to determine the influence of an intrusive optical probe on the fluidized bed hydrodynamics.

DISSERTATIONS

1. Yang, X., Gas jets in granular matter – observed by a high speed X-ray tomography system, PhD thesis, TU Delft, March 11, 2015.

SCIENTIFIC PUBLICATIONS

1. Yang, X., van Ommen, J. R., Schoormans, J., & Mudde, R. F. (2015). A hybrid tomographic reconstruction algorithm for high speed X-ray tomography. *Computer Physics Communications*, 196, 27-35.
2. Yang, X., van Ommen, J. R., & Mudde, R. F. (2015). Gas distribution of a downward micro-nozzle assisted fluidized bed of fine powder. *Chemical Engineering Journal*, 264, 945-953.
3. Maurer, S., Wagner, E. C., Schildhauer, T. J., van Ommen, J. R., Biollaz, S. M., & Mudde, R. F. (2015). X-ray measurements of bubble hold-up in fluidized beds with and without vertical internals. *International Journal of Multiphase Flow*, 74, 118-124.
4. Maurer, S., Wagner, E. C., van Ommen, J. R., Schildhauer, T. J., Teske, S. L., Biollaz, S. M., ... & Mudde, R. F. (2015). Influence of vertical internals on a bubbling fluidized bed characterized by X-ray tomography. *International Journal of Multiphase Flow*, 75, 237-249.
5. Maurer, S., Wagner, E. C., Schildhauer, T. J., van Ommen, J. R., Biollaz, S. M., & Mudde, R. F. (2015). X-ray measurements on the influence of optical probes on gas-solid fluidized beds. *International Journal of Multiphase Flow*, 74, 143-147.

HYDRODYNAMICS OF INDUSTRIAL FERMENTATION PROCESSES

PROJECT AIM

The metabolic response of organisms in a fermentor depends on their environment, determined by the hydrodynamics, which may be spatially heterogeneous. The aim is to develop a computational fluid/reaction dynamics model that captures this heterogeneity. The results will serve as an input for laboratory experiments designed to study organisms in an industrially relevant environment; which is very relevant for the design of industrial fermentors.

PROGRESS

The required minimum amount of particles to obtain an accurate concentration field has been studied, yielding a criterion based on mixing and reaction parameters. The proposed Fourier method to analyze particle tracks has been discarded in favor of a regime-based analysis method, allowing to quantify the frequency and amplitude of (concentration) variations experienced by organisms. First steps towards designing lab-scale experiments resembling large reactors were made. Further work towards gas-liquid simulations has been conducted, including use of population balance methods. A final line of work considers mixing in multi-impeller vessels; literature shows predicted mixing times in such vessels are too high, while single-impeller predictions are good. RANS & LES simulations towards the cause of this over-prediction have been initiated, experimental support is planned.

DISSERTATIONS

-

SCIENTIFIC PUBLICATIONS

-

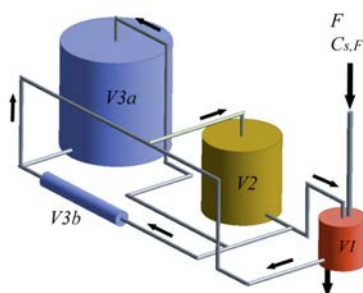
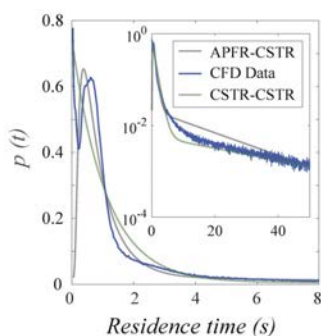

Left: Residence time distribution for micro-organisms under glucose starvation conditions (CFD) in a 55m³ reactor, and 2 lab-reactor strategies for experimental replication of this RTD. Right: design proposal for a lab-scale system mimicking the 55m³ reactor, including a glucose starvation, glucose limitation and glucose excess zone.

PROJECT LEADERS

R. Mudde

RESEARCH THEME

Mathematical and computational methods for fluid flow analysis

PARTICIPANTS

Ir. Cees Haringa (PhD/TUD)

COOPERATIONS

ECUST Shanghai

DSM

Neil Tang MSc. (PhD/ECUST)

Prof. Henk J. Noorman (TUD, DSM)

Prof. Ju Chu (ECUST)

Dr. Jianye Xia (ECUST)

Prof. Joseph J. Heijnen (TUD)

Dr. Walter M. van Gulik (TUD)

Prof. Matthias Reuss (Univ. Stuttgart)

Dr. Wouter van Winden (DSM)

Dr. Amit T. Deshmukh (DSM)

FUNDED

NWO/MoST-Hé, DSM

University -

FOM -

STW -

NWO Other 50 %

Industry 50 %

TNO -

GTI -

EU -

Scholarships -

START OF THE PROJECT

2013

INFORMATION

C. Haringa

015 278 7084

c.haringa@tudelft.nl

cheme.nl/TP

GAS PHASE DEPOSITION OF ALUMINUM OXIDE AT AMBIENT CONDITIONS

PROJECT LEADERS

MT Kreutzer, JR van Ommen,
GMH Meesters

RESEARCH THEME

Complex structures of fluids

PARTICIPANTS

Dr. ir. David Valdesueiro (PhD student)

COOPERATIONS

DSM Coating Resins, Zwolle (NL)
Optoelectronic Materials (TU Delft)
University of Surrey (UK)

FUNDED

Marie Curie Actions F7 Framework
DSM Coating Resins
FOM -
STW -
NWO Other -
Industry 25 %
TNO -
GTI -
EU 75 %
Scholarships -

START OF THE PROJECT

2011

INFORMATION

JR van Ommen
015 278 2133
j.r.vanommen@tudelft.nl
<http://cheme.nl/pppe>

PROJECT AIM

This project aims at the development of ultrathin gas phase coatings that can be applied to heat sensitive substrates, both flat or powders. These ultrathin coatings, ranging from 1 to 20 nm in thickness, can provide protection from external agents, such as oxygen or humidity, or activate the surface to enhance the properties of the substrate such as the catalytic activity. By operating the process at atmospheric pressure and room temperature, these coatings can be used to improve the performance of polymeric substrates or biological compounds.

PROGRESS

By using the coating technique atomic layer deposition (ALD), thin aluminum oxide films were deposited on titanium oxide nanoparticles at ambient conditions (25°C and 1bar) having comparable properties and growth rate as the process carried out at 170°C and <1mbar. This development facilitates the coating process, since working at atmospheric pressure requires less energy and equipment, while working at room temperature allows the use of heat sensitive coatings.

We deposited thin aluminum oxide films on PbSe (lead-selenide) quantum dot films in order to stabilize these materials, that can be used in solar cells, from oxidation in the environment. Additionally, we modified the surface finished of a powder coating paint by depositing a thin aluminum oxide films on the substrate. These results open the door of easy-to-process coating technique that can be applied to heat sensitive substrates.

DISSERTATIONS

1. Gas phase deposition of thin aluminium oxide films at ambient conditions, D. Valdesueiro, PhD thesis, defended on 4th November 2015.

SCIENTIFIC PUBLICATIONS

1. Gas-phase deposition of ultrathin aluminium oxide films on nanoparticles at ambient conditions, D. Valdesueiro, G.M.H. Meesters, M.T. Kreutzer, J.R. van Ommen, *Materials* 2015, 8(3), 1249-1263.

SIMULATING THE MESO-SCALE PROCESSES IN TWO-PHASE CHEMICAL REACTORS

PROJECT AIM

The aim of the project is to provide a numerical framework for simulating multi-phase catalytic chemical reactors using the Lattice Boltzmann (LB) method. The mesoscopic nature of the LB method allows for an efficient implementation of many relevant phenomena such as phase separation, mass and heat transfer, and catalytic surface chemistry. A large part of the project will deal with combining these implementations and validating the resulting framework using canonical cases from literature. The final part of the project will be to use the framework to analyse an existing chemical reactor on relevant issues such as the occurrence of hot-spot formation.

PROGRESS

The ongoing research has been on the LB implementation of a model which accounts for variable molecular masses in multi-component systems. A manuscript on the variation of the speed of sound in isothermal LBMs was not accepted by Phys. Rev. E and we are in the process of formatting the manuscript for submitting to Int. J. of Num. Methods. An extension to this work applied to species with varying molecular weights in the simulation of a catalytic channel will be submitted to Chem. Eng. Sc.

A student project on relating relevant multiphase macroscopic quantities such as surface tension and density ratios to LB simulation parameters has been completed. This project has given us a better understanding of the translation of real-world parameters into lattice Boltzmann parameters. Another student project on investigating the effects of spurious velocities on mass transfer has been completed as well. This student's work on stationary droplets will be combined with additional work on moving droplets and prepared for a publication.

A journal paper in cooperation with Ahad Zarghami on the assessment of interaction potentials in non-isothermal LBM multiphase systems has been accepted to Phys. Rev. E.

DISSERTATIONS

-

SCIENTIFIC PUBLICATIONS

1. Zarghami, Looije and Van den Akker, Assessment of interaction potential in simulating nonisothermal multiphase systems by means of lattice Boltzmann modeling, Phys. Rev. E 92 (2015)

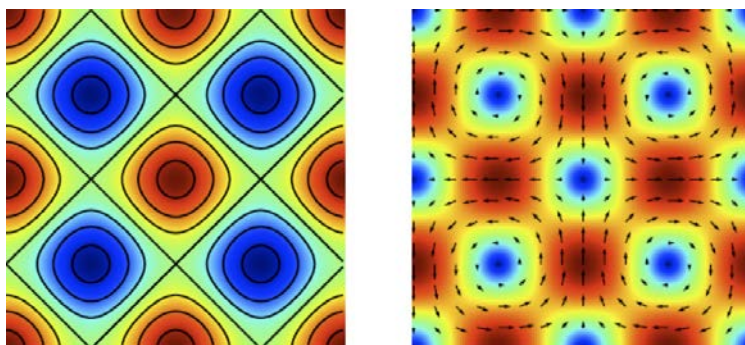

Figure 8. Initial conditions of a Taylor-Green Vortex: density (left), velocity (right).

PROJECTLEADERS

HEA van den Akker

RESEARCHTHEME

Mathematical and computational methods for fluid flow analysis

PARTICIPANTS

N Looije, JJJ Gillissen

COOPERATIONS

S Sundaresan (Princeton Uni.)

FUNDED

Shell Global Solutions, ISPT

University -

FOM -

STW -

NWO Other -

Industry 100 %

TNO -

GTI -

EU -

Scholarships -

START OF THE PROJECT

2011

INFORMATION

N Looije

N.Looije-1@tudelft.nl

0614975799

DECENTRALIZED WATER PURIFICATION USING SOLAR THERMAL ENERGY FOR ONE FAMILY IN THE DEVELOPING WORLD

PROJECT LEADERS

RF Mudde

RESEARCH THEME

Heat and mass transfer

PARTICIPANTS

Rajat Bhardwaj

COOPERATIONS

DrTen B.V.

FUNDED

DrTen B.V.

FOM -

STW -

NWO Other -

Industry 100 %

TNO -

GTI -

EU -

Scholarships -

START OF THE PROJECT

2011

INFORMATION

R Bhardwaj

06 34423607

R.bhardwaj@tudelft.nl

PROJECT AIM

To develop an affordable solar distillation system for water purification. The still should be used by the poor in third world countries and hence should rely on solar energy only, have no high tech parts and should be cheap.

PROGRESS

We have shown the use of an "air gap membrane distillation" unit which can be scaled up for the production of 2.5 – 3.5 l/day of drinking water. The membrane solar still showed consistent purification of high saline feed water containing NaCl (25% by weight) to a permeate with a concentration of < 500 mg/l for a period of 60 hours. Additionally, the still was also able to purify As (500 ppb), FI (50 ppm) and NO₃ (1000 ppm) to concentration levels below the guidelines values set by the WHO. We also tested the effect of coverage of the phobic material on the surface of the membrane. Results show that an increase in the percent concentration (by weight) of phobic additive from 5 % to 15 % increased the yield of the water by more than six times. The percent increase in the yield of water on further increase of the concentration of phobic additive was less significant. We have also demonstrated the effect of adding plastic channels as passive condenser on an inflatable solar still (Figure 1). The still has a basin area of 1.8 m². The tests were performed in lab conditions at different water temperatures. The production of water achieved from the still at a water temperature of 73 °C was 0.75 liter/hour. Furthermore, the production of water increased to more than 0.95 liter/hour with use of air flow over the passive condenser to mimic wind or with the use of a wet tissue on the passive condenser to mimic evaporation cooling. Further, we have shown important aspects of solar distillation which contribute to the practical application of solar stills. These cover re-mineralization of distilled water to the levels of total dissolved solids recommended by the WHO and increase in the production of water from solar still by decreasing the temperature of the condensation surface.

DISSERTATIONS

SCIENTIFIC PUBLICATIONS

1. R. Bhardwaj, M.V. ten Kortenaar, R.F. Mudde, 2015, Maximized production of water by increasing area of condensation surface for solar distillation, Applied Energy, 154, 480-490..

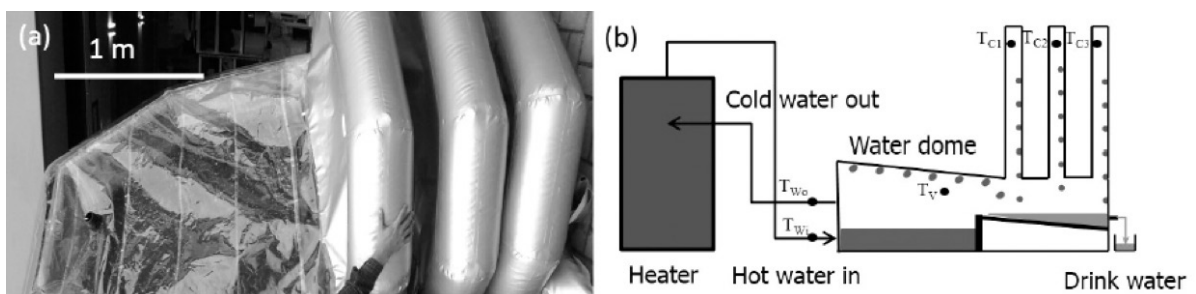

DNS OF EMULSIONS: MOBILE INTERFACES AND ADSORBED SURFACTANTS

PROJECT AIM

Coalescence and break-up of droplets and bubbles, interface mobility and surfactants are crucial to many industrial processes, from separation in oil & gas production to emulsion polymerization and foaming, to name a few. For predicting these processes, a sound description of the phenomena at the droplet and interfacial scale is required while at the same time, a theoretical description at the macro-scale is needed for development and optimizing of industrial scale processes - the two differ by several orders of magnitude. The current practice lacks fundamental rigor, making the scale-up and scale-down procedures unreliable. We shall develop a mesoscopic DNS framework using both the Volume of Fluid and Pseudo-Potential lattice Boltzmann methods to study droplet collisions under turbulent conditions in an emulsion system laden with surfactants, which shall help formulate more accurate coalescence and break-up models useful for macroscopic simulations.

PROGRESS

After validating the VOF solver in OpenFOAM, we incorporated a passive species transfer scheme for two component flow, relevant for the bulk transport of the surfactant. This species transfer was first validated for a purely diffusive case against correlations from literature for infinite composite media, and then for mass transfer from rising bubbles (in 2D) compared to experimental correlations. Further, a collaborative comparison between VOF (using OpenFOAM and FLUENT) and PP-Lattice Boltzmann is being performed to assess their relative strengths and weaknesses for generic multiphase flows.

DISSERTATIONS

-

SCIENTIFIC PUBLICATIONS

-

PROJECT LEADERS

S Kenjereš, HEA van den Akker,
RF Mudde

RESEARCH THEME

Mathematical and computational
methods for fluid flow analysis

PARTICIPANTS

Ir. Siddhartha Mukherjee

COOPERATIONS

ISPT

FUNDED

ISPT	100 %
FOM	-
STW	-
NWO Other	-
Industry	-
TNO	-
GTI	-
EU	-
Scholarships	-

START OF THE PROJECT

2015

INFORMATION

S Mukherjee
s.mukherjee@tudelft.nl

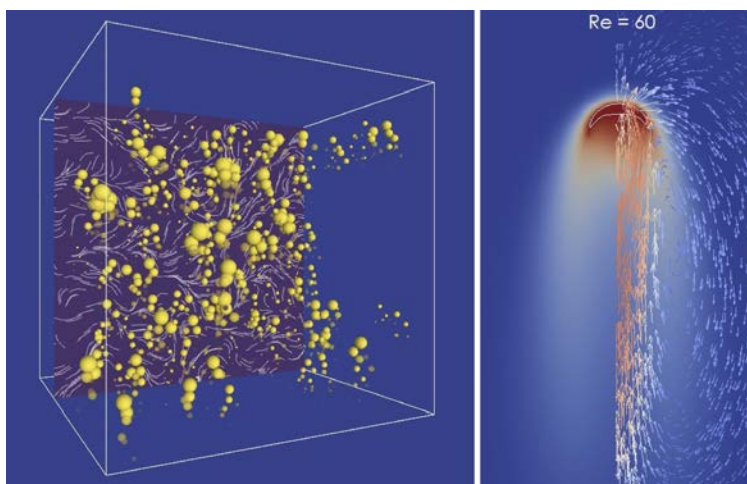

Left: Schematic of our proposed DNS system with droplets under turbulence;
Right: Snapshot of mass transfer from a single rising bubble (VOF)

MODELING AND SIMULATION OF GAS-LIQUID ANNULAR FLOW

PROJECT LEADERS

LM Portela

RESEARCH THEME

Complex dynamics of fluids

PARTICIPANTS

Galileu Oliveira
(Petrobras engineer)

COOPERATIONS

Petrobras

FUNDED

Petrobras
University -
FOM -
STW -
NWO Other -
Industry 100 %
TNO -
GTI -
EU -
Scholarships -

START OF THE PROJECT

2015

INFORMATION

LM Portela
06 20046078
l.portela@tudelft.nl

PROJECT AIM

Use advanced numerical simulation techniques, like DNS and LES, together with some modelling, to isolate the different mechanisms in gas-liquid annular flow, in order to get a better understanding of its dynamics. Use this understanding to develop simple engineering models.

PROGRESS

The project is a continuation of the Ph.D. work of Galileu Oliveira, who had to resume his activities as an engineer in Petrobras. He is now working part-time in the project. The dynamics of the interaction between the gas core and the liquid film was studied, using DNS to isolate different aspects. The results show that the interaction can be reasonably approximated using the concept of an "interfacial function" (an extension of the classical "wall function" concept).

DISSERTATIONS

-

SCIENTIFIC PUBLICATIONS

1. A. T. van Nimwegen, K. C. J. Schutte and L. M. Portela. Direct Numerical Simulation of turbulent flow in pipes with an arbitrary roughness topography using a combined momentum-mass source immersed boundary method. *Computers & Fluids*, vol. 108, pp. 92-106 (2015).

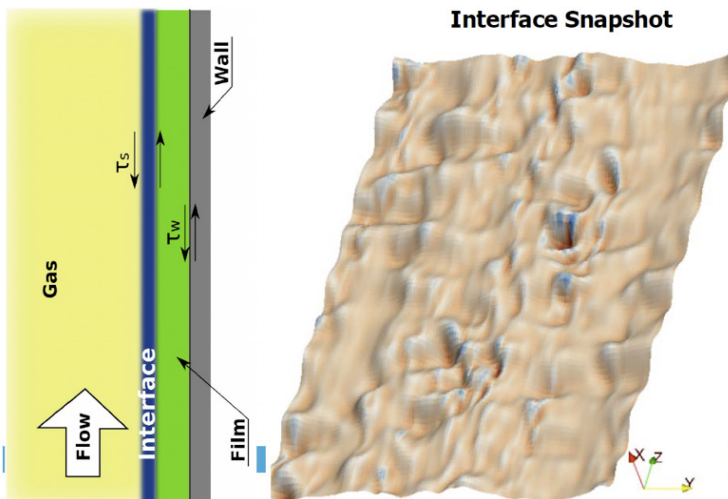

MODELING OF ASPHALTENE DEPOSITION IN PIPELINES

PROJECT AIM

Develop physically-based simple engineering models for the deposition of asphaltenes in pipelines.

PROGRESS

A simple quasi-1D model that takes into account the main mechanisms associated with asphaltene agglomeration and breakup, and with the asphaltene deposition at the wall was developed. In essence, the model is a simplified population-balance model: it considers only three classes of asphaltene and divides the cross-section of the pipe in a core region and a near-wall region. The model was used to study the evolution of the layer of asphaltene deposits at the wall, in quasi-1D pipe flows (i.e. with a slowly varying cross-section).

DISSERTATIONS

-

SCIENTIFIC PUBLICATIONS

-

PROJECT LEADERS

LM Portela

RESEARCH THEME

Mathematical and computational methods for fluid flow analysis

PARTICIPANTS

Marisa Bazzi

COOPERATIONS

Petrobras

FUNDED

University	-
FOM	-
STW	-
NWO Other	-
Industry	-
TNO	-
GTI	-
EU	-
Scholarships	100 %

START OF THE PROJECT

2015

INFORMATION

LM Portela

06 20046078

l.portela@tudelft.nl

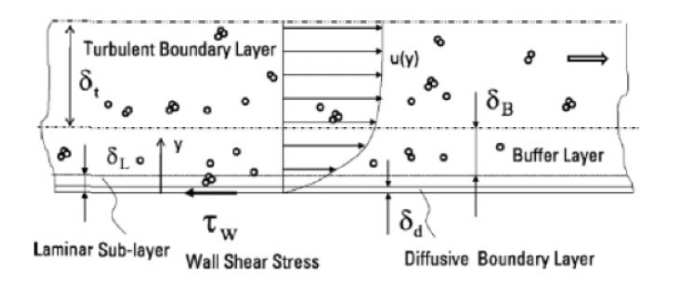

PROJECT LEADERS

LM Portela, C Schaerer,
N Mangiavachi

RESEARCH THEME

Mathematical and computational
methods for fluid flow analysis

PARTICIPANTS

H Shin

COOPERATIONS

State University of Rio de Janeiro
National University of Asuncion

FUNDED

University	-
FOM	-
STW	-
NWO Other	-
Industry	-
TNO	-
GTI	-
EU	-
Scholarships	100 %

START OF THE PROJECT

2015

INFORMATION

LM Portela
06 20046078
l.portela@tudelft.nl

PROJECT AIM

Use sophisticated numerical simulation techniques, like DNS and LES, to improve the modelling and simulation of sediment transport using simpler engineering simulation tools (like two-fluid models and simple quasi-1D models)

PROGRESS

Point-particle DNS simulations were performed in order to determine several parameters used in two-fluid simulations of sediment transport (in the figure is shown the particle Schmidt number)

DISSERTATIONS

-

SCIENTIFIC PUBLICATIONS

-

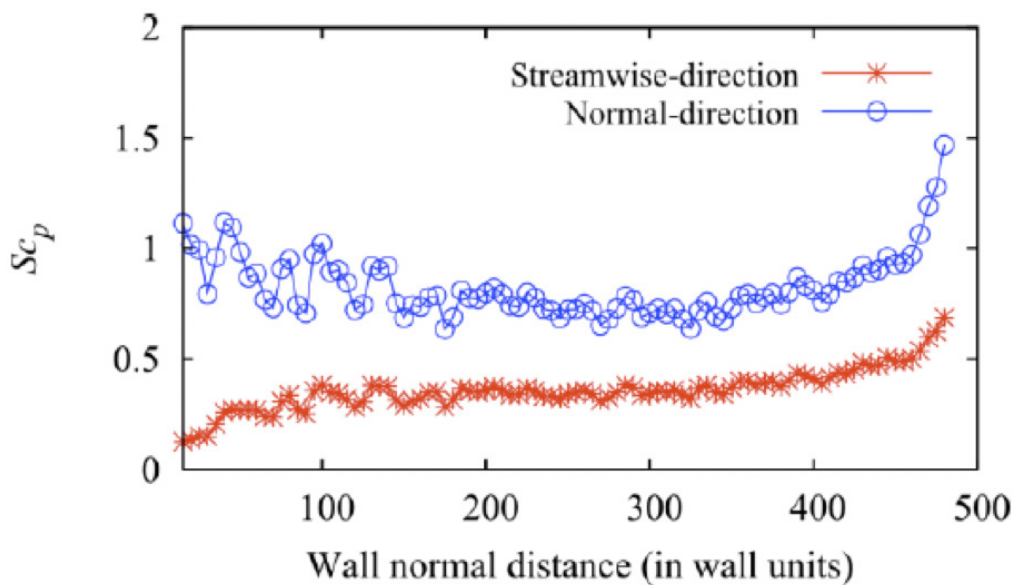





Prof.dr.ir. MT Kreutzer



Prof.dr.ir. R van Ommen

The Product and Process Engineering (PPE) of the ChemE department of TU Delft views chemical engineering as an expanding field full of opportunities to create devices, processes and products. With expertise in reaction engineering, fluid mechanics and transport phenomena, we create solutions for soft-matter, nanotechnology, energy and lab-on-chip applications, often together with chemistry, physics and life-science groups. For us, engineering implies out-of-the-box thinking and design, from a sound basis in natural sciences with mathematics rigor. We are interested both in computational approaches and experimental work.

An important part of our work – led by Michiel Kreutzer – is related to the flow of droplets and bubbles in microchannels, with the aim of doing fun chemistry inside or outside those drops and bubbles. Each droplet can be seen as a miniaturized reactor that moves through a network on a chip as would a test tube through a chemistry lab. These flows are laminar, but the free interfaces bring in nonlinearities and instabilities, often driven by surface tension. Much of this work is done in cooperation with the group of prof. Chris Kleijn. There are lots of interesting chemistries that we deal with, ranging from catalysis to immiscible polymers.

Volkert van Steijn explores the use of aqueous polymer solutions to form droplets in an environment free of organic solvents and surfactants. Such droplets offer great potential for biomedical applications as they are fully biocompatible. In addition, he investigates the possibilities of using microfluidic devices for cell cultures.

Pouyan Boukany uses nanofluidics-based devices for providing quantitative insights into the fundamental mechanism of drug delivery, disease treatment, gene therapy and response of individual cells to therapeutic/biomolecular reagents. In addition, he aims to understand the molecular dynamics of complex fluids using DNA as a model and advanced visualization techniques.

Ruud van Ommen is devoting an important part of his research efforts to dense gas-solid flows, where the solid phase consists of nanoparticles. In these systems, the nanoparticles cluster to form large, high-porosity agglomerates with fascinating interactions and flow properties. The aim is to chemically coat all individual nanoparticles in these agglomerates. He also studies gas-solid fluidized beds and three-phase systems with micron-sized particles, especially monitoring and structuring of these systems.

ELUCIDATING THE PHYSICS OF NANOPARTICLE INTERACTION AND CLUSTER DYNAMICS

PROJECT AIM

The aim is to investigate the interaction between individual nanoparticles, simple agglomerates and complex agglomerates in fluidized beds. There will be a focus on the effect of surface modification on the previously studied interactions, and the development of techniques for efficient use of nanopowders from the acquired knowledge.

PROGRESS

Experimental and theoretical analysis of the fluidized agglomerate structure, focused on the fractal dimension, aggregate, and agglomerate size distributions based on videos of free falling agglomerates in a fluidized bed as well as other size measurement techniques. The adhesion forces between individual nanoparticles inside agglomerates was measured for different surface modifications and materials gave fundamental insight into the nature of these forces. Furthermore, the elasticity of such agglomerates was investigated using atomic force microscopy

DISSERTATIONS

-

SCIENTIFIC PUBLICATIONS

-

PROJECT LEADERS

JR van Ommen, MT Kreutzer

RESEARCH THEME

Complex structures of fluids

PARTICIPANTS

Andrea Fabre, Samir Salameh

COOPERATIONS

Max Planck Institute for Polymer Research, Mainz, Germany
Nanostructured Films and Particles group, University of Zaragoza, Spain

FUNDED

European Research Council (ERC)

University	-
FOM	-
STW	-
NWO Other	-
Industry	-
TNO	-
GTI	-
EU	100 %
Scholarships	-

START OF THE PROJECT

2012

INFORMATION

RF van Ommen

J.R.vanOmmen@tudelft.nl

015 278 2133

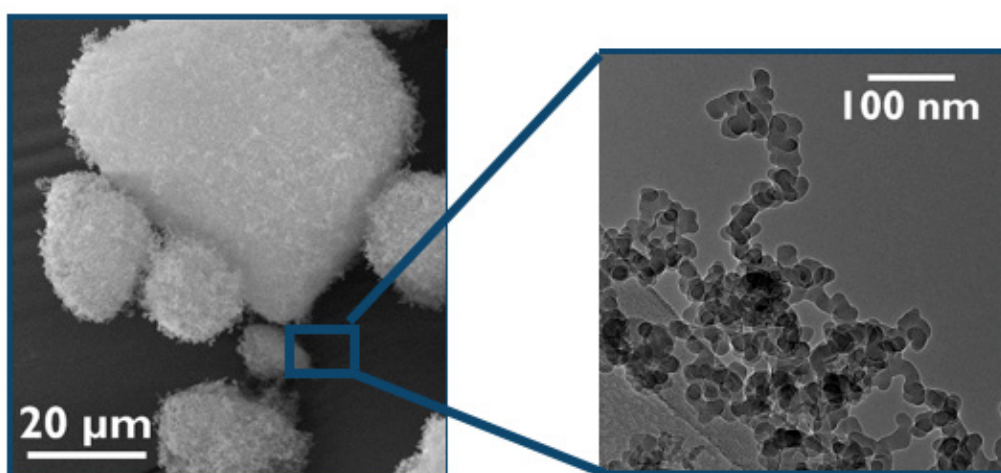

Immersed sphere (left) and surface book-keeping method (right)

NUMERICAL MODELLING OF 4D LEFT VENTRICULAR BLOOD FLOW USING COMPUTED TOMOGRAPHY IMAGING AND COMPUTATIONAL FLUID DYNAMICS

PROJECT LEADERS

SS Khalafvand, S Kenjeres

RESEARCH THEME

Complex dynamics of fluids

PARTICIPANTS

Dr. S.S.Khalafvand

Dr. S. Kenjeres

COOPERATIONS

ERASMUS Medical Center
Rotterdam, Leiden University
Medical Center (LUMC)

FUNDED

TU Delft, ZonMw: The Netherlands
Organisation for Health Research
and Development
University -
FOM -
STW -
NWO Other -
Industry -
TNO -
GTI -
EU -
Scholarships -

START OF THE PROJECT

2015

INFORMATION

S.S.Khalafvand@tudelft.nl

S.Kenjeres@tudelft.nl

PROJECT AIM

This study is aimed to quantify the characteristics of flow patterns in left ventricle (LV) via Computational Fluid Dynamics (CFD) and an Active Shape Model (ASM) derived from 4-D Computed Tomography (CT) images for 151 patients. Five characteristic 4D shape sets were generated from ASM model: the mean shape, and mode variations of +3 and -3 standard deviations (SD) along the first and second principal component of shape variation in the population. The vortex development pattern during cardiac cycle is investigated through these 5 shapes.

PROGRESS

We have reconstructed the LV geometry for five shapes. For each segmented geometry, separate unstructured grids consisting of tetrahedral cells were generated. The time step resolution of CT data was not fine enough for CFD simulation. Thus intermediate geometries were needed to volume smoothly passed through time steps. For solving the fluid flow domain with finite volume method, the Arbitrary Lagrangian-Eulerian (ALE) formulation of Navier-Stokes was used. The results are analyzed and compared for five characteristics shapes.

DISSERTATIONS

-

SCIENTIFIC PUBLICATIONS

-

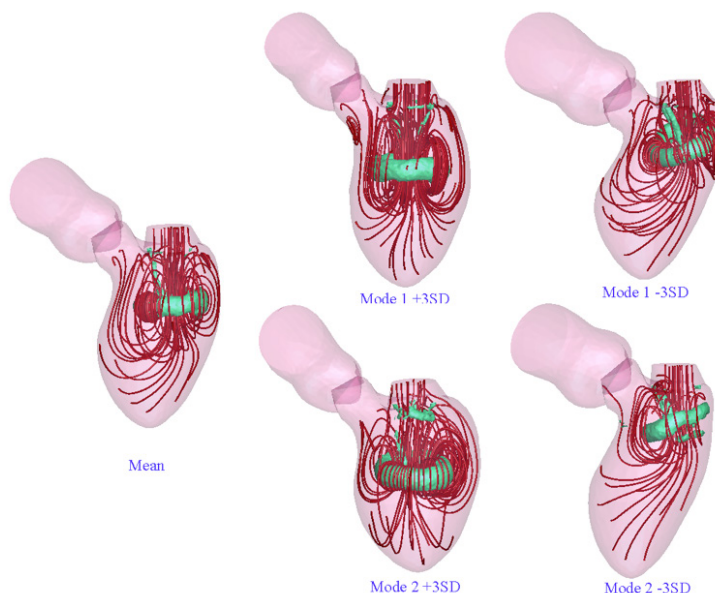

Figure: 3D vortex structure visualized by iso-surface of Q-criterion vortex identification and streamlines during slow filling of diastole in LV for 5 Characteristics shapes of the left ventricle

STUDY OF LOW PRANDTL NUMBER HEAT TRANSFER IN THE E-SCAPE LIQUID METAL POOL

PROJECT AIM

The aim of the project is to provide a fundamental understanding of, and experimentally validated models for, the turbulence and heat transfer in pool type fast reactors cooled by liquid metals. These insights and models will make it possible to develop a reliable Computational Fluid Dynamics (CFD) tool for industrial use (MYRRHA project).

PROGRESS

We have started with a detailed bibliographic research about the advanced fluid dynamics and the state-of-the-art turbulence models implemented in the open-source CFD code OpenFOAM. The Reynolds Averaged Navier-Stokes (RANS) and Large Eddy Simulation (LES) methods have been studied and applied to different wall and free shear flows in order to achieve a good command of the simulating and post-processing tools and understand the relevance of the most important computational and physical parameters. The most recent achievements concern the geometries and flows that could be experimentally tested. Different Prandtl numbers have been set in order to verify that the Reynolds analogy is not applicable to liquid metals.

DISSERTATIONS

-

SCIENTIFIC PUBLICATIONS

-

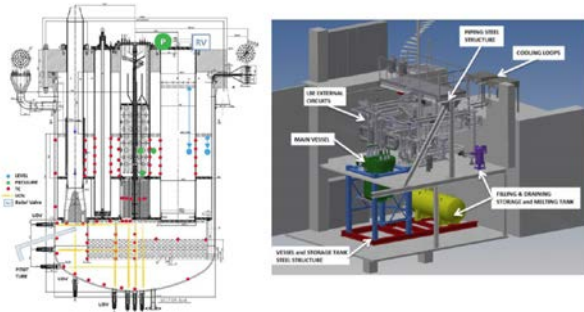

E-SCAPE main vessel (left) and E-SCAPE installation (right) - SCK•CEN

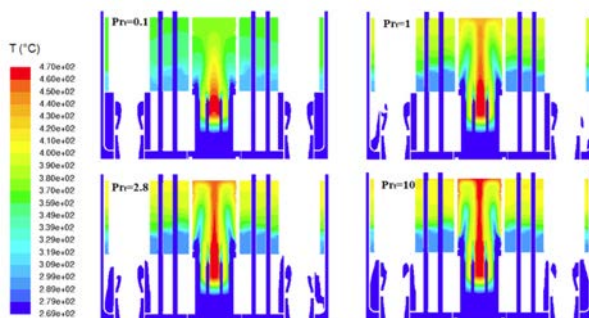

OpenFOAM simulation of the Upper Plenum of MYRRHA version 1.2 varying the turbulent Prandtl number - VKI

PROJECT LEADERS

C Kleijn, S Kenjereš, K Van Tichelen

RESEARCH THEME

Complex dynamics of fluids

PARTICIPANTS

Ir. Edoardo Cascioli

COOPERATIONS

SCK•CEN

VKI

FUNDED

SCK•CEN 100 %

University -

FOM -

STW -

NWO Other -

Industry -

TNO -

GTI -

EU -

Scholarships -

START OF THE PROJECT

2015

INFORMATION

E Cascioli

e.cascioli@tudelft.nl

+39360550029

NUMERICAL STUDY OF HEAT TRANSFER ENHANCEMENT DUE TO BOILING IN RAYLEIGH-BÉNARD CONVECTION.

PROJECT LEADERS

CR Kleijn, S Kenjereš

RESEARCH THEME

Complex dynamics of fluids

PARTICIPANTS

Ir. Kevin van As

COOPERATIONS

-

FUNDED

University -
FOM -
STW -
NWO Other 100 %
Industry -
TNO -
GTI -
EU -
Scholarships -

START OF THE PROJECT

2015

INFORMATION

K van As
K.vanAs@tudelft.nl
06 49622049

PROJECT AIM

The aim of the project is to provide a fundamental understanding of the influence of boiling on heat transfer in Rayleigh-Bénard Convection. This matter has only recently been studied by two independent groups. Lakkaraju et al. (2011-2014) have treated bubbles as point particles and neglected nucleate boiling. They have found a significant heat transfer enhancement due to the presence of the bubbles, in addition to a reduced intermittency. Biferale et al. (2012) have performed Lattice-Boltzmann simulations and found a significantly lower heat transfer enhancement and the opposite effect on intermittency: an enhancement. We wish to address this conflict in literature.

PROGRESS

The project started in September 2015. The first year was mostly spent on literature study and project definition. We will computationally study Rayleigh-Bénard convection with boiling, as there are clear discrepancies in literature on this matter on which we wish to shed light.

As preliminary results, some classical Rayleigh-Bénard convection simulations have been performed, and we have looked at some algorithms to simulate phase change. The next challenge will be to bring everything together in order to simulate boiling Rayleigh-Bénard convection. The main challenge to overcome is the fact that the combination of the two results in a challenging multi-scale physics problem.

DISSERTATIONS

-

SCIENTIFIC PUBLICATIONS

-

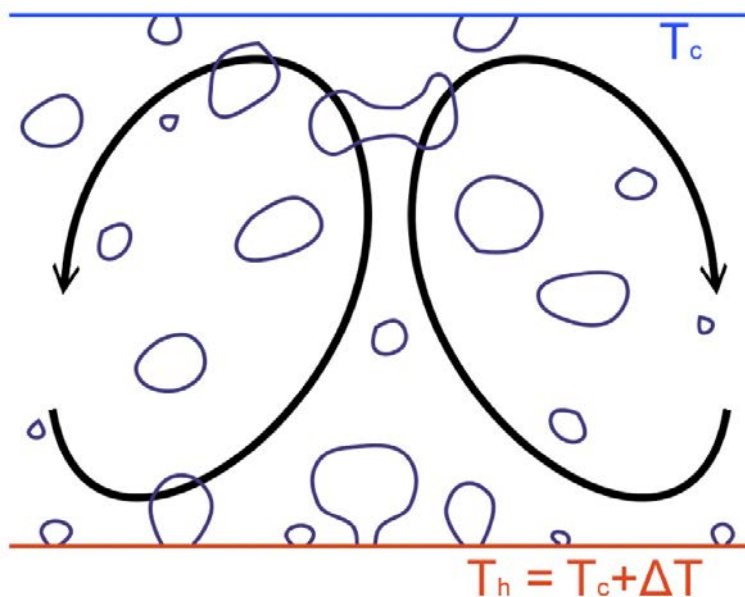

SIMULATION OF AGGLOMERATION AND COATING OF NANOPARTICLES IN A FLUIDIZED BED

PROJECT AIM

Coated nanoparticles have many potential applications, and we wish to produce large quantities of such particles by using Atomic Layer Deposition (ALD) in a fluidized bed reactor. However, due to the inter-particle cohesive forces, the nanoparticles form agglomerates in the fluidized bed, which influences the coating process. Our aim is to study the influence of the operating conditions and agglomerate structures on the overall coating time, and thus achieve guidelines for an efficient utilization of precursors and process optimization.

PROGRESS

Nanoparticle agglomerates of given fractal dimensions D_f are numerically constructed from up to 2048 equally sized spherical nanoparticles. Due to the small pore sizes, the gas in such an agglomerate is rarefied. Direct Simulation Monte Carlo (DSMC) is used to simulate the behavior of the inert and reactive gas molecules and their interaction with the nanoparticle surfaces.

First, we simulated non self-limiting first order surface coating reactions on the nanoparticle surfaces. We proposed a non-dimensional number characterizing the overall reaction rate. For a fixed value of this number, we found a power law scaling of the overall reaction rate with the size of the agglomerate.

Second, we simulated self-limiting first order surface coating reactions of the ALD type on the nanoparticle surfaces. Figure 1 shows a partially coated agglomerate from the simulation. We studied the overall coating time for agglomerates as a function of operating pressure, fractal dimension and agglomerate size. We also developed an analytic model, which predicts that the overall coating time scales with the number of particles in the agglomerate to the power $(2D_f - 4)/2$, in excellent agreement with our simulation results.

DISSERTATIONS

-

SCIENTIFIC PUBLICATIONS

-

PROJECTLEADERS

CR Kleijn, JR van Ommen

RESEARCHTHEME

Complex dynamics of fluids

PARTICIPANTS

Wenjie Jin

COOPERATIONS

-

FUNDED

University	-
FOM	-
STW	-
NWO Other	-
Industry	-
TNO	-
GTI	-
EU	-
Scholarships	-
NanonextNL	100 %

START OF THE PROJECT

2012

INFORMATION

JR van Ommen
015 278 2133
J.R.vanOmmen@tudelft.nl
<http://cheme.nl/ppe/people/vanommen.shtml>

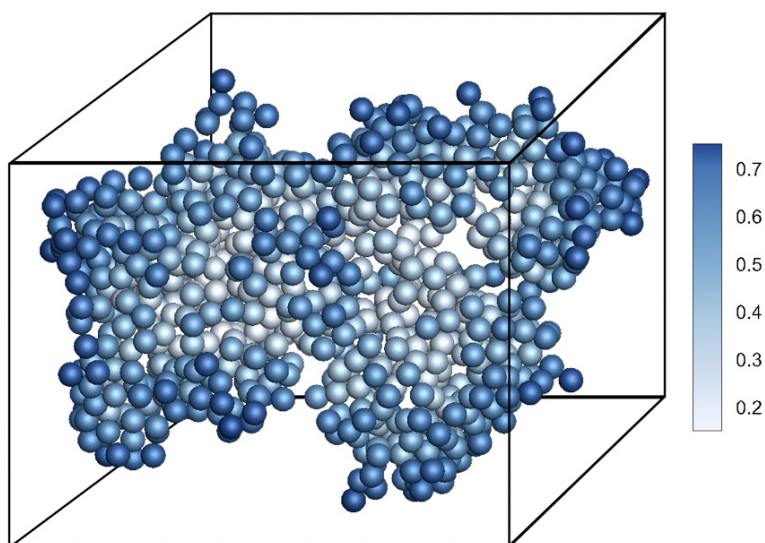

Surface coverage of each nanoparticle in an agglomerate.

DYNAMICS OF THIN FILMS UNDER THE INFLUENCE OF THERMAL FLUCTUATIONS

PROJECT LEADERS

CR Kleijn, MT Kreutzer, V van Steijn

RESEARCH THEME

Mathematical and computational methods for fluid flow analysis

PARTICIPANTS

M.S. Shah (PhD Student)

COOPERATIONS

ISPT/NWO

FUNDED

ISPT/NWO

University -

FOM -

STW -

NWO Other -

Industry 100 %

TNO -

GTI -

EU -

Scholarships -

START OF THE PROJECT

-

INFORMATION

CR Kleijn

015 278 2835

C.R.Kleijn@tudelft.nl

M Shah

0617368212

m.s.shah@tudelft.nl

PROJECT AIM

In this project, we aim to understand the role of thermal fluctuations in the dynamics of the thin film evolution in emulsion droplets. Using stochastic simulations, we investigate the effect of thermal fluctuations at the interface of emulsion droplets on the rupture time of the thin liquid films between the two droplets. Thermal fluctuations have been shown to influence thin film dynamics, but their role in the thinning of the film between emulsion droplets is largely unexplored. An important step forward from the existing studies is to include the curvature, corresponding to the Plateau border, in the description of these thin liquid films. These insights will help us control the stability of emulsions in food products to prolong the texture and the flavor of the products.

PROGRESS

We started with a validation of the stochastic thin film model by considering thin film dewetting as was done in earlier work by Grun and co-workers. Both deterministic and stochastic codes were validated data from literature. It can be seen from the figure 1, that the dewetting time decreases by a factor of 5 when thermal fluctuations are accounted for in the model. Currently, the stochastic thin film dewetting solver is explicit in nature and we are working towards making it implicit in order to allow us for a speed-up in the simulation time. Alongside working towards the validation of existing studies, we have developed the research questions that will be worked upon over the coming three years of the project. The answer to these questions will aim to fill the gap in the literature to reveal the role of thermal fluctuations in the thin film rupture in the context of two emulsion droplets.

DISSERTATIONS

-

SCIENTIFIC PUBLICATIONS

-

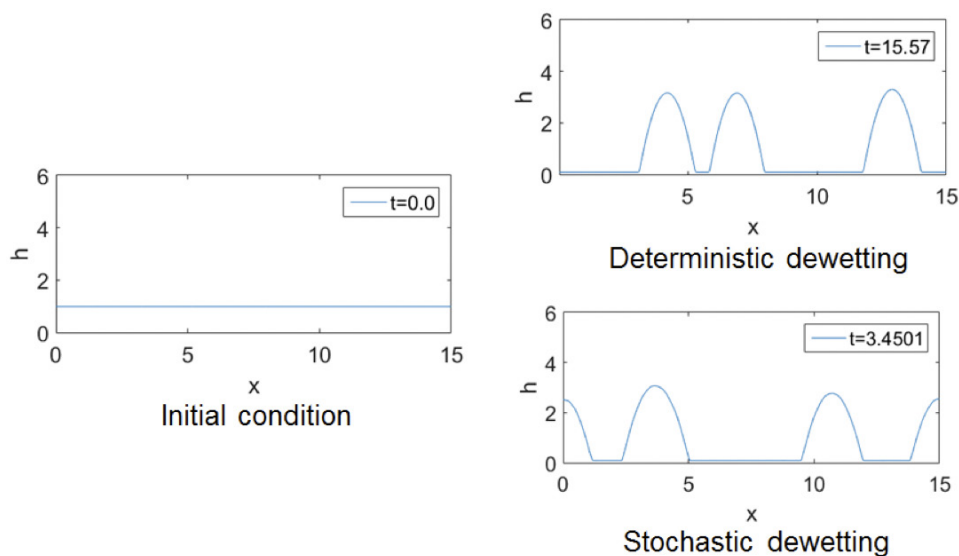

On the left, a nearly flat film is shown. Under the fluctuation-free (deterministic) evolution of the film, dewetting occurs at (a non-dimensional) time of ~ 15.5 units, whereas when thermal fluctuations are accounted for, dewetting occurs at ~ 3.5 units.





Prof.dr.ir. ThJJ van der Hagen

MISSION

The reactor physics department contributes to the development of sustainable nuclear energy such that it can play a major role in the global energy production. To this end, we focus on new and innovative nuclear reactors with improved efficiency, a high degree of safety, flexibility, and with a reduced waste production.

RESEARCH

Research in the department can be divided into three categories:

1. Thermal Hydraulics of Nuclear Reactors
 - ♦ Experimental research on stability of natural circulation Boiling Water Reactors with enhanced safety features.
 - ♦ Numerical analyses of thermal-hydraulic phenomena in new reactors like the SBWR and others. This also includes method and code development.
 - ♦ Thermo-Siphon research.
2. Reactor Physics Analysis of New Reactor Designs
 - ♦ VHTR: Design and analysis of a gas-cooled Very High Temperature Reactor for hydrogen production. Focus on core design and safety/transient analysis.
 - ♦ GCFR: Design and analysis of a Gas-Cooled Fast Reactor with a self-generating core and reduced waste production.
 - ♦ ADS: Dynamics analysis and development of reactivity measuring methods for Accelerator Driven Systems.
 - ♦ MSR: Design and Analysis of a Molten Salt Reactor with a high-conversion and/or breeding fuel cycle. Focus on core design, fuel cycle analysis, and dynamics and safety analyses.
 - ♦ Exotic designs, like the Fluidized Bed Reactor with a fast neutron spectrum, the CANDLE burnup reactor, and reactors for new applications.
3. Methods and Codes for Reactor Physics and Particle Transport
 - ♦ Development and application of electron-photon-neutron particle transport, possibly coupled to other codes like CFD.
 - ♦ Development and application of Monte Carlo transport methods possibly coupled to other codes like deterministic transport codes, and CFD.
 - ♦ Development and application of new reactor physics methods, like - mode calculations, coupled time-dependent neutronics and thermal-hydraulics, etc.
 - ♦ Development of methods to reduce leakage of nuclides from a geological disposal site.

LDA AND PIV MEASUREMENTS OF CROSSFLOW AND FLOW-INDUCED VIBRATIONS ON HEXAGONAL 7-RODS BUNDLE FACILITY

PROJECT AIM

Design and construction of two hexagonal 7-rods bundle facilities: one with wire wrapped around the rods, the other with the central rod able to vibrate under the influence of turbulence from the water flow or externally triggered. Experimental analysis is focused on crossflow across the gap between the cylinders, observation of the swirling structures that will be forming and evaluation of vibration frequencies. The experiments will be carried out with LDA and, possibly, with PIV systems.

PROGRESS

A preliminary measurement campaign is being conducted in a smaller test facility (CAMEL) by means of LDA system. Investigation of interaction between laser light and FEP polymer (RIM material) constituting part of the design; study of the turbulence field and presence of regular (coherent) flow patterns.

Design of two 7-rods hexagonal bundle facilities resembling a LMFR fuel assembly to study respectively the effect on the flow of the spacing wire wrapped around them and flow-induced and externally-induced vibrations on the central rod of such a bundle.

DISSERTATIONS

-

SCIENTIFIC PUBLICATIONS

1

PROJECT LEADERS

M Rohde

RESEARCH THEME

Complex structures of fluids

PARTICIPANTS

F Bertocchi, M Rohde,
JL Kloosterman

COOPERATIONS

SESAME project (H2020)

FUNDED

EU	
University	-
FOM	-
STW	-
NWO Other	-
Industry	-
TNO	-
GTI	-
EU	100 %
Scholarships	-

START OF THE PROJECT

2015

INFORMATION

F Bertocchi
015 278 4182
F.Bertocchi@tudelft.nl

NUMERICAL STUDY OF HEAT TRANSFER IN SUPERCRITICAL FLUIDS WITH A DISCONTINUOUS GALERKIN METHOD

PROJECT LEADERS

M Rohde, D Lathouwers

RESEARCH THEME

Mathematical and computational methods for fluid flow analysis

PARTICIPANTS

A Hennink

COOPERATIONS

-

FUNDED

TU Delft	
University	100 %
FOM	-
STW	-
NWO Other	-
Industry	-
TNO	-
GTI	-
EU	-
Scholarships	-

START OF THE PROJECT

2015

INFORMATION

A Hennink
a.hennink@tudelft.nl
<http://www.sco2-hero.eu/>

PROJECT AIM

My project is connected to the European sCO₂-HeRo project, which attempts to design a heat exchanger that is based on supercritical CO₂. Heat transfer in supercritical fluids is difficult to calculate. The goal of my PhD is to develop a discontinuous Galerkin method for this, and to investigate it in connection to supercritical CO₂. I will do calculations for the sCO₂-HeRo heat exchanger.

PROGRESS

I'm in the first year of my PhD project, and spent a lot of time on reading and catching up with the literature. I attended several courses and lecture series, both in the Netherlands and abroad. I worked on the in-house computer code that implements the numerical method, and investigate possibilities for parallelization. There is not much scientifically interesting progress yet.

DISSERTATIONS

-

SCIENTIFIC PUBLICATIONS

-

THREE-DIMENSIONAL, MULTI-PHYSICS SIMULATION OF A MOLTEN SALT FAST REACTOR

PROJECT AIM

The goal of the PhD research (part of the European SAMOFAR project) is to verify the safe operations of the Gen. IV MSFR during accident scenarios. To simulate them, advanced 3D multi-physics models must be developed, taking into account the physics of radiation transport, fluid flow (turbulent) and heat transfer specific for this reactor. The high-order Discontinuous Galerkin Finite Element numerical method is used to consistently improve the accuracy of simulations. Advanced uncertainties quantification schemes (polynomial chaos expansion and fully coupled multi-physics adjoint sensitivity analysis) will be used to analyze the outcomes of simulations and investigate the influence of uncertainties.

PROGRESS

Development and testing of the in-house code which solves the Navier-Stokes equations based on the Discontinuous Galerkin FEM discretization. Implementation of k-epsilon and k-omega RANS turbulence models.

Lot of time spent in literature study and attendance of several courses (both MSc and PhD level), being in the first year of the PhD.

DISSERTATIONS

-

SCIENTIFIC PUBLICATIONS

-

PROJECT LEADERS

D Lathouwers, M Rohde

RESEARCH THEME

Mathematical and computational methods for fluid flow analysis

PARTICIPANTS

M Tiberga, D Lathouwers, M Rohde, JL Kloosterman

COOPERATIONS

SAMOFAR (Horizon 2020).

FUNDED

EU	
University	-
FOM	-
STW	-
NWO Other	-
Industry	-
TNO	-
GTI	-
EU	100 %
Scholarships	-

START OF THE PROJECT

2015

INFORMATION

M Tiberga
015 278 6618
m.tiberga@tudelft.nl
<http://samofar.eu/>

DEVELOPMENT OF AN ACCURATE DESIGN CORRELATION FOR SUPERCRITICAL HEAT TRANSFER APPLICATIONS

PROJECT LEADERS

M Rohde

RESEARCH THEME

Complex dynamics of fluids

PARTICIPANTS

V Valori, M Rohde, G Elsinga,
N Warncke, J Westerweel,
T van der Hagen

COOPERATIONS

-

FUNDED

STW	
University	-
FOM	-
STW	100 %
NWO Other	-
Industry	-
TNO	-
GTI	-
EU	-
Scholarships	-

START OF THE PROJECT

2013

INFORMATION

V Valori
015 278 6821
v.valori@tudelft.nl

PROJECT AIM

This project aims to develop an accurate, physically sound design correlation for heat transfer in supercritical fluids. The correlation should prevent expensive oversizing of industrial equipment (required to avoid overheating) and stimulate the production of better products and more efficient processes.

PROGRESS

The building of the Rayleigh-Bénard cell to work at supercritical conditions was completed and the first commissioning tests were done. The high pressure facility was equipped with Particle Image Velocimetry (PIV) instrumentation. PIV measurements in a Rayleigh-Bénard cell to study non-Boussinesq (NB) effects at atmospheric pressure were finished and complementary Background Oriented Schlieren (BOS) were done. The study of NB effects in Rayleigh-Bénard at atmospheric pressure was completed with the interpretation of the experimental results and a conference paper was written on this topic. A journal paper on the same topic with further observations was in preparation.

DISSERTATIONS

-

SCIENTIFIC PUBLICATIONS

1. Valori V., Elsinga G.E., Rohde M., Tummers M.J., Westerweel J., van der Hagen T.H.J.J., "Natural convection driven heat transfer in fluids with strongly variable properties: a Particle Image Velocimetry study", NURETH 16 Conference, Chicago, August 30th – September 4th, 2015.



AERODYNAMICS



Prof.dr.ir. H Bijl



Prof.dr. F Scarano



Prof.dr. S Hickel

The research in the Aerodynamics Group involves fundamentals of Fluid Dynamics and its applications to aerodynamic problems of relevance in Aerospace Engineering systems.

The activities cover boundary layer research in low speed and high-speed flows, including re-entry aero-thermodynamics, complex unsteady flows, fluid-structure interaction problems and aeroacoustics.

The group works in close connection with the Wind Energy section for the investigation of rotor blade aerodynamics. Specific flow control strategies by passive (e.g. vortex generators) and active means (suction, plasma actuators) are explored for their application in flow transition and separation delay.

The experimental research is supported by the Aerodynamics Laboratories, which cover flow simulation range from incompressible to hypersonic regime. Emphasis is given to the development and application of image based advanced flow diagnostic techniques like Tomographic PIV, Background Oriented Schlieren, InfraRed Thermography.

The study of Fluid-Structure interactions and of unsteady flow simulation drive the development of efficient simulation tools for 3D-unsteady viscous flows (e.g. adaptive meshing, mimetic methods, multiscale computation of turbulence). Applications range from flapping wings and micro aerial vehicle aerodynamics to aircraft flutter and unsteady loads on wind turbines. The research on CFD also covers quantification of uncertainties in aerodynamics problems simulation.

DNS AND LES OF ROTATING TURBULENCE

PROJECT AIM

The plan for this thesis project is to perform Direct Numerical Simulations (DNS) of (1) high Reynolds number homogeneous rotating turbulence and (2) rotating turbulent wake flow at large Reynolds and small Rossby number to study the anisotropic effect of rotation on: coherent structures; spectra; budget of spectral turbulence energy; spectral eddy diffusivity and viscosity. At the end of the thesis we are going to better understand the fundamental flow physics of rotating turbulence and the implications on turbulence modeling. We will also attempt to develop LS models for the wake evolution far downstream of wind turbines.

PROGRESS

The project started August 1, 2015. So far, we have developed and validated a new pseudo spectral DNS solver from scratch.

DISSERTATIONS

-

SCIENTIFIC PUBLICATIONS

-

PROJECT LEADERS

S Hickel

RESEARCH THEME

Complex dynamics of fluids

PARTICIPANTS

T Pestana

COOPERATIONS

.....

FUNDED

University 100 %

FOM -

STW -

NWO Other -

Industry -

TNO -

GTI -

EU -

Scholarships -

START OF THE PROJECT

2015

INFORMATION

S Hickel

+31 152 789 570

S.Hickel@tudelft.nl

www.lr.tudelft.nl/aerodynamics

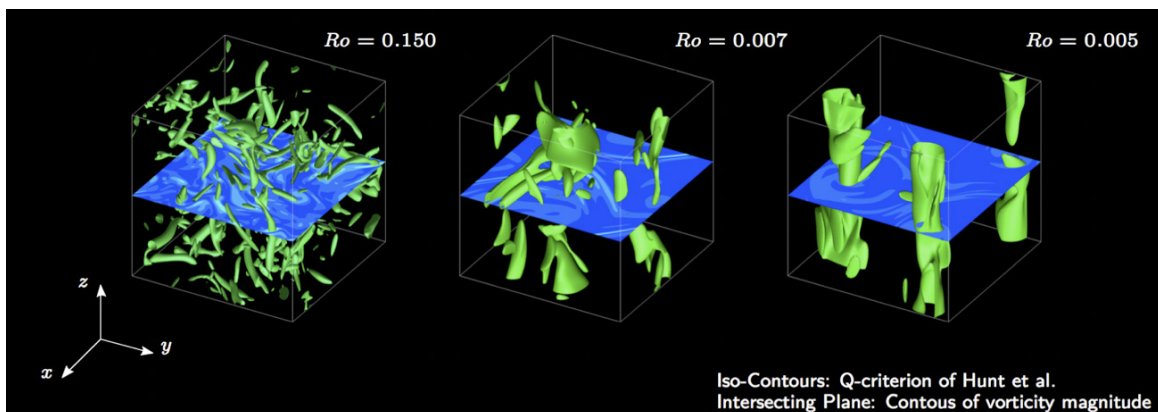

PIV-BASED NON-INTRUSIVE DETERMINATION OF UNSTEADY AERODYNAMIC LOADS

PROJECT LEADERS

BW van Oudheusden, F Scarano,
FFJ Schrijer

RESEARCH THEME

Complex dynamics of fluids

PARTICIPANTS

PL Blinde, K Lynch, JFG Schneiders

COOPERATIONS

DNW, CNRS, DLR, Uni BW Munich,
University of Southampton, ONERA,
TU Berlin, Istanbul TU, Univ Calgary,
LaVision GmbH

FUNDED

EU FP-7 (NIOPLEX)	
University	20 %
FOM	-
STW	-
NWO Other	-
Industry	-
TNO	-
GTI	-
EU	80 %
Scholarships	-

START OF THE PROJECT

2006

INFORMATION

BW van Oudheusden
015 278 5349
B.W.vanOudheusden@tudelft.nl
<http://www.tudelft.nl/>

PROJECT AIM

Novel non-intrusive experimental approaches are developed and applied to determine the flow-field pressure, as well as the integral aerodynamic loads on objects, from flow velocity data measured with particle image velocimetry (PIV). This is achieved by combining the flow field information with basic momentum principles. Apart from looking at the fundamental principles (notably 3D flow effects) the project also addresses the development of practical procedures.

PROGRESS

- 1) Extension of PIV-based determination of mean pressure in a transonic base flow investigation with relevance to launcher-afterbody buffeting.
- 2) Theoretical study of PIV-based determination of instantaneous pressure in a transonic base flow, based on a numerical data set.
- 3) Continuation of the FP-7 funded collaborative project (NIOPLEX: www.nioplex.eu) in this research area, which is coordinated by TU Delft and involves an international consortium of 9 partners

DISSERTATIONS

-

SCIENTIFIC PUBLICATIONS

1. P. Blinde, K. Lynch, F. Schrijer and B. van Oudheusden: Determination of instantaneous pressure in a transonic base flow using four-pulse tomographic PIV; PIV2015, Santa Barbara, CA, 14-16 Sept. 2015.
2. P.L. Blinde, V. Gentile, B.W. van Oudheusden, F.F.J. Schrijer: Determination of instantaneous pressure fields in a low-speed axisymmetric base flow based on time-resolved tomographic PIV, NIM2015 Workshop on Non-Intrusive Measurements for unsteady flows and aerodynamics, Poitiers, France, 27-29 Oct. 2015

SIMULATION OF TURBULENT CAVITATING FUEL FLOW IN A DIESEL INJECTOR DURING A FULL INJECTION CYCLE AND PRIMARY JET BREAKUP

PROJECT AIM

We perform large-eddy simulations (LES) of the turbulent multiphase flow inside Diesel injectors during one full injection cycle of Diesel fuel into air. We employ a barotropic two-phase two-fluid model, where all components (i.e. air, liquid Diesel, gaseous Diesel) are represented by a homogenous mixture approach. The cavitation model is based on a thermodynamic equilibrium assumption. Compressibility of all phases enables full resolution of collapse-induced pressure wave dynamics. The simulation includes a prescribed needle movement obtained from a multi domain simulation and the injector geometry is represented by an immersed boundary method.

PROGRESS

We have published a paper on our new conservative cut-element immersed boundary method, which was developed for cavitating liquid flows with moving geometries. Our barotropic two-phase two-fluid model for air, liquid Diesel and gaseous Diesel has been validated based on an experiment by Sou et al. (2006), which is a generic scaled-up fuel injector of an automotive engine. Finally, we performed well-resolved LES of the fuel flow through a 9-hole common rail Diesel injector during a full injection cycle. The analysis of the turbulent flow field reveals that the opening and closing phase are dominated by small-scale turbulence, while in the main injection phase large vortical structures are formed in the needle volume and reach into the nozzle holes. Violent collapse events of cavitation structures are detected during the closing phase in the nozzle holes, and after closing in the sac hole region. The needle movement has significant effects on flow features at low needle lifts.

DISSERTATIONS

-

SCIENTIFIC PUBLICATIONS

1. Örley, F., Hickel, S., Schmidt, S.J., Adams, N.A. (2015) LES of cavitating flow inside a Diesel injector including dynamic needle movement. *Journal of Physics Conference Series* 656: 012097.
2. Örley, F., Trummel, T., Hickel, S., Mihatsch, M.S., Schmidt, S.J., Adams, N.A. (2015) Large-eddy simulation of cavitating nozzle and jet flows. *Journal of Physics Conference Series* 656: 012096.
3. Örley, F., Trummel, T., Hickel, S., Mihatsch, M.S., Schmidt, S.J., Adams, N.A. (2015) Large-eddy simulation of cavitating nozzle flow and primary jet break-up. *Physics of Fluids* 27: 086101.
4. Örley, F., Pasquariello, V., Hickel, S., Adams, N.A. (2015) Cut-element based immersed boundary method for moving geometries in compressible liquid flows with cavitation. *Journal of Computational Physics* 283: 1-22.

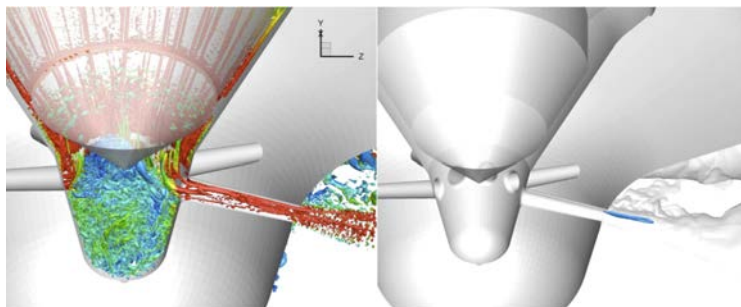

PROJECTLEADERS

S Hickel, S.J Schmidt, NA Adams

RESEARCHTHEME

Complex dynamics of fluids

PARTICIPANTS

F Oerley, M Mihatsch, T Trummel, CP Egerer

COOPERATIONS

Technische Universität München, Bosch

FUNDED

DFG, Bosch, LRZ, HLRS

FOM	-
STW	-
NWO Other	40 %
Industry	60 %
TNO	-
GTI	-
EU	-
Scholarships	-

START OF THE PROJECT

2010

INFORMATION

S Hickel
+31 152 789 570
S.Hickel@tudelft.nl
www.lr.tudelft.nl/aerodynamics

PROJECT LEADERS

SJ Hulshoff, H Bijl

RESEARCH THEME

Mathematical and computational methods for fluid flow analysis

PARTICIPANTS

Lei Cheng, Linfeng Chen, Ilya Popov

COOPERATIONS

Andrey Starikovskiy, Princeton.

FUNDED

Chinese Scholarships Council (CSC), TUDelft

University	10 %
FOM	-
STW	-
NWO Other	-
Industry	-
TNO	-
GTI	-
EU	-
Scholarships	90 %

START OF THE PROJECT

2008

INFORMATION

S Hulshoff
015 2781538
s.j.hulshoff@tudelft.nl

PROJECT AIM

To combine low-order physical and numerical modeling techniques to minimize the cost of simulating viscous flow control problems. This includes the goal-oriented optimization of basis functions, stabilization parameters, and adaptation. The problems considered include transition control via plasma actuators, near-wall turbulent flows and fluid-structure interactions.

PROGRESS

Reduced-order models of turbulent channel flow using multiscale unresolved-scale modelling were developed and validated. Efficient implementations of reduced-order models were achieved using both OpenMPI and CUDA. A semi-continuous formulation for identifying goal-oriented bases for reduced-order models was extended from the Burgers to the Stokes equations. Work concerning the development of model for NS-DBD actuators in flow computations was finalized.

DISSERTATIONS

1. L. Chen “Aspects of POD-based Wall-layer Modeling for the Variational Multiscale Method”, TU Delft, October 30 2015

SCIENTIFIC PUBLICATIONS

1. Cheng, Lei, Mattei, Stefano, Fick, Peter W. Hulshoff, Steven “A semi-continuous formulation for goal-oriented reduced-order models: 1D problems” International Journal for Numerical Methods in Engineering, 105, 6. pp 464—480.

COMPUTATIONAL SIMULATION OF NON-SYNCHRONOUS VIBRATIONS AND LOCK-IN PHENOMENON OF COMPRESSOR BLADES

PROJECT AIM

This project aims at the simulation and validation of non-synchronous vibrations and lock-in phenomenon of compressor blades. In general, non-synchronous vibrations occur due to the interaction of an aerodynamic instability with blade vibrations. These aerodynamic instabilities, typically encountered in turbo-machinery are dynamic separation, tip flow vortices and instabilities, and other secondary flows. Two modeling methods, the harmonic balance and the non-linear harmonics approach, will be investigated to describe the flow physics leading to non-synchronous vibration and lock-in.

PROGRESS

The harmonic balance and the non-linear harmonic approaches are applied to a two-dimensional, elastically mounted, cylinder test case, which experiences lock-in. The cylinder test case indicates whether both models are capable of sufficiently modeling the unsteady effects occurring during non-synchronous vibrations and model the lock-in effect. In a second phase a single row of a compressor is modeled, which, after validation, is extended with multiple rows.

DISSERTATIONS

-

SCIENTIFIC PUBLICATIONS

-

PROJECTLEADERS

A.H. van Zuijlen, H. Bijl

RESEARCHTHEME

Complex dynamics of fluids

PARTICIPANTS

Mirja de Vries

COOPERATIONS

DLR, MTU Aero Engines

FUNDED

Faculty of Aerospace Engineering

University 100 %

FOM -

STW -

NWO Other -

Industry -

TNO -

GTI -

EU -

Scholarships -

START OF THE PROJECT

2013

INFORMATION

AH van Zuijlen

015 278 2046

A.H.vanZuijlen@tudelft.nl

www.lr.tudelft.nl/aerodynamics

EFFICIENT NUMERICAL SIMULATION TECHNIQUES FOR AEROELASTIC, AEROACOUSTIC AND FLUID-STRUCTURE-CONTROLLER INTERACTION PROBLEMS

PROJECT LEADERS

A.H. van Zuijlen, H. Bijl

RESEARCH THEME

Mathematical and computational methods for fluid flow analysis

PARTICIPANTS

David Blom, Liesbeth Florentie, Thijs Gillebaart, Shaafi Kaja Kamaludeen, Dhruv Mehta, Wouter van der Velden, Ye Zhang

COOPERATIONS

ECN, Siemens Wind Power, University of Stuttgart, Technical University München, University of Siegen, Technical University Darmstadt

FUNDED

Siemens Wind Power, German Research Foundation (DFG), EU, Shell, FOM, STW, CSC University -
FOM 14%
STW 14%
NWO Other -
DFG 14%
Industry 14%
TNO -
GTI -
EU 28%
Scholarships 14%

START OF THE PROJECT

2012

INFORMATION

AH van Zuijlen
015 278 2046
A.H.vanZuijlen@tudelft.nl
www.lr.tudelft.nl/aerodynamics

PROJECT AIM

This project combines the efforts of seven separate PhD projects that involve numerical simulation of wind energy related problems: from large scale (wind farms) to mid scale (rotor/blade) to small scale (vortex generators, trailing edge serrations). The applications include aero-elasticity, aero-acoustics and fluid-structure-controller-interactions. The aim is to reduce computational time of high-fidelity modeling through energy conserving discretizations (wind farm wake modeling), acceleration by low-fidelity models using multi-fidelity optimization techniques, and parallel partitioned coupling techniques to enable massively parallel fluid-structure-acoustic interaction.

PROGRESS

On the wind farm scale, a review and implementation of several viscosity models for vortex particle methods (VPM) is done. The VPM is used as a low fidelity model in a simplified wind farm optimization. On the blade scale the Lattice Boltzmann method is used to analyze the effect of different transition devices and the self-noise generated by the tripping device. To model vortex generators, the BAY body force model is analyzed for the sensitivity of the resulting solution to both shape and magnitude of the body force. An adjoint based optimization is used to find the optimal source distribution to improve the BAY model. On the computational modeling side, Spectral Deferred Correction and Picard Integral Exponential Solver algorithms are used in OpenFOAM to obtain high order accuracy in time. These methods are suitable for parallel time integration and will next be applied to fluid-structure-interaction.

DISSERTATIONS

-

SCIENTIFIC PUBLICATIONS

1. Blom, D.S., van Zuijlen, A.H., Bijl, H. Multi-level acceleration with manifold mapping of strongly coupled partitioned fluid-structure interaction, *Computer Methods in Applied Mechanics and Engineering*, 296, pp. 211-231, 2015.
2. Van Der Velden, W.C.P., Van Zuijlen, A.H., De Jong, A.T., Bijl, H. Estimation of spanwise pressure coherence under a turbulent boundary layer, *AIAA Journal*, 53 (10), pp. 3134-3138, 2015.
3. Blom, D.S., Krupp, V., Van Zuijlen, A.H., Klimach, H., Roller, S., Bijl, H. On parallel scalability aspects of strongly coupled partitioned fluid-structure-acoustics interaction, *COUPLED PROBLEMS 2015 - Proceedings of the 6th International Conference on Coupled Problems in Science and Engineering*, pp. 556-565, 2015.

LOW-FREQUENCY UNSTEADINESS OF TURBULENT AXISYMMETRIC WAKE FLOWS

PROJECT AIM

Investigation of the low-frequency unsteadiness dominating the near-wake dynamics of turbulent wake flows past bluff bodies of revolution by means of high speed Particle Image Velocimetry.

PROGRESS

- Effect of diameter ratio on the wake topology and unsteadiness of an axisymmetric base flow (article accepted for publication in AIAA Journal, paper presented at Scitech 2015);
- Role of axial symmetric in the reattachment process (see above);
- Spatio-temporal characterization of the low-frequency unsteadiness of the axisymmetric turbulent wake (article submitted to Physics of Fluids, poster presented at TSFP9);
- Effect of diameter ratio on the azimuthal organization of the axisymmetric turbulent wake flow (paper presented at ICJWSF 2015);
- Effect of angular misalignments on the axisymmetric turbulent wake dynamics (article in preparation for submission to JFM rapids, abstract submitted to 18th Lisbon International Symposium);

DISSERTATIONS

-

SCIENTIFIC PUBLICATIONS

1. Gentile, V, Schrijer, FFJ, Oudheusden, BW van & Scarano, F (2015). Afterbody effects on axisymmetric base flows. In s.n. (Ed.), Proceedings of the 53rd AIAA aerospace sciences meeting (pp. 1-15). Reston: AIAA.
2. Gentile, V, Schrijer, FFJ, Oudheusden, BW van & Scarano, F (2015). Organization of an axisymmetric turbulent wake in presence of a central protrusion. In s.n. (Ed.), Proceedings of the international conference on jets, wakes and separated flows (pp. 1-6). Stockholm: KTH.
3. Gentile, V, Schrijer, FFJ, Oudheusden, BW van & Scarano, F (2015). Time-dependent behaviour of the recirculation region behind an axisymmetric bluff-body. In S Tavoularis & I Marusic (Eds.), Proceedings of the 9th symposium on turbulence and shear flow phenomena (pp. 1-6). Melbourne: University of Melbourne.
4. Blinde, PL, Gentile, V, Oudheusden, BW van & Schrijer, FFJ (2015). Determination of instantaneous pressure in an axisymmetric base flow using time-resolved tomographic PIV. In L David & A Beaudoin (Eds.), Proceedings of the workshop on non-intrusive measurements for unsteady flows and aerodynamics, NIM2015 (pp. 76-80). Poitiers: University of Poitiers.

PROJECTLEADERS

B van Oudheusden, FFJ Schrijer,
F Scarano

RESEARCHTHEME

Complex dynamics of fluids

PARTICIPANTS

Valeria Gentile

COOPERATIONS

Names of national and international cooperations (when relevant).

FUNDED

Beatrix de Rijk
University -
FOM -
STW -
NWO Other -
Industry -
TNO -
GTI -
EU -
Scholarships 100 %

START OF THE PROJECT

2012

INFORMATION

V Gentile
015 278 7095
V.Gentile@tudelft.nl

ANALYSIS OF FLAPPING-FLIGHT PROPULSION

PROJECT LEADERS

H Bijl, BW van Oudheusden

RESEARCH THEME

Complex dynamics of fluids

PARTICIPANTS

WB Tay, M Percin, S Deng

COOPERATIONS

Univ. Michigan, AFRL

FUNDED

STW

University -

FOM -

STW 75 %

NWO Other -

Industry -

TNO -

GTI -

EU -

Scholarships 25 %

START OF THE PROJECT

2010

INFORMATION

BW van Oudheusden

015 278 5349

B.W.vanOudheusden@tudelft.nl

www.tudelft.nl/

PROJECT AIM

The project considers fundamental and applied research on aerodynamic characterization for flapping-wing propulsion for the flight regime of small Micro Aerial Vehicles ($Re \sim 10,000$). Specific challenges are the occurrence of highly unsteady flow features resulting from massive separation, wing-wing interaction and the high amount of wing flexibility.

PROGRESS

The work has two major fields of attention: 1) the study of generic aeroelastic phenomena relevant to MAV propulsion and 2) a more detailed characterization of the aerodynamic behavior of the flapping-wing DeIFly MAV itself. A wind tunnel study was directed towards the characterization of the DeIFly in both hover and forward flight configurations, using multiple-plane stereo-PIV. Secondly, flow visualizations in a water tank were performed to investigate the effect of transient vortex formation of low-aspect ratio wings (connected to the RTO AVT-202 work group). Further activities were undertaken to the simulation of 3D clap-and-fling wing interactions, applying IBM and deforming-overset grid approaches.

DISSERTATIONS

1. M. Percin: Aerodynamic mechanisms of flapping flight, TU Delft, 23-09-2015, 239 pages

SCIENTIFIC PUBLICATIONS

1. W.B. Tay, B.W. van Oudheusden, H. Bijl: Numerical simulation of a flapping four-wing micro-aerial vehicle, *Journal of Fluids and Structures*, 55 (2015), pp. 237-261
2. W.B. Tay, S.H. Deng, B.W. van Oudheusden, H. Bijl: Validation of immersed boundary method for the numerical simulation of flapping wing flight, *Computers and Fluids*, 115, pp. 226-242 (2015).

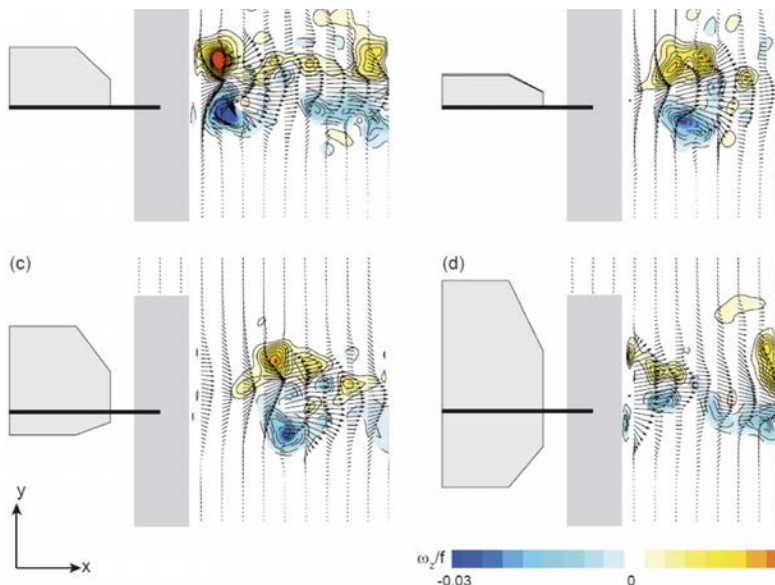

Experimental visualization of the wake behind the flapping wings of the DeIFly MAV in hovering flight configuration (M. Percin, Ph.D. thesis, 2015)

AC-DBD FORCED LAMINAR SEPARATION BUBBLES

PROJECT AIM

The main focus of the research is on dynamics of Laminar Separation Bubbles and their spatio-temporal response to external forcing. The latter is performed by means of Alternating Current Dielectric Barrier Discharge (AC-DBD) plasma actuators.

PROGRESS

Following the deliverables of the funding project in which cooperation with DAF took place (CONVENIENT FP7-TRANSPORT), five successful experimental campaigns have been carried out on forced Laminar Separation Bubbles. The first three involved Planar PIV on a flat plate with adverse pressure gradient. The fourth, involved planar PIV on a NACA 0018 airfoil, performed at the University of Waterloo in Canada. The fifth, was a time-resolved, tomographic-PIV experiment on a flat plate. Several conclusions have been drawn regarding the convectively unstable disturbance propagation, the rapid contraction of the bubble following the disturbance, the bursting dependence on magnitude and the stabilization of the forced LSB. These conclusions are currently summarized and compiled into journal publications.

DISSERTATIONS

-

SCIENTIFIC PUBLICATIONS

1. Michelis, T. & Kotsonis, M. 2015 Flow control on a transport truck side-mirror using plasma actuators. *Journal of Fluids Engineering, Transactions of the ASME* 137 (11)
2. Michelis, T. & Kotsonis, M. 2015 Interaction of an off-surface cylinder with separated flow from a bluff body leading edge. *Experimental Thermal and Fluid Science* 63

PROJECT LEADERS

M Kotsonis, F Scarano

RESEARCH THEME

Complex dynamics of fluids

PARTICIPANTS

Theodoros Michelis

COOPERATIONS

University of Waterloo

DAF Trucks B.V.

FUNDED

EU, TU Delft

University 25 %

FOM -

STW -

NWO Other -

Industry -

TNO -

GTI -

EU 75 %

Scholarships -

START OF THE PROJECT

2013

INFORMATION

T Michelis

06 81396042

t.michelis@tudelft.nl

HIGH SPEED FLOWS AND COMPRESSIBLE TURBULENCE

PROJECT LEADERS

FFJ Schrijer, BW van Oudheusden,
F Scarano

RESEARCH THEME

Complex dynamics of fluids

PARTICIPANTS

R. Giepmans, K. Lynch, Q. Ye, P
Blinde

COOPERATIONS

ESA, VKI, DLR, NLR, ASTRIUM,
TNO, ONERA, UNINA

FUNDED

EU (TFAST), ESA (TRAV2), CSC	
University	40 %
FOM	-
STW	-
NWO Other	-
Industry	-
TNO	-
GTI	-
EU	35 %
Scholarships	25 %

START OF THE PROJECT

2003

INFORMATION

F Schrijer
015 278 6386
f.f.j.schrijer@tudelft.nl

PROJECT AIM

Development and implementation of non-intrusive measurement techniques for high-speed compressible flows with special focus on particle image velocimetry. The measurement techniques are subsequently used to investigate flow phenomena that are pertinent to launchers, high-speed air transport systems and reentry vehicles. Specific topics that are studied are shockwave boundary layer interaction and control, compressible boundary layer transition and compressible baseflows.

PROGRESS

- 1) Investigation of flow control by means of micro-ramps of shock wave boundary layer interactions
- 2) Study and control of transitional shock-wave boundary layer interactions (EU FP7 project TFAST)
- 3) Investigation of compressible and incompressible launcher baseflows using (tomographic) PIV and PIV-based pressure integration.
- 4) Experimental investigation of (hypersonic) boundary layer transition using tomographic particle image velocimetry.

DISSERTATIONS

-

SCIENTIFIC PUBLICATIONS

1. R.H.M. Giepmans, F.F.J. Schrijer, B.W. van Oudheusden: Infrared Thermography Measurements on a Moving Boundary-Layer Transition Front in Supersonic Flow, *AIAA Journal*, 53 (2015), pp. 2056-2061
2. R.H.M. Giepmans, F.F.J. Schrijer, B.W. van Oudheusden: High-resolution PIV measurements of a transitional shock wave-boundary layer interaction, *Experiments in Fluids* (2015) 56:113
3. R. Giepmans, R. Louman, F. Schrijer, B. van Oudheusden: Experimental investigation of boundary layer tripping devices for shock wave-boundary layer control, *AIAA Aviation 2015*, 22-26 June 2015, Dallas, TX, AIAA-2015-2780.
4. R.H.M. Giepmans, A. Srivastava, F.F.J. Schrijer, B.W. van Oudheusden: The effects of Mach and Reynolds number on the flow mixing properties of micro-ramp vortex generators in a supersonic boundary layer, *AIAA Aviation 2015*, 22-26 June 2015, Dallas, TX, AIAA-2015-2779.
5. W.G. van Veen, R.H.M. Giepmans, F.F.J. Schrijer, B.W. van Oudheusden: RANS modeling of shock wave-boundary layer interactions, *YIC GACM 2015 (3rd ECCOMAS Young Investigators Conference, 6th GACM Colloquium)*, Aachen, Germany, 20-23 July 2015.
6. P. Blinde, S. Powell, F. Schrijer and B. van Oudheusden: Experiments on a hot plume base flow interaction at Mach 2. *8th European Symposium on Aerothermodynamics for Space Vehicles*, 2-6 March 2015, Lisbon, 7 pp.
7. Avallone, F, Greco, CS, Schrijer, FFJ & Cardone, G (2015). A low-computational-cost inverse heat transfer technique for convective heat transfer measurements in hypersonic flows. *Experiments in Fluids*, 56(86), 86-1-86-12.
8. Blinde, PL, Lynch, KP, Schrijer, FFJ & Oudheusden, BW van (2015). Determination of instantaneous pressure in a transonic base flow using four-pulse tomographic PIV. *PIV2015*, Santa Barbara, CA, 14-16 Sept. 2015.
9. Ye, Q, Schrijer, FFJ & Scarano, F (2015): Geometry effect of isolated roughness on boundary layer transition investigated by tomographic PIV. *TSFP 9*, July 2015, Melbourne.

LARGE-SCALE TOMOGRAPHIC PIV

PROJECT AIM

The project aims at developing tomographic PIV for three-dimensional measurements over large scales (thousands of cubic centimeters). Sub-millimeter helium-filled soap bubbles (HFSB) are used as flow tracers due to their high light scattering efficiency. The project will investigate the aerodynamic and light scattering characteristics of the HFSB. Applications of large-scale tomographic PIV for investigating the flow dynamics of high Reynolds number flows are planned both in academic and industrial facilities.

PROGRESS

The aerodynamic properties of the HFSB have been characterized by comparison with conventional flow tracers used in PIV. A novel seeding system has been introduced to achieve sufficient flow tracers concentration for large-scale PIV measurements. The seeding system relies upon the accumulation of the HFSB in a cylindrical reservoir over a time of about a minute and their injection into the flow in a short time interval (about a second). The fundamental relationships between nozzle's production rate, tracers concentration and measurement dynamic spatial range have been derived. Time-resolved measurements have been conducted to investigate the near wake of a surface mounted cylinder, where the three-dimensional pressure field has been retrieved from the velocity and acceleration data.

DISSERTATIONS

-

SCIENTIFIC PUBLICATIONS

1. Scarano F, Ghaemi S, Caridi GCA, Bosbach J, Dierksheide U and Sciacchitano A, On the use of helium-filled soap bubbles for large-scale tomographic PIV in wind tunnel experiments, *Exp Fluids* (2015) 56:42
2. Caridi GCA, Ragni D, Sciacchitano A and Scarano F, A seeding system for large-scale tomographic PIV in aerodynamics, 11th International Symposium on Particle Image Velocimetry – PIV15, Santa Barbara, California, September 14-16, 2015
3. Schneiders JFG, Caridi GCA, Sciacchitano A and Scarano F, Large-volume pressure from tomographic PTV in a surface mounted cylinder near-wake using HFSB tracers, *Proceedings of the Workshop on Non-Intrusive Measurements for Unsteady Flows and Aerodynamics, NIM2015, Poitiers (France), Oct. 27-29, 2015*
4. Sciacchitano A, Caridi GCA and Scarano F, A quantitative flow visualization technique for on-site sport aerodynamics optimization, 7th Asia-Pacific Congress on Sports Technology, APCST 2015, *Procedia Engineering* 112 (2015) 412-417

PROJECTLEADERS

F Scarano, A Sciacchitano

RESEARCHTHEME

Complex dynamics of fluids

PARTICIPANTS

G. Caridi

J. Schneiders

W. Terra

A. Popinhak

COOPERATIONS

LaVision GmbH

FUNDED

Partly by LaVision GmbH and by
ERC Proof of Concept

University 50 %

FOM -

STW -

NWO Other -

Industry 25 %

TNO -

GTI -

EU 25 %

Scholarships -

START OF THE PROJECT

2013

INFORMATION

A Sciacchitano

015 278 8692

a.sciacchitano@tudelft.nl

CFD2PIV – ON THE USE OF GOVERNING EQUATIONS VIA CFD FOR PIV DATA POST-PROCESSING

PROJECT LEADERS

F Scarano, RP Dwight

RESEARCH THEME

Mathematical and computational methods for fluid flow analysis

PARTICIPANTS

J.F.G. Schneiders, I. Azijli

COOPERATIONS

-

FUNDED

STW – MuST, TNO, LaVision

University 25 %

FOM -

STW 20 %

NWO Other -

Industry 25 %

TNO 30 %

GTI -

EU -

Scholarships -

START OF THE PROJECT

INFORMATION

F Scarano

015 278 5902

f.scarano@tudelft.nl

www.lr.tudelft.nl/aerodynamics/

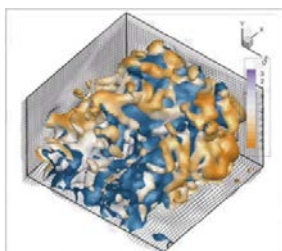
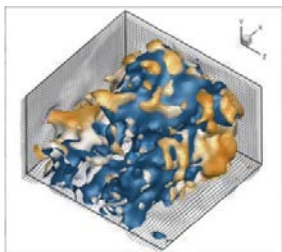
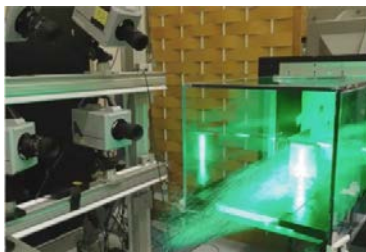

PROJECT AIM

The research explores the blending of CFD and 3D or 4D PIV (space and time resolved) data resulting from tomographic PIV measurements. Three main objectives are pursued:

- 1) Increasing temporal resolution (time supersampling), spatial resolution (pouring time into space, data assimilation) and velocity dynamic range (Lagrangian data filtering);
- 2) Expanding the dimension of the measured domain, filling internal gaps and increasing the number of observed variables (e.g. pressure from PIV);
- 3) Quantifying error and uncertainty in the numerical post-processing (e.g. influence of measurement error, and uncertain BCs on predicted pressure).

PROGRESS

The research has focused on the application of the Vortex-in-Cell (VIC) scheme for a generalized time-supersampling technique in incompressible flows. The VIC method was then applied to obtain pressure estimates from tomographic PIV without the need for time resolved measurements. The reduction of measurement errors was studied by imposing mass conservation (solenoidal filter). Finally, pouring time into space is being explored using an advanced VIC scheme that combines static (velocity) and dynamical (acceleration) information to produce a dense estimation of the velocity field from sparse tracers trajectories. A large-volume tomographic PIV measurements of the flow past a truncated cylinder has been performed to validate the methods. The figure below shows the experiment setup (left) and the reconstructed velocity using VIC (middle) and VIC+ (right).

DISSERTATIONS

-

SCIENTIFIC PUBLICATIONS

1. JFG Schneiders, I Azijli, F Scarano, RP Dwight: Pouring time into space, 11th International Symposium on Particle Image Velocimetry, PIV15, Santa Barbara (US), 2015
2. JFG Schneiders, RP Dwight, F Scarano: Tomographic PIV noise reduction by simulating repeated measurements, 11th International Symposium on Particle Image Velocimetry, PIV15, Santa Barbara (US), 2015
3. I Azijli, RP Dwight: Solenoidal filtering of volumetric velocity measurements using Gaussian process regression, *Experiments in Fluids* 56, 1-18, 2015
4. JFG Schneiders, G Caridi, A Sciacchitano, F Scarano: Large-volume pressure from tomographic PIV in a surface mounted cylinder near-wake using HFSB tracers, Workshop on Non-Intrusive Measurements for Unsteady Flows and Aerodynamics, NIM2015, Poitiers (France), 2015
5. I. Azijli, A. Sciacchitano, D. Ragni, A. Palha, R.P. Dwight: A posteriori uncertainty quantification of PIV-based pressure data, 11th International Symposium on Particle Image Velocimetry, PIV15, Santa Barbara (US), 2015 (to appear: *Experiments in Fluids*).

REAL-GAS EFFECTS IN TRANSCRITICAL MULTI-PHASE INJECTION AND MIXING AT HIGH PRESSURE

PROJECT AIM

Many of today's energy conversion devices are operated at high pressures, at which the fluid properties significantly deviate from those of an ideal gas. Typical examples for such high-pressure applications are, for instance, liquid rocket engines, stationary gas turbines that are operated as an organic Rankine cycle, and high-pressure Diesel engines. We develop high-fidelity multi-physics simulation methods for such devices. Particular challenges are modeling accuracy and computational efficiency due to the strongly non-linear changes of fluid properties close to the pseudoboiling line.

PROGRESS

We have developed a multi-species real gas thermodynamics framework within our LES solver INCA and validated the thermodynamic models and turbulence models (Matheis et al. (2016), Müller et al. (2015, 2016) and Matheis et al. (2015)). Additionally to the fully conservative formulation (FC) of the governing equations, we have recently developed a numerical approach where the total energy conservation equation is replaced by a pressure evolution equation, which leads to a quasi conservative (QC) formulation of the finite volume method. The figure shows snapshots of the temperature obtained with a QC pressure evolution equation and with the FC method for case E4 of Oswald's (1999) experiment, where QC seems to under-predict the cooling effect during real-gas mixing. Currently we are analyzing the differences between the FC and QC methods, with particular emphasis on energy conservation and thermodynamic consequences of numerical errors.

DISSERTATIONS

-

SCIENTIFIC PUBLICATIONS

1. Müller, H., Pfitzner, M., Matheis, J., Hickel, S. (2015) Large-eddy simulation of coaxial LN₂/GH₂ injection at trans- and supercritical conditions. Journal of Propulsion and Power.
2. Matheis, J., Müller, H., Pfitzner, M., Hickel, S. (2015) Large-eddy simulation of coaxial LN₂/GH₂ injection at supercritical pressures. In proceedings of 9th International Symposium on Turbulence and Shear Flow Phenomena (TSFP9); Melbourne, Australia.

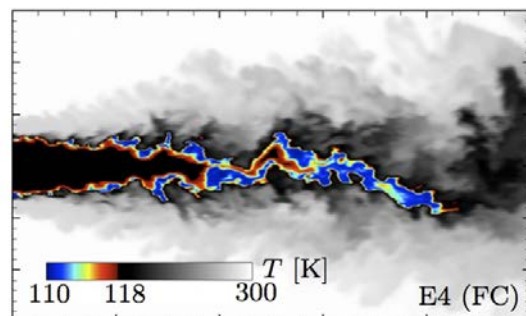
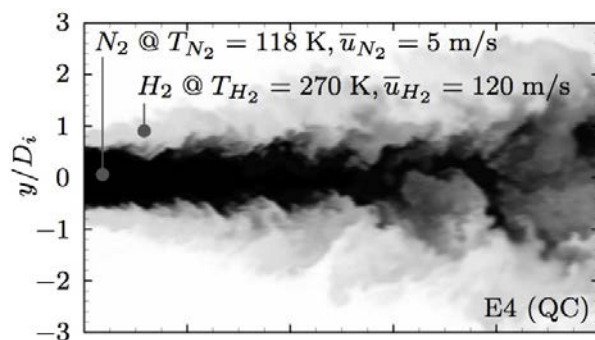

PROJECT LEADERS

S Hickel

RESEARCH THEME

Mathematical and computational methods for fluid flow analysis

PARTICIPANTS

J Matheis, H Müller, M Pfitzner

COOPERATIONS

Technische Universität München,
Universität der Bundeswehr
München

FUNDED

DFG	
FOM	-
STW	-
NWO Other	100 %
Industry	-
TNO	-
GTI	-
EU	-
Scholarships	-

START OF THE PROJECT

2012

INFORMATION

S Hickel
015 278 9570
S.Hickel@tudelft.nl
www.lr.tudelft.nl/aerodynamics

CROSS-FLOW INSTABILITY OF SWEEPED WINGS BOUNDARY LAYERS

PROJECT LEADERS

M Kotsonis

RESEARCH THEME

Complex dynamics of fluids

PARTICIPANTS

Jacopo Serpieri, MSc

COOPERATIONS

-

FUNDED

University	-
FOM	-
STW	-
NWO Other	100 %
Industry	-
TNO	-
GTI	-
EU	-
Scholarships	-

START OF THE PROJECT

2013

INFORMATION

M Kotsonis
M.Kotsonis@tudelft.nl

PROJECT AIM

Aim of the project is the investigation of the cross-flow instability acting in three-dimensional boundary layers. This characterizes the transition mechanism on swept wings therefore its evident relevance. This research exploits state of the art flow diagnostic experimental to investigate the flow evolution in the latest staged of transition. Furthermore, towards the goal of delaying transition, the most advanced flow control strategies are deployed. The research aims hence in being a high-impact experimental investigation of this flow instability mechanism.

PROGRESS

In about 27 months from its start, the project saw the design and realization of the wind-tunnel model. The flow stability and the transition pattern have been inspected by means of flow visualization experiments as well as theoretical stability models. Thereafter quantitative measurements have been performed making use of hot-wire anemometry in perfect agreement with the literature studies and game-changing tomographic PIV. The latter yielding to volumetric simultaneous measurements, allows the investigation of the complex flow structures in a detail reached so far only in numerical-theoretical frameworks. The main outcomes of the performed research are the object of a journal article recently submitted to the Journal of Fluid Mechanics.

DISSERTATIONS

-

SCIENTIFIC PUBLICATIONS

1. Authors: Jacopo Serpieri and Marios Kotsonis Title: Flow visualization of swept wing wind boundary layer transition. Conference: 10th Pacific Symposium on Flow Visualization and Image Processing, 15-18 June 2015, Naples, Italy.
2. Authors: Jacopo Serpieri and Marios Kotsonis Title: Design of a swept wing wind tunnel model for study of cross-flow instability. Conference: 33rd AIAA Applied Aerodynamics Conference, AIAA Aviation, 22-26 June 2015, Dallas USA. Paper: AIAA 2015-2576



ENVIRONMENTAL FLUID MECHANICS



Prof.dr.ir. AJHM Reniers



Prof.dr. JD Pietrzak



Prof.dr.ir. WSJ Uijttewaal



Prof.dr. G Stelling



Prof.dr.ir. JC Winterwerp

The Environmental Fluid Mechanics Group performs fundamental, process-oriented research on fluid flow problems of practical relevance in water management, environmental engineering, hydraulic engineering and coastal engineering. To enhance the potential of practical applications, the section not only aims at writing publications, as far as scientific output is concerned, but also at the production of software that is available via internet. Examples of software packages are SWAN (Simulating Waves Nearshore) and SWASH (Simulating Waves till Shore). Free surface flow models based upon unstructured grids are in preparation and will be released in coming years. Within this philosophy the research program encompasses the following main items:

- Free surface waves in coastal zones with topics such as: Generation and prediction of (hurricane) storm impacts, harbour seiches, dynamics of surf beat and the wave models SWAN and SWASH.
- Elementary Fluid Mechanics and Turbulence in the context of rivers, coastal areas and open ocean with the following topics: turbulence and flow structures in rivers and its flood planes, stability and transport under waves and currents of rock elements in cover layers consisting of loose, granular material, transport and dispersion of the freshwater and SPM, the response of high-latitude climate change to mesoscale ocean eddies.
- Transport of suspended particulate matter with topics such as: advanced, experimental and numerical work concerning particle-turbulence interaction as well as flocculation and sedimentation processes
- Numerical model development with topics such as: development of the non-hydrostatic models for the investigation of dam breaks including inundations, short wave problems, near field plume discharges, stratified flows, and local scour near dams, unstructured grids via finite volume methods and finite element methods and development of large scale integrated 1d/2d rainstorm drainage/flooding model applicable to rural and urban areas.

SEDIMENT FOR SALTMARSHES: PHYSICAL AND ECOLOGICAL ASPECTS OF A MUD MOTOR

PROJECT AIM

The Mud Motor is a Building With Nature initiative with the aim to re-use dredged material for ecological purposes. The pilot project envisages the disposal of sediments, dredged in the Port of Harlingen, at strategic locations along the Kimstergat Channel. This extra supply of sediment is expected to promote the growth and stability of salt marshes, improving the efficiency of the Wadden Sea ecosystem services and the coastal protection from flooding. The likely reduction of sediment recirculation into the harbour area will be an additional benefit, leading to a reduction in dredging costs.

PROGRESS

Preliminary analyses of bathymetric data, indicated net accretion in the area over the 20th century. The Kimstergat Channel during the same period has migrated towards the coast and has extended in the northeast direction. The transect at the envisioned location Koehool shows a significant accretion in the last century (see Figure). However, the deposition rates decreased in the last decades. Furthermore, in proximity of the coastline, the bed levels are not growing above the 0m NAP, but there is a seaward progradation of the tidal flat. Identification and quantification of the processes responsible for these morphological changes are currently the focus of this research. This implies the unravelling of the interaction between wind-waves and tidal-currents. Based on this knowledge, the transport mechanisms that bring sediments from the disposal site to the salt-marshes will be determined.

DISSERTATIONS

-

SCIENTIFIC PUBLICATIONS

-

PROJECT LEADERS

JC Winterwerp, AJHM Reniers,
BC van Prooijen, DS van Maren

RESEARCH THEME

Complex dynamics of fluids

PARTICIPANTS

I Colosimo

COOPERATIONS

Deltares, NIOZ, IMARES

FUNDED

STW	
University	-
FOM	-
STW	100 %
NWO Other	-
Industry	-
TNO	-
GTI	-
EU	-
Scholarships	-

START OF THE PROJECT

2015

INFORMATION

I Colosimo
015 278 9631
I.Colosimo@tudelft.nl

Bed level changes from 1926 to 2010 (left); Transect at Koehool. Accreting bed-levels from 1926 to 2010 (right)

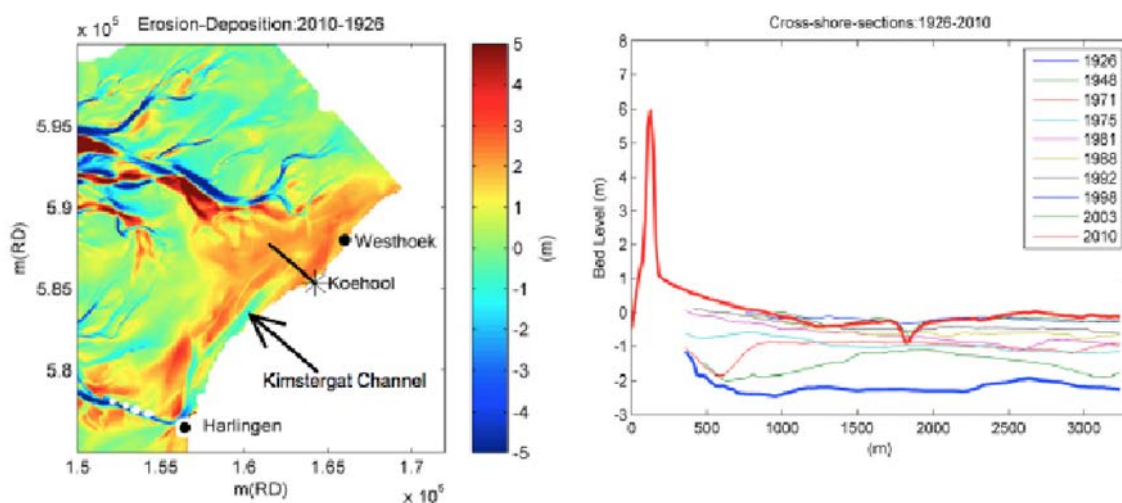

MORPHOLOGICAL RESPONSE OF TIDAL FLATS - FROM UNDERSTANDING TOWARDS MANAGEMENT GUIDELINES (EMERGO)

PROJECT LEADERS

BC van Prooijen, ZB Wang

RESEARCH THEME

Complex dynamics of fluids

PARTICIPANTS

PLM de Vet

COOPERATIONS

NIOZ, Deltares, Svasek,
Rijkswaterstaat, WWF,
Natuurmonumenten

FUNDED

NWO (no. 850.13.021), Deltares,
Svasek, NIOZ and Rijkswaterstaat
University -
FOM -
STW -
NWO Other 70 %
Industry 30 %
TNO -
GTI -
EU -
Scholarships -

START OF THE PROJECT

2014

INFORMATION

PLM de Vet
P.L.M.deVet@tudelft.nl

BC van Prooijen
B.C.vanProoijen@TUDelft.nl
emergoproject.wordpress.com

PROJECT AIM

The main objective of this research is to develop morphological knowledge resulting in design rules for mitigation measures to counteract the reduction of intertidal areas.

PROGRESS

In the first year of the project, we performed extensive data analyses on the morphology of the intertidal flats in the Eastern and Western Scheldt. We compared the morphological state and analyzed the evolution of individual flats. Changes in hydrodynamics have been related to changes in morphological trends, by which we indicated the impact of human interventions on the intertidal areas in these estuaries. The findings of this study will be submitted to a journal soon. Insights from this study contributed directly to ongoing nourishment projects in the Scheldt estuaries.

DISSERTATIONS

-

SCIENTIFIC PUBLICATIONS

1. Wang, Z. B., Van Maren, D. S., Ding, P. X., Yang, S. L., Van Prooijen, B. C., De Vet, P. L. M., J.C. Winterwerp, H.J. De Vriend, M.J.F. Stive, & He, Q. (2015). Human impacts on morphodynamic thresholds in estuarine systems. *Continental Shelf Research*, 111, 174-183.

STABILITY OF CARIBBEAN COASTAL ECOSYSTEMS UNDER FUTURE EXTREME SEA LEVEL CHANGES (SCENES), SUB-PROJECT B: BIOGEOMORPHIC MODELLING OF COMPLEX CARIBBEAN BAYS AND INLETS

PROJECT AIM

The research in this project focuses on modelling of the regional circulation in the geometrically complex Caribbean bays and lagoons, which are dominated by multi-scale flows. It explicitly aims to link our interdisciplinary research; from large scale climate change to the small scale biogeomorphology of the coastal bays and lagoons under study. To achieve this we use proven technology but uniquely couple the effect of long term climate change trends including short term extreme events on calcifying macro algae. The modelling systems applied in this project simulate tidal, wind and wave driven flows, wind waves from ocean basin to inlets scales using one integrated model domain and mesh, and a local biogeomorphology model. In particular, hydrodynamic features such as eddies, high flow gradients and wave transformation zones that form within and outside the bay and lagoon systems will be dynamically resolved at very high levels of localized mesh resolution. Parallel scalable model design will ensure that very high resolution grids can be efficiently simulated on high performance computers. Among the models and approaches being applied are the tightly coupled, unstructured mesh, parallel, SWAN+ADCIRC wave-current model developed by the University of Notre Dame, Delft University of Technology, the University of Texas at Austin, and the University of North Carolina at Chapel Hill together with Delft3D for biogeomorphology and POP for large-scale global dynamics of future climate scenarios.

PROGRESS

The challenge of generation and initialization of the integrated domains required to model the large range of scales demanded by the project is being tackled first. New methods and approaches are under development to produce unstructured mesh domains of the Caribbean region spanning the thousand kilometre basin scales of the Atlantic down to the small metre-scales of the geometrically-complex bays and lagoons. Initial models of the whole region in the integrated domains have been setup and run in massively-parallel simulations on the Dutch supercomputing resource Cartesius. Furthermore, new approaches to efficiently analyse and interpret model output are under development which are key when data spans such large spatial scales in this new integrated model.

DISSERTATIONS

-

SCIENTIFIC PUBLICATIONS

1. A.S. Candy, J.D. Pietrzak and M. Zijlema (2015) A multiscale analysis of the stability of Caribbean coastal ecosystems through the biogeomorphic modelling of its complex bays and inlets, Fourteenth International Workshop on Multiscale Unstructured Mesh Numerical Modelling for coastal, shelf and global ocean dynamics, Portland, Oregon.

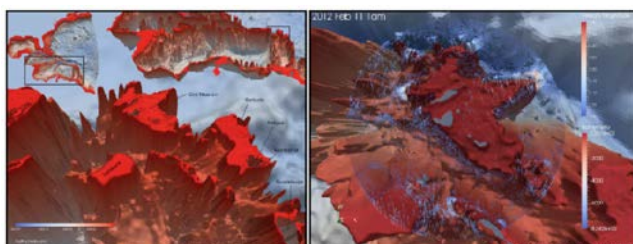

PROJECT LEADERS

JD Pietrzak, M Zijlema

RESEARCH THEME

Mathematical and computational methods for fluid flow analysis

PARTICIPANTS

AS Candy, JD Pietrzak, M Zijlema

COOPERATIONS

University of Notre Dame, IMAU (UU), NIOZ (Yerseke), University of Texas, University of North Carolina, North Carolina State University, Ohio State University

FUNDED

NWO (Caribbean Research Programme)	
University	-
FOM	-
STW	-
NWO Other	100 %
Industry	-
TNO	-
GTI	-
EU	-
Scholarships	-

START OF THE PROJECT

2015

INFORMATION

AS Candy
015 278 99 74
A.S.Candy@tudelft.nl

ADCIRC Finite element Caribbean ocean circulation model, showing (left) sea bed bathymetry surface of the unstructured meshed domain and (right) instantaneous flow vectors around Sint Maarten and Sababank of the Dutch Antillies.

RHEOLOGICAL CHARACTERISTICS OF FLUID MUD IN PORTS AND WATERWAYS

PROJECT LEADERS

C Chassagne, T Vellinga

RESEARCH THEME

Complex dynamics of fluids

PARTICIPANTS

A Kirichek (TU Delft), JC Winterwerp (TU Delft), C van Rhee (TU Delft), A Noordijk (Port of Rotterdam)

COOPERATIONS

Port of Rotterdam, Rijkswaterstaat

FUNDED

Port of Rotterdam	
University	-
FOM	-
STW	-
NWO Other	-
Industry	100 %
TNO	-
GTI	-
EU	-
Scholarships	-

START OF THE PROJECT

2015

INFORMATION

C Chassagne
015 278 5970
c.chassagne@tudelft.nl
<http://www.citg.tudelft.nl/over-faculteit/afdelingen/hydraulic-engineering/sections/environmental-fluidmechanics/staff/chassagne-c/>

PROJECT AIM

The goal of the project is to obtain a new, practical and reliable definition of a nautical bottom taking into account all the parameters that might influence the rheological properties of the fluid mud layer. These parameters will be linked to the properties of fluid mud and water. Dependence on the maritime activities (such as navigation or dredging) have also been shown to influence the mud characteristics. Rheological properties of the fluid mud should be investigated using rheological models and validated through field and laboratory experiments. An important aspect is the upscaling of the results of small-scale laboratory observations to the size of the ship.

PROGRESS

The state of the art has been developed. It covers the properties of the fluid mud and their link to rheological characteristics and ship maneuverability. One of the primary interests of the project is to find a suitable monitoring technique which allows to measure rheological properties in-situ. A series of field experiments has been conducted and high potential monitoring tools have been identified.

DISSERTATIONS

-

SCIENTIFIC PUBLICATIONS

-

SEDIMENT NOURISHMENT AS A SOLUTION TO AUTONOMOUS BED DEGRADATION OF THE RHINE RIVER: RESPONSE TO SEDIMENT OVERLOADING

PROJECT AIM

The main goal is to provide insights on the development of the morphodynamic pattern of rivers with sand-gravel mixtures during unsteady conditions. More specifically we study the influence of a lack of sediment supply on the evolution of a sand-gravel reach. To this end we created a new experimental data set for validation of numerical models for sand-gravel morphodynamics. We focus on the processes involved in the bed degradation of mixed sediment. Previous development by the participant of an image analysis tool has enabled detailed data regarding the evolution of the grain size distribution of the bed surface with time.

PROGRESS

The research focused on the analysis of the results of two laboratory experiments. A first laboratory experiment studied the effects of a limited sediment supply on grain size selective processes under degradational conditions. The experiment analyzed the formation of a static armor under conditions of partial transport of a bed composed of a bimodal sediment mixture. The laboratory experiment was reproduced applying a numerical morphodynamic model. A second laboratory experiment was conducted under fully mobile transport conditions using a trimodal sediment mixture. The experiment showed how an armor created under low flow conditions became unstable and reformed under higher flow rates. Detailed measurements of the spatial and temporal changes of the bed surface texture were provided for both experiments. A novel technique that allow to measure the bed surface texture during flow was used.

DISSERTATIONS

-

SCIENTIFIC PUBLICATIONS

1. Orrú C., Chavarrías V., Ferrara V., Stecca G., and Blom A., A laboratory experiment on the evolution of a sand gravel reach under a lack of sediment supply, E-proceedings of the 36th IAHRWorld Congress 28 June–3 July, 2015, The Hague, The Netherlands.

PROJECTLEADERS

WSJ Uijtewaal, A Blom

RESEARCHTHEME

Complex dynamics of fluids

PARTICIPANTS

C Orrú

COOPERATIONS

-

FUNDED

Cornelis Lely Sticing
Regional Government of Sardinia
(Italy) (Regione Autonoma della
Sardegna-Programma Master&Back)
Delft University of Technology
University -
FOM -
STW -
NWO Other -
Industry 25 %
TNO -
GTI -
EU -
Scholarships 75 %

START OF THE PROJECT

2011

INFORMATION

C Orrú
015 278 9624
C.Orru@tudelft.nl

EFFECTS OF LONGITUDINAL TRAINING WALL ON RIVER MORPHODYNAMIC

PROJECT LEADERS

WSJ Uijtewaal

RESEARCH THEME

Complex dynamics of fluids

PARTICIPANTS

L Thai Binh, A Crosato

COOPERATIONS

-

FUNDED

Vietnam International Education Development (VIED)

University -

FOM -

STW -

NWO Other -

Industry -

TNO -

GTI -

EU -

Scholarships 100 %

START OF THE PROJECT

2014

INFORMATION

L Thai Binh

06 47 252 698

T.B.Le@tudelft.nl.

PROJECT AIM

Recently, Engineers propose to substitute the classical transverse groynes with longitudinal training walls. The goal is to obtain an improved navigation channel, while preserving the river conveyance capacity during floods, and improve the river bank natural value. This study aims to define guidelines to optimize the geometry of a river channel with longitudinal walls to [1] maintain a stable system [2] improve navigation, [3] maintain the flood conveyance of the river, and [4] reduce maintenance costs.

PROGRESS

In the year of 2005, the authors carried out a series of experimental test in the Fluid Mechanics Laboratory of Delft University of Technology. These tests aim to verify the results of numerical simulations report by Le et al (2014). The preliminary results of the experimental tests tend to confirm what numerical simulation found. This study is under progress and more experimental tests will be carried out with different configurations, characterized by discharge, sediment, width of the side channel, length of the training wall and presence of opening points on the training wall, with and without sediment feeding.

DISSERTATIONS

-

SCIENTIFIC PUBLICATIONS

1. Le, T.B., Crosato, A., Uijtewaal, W.S.J. (2015). Long term effects of longitudinal training wall: a numerical study. IAHR world congress 07/2015. The Hague, The Netherlands.
2. Le, T.B., Crosato, A., Uijtewaal, W.S.J. (2015). Longitudinal training walls: morphodynamic effects of the starting point. Book of Abstracts NCR-Days 2015, Nijmegen, October 1-2, NCR-PUBLICATION 39-2015 (HJR Lenders, FPL Collas, GW Geerling and RSEW Leuven Eds.), pp. 69-72. Publisher: Netherlands Centre for River Studies (NCR), ISSN 1568-234X.
3. Mosselman, E., Le, T.B. (2015). Five common mistakes in fluvial morphodynamic modeling, *Advances in Water Resources*. <http://dx.doi.org/10.1016/j.advwatres.2015.07.025>.
4. Roelvink, F.E., Lako, A., Le, T.B., Crosato, A. (2015). Challenges in morphodynamic laboratory experiments. Book of Abstracts NCR-Days 2015, Nijmegen, October 1-2, NCR-PUBLICATION 39-2015 (HJR Lenders, FPL Collas, GW Geerling and RSEW Leuven Eds.), pp. 38-41. Publisher: Netherlands Centre for River Studies (NCR), ISSN 1568-234X.



THE MORPHODYNAMIC MODELING OF INTERTIDAL AREAS

PROJECT AIM

The objective of the project is to improve the morphodynamic modelling of intertidal areas, focusing on model improvement and better model usage. Morphodynamic and hydrodynamic processes are strongly coupled and cover a wide range of time and length scales. Therefore, a multiple-scale approach is required. Typical challenges in model improvement are dealing with the wetting and drying of shallow areas, the coupling between hydrodynamics and morphodynamics on the different length and time scales and the lack of accuracy of coarse and efficient models.

PROGRESS

The subgrid method of Casulli, 2009 uses small scale bathymetry information for simulations on a coarser grid. Based on a similar approach, a depth-averaged shallow water model is derived, that accounts for small scale bathymetry and roughness variations. The hydrodynamic results show a significant increase in accuracy, with only a slight increase in computation cost. We introduced a multiple grid approach to compute morphodynamics. The subgrid-based hydrodynamic model is coupled to a high resolution morphodynamic model. The morphodynamic model consists of a sediment transport equation and a mass balance. This gives a strong increase in accuracy of the results for the bed evolution and the concentration.

DISSERTATIONS

-

SCIENTIFIC PUBLICATIONS

1. Volp, N. D., B. C. van Prooijen, and G. S. Stelling (2013), A finite volume approach for shallow water flow accounting for high-resolution bathymetry and roughness data, *Water Resour. Res.*, 49, 4126–4135, doi:10.1002/wrcr.20324.
2. Volp, N. D., van Prooijen, B. C., Pietrzak, J. D., and Stelling, G. S. (2015). A subgrid based approach for morphodynamic modelling. *Advances in Water Resources*.

PROJECT LEADERS

GS Stelling, JD Pietrzak, BC van Prooijen

RESEARCH THEME

Mathematical and computational methods for fluid flow analysis

PARTICIPANTS

ND Volp

COOPERATIONS

Deltares, Rijkswaterstaat, BAW, Bundeswehr Universität München

FUNDED

Building with Nature, Ecoshape
University -
FOM -
STW -
NWO Other -
Industry 100 %
TNO -
GTI -
EU -
Scholarships -

START OF THE PROJECT

2009

INFORMATION

ND Volp
n.d.volp@tudelft.nl
015 278 4069

THREE-DIMENSIONAL FLOW AND TURBULENCE STRUCTURES AROUND THE EASTERN SCHELDT STORM SURGE BARRIER

PROJECT LEADERS

WSJ Uijtewaal, RJ Labeur

RESEARCH THEME

Complex dynamics of fluids

PARTICIPANTS

YB Broekema

COOPERATIONS

Department of Geo-Engineering
at the faculty of CEG, TUD.

Rijkswaterstaat.

FUNDED

Rijkswaterstaat

University -

FOM -

STW -

NWO Other -

Industry -

TNO -

GTI -

EU 100 %

Scholarships -

START OF THE PROJECT

2015

INFORMATION

Y Broekema

015 278 8129

Y.B.Broekema@tudelft.nl

<http://fluidmechanics.tudelft.nl>

PROJECT AIM

To obtain a detailed understanding of three-dimensional flow patterns and turbulence structures around the Eastern Scheldt storm surge barrier with special attention to near-bed processes. Through a combination of field data analysis, laboratory experiments and numerical modelling the flow phenomena will be related to the persistent scour at the edge of the bed protection. The obtained knowledge will be operationalized in a numerical flow model, to help Rijkswaterstaat come to a cost-effective and sustainable solution for the scour problems.

PROGRESS

During the first year of my PhD I started with an exploratory literature study on scouring mechanisms and flow phenomena around scour holes. Besides, I made an analysis on the flow data collected by Rijkswaterstaat near the scour holes. Building on those results, I am reworking the literature study, finding articles with a much clearer idea of the local phenomenology. Moreover, I am currently working on the planning of the full research trajectory, setting up an experimental program for the laboratory tests. Besides this, I am also looking into ways of collecting additional field data near the barrier itself that in a later stage can be used for validation of the numerical model.

DISSERTATIONS

-

SCIENTIFIC PUBLICATIONS

-

FLOCS AND FLUFF IN THE DELTA: TOWARDS DYNAMIC PARTICLE PROPERTIES IN A SPM MODEL FOR THE RHINE- SCHELDT ROFI

PROJECT AIM

Developing a full analytical model Particle Size Distribution (PSD) mode, for the water column and incorporating exchanges with the bed. Dependence of the model's relevant coefficients on external parameters, like shear, temperature, salinity, organic matter content, type of cohesive sediment will be analyzed. The analytical model, completely tested to be equivalent to the numerical (PSD) model, will be used to evaluate the dynamic settling velocity distribution (SVD) that is needed for large- scale models. The new SVD model will be implemented in Delft 3D and tested against the results of the large – scale survey performed in Sep- Oct 2014.

PROGRESS

Literature survey is ongoing. The samples collected during the survey have been analyzed. First important parameters have been identified.

DISSERTATIONS

-

SCIENTIFIC PUBLICATIONS

-

PROJECTLEADERS

C Chassagne, JP Pietrzak

RESEARCHTHEME

Complex dynamics of fluids

PARTICIPANTS

Z Safar, Dr. T van Kessel (senior researcher at Deltares), Prof.

A. Manning (senior scientist at HR Wallingford in the Coast and Estuaries Group), Prof. A. Souza (senior scientist at the National Oceanography Center (NOC) at Liverpool)

COOPERATIONS

Deltares, HR Wallingford, National Oceanography Center (NOC) at Liverpool

FUNDED

Netherlands Organization for Scientific Research, Earth and life Sciences

University -

FOM -

STW 100 %

NWO Other -

Industry -

TNO -

GTI -

EU -

Scholarships -

START OF THE PROJECT

2015

INFORMATION

C Chassagne

015 278 5970

c.chassagne@tudelft.nl

<http://www.citg.tudelft.nl/over-faculteit/afdelingen/hydraulic-engineering/sections/environmental-fluidmechanics/staff/chassagne-c/>

TRACING THE SINKING OF DENSE OCEAN WATERS IN THE NORTH ATLANTIC OCEAN

PROJECT LEADERS

CA Katsman

RESEARCH THEME

Complex dynamics of fluids

PARTICIPANTS

N Brüggemann (post-doc)

COOPERATIONS

Institute of Marine and Atmospheric
Research Utrecht, Utrecht University

FUNDED

NWO

University -

FOM -

STW -

NWO Other 100 %

Industry -

TNO -

GTI -

EU -

Scholarships -

START OF THE PROJECT

2015

INFORMATION

N Brüggemann

015 278 9974

n.bruggemann@tudelft.nl

PROJECT AIM

In this project, we investigate the sinking of dense water masses in the North Atlantic from an eddy permitting (0.1 degree) and non-eddy resolving (1 degree) global ocean model. Velocity fields of the model are used to advect Lagrangian floats. Model and float data are used to identify regions where water masses sink into the deep ocean, and to study the mechanisms governing the (ageostrophic) sinking of these dense water masses. This project is part of the NWO-ALW VIDI project "From small whirls to the global ocean: how ocean eddies govern the response of the Atlantic Meridional Overturning Circulation to high-latitude climate change", granted to C. A. Katsman.

PROGRESS

First simulations with the high-resolution ocean model code were performed. Progress was made regarding the identification of the ageostrophic dynamics by diagnosing the vorticity budget for the North Atlantic. Results indicate that sinking is related to eddy advection of relative vorticity and friction. By calculating Lagrangian quantities, like isopycnal depth/thickness and isopycnal transports, we also made first steps in diagnosing the pathways of dense water masses and their exit route out of the North Atlantic. This will be further investigated by diagnosing pathways of Lagrangian floats that are calculated based on the velocity fields of the global ocean model. Test simulations were already performed.

DISSERTATIONS

-

SCIENTIFIC PUBLICATIONS

1. Brüggemann, N., C. Katsman, S. Georgiou, S. Ypma, H. Dijkstra, 2015: Tracing the sinking of dense ocean waters in the North Atlantic Ocean. BBOS Autumn Symposium 2015, Renesse.

THE IMPACT OF THE LOCAL EDDY ACTIVITY ON DEEP CONVECTION AND SINKING OF DENSE WATERS IN THE LABRADOR AND IRMINGER SEAS

PROJECT AIM

The aim of this PhD is to investigate the impact of the local eddy activity on deep convection and sinking of dense waters in the Labrador and Irminger Seas. Using a highly idealized regional model fundamental research will be conducted in order to study the impacts of the local eddy activity on deep convection and sinking of dense waters in the Labrador and Irminger Seas.

This project is part of the NWO-ALW VIDI project "From small whirls to the global ocean: how ocean eddies govern the response of the Atlantic Meridional Overturning Circulation to high-latitude climate change], granted to C. A. Katsman.

PROGRESS

Over the last 10 months multi-year simulations of the convective cycle were performed for the Labrador Sea. The mixed layer depth and the eddy kinetic energy were diagnosed from the output data of the model, and are in good agreement with the observations, and the model displays a realistic seasonal cycle despite its simplicity. The primary aim of this study is to understand what determines the location of the convection region. Therefore, we will perform a series of sensitivity tests and analyze among others the heat budget in the central Labrador Sea.

DISSERTATIONS

-

SCIENTIFIC PUBLICATIONS

-

PROJECTLEADERS

CA Katsman

RESEARCHTHEME

Complex dynamics of fluids

PARTICIPANTS

S Georgiou, JD Pietrzak

COOPERATIONS

Woods Hole Oceanographic Institution, Woods Hole (USA)

FUNDED

NWO	
University	-
FOM	-
STW	-
NWO Other	100 %
Industry	-
TNO	-
GTI	-
EU	-
Scholarships	-

START OF THE PROJECT

2015

INFORMATION

S Georgiou
015 278 9340
S.Georgiou@tudelft.nl

SIDE CHANNELS AND EROSION OF NATURAL BANKS

PROJECT LEADERS

WSJ Uijttewaal

RESEARCH THEME

Complex dynamics of fluids

PARTICIPANTS

G Duró; P van Denderen.

COOPERATIONS

University of Twente and Utrecht
University

FUNDED

NWO-STW, University of Twente,
Rijkswaterstaat, LievenseCSO,
Royal HaskoningDHV and HKV
Consultants

University	-
FOM	-
STW	100 %
NWO Other	-
Industry	-
TNO	-
GTI	-
EU	-
Scholarships	-

START OF THE PROJECT

2015

INFORMATION

G Duró
015 278 8129
g.duro@tudelft.nl
[http://www.ncr-web.org/rivercare/
about](http://www.ncr-web.org/rivercare/about)

PROJECT AIM

The biogeomorphodynamics of trained rivers can be enhanced by leaving the banks unprotected and by creating side channels. Proper understanding and predictability of the morphodynamics are of key importance in the design of river restoration projects. The stability of the side channels, which should neither fill in rapidly nor erode and attract discharge, and the local processes governing the rate of bank erosion require attention as they determine the planform changes in the main and side channels with freely erodible vegetated banks.

PROGRESS

A literature review on bank erosion processes, field campaigns and data gathering are some of the activities performed to date.

DISSERTATIONS

-

SCIENTIFIC PUBLICATIONS

1. Duró, G., Crosato, A., Uijttewaal, W.S.J. Research on Natural Bank Erosion Processes, Book of Abstracts: Bridging gaps between river science, governance and management, NCR-days 2015, Radboud University, Nijmegen, October 1-2, 2015.

A HYBRID PARTICLE-MESH METHOD FOR SIMULATING FREE SURFACE FLOWS

PROJECT AIM

The project aims at constructing a numerical wave flume for the analysis of coastal structure. In order to achieve this a combined particle-mesh method is used which attempt to combine the advantages of Eulerian and Lagrangian methods.

PROGRESS

In the past year a simple implementation of a numerical wave flume was made using a hybrid particle-mesh approach. Advantages and disadvantages of the hybrid method were identified. In short, the advantages of the hybrid-particle mesh method are the straightforward implementation of kinematic boundaries, the representation and tracking of interfaces of complex topology and the relatively low computational costs. However, the particle distribution and the complex interaction between particles and grid can be mentioned to be disadvantages of the method. Future research aims at mitigating the problems observed in the first year.

DISSERTATIONS

-

SCIENTIFIC PUBLICATIONS

-

PROJECTLEADERS

WSJ Uijtewaal

RESEARCHTHEME

Mathematical and computational methods for fluid flow analysis

PARTICIPANTS

RJ Labeur

COOPERATIONS

-

FUNDED

NWO	
University	-
FOM	-
STW	-
NWO Other	100 %
Industry	-
TNO	-
GTI	-
EU	-
Scholarships	-

START OF THE PROJECT

2015

INFORMATION

J Maljaars

06 43720509

j.m.maljaars@tudelft.nl

SURF WAVE DYNAMICS IN THE COASTAL ENVIRONMENT

PROJECT LEADERS

G van Vledder, J Hanson,
LH Holthuijsen, K Ewans

RESEARCH THEME

Mathematical and computational
methods for fluid flow analysis

PARTICIPANTS

G van Vledder, J Hanson,
LH Holthuijsen, K Ewans

COOPERATIONS

Arcadis NL/Alkyon Hydraulic
Consultancy & Research, US
Army Corps of Engineers, Shell
International Exploration and
Production

FUNDED

Office of Naval Research, USA
Delft University of Technology, NL
University 100 %
FOM -
STW -
NWO Other -
Industry -
TNO -
GTI -
EU -
Scholarships -

START OF THE PROJECT

2010

INFORMATION

GPh van Vledder
015 278 3255
g.p.vanvledder@tudelft.nl

PROJECT AIM

Present state of the art wave models are still insufficiently accurate regarding shallow water dissipation and non-linear interactions in the coastal zone. This project will focus on three main areas; improvement of modelling capabilities of physical processes in the coastal zone, procurement, utilisation and dissemination of high quality datasets and the development, testing and dissemination of new source terms for third generation wave models.

PROGRESS

A new source term formulation for depth-induced wave breaking has been developed, calibrated and verified over an extensive selection of laboratory and field cases. A study investigating the implications and dependencies of this new source term was also carried out with particular emphasis on extreme wave conditions (a 1:4000 year storm). An inconsistency in the implementation of the LTA source term for triads has also been addressed and alternative triad models considered. Qualitatively, these alternatives provide superior results at the high frequency end of the spectrum. Research is now focused on the implications of the inconsistency for 2D field cases. Preliminary investigations on the effect of both the new depth-induced breaking and triad source terms have also been carried out. Analysis of spectral evolution is being carried out by USACE and Shell IEP.

DISSERTATIONS

-

SCIENTIFIC PUBLICATIONS

1. Salmon, J.E. & Holthuijsen, LH (2015). Modeling depth-induced wave breaking over complex coastal bathymetries. Coastal Engineering, 105, 21-35.

SUSTAINABLE ENGINEERING OF COASTAL SYSTEMS IN REGIONS OF FRESHWATER INFLUENCE

PROJECT AIM

The overall project consists of two subprojects. This subproject will focus on the interaction of stratification, turbulence and SPM within the Rhine Region of Freshwater Influence. The aim is to gain more insight into the complex phenomena in front of the Dutch coastal zone, such as the transport and dispersion of the freshwater and SPM, the hindered mixing by stratification, effect of tidal straining on the evolution of fronts. The role of turbulence in stratified flows plays a key role. In addition, high quality turbulence data will be used to improve turbulence models.

PROGRESS

In 2014 a large dataset with e.g. salinity, temperature, velocities, turbidity and buoyancy fluxes is obtained. The dataset obtains 4-6 weeks of data. The measurement site is off the Dutch coast near the Sand Engine. In 2015 the data is checked, processed and we started to analyze the data. The focus has been on the velocity, temperature and salinity data. We observe different behavior of the water column structure during different periods. Our knowledge of the hydrodynamics is improving. In addition, a start is made with setting up numerical modelling and calculating turbulence statistics from the velocity data.

DISSERTATIONS

-

SCIENTIFIC PUBLICATIONS

-

PROJECTLEADERS

JD Pietrzak, HJH Clercx

RESEARCHTHEME

Complex dynamics of fluids

PARTICIPANTS

S Rijnsburger

COOPERATIONS

Eindhoven University of Technology

National Oceanography Centre

University of Washington, Deltares

FUNDED

STW	
University	-
FOM	-
STW	100 %
NWO Other	-
Industry	-
TNO	-
GTI	-
EU	-
Scholarships	-

START OF THE PROJECT

2014

INFORMATION

S Rijnsburger

06 16385733

s.rijnsburger@tudelft.nl

HYDRAULIC IMPACT OF OVERTOPPING WAVES ON A MULTIFUNCTIONAL DIKE

PROJECT LEADERS

WSJ Uijttewaal

RESEARCH THEME

Complex dynamics of fluids

PARTICIPANTS

X Chen, Prof. Bas Jonkman
(Co-supervisor)

COOPERATIONS

Deltares, Flanders Hydraulic Res.
RWS, Waterdienst

FUNDED

STW	
University	-
FOM	-
STW	100 %
NWO Other	-
Industry	-
TNO	-
GTI	-
EU	-
Scholarships	-

START OF THE PROJECT

2011

INFORMATION

X Chen
06 86449343
X.Chen-2@tudelft.nl

PROJECT AIM

Multifunctional dikes can be designed in an infinite number of ways. The most relevant hydraulic issues are related to the impact of waves on various parts of the structure. So the aim of this project is to quantify the hydraulic impact of overtopping wave on residential buildings that are part of a multifunctional flood defense.

PROGRESS

After a literature study, experiments were performed in a wave flume at Flandres Hydraulics. The data analysis has resulted in a better description and understanding of the phenomena. These new insights makes it possible to predict extreme impacts in a more reliable way. Also the consequences of the wave impact on structures can now be assessed in a realistic way accounting for material strength and geometrical aspects of the structure. This study has reached its final year in which the thesis will become available.

DISSERTATIONS

-

SCIENTIFIC PUBLICATIONS

1. Xuexue Chen, Bas Hofland, Corrado Altomare, Tomohiro Suzuki, Wim Uijttewaal, Forces on a vertical wall on a dike crest due to overtopping flow, Coastal Engineering, Volume 95, January 2015, Pages 94-104, ISSN 0378-3839, <http://dx.doi.org/10.1016/j.coastaleng.2014.10.002>.

ASSESSING THE ROLE OF EDDIES ON DEEP CONVECTION AND THE SINKING OF DENSE WATERS IN THE NORDIC SEAS

PROJECT AIM

The research aim is to understand the connection between ocean eddies, deep ocean convection, the properties of the boundary currents and the sinking of dense waters in the Nordic Seas (between Greenland, Iceland and Norway), and to study the sensitivity of the deep convection and sinking to changing environmental conditions. For this, a high resolution, idealized, regional ocean model will be developed. This project is part of the NWO-ALW VIDI project "From small whirls to the global ocean: how ocean eddies govern the response of the Atlantic Meridional Overturning Circulation to high-latitude climate change", granted to C. A. Katsman.

PROGRESS

Currently, the development of the ocean model for the Nordic Seas is in its first stages.

DISSERTATIONS

-

SCIENTIFIC PUBLICATIONS

-

PROJECT LEADERS

CA Katsman, JD Pietrzak

RESEARCH THEME

Complex dynamics of fluids

PARTICIPANTS

SL Ypma

COOPERATIONS

University of Bergen (Norway) - planned

FUNDED

NWO	
University	-
FOM	-
STW	-
NWO Other	100 %
Industry	-
TNO	-
GTI	-
EU	-
Scholarships	-

START OF THE PROJECT

2015

INFORMATION

S Ypma
015 278 1953
s.l.ypma@tudelft.nl

LONG-TERM NUMERICAL MODELLING OF SEDIMENT MANAGEMENT MEASURES

PROJECT LEADERS

A Blom, WSJ Uijttewaal

RESEARCH THEME

Mathematical and computational methods for fluid flow analysis

PARTICIPANTS

ECMM Arkesteijn

COOPERATIONS

RWS, Twente University

FUNDED

STW

University -

FOM -

STW 70 %

NWO Other -

Industry 30 %

TNO -

GTI -

EU -

Scholarships -

START OF THE PROJECT

2014

INFORMATION

L Arkesteijn

e.c.m.m.arkesteijn@tudelft.nl

PROJECT AIM

The main objective of this project is to assess and improve numerical techniques to predict the large scale channel response to sediment augmentation measures. Large scale morphodynamic changes take place on the long-term (i.e. 100-1000 years). Performing numerical simulations on these scales requires rather large computation times. Techniques such as the application of reduced flow models (e.g. assumption of steady or normal flow), or a morphodynamic factor are frequently applied to overcome this. In this project we will assess the existing techniques, focus on improving them, and study the effects of nourishment projects in the Rhine by application of a new or improved tool.

PROGRESS

The project has been ongoing for one year, in which mainly literature was studied and a project work plan was written. The literature review was focused on 1) the application of sediment management measures in the Rhine and other large rivers worldwide, 2) studies addressing the effects of sediment management measures, and 3) the pros and cons of existing mathematical and numerical models for describing/predicting flow and morphodynamics.

DISSERTATIONS

-

SCIENTIFIC PUBLICATIONS

-

HYDRODYNAMIC MODELING OF BAFFIN BAY

PROJECT AIM

The project aim is to gain a deeper insight in the flow dynamics of Baffin Bay. To achieve this goal a high-resolution flow model which includes such phenomena as stratification, topographic steering, wind forcing, tides, waves, currents and ice is to be developed. The model is to be validated against available data.

PROGRESS

The tidal model of the Canadian Arctic Archipelago set up previously was extended to include time varying wind forcing and ice concentration fields. The model results are compared with the available tide gauge data. Influence of wind and ice cover on the tidal dynamics was examined. The computed velocity fields were used to evaluate tidal energy flux and the positions of tidal mixing fronts.

DISSERTATIONS

-

SCIENTIFIC PUBLICATIONS

-

PROJECT LEADERS

J Pietrzak

RESEARCH THEME

Mathematical and computational methods for fluid flow analysis

PARTICIPANTS

O Kleptsova, J Pietrzak

COOPERATIONS

-

FUNDED

University -
FOM -
STW -
NWO Other -
Industry -
TNO -
GTI -
EU -
Scholarships -

START OF THE PROJECT

2014

INFORMATION

O Kleptsova
015 278 4784
O.S.Kleptsova@TUDelft.nl

Computed vs observed M2 amplitude (left) and phase (right)

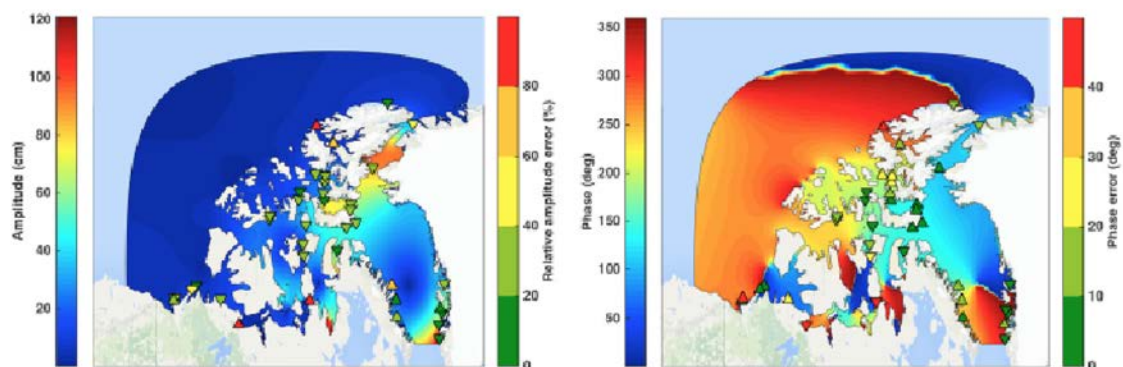

EVOLUTION OF CLAY FLOC SIZES AS FUNCTION OF POLYMER TYPE, DOSAGE AND SHEAR STRESSES /

PROJECT LEADERS

C Chassagne

RESEARCH THEME

Complex structures of fluids

PARTICIPANTS

M Ibanez, C Chassagne,

H Winterwerp

COOPERATIONS

PECSA, Université Paris-Sorbonne,

Cordouan Tech., Deltares

FUNDED

Netherlands Organization for
Scientific Research, Earth and life
Sciences

University 50 %

FOM -

STW -

NWO Other -

Industry 50 %

TNO -

GTI -

EU -

Scholarships -

START OF THE PROJECT

2011

INFORMATION

C Chassagne

015 278 5970

c.chassagne@tudelft.nl

<http://www.citg.tudelft.nl/over-faculteit/afdelingen/hydraulic-engineering/sections/environmental-fluidmechanics/staff/chassagne-c/>

PROJECT AIM

The aim is to link the physical properties of cohesive sediment to its chemical characteristics. In order to assess these properties the following measurements are performed: electrokinetic characterization of the surface charge, consolidation measurements, particle size distribution in time. Models are subsequently developed to link all these properties.

PROGRESS

The experiments regarding the floc size distribution as function of time, shear, polymer dose, etc... and the settling velocity of suspensions in settling columns, varying polymer dose, clay concentration and mixing methods are done. Methods are currently applied on the consolidation results. A PhD thesis is written. Two publications are in preparation.

DISSERTATIONS

-

SCIENTIFIC PUBLICATIONS

-

A STUDY ON WAVE-INDUCED RESPONSES OF MOORED FLOATING BODIES EMBEDDED IN A LARGE SCALE WAVE MODEL

PROJECT AIM

An accurate prediction of the response of a ship, moored in a harbor or coastal region, to the local wave climate (a composite of short and infragravity waves) is of great importance for safe operations of the ship (e.g. loading and offloading activities). This project aims to develop a numerical model system that can resolve the evolution of waves, and their impact on a restrained (i.e., non-moving) ship that is moored in a realistic harbor or coastal region. This work is based on the recently developed non-hydrostatic wave-flow model SWASH, which has shown to be a powerful tool to simulate the nearshore short-wave dynamics.

PROGRESS

As infragravity waves play a key role in the wave-induced response of moored ships, we studied the capabilities of SWASH in resolving the nearshore transformation of infragravity waves in a realistic coastal region. Furthermore, a non-moving body has been schematized in SWASH to account for the interactions of waves with a restrained ship. The model has been validated using both an analytical solution, laboratory experiments, and field measurements. The findings of this project demonstrate the model's potential in simulating the evolution of the waves and their impact on a moored ship at the scale of a realistic harbor or coastal region.

DISSERTATIONS

-

SCIENTIFIC PUBLICATIONS

1. Rijnsdorp, D. P., Ruessink, G., & Zijlema, M. (2015). Infragravity-wave dynamics in a barred coastal region, a numerical study. *Journal of Geophysical Research: Oceans*, 120(6), 4068–4089. doi:10.1002/2014JC010450.

PROJECTLEADERS

JD Pietrzak, M Zijlema

RESEARCHTHEME

Mathematical and computational methods for fluid flow analysis

PARTICIPANTS

DP Rijnsdorp

COOPERATIONS

Sichuan University, Chengdu, China

FUNDED

NWO	
University	-
FOM	-
STW	-
NWO Other	100 %
Industry	-
TNO	-
GTI	-
EU	-
Scholarships	-

START OF THE PROJECT

2011

INFORMATION

DP Rijnsdorp

d.p.rijnsdorp@tudelft.nl

ACCOUNTING FOR SEDIMENT SORTING IN MODELLING SEDIMENT MANAGEMENT MEASURES

PROJECT LEADERS

A Blom, WSJ Uijttewaal

RESEARCH THEME

Complex dynamics of fluids

PARTICIPANTS

V Chavarrias

COOPERATIONS

RWS, Utrecht U., Twente U

FUNDED

STW

University -

FOM -

STW 70 %

NWO Other -

Industry 30 %

TNO -

GTI -

EU -

Scholarships -

START OF THE PROJECT

2014

INFORMATION

V Chavarrias

v.chavarriasborras@tudelft.nl

PROJECT AIM

In order to predict the morphodynamic effects of sediment management measures (e.g. Figure 1), models are used to characterize the physical processes occurring in a river. The aim of this project is to improve modelling of sediment management measures. We will focus on (1) restoration of hyperbolicity (well-posedness) of the set of conservation equations in mixed sediment modelling, (2) accounting for dune sorting (i.e., lee face sorting and the dune-covered mobile armour) and dune geometry in mixed sediment modelling, and (3) modelling the effects of dredging and sediment augmentation measures.

PROGRESS

We have analytically evaluated the loss of hyperbolicity of the different state-of-the-art models for mixed-sediment morphodynamics. A tool has been developed to numerically check whether the present approach is well or ill-posed. We have found that the domain of ill-posedness is larger than previously thought. In order to gain insight into the physical processes that occur when the model is ill-posed we have run a first laboratory experiment. We aim at conducting a set of experiment that will provide a data set to develop a new model.

DISSERTATIONS

-

SCIENTIFIC PUBLICATIONS

1. V. Chavarrias, G. Stecca, A. Siviglia, and A. Blom (2015), Ellipticity of the Saint-Venant-Hirano model for mixed-sediment river morphodynamics. Proceedings of the 9th symposium of River, Coastal, and Estuarine Morphodynamics, Iquitos, Peru.

Sediment nourishment in the Rhine





GEOSCIENCE & REMOTE SENSING



Prof.dr.ir. HJJ Jonker



Prof.dr.ir. AP Siebesma

This group studies an entirely new research field using existing expertise in fluid mechanics and turbulence at TU Delft to address important questions in the field of weather and climate. Special attention is paid to the role of clouds, of which relatively little is known. It is believed that clouds could have a considerable impact on the size of the estimated enhanced greenhouse effect.

HIGH RESOLUTION MODELING OF DEEP CUMULUS CONVECTION

PROJECT AIM

A realistic representation of deep cumulus clouds remains one of the most challenging problems in atmospheric modeling. Numerical Weather Prediction and climate models, in which deep convection is parametrized, tend to predict the onset of deep convection too early during the day. We will investigate the transition from shallow clouds to deep convection using the Dutch Atmospheric Large Eddy Simulation (DALES) model. The simulation results of DALES will be used to determine the relative roles of gradual moistening of the cloud layer and the organization of the boundary layer below cloud base.

PROGRESS

Project has been finished. The thesis, entitled "The interaction between deep convective clouds and their environment" has been defended successfully on January 2014.

DISSERTATIONS

1. The interaction between deep convective clouds and their environment. January 14, S Böing.

SCIENTIFIC PUBLICATIONS

-

PROJECTLEADERS

HJJ Jonker, AP Siebesma

RESEARCHTHEME

Complex dynamics of fluids

PARTICIPANTS

SJ Böing, HJJ Jonker, AP Siebesma,
SR de Roode

COOPERATIONS

KNMI, Dr. W.Grabowski (NCAR,
Boulder,Colorado,U.S.A)

FUNDED

TU Delft	
University	100 %
FOM	-
STW	-
NWO Other	-
Industry	-
TNO	-
GTI	-
EU	-
Scholarships	-

START OF THE PROJECT

2009

INFORMATION

S Böing
015 278 3478
s.j.boing@tudelft.nl
www.grs.citg.tudelft.nl

CLOUD-CLIMATE FEEDBACK: THE ROLE OF BOUNDARY LAYER CLOUDS

PROJECT LEADERS

SR de Roode, AP Siebesma

RESEARCH THEME

Complex dynamics of fluids

PARTICIPANTS

J van der Dussen, SR de Roode, AP Siebesma

COOPERATIONS

KNMI, + 12 other EU partners involved in EUCLIPSE

FUNDED

EU	
University	-
FOM	-
STW	-
NWO Other	-
Industry	-
TNO	-
GTI	-
EU	100 %
Scholarships	-

START OF THE PROJECT

2010

INFORMATION

J van der Dussen
015 278 4720
J.J.vanderDussen@tudelft.nl
www.grs.citg.tudelft.nl

PROJECT AIM

The cloud response due to the enhanced greenhouse effect remains the largest source of uncertainty in climate model projections of a future climate. The EU-funded Cloud Intercomparison, Process Study & Evaluation Project (EUCLIPSE) aims to reduce the uncertainty in the representation of cloud processes and feedbacks in the new generation of Earth System Models (ESMs). This sub-project will use the Dutch Atmospheric Large-Eddy Simulation model to study in detail turbulent flows in cloudy atmospheres. Central question is how the vertical atmospheric stability controls the spatial coverage and depth of low clouds like stratocumulus and shallow cumulus.

PROGRESS

Project has been finished. The thesis will be defended on June 22, 2015.

DISSERTATIONS

-

SCIENTIFIC PUBLICATIONS

-

DROPLET-TURBULENCE DYNAMICS UNDER HETEROGENEOUS CONDITIONS

PROJECT AIM

The focus will be on the evolution of droplet size distributions under a sharp gradient in the mean gas velocity, the droplet concentration and the background humidity. The goal of this project is to understand the interplay between the turbulence dynamics, and the droplet distribution. The two key questions to be addressed are: What is the influence of shear in the mixing layer on the droplet distribution and dispersion, droplet collisions and coalescence efficiency. How are the dispersion, collision frequency and coalescence efficiency influenced by the orientation of the mixing layer with respect to gravity?

PROGRESS

Three manuscripts have been written and have been submitted for review. The project has been finished. The thesis will be defended on June 19, 2015.

DISSERTATIONS

-

SCIENTIFIC PUBLICATIONS

-

PROJECTLEADERS

HJJ Jonker

RESEARCHTHEME

Complex dynamics of fluids

PARTICIPANTS

V Perrin, HJJ Jonker

COOPERATIONS

Prof W. vd Water (TUE)

Humberto Bocanegra Evans (TUE)

FUNDED

FOM

University -

FOM 100 %

STW -

NWO Other -

Industry -

TNO -

GTI -

EU -

Scholarships -

START OF THE PROJECT

2010

INFORMATION

V Perrin

015 278 9174

v.e.perrin@tudelft.nl

www.grs.citg.tudelft.nl

PREDICTIVE LARGE-EDDY-SIMULATIONS: IMPROVING CLOUD AND PRECIPITATION FORECASTING

PROJECT LEADERS

HJJ Jonker, AP Siebesma

RESEARCH THEME

Complex dynamics of fluids

PARTICIPANTS

J Schalkwijk, HJJ Jonker,
AP Siebesma, RAJ Neggers

COOPERATIONS

KNMI

FUNDED

TUD, KNMI

University 50 %

FOM -

STW -

NWO Other -

Industry 50 %

TNO -

GTI -

EU -

Scholarships -

START OF THE PROJECT

2010

INFORMATION

J Schalkwijk

015 278 9174

J.Schalkwijk@tudelft.nl

www.grs.citg.tudelft.nl

PROJECT AIM

Current weather and climate models do not have sufficient resolution to explicitly resolve low cloud evolution, and therefore use statistical models for this purpose. This program aims to improve prediction accuracy by using Large Eddy Simulations (LES) to perform the needed high-resolution calculations and integrate this in large-scale prediction models. Excessive computational requirements always forced reasonable domain LES to run on supercomputing facilities, whose batch queuing protocols inhibit interaction. This program aims to solve this using Graphical Processing Units (GPUs) to provide the necessary computational power.

PROGRESS

Two papers have been written, which are currently in press: J. Schalkwijk, H.J.J. Jonker, A.P. Siebesma, F. Bosveld. A Year-Long Large-Eddy Simulation of the Weather over Cabauw: an Overview. 2015. Monthly Weather Review. J. Schalkwijk, H.J.J. Jonker, A.P. Siebesma, E. van Meijgaard. Weather Forecasting using GPU-based Large-Eddy Simulations. 2015. Bulletin of the American Meteorological Society. The thesis will be defended on April 21, 2015.

DISSERTATIONS

-

SCIENTIFIC PUBLICATIONS

-

URBAN CLIMATE AT STREET SCALE: ANALYSIS AND ADAPTATION

PROJECT AIM

The aim of this project is to simulate climate adaptation in neighbourhoods and districts of cities, with a main emphasis on heat. Issues like temperature effects and surface heat balances for building facades are taken into account. The model is coupled to a meso-scale model for large scale effects of the urban heat island effect.

PROGRESS

Two manuscripts have been written and submitted for review. The project has been finished. The thesis will be defended end of 2015.

DISSERTATIONS

-

SCIENTIFIC PUBLICATIONS

-

PROJECTLEADERS

HJJ Jonker, S Kenjeres,
SR de Roode

RESEARCHTHEME

Complex dynamics of fluids

PARTICIPANTS

PJC Schrijvers, S Kenjeres,
SR de Roode, HJJ Jonker

COOPERATIONS

WUR, TNO

FUNDED

Kennis voor Klimaat	
University	-
FOM	-
STW	-
NWO Other	-
Industry	100 %
TNO	-
GTI	-
EU	-
Scholarships	-

START OF THE PROJECT

2010

INFORMATION

P Schrijvers
015 278 9174
P.J.C.Schrijvers@tudelft.nl
www.grs.citg.tudelft.nl

PROJECT LEADERS

D Crommelin (CWI), AP Siebesma,
HJJ Jonker

RESEARCH THEME

Complex dynamics of fluids

PARTICIPANTS

J Dorrestijn, D Crommelin (CWI),
F Selden (KNMI) AP Siebesma,
HJJ Jonker

COOPERATIONS

CWI, KNMI

FUNDED

NWO/ALW	
University	-
FOM	-
STW	-
NWO Other	100 %
Industry	-
TNO	-
GTI	-
EU	-
Scholarships	-

START OF THE PROJECT

2010

INFORMATION

HJJ Jonker
015 278 6157
H.J.J.Jonker@tudelft.nl
www.grs.citg.tudelft.nl

PROJECT AIM

Stochastic parameterization is an exciting new topic at the intersection of applied mathematics and climate science. In this project we will develop a stochastic approach to convection parameterization, combining new mathematical ideas on hybrid stochastic-deterministic models and multiscale systems with results from Large Eddy Simulation (LES) of atmospheric moist convection. The overall goal is to formulate a stochastic parameterization scheme that is suitable for practical use in climate models, and to evaluate the impact of such a scheme on cloud-climate feedbacks.

PROGRESS

A paper has been written about the usage of radar-data from Darwin in Australia, to construct a similar stochastic parameterization of deep convection. It is currently in press (Jesse Dorrestijn, Daan T. Crommelin, A. Pier Siebesma, Harm J.J. Jonker, and Christan Jakob. 2015 Stochastic parameterization of convective area fractions with a multcloud model inferred from observational data. Journal of the Atmospheric Sciences). Further, we are testing this parameterization of deep convection in a simplified climate model called SPEEDY. Such a model can be executed at a laptop such that it is easy to test the performance of the new parameterization. The impact of this implementation in this climate model has been analysed and a manuscript has been written. The project has been finished. The thesis will be defended second half of 2015.

DISSERTATIONS

-

SCIENTIFIC PUBLICATIONS

-

LOCAL PRECIPITATION EXTREMES DERIVED FROM NON-HYDROSTATIC MODELING

PROJECT AIM

Events of extreme precipitation are associated with flooding, erosion, and water damage and may impact transport and safety. It is commonly expected that precipitation extremes will increase as the climate warms, as a warmer atmosphere has a larger capacity for moisture. With this study, we aim to increase the understanding of underlying causes of extreme precipitation, as well as anticipate how events of extreme precipitation will react to a warming climate. To this end, observational data, as well as Large Eddy Simulations (LES) are used. Furthermore, we will explore local precipitation extremes over the Netherlands within HARMONIE, a non-hydrostatic high resolution model.

PROGRESS

Using KNMI precipitation data, the dependence of extreme precipitation to temperature and humidity has been analyzed. These results have been further assessed using a conceptual 1D model. This work is presented in "Understanding convective extreme precipitation scaling using observations and an updraft model", which has been published in the Journal of Atmospheric Sciences. We are currently in the process of using hindcasts to better understand the large scale forcings associated with extreme events. These results will be used in LES to further develop our understanding of earlier findings.

DISSERTATIONS

-

SCIENTIFIC PUBLICATIONS

-

PROJECTLEADERS

AP Siebesma

RESEARCHTHEME

Complex dynamics of fluids

PARTICIPANTS

J Loriaux, AP Siebesma,
G Lenderink, SR de Roode

COOPERATIONS

KNMI

FUNDED

Knowledge for Climate

University -

FOM -

STW -

NWO Other -

Industry 100 %

TNO -

GTI -

EU -

Scholarships -

START OF THE PROJECT

2011

INFORMATION

J Loriaux

030 220 6376

j.m.loriaux@tudelft.nl

www.grs.citg.tudelft.nl

STRATOCUMULUS CLOUDS IN A CHANGING CLIMATE

PROJECT LEADERS

SR de Roode, AP Siebesma

RESEARCH THEME

Complex dynamics of fluids

PARTICIPANTS

S dal Gesso, SR de Roode,
AP Siebesma

COOPERATIONS

KNMI, + 12 other EU partners
involved in EUCLIPSE

FUNDED

EU	
University	-
FOM	-
STW	-
NWO Other	-
Industry	-
TNO	-
GTI	-
EU	100 %
Scholarships	-

START OF THE PROJECT

2010

INFORMATION

S de Roode
S.R.deRoode@tudelft.nl
www.grs.citg.tudelft.nl/

PROJECT AIM

The cloud response due to the enhanced greenhouse effect remains the largest source of uncertainty in climate model projections of a future climate. The EU-funded Cloud Intercomparison, Process Study & Evaluation Project (EUCLIPSE) aims to reduce the uncertainty in the representation of cloud processes and feedbacks in the new generation of Earth System Models (ESMs). This sub-project will use the Dutch Atmospheric Large-Eddy Simulation model to study in detail turbulent flows in cloudy atmospheres. Central question is how the vertical atmospheric stability controls the spatial coverage and depth of low clouds like stratocumulus and shallow cumulus.

PROGRESS

Project has been finished. The thesis has been defended on March 18, 2015.

DISSERTATIONS

-

SCIENTIFIC PUBLICATIONS

-



MESOSCOPIC TRANSPORT PHENOMENA



Prof.dr.ir. AA Darhuber



Prof.dr.ir. J Snoeijer



Prof.dr.ir. J Harting

In 2006 prof. M.E.H. (Rini) van Dongen retired as head of the research group Gas Dynamics and obtained emeritus status. In 2007 prof. Anton Darhuber was appointed as his successor. On January 1, 2008 the research group Gas Dynamics was officially renamed into Mesoscopic Transport Phenomena (MTP). On January 1, 2009 the head of the group Low-Temperature Physics (LTE) prof. A.T.A.M. (Fons) de Waele retired and LTE became a part of MTP. In February 2009, Jens Harting was appointed Assistant Professor in the group MTP. His expertise rests with large-scale lattice Boltzmann simulations of suspensions and emulsions as well as micro- and meso-scale flows.

In 2013 Jens Harting was appointed part-time Professor in the group PoF at the UTwente and Jacco Snoeijer was appointed part-time Professor in the group MTP.

Research in the area of micro- and nano-fluidics comprises both fundamental and application-inspired topics ranging from fluid physics at nano-scales to manufacturing processes of optoelectronic devices. Current and commencing projects concern dip- and die-coating of chemically patterned substrates, flows driven by temperature and concentration gradients, dewetting, laser-induced flows, as well as flows involving phase changes.

Research activities of the former group LTE concern the fluid physics and technology of vortex tubes as well as flow analysis and metrology using particle image velocimetry and laser Doppler anemometry.

DENSE SUSPENSIONS IN MEDICINE AND INDUSTRY

PROJECT AIM

Colloidal particles are commonly used as stabilizers for fluid-fluid interfaces. In this project a system of colloidal particles suspended in two immiscible fluids (water and oil) is being considered. The lattice Boltzmann method is used to simulate the two fluids, while the suspended particles are simulated by molecular dynamics. A particular focus of this PhD project is on anisotropic particles such as rods, cylinders, platelets and ellipsoids, where the role of capillary and electrostatic particle-particle interactions shall be investigated.

PROGRESS

The code for Janus particles (particles with areas of different wettability) was implemented in the simulation code. Simulation studies with Janus particles were done. Furthermore the writeup of the thesis was started.

DISSERTATIONS

-

SCIENTIFIC PUBLICATIONS

1. Timescales of emulsion formation caused by anisotropic particles. F. Günther, S. Frijters, J. Harting. *Soft Matter* 10, Number 27, 4977-4989 (2014).

PROJECT LEADERS

J Harting

RESEARCH THEME

Complex dynamics of fluids

PARTICIPANTS

F Günther

COOPERATIONS

-

FUNDED

STW

University -

FOM -

STW 100 %

NWO Other -

Industry -

TNO -

GTI -

EU -

Scholarships -

START OF THE PROJECT

2010

INFORMATION

FS Günther

040 247 5140

f.s.guenther@tue.nl

TRUE SOLVENT FREE: TOWARDS THE NEXT GENERATION WATERBORNE COATINGS

PROJECT LEADERS

HP Huinink, P Venema, J Harting

RESEARCH THEME

Complex dynamics of fluids

PARTICIPANTS

M Wouters, J Harting

COOPERATIONS

-

FUNDED

DSM Coating Resins, AkzoNobel,

Océ, Drywood, STW

University -

FOM -

STW 75 %

NWO Other -

Industry 25 %

TNO -

GTI -

EU -

Scholarships -

START OF THE PROJECT

2014

INFORMATION

M Wouters

040 247 4217

M.p.j.wouters@tue.nl

www.tue.nl/universiteit/faculteiten/

[technische-natuurkunde/de-faculteit/](http://www.tue.nl/universiteit/faculteiten/technische-natuurkunde/de-faculteit/)

[medewerkers/detail/ep/e/d/](http://www.tue.nl/universiteit/faculteiten/technische-natuurkunde/de-faculteit/medewerkers/detail/ep/e/d/)

[ep-uid/20060589/](http://www.tue.nl/universiteit/faculteiten/technische-natuurkunde/de-faculteit/medewerkers/detail/ep/e/d/ep-uid/20060589/)

PROJECT AIM

The scientific aim is to understand film formation of new coatings consisting of polymer particles (acrylate based) that can be plasticized by water. The project aims to develop a simulation model that connects film drying with the chemistry of the polymer particles and the environmental conditions to enable a targeted design of waterborne coatings. Furthermore it tries to identify handles for designing fully waterborne coatings with improved performance.

PROGRESS

The literature study has been started, as well as the first simulations with a simulation code which combines the lattice Boltzmann method (LBM) with the immersed boundary method (IBM).

DISSERTATIONS

-

SCIENTIFIC PUBLICATIONS

-

DEWETTING OF THIN LIQUID FILMS ON PARTIALLY WETTING SURFACES

PROJECT AIM

The aim of this project is to study the physics of dewetting of thin liquid layers on partially wetting surfaces. The evaporation of these films causes technological difficulties, as cooling due to the large latent heat of evaporation of water leads to inhomogeneous thermal contractions of substrates. At the focus is the question whether the dewetting and break-up process of the water layer into droplets can be influenced regarding the size distribution and arrangement of the resulting droplets.

PROGRESS

A numerical model for the dynamics of spontaneous and induced break-up of model liquids has been developed. An experimental setup for dry-spot nucleation induced by an air-jet has been built and systematic experiments have been performed. A second setup for temperature-gradient-induced dry-spot nucleation has been designed and built and is currently being used for a systematic study. A third setup for moving airjets has been designed and built. A complete study of the influence of all relevant parameters on the deformation of the thin liquid film and the resulting break-up behavior and residual droplet distributions has been performed.

DISSERTATIONS

-

SCIENTIFIC PUBLICATIONS

1. C W J Berendsen, E M van Veldhuizen, G M W Kroesen and A A Darhuber, Marangoni flows induced by atmospheric-pressure plasma jets, *J. Phys. D: Appl. Phys.* 48 (2015) 025203.
2. H. M. J. M. Wedershoven, C.W. J. Berendsen, J. C. H. Zeegers, and A. A. Darhuber, Infrared-Laser-Induced Thermocapillary Deformation and Destabilization of Thin Liquid Films on Moving Substrates, *PHYSICAL REVIEW APPLIED* 3, 024005 (2015).

PROJECTLEADERS

AA Darhuber, JCH Zeegers

RESEARCHTHEME

Complex dynamics of fluids

PARTICIPANTS

C Berendsen, J Zeegers,
AA Darhuber

COOPERATIONS

ASML

FUNDED

FOM-IPP met ASML en Oce
University -
FOM 50 %
STW -
NWO Other -
Industry 50 %
TNO -
GTI -
EU -
Scholarships -

START OF THE PROJECT

2010

INFORMATION

AA Darhuber
a.a.darhuber@tue.nl

ACTIVE CONTROL OF SOLUTION PROCESSING OF ORGANIC ELECTRONIC DEVICES

PROJECT LEADERS

AA Darhuber, J Harting, JCH Zeegers

RESEARCH THEME

Complex dynamics of fluids

PARTICIPANTS

Q Xie, B Wedershoven, J Zeegers, J Harting, AA Darhuber

COOPERATIONS

-

FUNDED

STW	
University	-
FOM	-
STW	100 %
NWO Other	-
Industry	-
TNO	-
GTI	-
EU	-
Scholarships	-

START OF THE PROJECT

2014

INFORMATION

AA Darhuber
a.a.darhuber@tue.nl

PROJECT AIM

This project aims at generating insight into and implementing control of evaporative deposition processes in the context of organic electronics manufacturing. Quantitative experiments and computer simulation will be combined to develop a validated process simulation tool. This tool will be used to develop and test strategies for the active control of the deposition process and the elimination of layer non-uniformities. Control strategies include for instance laser induced non-uniform temperature distributions.

PROGRESS

Quantitative experiments regarding infrared laser manipulation of thin liquid films of pure liquids on completely and partially wetting substrates have been performed. The results could be reproduced quantitatively by numerical model calculations. Regarding the development of large scale lattice-Boltzmann simulations, the following milestones were achieved:

1. Implementation of heat transfer model for single-component fluids;
2. A charge transport model is developed for single-component fluids (with static charged colloid) and multi-component fluids;
3. Evaporation model of drying droplet with/without colloidal suspension; reproduced coffee-ring stain effect and rush-hour phenomena.

DISSERTATIONS

-

SCIENTIFIC PUBLICATIONS

1. H. M. J. M. Wedershoven, C.W. J. Berendsen, J. C. H. Zeegers, and A. A. Darhuber. Infrared-Laser-Induced Thermocapillary Deformation and Destabilization of Thin Liquid Films on Moving Substrates. PHYSICAL REVIEW APPLIED 3, 024005 (2015).



VORTEX DYNAMICS AND TURBULENCE



Prof.dr. HJH Clercx



Prof.dr.ir. GJF van Heijst



Prof.dr. F Toschi



Prof.dr.ir. BJ Geurts

The research in this section concerns transport phenomena, in particular as occurring in turbulent flows. An important line of approach is that vortex dynamics, in which elementary processes are studied in rather isolated configurations. Special attention is given to the influence of body forces associated with background rotation and density stratification. Such situations are met in industrial settings and also within the framework of geophysical fluid dynamics. In addition to transport in turbulent flows, the dynamics of granular media and 3D viscous mixing is studied.

The following main lines of research can be distinguished:

1. Spectral and transport properties of 3D turbulence
2. Dispersion in quasi-2D turbulence
3. Atmospheric physics
4. Granular media and viscous mixing

In most of these themes the research approach is a combination of laboratory experiments, numerical simulation, and theoretical modelling.

PHOTO-BIOREACTORS: SAVING ALGAE FROM TURBULENCE

PROJECT AIM

The aim of the present project is to investigate numerically and develop models for the statistical properties of hydrodynamics stresses on algae in turbulent environments at different cell concentrations. In the recent past the small-scale statistical properties of (point-wise) particles in turbulence, like their acceleration, have been investigated experimentally and numerically. Numerical methods have been developed and employed to study the rheological properties of very dense suspensions of cells in simple laminar flows. Here we will need to combine the physics and the numerical methods of these previous studies and push both considerably further to challenge the turbulence transport and the statistical properties of (non)-Newtonian dense cell suspensions.

PROGRESS

1. Implementation particle-fluid interaction modeled by mid-point bounce back scheme with no fluid inside particle.
2. Implementation of short-range repulsion forces and lubrication forces for particle-particle interaction.
3. Validation tests for particle-fluid interaction including Jeffrey orbits, particle settling under gravity and effective viscosity test.
4. Development of numerical setup for bubble column simulations in collaboration with University of Almeria, Spain.

DISSERTATIONS

-

SCIENTIFIC PUBLICATIONS

-

PROJECT LEADERS

F Toschi, HJH Clercx

RESEARCH THEME

Complex Dynamics of Fluids

PARTICIPANTS

A Gupta, F Toschi, HJH Clercx

COOPERATIONS

Shell-NWO/FOM, Univ. of Almeria, Spain.

FUNDED

Shell-NWO/FOM

University	-
FOM	100 %
STW	-
NWO Other	-
Industry	-
TNO	-
GTI	-
EU	-
Scholarships	-

START OF THE PROJECT

2013

INFORMATION

F Toschi

040 247 3911

f.toschi@tue.nl

www.phys.tue.nl/wdy/

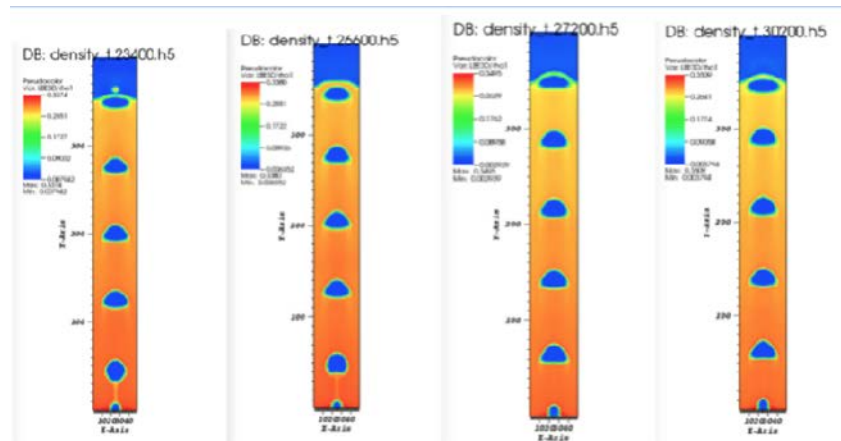

Density Profile with Shan Chen multicomponent simulations at various time steps . $p_1 = 0.27$, $p_2 = 0.025$, $\tau = 0.55$, $G_{12} = 0.86$. System size is $400 \times 50 \times 1$. $g = -0.0001$.

LAGRANGIAN MIXING ANALYSIS OF HEAT TRANSFER: A NEW WAY FOR THERMAL OPTIMISATION

PROJECT LEADERS

HJH Clercx

RESEARCH THEME

Complex dynamics of fluids

PARTICIPANTS

O Baskan, HJH Clercx

COOPERATIONS

MFM Speetjens (TU/e-Wbt),
EA Demissie (TU/e-Wbt),
G Metcalfe (CSIRO, Australia)

FUNDED

STW
University -
FOM -
STW 100 %
NWO Other -
Industry -
TNO -
GTI -
EU -
Scholarships -

START OF THE PROJECT

2010

INFORMATION

HJH Clercx
040 247 2680
h.j.h.clercx@tue.nl
www.phys.tue.nl/wdy/

PROJECT AIM

The objective is in-depth analysis of the Kenics static mixer by Lagrangian mixing analysis of heat transfer. The study is divided into two subprojects: Topological mixing analysis of heat transfer in the Kenics mixer (E. Demissie; Wbt) and Experimental heat-transfer and mixing analysis of the Kenics mixer (O. Baskan, Applied Phys.). The latter subproject focuses on experimental characterization of Lagrangian mixing properties in case studies by measurement of 3D fluid trajectories and evolution of 3D scalar fields using advanced optical measurement techniques. Benchmarking of numerical thermal mixing analyses and testing of the prototype thermal-analysis tools for advanced data processing.

PROGRESS

This project has been finished with the thesis of O. Baskan (2015).

DISSERTATIONS

1. Baskan, O. (2015). Advective-diffusive scalar transport in laminar periodic flows : an experimental investigation. Eindhoven: Technische Universiteit Eindhoven. ((Co-)promot.: prof.dr. H.J.H. Clercx & dr.ir. M.F.M. Speetjens).

SCIENTIFIC PUBLICATIONS

1. Baskan, O., Speetjens, M.F.M., Metcalfe, G. & Clercx, H.J.H. (2015). Experimental and computational study of scalar modes in a periodic laminar flow. *International Journal of Thermal Sciences*, 96, 102-118.
2. Baskan, O., Speetjens, M.F.M., Metcalfe, G. & Clercx, H.J.H. (2015). Direct experimental visualization of the global Hamiltonian progression of two-dimensional Lagrangian flow topologies from integrable to chaotic state. *Chaos*, 25:103106.

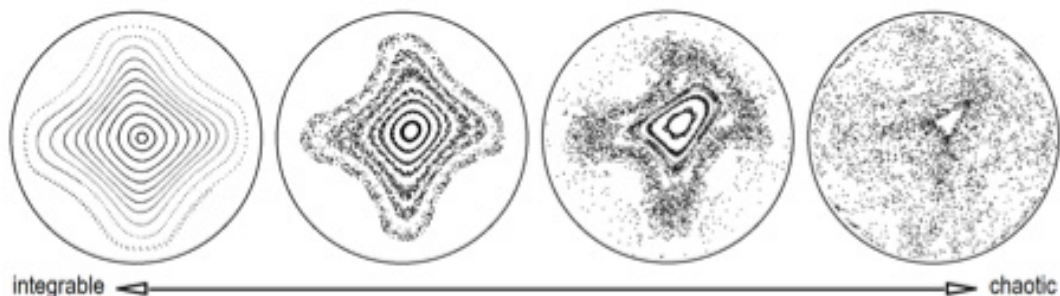

Directly measured Poincaré maps. The maps show Hamiltonian progression of the Lagrangian flow topology of the 2D time-periodic RAM

ROTATING RAYLEIGH BÉNARD EXPERIMENTS: TUNING THE TRANSITION BETWEEN TURBULENT STATES

PROJECT AIM

Rayleigh-Bénard convection (RBC) is the laboratory realization of buoyancy-driven convection, which is relevant to many natural phenomena and industrial applications. Since these processes are often coupled with system rotation, its effect on RBC is also of interest. In general, depending on the system parameters, the Rayleigh-Bénard system can exist in multiple turbulent states with different heat transfer characteristics. The aim of this project is to explore the possibility of tuning the transitions between various turbulent regimes, and/or controlling the heat transfer, in rotating RBC by adding particles to the fluid or changing boundary conditions.

PROGRESS

1. After finalizing the density segregation method for extracting particles in a narrow density range, we invested time to produce enough particles (~150 gm) for the planned experiments.

2. Experiments with particle injections were performed, and data recorded at different rotation rates.

3. The injected particles form layers on the horizontal heat transfer surfaces, decreasing the heat transfer. This decrease in the heat flux is due to the inability of the layers to respond quickly enough to the heat flux demanded by the convecting fluid.

4. However, at high rotation rates, the convection becomes 'slower', and the particle layer then is able to respond better to the heat flux requirements of the fluid, improving the heat transfer in relation to the non-rotating condition.

5. The above results are being consolidated in the form of a journal publication.

DISSERTATIONS

-

SCIENTIFIC PUBLICATIONS

-

PROJECT LEADERS

HJH Clercx, F Toschi

RESEARCH THEME

Complex dynamics of fluids

PARTICIPANTS

PR Joshi, HJH Clercx, F Toschi,
RPJ Kunnen, KMJ Alards, H Rajaei

COOPERATIONS

G Ahlers (UCSB), B Geurts (UT),
D Lohse (UT), R Verzicco (Roma)

FUNDED

FOM	
University	-
FOM	100 %
STW	-
NWO Other	-
Industry	-
TNO	-
GTI	-
EU	-
Scholarships	-

START OF THE PROJECT

2014

INFORMATION

HJH Clercx
040 247 2680
h.j.h.clercx@tue.nl

RPJ Kunnen
040 247 3194
r.p.j.kunnen@tue.nl
www.phys.tue.nl/wdy

Schematic of the Rayleigh-Bénard cell: (a) side view; (b) top view. CW: cooling water; CP: copper plates; TS: temperature sensors; SW: side walls; SH: secondary heaters; AS: adiabatic shields; RH: Resistance heaters; BT: Bleed tube for deaeration; IT: Tube for particle injection.

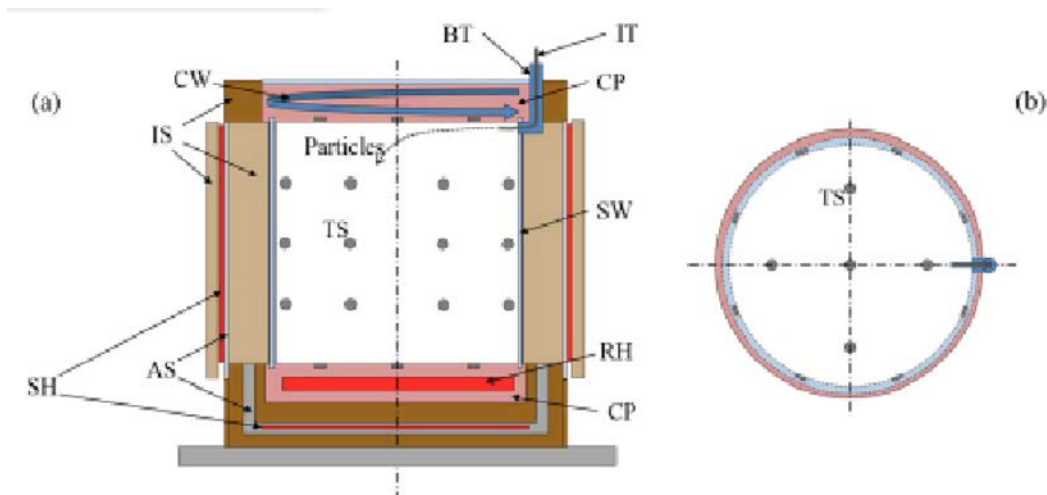

PROJECT LEADERS

HJH Clercx

RESEARCH THEME

Complex dynamics of fluids

PARTICIPANTS

SJ Kaptein, M Duran Matute, HJH Clercx

COOPERATIONS

M Blaas (Deltares, Utrecht),
J Pietrzak (TU Delft),
V Armenio (University of Trieste)

FUNDED

STW
University -
FOM -
STW 100 %
NWO Other -
Industry -
TNO -
GTI -
EU -
Scholarships -

START OF THE PROJECT

2014

INFORMATION

HJH Clercx
040 247 2680
h.j.h.clercx@tue.nl
www.phys.tue.nl/wdy/

PROJECT AIM

The aim of the project is to use DNS (Direct Numerical Simulation) and LES (Large Eddy Simulations) to explore the role of tidal straining on the mixing-stratifying competition. It is also an objective to improve turbulent closures for application in Delft3D (Deltares) using simulation results and field data (made available by the Port of Rotterdam), which specifically take into account anisotropy due to inhomogeneous horizontal and vertical conditions.

PROGRESS

During the second year of the PhD, a complex simulation case has been defined: a horizontal density gradient to model the river outflow interacting with an oscillating pressure gradient modeling the tide. Several grids have been tested and the results of the oscillating pressure gradient have been compared with experimental data. A mathematical model has been set up for the horizontal background density that still allows the application of periodic boundary conditions. Steps have been successfully undertaken to optimize the parallel efficiency and to find resources for the computations.

DISSERTATIONS

-

SCIENTIFIC PUBLICATIONS

-

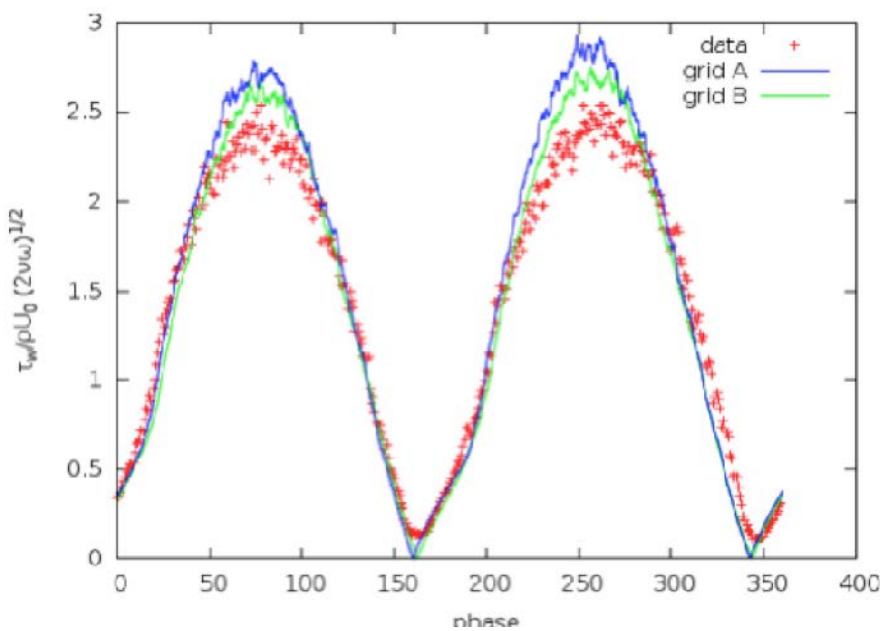

A NEW WAY OF UNDERSTANDING CHAOTIC WIND BURSTING AT NIGHT

PROJECT AIM

The project aims to find the physical mechanism that drives intermittent (discontinuous) turbulence in the nocturnal atmospheric boundary layer. During intermittency, periods with 'laminar' flow are interrupted by chaotic bursts of turbulence and a significant transport of heat, moisture and momentum occurs. Key tools are theoretical analyses combined with Direct Numerical Simulation (DNS) techniques.

PROGRESS

This project has been finished with the thesis of J.M.M. Donda (2015).

DISSERTATIONS

1. Donda, J.M.M. (2015). Collapse of turbulence in the nocturnal atmospheric boundary layer. Eindhoven: Technische Universiteit Eindhoven. ((Co-)promot.: prof.dr. H.J.H. Clercx, prof.dr.ir. G.J.F. van Heijst & dr.ir. B.J.H. van de Wiel).

SCIENTIFIC PUBLICATIONS

1. Donda, J.M.M., Hooijdonk, I.G.S. van, Moene, A.F., Jonker, H.J.J., Heijst, G.J.F. van, Clercx, H.J.H. & Wiel, B.J.H. van de (2015). Collapse of turbulence in stably stratified channel flow : a transient phenomenon. Quarterly Journal of the Royal Meteorological Society, 141(691), 2137-2147.
2. van Hooijdonk I, Donda J, Clercx H, Bosveld F, van de Wiel B (2015) Shear Capacity as Prognostic for Nocturnal Boundary Layer Regimes. J Atmos Sci 72(4):1518-1532, DOI 10.1175/JAS-D-14-0140.1.

PROJECTLEADERS

BJH van de Wiel , HJH Clercx,
GJF van Heijst

RESEARCHTHEME

Complex dynamics of fluids

PARTICIPANTS

JMM Donda, BJH van de Wiel,
IGS van Hooijdonk,
HJH Clercx, GJF van Heijst

COOPERATIONS

A Moene (WUR), H Jonker (TUD),
P Baas (KNMI)

FUNDED

Vidi NWO-ALW
University -
FOM -
STW -
NWO Other 100 %
Industry -
TNO -
GTI -
EU -
Scholarships -

START OF THE PROJECT

2010

INFORMATION

HJH Clercx
040 247 2680
h.j.h.clercx@tue.nl

ROTATING RB TURBULENCE: EXPERIMENTS

PROJECT LEADERS

HJH Clercx

RESEARCH THEME

Complex dynamics of fluids

PARTICIPANTS

H Rajaei, HJH Clercx, RPJ Kunnen,
F Toschi, KMJ Alards, PR Joshi

COOPERATIONS

-

FUNDED

FOM

University -

FOM 100 %

STW -

NWO Other -

Industry -

TNO -

GTI -

EU -

Scholarships -

START OF THE PROJECT

2013

INFORMATION

HJH Clercx

040 247 2680

h.j.h.clercx@tue.nl

www.phys.tue.nl/wdy/

PROJECT AIM

This project focusses on exploring with 3D Particle Tracking Velocimetry (3D-PTV) how the Lagrangian dynamics of (fluid) particles can be utilized for turbulent state characterization, how the flow transition from one state to the other in rotating convection will affect the Lagrangian statistics of (fluid) particles, and how particle and thermal inertia affect particle dynamics in (rotating) convection.

PROGRESS

We mainly focus on the analysis of the 3D-PTV and simulations data for different rotation rates at the cell center and close to the top plate. Using the first measurements of Lagrangian acceleration and accompanying direct numerical simulations in turbulent rotating convection, we show that the transition between turbulent states in rotating turbulent convection is a boundary-layer transition between Prandtl-Blasius type (typical of non-rotating convection) and Ekman type. Currently, we are working on the effects of rotation on large and small scales isotropy for rotating turbulent convection. It is found that background rotation enhances large-scale anisotropy at the cell center and close to the top plate, while decreases it at intermediate height. The large-scale anisotropy, induced by rotation, has negligible effect on the small scales at the cell center, whereas the small scales remain anisotropic close to the top plate.

DISSERTATIONS

-

SCIENTIFIC PUBLICATIONS

-

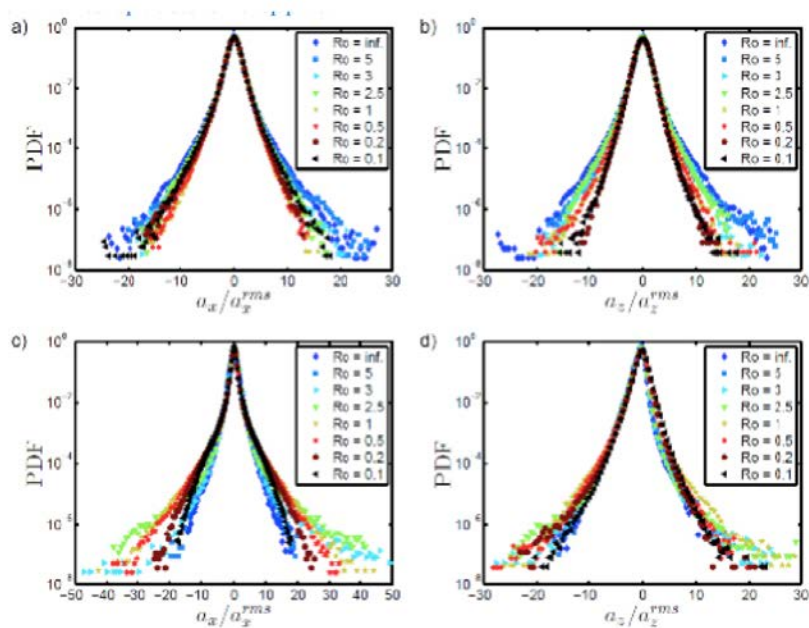

Normalized acceleration PDFs from experiments: (a) horizontal at the center, (b) vertical at the center, (c) horizontal near top (larger horizontal axis range compared to other PDFs), and (d) vertical near top.

HOW GRAVITY, SHEAR AND COALESCENCE MODIFY THE DROPLET SIZE DISTRIBUTION

PROJECT AIM

The goal is to address the basic phenomenology of droplets under realistic situations, the focus being on large-scale behavior. In this study the focus will be on the effects of gravity and of shear on droplet transport and collision rates.

PROGRESS

Simulations have been finished for both heavy particles in shear turbulence and more neutral buoyant particles in homogeneous isotropic turbulence. Both studies will result in a paper. The paper about heavy particles is finished and ready to be submitted. For the paper about more neutral buoyant particles a first draft version is finished. The finalization of the thesis is in the last stage. Furthermore, two collaborations will result in a paper. One with the group from Luca Biferale about particles in a rotating flow. The other paper involves Neutral and inertial particle acceleration in non isotropic turbulent flows, like shear turbulence.

DISSERTATIONS

-

SCIENTIFIC PUBLICATIONS

1. De Pietro, M., Hinsberg, M.A.T. van, Biferale, L., Clercx, H.J.H., Perlekar, P. & Toschi, F. (2015). Clustering of vertically constrained passive particles in homogeneous isotropic turbulence. *Physical Review E*, 91(5), 053002-1/7.

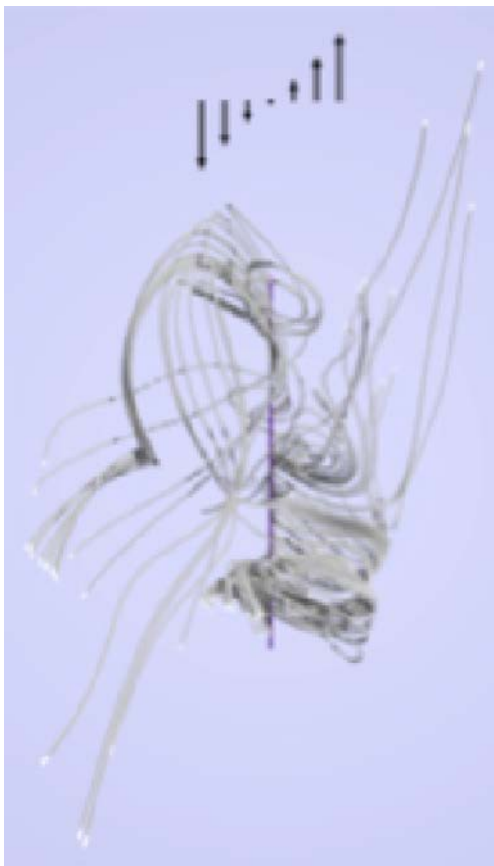

The advection of tracers in a homogeneous shear flow

PROJECTLEADERS

F Toschi, HJH Clercx, GJF van Heijst

RESEARCHTHEME

Complex dynamics of fluids

PARTICIPANTS

MAT van Hinsberg, HJH Clercx,
F Toschi

COOPERATIONS

L Biferale (Rome, Italy), P Perlekar
(TIFR, Hyderabad, India),
J ten Thije Boonkkamp (W&I-TU/e)
A. Gylfason (Reykjavik, Iceland)
Chung-Min Lee (California, USA)

FUNDED

FOM	
University	-
FOM	100 %
STW	-
NWO Other	-
Industry	-
TNO	-
GTI	-
EU	-
Scholarships	-

START OF THE PROJECT

2011

INFORMATION

HJH Clercx
040 247 2680
h.j.h.clercx@tue.nl

F Toschi
040 247 3911
f.toschi@tue.nl
www.phys.tue.nl/wdy/

TURBULENCE AND ZONAL FLOWS IN TOKAMAK PLASMAS

PROJECT LEADERS

HJH Clercx, GJF van Heijst

RESEARCH THEME

Complex dynamics of fluids

PARTICIPANTS

VH Fernandes, LPJ Kamp,
GJF van Heijst, HJH Clercx

COOPERATIONS

N Lopes Cardozo (TU/e-TN),
R Jaspers (TU/e-TN),
M de Baar (FOM; TU/e-Wbt)
M Lauret (TU/e-Wtb)

FUNDED

TU/e	
University	100 %
FOM	-
STW	-
NWO Other	-
Industry	-
TNO	-
GTI	-
EU	-
Scholarships	-

START OF THE PROJECT

2010

INFORMATION

HJH Clercx, 040 247 2680
h.j.h.clercx@tue.nl

LPJ Kamp, 040 247 4292
l.p.j.kamp@tue.nl
www.phys.tue.nl/wdy/

PROJECT AIM

Large-scale coherent flows play an important role both in geophysical fluids and in fusion plasmas since they interact with the turbulence and can give rise to transport barriers. With relatively simple fluid dynamics experiments in combination with numerical simulations we study how zonal flows affect turbulence and turbulent transport. In this project visualisation of the effect of flow on turbulence is a key element, whereas the fluid dynamics experiment will also serve as a test bed for control methods (link with project "Control of plasma transport by plasma flow" which is being conducted at Dept. Mech. Engineering, TU/e).

PROGRESS

We are in the process of finalizing the PhD-thesis and writing several papers related to the results of this project.

DISSERTATIONS

-

SCIENTIFIC PUBLICATIONS

-

STICK TO THE SURFACE!

PROJECT AIM

Main aim is the development of numerical tools to characterize transport of particle debris under combined effects of fluid dynamics and plasma physics. Our aim is to study when and how particles are released from surfaces under the conditions present in EUV lithography tool (hydrodynamic and rarefied gas flows, in presence of harsh and weak plasma environment). This will lead to a clear picture of what occurs inside the tool's plasma and main chambers and how it is possible to influence and, in perspective, prevent potential damaging dust to be released from surfaces.

PROGRESS

The comprehension of the dynamics of non-equilibrium flows, characterized by finite Kn number, and the mathematical treatment of those has significantly advanced. This allowed to develop a new kinetic coupling scheme between Lattice Boltzmann Method (LBM) and Direct Simulation Monte Carlo (DSMC) in order to study flows with variable rarefaction conditions. In particular, taking advantage of the Grad's moments method to expand the single particle probability distribution function as a series in Hermite polynomials and of the Gauss-Hermite quadrature technique, a precise coupling has been achieved. The new approach has been tested and validated against simple flows such as Poiseuille and Couette flows up to $Kn=0.25$. The extension of such approach to more complex flow configurations has already started.

DISSERTATIONS

-

SCIENTIFIC PUBLICATIONS

-

Top view of single particle distribution function as a function of the molecular speed components, ξ_x and ξ_y (2D case), for a Poiseuille flow and a cell in proximity of the wall. The black dots represent the discrete velocities stencil where the distribution is evaluated for the coupling scheme.

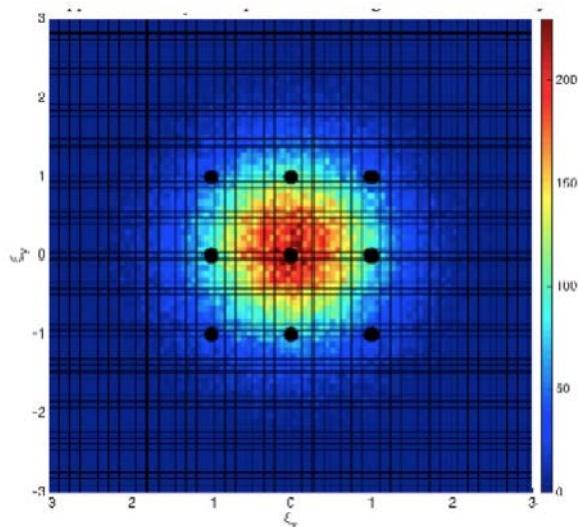

PROJECTLEADERS

HJH Clercx, F Toschi

RESEARCHTHEME

Complex dynamics of fluids

PARTICIPANTS

G Di Staso, J van Dijk, S Nijdam,
GMW Kroesen, F Toschi,
HJH Clercx

COOPERATIONS

ASML

FUNDED

STW
University -
FOM -
STW 100 %
NWO Other -
Industry -
TNO -
GTI -
EU -
Scholarships -

START OF THE PROJECT

2014

INFORMATION

HJH Clercx
040 247 2680
h.j.h.clercx@tue.nl

F Toschi
040 247 3911
f.toschi@tue.nl
www.phys.tue.nl/wdy/

COMPLEX FLOWS AND COMPLEX FLUIDS

PROJECT LEADERS

F Toschi, L Biferale (Tor Vergata, Italy)

RESEARCH THEME

Complex dynamics of fluids

PARTICIPANTS

R Scatamacchia, F Toschi

COOPERATIONS

L Biferale (Tor Vergata, Italy),
AS Lanotte (ISAC, SNR),
M Sbragaglia (Tor Vergata, Italy)

FUNDED

University of Tor Vergata
University 100 %
FOM -
STW -
NWO Other -
Industry -
TNO -
GTI -
EU -
Scholarships -

START OF THE PROJECT

2012

INFORMATION

F Toschi
040 247 3911
f.toschi@tue.nl
www.phys.tue.nl/wdy/

PROJECT AIM

The project is a dual-degree collaboration between TU/e and University of Tor Vergata (Italy). The goal of the project is to study the behavior of few prototypical examples of complex flows and complex fluids.

PROGRESS

This project has been finished with the thesis of R. Scatamacchia (2015).

DISSERTATIONS

1. Scatamacchia, R. (2015). Fluctuations in hydrodynamics at large and small scales. Eindhoven: Technische Universiteit Eindhoven. ((Co-)promot.: prof.dr. F. Toschi, prof. L. Biferale & M. Sbragaglia.

SCIENTIFIC PUBLICATIONS

-

UNRAVELLING 3D MIXING NEAR THE SURFACE OF ACTUATED BEADS

PROJECT AIM

This project focuses on magneto-active mixing and catching by small beads for microfluidic biosensor applications. It concerns the full exploitation of the scavenging properties of magnetic beads in microfluidic devices, control of fluid mixing, and the enhancement of the capture of (biological) targets by the beads. Key in this process is knowledge of the unsteady streamline pattern around a translating and rotating sphere and a detailed understanding of the local mixing properties nearby the sphere surface by laboratory experiments and numerical modelling. Actuation protocols will be devised to enhance the capture probability of target particles by the bead.

PROGRESS

The laboratory experiments and subsequent analysis of particle tracking data has been completed and the concept thesis had been written. The defense is planned for June 2016.

DISSERTATIONS

-

SCIENTIFIC PUBLICATIONS

-

PROJECTLEADERS

HJH Clercx

RESEARCHTHEME

Complex dynamics of fluids

PARTICIPANTS

NR Moharana, RR Trieling,
GJF van Heijst, HJH Clercx

COOPERATIONS

M Prins (TU/e-TN; Philips),
AM de Jong (TU/e-TN),
J den Toonder (TU/e-Wbt; Philips),
MFM Speetjens (TU/e-Wbt).

FUNDED

STW	
University	-
FOM	-
STW	100 %
NWO Other	-
Industry	-
TNO	-
GTI	-
EU	-
Scholarships	-

START OF THE PROJECT

2010

INFORMATION

HJH Clercx
040 247 2680
h.j.h.clercx@tue.nl
www.phys.tue.nl/wdy/

EXPERIMENTAL STUDY OF THE DYNAMICS OF DROPLETS IN TURBULENT SPRAYS AND CLOUDS

PROJECT LEADERS

HJH Clercx, GJF van Heijst

RESEARCH THEME

Complex dynamics of fluids

PARTICIPANTS

DD van der Voort, HJH Clercx,
GJF van Heijst, RPJ Kunnen,
W van de Water

COOPERATIONS

N Maes (TU/e-Wtb), NJ Dam (TU/e-Wtb)

FUNDED

FOM	-
University	-
FOM	100 %
STW	-
NWO Other	-
Industry	-
TNO	-
GTI	-
EU	-
Scholarships	-

START OF THE PROJECT

2013

INFORMATION

GJF van Heijst
040 247 2722
g.j.f.v.heijst@tue.nl
www.phys.tue.nl/wdy/

PROJECT AIM

The main aims are 1) to experimentally investigate the breakup of turbulent jets and sprays by means of phosphorescence, 2) to study the behavior of individual droplets in turbulent sprays and in zero-mean homogeneous isotropic turbulence by Lagrangian measurements, and 3) to explore droplet dispersion in these systems.

PROGRESS

The evaporation of sprays has been investigated using laser-induced phosphorescence (LIP), interferometric particle imaging. To further study the effects on individual droplets an acoustic levitator was build, and evaporating single droplets have been investigated through phosphorescence measurements and diffuse-background illumination imaging. The influence of cavitation, gas bubbles, on the dispersion of sprays was investigated through use of a glass nozzle to investigate the phenomenon, and to correlate it with measured pressure pulses through the system. These pressure pulses were then used to correlate the cavitation event to measurements of sheet-excited LIP measurements to obtain their dispersion. To investigate the influence of spray-induced turbulence on the droplets dispersion, and IR-PIV experiment was set up and tested with the use of anti-stokes particles as tracers, to avoid visualizing the liquid spray.

DISSERTATIONS

-

SCIENTIFIC PUBLICATIONS

1. D.D. van der Voort, W. van de Water, N. Dam, H.J.H. Clercx, G.J.F. van Heijst, "Breakup and dispersion of glowing sprays", Proceedings of the 13th Triennial International Conference on Liquid Atomization and Spray Systems, 2015.

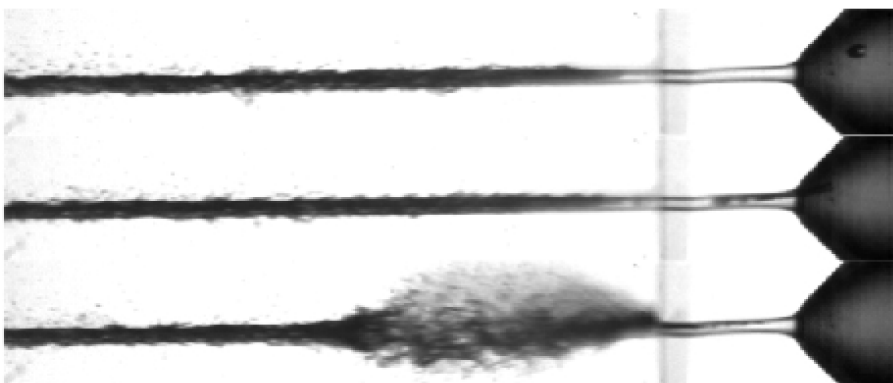

The influence of cavitation (gas bubbles) on spray breakup shown through diffuse-backlight illumination through a glass nozzle. The 200 micrometer bubble is deformed, forming a gas layer between the wall and the fluid, increasing the velocity, asymmetry, and dispersion of the spray. This event is accompanied by a pressure pulse as the bubble collapses against the wall.

HPC FOR LAGRANGIAN/EULERIAN TURBULENCE, MICRO- AND NANO-FLUIDIC

PROJECT AIM

Implementation of novel algorithms and/or optimization of existing fully parallel and scalable algorithms to study thermal flows at macro-scales and/or fluctuating hydrodynamics at micro and nano-scales. If the opportunity arises, exploration of the coupling with finite size particles (with and/or without internal dynamics).

PROGRESS

Implemented optimised random number generator for fluctuating lattice Boltzmann methods (FLBM). Use Shan-Chen model and MRT for robustness test of fluctuating lattice Boltzmann.

DISSERTATIONS

-

SCIENTIFIC PUBLICATIONS

-

PROJECT LEADERS

F Toschi

RESEARCH THEME

Complex dynamics of fluids

PARTICIPANTS

X Xue, F Toschi, M Sbragaglia (Rome), L. Biferale (Rome)

COOPERATIONS

University of Rome, Tor Vergata, HPC-LEAP Program, Eurotech

FUNDED

HPC-LEAP (Marie Curie Fellowship), Horizon 2020

University -

FOM -

STW -

NWO Other -

Industry -

TNO -

GTI -

EU 100 %

Scholarships -

START OF THE PROJECT

2015

INFORMATION

F Toschi

040 247 3911

f.toschi@tue.nl

www.phys.tue.nl/wdy

EARTHQUAKE DYNAMICS: UNDERSTANDING THEIR PHYSICS FROM MODELING SOFT- GLASSY MATERIALS

PROJECT LEADERS

F Toschi, J Trampert

RESEARCH THEME

Complex dynamics of fluids

PARTICIPANTS

PP Kumar, F Toschi, J Trampert,
R Benzi (Rome)

COOPERATIONS

Shell-NWO/FOM

FUNDED

Shell-NWO/FOM

University	-
FOM	100 %
STW	-
NWO Other	-
Industry	-
TNO	-
GTI	-
EU	-
Scholarships	-

START OF THE PROJECT

2015

INFORMATION

F Toschi
040 247 3911
f.toschi@tue.nl
www.phys.tue.nl/wdy/

PROJECT AIM

The aim of the project is to develop a quantitative connection between the physics of complex soft-glassy materials below yield stress and the dynamics of stick-slip faulting events leading to earthquakes. A novel formulation based on the multicomponent Lattice Boltzmann method is used to investigate fundamental issues related to natural seismicity, to find the interaction between spatially and temporally separated faulting events, as well as to determining the response of faults to external perturbations (i.e. induced seismicity) mimicking natural gas extraction and activities in injection wells. This earthquake model will then be fine-tuned using inversion of surface seismic recordings.

PROGRESS

1. Literature review and specialized training in lattice Boltzmann methods for complex fluids, completed. Also training on statistical physics and seismology.
2. Finished implementation and validation of a highly optimized multi-GPU code to simulate sheared emulsions leading to plastic events.
3. Developed data reduction tools to capture the topology of droplets precisely, benchmarked that to a Voronoi based approach. It will be used to track the topological dislocations in the sheared droplets.

DISSERTATIONS

-

SCIENTIFIC PUBLICATIONS

-

The interface (droplet topology) tracking algorithm in action, just before a plastic event is

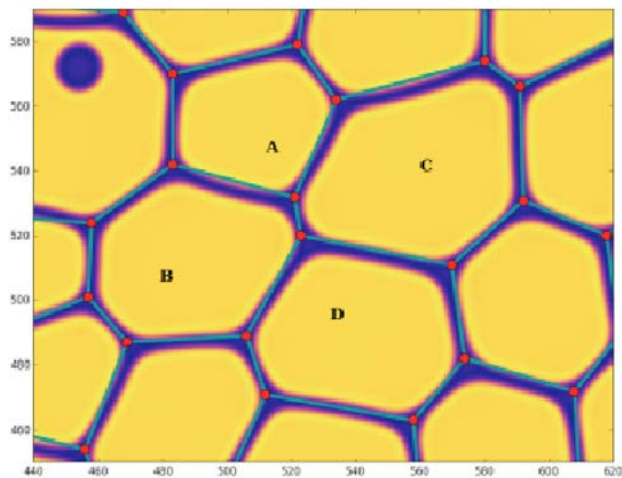

THE EFFECTS OF BAROTROPIC VORTICES ON SEDIMENT TRANSPORT: AN EXPERIMENTAL AND NUMERICAL STUDY

PROJECT AIM

Understand the underlying physics and improve the modeling of how barotropic vortices and sediment interact.

PROGRESS

We have performed laboratory experiments where a 2 cm thick bed of polystyrene particles under water is subjected to full or partial spin-down inside a cylinder. This generates a swirl flow that transports the particles towards the center of the cylinder and modifies the particle bed. We have systematically explored the parameter space. The bed thickness is measured using a light attenuation technique allowing us to quantify the sediment transport. Simultaneously, we are using a finite difference code in cylindrical coordinates to simulate the advection of particles as a passive tracer. Different boundary and initial conditions have been tested in order to compare the results with the laboratory experiments.

DISSERTATIONS

-

SCIENTIFIC PUBLICATIONS

-

PROJECTLEADERS

GJF van Heijst, M Duran Matute

RESEARCHTHEME

Complex dynamics of fluids

PARTICIPANTS

AS Gonzalez Vera, M Duran Matute

COOPERATIONS

R Verzicco (UT)

FUNDED

CONACYT (Mexico)

University -

FOM -

STW -

NWO Other -

Industry -

TNO -

GTI -

EU -

Scholarships 100 %

START OF THE PROJECT

2015

INFORMATION

GJF van Heijst

040 247 2722

g.j.f.v.heijst@tue.nl

www.phys.tue.nl/wdy/

PROJECT LEADERS

F Toschi

RESEARCH THEME

Complex dynamics of fluids

PARTICIPANTS

MFP ten Eikelder, RMJ Jeurissen,
F Toschi, J ten Thije Boonkamp
(W&I-TU/e)

COOPERATIONS

X Li, D Lohse, JH Snoeijer (UT),
A van der Bos, M van der Berg, H
Reinten, M Versluis, H Wijshoff (Océ
Technologies B.V.)

FUNDED

STW, Océ Technologies B.V.
University -
FOM -
STW 100 %
NWO Other -
Industry -
TNO -
GTI -
EU -
Scholarships -

START OF THE PROJECT

2015

INFORMATION

F Toschi
040 247 3911
f.toschi@tue.nl
www.phys.tue.nl/wdy/

PROJECT AIM

In this project we will perform a systematic experimental and numerical investigation of the occurrence of the directional jetting instability and of its dependence on the different parameters that control the dynamics of the jetting nozzle. The goal of understanding the mechanisms of the instability is to find methods to prevent it.

PROGRESS

The numerical PhD student started at the end of 2015 and is currently studying the relevant literature and starting with the first simulations. The experiment PhD student did not start yet.

DISSERTATIONS

-

SCIENTIFIC PUBLICATIONS

-

DYNAMICS, COLLISIONS AND COALESCENCE OF DROPLETS IN TURBULENCE

PROJECT AIM

In this experimental project the motion of droplets with diameter of 10 to 50 micrometer in an air-filled turbulence chamber are tracked with 3D particle tracking velocimetry (PTV). The focus is on interactions between droplets (collision or coalescence) and the effect of gravity. Turbulence-induced droplet clustering is the process responsible for rapid precipitation formation; it is, however, not well understood.

PROGRESS

The flow in the turbulence chamber has been fully characterized with PIV. The size distribution of the generated droplets is measured with IPI (Interferometric Particle Imaging). 3D-PTV measurements have been performed to investigate the influence of turbulence on the droplet motions. The spatial distribution of the droplets in turbulence using the so-called Radial Distribution Function (RDF) is carried out, which quantifies the clustering of the droplets under turbulence conditions. Indeed, we observe different levels of clustering depending on the turbulence intensity and the mean droplet size. Additionally, 3D-PTV allows us to measure velocity statistics of the droplets and thereby the influence of the turbulence on droplet trajectories, both individually and collectively.

DISSERTATIONS

-

SCIENTIFIC PUBLICATIONS

-

PROJECT LEADERS

HJH Clercx, GJF van Heijst

RESEARCH THEME

Complex dynamics of fluids

PARTICIPANTS

AM Yavuz, RPJ Kunnen, HJH Clercx, F Toschi, GJF van Heijst

COOPERATIONS

BJ Geurts (UT)

FUNDED

FOM	
University	-
FOM	100 %
STW	-
NWO Other	-
Industry	-
TNO	-
GTI	-
EU	-
Scholarships	-

START OF THE PROJECT

2011

INFORMATION

HJH Clercx
040 247 2680
h.j.h.clercx@tue.nl

RPJ Kunnen
040 247 3194
r.p.j.kunnen@tue.nl
www.phys.tue.nl/wdy/

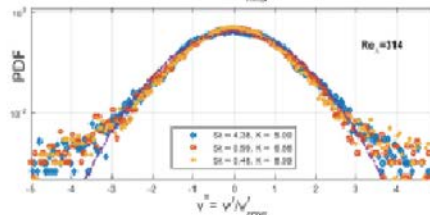
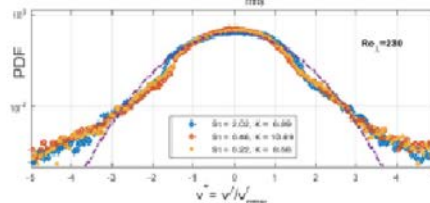
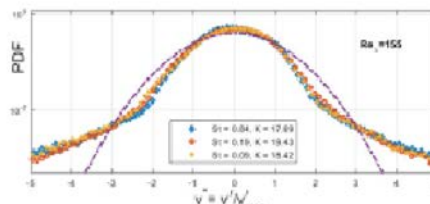
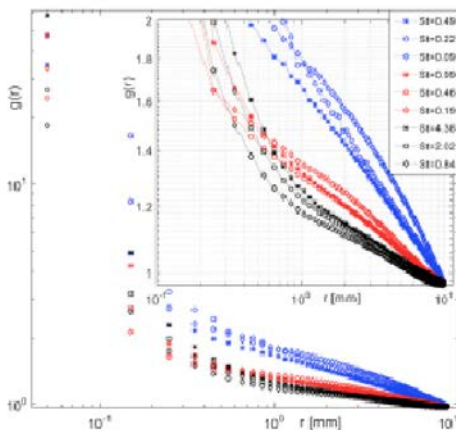

POPULATION DYNAMICS UNDER FLOW

PROJECT LEADERS

F Toschi, HJH Clercx

RESEARCH THEME

Complex dynamics of fluids

PARTICIPANTS

F Tesser, P Perlekar, HJH Clercx,
F Toschi, JCH Zeegers, KMJ Alards

COOPERATIONS

R Benzi (Univ. Tor Vergata, Italy),
L Brunsveld (BMT, TU/e),
MH Jensen (Niels Bohr Institute,
Denmark), DR Nelson (Harvard
University, USA), S Pigolotti
(Universidad politécnica de
Cataluña, Spain)

FUNDED

FOM
University -
FOM 100 %
STW -
NWO Other -
Industry -
TNO -
GTI -
EU -
Scholarships -

START OF THE PROJECT

2012

INFORMATION

F Toschi
040 247 3911
f.toschi@tue.nl
www.phys.tue.nl/wdy

PROJECT AIM

Population dynamics deals with the study of birth, death and growth processes of biological species. These processes are severely affected by the local ecosystems, by the presence of nutrients, and by the local population density, moreover all these factors can be strongly influenced in a liquid environment by the presence of a flow. Effects can be visible at macroscales in terms of strong non homogeneities. The aim of the present project is to validate the continuum model for the growth of populations extending it to flow conditions, using a combination of dedicated experiments of growth of bacteria in microfluidic devices and numerical discrete particle simulations.

PROGRESS

From the experimental side the propagation speed of populations of *E. coli* bacteria has been measured in microfluidic channels under different flow conditions, both upstream and downstream. The results concerning the front speed as a function of the flow intensity is summarized in the Figure below. Particular attention has been given to the convergence of data at high counter-flow case: the fact that the front of bacteria keeps propagating at a constant speed irrespectively to the velocity of the fluid makes us distinguish the mechanisms of growth at the wall from the fisher growth of the population suspended in the channel. From the numerical side, a simplified algorithm, inspired by optics, has been implemented for front propagation in random quenched media composed of high diffusion areas. It has also been extended to work for a random distribution of impenetrable squared obstacles.

DISSERTATIONS

-

SCIENTIFIC PUBLICATIONS

-

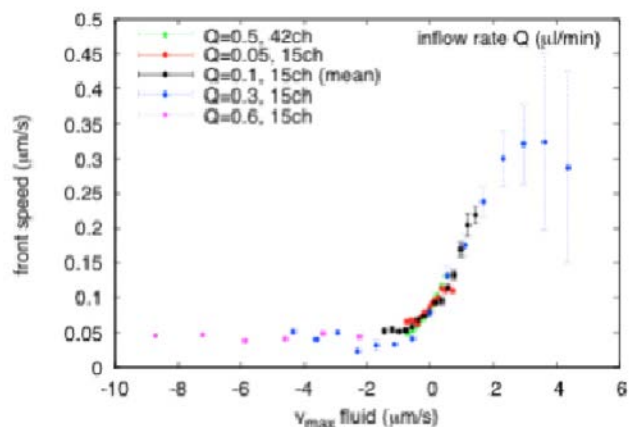

Experimental measurements of bacteria front speed propagating in microfluidic rectangular channels as a function of the centerline velocity. At high counter-flow values the data converge to a finite positive value.

OPTIMALISATIE VAN VOORTSTUWING DOOR EN OVER WATER

PROJECT AIM

Develop a system to visualize and analyze the flow around a human swimmer and extract information from resolved flow field of interest for trainers, coaches and sports scientists. Visualization will be done by means of a bubble system and PIV routine. Furthermore the influence of different and new kinds of feedback to swimmers will be tested on a group of swimmers. In the end the goal is to contribute to improved performance of Dutch elite swimmers.

PROGRESS

The bubble- and camera system to visualize the flow around a human swimmer are developed and being implemented in the swimming pool. It is planned to do PIV (inspired) measurements using a synthetic refocusing method to focus at planes of interest. This method is tested on artificial images. Also artificial images of simplified bubble swarms rising through a well-known vortex are created. It is studied how to distill the velocity field of the flow from the bubble velocities. A review article about the hydrodynamics of the hand of a swimmer is submitted. Lastly, the flow around a swimmer's hand with varying finger spread is studied in a graduation project by numerical simulations and wind tunnel experiments. Higher resolution are required to properly resolve the details of the flow in between the fingers.

DISSERTATIONS

-

SCIENTIFIC PUBLICATIONS

-

PROJECTLEADERS

HJH Clercx

RESEARCHTHEME

Complex dynamics of fluids

PARTICIPANTS

J van Houwelingen, PJ Beek,
HJH Clercx, GJF van Heijst,
RPJ Kunnen, W van de Water

COOPERATIONS

R Verzicco (UT), PJ Beek (VU),
J Westerweel (TUD),
InnoSport

FUNDED

STW	
University	-
FOM	-
STW	100 %
NWO Other	-
Industry	-
TNO	-
GTI	-
EU	-
Scholarships	-

START OF THE PROJECT

2013

INFORMATION

HJH Clercx
040 247 2680
h.j.h.clercx@tue.nl
www.phys.tue.nl/wdy/

THE SUDDEN DEATH OF ATMOSPHERIC TURBULENCE

PROJECT LEADERS

BJH van de Wiel, HJH Clercx

RESEARCH THEME

Complex dynamics of fluids

PARTICIPANTS

IGS van Hooijdonk, HJH Clercx,
BJH van de Wiel

COOPERATIONS

-

FUNDED

NWO-ALW	
University	-
FOM	-
STW	-
NWO Other	100 %
Industry	-
TNO	-
GTI	-
EU	-
Scholarships	-

START OF THE PROJECT

2013

INFORMATION

HJH Clercx
040 247 2680
h.j.h.clercx@tue.nl
www.phys.tue.nl/wdy/

PROJECT AIM

A well-known phenomenon in the atmospheric boundary layer is the sudden decrease in turbulence intensity. This generally occurs in the case of weak winds (shear production) strong cooling at the surface (buoyant destruction). Data analysis of atmospheric data (Cabauw weather tower), theoretical analysis and direct numerical simulation are used to investigate this phenomenon. Though originally the research is motivated by meteorological application, we also aim to obtain fundamental insight in the laminarisation of turbulence near a cooled surface.

PROGRESS

Numerical simulations were performed of an idealized model for the nocturnal boundary layer. Previously predicted results (van de Wiel 2007) were confirmed: Monin-Obukhov similarity predicts a collapse of turbulence occurs if the surface heat flux is greater than can be sustained by a turbulent flow. Indeed, the same occurred in closure-independent direct numerical simulations. Additionally, alternative indicators of an imminent regime shift were investigated. It appears that for our idealised set-up the transition from turbulent to laminar can be predicted, without relying on parameterizations for turbulence. These results were submitted to boundary layer meteorology.

DISSERTATIONS

-

SCIENTIFIC PUBLICATIONS

1. van Hooijdonk I, Donda J, Clercx H, Bosveld F, van de Wiel B (2015) Shear Capacity as Prognostic for Nocturnal Boundary Layer Regimes. *J Atmos Sci* 72(4):1518-1532, DOI 10.1175/JAS-D-14-0140.1

ROTATING RAYLEIGH-BÉNARD TURBULENCE: NUMERIC SIMULATIONS

PROJECT AIM

In this project the dynamics of inertial and buoyant particles in Rayleigh-Bénard convection is investigated numerically. Inertial particles will be implemented in the Rayleigh-Bénard system and the effect of these particle properties on the thermal convection and on the transition between turbulent states explored. In particular, the interest is on the preferential accumulation of particles in plumes and/or vortices, feedback on the flow and the possible modification of the interaction between bulk and boundary layer. Two numerical codes are used, a finite-difference code for exploring a cylindrical setup and a Lattice Boltzmann code for modeling a horizontally unbounded system.

PROGRESS

To investigate rotating RB convection in a Lagrangian framework tracer particles are implemented in the cylindrical finite-difference RB code. In figure 1 examples trajectories of tracer particles are shown both for non-rotating ($Ro = \infty$) and rotating ($Ro = 0.1$) RB convection. Rotation clearly changes the structures of these trajectories and by collecting velocity, acceleration and temperature statistics of the particles the influence of rotation on flow structure and heat flux is investigated. Statistics measured near the center is compared to statistics measured near the horizontal plates in order to see the role of boundary layers. Moreover the statistics are compared to experimental results and a very good agreement is found. As a next step (thermal) inertial particles with mechanical and thermal feedback on the flow are included in order to investigate whether the flow and heat flux can be influenced using these 'active' particles.

DISSERTATIONS

-

SCIENTIFIC PUBLICATIONS

-

Trajectories of tracer particles in cylindrical Rayleigh-Bénard convection. In the left figure the non-rotating case ($Ro = \infty$) is shown and in the right figure the rotating case ($Ro = 0.1$) is shown.

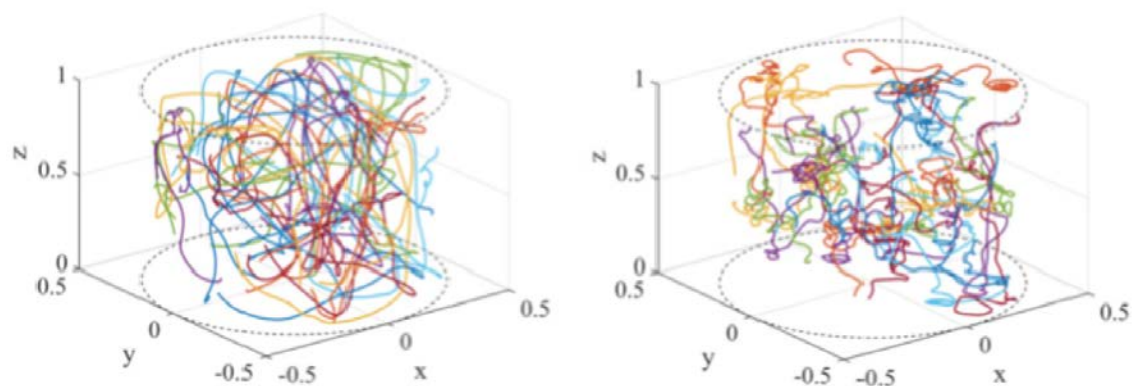

PROJECT LEADERS

F Toschi, HJH Clercx

RESEARCH THEME

Complex dynamics of fluids

PARTICIPANTS

KMJ Alards, HJH Clercx, F Toschi, RPJ Kunnen, PR Joshi, H Rajaei

COOPERATIONS

R Verzicco (UT), D Lohse (UT)

FUNDED

FOM	
University	-
FOM	100 %
STW	-
NWO Other	-
Industry	-
TNO	-
GTI	-
EU	-
Scholarships	-

START OF THE PROJECT

2014

INFORMATION

F Toschi
040 247 3911
f.toschi@tue.nl
www.phys.tue.nl/wdy/

SEDIMENT TRANSPORT BY VORTICES: A FUNDAMENTAL STUDY FROM THE LAB TO THE OCEAN

PROJECT LEADERS

M Duran Matute

RESEARCH THEME

Complex dynamics of fluids

PARTICIPANTS

M Duran Matute, AS Gonzalez Vera,
GJF van Heijst

COOPERATIONS

R Verzicco (UT), WP Breugem
(TUD)

FUNDED

NWO-VENI	
University	-
FOM	-
STW	-
NWO Other	100 %
Industry	-
TNO	-
GTI	-
EU	-
Scholarships	-

START OF THE PROJECT

2014

INFORMATION

M Duran Matute
040 247 2160
m.duran.matute@tue.nl
www.phys.tue.nl/wdy/

PROJECT AIM

In environmental flows (e.g. in rivers or at the coast), vortices can play an important role in shaping the sediment bed underneath. The main aim of the project is to provide a complete and coherent theory behind sediment transport by barotropic vortices in such environmental water systems. Through a combination of laboratory experiments and numerical simulations, the full cycle of erosion, transport, and deposition of sediment by the vortices will be systematically studied.

PROGRESS

In the first stage of this project, two main experimental research lines have been undertaken: 1) the study of particle trajectories in the boundary layers below a swirl flow, and 2) the morphodynamics under an oscillating swirl flow. The first study revealed that the trajectories of the particles inside the boundary layers are consistently well-defined logarithmic spirals. In the second line of research, the formation and evolution of ripples has been studied. It was observed that their wavelength depends on both the amplitude and frequency of the oscillating flow. This contrasts with the results in oscillating channel flows where the wavelength depends only on the excursion length of the flow. Our results can be explained by the changes on the flow itself as the parameters of the problem are varied.

DISSERTATIONS

-

SCIENTIFIC PUBLICATIONS

1. Sassi, M.G., Duran Matute, M., Kessel, T. van, Gerkema, T. (2015). Variability of residual fluxes of suspended sediment in a multiple-inlet system. The Dutch Wadden Sea, Ocean Dyn., doi:10.1007/s10236-015-0866-2.
2. Duran Matute, M. & Gerkema, T. (2015). Calculating residual flows through a multiple-inlet system : the conundrum of the tidal period. Ocean Dynamics.





Prof.dr.ir. OCG Adan

In the group Transport in Permeable Media, TPM, of the department of Applied Physics at the Eindhoven University of Technology research is performed on transport and phase changes in permeable media. Our mission is to advance materials technology through an in-depth understanding of transport physics in permeable media, in support of various technology domains, such as high tech materials, petro physics and thermal energy storage. The interaction between transport of fluids and solutes, phase changes and material response on different scale levels -typically in the micrometer to millimetre range- forms the core of our research activities. Inherently, interdisciplinarity is in TPMs genes, encompassing transport physics, materials science, chemistry and biology. The experiment is at the heart of the group, which is due to the unique opportunities of our MRI Infrastructure, consisting of nine home-built or -modified scanners operating at fields ranging from 0.7-4.7 T. TPMs research profile is based on use-inspired basic research. Consequently, interaction with industrial players forms a cornerstone in our approach. For this reason, fruitful partnerships exist with TNO, AkzoNobel and Oce. The work is mainly funded by the Dutch Technology Foundation (STW), Materials Innovation Institute (M2I).

PREDICTIVE MODEL FOR THE HYGRO-MECHANICAL BEHAVIOUR DURING FIRST HEAT UP OF REFRACTORY CONSTRUCTION IN STEELMAKING INSTALLATIONS

PROJECT AIM

To understand the transport mechanism of liquid moisture/vapor in monolithic refractories during first heat up (up to 400 °C). It is in this range of temperatures that steam pressure can build up and cause the material to spall (i.e. explode). The target materials of interest are: conventional castables (CC), low-cement castables (LCC) and other materials with a low (or zero) cement content. Experiments that simultaneously measure the temperature and moisture content are carried out and used to validate the conceptual model.

PROGRESS

The high-temperature Nuclear Magnetic Resonance (NMR) experimental setup is functioning and results have been generated (and in continuation) for the first-heating up of conventional castable materials. These results have been achieved for heating rates around 3 °C/min., with a sample surface temperature of 350 °C and thermal gradient in the range of 100+ °C across the whole sample. The experiments have been carried out for samples with different curing times: (1) 24 hours and (2) 48-72 hours. What can be concluded so far is that the drying behavior is very sensitive to the curing time, where in case (1) there is more residual free water being removed from the pores of the material, whereas in case (2) dehydration and water in the smaller pores (e.g. gel/capillary pores) starts to play a greater role.

DISSERTATIONS

-

SCIENTIFIC PUBLICATIONS

-

PROJECTLEADERS

L Pel

RESEARCHTHEME

Complex dynamics of fluids

PARTICIPANTS

A Barakat

COOPERATIONS

TATA Steel, Kerneos, Almatris

FUNDED

Materials Innovation Institute (m2i)

University -

FOM -

STW -

NWO Other -

Industry 100 %

TNO -

GTI -

EU -

Scholarships -

START OF THE PROJECT

2013

INFORMATION

A Barakat

a.barakat@tue.nl

TRUE SOLVENT FREE (TSoF): TOWARDS THE NEXT GENERATION OF WATERBORNE COATINGS

PROJECT LEADERS

HP Huinink

RESEARCH THEME

Complex dynamics of fluids

PARTICIPANTS

HP Huinink, SJF Erich, OCG Adan, P Venema (Wageningen University), JDR Harting, J Keddie (University of Surrey), B Voogt, MPJ Wouters

COOPERATIONS

DSM Coating Resins, Drywood, AkzoNobel, TNO, NVVT, SHR, Océ

FUNDED

STW	
University	-
FOM	-
STW	100 %
NWO Other	-
Industry	-
TNO	-
GTI	-
EU	-
Scholarships	-

START OF THE PROJECT

2014

INFORMATION

B Voogt
b.voogt@tue.nl

PROJECT AIM

The scientific aim is to understand film formation of new coatings consisting of polymer particles (acrylate based) that can be plasticized by water.

PROGRESS

Extensive studies have been done on the drying behavior of polymer dispersions in water ("latex") containing hard ("glassy") and soft ("rubber-like") particles and blends (mixtures) thereof. It was found that soft particles seem to hinder the evaporation of water due to possible skin formation on the latex-air interface. This is independent of the concentration of soft particles, even in blends, suggesting preferential accumulation of the soft particles on the interface.

DISSERTATIONS

-

SCIENTIFIC PUBLICATIONS

-

TOWARDS GREEN INK

PROJECT AIM

With current health and safety regulations, the reduction of the volatile components in printer ink is an ongoing challenge. Water based inks are therefore increasingly used. These inks contain, amongst other things, water, co-solvent and pigment. The pigment, which results in the visual image, is minimized to reduce costs and obtain a more eco-friendly ink. The project aim is to develop a mathematical model that quantitatively describes particle penetration into paper. We aim to predict the penetration depth of the pigment, and find the determining parameters. Ink can then be optimized in order to contain a lower pigment concentration. To describe ink penetration in paper we need to describe four processes: evaporation, sorption into the fibres, capillary suction in the pores and agglomeration of the particles. The experiments are conducted using Nuclear Magnetic Resonance (NMR), a non-destructive technique that visualizes the liquid components inside a porous sample in a space and time resolved manner. Due to the challenges with studying paper (i.e. swelling, big pore size distribution, fibres), Al_2O_3 is used as a model porous medium. Furthermore we use Fe_2O_3 nanoparticles ($D_{\text{avg}} = 30 \text{ nm}$) as a model for the pigment particles.

PROGRESS

In the past year we have been working towards a closer comparison between our model system (model ink and model paper) and the application, therefore we have added particles to our model ink and have started quantitative experiments of particle penetration in porous media. We have found a strong dependency on pore size as we would expect. Secondly we investigated the front speed of the liquid front with and without particles and have found a decrease in front speed probably due to the higher viscosity of the impeding liquid. On the other hand we have done preliminary tests on CaCO_3 which is used as a paper coating in the offset printing industry and have found a good comparison with the results we have found using Al_2O_3 . This indicates that the results we find using Al_2O_3 samples can be used to predict the liquid penetration behaviour in the coating layer for coatings of only CaCO_3 (no latex). The effect of added latex in paper coatings seems to follow similar behaviour but the scaling is different which implies a difference of contact angle or tortuosity. Further research would however be necessary to validate these initial observations and theories.

DISSERTATIONS

-

SCIENTIFIC PUBLICATIONS

-

PROJECT LEADERS

HP Huinink, OCG Adan

RESEARCH THEME

Complex dynamics of fluids

PARTICIPANTS

CJ Kuijpers

COOPERATIONS

M2i, Oce

FUNDED

M2i, Oce

University -

FOM -

STW -

NWO Other -

Industry 100 %

TNO -

GTI -

EU -

Scholarships -

START OF THE PROJECT

2013

INFORMATION

CJ Kuijpers

040 247 4063

c.j.kuijpers@tue.nl

Movement of Fe_2O_3 nanoparticles visualized using moisture profiles of water-glycerol mixtures during capillary suction in porous Al_2O_3 with an average pore size of $0.2 \mu\text{m}$ (a), $1.2 \mu\text{m}$ (b) and $16 \mu\text{m}$ (c).

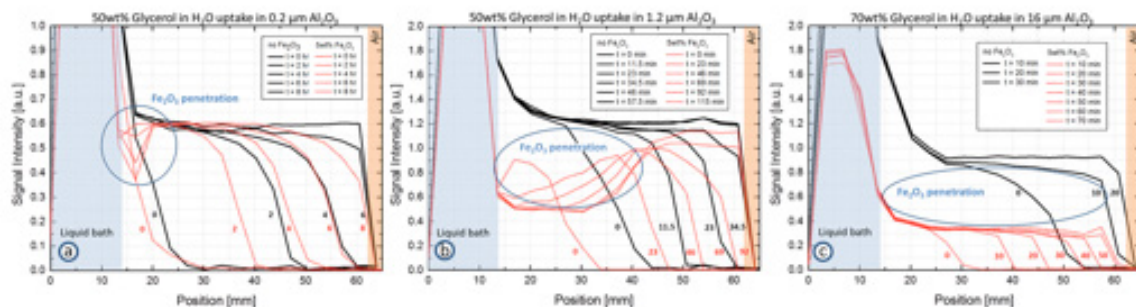

SALT WICK ACTION IN BUILDING MATERIALS, AN NMR STUDY

PROJECT LEADERS

L. Pel, OCG Adan

RESEARCH THEME

Complex dynamics of fluids

PARTICIPANTS

R Pishkari

COOPERATIONS

-

FUNDED

STW

University -

FOM -

STW 100 %

NWO Other -

Industry -

TNO -

GTI -

EU -

Scholarships -

START OF THE PROJECT

2012

INFORMATION

R Pishkari

r.pishkari@tue.nl

PROJECT AIM

Infrastructure rehabilitation and replacement costs thousands billion dollars per year. The biggest issue in structural deterioration is related to the corrosion of the concrete reinforcing steel. One of the main causes of corrosion of steel bars in concrete is present of chloride in the concrete which can be result of deicing salt or exposure to sea water. Water drags chloride in to the material. In cementitious materials part of the chloride ions bound (physically or chemically) to the structure, the bound chlorides do not initiate or propagate corrosion. Many studies has been done to estimate the chloride binding rate, chloride penetration depth, and threshold. The main aim of this project is to study chloride ingress into concrete by Nuclear Magnetic Resonance (NMR). NMR has been used to measure sodium, chloride and water quasi-simultaneously and nondestructively in the porous structure of materials. In order to study the transport of chloride we have focused on Wick action. This is the situation where there is a permanent supply of moisture and ions on one side of materials, where as the other side is exposed to continuous drying in the open air. The continues flow of solution in to the material caused by capillary deposits salt to the evaporation surface or inside of the material (where the steady state liquid-evaporation interface is located). The salt concentration increases at the evaporation surface (or at the front) and when it reaches to saturation limit starts to crystalize there.

PROGRESS

- Diffusion of sodium chloride in concrete. The ion concentration profile when water saturated specimens were exposed to brine water in one side was measured and the effective diffusion coefficient was calculated for each material (using the Fick's First Law of diffusion). Obviously the diffusion process for concrete is too slow, to speed up the chloride transport the migration test has been also utilized.

- Rapid Chloride Migration (RCM) test for concrete. ASTM (American Society of Testing and Materials) is an standard migration cell test in which an electric field is applied to a concrete specimen. The ion distribution in certain time steps has been monitored by NMR to determine the non-steady-state chloride migration coefficient.

- The wick action experiment has been also done for brick, lime stone and concrete.

DISSERTATIONS

-

SCIENTIFIC PUBLICATIONS

1. Wick action in porous building materials as studied by NMR; Materials, Systems and Structures in Civil Engineering - August 2016. (conference proceeding).
2. NMR study of chloride transport in concrete during Wick action; The Fifth International Symposium on Life -Cycle Civil Engineering, IALCCE2016 (conference proceeding).

WATER TRANSPORT THROUGH COATINGS ON WOOD

PROJECT AIM

An important reason to apply coatings on wood is to protect wood against water. In order to use waterborne coatings for woodcare the main factors determining transport through these coatings have to be understood. Waterborne coatings are intrinsically more sensitive to water. Further, the influences of wood on the coating structure and permeability have to be understood. In this project the migration of water through waterborne coatings on wood will be studied with NMR imaging tools. NMR imaging is very suitable tool for visualizing water distributions in the wood and the coating. Further, NMR also gives information about the state of water (bound or free) and plasticization effects (polymer-water interactions).

PROGRESS

To investigate water transport through coatings on wood, we started to analyse transport through the wood itself. Oak, teak and pine sapwood were selected as the wood types covering a whole range of low to high density wood. The first experimental part on uncoated wood was to do the calibration of moisture content for each type with the low resolution NMR. The calibration results allow us to directly quantify the amount of water from the NMR signal during wetting and drying of wood samples. Relaxation analyses were performed to understand the state of water within the wood, e.g. bound or free water in lumen or voids. Coating were formulated, using well known composition; 3 type of coatings, WB alkyd, SB alkyd and WB acrylic, specifically for this project. Next to separate investigation on coatings, e.g. by dynamic vapour sorption, wet cup and high resolution MRI, we have investigated the wetting and drying of coated wood.

DISSERTATIONS

-

SCIENTIFIC PUBLICATIONS

1. Ö. Gezici-Koç, C.A.A.M. Thomas, M.B. Michel, S.J.F. Erich, H.P. Huinink, J. Flapper, F.L. Duivenvoorde, L.G.J. van der Ven, O.C.G. Adan. 'In-depth study of drying solvent-borne alkyd coatings in presence of Mn and Fe based catalysts as cobalt alternatives'. *Materials Today Communications* 7 (2016), 22-31.
2. Ö. Gezici-Koç, S.J.F. Erich, H.P. Huinink, L.G.J. van der Ven, O.C.G. Adan. 'Bound and free water distribution in wood during water uptake and drying as measured by magnetic resonance imaging'. Submitted to *Cellulose*.

PROJECTLEADERS

SJF Erich, HP Huinink, OCG Adan

RESEARCHTHEME

Complex structures of fluids

PARTICIPANTS

O Gezici-Koç

COOPERATIONS

TNO

FUNDED

AkzoNobel Decorative Paints,
Sassenheim, the Netherlands

University -

FOM -

STW -

NWO Other -

Industry 100 %

TNO -

GTI -

EU -

Scholarships -

START OF THE PROJECT

2012

INFORMATION

SJF Erich

040 247 3830

s.j.f.erich@tue.nl

ELEMENTARY PROCESSES IN GAS DISCHARGES



Prof.dr.ir. GWM Kroesen



Prof.dr.ir. V Banine



Prof.dr.ir. U Ebert

Our mission is to study the elementary processes in gas discharges by a mix of theory, modelling, and diagnostics.

A thorough understanding of the intensity and effectivity of elementary processes like ionization, recombination, transport, radiation, excitation, de-excitation, chemical reactions and surface processes enables the group to develop predictive models of a large range of plasmas. The understanding is obtained by a strong interleaved integration of state-of-the-art plasma diagnostics with advanced plasma models. Those models then in turn enable users of the plasmas to optimize the plasma source for their specific application. Over the years, the range of applications the group has worked on has shifted continuously: from plasma etching via lighting to medical applications and many other areas. However, the scientific scope of the group has not shifted: continuously the focus has been with the elementary processes in and the physics of plasmas.

Some applications fade and other applications lure, but plasma physics remains our core.

If you are not familiar with plasma and gas discharge physics, you may wish to consult the Wikipedia page about plasma physics. Alternatively, the applications and techniques sections of this site provide an explanation of the plasma sources and measurement and modelling techniques that are used in our group. If nothing else, the pictures shown there may convince you of the visual beauty of the topic of our research!

PULSED MICROWAVE PLASMAS FOR BETTER CONTROL OF DEPOSITION PROCESSES

PROJECT AIM

In pulsed operation, the microwave plasma will behave completely different from the steady state case. In order to be able to tailor these plasmas to the needs of experimenters and end users, a thorough study will be performed on the behaviour of the plasma both in the on-period and in the off-period of the pulse. Experimental methods include Thomson scattering, Laser induced fluorescence and Optical Emission Spectroscopy. The plasma will also be modelled. We choose to begin with volume averaged models of the discharge chemistry. Later on, these models can be integrated in full 2D models.

PROGRESS

A solid state microwave power supply has been installed to create and study molecular gas plasmas (O_2). Diagnostics on $Ar/O_2/SiCl_4$ plasmas have been performed by broadband emission spectroscopy. Measurements of the electron and negative ion densities have been performed on the argon and argon-oxygen plasmas by Thomson scattering. The modelling platform PLASIMO now contains a module that is capable of calculating transport coefficients more accurately. Additionally ab initio calculations have been performed on $SiCl/SiO/SiO^+$ in order to predict the spectral emission. The construction of a stable 2D model using an $O_2-SiCl_4//Ar-SiCl_4$ chemistry is still ongoing work. It is expected that a self-consistent diffusion algorithm will improve the stability and the convergence rate of the 2D model.

DISSERTATIONS

-

SCIENTIFIC PUBLICATIONS

1. Carbone, E.A.D., Sadeghi, N., Vos, E.G.P., Hübner, S., Veldhuizen, E.M. van, Dijk, J. van, Nijdam, S. & Kroesen, G.M.W. (2015). Spatio-temporal dynamics of a pulsed microwave argon plasma : ignition and afterglow. *Plasma Sources Science and Technology*, 24(1):015015.
2. Carbone, E.A.D., Dijk, J. van & Kroesen, G.M.W. (2015). Experimental evidence of resonant energy collisional transfers between argon 1s and 2p states and ground state H atoms by laser collisional induced fluorescence. *Plasma Sources Science and Technology*, 24, 025036-1/10.
3. Kemaneci, E.H., Carbone, E.A.D., Jimenez-Diaz, M., Graef, W.A.A.D., Rahimi, S., Dijk, J. van & Kroesen, G.M.W. (2015). Modelling of an intermediate pressure microwave oxygen discharge reactor : from stationary two-dimensional to time-dependent global (volume-averaged) plasma models. *Journal of Physics D: Applied Physics*, 48(43):435203.

PROJECTLEADERS

J van Dijk, S Nijdam, GMW Kroesen

RESEARCHTHEME

Complex dynamics of fluids

PARTICIPANTS

J van Dijk, S Nijdam, GMW Kroesen, EAD Carbone, EH Kemaneci, S Hofmann, JFJ Janssen

COOPERATIONS

DRAKA

FUNDED

STW, DRAKA	
University	-
FOM	-
STW	69 %
NWO Other	-
Industry	31 %
TNO	-
GTI	-
EU	-
Scholarships	-

START OF THE PROJECT

2010

INFORMATION

S Nijdam
040 247 4342
s.nijdam@tue.nl
<http://www.tue.nl/staff/s.nijdam>

FUEL FEEDSTOCK PRODUCTION BY A COMBINED APPROACH OF CONTROLLED PLASMA CONVERSION AND MEMBRANE SEPARATION

PROJECT LEADERS

GWM Kroesen, J van Dijk

RESEARCH THEME

Mathematical and computational methods for fluid flow analysis

PARTICIPANTS

S Tadayon, WAAD Graef

COOPERATIONS

This project is part of STW project 13584. The other participants are: dr. W.A. Bongers of the Dutch Institute for Fundamental Energy Research, prof. dr. D.C. Nijmeijer from the University of Twente.

FUNDED

STW/Alliander	
University	-
FOM	-
STW	100 %
NWO Other	-
Industry	-
TNO	-
GTI	-
EU	-
Scholarships	-

START OF THE PROJECT

2015

INFORMATION

P Koelman
040 247 5765
p.m.j.koelman@tue.nl
<http://plasimo.phys.tue.nl>

PROJECT AIM

The nature of renewable energy sources is typically intermittent and does not match with our energy demand. When the energy production does exceed the demand of energy, the surplus is stored in batteries, which is an inefficient and expensive process. One idea is to store this energy by reversing the process of burning fossil fuel. By plasma assisted CO₂ dissociation CO is produced, where after fuels are produced. The goal of our project is to improve the efficiency of the plasma assisted CO₂ dissociation. This will be done by numerical simulations of CO₂ microwave plasmas.

PROGRESS

We have developed a global model of CO₂ with 72 species and exceeding 3500 reactions. This model gives insight in the chemical processes in the plasma and will enable us to determine the important processes. This is an important milestone in the development of a spatially resolved model. Later in the project, results of the model will be validated using experimental results of the groups of dr. Bongers and prof. dr. Nijmeijer.

DISSERTATIONS

-

SCIENTIFIC PUBLICATIONS

1. De Bie, C., Dijk, J. van & Bogaerts, A. (2015). The dominant pathways for the conversion of methane into oxygenates and syngas in an atmospheric pressure dielectric barrier discharge. *Journal of Physical Chemistry C*, 119(39), 22331-22350.

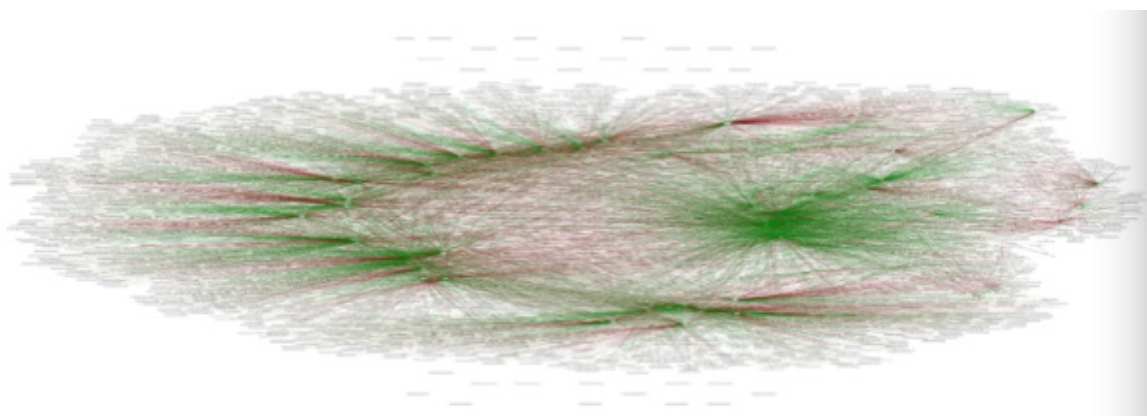

An illustrative figure indicating the complexity of the model of 72 species and more than 3500 reactions. The species are connected by red and green lines indicating the presence of a reaction.

PHYSICS AND CHEMISTRY OF PLASMAS FOR WOUND HEALING

PROJECT AIM

This project concerns the characterization of cold atmospheric pressure plasmas developed for use in medicine. Its aim is the determination of radical densities and fluxes in the effluent of an RF plasma jet, time and space resolved, and the characterization of oxygen chemistry that takes place in the effluent. The characterization of flow dynamics is essential for understanding the admixing of atmospheric air into the plasma effluent and therefore the chemistry.

PROGRESS

This project has ended in 2015. During 2015 the PhD candidate defended his thesis and obtained his degree and two articles were published in peer-reviewed international journals.

DISSERTATIONS

1. Atmospheric pressure RF plasma jet : characterization of flow and O₂ chemistry. Eindhoven: Technische Universiteit Eindhoven. ((Co-)promot.: prof.dr.ir. G.M.W. Kroesen, dr.ir. P.J. Bruggeman & dr.dipl.-ing. A. Sobota).

SCIENTIFIC PUBLICATIONS

1. Zhang, S., Sobota, A., Veldhuizen, E.M. van & Bruggeman, P.J. (2015). Gas flow characteristics of a time modulated APPJ : the effect of gas heating on flow dynamics. *Journal of Physics D: Applied Physics*, 48, 015203-1/14.
2. Zhang, S., Sobota, A., Veldhuizen, E.M. van & Bruggeman, P.J. (2015). Temporally resolved ozone distribution of a time modulated RF atmospheric pressure argon plasma jet : flow, chemical reaction, and transient vortex. *Plasma Sources Science and Technology*, 24(4), 045015-1/9.

PROJECTLEADERS

GWM Kroesen

RESEARCHTHEME

Complex dynamics of fluids

PARTICIPANTS

S Zhang, EM van Veldhuizen,
A Sobota

COOPERATIONS

-

FUNDED

Chinese Scholarship Council
Dutch Technology Foundation (STW)
University -
FOM -
STW 10 %
NWO Other -
Industry -
TNO -
GTI -
EU -
Scholarships 90 %

START OF THE PROJECT

2011

INFORMATION

A Sobota
040 247 4340
a.sobota@tue.nl

PROFILING OF OPTICAL SURFACES USING A PLASMA JET

PROJECT LEADERS

S Nijdam, WL IJzerman

RESEARCH THEME

Complex dynamics of fluids

PARTICIPANTS

M van der Schans

COOPERATIONS

-

FUNDED

Philips

University -

FOM -

STW -

NWO Other -

Industry 100 %

TNO -

GTI -

EU -

Scholarships -

START OF THE PROJECT

2014

INFORMATION

S Nijdam

040 247 4342

s.nijdam@tue.nl

<http://www.tue.nl/staff/s.nijdam>

PROJECT AIM

As the shapes of the illumination optics become increasingly more complex, with typical feature sizes ranging from several tens of microns to a millimeter, new measurement techniques to profile these surfaces have to be developed. The proposed method is based on so-called plasma bullets, which are fast moving ionization fronts generated in a gas flow. Furthermore, the physics of plasma bullets, of which more detailed understanding is important in the development of novel applications, are experimentally investigated by (nonlinear) laser spectroscopic diagnostics.

PROGRESS

New insights in the spatial and temporal development of plasma bullets have been obtained by imaging the plasma bullets when the setup is first turned on using sub-nanosecond exposure times. Another experimental setup for electric field measurements by means of four-wave mixing has been built and preliminary results have recently been obtained.

DISSERTATIONS

-

SCIENTIFIC PUBLICATIONS

-

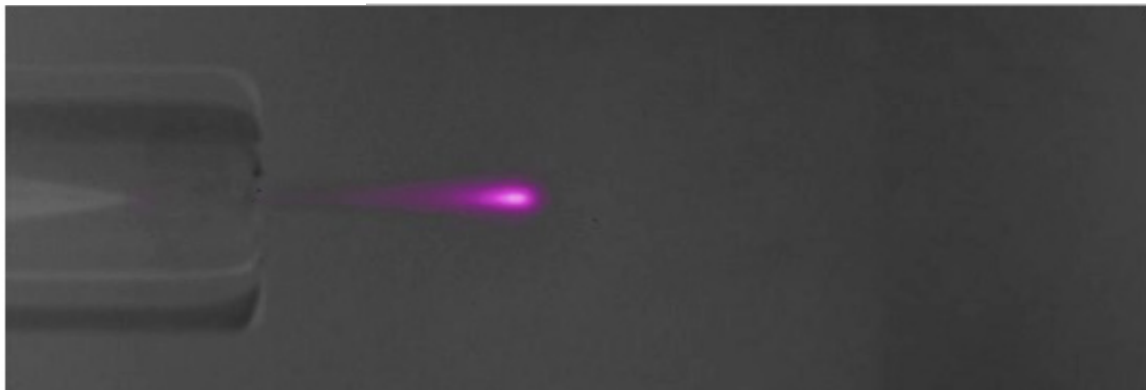

Plasma bullet

EFFICIENT ELECTRICAL TO CHEMICAL ENERGY CONVERSION VIA SYNERGY EFFECTS IN PLASMA- AND CATALYTIC TECHNOLOGY

PROJECT AIM

Transformation of CO₂ into fuels that are transportable with current infrastructure seems a promising idea to solve one part of global warming. In this project, a multi-disciplinary approach is pursued to cover the entire process chain from CO₂ and H₂O to CH₄ by advanced microwave plasma source design, diagnostics, modeling, and catalytic follow up chemistry. Dissociation of CO₂ in a non-equilibrium electrical gas discharge is the first section of this triple part project, and maximization of the whole process efficiently through admixture of water in the first part is the final aim of the project. Our project is to investigate numerically the effect of adding H₂O to CO₂ dissociation in microwave plasma.

PROGRESS

We have developed a global model of water with 19 species and 44 reactions. This model is a basic model for more complex chemistry and gives insight in the importance of the various chemical processes that occur in the plasma. With the help of this model and the extended version we are able to develop a spatially resolved model. In later steps, we can validate our model with experimental results of the groups of dr. Bongers and prof.ir. Lefferts.

DISSERTATIONS

-

SCIENTIFIC PUBLICATIONS

1. De Bie, C., Dijk, J. Van & Bogaerts, A. (2015). The dominant pathways for the conversion of methane into oxygenates and syngas in an atmospheric pressure dielectric barrier discharge. *Journal of Physical Chemistry C*, 119(39), 22331-22350.

PROJECTLEADERS

GWM Kroesen, J van Dijk

RESEARCHTHEME

Mathematical and computational methods for fluid flow analysis

PARTICIPANTS

PMJ Koelman, WAAD Graef

COOPERATIONS

This project is part of STW project 13581.

The other participants are:
dr. W.A.Bongers of the Dutch Institute for Fundamental Energy Research. Prof.dr.L.Lefferts from University of Twente.

FUNDED

STW/Alliander	
University	-
FOM	-
STW	100 %
NWO Other	-
Industry	-
TNO	-
GTI	-
EU	-
Scholarships	-

START OF THE PROJECT

2015

INFORMATION

S Tadayon Mousavi
040 247 5765
s.tadayon.mousavi@tue.nl
<http://plasimo.phys.tue.nl>

PLASMA SOURCE TECHNOLOGIES FOR PLASMA-BASED EUVL OPTICS CLEANING

PROJECT LEADERS

GMW Kroesen, S Nijdam, J Beckers

RESEARCH THEME

Complex dynamics of fluids

PARTICIPANTS

FMJH van de Wetering

COOPERATIONS

ASML

FUNDED

STW (NanoNext)

University -

FOM -

STW 100 %

NWO Other -

Industry -

TNO -

GTI -

EU -

Scholarships -

START OF THE PROJECT

2013

INFORMATION

S Nijdam

040 247 4342

s.nijdam@tue.nl

<http://www.tue.nl/staff/s.nijdam>

PROJECT AIM

New plasma and plasma source technologies will be explored that have the potential to tackle simultaneously the two fundamental problems mentioned in the twinning research projects on EUVL: dust particles and surface contamination. The sources are targeted to be designed such that the plasmas trap debris particles, charge them negatively, and transport them to a desired place in the system. Simultaneously, the plasma is used to etch away the contamination. EMC and emission of radiation, ions, electrons and radicals are targeted to be fully controlled.

PROGRESS

The project has been completed. Important to this research are dusty or complex plasmas: gas discharges that contain particulates with sizes in the nanometer to micrometer range. In this research, the particles are synthesized by the plasma itself, resulting from initial spontaneous polymerization of a reactive feed gas (acetylene, C₂H₂). Subsequent steps are nucleation (clusters solidify, particles are about 5 nm big and charge numbers are low), sudden coagulation (proto-particles lump together, sizes reach 50 nm, particles become highly and permanently negatively charged) and a continued growth (accretion of plasma ions and radicals). "Big" particles charge up negatively because of efficient electron collection. Due to this negative charge, nanoparticles become confined in the bulk of the plasma (until forces such as gravity push or pull them out).

DISSERTATIONS

1. F.M.J.H. van de Wetering, Formation and dynamics of nanoparticles in plasmas, Eindhoven University of technology.

SCIENTIFIC PUBLICATIONS

1. F.M.J.H. van de Wetering, R.J.C. Brooimans, S. Nijdam, J. Beckers, G.M.W. Kroesen, "Fast and interrupted expansion in cyclic void growth in dusty plasma", J. Phys. D: Appl. Phys. 48(3): 035204, 2015.

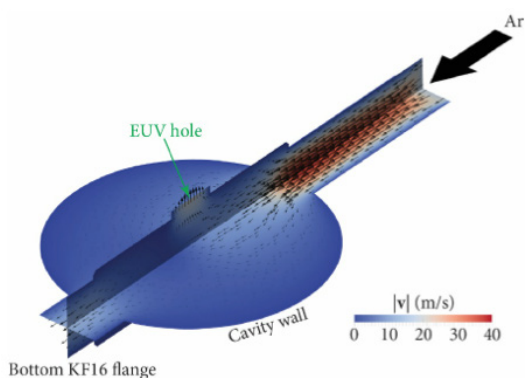

Stream lines (yellow) for argon atoms in one of the four symmetric sections of the cavity. The volume of the EUV beam is visualized as a green translucent cylinder.

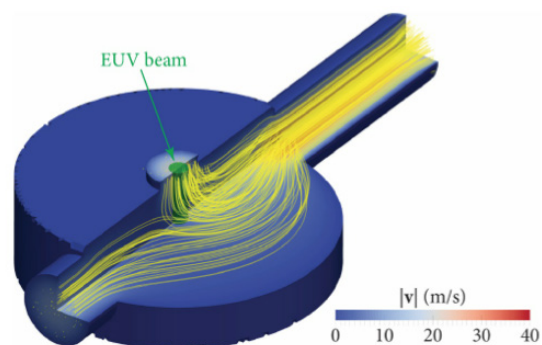

Map of the gas velocity magnitude ($|v|$) for two orthogonal central planes through the cavity. Arrows indicate the local velocity (size proportional to magnitude) and are plotted at every fifth grid point on the planes.

STICK TO THE SURFACE

PROJECT AIM

In EUV lithography tools free floating particles are a cause for concern as they can land on the reticle (mask) where they should be avoided at any cost. However, on any surface inside such a machine there will be dust particles present which can be released by flow and/or plasma conditions. We want to study when and how particles are released from surfaces by (interaction of) flow and plasma under the conditions present in an Extreme-Ultraviolet (EUV) lithography tool and how plasma conditions can directly damage (collector) mirror surfaces in such a tool.

PROGRESS

In EUV lithography tools free floating particles are a cause for concern as they can land on the reticle (mask) where they should be avoided at any cost. However, on any surface inside such a machine there will be dust particles present which can be released by flow and/or plasma conditions. We want to study when and how particles are released from surfaces by (interaction of) flow and plasma under the conditions present in an Extreme-Ultraviolet (EUV) lithography tool and how plasma conditions can directly damage (collector) mirror surfaces in such a tool.

DISSERTATIONS

-

SCIENTIFIC PUBLICATIONS

1. Heijmans, L.C.J. & Nijdam, S. (2015) Plasma particle lofting - Experimental investigation of dust removal force Proceeding of the 27th Symposium Plasma Physics & Radiation Technology, 10-11 March 2015, Lunteren, the Netherlands.
2. Heijmans, L.C.J. & Nijdam, S. (2015). Plasma particle lofting. 68th Annual Gaseous Electronics Conference/9th International Conference on Reactive Plasmas/33rd Symposium on Plasma Processing, 12-16 October 2015, Honolulu, Hawaii (60).
3. Heijmans, L.C.J. & Nijdam, S. (2015). Simulating the charging of a particle on a surface in a plasma. 68th Annual Gaseous Electronics Conference/9th International Conference on Reactive Plasmas/33rd Symposium on Plasma Processing, 12-16 October 2015, Honolulu, Hawaii (60).
4. Heijmans, L.C.J., & Nijdam, S. (2015). Balancing the fluxes : how deposited dust is charged. Proceedings of the 18th Euregional Workshop on the Exploration of Low Temperature Plasma Physics (WELTPP-18 2015), 3-4 December 2015, Kerkrade, The Netherlands.
5. Neelis, T.W.C., Beckers, J.P., Schrader, A.B., Heijmans, L.C.J. & Nijdam, S. (2015). Plasma particle lofting : one million g centrifuge. Proceedings of the 18th Euregional Workshop on the Exploration of Low Temperature Plasma Physics (WELTPP-18), December 3-4, 2015, Kerkrade, The Netherlands, Kerkrade, Netherlands.
6. Leuken, D.P.J. van, Heijmans, L.C.J. & Nijdam, S. (2015). Plasma particle lofting : experimental measurements using vibrations. Proceedings of the 18th Euregional Workshop on the Exploration of Low Temperature Plasma Physics (WELTPP-18), December 3-4, 2015, Kerkrade, The Netherlands, Kerkrade, Netherlands.

PROJECTLEADERS

S Nijdam, J van Dijk, GMW Kroesen

RESEARCHTHEME

Complex dynamics of fluids

PARTICIPANTS

LCJ Heijmans

COOPERATIONS

Together with WDY-group, TU/e. F. Toschi and H.J.H. Clercx with PhD student

FUNDED

STW, ASML	
University	-
FOM	-
STW	62 %
NWO Other	-
Industry	38 %
TNO	-
GTI	-
EU	-
Scholarships	-

START OF THE PROJECT

2013

INFORMATION

S Nijdam
040 247 4342
s.nijdam@tue.nl
<http://www.tue.nl/staff/s.nijdam>

THE SECRETS OF ION WIND

PROJECT LEADERS

S Nijdam

RESEARCH THEME

Complex dynamics of fluids

PARTICIPANTS

S Chen

COOPERATIONS

Together with Turbulence Vortex Dynamics group, TU/e, H.J.H. Clercx and A.P.C. Holten

FUNDED

NWO	
University	-
FOM	-
STW	100 %
NWO Other	-
Industry	-
TNO	-
GTI	-
EU	-
Scholarships	-

START OF THE PROJECT

2015

INFORMATION

S Nijdam
040 247 4342
s.nijdam@tue.nl
<http://www.tue.nl/staff/s.nijdam>

PROJECT AIM

It has been known since many years that cold atmospheric discharges like coronas, streamers and dielectric barrier discharges can induce a gas flow. This effect is generally called corona wind or ion wind. Many groups have investigated corona wind with empiric methods, but insight in the microscopic principles is very limited. The project will make the connection between microscopic quantities like ion drift velocity and macroscopic quantities like flow velocity by investigating them both. This will lead to a detailed understanding of ion wind, thus enabling large steps in the optimization of its applications.

PROGRESS

An experimental set-up is built to generate the ion wind. First the hot-wire anemometry method is chosen to measure the wind velocity from the tube electrode when ion wind pass by. Then ion drift induced flow patterns will be observed by means of shadowgraphy. Plans are made to use particle image velocimetry, used extensively in the Turbulence Vortex Dynamics group of the Applied Physics department to measure the velocity distribution of particles more elaborately.

DISSERTATIONS

-

SCIENTIFIC PUBLICATIONS

-





Prof.dr.ir. NG Deen



Prof.dr. LPH de Goeij



Prof.dr. JGM Kuerten



Prof.dr. M Golombok

The Multiphase & Reactive Flows group is a new group at the Eindhoven University of Technology that replaces the former Combustion Technology and Process Technology groups as of 1 January 2016. The main goal of the group is to gain insight and knowledge in multiphase and reactive flows within the fields of process technology and combustion technology. To this end, the group performs theoretical, numerical and experimental research on selected subjects., ranging from fundamentals to applications. The aims are to contribute to scientific issues relevant to the field, to develop tools for applying scientific results to practical cases and to design equipment using these results. Many research activities are carried out in co-operation with and with support from industry. The main research topics are highlighted below.

1. Combustion

The aim of our studies on reactive flows is the development and improvement of models of combustion systems. The models are used to guide new developments in the struggle to come to more efficient and clean conversion systems of fossil and sustainable fuels for a sustainable society. The knowledge and models developed are based on thorough physical and chemical understanding of the processes. This means that the gap between fundamental and application has to be bridged continuously by transforming models describing physical/chemical behaviour on the smallest scales to models for the macroscopic scale of the full system. The knowledge is based on 'generic' theoretical and numerical insights for the propagation and structure of idealised flames and their interaction with acoustic waves, turbulent structures and inert/reacting surfaces. Most models for the combustion chemistry are based on a combination of the so-called laminar flamelet concept and chemical reduction methods leading to new techniques like FGM. There is also a close relation between theoretical/numerical and experimental research. Available diagnostic techniques are e.g. flame visualisation, absorption techniques, LDV, PIV, LIF and Rayleigh scattering. Validation with the available laser-diagnostic measurement systems in the laboratory and real applications is carried out to disentangle the processes taking place on the various length and time scales. These measurements are carried out in flat (non-)adiabatic flames stabilised on the Heat Flux burner, laminar flames on Bunsen-type burners, flat turbulent flames on a weak-swirl burner, biomass grid, tube and bed reactors, optically-accessible combustion vessels and optically-accessible engines. Application areas are: small-scale laminar combustion systems, combustion of bio-fuels, engines and gas turbines. The application area of combustion engines is of particular interest

2. Turbulent flow

Faster and more efficient numerical methods for DNS and LES models for particle-laden turbulent flow are being developed. Experimental research into inhomogeneous turbulence at intermediate and high Reynolds number is carried out by means of 3D-PTV in turbulent pipe flow.

3. Phase-transitional flow

Fluid flow in which a phase change occurs is of considerable importance in process and combustion technology. The research is focused on boiling, (dropwise) condensation and sublimation. The research is generic, aiming at results that are applicable in numerical methods and for the design of unit operations.

As examples, the dependencies of drag and lift force coefficients on acceleration of bubbles and particles have been studied and the effect of the velocity field caused by condensation directly downstream of the inlet of a confined steam jet on self-similarity has been investigated. Current research focuses on inertia-dominated interaction of flow and bubbles or particles and on basic mechanisms of condensation and sublimation. The approach followed is analytical, experimental and numerical. A multi-scale method, based on and validated by dedicated experiment and numerical simulation, is being developed.

4. Rotating fluid flow

The insights gained in the previous two topics are applied to new concepts of process technology, mainly in the area of rotational equipment and separation devices. These projects are carried out in close cooperation with industry and comprise the design, manufacturing and testing of new equipment.

ENERGY FLOWS OF THE FUTURE, 3PX: THREE POWER CROSSOVER

PROJECT LEADERS

BFW Vermeltfoort, NJ Dam

RESEARCH THEME

Complex dynamics of fluids

PARTICIPANTS

BFW Vermeltfoort, NJ Dam,
LPH de Goey

COOPERATIONS

Liander B.V.

FUNDED

Liander B.V.	
University	1-
FOM	-
STW	-
NWO Other	-
Industry	100 %
TNO	-
GTI	-
EU	-
Scholarships	-

START OF THE PROJECT

2013

INFORMATION

BFW Vermeltfoort
06 31 03 20 26
B.F.W.Vermeltfoort@tue.nl
www.tue.nl/combustion

PROJECT AIM

In this project an innovative concept is studied to combine domestic heating, decentralized electricity generation and mobility.

PROGRESS

Simulations show that by utilizing a plug-in hybrid electric vehicle as a micro-CHP, there is a big potential to decrease greenhouse gas emissions and energy costs with relatively low initial investment. Calculations have shown that this combination is energetically, economically and environmentally positive. In this concept the hybrid car will use natural gas as a fuel to provide the household with heat, electricity and mobility. It is therefore a "bridge" between the three biggest household energy needs. The extra flexibility that this concept delivers can potentially increase the availability of intermittent renewable energy sources. Research will continue to experimentally prove the concept both in laboratory as well as in realistic circumstances. This will give insight in the feasibility of the concept and the effects on the energy grids.

DISSERTATIONS

-

SCIENTIFIC PUBLICATIONS

-

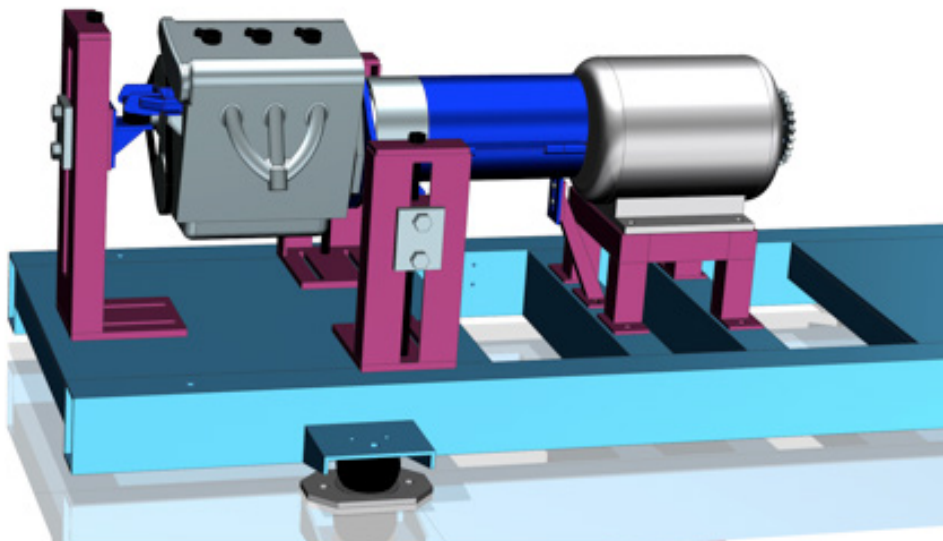

CAD render of the experimental setup; on the left the natural gas engine, on the right the generator

NUMERICAL AND EXPERIMENTAL STUDY OF THERMO-ACOUSTICS OF DOMESTIC BURNER WITH HEAT EXCHANGER

PROJECT AIM

The goal of the project is to investigate the interaction between a burner and a heat exchanger looking from a thermo-acoustic and hydrodynamic point of view. This goal is thought to be achieved by both laboratory and numerical experiments. A laboratory with basic test setups is available to measure the relation between acoustic velocity and heat release. On the numerical front, simple premixed flames are going to be modelled to study this relation. This will be taken as a starting point to research the interaction with a heat exchanger. Finally, design rules need to be defined in order to create this combination in a shorter time span and with minimum thermoacoustic instabilities.

PROGRESS

In the numerical front, the 2D CFD model is developed for inclusion of heat exchanger. Extensive combustion verifications have been performed to ensure correct thermoacoustic properties for a vast variety of conditions, with and without heat exchanger. With the CFD model, it is possible to predict the thermoacoustic behavior of a simplified boiler using the properties of its components for varying distances between them. The results of his investigation have been submitted to the 36th Combustion Symposium (August 2016). A separate publication will also be prepared about the 3D effects in simulating the flame transfer function. Two joint studies with Technische Universität München in Germany and Keele University in England have been performed to investigate this approach using other numerical and analytical tools.

DISSERTATIONS

-

SCIENTIFIC PUBLICATIONS

1. Hosseini, N., Kornilov, V., Teerling, O.J., Arteaga, I.L., de Goeij, L.P.H., "Transfer Function Calculations of Segregated Elements in a Simplified Slit Burner with Heat Exchanger", The 22nd International Congress on Sound and Vibration, 12-16 July 2015, Florence, Italy.
2. Hosseini, N., Kornilov, V., Teerling, O.J., Arteaga, I.L., de Goeij, L.P.H., "Investigating the Effects of Heat Exchanger on Flame Transfer Function in a Simplified Boiler", Combura'15 Combustion Research and Application, 7-8 October 2015, Soesterberg, The Netherlands.

PROJECT LEADERS

LPH de Goeij, NJ Dam, LMT Somers

RESEARCH THEME

Complex dynamics of fluids

PARTICIPANTS

NCJ Maes, NG Deen

COOPERATIONS

Bekaert Combustion Technology

Technische Universität München

Keele University

FUNDED

STW, EC, Bekaert Combustion

Technology

University -

FOM -

STW 7 %

NWO Other -

Industry 18 %

TNO -

GTI -

EU 75 %

Scholarships -

START OF THE PROJECT

2013

INFORMATION

N Hosseini

06 44266732

n.hosseini@tue.nl

www.scm.keele.ac.uk/Tango/tango-network-research-task-3-5

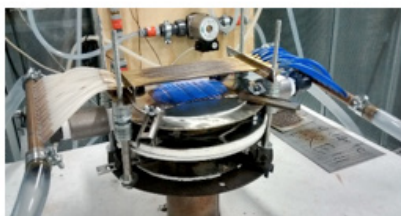

(a)

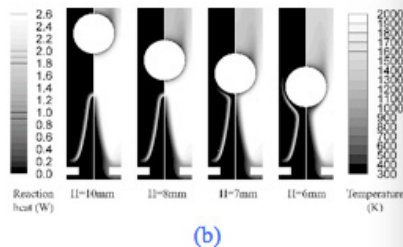

(b)

The experimental setup (a) and simulation results (b)

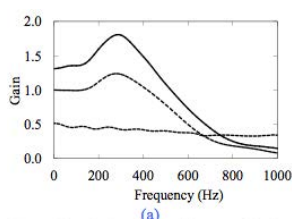

(a)

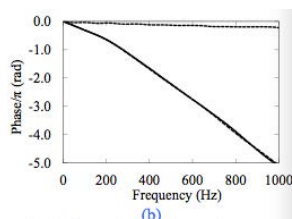

(b)

Gain (a) and phase (b) of the transfer function for the flame, hex, and complete system

TRACKING JOULES: FLAME-WALL INTERACTION IN DIESEL SPRAY COMBUSTION

PROJECT LEADERS

LPH de Goey, NJ Dam, LMT Somers

RESEARCH THEME

Complex dynamics of fluids

PARTICIPANTS

NCJ Maes, NG Deen

COOPERATIONS

Fiat Powertrain Technologies.

FUNDED

University, Fiat Powertrain Technologies.

University 66 %

FOM -

STW -

NWO Other -

Industry 33 %

TNO -

GTI -

EU -

Scholarships -

START OF THE PROJECT

2014

INFORMATION

NCJ Maes

040 247 2877

n.c.j.maes@tue.nl

www.combustion.tue.nl

PROJECT AIM

In a collaboration with Fiat Powertrain Technologies, the effect of flame-wall interaction is studied in detail using optical diagnostic techniques and temperature measurements in a constant volume vessel. The higher goal is to design a completely new, heavy-duty engine based on optimization through modelling. In order to achieve reliable and predictive models, it is essential to perform fundamental and reproducible experiments at relevant conditions to validate such numerical efforts.

PROGRESS

The combustion vessel has been updated to reach heavy-duty conditions relevant to the project. A number of optical diagnostic techniques have been used to characterize free jets at different operating conditions. The study of these free jets is a necessary pre-requisite to understand the impact of wall interaction. The optical diagnostic techniques performed up until now include:

- High-speed Diffused Back-Illumination (DBI) – images liquid fuel penetration (for a non-reacting spray);
- High-speed Schlieren – images gas-phase fuel penetration (for a non-reacting spray);
- High-speed OH* - Images the flame front of the reacting spray;
- CH₂O Laser Induced Fluorescence (LIF) – Images a first stage ignition product.

DISSERTATIONS

-

SCIENTIFIC PUBLICATIONS

-

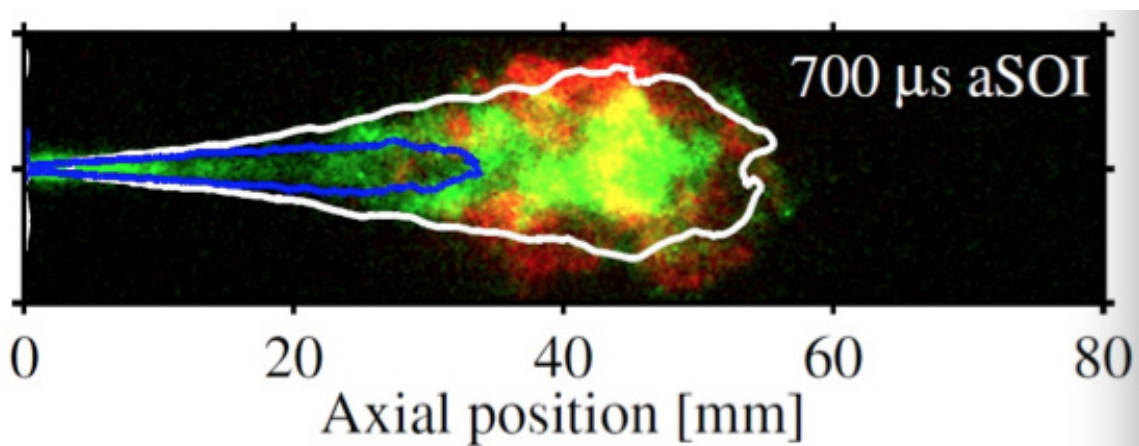

Combination of the performed optical diagnostic techniques. Green and red represent a simultaneous, single-shot recording of CH₂O and OH*, respectively. Yellow consequently shows the regions where they overlap. Blue and white contours illustrate the average liquid and vapor penetration from corresponding non-reacting experiments, shown here at the same time after Start Of Injection (aSOI). Due to combustion, the flame expands beyond the vapor contour of a non-reacting fuel spray.

BiOxyFuel: TORREFIED BIOMASS COMBUSTION UNDER OXY-FUEL CONDITIONS IN COAL-FIRED POWER PLANTS

PROJECT AIM

In this project interaction between different kinds of particles and between particles and flow will be studied in which the properties of the particles, such as size, shape, temperature and chemical composition change in time because of combustion and flow of the surrounding gas. Particles will be treated as point particles, but detailed numerical simulations will be carried out to obtain correlations for the forces on a particle.

PROGRESS

In 2015 the effect of droplet collisions on the properties of droplet-laden turbulent channel flow has been investigated. It has been found that even for overall droplet volume fractions as low as 0.01%, droplet collisions have a large influence on the droplet concentration profile in the channel, resulting in far lower maximum concentration near the wall. The effect of this reduced droplet concentration on the heat transfer in the channel is, however, limited.

DISSERTATIONS

-

SCIENTIFIC PUBLICATIONS

1. J.G.M. Kuerten, A.W. Vreman, Effect of droplet interaction on droplet-laden turbulent channel flow, Phys. Fluids 27, 053304 (2015).

PROJECTLEADERS

JGM Kuerten

RESEARCHTHEME

Complex dynamics of fluids

PARTICIPANTS

AW Vreman, JGM Kuerten

COOPERATIONS

AKZO Nobel

FUNDED

TU/e

University 100 %

FOM -

STW -

NWO Other -

Industry -

TNO -

GTI -

EU -

Scholarships -

START OF THE PROJECT

2010

INFORMATION

JGM Kuerten

040 247 2362

j.g.m.kuerten@tue.nl

www.wtb.tue.nl/woc/ptc

CFD MODELING FOR THE OPTIMIZATION OF A FLAME IONIZATION SENSOR

PROJECT LEADERS

JA van Oijen

RESEARCH THEME

Complex dynamics of fluids

PARTICIPANTS

JA van Oijen, N Speelman

COOPERATIONS

-

FUNDED

Bosch Thermotechniek BV

University -

FOM -

STW -

NWO Other -

Industry 100 %

TNO -

GTI -

EU -

Scholarships -

START OF THE PROJECT

2010

INFORMATION

JA van Oijen

040 247 3133

j.a.v.oijen@tue.nl

www.tue.nl/combustion

PROJECT AIM

The purpose of this research is to develop a combustion control and diagnostics sensor based on flame ionization for condensing boiler applications. The flame ionization sensor measures the electrical conduction of the charged species generated during the combustion process to detect flashback and combustion instabilities, and to monitor equivalence ratio. In particular, the focus is on developing models to integrate the electric field emanating from the electrode with the lean premixed combustion process and ion reaction/transport submodels to simulate the electrode test results and optimize its position and shape.

PROGRESS

During the previous year the numerical model was finalized and it was validated against experimental observations. It was found that the model performed well qualitatively and that all features of the voltage-current characteristic were represented by the model. To improve the quantitative agreement, the chemical mechanism was optimized. Using the optimized mechanism excellent agreement was found for a wide range of conditions (see Figure).

The model was furthermore used to simulate time-dependent flames in AC electric fields, which were studied experimentally. The observed unsteady effects were reproduced by the model.

DISSERTATIONS

1. Speelman, N. (2015). Model development for ionization phenomena in premixed laminar flames. Eindhoven: Technische Universiteit Eindhoven. ((Co-)promotor: prof.dr. L.P.H. de Goeij & dr.ir. J.A. van Oijen).

SCIENTIFIC PUBLICATIONS

1. Speelman, N., Kiefer, M., Markus, D., Maas, U., Goeij, L.P.H. de & Oijen, J.A. van (2015). Validation of a novel numerical model for the electric currents in burner-stabilized methane-air flames. *Proceedings of the Combustion Institute*, 35(1), 847-854.
2. Speelman, N., Goeij, L.P.H. de & Oijen, J.A. van (2015). Development of a numerical model for the electric current in burner-stabilised methane-air flames. *Combustion Theory and Modelling*, 19(2), 159-187.

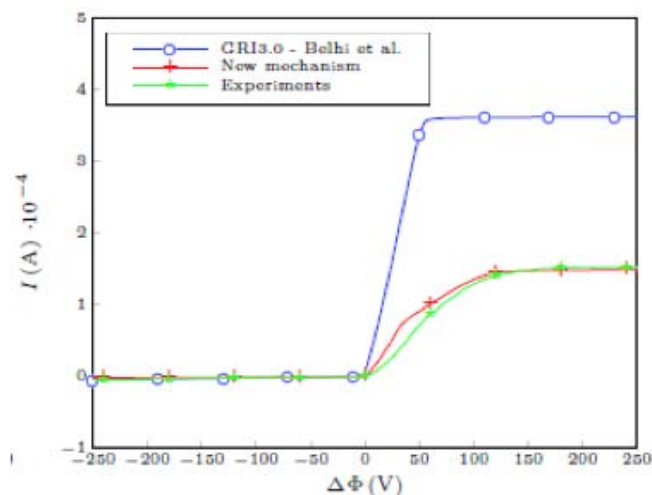

Voltage-current characteristic for a flat premixed methane-air flame

PARTICLE-PARTICLE INTERACTION IN BIOMASS CO-FIRING POWER PLANTS

PROJECT AIM

A computational method will be developed to simulate the combined combustion of biomass and coal in biomass co-fired power plants. Realistic operation conditions of power plants involve particle volume fractions (typically 3×10^{-4}) that require incorporation of two-way interaction between particles and surrounding gas in terms of mass, momentum and energy, and particle-particle interaction by radiative heat transfer. The model would enable optimization of the combustion time, ash quality and emissions of the power plant by varying the particle composition and size. Effects of increased biomass fraction on the process efficiency will be quantified.

PROGRESS

An earlier DNS model with pyrolysis and combustion of biomass particle was extended by including gas phase reaction. These include combustion reactions of gases and water gas shift reaction. Effects of including gas phase reactions on the conversion time of biomass particles were studied. Effect of particle size and particle volume fraction on conversion time was also analyzed. The conversion time of biomass particles is sensitive to their diameter and increases for larger particles. The effect of two-way coupling is higher for smaller particles due to the higher total heat exchange area in case of small particles.

DISSERTATIONS

-

SCIENTIFIC PUBLICATIONS

1. A. Awasthi, J.G. M. Kuerten, B. J. Geurts, simulation of biomass combustion in turbulent channel flow, Conference paper: Proceedings of the 8th Turbulence, heat and mass transfer conference, Begell House, 2015, (pp. 833-836).

PROJECT LEADERS

JGM Kuerten

RESEARCH THEME

Complex dynamics of fluids

PARTICIPANTS

A Awasthi, JGM Kuerten

COOPERATIONS

BJ Geurts (UT), SHELL

FUNDED

FOM, Shell	
University	-
FOM	100 %
STW	-
NWO Other	-
Industry	-
TNO	-
GTI	-
EU	-
Scholarships	-

START OF THE PROJECT

2013

INFORMATION

A Awasthi
06 87 36 27 54
A.Awasthi@tue.nl
www.wtb.tue.nl/woc/ptc

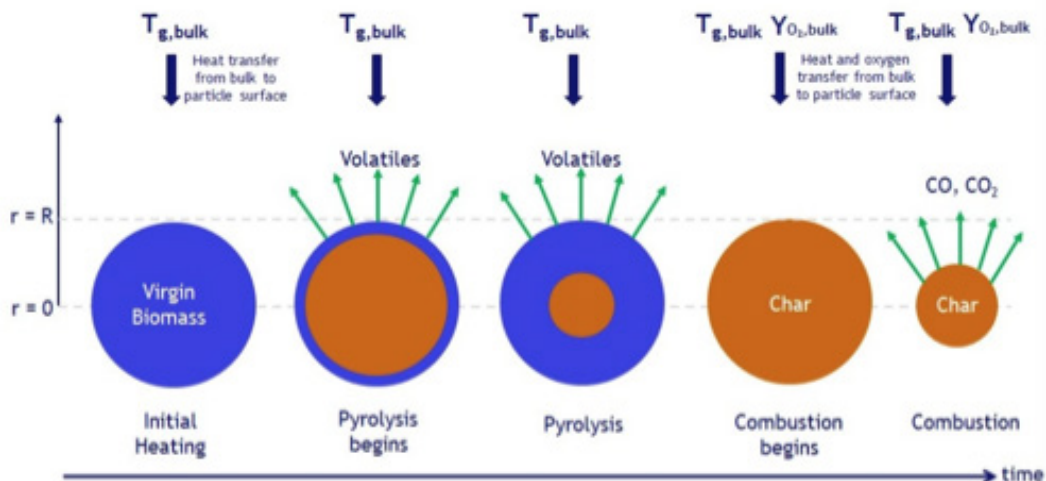

MOBILISING HEAVY HYDROCARBONS

PROJECT LEADERS

M Golombok, MD Boot, LPH de Goey

RESEARCH THEME

Complex structures of fluids

PARTICIPANTS

M Cuijpers, M Golombok, MD Boot, J Hasker, F Seegers, M Willekens, J van Santvoort, NG Deen

COOPERATIONS

Shell

FUNDED

Shell	
University	-
FOM	-
STW	-
NWO Other	-
Industry	100 %
TNO	-
GTI	-
EU	-
Scholarships	-

START OF THE PROJECT

2014

INFORMATION

M Cuijpers
040 247 3591
m.c.m.cuijpers@tue.nl
www.combustion.tue.nl

PROJECT AIM

The average recovery of an oil well has been estimated at approximately 70%, partially due to the high viscosity of the remaining heavy hydrocarbons. Subcritical water (SCW) has been shown to effectively reduce the viscosity of these heavy hydrocarbons in two ways. Firstly, the dielectric constant of water is decreased, enabling the solution of heavy oil components. Simultaneously, the dissociation constant of the medium enhanced the cracking of heavy hydrocarbons into lighter components. Reductions up to 80% have been observed and could be achieved within a few hours. A better understanding of the chemical source of the viscosity reduction could be achieved by looking more closely into SCW.

PROGRESS

Therefore, this project is focused on the chemical source of the permanent viscosity reduction, by comparing the chemical structure of pre- and post-processed heavy hydrocarbons. SCW experiments and GCxGC SCD - FID analysis of both the feed and the product have demonstrated that the average carbon chain length was reduced. Moreover, GPC data indicated a decrease in the molecular weight, whereas elemental analysis showed a 26% decrease in sulphur.

DISSERTATIONS

-

SCIENTIFIC PUBLICATIONS

-

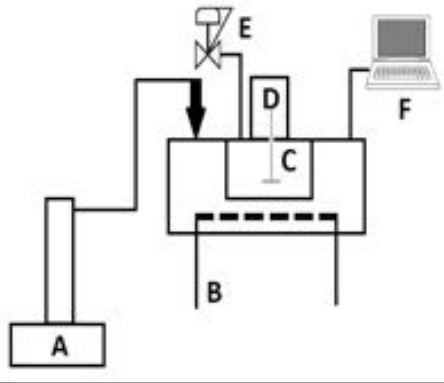

Show a schematic and realistic overview of the subcritical water setup for analyzing different operating conditions on varying heavy oil and water samples. Consisting of: An Isco high pressure syringe pump; B electric heating mantle, C Premex autoclave; D magnetic stirrer; E pressure control; F data-acquisition

FATE OF FORGOTTEN FUEL

PROJECT AIM

Investigation of the burn-out phase: the late combustion of "forgotten fuel", left-overs from the main heat release in the classical diesel combustion (CDC) regime. Numerical part of the project will focus on testing and extending the Flamelet-Generated Manifold (FGM) approach towards the burn-out phase. For that purpose; FGM method will be applied in a Large-Eddy Simulation (LES) approach and validation studies will be performed for spray A and optical engine (D5) cases.

PROGRESS

FGM chemistry solutions are validated against detailed chemistry ones for 1D igniting counterflow flames with spray-A like conditions. Since FGM tables are generated at a given strain rate the method predicts ignition delay accurately at that precise strain rate. Its accuracy decreases as the strain rate changes. So, multiple FGM tables are generated at various strain rate and by interpolating between these tables, good accuracy is obtained for 1D case over the whole range (up to the ignition limit). A LES of spray-A is performed by using FGM chemistry. Numerical results agree qualitatively with the experimental data, but more simulations are needed to obtain better averaged fields. Also, initial results suggest an investigation of the effect of strain rate for spray-A LES in line with the findings for the counterflow flames.

DISSERTATIONS

-

SCIENTIFIC PUBLICATIONS

-

PROJECT LEADERS

LMT Somers, NJ Dam, LPH de Goey

RESEARCH THEME

Mathematical and computational methods for fluid flow analysis

PARTICIPANTS

HY Akargün, PC Bakker,
LMT Somers, NJ Dam,
BH Johansson

COOPERATIONS

DAF Trucks, TNO, Delphi, Shell
Global Solutions

FUNDED

STW, Shell Global Solutions
University -
FOM -
STW 51 %
NWO Other -
Industry 49 %
TNO -
GTI -
EU -
Scholarships -

START OF THE PROJECT

2014

INFORMATION

HY Akargun
06 30 36 89 17
h.y.akargun@tue.nl
www.tue.nl/combustion

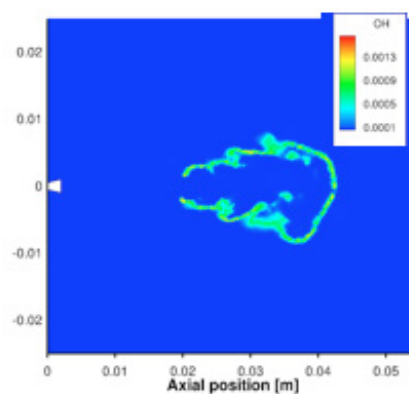
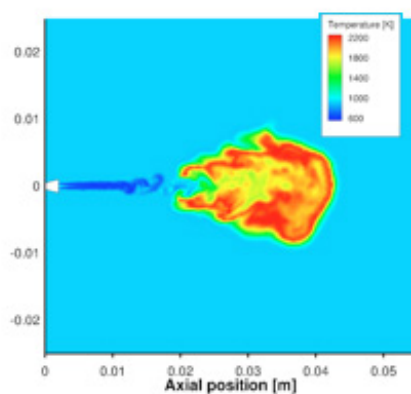

LES of spray-A condition (ECN) with FGM chemistry at 1 ms and strain rate of 500 s⁻¹: contour slices of temperature (left) and OH mass fraction (right)

HEAT2CONTROL

PROJECT LEADERS

FPT Willems, LMT Somers,
LPH de Goey, M Steinbuch

RESEARCH THEME

Mathematical and computational
methods for fluid flow analysis

PARTICIPANTS

B Akkurt, LMT Somers, X Luos,
F Willems

COOPERATIONS

DAF Trucks, Sensata, TNO, Delphi

FUNDED

STW, DAF, Sensata, TNO, Delphi

University	-
FOM	-
STW	63,5 %
NWO Other	-
Industry	17 %
TNO	19,5 %
GTI	-
EU	-
Scholarships	-

START OF THE PROJECT

2014

INFORMATION

B Akkurt
06 41 40 18 33
b.akkurt@tue.nl
www.tue.nl/combustion

PROJECT AIM

This research project focuses on the development of new modeling technique for high EGR diesel combustion concepts with multiple injection fueling systems, which is seen as an essential step towards future RCCI concepts. The CFD-FGM model, which will be extended for multi-pulse injection strategies, will be validated with experimental data.

PROGRESS

The first interest of combustion modeling in this project is to validate the FGM method for combustion modeling of a double injection Spray-A case from the Engine Combustion Network (ECN). To model the non-reacting case is a necessary step for spray model before implementing the reaction. The figure shows how accurate the fuel vapor penetration is modeled numerically. The next, currently on going, step is adding combustion to validate the FGM table for accurate combustion modeling and the capability of the CFD solver to interact with the FGM methodology. Currently the CFD solver is being adapted to use FGM.

DISSERTATIONS

-

SCIENTIFIC PUBLICATIONS

-

MODELING DRYING DROPLETS ON POROUS SUBSTRATES

PROJECT AIM

The aim of this research is to generalize an existing model for the evolution of a sessile ink droplet subject to evaporation and absorption into a porous substrate by three further aspects:

(1) the model will be extended to incorporate the presence and influence of surfactants;

(2) to investigate the impact of neighboring droplets, a generalization to three dimensions is proposed;

(3) the absorption into the porous substrate will be extended to comprise more general types of porous substrates.

PROGRESS

The model has been generalized to account for the evaporation and absorption of multi-component droplets. To that end, the evaporation rate of a mixture droplet has been derived based on first principles and a corresponding analytical solution was found. The complicated interplay of preferential evaporation, convective and diffusive transport and the composition-dependence of the fluid properties – namely mass density, viscosity, diffusivity, surface tension and thermodynamic activity – were encompassed in a novel multi-component lubrication theory. Representative simulations have been carried out with binary water-ethanol and water-glycerol mixtures as well as with ternary mixtures.

DISSERTATIONS

-

SCIENTIFIC PUBLICATIONS

-

PROJECTLEADERS

JGM Kuerten

RESEARCHTHEME

Complex dynamics of fluids

PARTICIPANTS

C Diddens, CWM van der Geld, HMA Wijshoff, JGM Kuerten

COOPERATIONS

Océ

FUNDED

STW, Océ	
University	-
FOM	-
STW	58,6 %
NWO Other	-
Industry	41,4 %
TNO	-
GTI	-
EU	-
Scholarships	-

START OF THE PROJECT

2014

INFORMATION

JGM Kuerten

040 247 2362

j.g.m.kuerten@tue.nl

www.wtb.tue.nl/woc/ptc

DBD-PLASMA ASSISTED COMBUSTION

PROJECT LEADERS

V Kornilov, JA van Oijen,
LPH de Goey

RESEARCH THEME

Complex dynamics of fluids

PARTICIPANTS

A Elkholy

COOPERATIONS

CWI's research group (Ute Ebert)
Physics department in TUE (Sander
Nijdam)

FUNDED

Egyptian government
University -
FOM -
STW -
NWO Other -
Industry -
TNO -
GTI -
EU -
Scholarships 100 %

START OF THE PROJECT

2014

INFORMATION

A Elkholy
040 247 3621
A.Elkholy@tue.nl
www.combustion.tue.nl

PROJECT AIM

The aim of the project is to investigate experimentally low temperature plasma-flame interaction for CH₄ premixed flame in a flat flame burner with a dielectric barrier discharge (DBD) Plasma technique. We desire to investigate the effect of RF (radio frequency) plasma on flame stabilization, emissions, CH₄ oxidation rate, radical and ion formation and their effect on flame propagation speed.

PROGRESS

- Design and construction of CH₄ flat flame burner.
- Design and construction of dielectric barrier discharge (DBD) plasma generator which consisting of disk electrodes, pulse generator, signal amplifier and oscilloscope.
- Studying different holes patterns to get the suitable plasma discharge inside/around the holes.

DISSERTATIONS

-

SCIENTIFIC PUBLICATIONS

-

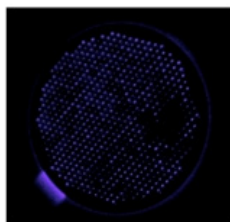
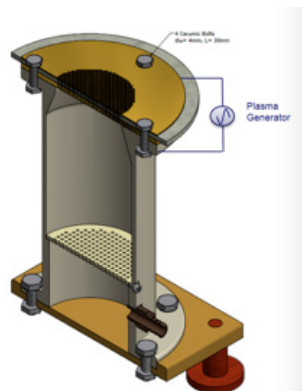
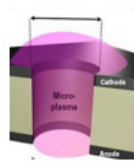

300Hz - 4 kV

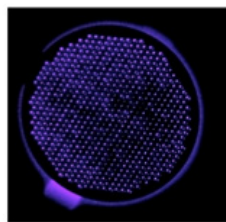

1kHz - 4 kV

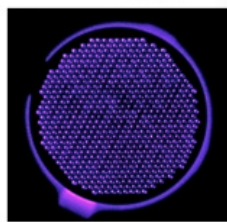

3.5kHz - 4 kV

Plasma generation in the reactor at different operating conditions

FATE OF FORGOTTEN FUEL

PROJECT AIM

Diesel engines lose valuable efficiency points because of the relatively long burn-out phase. To study this in more detail, sophisticated laser diagnostic techniques will be developed and applied. The goal is to provide an improved fundamental understanding of the fate of this late-burning fuel, to improve engine efficiency by more economic use of the injected fuel, and to complete the last steps towards a full numerical engine combustion model (other PhD).

PROGRESS

Throughout the last year the development of several techniques has been started. The aim was to study soot and CO, both in the late phase, and in engine conditions. The development of two-photon CO laser-induced fluorescence ($2 \times 230.1 \text{ nm}$) is still ongoing, whereas the laser-induced incandescence technique (using a high-speed Nd:YAG at its fundamental wavelength) was applied successfully in an engine environment. Ultimately, both techniques will be used to benchmark and compare fuels in terms of their late phase burning behavior.

DISSERTATIONS

-

SCIENTIFIC PUBLICATIONS

1. Bakker, P.C., Willems, R.C. & Nico Dam (2016). Implementation of High-Speed LaserInduced Incandescence Imaging in CI Engines. Accepted for publication as SAE Technical Paper.

PROJECTLEADERS

LMT Somers, NJ Dam

RESEARCHTHEME

Complex dynamics of fluids

PARTICIPANTS

PC Bakker, HY Akargün,
LMT Somers, NJ Dam,
BH Johansson, NG Deen

COOPERATIONS

DAF Trucks, TNO, Delphi,
Shell Global Solutions

FUNDED

STW, SHELL Global Solutions
University -
FOM -
STW 50 %
NWO Other -
Industry 50 %
TNO -
GTI -
EU -
Scholarships -

START OF THE PROJECT

2013

INFORMATION

PC Bakker
040 247 5995
p.c.bakker@tue.nl
www.tue.nl/combustion

Example of visible CO fluorescence in our lab (left). Photo courtesy of Robin Doddema. Still image of HS-LII sequence in the engine (right). A full movie of the corresponding natural luminosity can be seen upon scanning the QR-code.

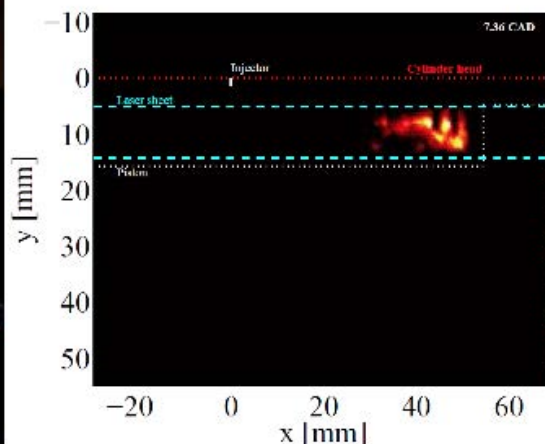
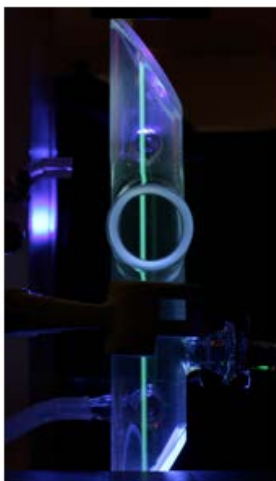

DEVELOPMENT OF RELIABLE EMISSION AND ATOMIZATION MODELS FOR COMBUSTOR DESIGN

PROJECT LEADERS

JA van Oijen, LPH de Goey,
RJM Bastiaans

RESEARCH THEME

Mathematical and computational methods for fluid flow analysis

PARTICIPANTS

DV Efimov

COOPERATIONS

Rheinisch-Westfälische Technische Hochschule Aachen. Karlsruher Institut für Technologie. Imperial College of Science, Technology and Medicine.

FUNDED

EU, University	
University	25 %
FOM	-
STW	-
NWO Other	-
Industry	-
TNO	-
GTI	-
EU	75 %
Scholarships	-

START OF THE PROJECT

2013

INFORMATION

JA van Oijen
040 247 3133
j.a.v.oijen@tue.nl
www.tue.nl/combustion

PROJECT AIM

Aim of this project is to develop an accurate and reliable computational tool for prediction of emissions in a lean burn combustion systems for civil aerospace applications. Within this project, the research carried out by TU/e will concentrate on the chemistry reduction method Flamelet-Generated Manifold (FGM), which is intended to reduce the computational cost of the complex chemistry models for application in CFD codes. Improved flamelet tabulation techniques are to be developed focusing on accurate prediction of CO, UHC, NOx and soot emissions from gas turbine combustors.

PROGRESS

Detailed chemistry 1D flame calculations including mimicked isentropic expansion in the post flame zone (process encountered in gas turbine stator). Preliminary validation of FGM tabulated chemistry model, utilizing enthalpy and pressure as additional controlling variables (to account for stator conditions), against aforementioned 1D detailed chemistry cases.

DISSERTATIONS

-

SCIENTIFIC PUBLICATIONS

-

EFFECTS OF PRESSURE ON COMBUSTION CHARACTERISTICS OF CELLULAR HYDROGEN FLAMES

PROJECT AIM

Hydrogen is expected to play an important role in future energy production, especially for the fuel of gas turbine engines. However, there are gaps in the fundamental understanding of hydrogen combustion characteristics at normal and elevated pressures due to the high diffusivity, high reactivity of hydrogen. The aim of the project is to investigate the combustion characteristics of cellular hydrogen flames at elevated pressures.

PROGRESS

1. 2D laminar freely-propagating flames of hydrogen/air mixture were simulated at elevated pressure and temperature.
2. The flames near the lean limit at elevated pressures were experimentally and numerically investigated.

DISSERTATIONS

-

SCIENTIFIC PUBLICATIONS

-

PROJECT LEADERS

RJM Bastiaans

RESEARCH THEME

Complex dynamics of fluids

PARTICIPANTS

Z Zhou, Y Shoshin

COOPERATIONS

-

FUNDED

Chinese Scholarship council

University -

FOM -

STW -

NWO Other -

Industry -

TNO -

GTI -

EU -

Scholarships 100 %

START OF THE PROJECT

2013

INFORMATION

Z Zhou

040 247 5995

Z.Zhou1@tue.nl

www.tue.nl/combustion

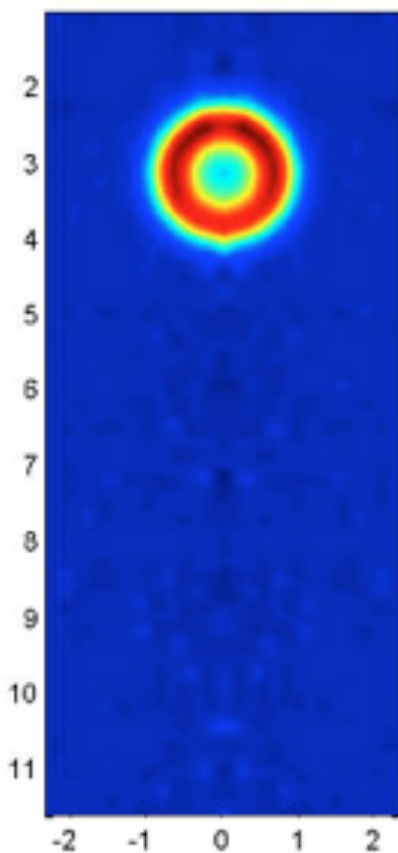

Flame ball at 2 bar.

BOILING FLOW REGIME MAPS FOR SAFE DESIGNING

PROJECT LEADERS

CWM van der Geld, JGM Kuerten,
BJ Geurts

RESEARCH THEME

Complex dynamics of fluids

PARTICIPANTS

G Priems, P Cifani, W Michalek,
C van der Geld, J Kuerten, B Geurts

COOPERATIONS

UT, Stork, NEM, NRG

FUNDED

Stork Thermeq, NEM, NRG

University	-
FOM	-
STW	78 %
NWO Other	-
Industry	22 %
TNO	-
GTI	-
EU	-
Scholarships	-

START OF THE PROJECT

2013

INFORMATION

CWM van der Geld
040 247 2923
c.w.m.v.d.geld@tue.nl
www.tue.nl.

PROJECT AIM

The intended main results of this project are twofold: (1) flow pattern maps for heated two-phase flows, of water-steam and of the model system HFE7000 and its vapor, and (2) a multi-scale numerical method to determine such flow pattern maps which is validated for the measurement conditions for which these maps have been established.

PROGRESS

Giel Priems finished the design of test rig and a new type of local void probe and ordered equipment and arranged fabrication. P. Cifani prepared a first journal paper, focused at systematic testing of interface deformation simulation; he will present VOF simulations with Open Foam at two conferences around summer 2016. W. Michalek modeled interfacial mass transfer successfully in Fluent, with a method based on the energy equation, and will now revert to Open Foam simulation of nucleation.

DISSERTATIONS

-

SCIENTIFIC PUBLICATIONS

-

EFFECTS OF CROSS-SECTION VARIATION AND BUBBLE-BUBBLE INTERACTION ON BUBBLE DETACHMENT IN CONVECTIVE FLOW

PROJECT AIM

The effect of flow on boiling bubble detachment from a heated plane wall is investigated for the effects mentioned in the title. Experiments serve to validate a model based on the diffuse interface method that will be further developed.

PROGRESS

Measurements were finished in 2014. Boundary conditions for the diffuse interface model have been further developed. This has resulted in the simulation of nucleation of boiling bubbles at a solid wall in a cross flow, their subsequent growth and detachment from the wall for arbitrary contact angle between the wall and the bubble. In this way both hydrophobic and hydrophilic walls can be tackled.

DISSERTATIONS

-

SCIENTIFIC PUBLICATIONS

1. C.H.M. Baltis and C.W.M. van der Geld, Heat transfer mechanisms of a vapor bubble growing at a wall in saturated upward flow, *J. Fluid Mech.* 771, 264-302, (2015).
2. C.W.M. van der Geld, C.H.M. Baltis and G.J.M. Priems, Forces in rapid vapor bubble growth in forced convection with varying angle of inclination; 9th International Conference on Boiling and Condensation Heat Transfer, April 26-30, 2015, Boulder, USA.

PROJECTLEADERS

CWM van der Geld, JGM Kuerten

RESEARCHTHEME

Complex dynamics of fluids

PARTICIPANTS

C Baltis, J Desmarais,
CWM van der Geld, JGM Kuerten

COOPERATIONS

DAF, Spirotech B.V.

FUNDED

STW	
University	-
FOM	-
STW	100 %
NWO Other	-
Industry	-
TNO	-
GTI	-
EU	-
Scholarships	-

START OF THE PROJECT

2010

INFORMATION

CWM van der Geld
040 247 2923
c.w.m.v.d.geld@tue.nl
www.tue.nl

ULTRA EFFICIENT CLEAN COMBUSTION CONCEPTS AND THEIR FUEL APPETITE

PROJECT LEADERS

LPH de Goey, LMT Somers

RESEARCH THEME

Complex dynamics of fluids

PARTICIPANTS

S Wang

COOPERATIONS

-

FUNDED

China Scholarship Council

University -

FOM -

STW -

NWO Other -

Industry -

TNO -

GTI -

EU -

Scholarships 100 %

START OF THE PROJECT

2013

INFORMATION

S Wang

040 247 5995

S.Wang@tue.nl

www.tue.nl/combustion

PROJECT AIM

The most prominent characteristics of new combustion modes is the requirement of creating a controllable stratified mixture prior to ignition. Because of the important impacts of fuel physical and chemical properties on the ignition and combustion process, fuel design has become a common approach for the control of ignition timing and combustion rate in advanced combustion modes, such as Partially Premixed Combustion (PPC). Our goal is to conduct an intensive study on PPC using various blends which all have a research octane number around 70, to investigate their combustion and emission characteristics. Moreover, we investigate how particulate number concentrations and size distributions change under different experimental conditions using the selected blends.

PROGRESS

- In order to optimize combustion, a new injector and piston have been installed.
- Several blends all have a research octane number around 70 have been tested on a modified heavy duty diesel engine.
- The selected blends can achieve PPC under low and medium loads through using a good combination of lambda and EGR to reduce exhaust emissions and improve thermal efficiency.

DISSERTATIONS

-

SCIENTIFIC PUBLICATIONS

1. Wang, S., Bakker, P. C., Somers, L. M. T., & de Goey, L. P. H. (2015). Effect of Air-excess on Blends of RON70 Partially Premixed Combustion. *Flow, Turbulence and Combustion*. doi:10.1007/s10494-015-9685-2.
2. Luo, X., Wang, S., Jager, B. de, & Willems, F. (2015). Cylinder Pressure-based Combustion Control with Multi-pulse Fuel Injection. *IFAC-PapersOnLine*, 48(15), 181–186. doi:10.1016/j.ifacol.2015.10.026.
3. Wang, S., De Visser, A.J.M. & Somers, L.M.T. (2015). Experimental Study on Low Temperature and Diesel Conventional Combustion by fueling blends of RON70. Poster : Proceedings of the 7th European Combustion Meeting (ECM 2015), March 29- April 2, 2015, Budapest, Hungary.

WORLD'S ACCURATE FLAME STRETCH THEORY

PROJECT AIM

The dynamics of a premixed flame front is governed by its local propagation speed, i.e. the burning velocity which is affected by the interaction of the flame front with surrounding flow. These interactions are cumulatively referred to as "flame stretch." It becomes mandatory to model these effects accurately as they impact the mass burning rate of the flame. Hence an accurate flame stretch model has to be developed both numerically and mathematically to make accurate prediction of flame dynamics.

PROGRESS

Premixed flames in a stagnation counter-flow, where the jets of mixture collide from opposite sides, was chosen to study flame stretch effects. These flames when subjected to oscillating flow straining, showed many non-linear and unsteady effects. Unsteady stretch effects were predominantly caused by thickness variations of the flame. These unsteady stretch effects were found to affect the stability and quenching of the flames at high strain rates.

DISSERTATIONS

-

SCIENTIFIC PUBLICATIONS

1. A.G. Iyer, J. A. van Oijen, J.H.M ten Thije Boonkamp, L.P.H de Goeij, Effect of flame thickness variation on the mass burning rate of premixed counterflow flames with an oscillating strain rate, Combustion Theory and Modelling, Dec 2015.

PROJECTLEADERS

LPH de Goeij, JA van Oijen,
JHM ten Thije Boonkamp

RESEARCHTHEME

Mathematical and computational
methods for fluid flow analysis

PARTICIPANTS

AG Iyer

COOPERATIONS

-

FUNDED

STW Simon Stevin	
University	-
FOM	-
STW	100 %
NWO Other	-
Industry	-
TNO	-
GTI	-
EU	-
Scholarships	-

START OF THE PROJECT

2011

INFORMATION

JA van Oijen
040 247 3133
j.a.v.oijen@tue.nl
www.tue.nl/combustion

LIGNIN DERIVED FUELS AS OCTANT BOOSTER

PROJECT LEADERS

LPH de Goey, MD Boot

RESEARCH THEME

Complex dynamics of fluids

PARTICIPANTS

M Tian, NG Deen

COOPERATIONS

-

FUNDED

China Scholarship Council (CSC)

University -

FOM -

STW -

NWO Other -

Industry -

TNO -

GTI -

EU -

Scholarships 100 %

START OF THE PROJECT

2012

INFORMATION

M Tian

040 247 2877

m.tian@tue.nl

www.combustion.tue.nl

PROJECT AIM

In this PhD project we reverse engineer, from the engine's perspective, which compounds should ideally be added to conventional fossil fuels to arrive at a more favorable overall engine performance (i.e. in terms of fuel economy and emissions). Second, a production route from biomass should be developed to produce these desired compounds from biomass. This project builds further on existing knowledge that so-called cyclic oxygenates should be targeted, specifically from lignin, a renewable waste-stream available in large volumes in the paper industry.

PROGRESS

Lignin model fuels (anisole, guaiacol and their alkylated compounds) have been tested on a VolvoT5 SI engine. A detailed chemical kinetic model of 4-Methyl anisole oxidation has been made in collaboration with the University of Lorraine. The results show a relatively good agreement with the IQT results and underline that aromatic oxygenates made from biomass are excellent octane boosters.

DISSERTATIONS

-

SCIENTIFIC PUBLICATIONS

1. Tian, M., Van Haaren, R., Reijnders, J., and Boot, M., "Lignin Derivatives as Potential Octane Boosters," SAE Int. J. Fuels Lubr. 8(2):2015, doi: 10.4271/2015-01-0963.

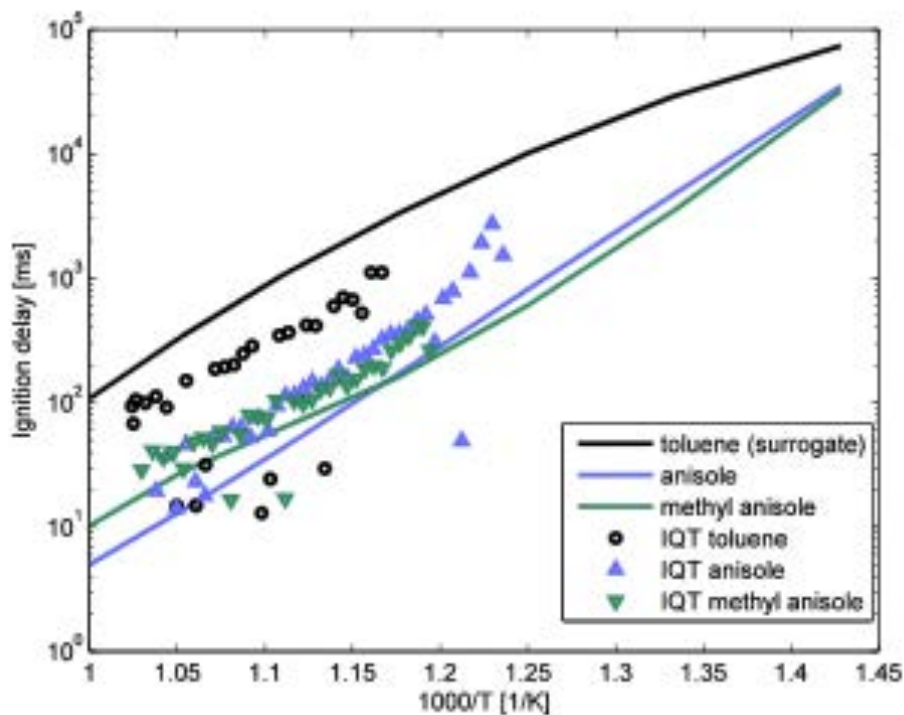

A NOVEL MARINE BIO-FUEL: PROOF OF CONCEPT TO MARKET PROVEN

PROJECT AIM

The assignment of this PhD position is to develop and elaborate all technical and commercial issues related to the use of lignin and/or other potential biomass waste streams as marine fuel, resulting in market ready marine biofuel at the end of the project. An important part of this assignment is to extensively elaborate on the relation between research innovations and knowledge valorization in business, giving guidance to future research projects on how to exploit their inventions.

PROGRESS

- Literature study, getting familiar with matter and playing field
- Stationary tests and engine tests of a selection of fuel samples.
- Contribute to ongoing projects related to such biofuels.

DISSERTATIONS

-

SCIENTIFIC PUBLICATIONS

-

PROJECTLEADERS

MD Boot

RESEARCHTHEME

Complex structures of fluids

PARTICIPANTS

J Feijen, MD Boot, LPH de Goey,
NG Deen

COOPERATIONS

Progression Industry

FUNDED

TU/e	
University	100 %
FOM	-
STW	-
NWO Other	-
Industry	-
TNO	-
GTI	-
EU	-
Scholarships	-

START OF THE PROJECT

2015

INFORMATION

J Feijen
040 247 3591
j.feijen@tue.nl
www.combustion.tue.nl

Biofuel spray combustion at marine engine like conditions

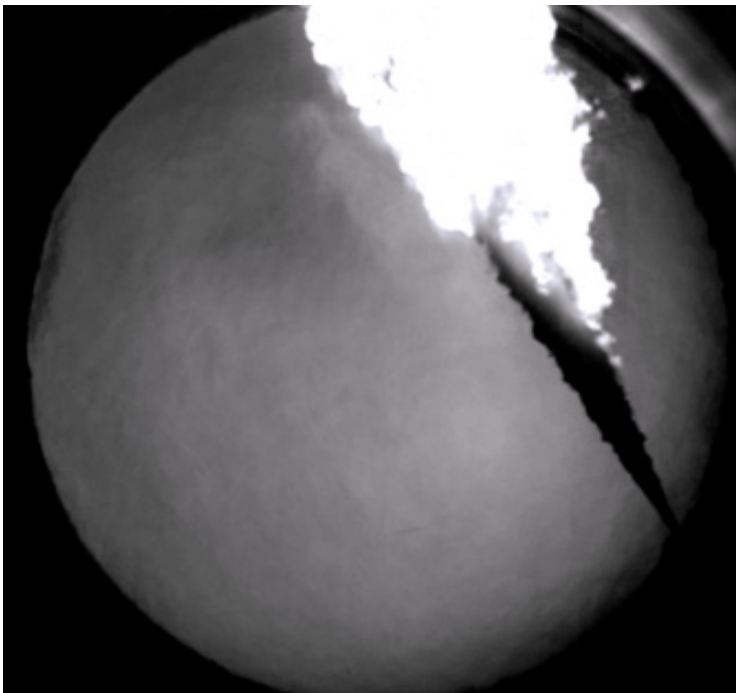

FUEL AND COMBUSTION STRATIFICATION STUDY OF PARTIALLY PREMIXED COMBUSTION USING ADVANCED LASER DIAGNOSTIC TECHNIQUES

PROJECT LEADERS

LMT Somers, NJ Dam,
BH Johansson

RESEARCH THEME

Complex dynamics of fluids

PARTICIPANTS

M Izadi Najafabadi, LMT Somers,
NG Deen

COOPERATIONS

Lund University, Imperial College
London, Shell Global Solutions

FUNDED

ECCO-MATE, Marie Curie Actions

University	-
FOM	-
STW	-
NWO Other	-
Industry	-
TNO	-
GTI	-
EU	100 %
Scholarships	-

START OF THE PROJECT

2014

INFORMATION

M Izadi Najafabadi
040 247 5995
m.izadi.najafabadi@tue.nl
www.tue.nl/combustion

PROJECT AIM

- Better understanding of the concept of Partially Premixed Combustion by investigation of fuel and thermal stratification during this phenomenon.
- Application of different laser diagnostic techniques in a light duty optical engine.
- Accurate quantification of laser diagnostic technique's outcomes in creative manners.
- Successive sharing of experimental results to help other researchers particularly numeric ones

PROGRESS

- Literature review on the implementation of laser diagnostic techniques and partially premixed combustion.
- Preparation and calibration of the engine test cell instruments and the Volvo D5 optical engine setup.
- Investigation of the injection process and spray penetration by using high-speed Shadowgraphy imaging in an optical engine.
- Detailed investigation of the combustion stratification based on the high-speed OH* chemiluminescence imaging (Fig. 1).
- Study the effect of EGR and SOI on the flow characteristics and turbulence features of PPC combustion in the combustion chamber and inside the piston bowl based on the high-speed PIV method.

DISSERTATIONS

-

SCIENTIFIC PUBLICATIONS

1. Izadi Najafabadi, M., Somers, B., and Nuraini, A., "Validation of a Reduced Chemical Mechanism Coupled to CFD Model in a 2-Stroke HCCI Engine," SAE Technical Paper 2015-01-0392, 2015, doi:10.4271/2015-01-0392.

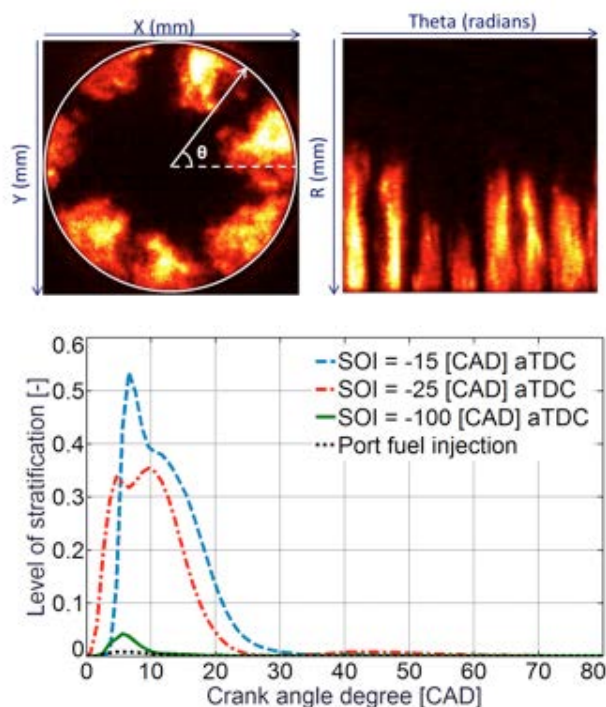

Time resolved Fourier-based stratification for different injection timings.

THE ROLE OF AROMATICS IN SOOT FORMATION

PROJECT AIM

The aim of the project is to study the breakdown and reappearance of aromatics in vaporized liquid fuel diffusion flames, using aliphatic fuels doped with aromatics. The focus lies on the development and application of (laser) optical detection techniques for intermediate species, found in the flame between the fuel pyrolysis zone and PAH formation zone, in order to gain a more detailed understanding of the found relation between aromatic fuel content and soot emission of combustion engines.

PROGRESS

The research started with a literature study; publications of previous users of the "inherited" co-flow burner setup have been studied, as well as papers from other institutes, related to the problem description. The experimental setup has been moved and taken apart first, to check for any inconsistencies with the setup description in the found literature. During this assessment, some parts have been cleaned, removed or replaced with new components. A laser-optical setup (Nd:YAG) has been built and first spectrally resolved laser-induced emission measurements have been performed. These measurements will be continued and an attempt will be made to identify in-flame intermediate species using Fourier transform infrared spectroscopy and Raman spectroscopy.

DISSERTATIONS

-

SCIENTIFIC PUBLICATIONS

-

PROJECTLEADERS

LPH de Goeij, NJ Dam

RESEARCHTHEME

Complex dynamics of fluids

PARTICIPANTS

R Doddema, NG Deen

COOPERATIONS

-

FUNDED

TU/e

University 100 %

FOM -

STW -

NWO Other -

Industry -

TNO -

GTI -

EU -

Scholarships -

START OF THE PROJECT

2015

INFORMATION

R Doddema

040 247 5995

r.doddema@tue.nl

www.tue.nl/combustion



Prof.dr.ir. D Smeulders



Prof.dr. HA Zondag



Prof.dr. H van Brummelen

Research in the field of Energy Technology at a Mechanical Engineering Department requires the combination of fundamental research and the study of engineering systems and devices. The fundamental research is in the field of Heat Transfer, and the engineering system focuses on small-scale Energy Systems with a strong emphasis on sustainability.

The approach is to combine advanced experimental, analytical and numerical techniques to investigate fundamental topics in heat transfer, and to design, construct and test real energy conversion systems. In this way, the research also contributes to the engineering and research training of the mechanical engineering students. The research is concentrated on three topics:

A. HEAT TRANSFER AND TRANSITIONAL FLOWS.

The research in this area is aimed at a better understanding of the fundamental characteristics of transitional flows in general. Flow cases that are studied are bypass transition along a flat plate (related to turbine blade cooling), laminar thermal transport in compact systems and boiling process control (for heat removal and thermal homogenisation in, for example, lithographic systems). Another research line concentrates on non-equilibrium phase transitions in gas-vapor mixtures.

B. MICRO-SCALE HEAT TRANSFER AND FLOW PHENOMENA

The aim of this research line is to achieve a better understanding of the heat and mass transfer processes at the small scales. The focus is on evaporative cooling of electronic components, on multi-scale analysis for compact heat storage materials and permeable geothermal reservoirs, and the dynamics of integrated fluid drivers in micro systems. On the smallest scales the physical processes are studied by coupling Molecular Dynamics analysis with a Direct Simulation Monte Carlo model.

C. HEAT TRANSFER ENGINEERING

The research activities in this area focus more on the system level rather than on the phenomenological level. Main research projects are fouling of heat exchangers used in waste- incinerators and biomass gasifiers, the design of a humidity harvesting device, and heat transfer models in the built environment. Another research line concentrates on biomass reactors for thermo-chemical applications.

More information about the research activities in these areas can be found on our website: www.energy.tue.nl

DEVELOPING A COMMERCIAL TEST SYSTEM TO DETERMINE THE MOST OPTIMAL TORREFACTION PARAMETERS

PROJECT AIM

This study aims to develop a small scale automatic testing system which determines the optimal torrefaction process parameters to achieve the best possible quality output (specifications set by the end user) while taking into consideration the overall energy balance of the torrefaction system to operate auto thermal. Secondly, the torrefied biomass samples produced by the testing system are used for pelletising and grinding tests to determine the optimal torrefaction settings to produce a durable pellet which requires a low grinding energy when pulverized. It is expected that large scale torrefaction systems are able to torrefy different biomass feedstocks because it is now known how the biomass behaves under different torrefaction conditions (gas mixture, temperature and residence time in the reactor).

PROGRESS

The prototype test system is finished, it can monitor the temperature development through the large biomass sample, can determine real-time the calorific value of the ablated gas originating from the biomass. By measuring the flow, the weight loss of the biomass sample is estimated. Below the results are shown of a beech wood sample with a diameter of 30mm and a height of 20mm.

DISSERTATIONS

-

SCIENTIFIC PUBLICATIONS

-

PROJECT LEADERS

DMJ Smeulders

RESEARCH THEME

Complex dynamics of fluids

PARTICIPANTS

ZC Bourgonje, HJ Veringa, W Loor, HPJ Vliegen JM Hullu

COOPERATIONS

Klinkenberg BV, Biolake

FUNDED

University	90 %
FOM	-
STW	-
NWO Other	-
Industry	10 %
TNO	-
GTI	-
EU	-
Scholarships	-

START OF THE PROJECT

2012

INFORMATION

ZC Bourgonje
040 247 3124
z.c.bourgonje@tue.nl

Torrefaction experiments at a reactor temperature of 300° were only the residence time of the biomass sample is varied. The vertical lines in the plot correspond the samples in the picture. In the upper graph the power generated by combusting the ablated gas from the wood is shown together with gas flow. In the lower graph on the left vertical axis is the temperatures displayed while on the right axis the weight loss and the shrinkage of the biomass sample is shown.

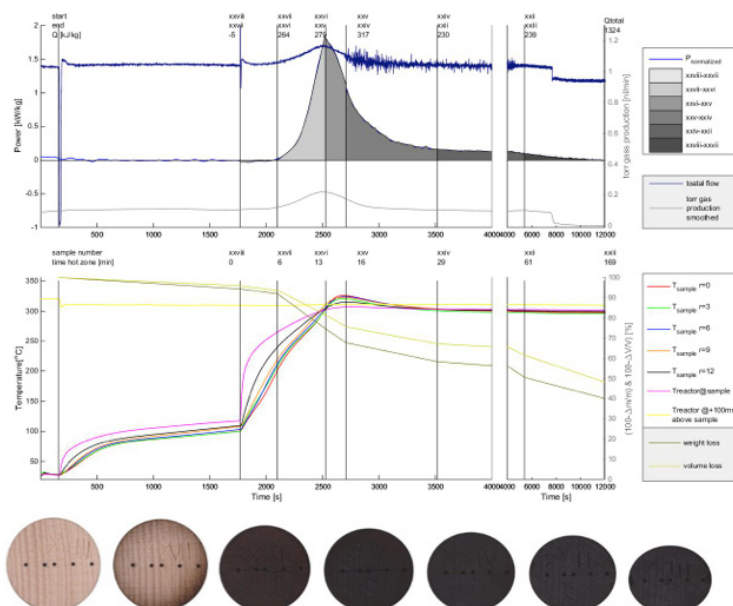

INTERFACIAL EFFECTS IN IONIZED POROUS MEDIA

PROJECT LEADERS

JM Huyghe, SM Hassanizadeh,
D Smeulders

RESEARCH THEME

Complex structures of fluids

PARTICIPANTS

K Malakpoor, S Musa, C Yu, J Ding,
T Sweijen

COOPERATIONS

Utrecht University

FUNDED

STW, Procter and Gamble, Dassault Systemes University	-
FOM	-
STW	80 %
NWO Other	-
Industry	20 %
TNO	-
GTI	-
EU	-
Scholarships	-

START OF THE PROJECT

2013

INFORMATION

JM Huyghe
j.m.r.huyghe@tue.nl
[https://www.tue.nl/en/university/
departments/mechanical-
engineering/the-department/staff/
detail/ep/e/d/ep-uid/19960315/](https://www.tue.nl/en/university/departments/mechanical-engineering/the-department/staff/detail/ep/e/d/ep-uid/19960315/)

PROJECT AIM

The performance of industrial products depends in many applications on the microstructure of porous materials that compose the product. Present models for prediction of the performance of materials smooth out the microstructure in order to accommodate a continuum approach used in the finite element codes. The present project aims at developing the theoretical, numerical and experimental techniques necessary to include the microstructure into 3D models of swelling porous materials.

PROGRESS

A 2D model of swelling and fracture has been developed. Experimental techniques measure the finite swelling.

DISSERTATIONS

-

SCIENTIFIC PUBLICATIONS

1. J.M. Huyghe, E. Nikoee, M. Hassanizadeh. Two sides of a coin: A critical review and mathematical and phenomenological study of what we call hydro-mechanical coupling. ECCOMAS Vith International Conference on Coupled Problems in Science and Engineering. San Servolo Island, Venice, Italy, 2015.
2. S. Musa, J.M. Huyghe. A model for colloidal transport driven by long-range interactions at interfaces. Oral presentation, Interpore 2015, Padua Italy.
3. J.M. Huyghe, E. Nikoee, M. Hassanizadeh. A thermodynamic approach to the coupled phenomena in unsaturated media. Interpore 2015, Padua, Italy.
4. J.M. Huyghe Finite swelling and fracture of biological tissues, Hyrogels and shales. Plenary lecture, ECCOMAS Vith International Conference on Coupled Problems in Science and Engineering. San Servolo Island, Venice, Italy, 2015.

CRYSTALLIZATION, NUCLEATION AND DROPLET GROWTH FOR THE COMBINED GAS TREATMENT AND LIQUEFACTION OF NATURAL GAS

PROJECT AIM

Liquefaction of natural gas involves several pre-treatment steps to remove contaminants from raw natural gas, such as: water, carbon dioxide, ethane, butane, nitrogen. These components are being removed to prevent their deposition at cryogenic conditions on equipment during actual liquefaction process, meet the international LNG sales and purchase agreements. In this In this research project we evaluate the feasibility of liquefaction of natural gas, with very limited gas treatment or heavy carbons removal, by investigating phase transitions (crystallization points, nucleation rates and Wilson points) for multi-component gas mixtures. The goal is to acquire the adequate description of nucleation phenomena, build the corresponding computational model.

PROGRESS

On one hand molecular dynamics simulations were carried out for single-component systems (Argon, Helium) to gain a close-up look at homogeneous nucleation process. This was studied by tracing and analyzing parameters such as: temperature of the system, maximum cluster size and onset of nucleation. On the other hand experiments were performed in an Expansion Cloud Chamber set-up for detection of liquid and solid formation in carbon dioxide and natural gas mixture. The chamber was filled up with gas mixture at given pressure. By means of a rapid electromagnetic valve, the gas was expanded into the vacuum tank giving rise to condensation and crystallization phenomena.

DISSERTATIONS

-

SCIENTIFIC PUBLICATIONS

-

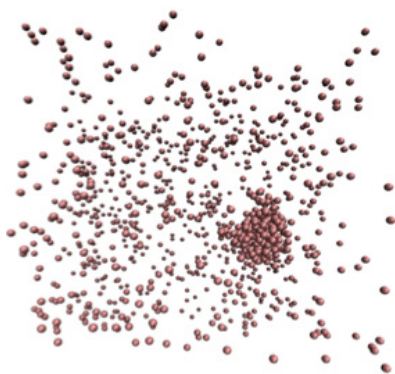

Snapshot of nucleation simulation in single-component Argon box system

PROJECTLEADERS

JAM Dam

RESEARCHTHEME

Complex structures of fluids

PARTICIPANTS

LR Dumitrescu, DMJ Smeulders,
JAM DAM

COOPERATIONS

TKI, Shell

FUNDED

Shell, TKI Gas
University 75 %
FOM -
STW -
NWO Other -
Industry 25 %
TNO -
GTI -
EU -
Scholarships -

START OF THE PROJECT

2013

INFORMATION

DMJ Smeulders
040 247 3167
d.m.j.smeulders@tue.nl.

HEAT STORAGE FOR SMART GRIDS - DEVELOPMENT OF DESIGN METHODS FOR OPTIMAL INTEGRATION AND CONTROL OF SHORT-AND LONG-TERM HEAT STORAGE IN INTELLIGENT ENERGY NETWORKS

PROJECT LEADERS

HA Zondag (TU/e), CCM Rindt (TU/e), J van Bael (VITO), J Diriken (VITO)

RESEARCH THEME

Mathematical and computational methods for fluid flow analysis

PARTICIPANTS

L Scapino

COOPERATIONS

VITO (Flemish Institute of Technological Research)

FUNDED

VITO (Flemish Institute of Technological Research)

University	-
FOM	-
STW	-
NWO Other	-
Industry	100 %
TNO	-
GTI	-
EU	-
Scholarships	-

START OF THE PROJECT

2015

INFORMATION

L Scapino
040 247 3172
l.scapino@tue.nl

PROJECT AIM

The aim of the project is to investigate and to develop guidelines for the optimal combination of short- and long-term thermal storage techniques, with strong emphasis on thermochemical storage, and their dimensioning to stabilize the energy grid for a given combination of thermal and electrical energy demand and supply techniques. Moreover, the requirements, boundary conditions, and scientific challenges for the integration of thermochemical heat storage in smart grids are also investigated.

PROGRESS

In the first part of the project, a state-of-the-art review about thermochemical materials and existing thermochemical heat storage prototypes has been carried out in the form of a scientific report. Then, size and materials cost of different thermochemical heat storage systems based on solid sorption using different thermochemical materials has been estimated for a common reference scenario. The results have been compared with systems based on liquid sorption to confront their performance in terms of energy and materials costs. The next step is to develop a techno-economic model to assess the benefit of thermochemical heat storage systems in an energy grid with distributed energy sources.

DISSERTATIONS

-

SCIENTIFIC PUBLICATIONS

-

DEVELOPMENT OF MICRO- AND MESO-SCALE MODELS FOR THERMO-CHEMICAL HEAT STORAGE MATERIALS

PROJECT AIM

For the purpose of the development of solid sorption materials, micro- and meso-scale models will be developed for the hydration and dehydration processes taking place in powdery samples. These processes are a combination of heat and vapor transport in the grains constituting the powdery sample and in the voids between the grains of the powdery sample. A complication in the modeling is that the solid-state kinetics in the hydration and dehydration processes is hard to be described satisfactorily. Besides, the macro- and micro- mechanical and transport properties will change during the reaction. Detailed characterization of interested materials has to be performed.

PROGRESS

A multiple grain model is developed to solve the hydrodynamics in the pores of multiple grains and the dehydration reaction inside the grains. The former developed grain model for the reaction kinetics is used to describe the nucleation and nuclei growth processes of the reaction. The present multiple grain model then has a detailed description of the fluid flow and water vapor distribution between the particles and the nucleation and nuclei growth processes inside the particles. Direct numerical simulations of TGA-experiments under various conditions are performed and the numerical results are compared to the experimental results up to a satisfaction level (see Figure 1). Such simulations provide direct insight into the physics of mass and heat transport processes coupled with detailed reaction kinetics at grain scale. The developed CFD model can be a promising tool to calculate the overall kinetics for dehydration reactions under realistic heat storage conditions.

DISSERTATIONS

-

SCIENTIFIC PUBLICATIONS

1. Lan, Shuiquan, Zondag, Herbert, van Steenhoven, Anton & Rindt, Camilo (2015). An experimentally validated numerical model of interface advance of the lithium sulfate monohydrate dehydration reaction. *Journal of Thermal Analysis and Calorimetry*.
2. Lan, Shuiquan, Zondag, Herbert, van Steenhoven, Anton & Rindt, Camilo (2015). Kinetic study of the dehydration reaction of lithium sulfate monohydrate crystals using microscopy and modeling. *Thermochimica Acta*, 621.

PROJECTLEADERS

CCM Rindt, HA Zondag,
AA van Steenhoven

RESEARCHTHEME

Complex dynamics of fluids

PARTICIPANTS

S Lan

COOPERATIONS

ECN (Energy research Center of the Netherlands)

FUNDED

ADEM Innovation Lab Program

University	-
FOM	-
STW	-
NWO Other	-
Industry	100 %
TNO	-
GTI	-
EU	-
Scholarships	-

START OF THE PROJECT

2011

INFORMATION

CCM Rindt
040 247 2978
C.C.M.Rindt@tue.nl
www.energy.tue.nl

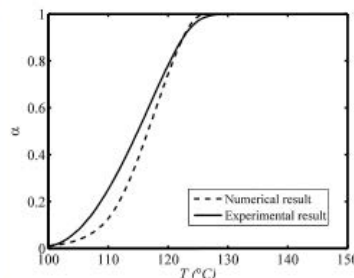
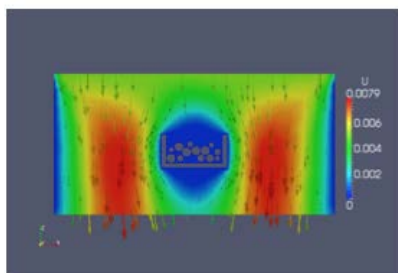

Typical profile of velocity distribution from TGA simulation (left) and fractional conversion of the dehydration reaction of the $\text{Li}_2\text{SO}_4 \cdot \text{H}_2\text{O}$ powdery samples: Numerical result in the dashed line and experimental result in the solid line (right).

SIMULATION OF DROPLET FORMATION AND ABSORPTION BASED ON DIFFUSE INTERFACE MODEL

PROJECT LEADERS

EH van Brummelen

RESEARCH THEME

Mathematical and computational methods for fluid flow analysis

PARTICIPANTS

M Shokrpour Roudbari, G Simsek,
GJ van Zwieten, EH van Brummelen,
HMA Wijshoff

COOPERATIONS

-

FUNDED

NanoNextNL (FES)	
University	25 %
FOM	-
STW	-
NWO Other	-
Industry	75 %
TNO	-
GTI	-
EU	-
Scholarships	-

START OF THE PROJECT

2011

INFORMATION

EH van Brummelen
040 247 5470
e.h.v.brummelen@tue.nl
www.tue.nl/vanbrummelen

PROJECT AIM

This project aims at the development of a computational platform to simulate the droplet formation and the absorption, where the latter itself is accompanied by two other phenomena; evaporation and wetting. On account of the multiscale/multicomponent nature of both problems, it is necessary to analyse the underlying physical phenomena in an accurate mathematical description. On top of that the accuracy of the numerical simulations should be controlled using distinctive error analysis techniques.

PROGRESS

Subproject #1 a multi-scale diffuse interface model was developed for two-phase flow problems in porous media. The results are submitted in one paper.

Subproject #2 primary numerical results have been obtained for the Navier-Stokes-Korteweg-Energy equations.

Subproject #3 the numerical results for the Navier-Stokes-Cahn-Hilliard with a wetting boundary condition were extended to the complex-fluid-solid interaction in elasto-capillary problem. This work is published as a chapter book.

Subproject #4 a baseline model for the NSCH equations for non-matched densities with gravity has been derived and implemented. A naïve time-discretization procedure is designed for the model and a paper with the results is in preparation.

DISSERTATIONS

-

SCIENTIFIC PUBLICATIONS

1. G. SIMSEK, X. WU, K.G. VAN DER ZEE and E.H. VAN BRUMMELEN, 2015. Duality-based two-level error estimation for time-dependent PDEs: Application to linear and nonlinear parabolic equations Computer Methods in Applied Mechanics and Engineering. 288, 83-109.

ADAPTIVE MOMENT-CLOSURE APPROXIMATIONS OF THE BOLTZMANN EQUATION

PROJECT AIM

The aim of this project is to create a paradigm for adaptive hierarchical moment-closure approximations of the Boltzmann equation.

PROGRESS

A discontinuous Galerkin finite element scheme for the derived moment equations was developed. The scheme exploited the observation that the moment equations are a Galerkin approximation of the renormalized Boltzmann equation. This led to a newly constructed numerical flux that is consistent and conservative in the usual sense. Moreover it was shown that the new numerical flux is entropy stable. An article on the formulation has been submitted. Extension to multi-D and implementation of an adaptive procedure are currently in progress.

DISSERTATIONS

-

SCIENTIFIC PUBLICATIONS

-

PROJECTLEADERS

EH van Brummelen

RESEARCHTHEME

Mathematical and computational methods for fluid flow analysis

PARTICIPANTS

M Abdel Malik, EH van Brummelen

COOPERATIONS

M Torrilhon (RWTH Aachen)

FUNDED

TU/e	
University	100 %
FOM	-
STW	-
NWO Other	-
Industry	-
TNO	-
GTI	-
EU	-
Scholarships	-

START OF THE PROJECT

2011

INFORMATION

EH van Brummelen

040 247 5470

e.h.v.brummelen@tue.nl

www.tue.nl/vanbrummelen

ISOGEOMETRIC FINITE CELL METHODS FOR FLUID-STRUCTURE INTERACTIONS OF THIN EMBEDDED STRUCTURES

PROJECT LEADERS

EH van Brummelen

RESEARCH THEME

Mathematical and computational methods for fluid flow analysis

PARTICIPANTS

F de Prenter, CV Verhoosel,
EH van Brummelen

COOPERATIONS

-

FUNDED

NWO

University -

FOM -

STW -

NWO Other 100 %

Industry -

TNO -

GTI -

EU -

Scholarships -

START OF THE PROJECT

2015

INFORMATION

F de Prenter

0615162599

f.d.prenter@tue.nl NanoNextNL_

Mahnaz_Gorkem.doc

<https://www.tue.nl/en/university/>

departments/mechanical-

engineering/the-department/staff/

detail/ep/e/d/ep-uid/20098756/

PROJECT AIM

We aim to develop an immersed/fictitious domain method to compute the fully coupled evolution of Fluid-Structure Interaction systems. A challenging aspect in this project will be the derivation of convective terms on time-dependent domains. Matrix-conditioning, stability and accuracy of the method will be assessed. We aim to develop the method such that it enables the use of compatible (divergence-free) function spaces.

PROGRESS

The conditioning problems in immersed/fictitious domain methods have been analyzed and the main cause of ill-conditioning has been located. With this knowledge, an effective preconditioner, which we named SIPIC, has been created, that results in a condition number that does not depend on the way elements are cut in the immersed approach. Experiments show that the condition numbers of preconditioned (immersed) systems are similar to those of boundary fitted systems. Performance of iterative solvers has drastically improved in all numerical experiments. A manuscript has been submitted to Computer Methods in Applied Mechanics and Engineering.

DISSERTATIONS

-

SCIENTIFIC PUBLICATIONS

-

INTEGRATED MICRO-FLUIDIC COOLING IN LAMINATED FLEXIBLE MICRO-SYSTEMS

PROJECT AIM

Electronic devices will in the future be made more and more also as flexible system-in-foil (SIF) which can contain ultra-thin (15 – 50 micron) flexible embedded silicon chips. A challenge is given by the low thermal conductivity of the very thin polymeric package aggravating the heat management problem. The aim of this project to develop an integrated micro-fluidic cooling system in a laminated flexible micro-system.

PROGRESS

A new modelling approach was followed: the system is modelled by a non-linear mass-spring-damper system and was implemented in SIMULINK. Main advantages of such approach that the results are easier to interpret than in a CFD model, since it can be related to the non-linear springs and dampers. Therefore, the effects of asymmetry in filling and in material properties and the stability issues can be better addressed. Evaporation and condensation are included in de model. The model is compared with both numerical and experimental results from literature. Simulations show that including asymmetry into the system results in a good agreement with experimental results. Also, four different modes of motion are observed: Oscillatory motion, translation, combined oscillatory-translation motion and no motion. Motion composition of a PHP as a function of heat input is analyzed.

DISSERTATIONS

-

SCIENTIFIC PUBLICATIONS

- Gürsel, Gökalp, Frijns, Arjan, Homburg, Erik & van Steenhoven, Anton (2015). A mass-spring-damper model of a pulsating heat pipe with a non-uniform and asymmetric filling. Applied Thermal Engineering, 91(1), 80-90.

PROJECT LEADERS

AJH Frijns, AA van Steenhoven

RESEARCH THEME

Complex dynamics of fluids

PARTICIPANTS

G Gürsel, D Florea, E Homburg, JMJ den Toonder

COOPERATIONS

Philips, Holst Centre

FUNDED

STW	
University	-
FOM	-
STW	100 %
NWO Other	-
Industry	-
TNO	-
GTI	-
EU	-
Scholarships	-

START OF THE PROJECT

2011

INFORMATION

AJH Frijns

040 247 4825

a.j.h.frijns@tue.nl

www.energy.tue.nl

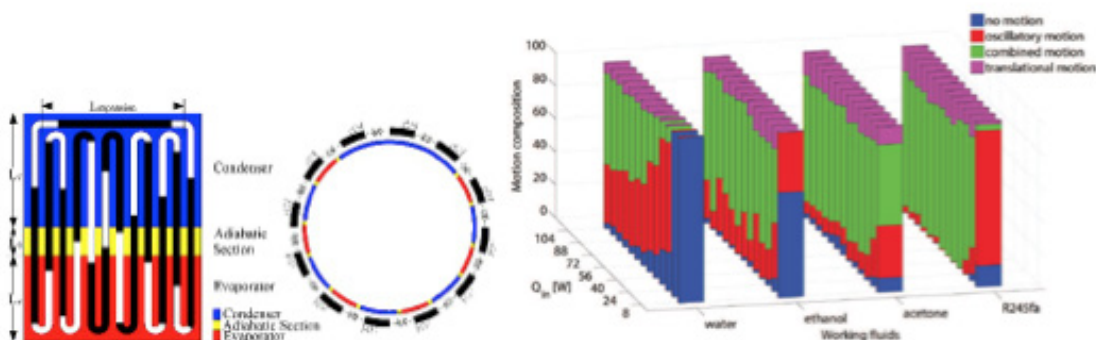

MOLECULAR MODELING OF SUGAR ALCOHOLS AS SEASONAL HEAT STORAGE MATERIALS

PROJECT LEADERS

DMJ Smeulders, SV Nedeá, CCM Rindt

RESEARCH THEME

Mathematical and computational methods for fluid flow analysis

PARTICIPANTS

H Zhang

COOPERATIONS

-

FUNDED

EU-FP7

University -

FOM -

STW -

NWO Other -

Industry -

TNO -

GTI -

EU 100 %

Scholarships -

START OF THE PROJECT

2012

INFORMATION

H Zhang

040 247 3172

h.zhang@tue.nl

PROJECT AIM

Sugar alcohols (SA) and their eutectic mixtures are promising seasonal heat storage medium. These materials are environmentally friendly, low cost, and high in storage capacity. Because of the large subcooling effect, SA can remain in liquid state thus enabling low loss storage. Nevertheless, the low nucleation and crystallization kinetics and the low heat conduction rate results in poorly controlled discharge power and introduces difficulties in large scale industrial applications. Using molecular modeling methods, we can tackle the details during the nucleation process and nanoscale heat transfer mechanism, depict the free energy landscape, and propose possible solutions to increase the nucleation and heat transfer kinetics.

PROGRESS

During this research period, SA heat conductivity enhancement is studied using molecular dynamics simulations. Graphene and carbon nanotubes are proposed to function as the enhancement additive. The effective heat conductivity can be obtained using effective medium approaches, given the conductivity of the carbon structures and the matrix SAs, and a contact resistance term of SA-carbon interface. During the calculation of the contact resistance, the heat transfer across single layered carbon structures is found to be dependent on the simulation setup. The heat transfer is much faster when the carbon layer is used as a transfer medium compared to when the carbon layer is used as the heat source. The heat transfer rate is also dependent on the nanotube's size. In general, the heat transfer is more sluggish for smaller sized tubes. However this trend is not monotonic.

DISSERTATIONS

-

SCIENTIFIC PUBLICATIONS

- Zhang, H., Nedeá, S.V., Rindt, C.C.M., Smeulders, D.M.J. (2015). Thermal Contact Resistance in Carbon Nanotube Enhanced Heat Storage Materials. Conference Paper: Proceedings of the 2nd European Conference on Non-equilibrium Gas Flow (NEGF2015), December 9-11, 2015, Eindhoven, the Netherlands.
- Zhang, H., Nedeá, S.V., Rindt, C.C.M. (2015). Review and in Silico Characterization of Sugar Alcohols as Season Heat Storage Materials. Conference Paper: The 13th International Conference on Energy Storage-Greenstock 2015, At Beijing, China.

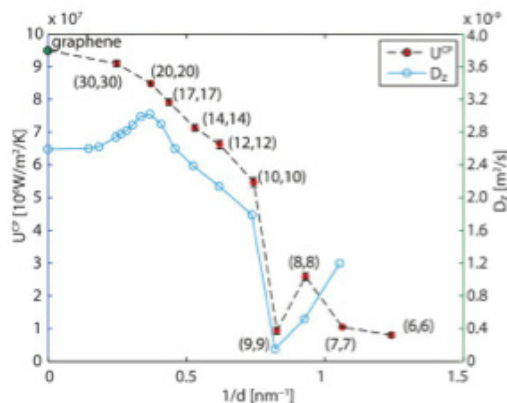

Heat transfer coefficient across the carbon nanotubes and axial diffusion coefficient of confined water versus reciprocal diameter. The results of graphene is marked on 1/d=0.

NUMERICAL MODELLING OF HYDRAULIC FRACTURING

PROJECT AIM

The aim of this project is to develop a numerical model to predict the propagating fracture patterns that grow during hydraulic fracturing. Such a numerical model may be useful to identify key parameters in the hydraulic fracturing process and may be helpful to optimize the fracture process.

PROGRESS

We developed the Enhanced Local Pressure (ELP) model in order to accurately predict the pressure gradient due to fluid leakage near a propagating hydraulic fracture surface. In this model, which can be considered as an extension of the partition of unity based representations, the pressure in the fracture is described by an additional set of degrees of freedom. The pressure gradient is reconstructed analytically, based on Terzaghi's consolidation solution. With this numerical formulation we also ensure that all externally applied fluid flow goes exclusively in the fracture and avoid the necessity to use a fine mesh near the fracture to capture the pressure gradient.

DISSERTATIONS

-

SCIENTIFIC PUBLICATIONS

1. Remij, E.W., Remmers, J.J.C., Huyghe, J.M.R.J. & Smeulders, D.M.J. (2015). The enhanced local pressure model for the accurate analysis of fluid pressure driven fracture in porous materials. *Computer Methods in Applied Mechanics and Engineering*, accepted or in press.
2. Remij, E.W., Remmers, J.J.C., Pizzocolo, F., Smeulders, D.M.J. & Huyghe, J.M.R.J. (2014). A partition of unity-based model for crack nucleation and propagation in porous media, including orthotropic materials. *Transport in Porous Media*, 1-18.
3. Remij, E.W., Remmers, J.J.C., Huyghe, J.M.R.J. & Smeulders, D.M.J. (2014). Numerical modelling of hydraulic fracturing. In F. Oka, A. Murakami, R. Uzuoka & S. Kimoto (Eds.), *Conference Paper : Proceedings of the 14th international conference of international association for computer methods and recent advances in geomechanics*, Kyoto, Japan, 22-25 September 2014, CRC Press.

PROJECTLEADERS

JJC Remmers, JM Huyghe,
DMJ Smeulders

RESEARCHTHEME

Mathematical and computational
methods for fluid flow analysis

PARTICIPANTS

EW Remij

COOPERATIONS

Baker Hughes, EBN, GDF Suez,
TKI Gas, Total, Tu Delft, University
Utrecht, Wintershall

FUNDED

Baker Hughes, EBN, GDF Suez,
TKI Gas, Total, Wintershall
University -
FOM -
STW -
NWO Other -
Industry 100 %
TNO -
GTI -
EU -
Scholarships -

START OF THE PROJECT

2013

INFORMATION

E Remij
040 247 3124
e.w.remij@tue.nl
www.2f2s.org

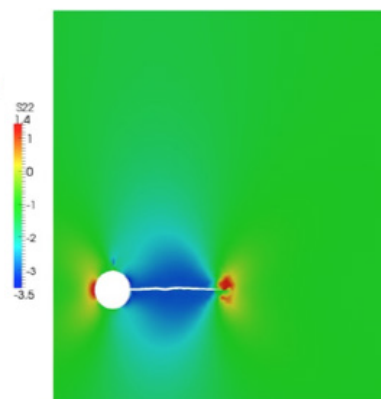
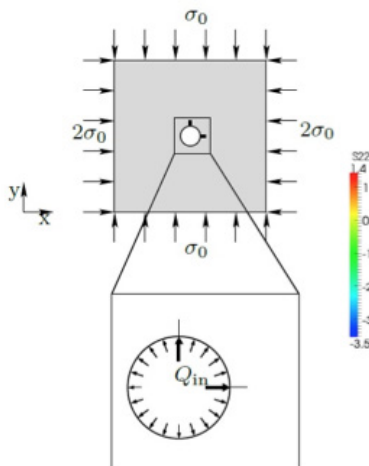

-hydraulic fracture growing in the direction of
the highest confining stress

THERMOCHEMICAL SEASONAL HEAT STORAGE FOR BUILT ENVIRONMENT

PROJECT LEADERS

HA Zondag, CCM RIndt

RESEARCH THEME

Complex dynamics of fluids

PARTICIPANTS

M Gaeini

COOPERATIONS

ECN

FUNDED

University, Province Noord Brabant

University 30 %

FOM -

STW -

NWO Other -

Industry -

TNO -

GTI -

EU 70 %

Scholarships -

START OF THE PROJECT

2013

INFORMATION

M Gaeini

040 247 2768

M.Gaeini@tue.nl

PROJECT AIM

Heat is stored by an endothermic reaction in thermochemical material in summer, and in winter the released energy from an exothermic reaction is used to provide hot tap water and space heating. The goal of the project is to develop and optimize a prototype for thermochemical heat storage system at the scale of 0.25 m³. The problem can be described on three levels; various materials should be examined to find the most suitable one for seasonal heat storage; the reactor as the main part of the setup should be technically optimized; all the other parts of the system, such as humidifier and heat exchangers, should be designed and integrated all together as a system.

PROGRESS

A setup is developed and improved to perform hydration and dehydration experiments, in order to demonstrate the ability of the thermochemical system in producing hot tap water. The heat produced in the reactor is exchanged through an internal air-to-water heat exchanger to warm up water in a water vessel and the residuum of the heat is used to preheat the reactor inflow in an air-to-air heat exchanger. The thermal performance of the system can be investigated by the thermocouples located in all parts of the system; i.e. reactor, water vessel, heat exchanger and piping. Previously, the performance of the system is investigated; and in the recent work, a new reactor based on the segmentation concept is designed and attached to the system to examine its performance and evaluate the advantages and disadvantages of the segmented reactor. This reactor consists of two segments which can be separately, or together in series or in parallel.

DISSERTATIONS

SCIENTIFIC PUBLICATIONS

1. Gaeini, M., Zondag, H.A., Rindt, C.C.M. (2015). Improvement in Performance of a Thermochemical Heat Storage System by Implementing an Internal Heat Recovery System. Conference Paper: Proceedings of the 13th International Conference on Energy Storage, Greenstock, May 19-21, 2015, Beijing, China.

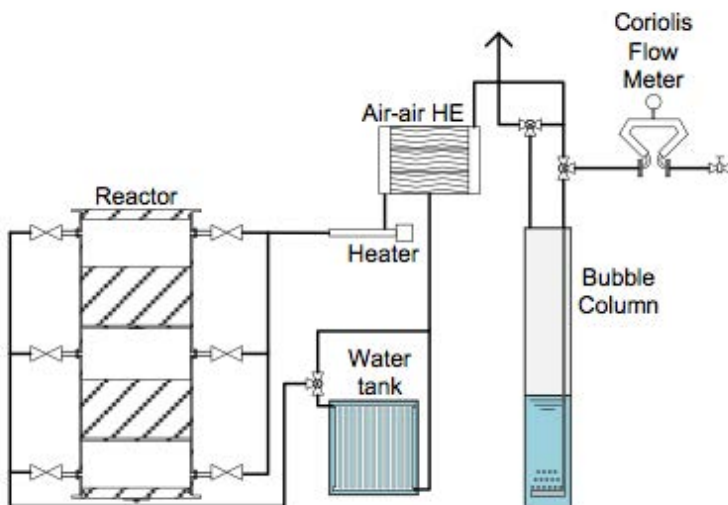

MULTISCALE SIMULATIONS FOR THERMO CHEMICAL HEAT STORAGE USING NEW COMPOSITE MATERIALS

PROJECT AIM

The promising concept for seasonal solar heat storage in the built environment is based on the reversible sorption process of water vapor into the crystalline structure of salt hydrates (MgSO₄, MgCl₂, LiSO₄, etc). Their main advantages are a high energy density, a reaction temperature in the proper range for domestic applications and their low price. A detailed study on molecular level (Molecular dynamics simulations) of the of salt hydrates is necessary in order to gain insight into the dynamics of the hydration/ dehydration processes and their limiting factors in these systems.

PROGRESS

One of the key aspects in designing the solar based heat storage system is selection of TCM materials. The major challenge in selection of these salt hydrates is their storage capacity and kinetics. MgCl₂.6H₂O is one of the most promising materials for thermal heat storage. It has very high energy storage density (2-3 GJ/m³) and is readily available. MgCl₂.nH₂O can thermally decompose either as dehydration reaction,

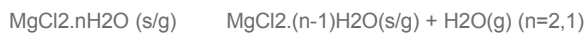

or hydrolysis reaction



Mass transport of water through the salt hydrate is an important process for storage cycle. The cracks, defects, over and under hydration in salt hydrates affects their storage capacity. We have performed MD simulation in MgCl₂.nH₂O to understand the effect of these factors on water diffusion through the salt hydrates. We have also obtained the HCl formation temperature from MD simulations.

DISSERTATIONS

-

SCIENTIFIC PUBLICATIONS

1. Pathak, A.; Nedeá, S.; Rindt, C.; Smeulders, D.; Zondag, H. Diffusive transport of water in Magnesium chloride hydrates. Proceedings NEGF 2015 conference, Eindhoven. 2015.

PROJECTLEADERS

SV Gaastra-Nedeá, HA Zondag,
CCM Rindt, DMJ Smeulders

RESEARCHTHEME

Mathematical and computational
methods for fluid flow analysis

PARTICIPANTS

A Deep Pathak

COOPERATIONS

ECN, FOM

FUNDED

FOM	
University	-
FOM	100 %
STW	-
NWO Other	-
Industry	-
TNO	-
GTI	-
EU	-
Scholarships	-

START OF THE PROJECT

2013

INFORMATION

A Deep Pathak
040 247 3172
a.d.pathak@tue.nl

BEYOND THE THERMAL COMFORT LIMITS: HEAT TRANSFER IN THE HUMAN BODY AND THERMAL COMFORT

PROJECT LEADERS

AJH Frijns

RESEARCH THEME

Mathematical and computational methods for fluid flow analysis

PARTICIPANTS

S Veselá, BRM Kingma,
H Pallubinsky, M te Culve,
L Schellen, L Schlangen,
WD van Marken Lichtenbelt,
AA van Steenhoven, DMJ Smeulders

COOPERATIONS

UM, MUMC+, Philips

FUNDED

RVO, STW, TU/e	
University	80 %
FOM	-
STW	-
NWO Other	20 %
Industry	-
TNO	-
GTI	-
EU	-
Scholarships	-

START OF THE PROJECT

1999

INFORMATION

A Frijns
040 247 4825
a.j.h.frijns@tue.nl
www.energy.tue.nl

PROJECT AIM

The goal of this project is to develop dynamic and human specific thermo-physiological model to predict the heat transfer and temperature distribution in the human body. The model will be used for the prediction of thermal comfort in the built environment.

PROGRESS

Recent research on local heating and cooling design show improvements in thermal comfort and energy consumption of office buildings. The impact of these measures on the occupants' local thermal sensation (LTS) the most important factors in the thermal modelling concept are studied and analysed using our thermophysiological model ThermoSEM: 1) the effects of the accuracy of the input data for local clothing properties and local muscular metabolic heat distribution, 2) the deviations between computed and measured local skin temperatures, and 3) neurophysiological and dynamic aspects that are missing in present LTS models. To fill this gaps, measurements are done on determining local clothing resistances and local metabolic rates, a re-evaluation of local heat balances in the thermophysiological models is done and the influences of blood pressure effects and neurophysiology will be incorporated in the ThermoSEM model.

DISSERTATIONS

-

SCIENTIFIC PUBLICATIONS

1. Kulve, te, M., Schellen, Lisje, Frijns, Arjan, Schlangen, L.J.M. & van Marken Lichtenbelt, W. (2015). The influence of LED lighting on thermal comfort, health and energy. In M. te Kulve & M. Loomans (Eds.), Healthy Buildings Europe 2015, 18-20 May 2015, Eindhoven, The Netherlands.
2. Veselá, Stephanie, Kingma, Boris & Frijns, Arjan (2015). Taking thermal regulation models from the lab to the world : are current views ready for the challenge?. In M. te Kulve & M. Loomans (Eds.), Healthy Buildings Europe 2015, 18-20 May 2015, Eindhoven, The Netherlands.

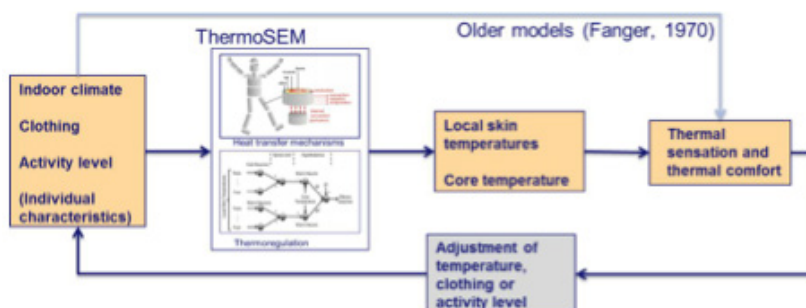



MICROSYSTEMS



Prof.dr.ir. JMJ den Toonder

The Microsystems group develops microsystems design approaches and out-of-cleanroom micro-manufacturing technologies that are rapid and flexible. these are applied to realize active mechanical control in micro-fluidics, to make and study meso-structured and soft materials, to create and study cells and organs on chips, and to develop advanced microsystems applications in collaboration with industrial partners. the group has a new micro-fabrication lab in development, and access to the Nanolab@TU/e cleanroom.

The Microsystems group is part of

MaTe, the Materials Technology Institute

ICMS, the Institute for Complex Molecular Systems

J.M.Burgerscentrum

EM, Graduate School on Engineering Mechanics

Human Organ and Disease Model Technologies

CANCER METASTASIS ON A CHIP

PROJECT AIM

The general goal of the project is to engineer tumor micro-environment in a controlled microfluidic system. In this work, our aim is to study the effect of extracellular matrix (ECM) stiffness on the invasive properties of the tumor cells. In order to realize a proper model for tumor, we are going to recreate the tumor micro-environment (including cancer cells, ECM and other cell types) inside a microfluidic chip. Then the invasion of the cancer cells into the blood stream will be investigated.

PROGRESS

In 2015, we have fabricated electrospun nano and micro fibers as the ECM to study 3D cancer cell migration. We have developed a novel method to integrate mats of the fibrous scaffold inside a microfluidic chip. Furthermore, we have designed a perfusion system to automatically refresh the media inside the chip and also run chemotaxis assays. After the biological experiment, the electrospun scaffold can be isolated from the microfluidic device for further analyses.

DISSERTATIONS

-

SCIENTIFIC PUBLICATIONS

1. Eslami Amirabadi et al., "Integration of electro-spun scaffolds inside microfluidic chips: Towards 3D migration assays on a chip", Poster presentation, NanoBioTech Montreaux, Switzerland; Nov. 2015.

PROJECT LEADERS

JMJ den Toonder, R Lutgje

RESEARCH THEME

Complex structures of fluids

PARTICIPANTS

H Eslami Amirabadi

COOPERATIONS

-

FUNDED

STW	
University	-
FOM	-
STW	100 %
NWO Other	-
Industry	-
TNO	-
GTI	-
EU	-
Scholarships	-

START OF THE PROJECT

2013

INFORMATION

H Eslami Amirabadi,
06 48536093
h.eslami.amirabadi@tue.nl
[www.tue.nl/en/university/
departments/mechanical-
engineering/the-department/staff/
detail/ep/e/d/ep-uid/20118704/](http://www.tue.nl/en/university/departments/mechanical-engineering/the-department/staff/detail/ep/e/d/ep-uid/20118704/)

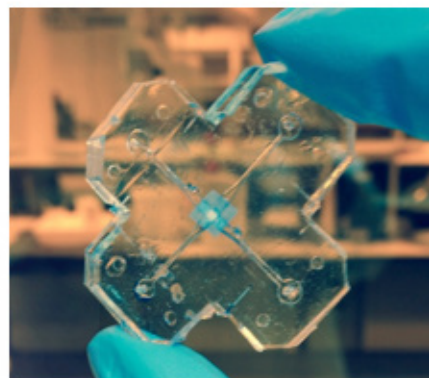
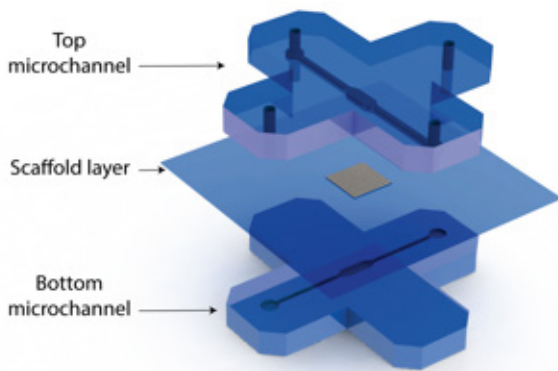

NEURONAL TISSUE ENGINEERING FOR BRAIN-ON-A-CHIP TECHNOLOGY

PROJECT LEADERS

R Luttge, JMJ den Toonder

RESEARCH THEME

Complex structures of fluids

PARTICIPANTS

A Bastiaens

COOPERATIONS

UT

FUNDED

TU/e

University 100 %

FOM -

STW -

NWO Other -

Industry -

TNO -

GTI -

EU -

Scholarships -

START OF THE PROJECT

2014

INFORMATION

A Bastiaens

040 247 4905

A.J.Bastiaens@tue.nl

www.tue.nl/universiteit/faculteiten/

faculteit-werktuigbouwkunde/

onderzoek/research-groups/

microsystems/

PROJECT AIM

The project aims to create an *in-vitro* 3D neuronal tissue model within a brain-on-a-chip platform, mimicking the function of the human brain. On this platform, neuronal connectivity and the associated (electrical and biological) functionality can be studied. Eventually this can be developed into a model for studying brain diseases such as epilepsy.

PROGRESS

In the previous year, we have focused on growing 3D cultures of differentiated neuroblastomas in different gel microenvironments (i.e. Matrigel, collagen-I, Puramatrix). From the results, cells in Matrigel were selected as the standard for future experiments. A revised microbioreactor (Figure a,b) was designed for the integration with a brain-on-a-chip platform. This microbioreactor is now used to optimize cell seeding density. Previous experiments indicated large variation between cell cultures in terms of cell distribution and neurite outgrowths (Figure c). A microfluidic droplet generator was designed to encapsulate single cells in small Matrigel droplets that thereafter gel into Matrigel beads. By stacking these beads we could introduce standardized, homogeneous cell distribution within 3D, neuronal cell cultures (Figure d,e). This approach is currently being optimized.

DISSERTATIONS

-

SCIENTIFIC PUBLICATIONS

1. J.P. Frimat, S. Xie, A.J. Bastiaens, B. Schurink, F. Wolbers, J.M.J. den Toonder, R. Luttge. Advances in 3D neuronal cell culture. *J. Vac. Sci. Technol.*, (2015) 33, 06F902.
2. R. Luttge, A.J. Bastiaens, J.J.F. Sleeboom. 3D Spatially organized cultured (neuronal) tissue by means of stacking beads comprising hydrogel encapsulated cells, Provisional patent, 7 Dec 2015, Appl. No.62/263807.

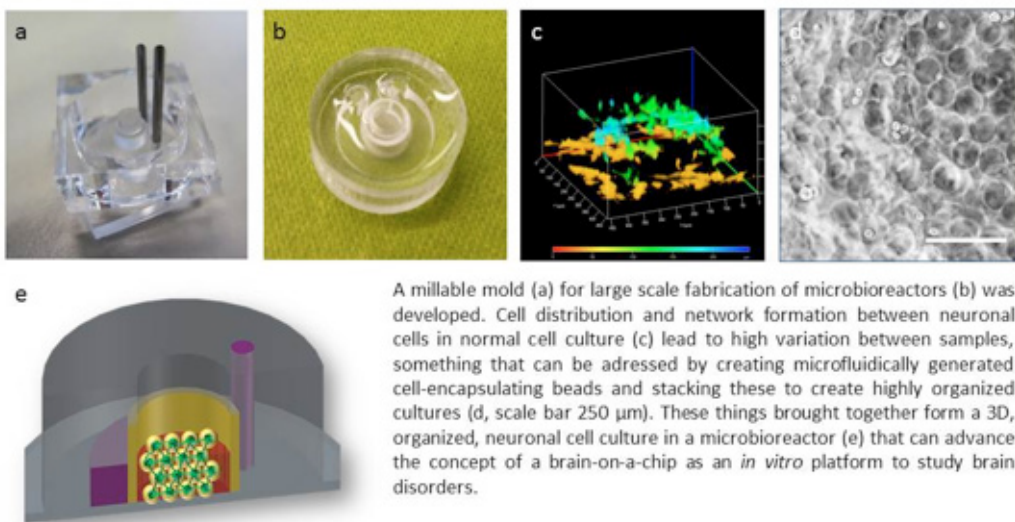

ARTIFICIAL CILIA FOR ANTI-FOULING SURFACES

PROJECT AIM

The aim of this project is to design and create magnetically actuated artificial cilia, and to integrate these onto surfaces in a microfluidic testing device to characterize the antifouling behavior of the ciliated surface. We will study the possibility to repel (micro-) particles, and to block the formation of biofilms, focusing on marine anti-fouling.

PROGRESS

Based on the experiments done and the roll-pulling device designed by Ye Wang, we have made masters with smaller diameters for pillars-making, that is 150 μm , 125 μm , 100 μm , 75 μm , 50 μm , so that we can make PDMS films featured with pillars with diameters 150 μm , 125 μm , 100 μm , 75 μm and 50 μm . After making pillars, we fix them onto the roll to fabricate cilia. Before making cilia, we use an instrument to make precursor. We have successfully made cilia with length larger than 200 μm . Our next step is to integrate cilia into microfluidic devices and actuate them using magnet setup designed by colleagues worked and working in our group to see the flow manipulation capability and micro-nano-particle propelling and catching capacity.

DISSERTATIONS

-

SCIENTIFIC PUBLICATIONS

-

PROJECTLEADERS

JMJ den Toonder

RESEARCHTHEME

Complex structures of fluids

PARTICIPANTS

S Zhang

COOPERATIONS

-

FUNDED

CSC

University -

FOM -

STW -

NWO Other -

Industry 100 %

TNO -

GTI -

EU -

Scholarships -

START OF THE PROJECT

2015

INFORMATION

S Zhang

040 247 5706

S.Zhang1@tue.nl

<http://www.tue.nl/universiteit/>

faculteiten/faculteit-

werktuigbouwkunde/onderzoek/

research-groups/microsystems/

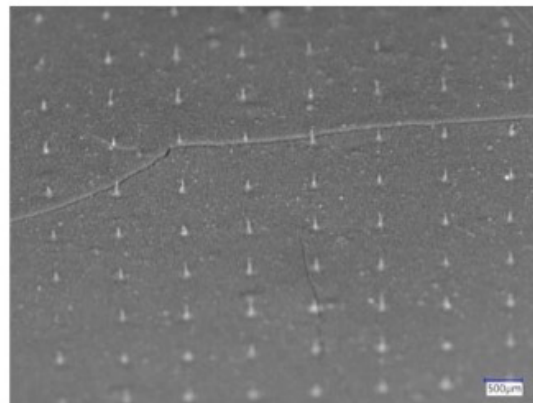
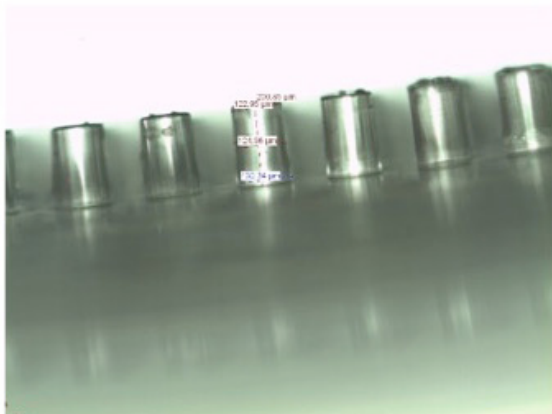

INTEGRATED MICRO-FLUIDIC COOLING IN LAMINATED FLEXIBLE MICRO-SYSTEMS

PROJECT LEADERS

JMJ den Toonder, FGH Homburg,
AJ Frijns

RESEARCH THEME

Complex dynamics of fluids

PARTICIPANTS

D Florea

COOPERATIONS

-

FUNDED

STW

University -

FOM -

STW 100 %

NWO Other -

Industry -

TNO -

GTI -

EU -

Scholarships -

START OF THE PROJECT

2014

INFORMATION

D Florea

040 247 2186

d.florea@tue.nl

www.tue.nl/universiteit/faculiteiten/

faculteit-werktuigbouwkunde/

onderzoek/research-groups/

microsystems/

PROJECT AIM

Due to the combination of the continued miniaturization of microelectronic components on the one hand, and the trend towards flexible electronics (and therefore the use of lower thermal conductivity materials), heat generation in flexible electronics becomes a serious challenge. The aim of this project is to realize and test a pulsating heat pipe that can be used in flexible electronics for cooling of critical components.

PROGRESS

A self-sustained cooling device based on a Pulsating Heat Pipe (PHP) was introduced in order to simplify the cooling process and furthermore to transfer more heat. My project was to design and test new prototypes in which microfluidic channels are integrated inside devices and they can be used to transfer the heat from the hot side (evaporator) to the cold side (condenser). In the last 12 months I have proposed a paradigm shift in the design of Pulsating Heat Pipes which I modelled and validated using simulations which now will be used as a framework by both research groups and industry.

DISSERTATIONS

-

SCIENTIFIC PUBLICATIONS

-

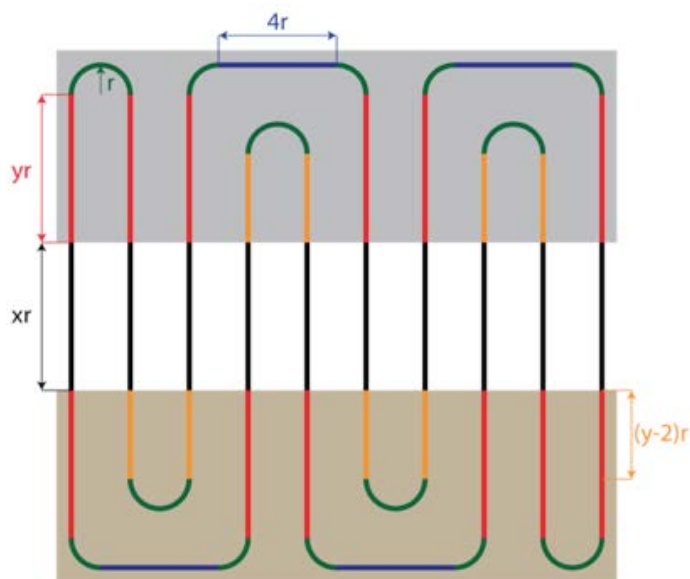

MESOTAS: CHATTING WITH NEURONS

PROJECT AIM

Our aim is to combine microfluidics with tissue engineering to create a 'living' brain, generating realistic neural circuitry on chip, which can be used to standardize experimental neuronal cell culture. To this end an on-chip microbio reactor is fabricated to reproduce the natural 3D neuronal network of the brain in an easy to use in vitro setting. Nanotools are designed to guide neurite outgrowth and biomechanically stimulate this neuronal network. To study brain physiology, these two research fields are combined to biochemically and biomechanically stimulate the neuronal network. In conclusion, our platform can serve as a model to study the brain and its diseases in vitro.

PROGRESS

Highly uniform sieving structures (made by corner lithography and silicon wet etching) for single neuron arraying at the interface between electrodes and 3D matrix inside our bioreactor has been developed (A). We have used these structures for the hydrodynamic capturing of differentiated SH-SY5Y neuron cell (B), suitable for integration of electrodes for electrophysiological measurements of neuronal networks. We show that trapping single neurons is successful (up to 90% of array filled, C) and network formation does start to develop on the micro sieve array after 72h. Individual neurons connecting to adjacent sieves was observed (D). In addition, to create a "mini-brain", several types of brain-related cells have to be used. Currently, human Neural Progenitor Cells (NPC's) are being cultured and differentiated either into a pure population of neurons or into a mixed population of neurons and glial cells. Furthermore, NPC's from the cerebellum of mouse were cultured and differentiated into Purkinje cells (E). Finally, human astrocytes (F) were cultured alone or co-cultured with SH-SY5Y cells. The differentiation level of all the mentioned cells are measured morphologically and by immunohistochemistry using specific antibodies.

DISSERTATIONS

-

SCIENTIFIC PUBLICATIONS

1. J.P. Frimat, S. Xie, A. Bastiaens, B. Schurink, F. Wolbers, J.M.J. den Toonder and R. Luttge (2015). Advances in 3D neuronal cell culture. *J. Vac. Sci. Technol. B* 33, 06F902.
2. B. Schurink, E.J.W. Berenschot, R.M. Tiggelaar and R. Luttge (2015). Highly uniform sieving structure by corner lithography and silicon wet etching. *Microelectronic Engineering* 144, 12-18 DOI: 10.1016/j.mee.2015.01.027 (S).
3. J.P. Frimat, S. Xie, A. Bastiaens, B. Schurink, F. Wolbers, J.M.J. den Toonder and R. Luttge (2015). Advances in 3D neuronal cell culture. EIPBN 2015 in San Diego, USA, May 26-29.
4. B. Schurink, E.J.W. Berenschot, R.M. Tiggelaar and R. Luttge (2015). Microelectrode array with integrated sieving structure for automated cell positioning. *Micro and Nano Engineering Conference*, The Hague, Netherlands, September 21-24.

PROJECT LEADERS

R Luttge, JMJ den Toonder

RESEARCH THEME

Complex structures of fluids

PARTICIPANTS

B Schurink, PhD student University of Twente, S Xie, PhD student University of Twente, AJ Bastiaens, PhD student Eindhoven University, JP Frimat, Postdoc University Eindhoven, DAM Mustafa, Postdoc University Eindhoven

COOPERATIONS

Prof. dr. JGE Gardeniers, Mesoscale Chemical Systems, MESA+ Institute for Nanotechnology, University of Twente

FUNDED

European Research Council, ERC, no.280281 MESOTAS

University	-
FOM	-
STW	-
NWO Other	-
Industry	-
TNO	-
GTI	-
EU	100 %
Scholarships	-

START OF THE PROJECT

2011

INFORMATION

R Luttge
040 247 5235
r.luttge@tue.nl
www.tue.nl/en/university/departments/mechanical-engineering/the-department/staff/detail/ep/e/d/ep-uid/20135203/

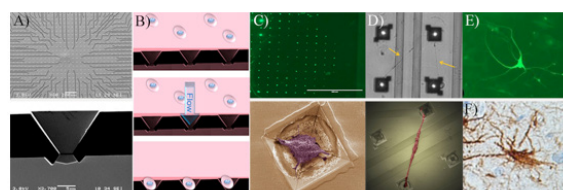

DYNACLEAN: DYNAMIC SELF-CLEANING SURFACES ENABLED BY RESPONSIVE MATERIALS

PROJECT LEADERS

JMJ den Toonder

RESEARCH THEME

Complex dynamics of fluids

PARTICIPANTS

Y Wang, GG Melpignano, E de Jong, PR Onck, MJM den Toonder

COOPERATIONS

Philips Research, RUG

FUNDED

STW	
University	-
FOM	-
STW	100 %
NWO Other	-
Industry	-
TNO	-
GTI	-
EU	-
Scholarships	-

START OF THE PROJECT

2013

INFORMATION

Y Wang
040 247 5706
y.wang2@tue.nl
<http://www.tue.nl/universiteit/faculteiten/faculteit-werktuigbouwkunde/onderzoek/research-groups/microsystems/>

PROJECT AIM

Self-cleaning surfaces are interesting for applications in e.g. lighting, healthcare, personal care products and solar cells. Inspired by nature, current man-made self-cleaning surfaces have permanent micro- and nano-structures. However, these are static and thus vulnerable to contamination and damage. The goal of this work is to create dynamic self-cleaning surfaces, switchable between self-cleaning and non-cleaning by means of (an) external trigger(s).

PROGRESS

Hierarchic micrometer sized base features with nanometer roughness are created, between which a thermo-responsive hydrogel (pNIPAM) is placed. The hydrogel changes its chemical and structural properties upon the additional of water and heat. When at a low temperature, the thermo-responsive hydrogel is hydrophilic (in favor of water), whilst at a high temperature it is hydrophobic. This results in swelling of the hydrogel when in contact with water for low temperature, whilst expelling water for higher temperatures. The swelling of the structured surface has been investigated. It is found that swelling of 20 μm in height occurs for lateral spaced dimensions of 20 μm (200% increase between dry and wet). The water repellency has been measured using contact-angle measurements. Switching in the water repelling properties as a function of temperature has been found.

DISSERTATIONS

-

SCIENTIFIC PUBLICATIONS

-

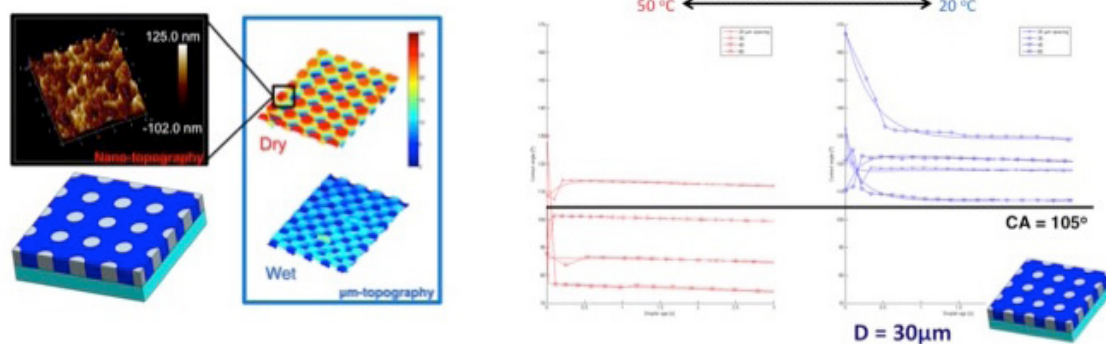

HETEROGENEOUS SENSOR SYSTEMS ON FOIL

PROJECT AIM

Develop basic functions and manufacturing processes for realizing microfluidics-based sweat sensing micro systems which combine the strengths of foil and Si technology.

PROGRESS

The results from evaporation driven pump was published. We have integrated a prototype of the sweat sensor with a pH sensor. Good responses were found in the experiments to show the proof-of-principle by evaporation driven pumping for the sweat sensor. Besides, by modifying the evaporation pump that we have introduced last time, the device can be used as a microflow meter which may possibly indicate the local sweat rate.

DISSERTATIONS

-

SCIENTIFIC PUBLICATIONS

1. C. Nie, A. J. H. Frijns, R. Mandampambal, and J. M. J. den Toonder, "A microfluidic device based on an evaporation-driven micropump," *Biomed. Microdevices*, vol. 17, no. 2, pp. 1–12, Mar. 2015.
2. C. Nie, A. J. H. Frijns, R. Mandampambal, M. A. G. Zevenbergen, and J. M. J. den Toonder, "An evaporation based digital microflow meter," *J. Micromechanics Microengineering*, vol. 25, no. 11, pp. 1–10, Sep. 2015.
3. C. Nie, A. Frijns, M. Zevenbergen, and J. den Toonder, "An integrated flex-microfluidic-Si chip device towards sweat sensing applications," *Sens. Actuators B Chem.*, vol. 227, pp. 427–437, May 2016.

PROJECTLEADERS

JMJ den Toonder, AJH Frijns

RESEARCHTHEME

Complex structures of fluids

PARTICIPANTS

C Nie, A Frijns

COOPERATIONS

Holst Centre, Eindhoven

FUNDED

NanoNextNL
University -
FOM -
STW -
NWO Other 100 %
Industry -
TNO -
GTI -
EU -
Scholarships -

START OF THE PROJECT

2011

INFORMATION

C Nie
040 247 3647
c.nie@tue.nl
www.tue.nl/universiteit/faculiteiten/faculteit-werktuigbouwkunde/onderzoek/research-groups/microsystems/research/microsystems-applications/chuan/

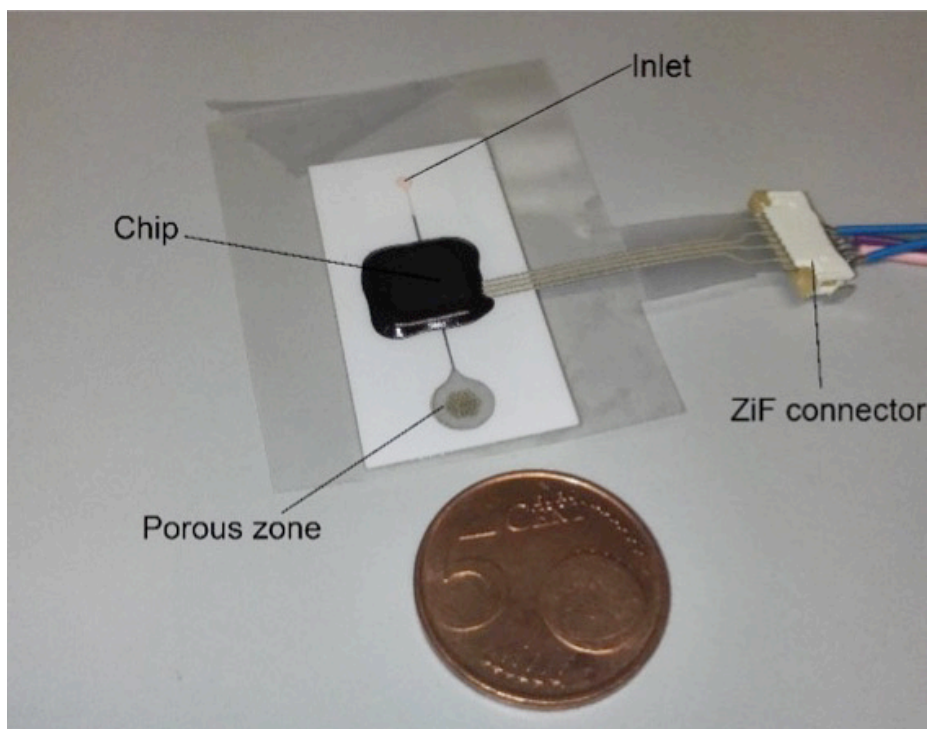

BIOCHIP DESIGN FOR ALGAE MONITORING

PROJECT LEADERS

Y Bellouard, JMJ den Toonder

RESEARCH THEME

Complex structures of fluids

PARTICIPANTS

A Schaap

COOPERATIONS

Norwegian Water Research Institute

FUNDED

Eindhoven University of Technology's

Dept. of Mechanical Engineering

EC Project "Femtoprint" (FP7)

University 90 %

FOM -

STW -

NWO Other -

Industry -

TNO -

GTI -

EU 10 %

Scholarships -

START OF THE PROJECT

2010

INFORMATION

A Schaap

040 247 3647

a.schaap@tue.nl

tue.nl/microsystems

PROJECT AIM

The identification of algae species is useful and important for monitoring water quality and conditions for health and environmental applications. This project aims to develop a chip-based approach to identifying and classifying algae species in water in real-time, using microfluidics with integrated optical and/or other sensors. We use a femtosecond laser to create microchannels and optical waveguides in fused silica, to create integrated optofluidic microdevices on a single substrate.

PROGRESS

This year the focus was on numerical and experimental studies of two methods of sorting algae cells by size and shape in microfluidic channels. We tested the use of both optical and fluidic forces for this task. The optical method uses an optical gradient to move particles across streamlines. The fluidic method relies on the balance of inertial forces and drag forces from Dean flow in a spiral microchannel to sort the algae cells by size and shape. Besides this, we also did characterization studies on the optical algae identification system developed previously, particularly looking at the effects of increasing the flow rate in the device. For example, we examined the effect of flow rate on the self-alignment of high aspect ratio particles in the flow, and on the sensitivity of the device when used as a particle counter. In May 2015, this research was concluded with a dissertation and a successful PhD defense.

DISSERTATIONS

1. Schaap, A.M. (2015). Integrating optics and microfluidics to automatically identify algae species. Eindhoven: Technische Universiteit Eindhoven. ((Co-) promot.: Jaap den Toonder & Yves Bellouard).

SCIENTIFIC PUBLICATIONS

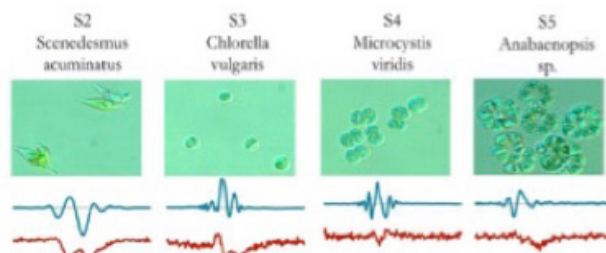
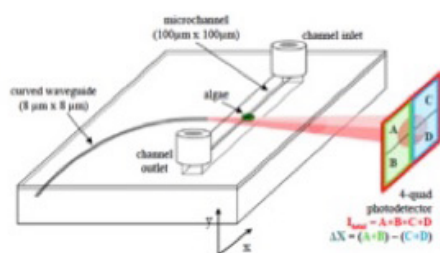

GAS SENSOR MEMBRANE

PROJECT AIM

The PASTEUR project aims to build a disposable tag for food monitoring. Our work focusses on a membrane that will be used to enhance the functionality of the micro-scale gas sensors. The membrane will block solid particles and droplets and remove them from the sensor surface while still allowing the target gas to be transported to the sensor. Additionally it will enhance both the sensitivity and selectivity of the sensor using a perm-selective membrane in combination with a pumping system.

PROGRESS

Experiments were carried out to modify a PDMS surface. By tuning the ablation parameters, we could make it sticky or slippery super-hydrophobic. These surfaces were characterized using SEM, Raman spectroscopy and static and dynamic contact angle measurements. We created a pattern that acted as a drop merger, drop size could be tuned by choosing the tilting angle. We also created a pattern that acted as a drop container.

DISSERTATIONS

-

SCIENTIFIC PUBLICATIONS

-

PROJECTLEADERS

JMJ den Toonder, AJH Frijns

RESEARCHTHEME

Complex structures of fluids

PARTICIPANTS

S van Pelt

COOPERATIONS

Holst Centre

FUNDED

CATRENE, PASTEUR

University -

FOM -

STW -

NWO Other -

Industry -

TNO -

GTI -

EU 100 %

Scholarships -

START OF THE PROJECT

2009

INFORMATION

S van Pelt

040 247 2186

s.v.pelt@tue.nl

www.tue.nl/en/university/departments/mechanical-engineering/research/research-groups/research-group-microsystems/research/microsystems-applications/gas-sensor-window/

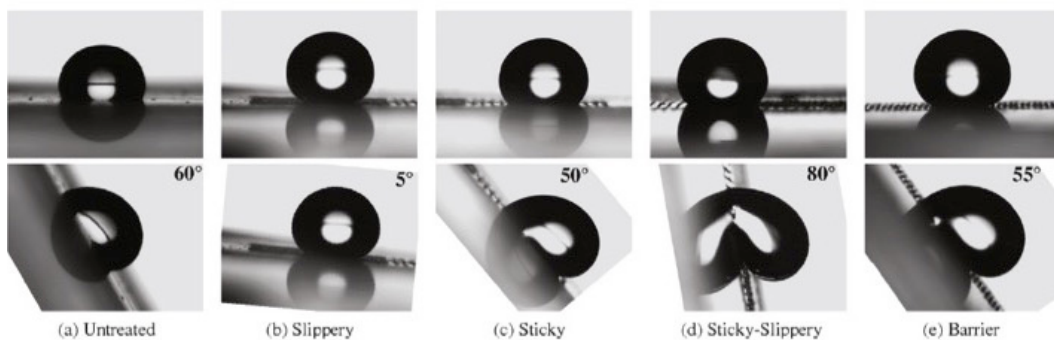

BIO-INSPIRED HAIRY SURFACES FOR ACTUATION OR SENSING, PRODUCED WITH ROLL-TO-ROLL TECHNOLOGY

PROJECT LEADERS

JMJ den Toonder, PD Anderson,
R Cardinaels

RESEARCH THEME

Complex structures of fluids

PARTICIPANTS

Y Wang

COOPERATIONS

-

FUNDED

DPI

University -

FOM -

STW -

NWO Other -

Industry -

TNO -

GTI -

EU 100 %

Scholarships -

START OF THE PROJECT

2011

INFORMATION

Y Wang

040 247 5706

y.wang2@tue.nl

www.tue.nl/universiteit/faculteiten/
faculteit-werktuigbouwkunde/
onderzoek/research-groups/
microsystems/

PROJECT AIM

This project aims to develop novel out-of-cleanroom technologies for manufacturing magnetically actuated artificial cilia. These cilia are integrated into microfluidic systems, and the flow generated by the cilia, actuated with an externally applied magnetic field, is characterized.

PROGRESS

After introducing two methods for magnetic artificial cilia, based on the self-assembly of magnetic microbeads in a magnetic field (published in Lab on a Chip), and based on the formation of magnetic fibers from a precursor of PDMS containing magnetic particles using a magnetic field (published in Microfluidics Nanofluidics), we developed a new large scale roll pulling method for fabrication of artificial cilia. Using an in-house developed setup with a surface modified roll and a moving substrate, filaments can be pulled out from a precursor layer coated on glass containing uncured PDMS and magnetic particles, and form artificial cilia after filament breakup and subsequent curing. These cilia, when integrated in a microfluidic device, could generate flow velocities of over 100 $\mu\text{m/s}$.

DISSERTATIONS

-

SCIENTIFIC PUBLICATIONS

1. Wang, Y., Gao, Y., Wyss, H.M., Anderson, P.D. & Toonder, J.M.J. den. Artificial cilia fabricated using magnetic fiber drawing generate substantial fluid flow. *Microfluidics and Nanofluidics*, 2015.
2. Wang, Y., Cardinaels, R., Toonder, J.M.J. den, Anderson, P.D. A continuous roll-pulling approach for the fabrication of magnetic artificial cilia with microfluidic pumping capability, in preparation.
3. Wang, Y. PhD thesis: Out-of-cleanroom magnetic artificial cilia.

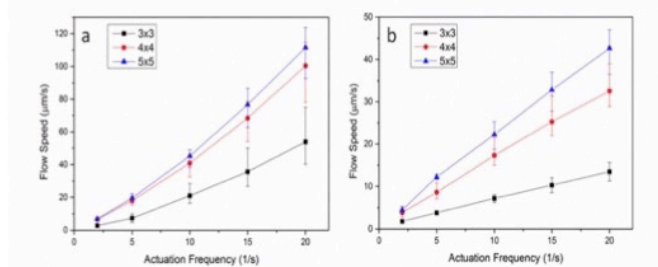
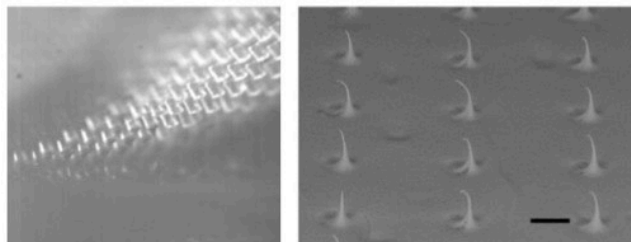





Prof.dr.ir. FN van de Vosse

The Cardiovascular Biomechanics group at the department of Biomedical Engineering aims to promote the use of experimentally validated predictive mathematical modeling, both in diagnosis and selection of therapy in clinical practice as well as in research and development in the medical device industry. The research in the group is divided in 4 areas of which the first is embedded in JMBC.

1. HEMODYNAMICS

Hemodynamic factors such as like local pressure, velocity, wall shear stress and wall deformation are crucial for the proper functioning of the vascular system, the heart and its native valves. These factors play a key role in the genesis of vascular disease and, when measured properly, can also be predictive for the development of cardiovascular disease. Hemodynamics research in the group is focused on the development of mathematical models and the corresponding computational methods based on finite and spectral element approximations. These models are used to understand the functioning and response of the cardiovascular system. The models range from 0D lumped parameter and 1D wave propagation models of the entire cardiovascular system to 3D models of local fluid-structure interaction in specific arterial segments and heart valve dynamics. Both microscopic (blood as a suspension) as well as macroscopic (blood-wall interaction) scales are considered. In vitro laboratory experiments and measurement techniques are designed and used to validate the outcome of the computational simulations.

2. MECHANICS AND ADAPTATION

Cardiovascular mechanics research is focused on the understanding of the mechanical response of vascular and cardiac tissue to mechanical loads, caused by the pulse wave propagation and cardiac contraction, as well as external forces caused by medical interventions.

3. INSTRUMENTATION AND DEVICES

Medical instrumentation and devices like ultrasound image modalities, pressure and flow sensors, particularly those used for advanced diagnostic measurements.

4. CLINICAL RESEARCH

Through pilot or full clinical studies, in which patient data are gathered and used as input for patient specific modelling, evaluation of the predictive value of mathematical models to predict outcome of medical intervention can be performed.

RHEOLOGY OF BLOOD CLOT FORMATION

PROJECT AIM

Blood clots form upon vascular injury in order to prevent blood loss and are involved in the process of wound healing. The structure of the blood clot plays a role in many pathologies and is influenced by the flow conditions under which the clot develops. However, the relation between structural properties influenced by the flow and the macroscopic mechanical properties of the clot is poorly understood. In this project constitutive equations are developed based on the structural properties of the different constituents of the clot to study its mechanical properties under various conditions.

PROGRESS

One of the main structural components of the blood clot is fibrin, a protein that forms a fibrous structure within the blood clot. A constitutive model is developed that describes the formation of the fibrin network in time. The network formation is modeled as a transition from a viscous fluid to a viscoelastic solid, where the transition is governed by the fibrin kinetics. The model is extended by taking into account the non-linear viscoelastic behavior of the network. The strain-stiffening behavior observed in large deformations is incorporated in the solid phase of the model. As validation, rheometry experiments are performed where a fibrin network is formed within the rheometer. Quantitative agreement is found between the model and experimental results. This project has been finished.

DISSERTATIONS

-

SCIENTIFIC PUBLICATIONS

-

PROJECTLEADERS

FN van de Vosse, GWM Peters

RESEARCHTHEME

Complex structures of fluids

PARTICIPANTS

THS van Kempen

COOPERATIONS

TU/e Mechanical Engineering

TU/e Applied Physics

FUNDED

TU/e High Potential Research

Program: Blood in Motion

University 100 %

FOM -

STW -

NWO Other -

Industry -

TNO -

GTI -

EU -

Scholarships -

START OF THE PROJECT

2011

INFORMATION

THS van Kempen

t.h.s.v.kempen@tue.nl

CONTINUUM MODELLING OF BLOOD CLOT FORMATION AND GROWTH

PROJECT LEADERS

FN van de Vosse

RESEARCH THEME

Complex dynamics of fluids

PARTICIPANTS

F Storti

COOPERATIONS

TU/e Mechanical Engineering

TU/e Applied Physics

FUNDED

TU/e High Potential Research

Program: Blood in Motion

University 100 %

FOM -

STW -

NWO Other -

Industry -

TNO -

GTI -

EU -

Scholarships -

START OF THE PROJECT

2010

INFORMATION

F Storti

f.storti@tue.nl

PROJECT AIM

Hemostasis is the complex process necessary to prevent blood loss. It involves the interplay between biochemical and physical processes, which normally keep the blood in a fluidic state and repair the walls of veins and arteries in case of injury. When this happens a blood clot forms around the injury. The phenomenon of blood clotting mainly consists of two mechanisms:

1. dynamics of platelet and chemical species;
2. clot growth and remodelling.

The aim of the project is to create a mathematical model that describes the blood clot formation and growth. Particular attention is given to the interaction between the blood flow and the porous clot.

PROGRESS

The initial formation of the clot is modelled through a system of convection-diffusion-reaction equations. Unactivated platelets, activated platelets, chemical activators and chemical inhibitors are modelled as concentrations. All these factors represent the onset of the coagulation process. Once the clot is formed, it is represented by means of an elastic solid, which interacts with the flow around it through basic FSI. The clot growth is represented by mesh update (ALE method) and once in a while remeshing is necessary. To represent the porosity of the clot a Brinkman term is included in the Navier-Stokes equations for the fluid and the elastic solid is modified into a porous elastic solid. This project has been finished.

DISSERTATIONS

-

SCIENTIFIC PUBLICATIONS

-

PROBING RED BLOOD CELL MECHANICS

PROJECT AIM

Because of the high volume contents of red blood cells (RBCs) in blood, mechanics of a single RBC plays a large role in plasma mixing and lateral transport of its components. Therefore, a characterization of the dynamical parameters of RBCs under different flow conditions is needed. Our strategy involves estimation of mechanical properties of the RBC using an inverse analysis which combines both numerical and experimental tools. A RBC is deformed under elongational flow. Advantage of this experimental method is that there is no contact between a solid and the cell membrane, which would complicate the analysis, especially during dynamic deformations. To create a setup with elongational flow, a cross-slot microfluidics device is built (left figure). Rigid channels in SU-8 photoresist on glass are sealed with a PDMS foil. The foil also serves as a deflecting membrane for the valves, which enable position control of the cell. Piezo-electric elements are used in closed loop control to actuate the valves. To change the stress on the RBC dynamically, a pulsatile microfluidics pump is designed, built, and tested.

PROGRESS

Active repositioning of the cell is necessary to perform repetitive measurements. However, a linear feedback loop seems to be inadequate. For the design of a suitable feedback system with feedforward control, a numerical tool is developed. This involves 2D FEM simulations of the cross-slot (Stokes flow), in which lumped parameter models that represent the channel hydraulics, are added to the boundary conditions of the in- and outflow channels. By matching the experimental open-loop system identification measurements with the simulations, the parameters for the lumped elements are fitted. Hence, this hybrid model is used as a platform to design a non-linear controller. This project has been finished.

DISSERTATIONS

-

SCIENTIFIC PUBLICATIONS

-

PROJECTLEADERS

FN van de Vosse, ACB Bogaerds,
PD Anderson

RESEARCHTHEME

Complex dynamics of fluids

PARTICIPANTS

RCH van der Burgt

COOPERATIONS

TU/e Mechanical Engineering
TU/e Applied Physics

FUNDED

TU/e High Potential Research
Program: Blood in Motion
University 100 %
FOM -
STW -
NWO Other -
Industry -
TNO -
GTI -
EU -
Scholarships -

START OF THE PROJECT

2009

INFORMATION

R van der Burgt
r.c.h.v.d.burgt@tue.nl

TRANSITIONAL FLOW THROUGH ARTIFICIAL HEART VALVES

PROJECT LEADERS

FN van de Vosse, MA Hulsen
ACB Bogaerds

RESEARCH THEME

Mathematical and computational
methods for fluid flow analysis

PARTICIPANTS

AC Verkaik

COOPERATIONS

TU/e Mechanical Engineering

FUNDED

TU/e	
University	100 %
FOM	-
STW	-
NWO Other	-
Industry	-
TNO	-
GTI	-
EU	-
Scholarships	-

START OF THE PROJECT

2008

INFORMATION

AC Verkaik
A.C.Verkaik@tue.nl

PROJECT AIM

Distal to artificial heart valves transitional (transition to turbulence) flow with small scale local velocity fluctuations can be found. To compute transitional flow spectral elements can be used, however we also want to compute accurately the fluid stress near the deforming structure. Therefore, this study will focus on the implementation of a coupling method between spectral and finite elements to compute fluid-structure interaction for transitional flow through artificial heart valves.

PROGRESS

In previous periods we proposed a fully Coupled Overlapping Domain (COD) method to couple the fixed grid fluid domain with an Arbitrary Lagrangian Eulerian (ALE) moving grid fluid domain. This allows for an optimal conformal coupling between the fluid elements and the structural elements. The convergence of the spectral elements was proved. Last year we focused on testing the fluid-fluid coupling of the COD method for several benchmark problems and some first test problems with fluid-structure interaction were made. This project has been finished.

DISSERTATIONS

-

SCIENTIFIC PUBLICATIONS

-



CENTRE FOR ANALYSIS, SCIENTIFIC COMPUTING AND APPLICATIONS (CASA)



Prof.dr.ir. B Koren



Prof.dr.ir. M Peletier



Prof.dr.ir. JJM Slot

TU/e's Centre for Analysis, Scientific Computing and Applications (CASA) embodies the chairs Applied Analysis and Scientific Computing, which both participate in the J.M. Burgerscentrum.

CASA's research objective is to develop new and improve existing mathematical methods - both analytical and numerical - for a wide range of applications in science and engineering. Extensive collaborations exist with researchers in other disciplines, at universities, large technological institutes as well as industries, both nationally and internationally. Current CASA research related to fluid dynamics concerns aerodynamics, aeroacoustics, magnetohydrodynamics, fluid-structure interactions, porous media flows, viscous and viscoelastic flows, free-surface flows, particle flows and shape optimization.

COMPARISON BETWEEN HYPERVELOCITY IMPACT OF PARTICLES AND PULSED LASER THERMAL IMPACT MODELS ON GLUE BONDED LAMINATES UNDER CRYOGENIC CONDITIONS

PROJECT AIM

The final goal of this project is to study hypervelocity impacts into laminated materials. For that purpose we extend the capabilities of the Smoothed Particle Hydrodynamics (SPH) method, modify existing algorithms and create a computational tool.

PROGRESS

The results of the last year consist of the following. First, a derivation of SPH schemes in the context of measure-valued evolutions and continuum mechanics. Second, fine-tuning of the LimeSPH code such that it is now possible to numerically simulate the hypervelocity impact experiments, that we performed at the Fraunhofer EMI in Freiburg, Germany, in the end of 2014. And finally, the writing of the doctoral thesis.

DISSERTATIONS

-

SCIENTIFIC PUBLICATIONS

1. I.Zisis, R.Messahel, B. van der Linden, A.Boudlal and B.Koren; Validation of robust SPH schemes for multiphase fully compressible media; Int. J. Multiphysics Vol. 9, 2015.
2. I.Zisis, B. van der Linden, C.Giannopapa and B.Koren; On the derivation of SPH schemes for shocks through inhomogeneous media, Int. J. Multiphysics Vol. 9, 2015.

PROJECTLEADERS

B Koren

RESEARCHTHEME

Mathematical and computational methods for fluid flow analysis

PARTICIPANTS

I Zisis, BJ van der Linden

COOPERATIONS

Laboratory of Mechanics, Lille-France, Applied Analysis chair, CASA, TU/e, Institute of High Speed Dynamics, Fraunhofer EMI Freiburg-Germany, FLMC, TU Delft

FUNDED

Materials Innovation Institute m2i and Laboratory for Industrial Mathematics Eindhoven, LIME BV.
University 75 %
FOM -
STW -
NWO Other -
Industry 25 %
TNO -
GTI -
EU -
Scholarships -

START OF THE PROJECT

2011

INFORMATION

I Zisis
i.zisis@tue.nl

FLOW INDUCED INSTABILITIES AND FLOW LINER INTERACTION

PROJECT LEADERS

SW Rienstra, JJM Slot

RESEARCH THEME

Mathematical and computational methods for fluid flow analysis

PARTICIPANTS

D Kumar Singh

COOPERATIONS

FLOWAIRS-(Acoustics Laboratory of the Université du Maine-France)

FUNDED

Marie Curie ITN (EU-FP7)

University	-
FOM	-
STW	-
NWO Other	-
Industry	-
TNO	-
GTI	-
EU	100 %
Scholarships	-

START OF THE PROJECT

2012

INFORMATION

D Kumar Singh
040 247 5865
d.k.singh@tue.nl
www.win.tue.nl/~sjoerdr/

PROJECT AIM

The project mainly concerns the mathematical modelling of sound absorbing lining material (physically correct descriptions in time domain; thermo-viscous effects of liners consisting of stacked pores; the coupling with an unstable boundary layer), and the effect of the boundary layers on the sound produced by the flow.

PROGRESS

Vortical Perturbations in Shear Flow, Scattered at a Hard Wall - Pressure Release Wall Transition: This work presents a canonical model for the vorticity scattering in incompressible turbulent flow with linear shear as it passes a hard-to-pressure release (impedance = 0) wall transition. The incompressible near field solution, obtained by the Wiener Hopf technique, is matched to the acoustic far field. The scattered sound is found to depend strongly on the flow shear/frequency rate being higher or lower than unity. It is found to be most intense for high shear. The limit Z (impedance) = 0 gave enormous insight in the problem and confirmed the previously sound results when the wall had finite impedance.

Non-linear N wave source Impedance model: This work is about the systematic solution of non-linear Helmholtz resonator equation when it is driven by an N wave type source close to the resonance. Such sources are very common in aircraft engines at takeoff condition. The asymptotic solution was used to calculate the impedance of the boundary comprising of the resonators to form the wall lining. The lining surface was found to be behaving like a hard wall for higher harmonics of sound source.

DISSERTATIONS

-

SCIENTIFIC PUBLICATIONS

1. Vortical Perturbations in Shear Flow, Scattered at a Hard Wall - Pressure Release Wall Transition, with Sjoerd W. Rienstra. The 22nd International Congress on Sound and Vibration ICSV22, 12-16 July 2015, Florence, Italy.
2. Non-linear N wave source Impedance model, EURONOISE, 31 May-3 June, 2015, Maastricht, The Netherlands.

EUROS WORK PACKAGE 1.4: WIND-FARM-WAKE INTERACTIONS

PROJECT AIM

The goal of this project is to start the development of a computational tool for the aerodynamic optimization under uncertainty of offshore wind farms. The variables to be optimized are: (i) wind-farm layout (plan form and turbine spacing), and (ii) yaw and pitch angles of individual turbines. Last five years, significant progress has been made in computational methods for: (i) offshore wind-farm-wake aerodynamics, (ii) shape optimization and (iii) uncertainty quantification. The time is perfectly right now to combine experts and algorithms, to start the development of an optimization algorithm for optimal wind-farm wakes under uncertainty.

PROGRESS

The first months of the project were partly devoted to study of the relevant literature and partly to the development of a computational tool for solving the mathematical equations describing the flow through a wind-farm, i.e., the Navier-Stokes equations. In the study of the literature the focus has been on energy-conserving discretization methods and ditto time-integration methods. Moreover, the available literature on immersed boundary methods has been consulted. The immersed boundary methods are anticipated to lead to a more realistic modelling of rotor-blade aerodynamics than the commonly used actuator approaches.

DISSERTATIONS

-

SCIENTIFIC PUBLICATIONS

-

PROJECT LEADERS

B Koren

RESEARCH THEME

Mathematical and computational methods for fluid flow analysis

PARTICIPANTS

dr. ME Hochstenbach, dr.ir. MJH Anthonissen (supervision)
MSc. R Beltman (PhD student)

COOPERATIONS

Research cooperation with: CWI, TU Delft and WUR.

Users: Ballast-Nedam, Deltares, DNV-GL, ECN, ENECO, Fugro, Heerema, IHC, KNMI, Van Oord, Sytems Navigator

FUNDED

STW	
University	-
FOM	-
STW	100 %
NWO Other	-
Industry	-
TNO	-
GTI	-
EU	-
Scholarships	-

START OF THE PROJECT

2015

INFORMATION

B Koren
040 247 2080
b.koren@tue.nl
<http://www.stw.nl/nl/content/p14-03-euros-%E2%80%93-excellence-uncertainty-reduction-offshore-wind-systems>

POROFLOW: NON-EQUILIBRIUM MODELS FOR FLOW IN HETEROGENEOUS POROUS MEDIA

PROJECT LEADERS

I Sorin Pop, B Koren

RESEARCH THEME

Mathematical and computational methods for fluid flow analysis

PARTICIPANTS

Koondanibha Mitra (TU/e), Xiulei Cao (TU/e), Prof. Dr. Iuliu Sorin Pop (Hasselt), Prof. Dr.Ir. Barry Koren (TU/e), Prof. Dr. C.J. van Duijn (TU/e, Utrecht)

COOPERATIONS

Prof. Dr. F.A. Radu (Bergen)
Prof. Dr. S.M. Hassanizadeh (Utrecht)
Prof. Dr. Ing. R. Helmig (Stuttgart)
Prof. Dr. C. Rohde (Stuttgart)
Dr. K. Kumar (Bergen)

FUNDED

Shell-NWO/FOM program
Computational Sciences for Energy Research
University -
FOM -
STW -
NWO Other 50 %
Industry 50 %
TNO -
GTI -
EU -
Scholarships -

START OF THE PROJECT

2015

INFORMATION

I Sorin Pop
+32 11 268581
sorin.pop@uhasselt.be

PROJECT AIM

This project addresses issues related to the mathematical modelling, numerical simulation and upscaling of flow in porous media. The main focus is on non-equilibrium models in heterogeneous and fractured systems, where dynamic effects or hysteresis are included in the difference between the two phase pressures, and/or in the relative permeabilities.

PROGRESS

In the first five months of the project we have started the analysis for one-phase (unsaturated) flow models with hysteresis in the capillary pressure. We considered regularized models and showed the existence of travelling waves, connecting given states. Furthermore, we analyzed the behavior of such solutions when the regularization parameter is approaching 0. Finally, we have constructed a numerical scheme for the original model (a system of partial differential equations). The numerical experiments confirm the analytical results.

DISSERTATIONS

-

SCIENTIFIC PUBLICATIONS

1. X. Cao and I.S. Pop, Degenerate two-phase porous media flow model with dynamic capillarity, *J. Differential Equations* Vol. 260 (2016), pp 2418–2456.
2. C.J. van Duijn, X. Cao and I.S. Pop, Two-phase flow in porous media: dynamic capillarity and heterogeneous media, *Transp. Porous Med.* (available online).

Pressure-saturation relationship in the phase plane. The red curve has been determined numerically by solving the model in the original formulation, as a system of differential equations. The inflow values display an unstable spiral-type behavior and the outflow values a sink-type, as predicted by the travelling wave analysis.

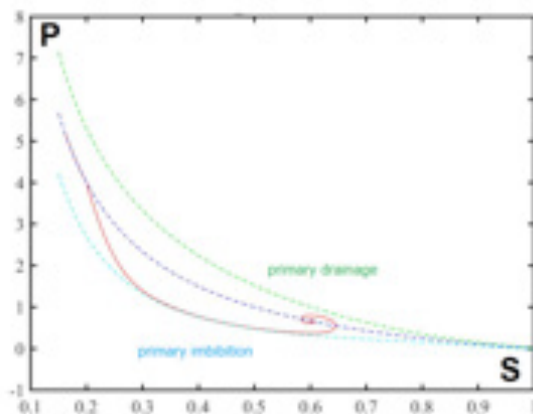

OPTIMAL OFFSHORE WIND FARMS (OPTIWIND)

PROJECT AIM

The project is primarily aimed at developing sophisticated numerical techniques for studying the flow of incompressible fluids. The developed numerical methods will be used for investigating turbulent wind farm wakes and for designing optimal wind farms.

PROGRESS

So far we have worked on the spatial discretization techniques for the incompressible Navier-Stokes equations primarily using second-order accurate finite volume methods on uniform staggered grids. These discretization methods provide us with better accuracy on coarse computational grids as compared to standard methods. Currently we are working on employing the developed techniques for spatial discretization with suitable time integration methods so as to have a more accurate and stable Navier-Stokes solver.

DISSERTATIONS

-

SCIENTIFIC PUBLICATIONS

1. N. Kumar, J.H.M. ten Thije Boonkamp, B. Koren: A sub-cell discretization method for the convective terms in the incompressible Navier-Stokes equations. Spectral and high order methods for partial differential equations ICOSAHOM , Lecture notes in computational science and engineering (106) 295—303.
2. N. Kumar, J.H.M. ten Thije Boonkamp, B. Koren: Flux approximation scheme for the incompressible Navier-Stokes equations using local boundary value problems. European conference on numerical mathematics and advanced applications ENUMATH 2015, Ankara (accepted).

PROJECTLEADERS

B Koren, JHM ten Thije Boonkamp

RESEARCHTHEME

Mathematical and computational methods for fluid flow analysis

PARTICIPANTS

N Kumar

COOPERATIONS

-

FUNDED

Shell-NWO-FOM Programme
Computational Sciences for Energy
Research

University	-
FOM	100 %
STW	-
NWO Other	-
Industry	-
TNO	-
GTI	-
EU	-
Scholarships	-

START OF THE PROJECT

2013

INFORMATION

N Kumar
040 247 8190
n.kumar@tue.nl
[www.tue.nl/en/university/
departments/mathematics-and-
computer-science/the-department/
staff/detail/ep/e/d/ep-uid/20134132/](http://www.tue.nl/en/university/departments/mathematics-and-computer-science/the-department/staff/detail/ep/e/d/ep-uid/20134132/)

EUROS WORK PACKAGE 1.3: UNCERTAINTY QUANTIFICATION IN WIND AND WAVES

PROJECT LEADERS

DT Crommelin (CWI,UvA), B Koren

RESEARCH THEME

Mathematical and computational methods for fluid flow analysis

PARTICIPANTS

ME Hochstenbach, AW Eggels

COOPERATIONS

Research cooperation with: CWI, TU Delft and WUR. Users: Ballast-Nedam, Deltares, DNV-GL, ECN, ENECO, Fugro, Heerema, IHC, KNMI, Van Oord, Sytems Navigator

FUNDED

STW	
University	-
FOM	-
STW	58 %
NWO Other	42 %
Industry	-
TNO	-
GTI	-
EU	-
Scholarships	-

START OF THE PROJECT

2015

INFORMATION

B Koren
040 247 2080
b.koren@tue.nl
<http://www.stw.nl/nl/content/p14-03-euros-%E2%80%93-excellence-uncertainty-reduction-offshore-wind-systems>

PROJECT AIM

The goal of the project is to develop a fully stochastic approach to include correlation of wind and waves in calculating the loads on wind turbines, by making use of the probability distribution in wind loads and existing wind-wave models. The challenge is to develop an efficient and realistic modelling by enabling treatment of different sources of uncertainty in one single computational space. When this is combined with smart sampling techniques, calculation times in uncertainty quantification will be drastically reduced.

PROGRESS

During the first months of the project, literature on uncertainty quantification was studied and some of the most widely used methods have been programmed in MATLAB, which include several Monte-Carlo methods and stochastic collocation methods on both full and sparse grids. After this, the extension of stochastic collocation to correlated inputs was investigated. At this moment, the research focuses on clustering methods to deal with correlated inputs.

DISSERTATIONS

-

SCIENTIFIC PUBLICATIONS

-

CHALLENGES IN SMOOTHED PARTICLE HYDRODYNAMICS

PROJECT AIM

SPH is a grid-free, particle based technique and is especially suited for treating problems with free surfaces, multiphase flows, high velocity impacts, crack propagation or large deformations. It has been applied with success in many fields in science and engineering. However, there are still challenges ahead. E.g., to achieve reliable and accurate solutions, the computational accuracy, consistency, stability and convergence need further study. Also the treatment of domain boundaries and boundary conditions has triggered attention, but have not been dealt with properly yet.

PROGRESS

We continued our research on accurate estimates for second derivatives. The paper describing our results was submitted to a scientific journal and is currently under review. Furthermore, our previous work on clustering and particle collisions resulted in a paper submitted to a journal. Also this paper is currently under review. Finally, we are exploring 'incompressible SPH' by applying it to a problem in which a liquid slug is accelerated by a very high (relative to gravity) pressure gradient. Points of interest are the shape of the slug and the pressure exerted by it on a wall in case of a collision.

DISSERTATIONS

-

SCIENTIFIC PUBLICATIONS

1. Korzilius S.P., Schilders W.H.A., Anthonissen M.J.H. (2015); An improved CSPM approximation for multi-dimensional second-order derivatives. 10th International SPHERIC Workshop, Parma (Italy), June 2015, pp. 39-44.

PROJECTLEADERS

WHA Schilders, MJH Anthonissen,
AS Tijsseling

RESEARCHTHEME

Mathematical and computational
methods for fluid flow analysis

PARTICIPANTS

SP Korzilius

COOPERATIONS

-

FUNDED

VICI grant 639.033.008

University -

FOM -

STW -

NWO Other -

Industry -

TNO -

GTI -

EU -

Scholarships -

START OF THE PROJECT

2012

INFORMATION

SP Korzilius

040 247 3987

s.p.korzilius@tue.nl

EVOLUTION EQUATIONS FOR SYSTEMS GOVERNED BY SOCIAL INTERACTIONS

PROJECT LEADERS

A Muntean, MA Peletier

RESEARCH THEME

Complex dynamics of fluids

PARTICIPANTS

JHM Evers

COOPERATIONS

SC Hille (Leiden), RC Fetecau (Burnaby, Canada), L Ryzhik (Stanford, USA), MH Duong (Warwick, UK), I Zisis (Eindhoven)
BJ van der Linden (Eindhoven)

FUNDED

NWO Graduate Programme 2010
University -
FOM -
STW -
NWO Other 100 %
Industry -
TNO -
GTI -
EU -
Scholarships -

START OF THE PROJECT

2011

INFORMATION

A Muntean
Adrian.muntean@kau.se

PROJECT AIM

The research aims at studying models in which social interactions occur: e.g. in groups of pedestrians, flocks of birds or schools of fish. Inspiration is taken from measure theory, continuum mechanics and thermodynamics. The research covers a new direction within both the Department of Mathematics and Computer Science, and the Institute for Complex Molecular Systems (ICMS). It fits very well in the philosophy of the ICMS (multi-disciplinarity, complexity). Also, it matches with the new trend towards a more theoretical understanding (in terms of measures) of particle systems and their continuum limits, driven by MA Peletier and his group.

PROGRESS

Together with SC Hille we worked on better mathematical understanding (and analysis) of suitable boundary conditions for measure-valued evolutions. The results were published in the Journal of Differential Equations. A follow-up paper, treating measure-dependent velocity fields, has been submitted for publication. In 2014, JHM Evers spent two months in Canada. The results on anisotropy due to a field of vision (with RC Fetecau and L Ryzhik) were published in Nonlinearity in 2015. A paper was submitted on the theoretical foundations of the numerical method SPH (with MH Duong, I Zisis and BJ van der Linden). JHM Evers defended his PhD Thesis on 1 June 2015; the degree was awarded Cum Laude. With his graduation this project came to an end.

DISSERTATIONS

1. J.H.M. Evers. "Evolution Equations for Systems Governed by Social Interactions". PhD Thesis, Eindhoven University of Technology (2015).

SCIENTIFIC PUBLICATIONS

1. J.H.M. Evers, R.C. Fetecau and L. Ryzhik. "Anisotropic interactions in a first-order aggregation model". Nonlinearity, 28: pp. 2847-2871 (2015).
2. J.H.M. Evers, S.C. Hille and A. Muntean. "Mild solutions to a measure-valued mass evolution problem with flux boundary conditions". Journal of Differential Equations, 259(3): pp. 1068-1097 (2015).
3. J.H.M. Evers, S.C. Hille and A. Muntean. "Modelling with measures: Approximation of a mass-emitting object by a point source". Mathematical Biosciences and Engineering, 12(2): pp. 357-373 (2015).

MATHEMATICAL AND NUMERICAL ANALYSIS FOR NON-EQUILIBRIUM TWO PHASE FLOW MODELS IN POROUS MEDIA

PROJECT AIM

We investigate non-equilibrium mathematical models for flows in porous media, where dynamic effects and hysteresis are included in the capillary pressure – saturation relationship. The focus is on the mathematical and numerical analysis for such models. In particular, heterogeneous media are being considered, and appropriate coupling conditions between two homogeneous blocks are derived.

PROGRESS

The uniqueness of weak solutions to non-equilibrium models for flow in porous media is proved first for a scalar, pseudo-parabolic equation. Then this is extended to two-phase flow models, including both dynamic and hysteresis effects. Further, the existence of weak solutions for the two-phase flow model is obtained, where degeneracy in the higher order term is allowed. For heterogeneous media, the conditions at interfaces separating two homogeneous blocks are derived. Finally, a multi-point flux approximation finite volume scheme is analyzed for the non-equilibrium model. The convergence of the scheme has been proved and an implementation was made to confirm the mathematical analysis.

DISSERTATIONS

-

SCIENTIFIC PUBLICATIONS

1. F. Radu, K..Kumar, J.M. Nordbotten and I.S. Pop. A convergent mass conservative numerical scheme based on mixed finite elements for two phase flow in porous media, CASA Report 15-39, Eindhoven University of Technology 2015.
2. X. Cao, S.F. Nematdjieua and I.S. Pop. Two phase flow in porous media with dynamic effects in the capillary pressure: finite volume analysis. CASA Report 15-33, Eindhoven University of Technology, 2015.
3. X. Cao and I.S. Pop. Degenerate two-phase porous media flow model with dynamic capillarity. *J. Differ. Equ.*, 260(3):2418-2456, 2016.
4. C.J. van Duijn, X. Cao and I.S. Pop. Two-phase flow in porous media: dynamic capillarity and heterogeneous media. *Transp. Porous Media*, 110:1-26, 2015.
5. X. Cao and I.S. Pop. Two-phase porous media flows with dynamic capillary effects and hysteresis: uniqueness of weak solutions. *Comput. Math. Appl.*, 69:688-695, 2015.
6. X. Cao and I.S. Pop. Uniqueness of weak solutions for a pseudo-parabolic equation modeling two phase flow in porous media. *Appl. Math. Lett.*, 46:25-30, 2015.

PROJECTLEADERS

CJ van Duijn

RESEARCHTHEME

Mathematical and computational methods for fluid flow analysis

PARTICIPANTS

X Cao, CJ van Duijn, IS Pop, K Mitra

COOPERATIONS

Prof.dr.ir. S.M. Hassanizadeh (Utrecht)
Dr. P.A. Zegeling (Utrecht)
Prof.dr.ir. R. Helmig (Stuttgart)
Prof.dr. C. Rohde (Stuttgart)
Prof. dr. F.A. Radu (Bergen)
Prof. dr. J. M. Nordbotten (Bergen)
Prof. dr. K. Kumar (Bergen)
Prof. dr. B. Schweizer (Dortmund)
Dr. S. Nematdjieu (Erlangen)

FUNDED

China Scholarship Council
University -
FOM -
STW -
NWO Other -
Industry -
TNO -
GTI -
EU -
Scholarships 100 %

START OF THE PROJECT

2011

INFORMATION

I Sorin Pop
040 247 5516
i.pop@tue.nl
www.win.tue.nl/~pop

APPLIED ANALYSIS



Prof.dr.ir. CJ van Duijn



Prof.dr. JJM Slot

The Eindhoven Applied Analysis group focuses on modeling, analysis of nonlinear differential equations and related computational methods. This diverse expertise is applied to a broad spectrum of problems arising in the engineering sciences, physics and industry. The philosophy is to contribute to the solution of relevant problems in these applied sciences as well as to participate in the development of the underlying mathematical framework. At the moment the main areas of applications are fluid mechanics, rheology, material science (including polymers) and porous media. For example:

POROUS MEDIA

Porous media are (micro-) structures that appear in many disciplines of science and engineering, like ground water hydrology, soil mechanics, petroleum engineering, bioremediation, agricultural science, tissue engineering, or paper production. Typical for such problems is that different phenomena take place on different scales. One of the research topics is upscaling microstructures to macromodels. Examples are problems from hydrology, like groundwater flow, in particular seawater intrusion in coastal waters, contamination of aquifers, or subsurface storage of materials.

AERO ACOUSTICS

One of the many measures taken to reduce the noise of aircraft engines is the application of acoustic lining in the inlet and bypass duct. In order to optimize the damping properties we need to model the sound propagation through the duct. By utilizing the inherent slow variation of a typical flow duct we found an analytic asymptotic solution of the problem that appeared to compare very favorably with proven numerical solutions. This solution was the starting point of a series of similar solutions for related cases, while it has been used to produce a superior matching procedure to connect CFD-type source data to the acoustic field, which is now being used throughout Europe to support CAA implementations.

RHEOLOGY

Rheology is the branch of science focusing on the flow and deformation behavior of complex materials. Complex materials often contain long molecules and/or particles that give them particular flow and deformation behavior in comparison with simple fluids like water or simple solids like pure metals. Examples can be found in industry, the environment, living systems and around the house: paints, polymer processing, production of tires, ink, glues, pharmaceutical -, agricultural - and cosmetic products, in oil production, production of photographic materials, displays and magnetic tapes, food products such as mayonnaise, cheese, margarine, domestic products like toothpaste and liquid detergents, mud, clay, blood and saliva. As in all branches of science also in rheology, in addition to experiment, mathematical modeling and numerical simulation play a very important role. From its inception in the beginning of the last century, when it involved almost exclusively continuum mechanics and constitutive modeling, rheology heavily relies on disciplines belonging to classical applied mathematics, such as differential equations, functional analysis, perturbation theory etc. However, with the increasing focus on the relationship between microscopic structure/processes and macroscopic properties of these complex materials nowadays, probability theory and in particular the theory of stochastic processes has become an essential discipline too. Currently, two focal areas of interest are the constitutive modeling of concentrated solutions of main chain liquid crystalline polymers and that of melts of entangled arbitrarily branched polymers.

DYNAMIC CAPILLARITY IN POROUS MEDIA

PROJECT AIM

This work addresses mathematical and numerical analysis questions related to non-standard porous media flow models, and investigate the effect of different capillary pressure assumptions. In particular, we seek for non-standard entropy solutions to two-phase porous media flow problems, as limit cases when the capillary effects vanish.

PROGRESS

We obtained the existence of weak solutions for the nonlinear and degenerate mathematical equation modelling two-phase flow porous media, involving dynamic effects in the capillary pressure. Furthermore, we introduced an extra unknown: capillary pressure, and transformed the equation into different systems. Then we proved the equivalence of different forms of the model equation. New numerical schemes were introduced and tested with different numerical settings. A-posteriori error estimates are obtained for the complete two-phase flow model, but in the equilibrium/standard case.

DISSERTATIONS

1. Fan, Y. (2012). Dynamic Capillarity in Porous Media - Mathematical Analysis. Eindhoven: Technische Universiteit Eindhoven. (Supervisor: C.J. van Duijn and I.S. Pop).

SCIENTIFIC PUBLICATIONS

-

PROJECT LEADERS

CJ van Duijn

RESEARCH THEME

Mathematical and computational methods for fluid flow analysis

PARTICIPANTS

Y Fan, CJ van Duijn, IS Pop

COOPERATIONS

Dr. C. Cances (Paris), Dr. M. Vohralik (Paris), Dr. C. Choquet (Marseille), Prof. dr.ir. S.M. Hassanizadeh (Utrecht), Prof. dr.ir. R. Helmig (Stuttgart), Prof. dr. C. Rohde (Stuttgart), Prof. dr. A. Mikelić (Lyon), Prof. dr. ir. L.A. Peletier (Leiden)

FUNDED

TUE	
University	100 %
FOM	-
STW	-
NWO Other	-
Industry	-
TNO	-
GTI	-
EU	-
Scholarships	-

START OF THE PROJECT

2008

INFORMATION

IS Pop
040 247 5516
i.pop@tue.nl

CONSTITUTIVE MODELING OF CONCENTRATED SOLUTIONS OF MAIN-CHAIN LIQUID CRYSTALLINE POLYMERS

PROJECT LEADERS

JJM Slot

RESEARCH THEME

Complex dynamics of fluids

PARTICIPANTS

O Matveichuk

COOPERATIONS

Prof. dr. J. Molenaar (WUR),

Prof. dr. S. Picken (TUD),

Teijin Aramid R&D

FUNDED

Teijin-Aramid BV

University -

FOM -

STW -

NWO Other -

Industry 100 %

TNO -

GTI -

EU -

Scholarships -

START OF THE PROJECT

2008

INFORMATION

JJM Slot

040 247 4381

j.j.m.slot@tue.nl

PROJECT AIM

The primary objective of this project is to develop a molecularly based constitutive model for the rheological behavior of concentrated solutions of main-chain liquid crystalline polymers (LCP) that may show nematic order. The model will be restricted to monodomain (single director) morphologies and the main focus will be on the role that chain flexibility plays in this behavior.

PROGRESS

The code for the simulations of the rod-spring-bead model for the description of concentrated solutions of LCP was developed. The model incorporates hairpins and allows large deviations from highly-ordered state. The model is also capable of treating possible entanglements between polymer chains with hairpins. The code is validated by comparing the results of simulations with the predictions of the earlier developed model for highly-ordered LCP solutions. The results of these simulations were presented at the Annual European Society of Rheology (AERC2012). The results of simulations are in agreement with the available experimental data. The second half of 2012 was primarily devoted to writing the thesis that summarizes the results achieved during the time of this project.

DISSERTATIONS

-

SCIENTIFIC PUBLICATIONS

1. AERC2012 conference proceedings. O. Matveichuk, J.J.M. Slot. Constitutive modeling of highly ordered solutions of main-chain liquid crystalline polymers containing hairpins.

CONSTITUTIVE MODELING OF ARBITRARY BRANCHED POLYMER MELTS

PROJECT AIM

The primary objective of this project is to develop a molecularly based constitutive model for the rheological behavior of polymer melts consisting of arbitrary branched polymer molecules. An industrially relevant and prime example of such a system is provided by a melt of low-density polyethylene (ldPE). As such a system shows such an extreme variation in molecular composition, a description of this composition can only be given in statistical terms. Hence, the idea is to describe such a system by a finite set (ensemble) of representative molecular structures (topologies). Such an ensemble can be obtained via a combination of kinetic modeling and Monte Carlo simulation. This work on kinetic modeling and Monte Carlo simulation is done at the University of Amsterdam in a twin PhD project (not part of the JMBC).

PROGRESS

In 2012 we have focused on the idea of using a statistical representation of ldPE molecules, where the concept of seniority plays the key role. By seniority we mean a segment "depth" from the topological exterior of a molecule. This quantity is simply the number of segments that connects a given segment to the retracting chain end responsible for its relaxation. From our point of view, it is the best measure of topological structures within the ensemble of arbitrary branched polymers. From numerical experiments on theoretical ldPE samples we have observed that segments of seniorities up to 7 compose around 97% of the system mass. Thus, we can reduce the calculation of the linear stress-relaxation response of a complex melt by taking into account only relaxation of such segments. In other words, from every complex branch in a molecule we only explicitly treat the relaxation of a part of it and let the rest be implicitly relax by constraint release. As we want to develop a new computational approach based on the earlier work of Evelyne van Ruymbeke, we have started validation of her model for the ensembles of well described molecules: monodisperse stars, blends of stars, blends of stars and linears, asymmetric stars, symmetric h-polymers, asymmetric h-polymers.

DISSERTATIONS

-

SCIENTIFIC PUBLICATIONS

-

PROJECTLEADERS

JJM Slot

RESEARCHTHEME

Complex dynamics of fluids

PARTICIPANTS

V Shchetnikava

COOPERATIONS

Prof. dr. ir. E. van Ruymbeke, UCL, Belgium, Prof. dr. P.D. Iedema, UvA

FUNDED

Dutch Polymer Institute (DPI)

University	-
FOM	-
STW	-
NWO Other	100 %
Industry	-
TNO	-
GTI	-
EU	-
Scholarships	-

START OF THE PROJECT

2009

INFORMATION

JJM Slot
040 247 4381
j.j.m.slot@tue.nl

SECOND GENERATION OF INTEGRATED BATTERIES

PROJECT LEADERS

P Notten, MA Peletier, IS Pop

RESEARCH THEME

Complex dynamics of fluids

PARTICIPANTS

K Kumar, TL van Noorden, P Notten,
MA Peletier, IS Pop

COOPERATIONS

Prof. R. Helmig (Stuttgart)
Prof. W. Jäger (Heidelberg)
Prof. A. Mikelić (Lyon)
Prof. F.A. Radu (Bergen)
Dr. M. Neuss-Radu (Erlangen)

FUNDED

STW	
University	-
FOM	-
STW	100 %
NWO Other	-
Industry	-
TNO	-
GTI	-
EU	-
Scholarships	-

START OF THE PROJECT

2008

INFORMATION

K Kumar
kkumar@ices.utexas.edu

S Pop
040 247 5516
i.pop@tue.nl

PROJECT AIM

The project is related to the development of all-solid state rechargeable batteries having a high storage capacity. Such devices have a complex 3D geometry for the electrodes to enhance the surface area. The challenges are in the development of the appropriate technologies for the formation of these electrodes. In particular we focus on chemical vapor deposition processes (CVD), with the aim of getting a deeper understanding of the reactions taking place in a complex geometry.

PROGRESS

Depending on the size of the reaction domain, the changes in the pore structure that are due to the deposition process may or may not be neglected. In mathematical terms, the models are defined in a fixed, respectively variable geometry, when the deposition layer generates a free boundary at the pore scale. We have developed mathematical models for both situations and carried out numerical simulations for both the fixed geometry and variable geometry showing a good agreement with the experimental results obtained for the deposition of Titanium dioxide inside trenches of different diameters. This work has implied determining the physical and chemical parameters. For the multi-scale computations, numerical methods inspired from domain decomposition ideas have been proposed and the convergence of the scheme has been proved. Computing the full solution in a domain with oscillating boundary requires a lot of computational effort, as one has to achieve an accuracy that agrees with the scale of oscillations. To approximate these solutions, one defines equations in a simpler domain, where flat boundaries but modified boundary conditions approximate the rough one. The two situations mentioned before were considered: the fixed geometry case, and the time dependent geometry at the microscale (free boundaries). We have derived an approximating (effective) model where a flat boundary is replacing the oscillatory boundary, but defining an effective boundary condition. In the fixed geometry case, we provide rigorous mathematical proofs for the upscaling procedure. The second case, when we take into account the geometry changes at the microscale, is more involved, and we use formal asymptotic methods to derive these boundary conditions. Further, to understand the flow in a domain with variable geometry, we have considered a thin strip with reactions taking place at the lateral boundaries of the strip under dominant transport conditions. We have derived upscaled equations for the solute concentration, which are similar to the Taylor dispersion and we have performed numerical simulations to compare the upscaled equations with other simpler upscaled equations. We have further studied the rigorous homogenization process for the reactive flows for a periodic array of cells and proved the validity of upscaled equations. These reactive flows model the crystal precipitation and dissolution processes in a porous medium. Our results are in agreement with the macroscale equations proposed in the literature. In addition, numerical methods, for instance, mixed finite element method, to compute the solution have been proposed and the proofs for the convergence of these schemes have been obtained..

DISSERTATIONS

1. Upscaling of Reactive Flows, Sep 2012, CASA, TU Eindhoven.

SCIENTIFIC PUBLICATIONS

-



MULTIPHASE RECTORS GROUP



Prof.dr.ir. JAM Kuipers



Prof.dr.ir. M van Sint Annaland

The research group SMR participates amongst others in the OSPT and the JMBC for fluid mechanics and focuses on fundamentals of the discipline of chemical reaction engineering. Our main area of interest is the quantitative description of transport phenomena (including fluid flow) and the interplay with chemical transformations in multiphase chemical reactors. The generation of new knowledge and the development of new reactor models with improved predictive capability for this industrially important class of chemical reactors constitutes an important goal of our research activities. Through the intended co-operation with other (application oriented) research groups, both fundamental aspects and those closely related to applications will be studied through concerted action. The main research topics of the new group SMR can be divided into the following three areas: Multiphase Reactors, Advanced Experimental Techniques and Novel Reactors, which will be discussed below in more detail.

An important area of attention is the development of advanced reactor models for multiphase reactors with industrial relevance. At present our research focuses on the hydrodynamics in these reactors because it is generally recognized that the lack of understanding of the flow phenomena is one of the central difficulties in the design and scale-up of multiphase reactors. In the near future the interplay of flow phenomena with chemical reactions will be studied in great detail. We use various types of CFD models (both commercial codes but mostly "in house" made codes) to study the relevant hydrodynamic phenomena at all relevant length and time scales (i.e. at the microscopic, mesoscopic and macroscopic scale). In our group both multifluid models are being developed and models which treat the dispersed phase (particles, bubbles or droplets) in a discrete manner accounting for possible encounters between the dispersed elements.

The second important area of our research deals with the development of advanced experimental techniques to measure key quantities (i.e. local volume fractions and velocities of the dispersed and continuous phase). As an example we can mention the development of the digital particle image velocimetry technique to measure in a non-intrusive manner the velocity map of both the liquid phase and dispersed gas bubbles in (dense) gas-liquid dispersions. This type of flow very often arises in a variety of gas-liquid contactors/reactors. In this area we co-operate with specialists within the J.M. Burgerscentrum for fluid mechanics. Of course this research activity is intimately connected to the first research topic. Our third important area of research deals with the development of novel (multiphase) reactors with emphasis on integration and intensification of relevant process steps. As an example we can mention here the Rapid Reaction Cycling Reverse Flow (RRCRF) which integrates (in a thermal sense) endothermic and exothermic heterogeneously catalyzed chemical reactions where the endothermic reaction causes rapid (reversible) catalyst deactivation. These types of chemical reaction systems often arise in practice for instance in the production of lower alkenes from the corresponding alkanes via heterogeneously catalyzed dehydrogenation. The knowledge and tools developed within the other two areas of attention provide a sound basis to place this research activity on a firm footing.

MODIFICATION OF KINETIC THEORY FOR GRANULAR FLOW BY INCLUDING FRICTION

PROJECT AIM

The roughness of the granular materials has been shown to have a significant effect on stresses. The particles can rotate due to surface friction during collisions. Attempts to quantify the friction effect have been somewhat limited. In rapid granular flows, the particle-wall collisions cause random fluctuations of the grain velocities, which are responsible for the transport of momentum and fluctuation energy through the flow. The aim of this project is to modify the current KTGF by including particle rotation and particle surface friction, and derive appropriate boundary conditions distinguishing between sliding and sticking collisions in the two fluid model.

PROGRESS

Currently, the derivation of the theory and implementation in the in-house code have been accomplished. Validation of the modified KTGF model followed from a comparison with the DPM model, in which friction can be modeled with reasonable accuracy, and also by comparing with one-to-one PIV-DIA experiments.

DISSERTATIONS

-

SCIENTIFIC PUBLICATIONS

1. L. Yang, J. T. Padding, and J.A.M. Kuipers. Comparison of a Two-Fluid model and an Euler-Lagrange model for simulation of dense gas-fluidized beds. Proceedings of the 11th International Conference on Computational Fluid Dynamics in the Minerals and Process Industries CSIRO, 7-9 December 2015, Melbourne Australia.
2. Modification of Kinetic Theory for Frictional Spheres, Part I: Two-fluid model derivation and numerical implementation, 2015. (submitted to Chemical Engineering and Science).
3. Modification of Kinetic Theory of Granular Flow for Frictional Spheres, Part II: Model validation, 2015 (submitted to Chemical Engineering and Science).

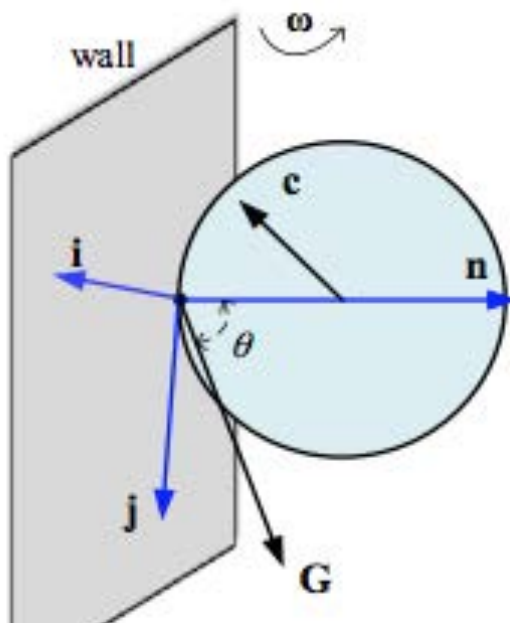

Sketch for particle-wall collision

PROJECTLEADERS

JAM Kuipers

RESEARCHTHEME

Complex dynamics of fluids

PARTICIPANTS

L Yang, JT Padding, JAM Kuipers

COOPERATIONS

-

FUNDED

European Research Council (ERC)

University -

FOM -

STW -

NWO Other -

Industry -

TNO -

GTI -

EU 100 %

Scholarships -

START OF THE PROJECT

2013

INFORMATION

L Yang

040 247 8023

l.yang@tue.nl

PREDICTIVE MODELING OF POLYOLEFIN REACTORS

PROJECT LEADERS

JAM Kuipers, M van Sint Annaland,
NG Deen

RESEARCH THEME

Mathematical and computational
methods for fluid flow analysis

PARTICIPANTS

M Banaei, Z Li, JAM Kuipers,
M van Sint Annaland, NG Deen

COOPERATIONS

-

FUNDED

Dutch Polymer Institute (DPI)	
University	-
FOM	-
STW	-
NWO Other	-
Industry	100 %
TNO	-
GTI	-
EU	-
Scholarships	-

START OF THE PROJECT

2012

INFORMATION

M Banaei
040 247 8026
m.banaei@tue.nl

PROJECT AIM

1. Extension of numerical models for prediction of hydrodynamics and heat transfer in polymerization reactors
2. Developing the PIV/DIA measurements for pressurized gas fluidized beds and quantitative investigation of the heat effects in polymerization reactors (Endoscopic particle image velocimetry, EPIV)

PROGRESS

1. Designing an endoscope for capturing hydrodynamics of pressurized fluidized beds.
2. Validation of EPIV technique and finding the most suitable settings for using this technique.
3. Implementation and verification of energy equations into the existent two-fluid model.
4. Error analysis on the reconstruction techniques for electrical capacitance tomography.
5. Comparison between electrical capacitance tomography data and simulation results by two fluid model (TFM).
6. Studying the heat transfer mechanism between bubble and emulsion phases and correlating this phenomena just after bubble formation for fluidized beds with coarse particles.
7. Proposing, implementing and validating of a new approach for calculation of particle's mixing rate with two fluid model.

DISSERTATIONS

-

SCIENTIFIC PUBLICATIONS

1. On the accuracy of Landweber and Tikhonov reconstruction techniques, AIChE Journal, M. Banaei, M. van Sint Annaland, J.A.M. Kuipers, N.G. Deen, 2015, Vol. 61 (12), 4102-4113.
2. Bubble-emulsion heat transfer coefficient in gas-solid fluidized bed using two fluid model, CSIRO 11th conference on CFD in the minerals and process industries, December 2015.

BUBBLES ON THE CUTTING EDGE: EXPERIMENTAL INVESTIGATION ON MICRO-STRUCTURED BUBBLE COLUMNS

PROJECT AIM

The aim of the project is to construct a laboratory scale micro-structured bubble column reactor with a wire mesh to demonstrate proof of principle. The impact of wire mesh on bubble cutting, hydrodynamics characteristics is to be studied in-depth experimentally using advanced measurement techniques such as Particle image velocimetry and X-ray tomography. X-ray tomography experiments are done in co-operation with HZDR, Dresden, Germany. The performance of the wire mesh is compared with Sulzer packing used in the industry.

PROGRESS

Experiments were done in micro-structured square bubble column using fast X-ray tomography for various superficial gas and liquid velocities. Dual plane measurements were done for five heights in the column to obtain insight into the overall hydrodynamics of a micro-structured bubble column. This is used to obtain information on bubble size distribution and velocity in the square bubble column. Experiments were also done to study the effect of wire mesh surface properties (hydrophilic or hydrophobic) on single bubble cutting in a glycerol-air system. The experiments will be used to validate 3D-direct numerical simulations.

DISSERTATIONS

-

SCIENTIFIC PUBLICATIONS

1. K. Thiruvalluvan Sujatha, B.G.J. Meeusen, N. G. Deen, and J. A. M. Kuipers. "Experimental Studies of Bubbly Flow in a Pseudo-2D Micro-Structured Bubble Column Reactor Using Digital Image Analysis." *Chemical Engineering Science* (2015).

PROJECTLEADERS

NG Deen

RESEARCHTHEME

Mathematical and computational methods for fluid flow analysis

PARTICIPANTS

K Thiruvalluvan Sujatha, NG Deen, JAM Kuipers

COOPERATIONS

HZDR, Dresden, Germany.

FUNDED

European Research Council (ERC)

University	-
FOM	-
STW	-
NWO Other	-
Industry	-
TNO	-
GTI	-
EU	100 %
Scholarships	-

START OF THE PROJECT

2012

INFO0MATION

NG Deen
040 247 3681
N.G.Deen@TUE.nl

OPEN MICRO-STRUCTURED RANDOM PACKING IN GLS REACTORS FOR FISCHER-TROPSCH MULTI-SCALE REACTOR MODELLING

PROJECT LEADERS

JAM Kuipers

RESEARCH THEME

Mathematical and computational
methods for fluid flow analysis

PARTICIPANTS

V Chandra, EAJF Peters,

JAM Kuipers

COOPERATIONS

-

FUNDED

Netherlands Center for Multiscale
Catalytic Energy Conversion (MCEC
University -

FOM -

STW -

NWO Other 100 %

Industry -

TNO -

GTI -

EU -

Scholarships -

START OF THE PROJECT

2015

INFORMATION

V Chandra

06 33897154

v.chandra@tue.nl

PROJECT AIM

The Fischer-Tropsch process is widely applied to convert a variety of resources, such as gas, biomass and coal, to fuels. The reactions in this process are very fast, which makes that transport to the catalyst, which performs the reaction, is often limiting the reaction rate. As a result, the process is not optimally efficient, but even worse, the product composition will deviate. In this project, we will design a new catalytic reactor with a very accessible structured solid foam catalyst, optimizing the transport properties on all length scales, from the nanometer scale of the active site where the reaction occurs up to the meter scale of the reactor itself.

PROGRESS

The project began on Oct 1 2015. Literature survey was done to understand heterogeneous catalysis in open structured catalysts. Currently working on 2 dimensional heat transfer using Immersed Boundary Methods.

DISSERTATIONS

-

SCIENTIFIC PUBLICATIONS

-

Structuring a catalytic reactor for optimal performance:

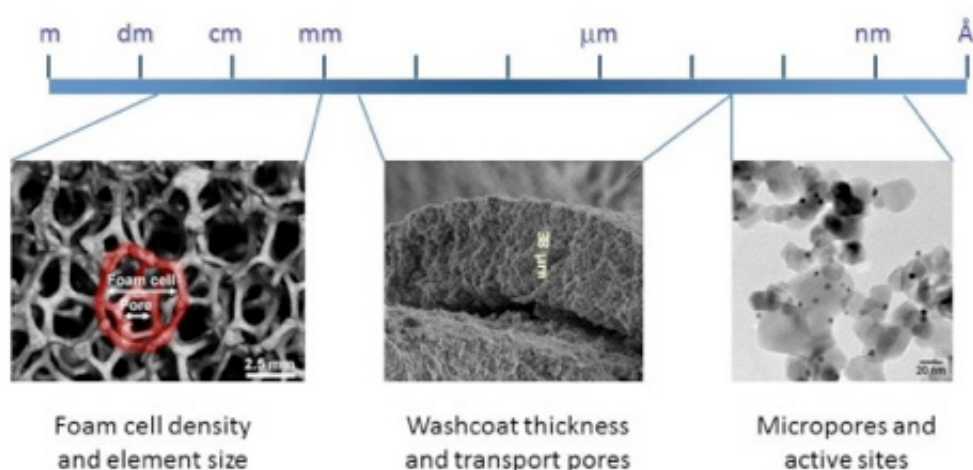

PROJECT AIM

In the ECN MILENA Process, biomass is gasified by an indirect route comprising of a system of two coupled reactors. The performance of both interlinked reactors (bubbling fluidized bed reactor and riser reactor) is investigated in detail in relation to their respective operating conditions, especially focusing on the heat and oxygen transport in the system, and the effect of the residence time of gas and particles. Advanced experimental techniques PIV/DIA is used to study the hydrodynamics and to quantify the rate of heat and oxygen transport. An extended phenomenological model is developed and used for process optimization and scale up effects.

PROGRESS

Remaining issues concerning the novel High Temperature Endoscopic-Laser PIV/DIA (HT-ePIV/DIA) were solved. Experiments with different gases to study the influence of temperature on the hydrodynamics of dense gas-solids fluidized beds up to 400 °C were done. Preliminary results showed an important influence of temperature on the solids circulation patterns (see Figure 1). Additional research on the influence of temperature on the minimum fluidization conditions has shown that the minimum fluidization velocity depends strongly on the minimum fluidization emulsion porosity (ϵ_{mf}), which increases for small Archimedes numbers. As a first application, HT- ePIV/DIA was used to measure ϵ_{mf} at different temperatures.

DISSERTATIONS

-

SCIENTIFIC PUBLICATIONS

1. I. Campos Velarde, J. Muller, F. Gallucci, M. van Sint Annaland “High Temperature Endoscopic-Laser PIV/DIA: A technique for the study of hydrodynamics of gas-solid fluidized beds”. Oral Presentation. 10th European Congress of Chemical Engineering - Nice, France, 2015.

PROJECTLEADERS

M van Sint Annaland, F Gallucci

RESEARCHTHEME

Complex dynamics of fluids

PARTICIPANTS

I Campos Velarde

COOPERATIONS

-

FUNDED

ADEM Project	
University	-
FOM	-
STW	-
NWO Other	100 %
Industry	-
TNO	-
GTI	-
EU	-
Scholarships	-

START OF THE PROJECT

2011

INFORMATION

I Campos Velarde
040 247 3685
i.camposvelarde@tue.nl

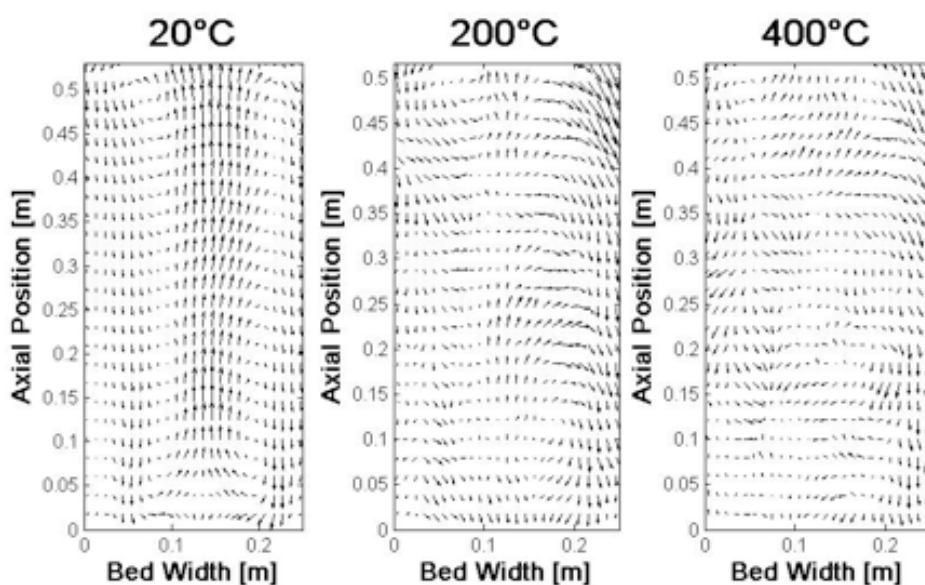

Solids mass flux profiles of gas-solids fluidized beds operated at different temperatures but the same excess velocity.

UNRAVELLING THE ORIGIN OF THE REDOX KINETICS BEHAVIOUR OF OXYGEN CARRIERS IN CHEMICAL LOOPING COMBUSTION

PROJECT LEADERS

I Roghair, F Gallucci, M van Sint Annaland

RESEARCH THEME

Complex dynamics of fluids

PARTICIPANTS

Maria Angel San Pio Bordeje

COOPERATIONS

-

FUNDED

NWO

University -

FOM -

STW -

NWO Other 100 %

Industry -

TNO -

GTI -

EU -

Scholarships -

START OF THE PROJECT

2013

INFORMATION

MA San Pio Bordeje

040 247 8184

m.a.san.pio.bordeje@tue.nl

PROJECT AIM

The project objectives includes:

- Detailed characterization of oxygen carriers and development of improved particle models that link redox kinetics/mass transfer processes to morphological and structural changes during the reduction and oxidation cycles;
- Extension of the particle models with thermodynamics and their verification and validation;
- Experimental investigation in packed bed CLC setups (testing different oxygen carriers) and comparison with simulations where the new particle models have been embedded in available reactor models for packed bed CLC.

PROGRESS

An extensive experimental study of CuO/Al₂O₃ was carried out to explain the drop in the reaction rate in the redox kinetics after approximately 80% conversion in several different oxygen carriers. From this work, a paper has been sent for revision leading to a new strategy in the development of numerical models, now including effective transport terms (i.e. diffusion) for oxygen vacancies and oxygen solid diffusion. A model based on oxygen solid diffusion and oxygen vacancies was developed being able to predict the redox kinetics and the drop in reaction rate at different temperatures. This model is based on some assumptions to simplify the model. A paper about it has also been written. An extensive unsteady state model is being developed to be able to predict not only the redox kinetics but also the oxygen uncoupling effect and the influence of high operating pressures on the redox kinetics.

DISSERTATIONS

-

SCIENTIFIC PUBLICATIONS

- San Pio, M.A.; Roghair, I.; Gallucci, F.; van Sint Annaland, M. On the kinetics of Cu-based oxygen carriers for chemical looping combustion, Applied Catalysis B:Environmental (2015) [Presented as oral presentations in: 23rd Process Intensification Network 2015, 10th European Congress of Chemical Engineering (ECCE10) 2015].
- San Pio, M.A.; Roghair, I.; Gallucci, F.; van Sint Annaland, M. Grain model to predict the redox kinetics of oxygen carriers including solid diffusion limitations and oxygen vacancies, Chemical Engineering Journal (2016) [Presented as oral presentations in: 6th High Temperature Solid Looping Cycles Network Meeting 2015, CHAINS 2015, ISCRE-14 2016].
- San Pio Bordeje, M.A., Roghair, I., Gallucci, F. & Sint Annaland, M. van (2015). High pressure behaviour of CuO/Al₂O₃ and Ilmenite (Fe₂O₃/Ti₂O₅) as oxygen carriers for Chemical Looping applications. On going. [It will be presented as oral in: CHEMREACTOR-22, 19th -23rd September 2016, London, England].

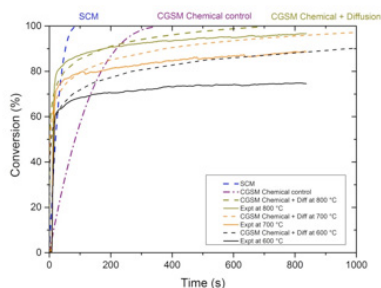

MICRO-MECHANICS OF WET SOLIDS IN GAS-SOLID CONTACTORS

PROJECT AIM

This project is aimed at investigating the dynamic behavior of gas-particle processes involving liquid injection through a combined experimental and numerical study. Based on the detailed information obtained from the experiments and numerical simulations, we are able to identify the mechanisms of energy dissipation, sticking and transfer of mass and momentum during a collision of a wet particle, and to provide quantitatively descriptive closure equations that can be used in coarse-grained models.

PROGRESS

The numerical study of the mechanisms of wet particle collisions is conducted with the aid of a combined Volume of Fluid (VOF) / Immersed Boundary Method (IBM). This model allows us to describe, without any prior assumptions the dynamics of a particle colliding with a flat wall or another dry or wet particle. This model was thoroughly verified through a large set of different test cases for different multiphase flow systems (e.g. bubbly flow, slurry flow, bubbles interacting with a single wire and bubbles interacting with a wire mesh). Simulations of a spherical particle colliding with a solid wall covered by a thin liquid layer are performed. Figure 1 shows some example snapshots when collision occurs, and compares the velocity trajectories between simulation results and experimental measurements. A very good agreement is obtained with respect to the overall energy lost.

DISSERTATIONS

-

SCIENTIFIC PUBLICATIONS

-

PROJECT LEADERS

JAM Kuipers

RESEARCH THEME

Complex dynamics of fluids

PARTICIPANTS

Y Tang, NG Deen, JAM Kuipers

COOPERATIONS

Prof.dir.-Ing.Habil. S. Heinrich

Ir. B. Crüger

FUNDED

STW, DFG

University -

FOM -

STW 100 %

NWO Other -

Industry -

TNO -

GTI -

EU -

Scholarships -

START OF THE PROJECT

2015

INFORMATION

JAM Kuipers

040 247 4158

J.A.M.Kuipers@TUE.nl

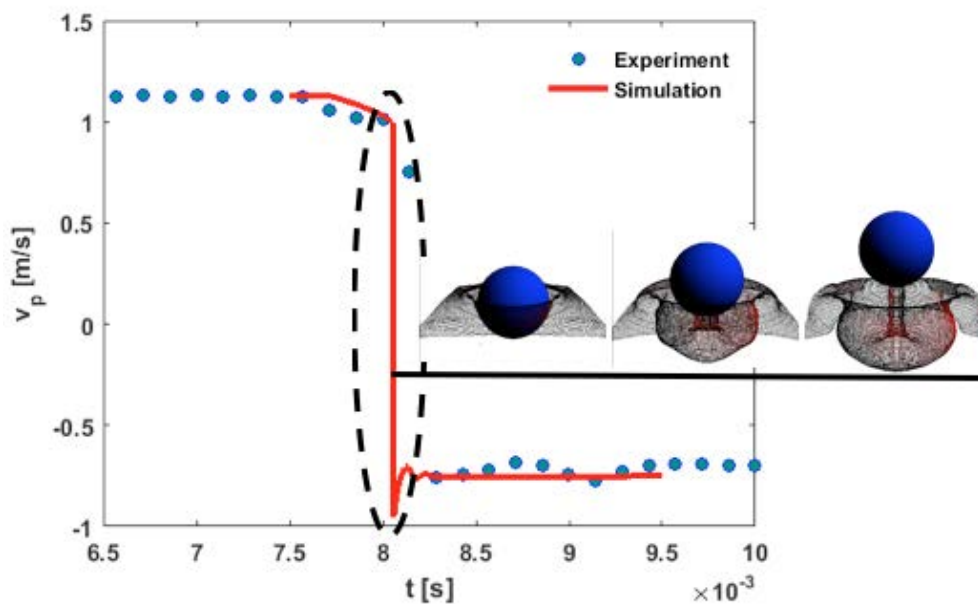

Trajectories of downwards velocity of a 1.74mm glass particle colliding with a wall covered by a 400 μ m layer of water. Snapshots are from the simulation.

NOVEL DISCRETE ELEMENT MODEL FOR ARBITRARY SHAPED NON-SPHERICAL PARTICLES

PROJECT LEADERS

JAM Kuipers

RESEARCH THEME

Mathematical and computational methods for fluid flow analysis

PARTICIPANTS

LJH Seelen, JT Padding,

JAM Kuipers

COOPERATIONS

-

FUNDED

European Research Council (ERC)

University -

FOM -

STW -

NWO Other -

Industry -

TNO -

GTI -

EU 100 %

Scholarships -

START OF THE PROJECT

2012

INFORMATION

LJH Seelen

040 247 5707

L.J.H.Seelen@tue.nl

PROJECT AIM

The main goal of this study is to develop a new discrete element method (DEM) that can describe granular materials that have an arbitrary shape. The method will be used to describe granular flows in rotating drums and hoppers.

PROGRESS

In the last year a collision detection model for convex non-spherical particles has been developed. A broad-phase collision detection strategy has also been implemented and an improved quaternion based integration scheme is developed. The non-spherical DEM method can now be used with arbitrary convex particles, modeled by convex polyhedra. This class of particle shapes is highly relevant because it can represent sand-like particles. With this class of particles, simulations on static packings are being carried out.

DISSERTATIONS

-

SCIENTIFIC PUBLICATIONS

-

INFLUENCE OF WALL CORRUGATION ON MASS TRANSFER IN LIQUID CATALYTIC REACTORS

PROJECT AIM

In many catalytic reactors, a liquid flow is used to enhance the mass transfer to and from catalytic sites dotted on solid surfaces. Solid surfaces are usually corrugated on length scales of micrometers. In this project we will perform a fundamental investigation of the coupled convection-diffusion-reaction mechanisms in the boundary layer near corrugated walls. This will lead to correlations for sub-grid-scale corrections to the mass transfer rates.

PROGRESS

A theoretical study of the new technique of Stochastic Rotation Dynamics has been done. A working code for this method of particle based simulations is has been made and verified using some well-established results. Switching the diffusion coefficient of different solvents involved in catalytic reaction is currently being studied by switching the mass of the involved particles.

DISSERTATIONS

-

SCIENTIFIC PUBLICATIONS

-

PROJECT LEADERS

JAM Kuipers, JT Padding,
RA van Santen

RESEARCH THEME

Mathematical and computational
methods for fluid flow analysis

PARTICIPANTS

A Sengar, JAM Kuipers, JT Padding,
RA van Santen

COOPERATIONS

-

FUNDED

Netherlands Center Multiscale
Catalytic Energy Conversion (MCEC)

University -

FOM -

STW -

NWO Other 100 %

Industry -

TNO -

GTI -

EU -

Scholarships -

START OF THE PROJECT

2015

INFORMATION

A Sengar

040 247 7321

a.sengar@tue.nl

Wall corrugations at boundary layer

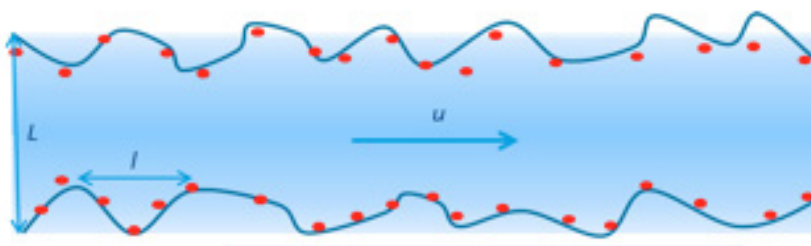

DIRECT NUMERICAL SIMULATION OF BOILING HEAT TRANSFER IN MICROCHANNELS

PROJECT LEADERS

JAM Kuipers, CWM van der Geld,
JGM Kuerten

RESEARCH THEME

Mathematical and computational
methods for fluid flow analysis

PARTICIPANTS

A Rajkotwala, EAJF Peters,
JAM Kuipers, CWM van der Geld,
JGM Kuerten

COOPERATIONS

-

FUNDED

STW, Industrial partners
University -
FOM -
STW 75 %
NWO Other -
Industry 25 %
TNO -
GTI -
EU -
Scholarships -

START OF THE PROJECT

2015

INFORMATION

A Rajkotwala
06 33886096
a.rajkotwala@tue.nl

PROJECT AIM

To carry out meso-scale simulations of contactless and contactful boiling processes for controlled evaporation in microchannels. An inhouse 3D Front Tracking (FT) method will be extended to include phase transition. The resulting FT scheme will be modified to incorporate Diffuse Interface Model (DIM) as a dynamic sub-grid model to properly account for micro-scale effects (for e.g. bubble coalescence). Simulations of the proposed test cases (Figures 1 and 2) will be carried out and results will be validated against experimental data. Closure laws will be developed which will be utilized to set up engineering model for industrial partners.

PROGRESS

The project has been recently started in October, 2015. A detailed literature survey about front tracking schemes is carried out and modifications are proposed in the interface reconstruction procedure to facilitate simulation of interface coalescence and breakup.

DISSERTATIONS

-

SCIENTIFIC PUBLICATIONS

-

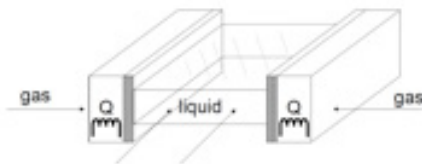

Schematic of contactless boiling test section

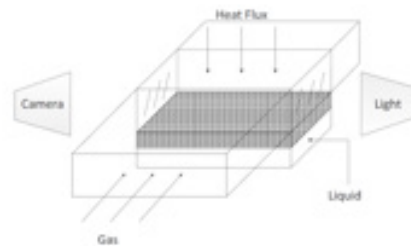

Schematic of contactful boiling test section

INTERFACIAL DYNAMICS IN MULTIPHASE FLOW THROUGH POROUS ROCK

PROJECT AIM

The dynamics of interfaces in multiphase flow through porous media is complex. A novel CFD method based on Voronoi cells is proposed for the study of such multiphase flows. This enables investigation of supra-pore-scale mechanisms that determine the dynamics of oil in rock in secondary and surfactant-enhanced oil recovery. The method will be validated using in-house micro-fluidic experiments. The final goal is to perform large scale parallelized simulations of multiphase in digitized rock samples.

PROGRESS

A detailed literature survey has been carried out on Voronoi cells construction algorithms, geometric properties and different type of CFD solvers built on it. We have developed a compressible Lagrangian CFD solver validated it with basic test cases. We have also developed some models to accurately find the viscous forces on Voronoi grids. Current work involves the development of incompressible CFD solver using same approach. Simultaneously, we are also studying the consistency and convergence of discrete differential operators (gradients, divergence and Laplacian) on Voronoi grids.

DISSERTATIONS

-

SCIENTIFIC PUBLICATIONS

-

PROJECT LEADERS

EAJF Peters, JT Padding

RESEARCH THEME

Mathematical and computational methods for fluid flow analysis

PARTICIPANTS

H Patel, JAM Kuipers

COOPERATIONS

Shell

FUNDED

FOM, Shell	
University	-
FOM	50 %
STW	-
NWO Other	-
Industry	50 %
TNO	-
GTI	-
EU	-
Scholarships	-

START OF THE PROJECT

2015

INFORMATION

EAJF Peters
040 247 3122
E.A.J.F.Peters@tue.nl

PREDICTIVE MODELING OF POLYOLEFIN REACTORS

PROJECT LEADERS

JAM Kuipers, NG Deen, M van Sint Annaland

RESEARCH THEME

Mathematical and computational methods for fluid flow analysis

PARTICIPANTS

Z Li, M Banaei, JAM Kuipers, NG Deen, M van Sint Annaland

COOPERATIONS

DPI

FUNDED

Dutch Polymer Institute (DPI)

University -

FOM -

STW -

NWO Other -

Industry 100 %

TNO -

GTI -

EU -

Scholarships -

START OF THE PROJECT

2012

INFORMATION

Z. Li

040 247 8027

z.z.li@tue.nl

PROJECT AIM

To extend the discrete particle model and multi-fluid model with heat and mass balances to obtain an accurate description of polymerization processes on a lab-scale system and bench scale system under actual process conditions, i.e. involving reaction, significant heat production and high pressures.

PROGRESS

DPM (discrete particle model) simulations for fluidized bed with heat production. A constant volumetric heat source term has been implemented in the heat transfer model. Firstly the mono-dispersed particles are used in the simulations to perform the influences of the operation condition on the heat transfer and particle temperature distribution. The results have been summarized in two publications. Later on, Particles with Gaussian size distribution have been taken into consideration to investigate hot spots formation in the olefin polymerization reactors. It is found that these fine particles with high heat producing which are located above the free-board or at the side walls can be overheated and lead to form hot spots. To validate the simulation results, a new combined IR (infrared)/PIV (particle image velocimetry)/DIA (digital image analysis) measuring technique has been recently developed in the group. A high resolution IR camera and a high speed visual camera are combined together to get the visual image of particles positions and the temperature distribution simultaneously (shown as the images below).

DISSERTATIONS

-

SCIENTIFIC PUBLICATIONS

1. Z. Li, M. van Sint Annaland, J.A.M. Kuipers, N.G. Deen, Effect of superficial gas velocity on the particle temperature distribution in a fluidized bed with heat production, Chem. Eng. Sci. 140 (2016) 279–290.

Illustration of the set-up with two cameras: the X8400SC FLIR IR camera, resolution 1280×1024 pixels(left); and LaVision ImagerPro, resolution 560×1280 pixels (right).

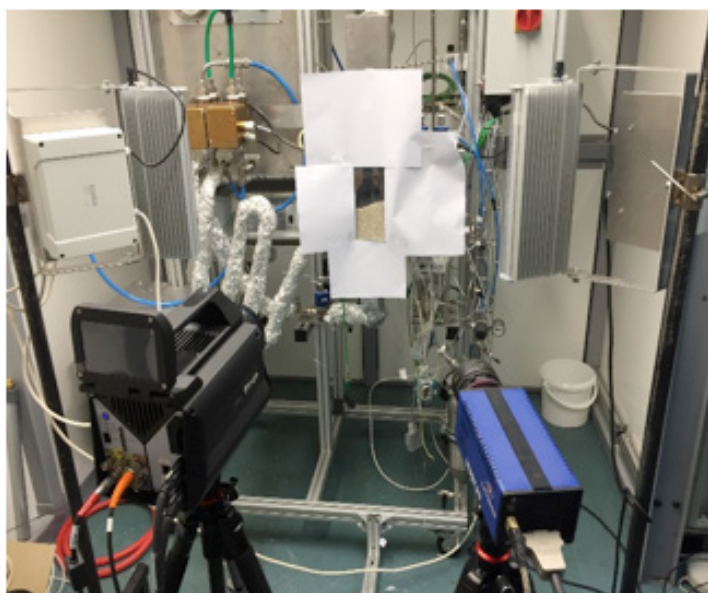

DIRECT NUMERICAL SIMULATION OF MASS AND HEAT TRANSFER WITH CHEMICAL REACTION IN DENSE BUBBLY FLOWS

PROJECT AIM

In this project we propose to utilize Direct Numerical Simulation (DNS) techniques (i.e. Front Tracking (FT) combined with Immersed Boundary Techniques) to study and quantify the exchange of mass and heat in dense bubbly flows. Particular problem of interest is to resolve the concentration and temperature boundary layers which are of orders of magnitudes smaller than the hydrodynamic boundary layers. The in house DNS codes will be extended with species conservation equations and thermal energy equations to study respectively mass transfer and heat transfer (to immersed surfaces) at the micro scale. One of the systems that will be studied involves a high liquid density and a high surface tension, which is of particular interest to the field of bubbly flow in liquid metals. Traditionally such flows are studied by using water as a model fluid. However, apart from the temperature and pressure effects, liquid metals substantially differ from water in their wettability to ceramics, their density and surface tension. The DNS tools will enable us to investigate the behavioral differences between liquid metal and water. We will also consider cases with (predefined) bubble size distributions, starting from mono-disperse and bi-disperse systems.

PROGRESS

The project has been recently started in September 2015. A detailed literature survey about front tracking and ways to resolve multiscale transport phenomena has been presented and discussed. Current ongoing work includes way to couple the hydrodynamics solver which uses front tracking with convection diffusion equation on an adaptive grid which localizes the computational effort in areas of high gradient/error.

DISSERTATIONS

-

SCIENTIFIC PUBLICATIONS

-

PROJECTLEADERS

JAM Kuipers

RESEARCHTHEME

Mathematical and computational methods for fluid flow analysis

PARTICIPANTS

IA Panda, EAJF Peters, JAM Kuipers

COOPERATIONS

-

FUNDED

FOM, Akzo Nobel, DSM, Sabic Shell and Tata Steel

University	-
FOM	50 %
STW	-
NWO Other	-
Industry	50 %
TNO	-
GTI	-
EU	-
Scholarships	-

START OF THE PROJECT

2015

INFORMATION

A Panda
06 85081920
a.panda@tue.nl

DIRECT NUMERICAL SIMULATION OF PHASE TRANSITION IN DENSE BUBBLY FLOWS

PROJECT LEADERS

JAM Kuipers

RESEARCH THEME

Mathematical and computational methods for fluid flow analysis

PARTICIPANTS

H Mirsandi, EAJF Peters,

JAM Kuipers

COOPERATIONS

-

FUNDED

FOM, Akzo Nobel, DSM, Sabic, Shell and Tata Steel

NWO

University -

FOM 50 %

STW -

NWO Other -

Industry 50 %

TNO -

GTI -

EU -

Scholarships -

START OF THE PROJECT

2015

INFORMATION

H Mirsandi

06 12357452

h.mirsandi@tue.nl

PROJECT AIM

In many practical applications phase transition (evaporation and boiling) in dense bubbly flows occur. This phenomenon is very complex because of the interplay between flow and coupled mass and heat transport. In this project we will develop and employ Direct Numerical Simulation (DNS) technique to study dense bubbly flows with phase transition. Initially, we will focus on phase transition in single component systems but multi-component systems will be studied as well. The DNS code will be extended with multi-component transport equations and thermal energy equations to study respectively mass transfer and heat transfer at the micro scale.

PROGRESS

The project has been recently started in November, 2015. Currently, interface reconstruction procedure that can automatically and robustly model topology changes, such as interface breakup and merging, are being implemented into Front Tracking technique.

DISSERTATIONS

-

SCIENTIFIC PUBLICATIONS

-

MULTISCALE MODELLING OF DENSE GAS-FLUIDIZED FLOWS OF NON-SPHERICAL PARTICLES: BULK DPM

PROJECT AIM

This project is a part of the Multiscale modelling of dense gas-fluidized flows of non-spherical particles project. This sub-project focuses on in bulk effects and particle size aspect ratio. It's aim is to develop a functional Discrete Particle Model for simulation of dense gas-solid flows of inelastic non-spherical particles and validate it with in-house Magnetic Particle Tracking experiments. This model will subsequently be used to obtain particle stress correlations for a more coarse-grained multi-particle collision model.

PROGRESS

A literature overview of discrete particle models (DPM) has been made and OpenFOAM software has been adapted to include rodlike particles.

DISSERTATIONS

-

SCIENTIFIC PUBLICATIONS

-

PROJECT LEADERS

JT Padding

RESEARCH THEME

Complex dynamics of fluids

PARTICIPANTS

I Mema, JT Padding, B Fitzgerald, JAM Kuipers

COOPERATIONS

-

FUNDED

European Research Council (ERC)

University -

FOM -

STW -

NWO Other -

Industry -

TNO -

GTI -

EU 100 %

Scholarships -

START OF THE PROJECT

2015

INFORMATION

I Mema

I.Mema@tue.nl

CLINGCO2: CHEMICAL LOOPING REFORMING FOR PURE HYDROGEN PRODUCTION WITH INTEGRATED CO₂ CAPTURE

PROJECT LEADERS

F Gallucci, M van Sint Annaland

RESEARCH THEME

Complex dynamics of fluids

PARTICIPANTS

JA Medrano Jiménez, R Voncken,
V Spallina

COOPERATIONS

-

FUNDED

STW

University -

FOM -

STW 100 %

NWO Other -

Industry -

TNO -

GTI -

EU -

Scholarships -

START OF THE PROJECT

2013

INFORMATION

JA Medrano Jiménez

040 247 8055

06 42 055 727

j.a.medrano.jimenez@tue.nl

PROJECT AIM

A Chemical Looping reactor concept for CO₂ capture with immersed Pd-membranes for hydrogen separation using CH₄ as fuel is proposed in this project. The development of the project combines deep investigation on thermodynamics, hydrodynamics of the reactor, mass transfer measurements and selection of the catalyst for the process. All these measurements will help in the optimization of the reactor and its scale-up to lab scale demonstration. A phenomenological model able to describe the behaviour of the concept will be also developed during the project. Finally, a techno-economical analysis will be carried out to demonstrate the applicability at larger scales.

PROGRESS

During the last year different novel Pd-based metallic supported membranes have been studied and it has been found that they are able to withstand high temperatures with outstanding selectivities for H₂ separation. Furthermore, fundamental aspects on the hydrodynamics of a circulating fluid bed (representing the chemical looping system) have been investigated, where two novel methods for an accurate measurement of solids circulation rates have been developed and will be subsequently used in the lab scale demonstration setup. In addition, an experimental technique based on infra-red digital image analysis has been further extended to enable mass transfer studies in fluidized beds with the aim to develop improved closure correlations. This novel technique also allows the combination of mass transfer and hydrodynamics at once. Finally, this information has been implemented in a novel phenomenological model to describe the proposed reactor.

DISSERTATIONS

-

SCIENTIFIC PUBLICATIONS

1. J.A. Medrano et al, Applied Energy, 158 (2015), 86-96.
2. J.A. Medrano et al, Chemical Engineering Journal, 282 (2015), 45-57.
3. J.A. Medrano et al, International Journal of Hydrogen Energy (2015), <http://dx.doi.org/10.1016/j.ijhydene.2015.10.094>.
4. E. Fernandez et al, Chemical Engineering Journal (2015), <http://dx.doi.org/10.1016/j.ccej.2015.09.119>.

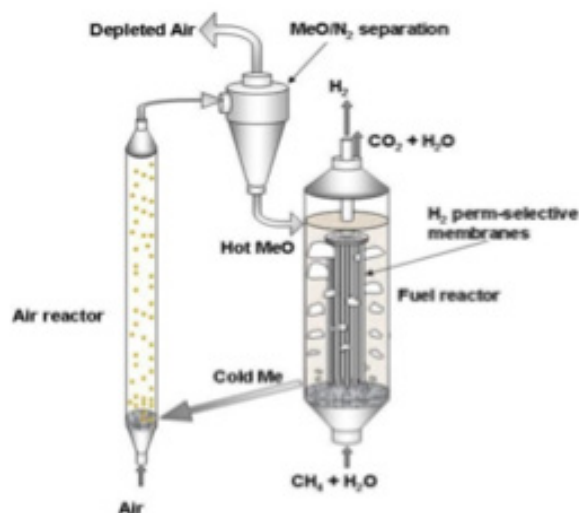

Schematic description of the reactor concept developed in this project

SIMULATION OF PROPPANT TRANSPORT FOR SHALE GAS PRODUCTION

PROJECT AIM

In shale formations the gas-permeability is increased by injecting complex particle-filled liquids (fracking). The so-called proppant particles prevent the fractures from fully closing when the flow of liquid is stopped. In order to predict where the particles deposit in a network of fractures we need to know how proppant is transported in a network of fractures. This research is aimed at modeling the particle transport on the relevant length scales. Three scales of coarse-grained computational multiphase fluid modeling will be used to analyse the sedimentation of particles. At all these scales, we will consider the behavior of sedimenting proppant particles at higher Reynolds number and/or in a viscoelastic medium. The creation of porous beds, also for polydisperse mixtures of grain-sizes, and the distribution of proppant in a network of fractures will be investigated.

PROGRESS

To understand the proppant transport at various flow conditions in rock fractures, 3D CFD model is developed. Sharp-interface ghost cell immersed boundary method (IBM) is implemented to account for the fluid-solid interaction. Moreover, there will be an interaction between solid-solid particles as well and this is accounted through the use of discrete element model (DEM) consisting of lubrication model and the collision model. The combined immersed boundary – discrete element model (IB-DEM) model is used for direct numerical simulation (DNS) of particle-laden flows and to improve the understanding of the transport phenomenon of proppants. The developed code is validated for single and multiple particle system at varying Reynolds number. The sample figure of two-particle sedimentation case is presented. This is also called as drafting-kissing-tumbling case, defining the stages during sedimentation.

DISSERTATIONS

-

SCIENTIFIC PUBLICATIONS

-

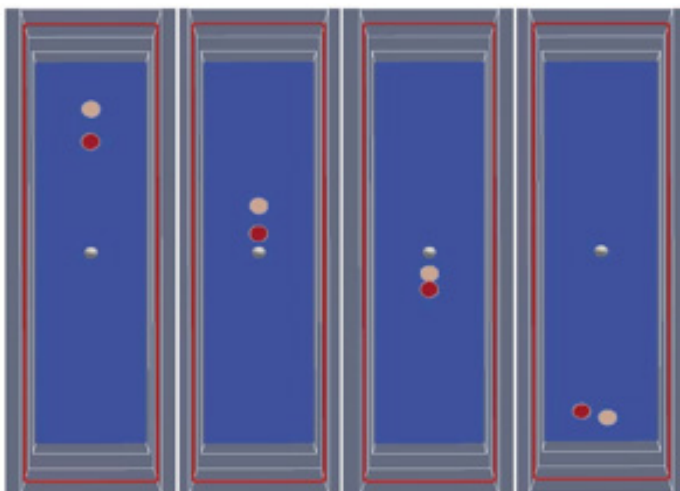

PROJECT LEADERS

EAJF Peters, JT Padding

RESEARCH THEME

Mathematical and computational methods for fluid flow analysis

PARTICIPANTS

R Maitri, EAJF Peters, JT Padding, JAM Kuipers

COOPERATIONS

Dr. Johan Romate- SHELL

FUNDED

FOM, Shell	
University	-
FOM	50 %
STW	-
NWO Other	-
Industry	50 %
TNO	-
GTI	-
EU	-
Scholarships	-

START OF THE PROJECT

2014

INFORMATION

R Maitri
040 247 4487
r.maitri@tue.nl

MULTISCALE MODELLING OF DENSE GAS-FLUIDIZED FLOWS OF NON-SPHERICAL PARTICLES: HYDRODYNAMIC FORCES

PROJECT LEADERS

JT Padding

RESEARCH THEME

Mathematical and computational methods for fluid flow analysis

PARTICIPANTS

SKP Sanjeevi, JT Padding,

JAM Kuipers

COOPERATIONS

-

FUNDED

European Research Council (ERC)

University -

FOM -

STW -

NWO Other -

Industry -

TNO -

GTI -

EU 100 %

Scholarships -

START OF THE PROJECT

2014

INFORMATION

SK Pacha Sanjeevi

040 247 8783

s.k.pacha.sanjeevi@tue.nl

PROJECT AIM

The objective is to pioneer a novel multiscale simulation methodology for dense gas-solid flows of non-spherical particles, based on systematic coarse-graining of interactions from small to larger scales, backed up by validating in-house experiments. As a first step, fully resolved direct numerical simulations (DNS) are to be performed to obtain the drag, lift and torque closures of suspensions containing elongated particles. Such particles are relatively simple, yet many of the fundamental problems linked to anisotropic drag and collisions already appear. The closures would later be used to perform discrete particle model simulations, which are in-turn validated with experiments.

PROGRESS

Currently, detailed investigations of different non-spherical particles are investigated in single particle configuration. Drag, lift and torque coefficients for such particles are calculated at different Reynolds number and different angles of attack with respect to the incoming flow. The results are compiled to produce necessary drag, lift and torque correlations for such particles.

DISSERTATIONS

-

SCIENTIFIC PUBLICATIONS

1. S.K.P. Sanjeevi, J.T. Padding, J.A.M. Kuipers (2015). Direct numerical simulations of fluid drag forces of non-spherical particle. The 11th International Conference on CFD in the Minerals and Process Industries, Melbourne, Australia, 7-9 December, 2015.

MULTISCALE MODELLING OF FLUIDIZED NON-SPHERICAL PARTICLES : WALL PROXIMITY EFFECTS

PROJECT AIM

The project aims at a full understanding of the hydrodynamics of fluidized beds containing non spherical (rod-like) particles. The main task of this project is to implement a DPM code for rod-like particles, incorporate new drag relations for translational and rotational hydrodynamic forces (obtained from DNS simulations), and to validate these closures using PIV/DIA measurements in quasi-2D fluidized beds. Novel concepts will be the inclusion of wall proximity effects (e.g. lift forces and particle orientation effects) for non-spherical particles and the detection of particle orientation and angular velocity using PIV/DIA.

PROGRESS

In the last year, new strategy of exact analytical calculation for DPM modelling of non-spherical (spherocylindrical) particles was implemented in DPM open-source code LIGGGHTS. Coupling with flowsolver (Openfoam) was also established using the existing open-source CFDEMCoupling framework. The developed code will now be tested with packed bed simulations, against predictions of standard Ergun equation for pressure drop across the bed. Experiments for fluidized bed of these particles are planned in the coming year.

DISSERTATIONS

-

SCIENTIFIC PUBLICATIONS

-

PROJECTLEADERS

JT Padding

RESEARCHTHEME

Mathematical and computational methods for fluid flow analysis

PARTICIPANTS

VV Mahajan, JT Padding,
B Fitzgerald, JAM Kuipers

COOPERATIONS

-

FUNDED

European Research Council (ERC)

University -

FOM -

STW -

NWO Other -

Industry -

TNO -

GTI -

EU 100 %

Scholarships -

START OF THE PROJECT

2014

INFORMATION

V Mahajan

040 247 3295

v.v.mahajan@tue.nl

A snapshot of packed bed of 8000 spherocylindrical particles simulated using the newly developed DPM code

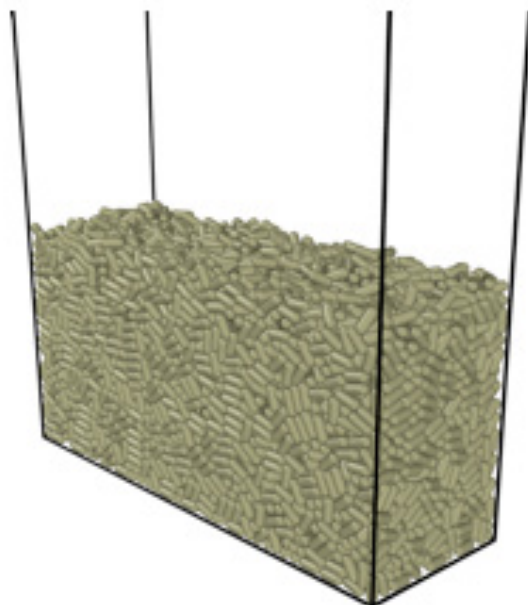

MC-DNS STUDY OF MASS TRANSFER WITH CATALYTIC SURFACE REACTION

PROJECT LEADERS

JAM Kuipers

RESEARCH THEME

Complex dynamics of fluids

PARTICIPANTS

J Lu, EAJF Peters, RE Bulo,
RA van Santen, JAM Kuipers

COOPERATIONS

University Utrecht

FUNDED

Netherlands Center for Multiscale
Catalytic Energy Conversion (MCEC)

University	-
FOM	-
STW	-
NWO Other	100 %
Industry	-
TNO	-
GTI	-
EU	-
Scholarships	-

START OF THE PROJECT

2014

INFORMATION

J Lu
040 247 8868
j.lu1@tue.nl

PROJECT AIM

Quantitatively model the mass transport chain for realistic processes with multicomponent reactant and product mixtures, polydisperse particles and catalytic reaction kinetics. With this full synthesized model, it is expected to give prediction of the performance of an industrial catalytic conversion process by computer simulation, which will give insight in the interplay of transport and reactivity, and therefore real chemical processes can be optimized.

PROGRESS

Implementation of 3D mass transport equation to describe the flow of species around catalytic particles. Implementation of directional quadratic interpolation scheme for the Immersed boundary method. Implementation of quadratic interpolation scheme for the Immersed boundary method. Realization of above mentioned two schemes in fluid-solid interface for sphere and pipe cases.

DISSERTATIONS

-

SCIENTIFIC PUBLICATIONS

-

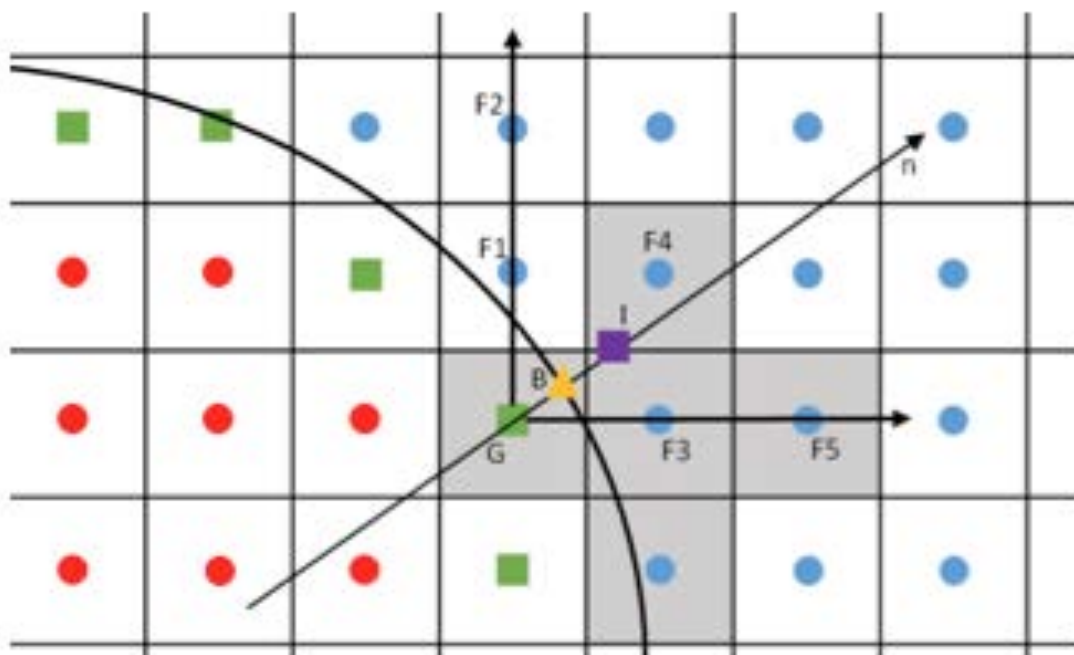

FLOW MRI IN PACKED AND FLUIDIZED BEDS

PROJECT AIM

In most chemical processes flow systems are multiphase flows and not transparent. We use MRI to visualize the flow, which we cannot see with optical (camera) techniques, and obtain quantitative data in cases where processes taking place in the interior remain obscure, which is often a major limitation. Experimental results are needed to validate complex computational models, developed to simulate the flow in multiphase systems of industrial relevance, like packed and fluidized beds.

PROGRESS

An experimental setup, to study structure and hydrodynamics in a packed bed of spherical particles by means of MRI, was built and used to determine phase fractions and the axial velocity of water. Phase fractions were evaluated by processing 3-D datasets of the packed bed, obtained with MRI, while the axial velocity of water, flowing through the bed, was acquired by directly encoding velocity values with a method suitable for Flow MRI studies. Results for a slice are shown in Fig. 1. CFD simulations of the experimental system were performed using a DEM code to generate the packing of spherical particles and an in-house IBM-DNS code to evaluate porosity and flow inside the bed.

DISSERTATIONS

-

SCIENTIFIC PUBLICATIONS

-

PROJECT LEADERS

JAM Kuipers

RESEARCH THEME

Complex dynamics of fluids

PARTICIPANTS

P Lovreglio, EAJF Peters, L Pel, JAM Kuipers

COOPERATIONS

-

FUNDED

Netherlands Center for Catalytic Energy, Conversion (MCEC)

University	-
FOM	-
STW	-
NWO Other	100 %
Industry	-
TNO	-
GTI	-
EU	-
Scholarships	-

START OF THE PROJECT

2014

INFORMATION

P Lovreglio
040 247 8871
p.lovreglio@tue.nl

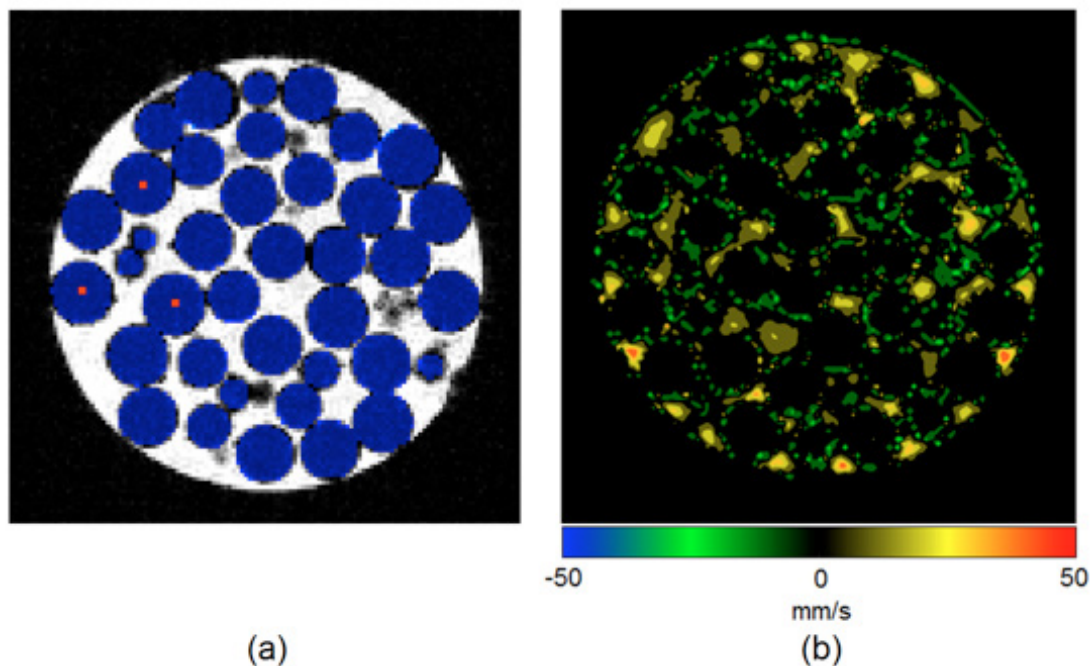

Experimental phase fractions (a) and axial velocity of water (b) for a slice obtained by means of MRI applied to a packed bed of spherical particles.

DIRECT NUMERICAL SIMULATION (DNS) OF TRANSPORT AND CHEMICAL REACTION IN THREE-PHASE FLOWS

PROJECT LEADERS

JAM Kuipers

RESEARCH THEME

Mathematical and computational methods for fluid flow analysis

PARTICIPANTS

S Islam, EAJF Peters, JAM Kuipers

COOPERATIONS

-

FUNDED

NWO-CW

University -

FOM -

STW -

NWO Other 100 %

Industry -

TNO -

GTI -

EU -

Scholarships -

START OF THE PROJECT

2014

INFORMATION

Md. Shafiqul Islam

040 247 8870

M.S.Islam@tue.nl

PROJECT AIM

In the past decades, many researchers have predicted the behavior of mass transfer gas-liquid-solid using fixed grid approaches. As the mass boundary layer is very thin compared to the momentum boundary layer, fixed grid approaches require fine grids, which makes the computation very expensive. To overcome this issue, we follow the technique of mass boundary layer method embedded in front tracking model to simulate the mass transfer of bubble. Due to the coupling of mass boundary layer method with a front tracking method, the computation becomes feasible.

PROGRESS

In our present work, we implemented the mass boundary layer method by considering creeping flow and potential flow of a rising spherical bubble. Although the implementation of mass boundary layer method is quite arduous, it doesn't suffer from the inadequate expenditure of the computation. For proper verification of mass transfer, Sherwood number (Sh) with respect to different values of the Peclet (Pe) and Reynolds number (Re) are compared with analytical solution, both for creeping flow and potential flow. Eventually, the transferred mass and received mass from bubble side and flow domain are also verified in well manner.

DISSERTATIONS

-

SCIENTIFIC PUBLICATIONS

-

MULTISCALE EXPERIMENTS AND SIMULATIONS OF AGGLOMERATION IN SPRAY DRIERS

PROJECT AIM

The main goal of the project is: to provide Tetra Pak with experimentally validated predictive computational tools that can be used to tailor spray drier operations. The first part of the project is based on the investigation of viscous effect on droplet interactions. Binary droplet collisions are analyzed numerically through DNS and experimentally through droplet generator device. The obtained results will be used to develop theoretical model for the description of collision outcomes boundaries.

PROGRESS

The DNS VOF in-house code has been modified in order to perform binary droplet collisions for different impact parameters and We numbers. The purpose is to obtain a regime map with the different collision outcomes (example of separation in Fig.1 (a)). The viscous dissipation energy has been implemented in order to track its evolution during collision phenomenon for different conditions (example of dissipation energy rate [J/s] trend during collision event in Fig.1 (b)). The experimental set up has been designed and developed. A support structure for the precise regulation of relative nozzles positions has been built. The phenomenological models for the collision outcomes have been developed with the inclusion of energy dissipation in the energy balances. The models have been compared with numerical results and will be validated by experiments. This investigation, based on the micro scale, will be used to find a closure for the macro scale model on a spray.

DISSERTATIONS

-

SCIENTIFIC PUBLICATIONS

1. AN EXPERIMENTAL STUDY OF DROPLET-PARTICLE COLLISIONS, G. Finotello, S. K. Pawar, F. Henrikson, J. T. Padding, N. G. Deen, A. Jongsma, F. Innings, J.A.M. (Hans) Kuipers, 7th International Granulation Workshop, The University of Sheffield, UK, 1st-3rd July 2015.
2. STUDY OF THE EFFECT OF VISCOSITY ON BINARY DROPLET, G. Finotello, J. T. Padding, N. G. Deen, A. Jongsma, F. Innings, J.A.M. (Hans) Kuipers, 14TH Workshop on Two-Phase Flow Predictions, Halle(Saale), Germany, 7th -10th September 2015.

PROJECT LEADERS

JAM Kuipers, JT Padding

RESEARCH THEME

Mathematical and computational methods for fluid flow analysis

PARTICIPANTS

G Finotello, JT Padding, JAM Kuipers

COOPERATIONS

Tetra Pak

FUNDED

Tetra Pak	
University	-
FOM	-
STW	-
NWO Other	-
Industry	100 %
TNO	-
GTI	-
EU	-
Scholarships	-

START OF THE PROJECT

2014

INFORMATION

G Finotello
040 247 2589
G.Finotello@tue.nl

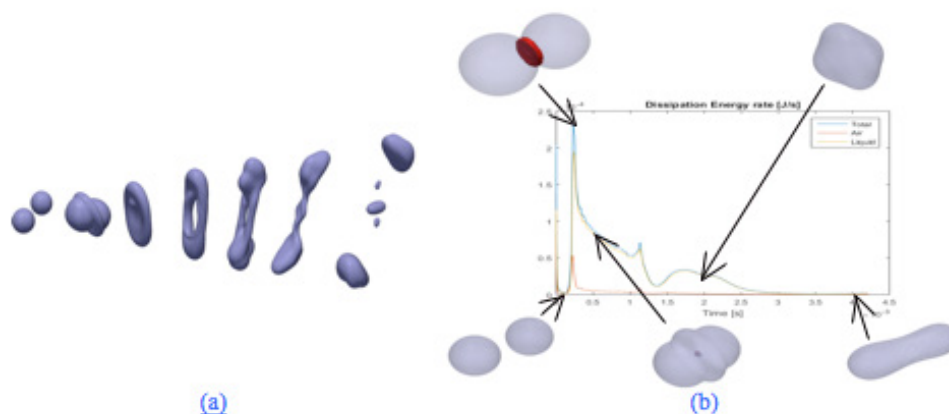

(a) example of separation (b) example of dissipation energy rate [J/s] during collision

VISCOELASTIC FLOW MODELLING FOR POLYMER FLOODING

PROJECT LEADERS

JT Padding, EAJF Peters

RESEARCH THEME

Mathematical and computational methods for fluid flow analysis

PARTICIPANTS

S De, JT Padding, EAJF Peters, JAM Kuipers

COOPERATIONS

Dr. Albert Janssen- SHELL, Dr. Cor van Kruijsdijk – SHELL

FUNDED

FOM, Shell	
University	-
FOM	50 %
STW	-
NWO Other	-
Industry	50 %
TNO	-
GTI	-
EU	-
Scholarships	-

START OF THE PROJECT

2013

INFORMATION

JT Padding
040 247 3674
j.t.padding@tue.nl

PROJECT AIM

Polymer liquids are used in the oil industry to improve the volumetric sweep and displacement efficiency of the oil from a reservoir. Surprisingly, it is not only the viscosity but also the elastic properties of the displacing fluid that determine the displacement efficiency. This may be caused by the ability of a viscoelastic fluid to pull oil out of dead-ends. The objective of the project is to develop a computer simulation methodology for the flow of non-Newtonian fluids through porous media. This will enable us to gain a fundamental understanding of the effects of fluid elasticity and interfacial tension between the oil phase and the displacing fluid on the recovery efficiencies.

PROGRESS

To understand the flow of polymers through a porous media and explain the viscoelastic effects a 3D Computational Fluid Dynamics (CFD) based code has been developed. Advanced Maxwell models (FENE-P, PTT Models) which can capture shear and extensional viscosity of polymer have been incorporated in the model. A second order IBM method has been implemented, to model the porous media. The validated coupled IBM viscoelastic model is used to model realistic porous media flow. The complex effect of rheology and fluid motion will be studied for different pore structures. Micro-PIV experiments are performed in a pillared microchannel to observe flow characteristics of viscoelastic fluid in a model porous media. Flow instabilities are observed at higher viscoelasticity. Currently two phase (oil and polymer) micro-piv experiments are performed in this set up to obtain insights of an actual enhanced oil recovery process.

DISSERTATIONS

-

SCIENTIFIC PUBLICATIONS

1. S. De, E.A.J.F. Peters, J.A.M. Kuipers, J.T. Padding, Viscoelastic Flow Modelling for Polymer Flooding. Conference Proceeding: AICHE Annual meeting, Salt lake city, USA, Nov 2015.
2. S. De, E.A.J.F. Peters, J.A.M. Kuipers, J.T. Padding, Viscoelastic Flow Modelling in Porous Media Conference Proceeding: American Physical Society – 68th Annual DFD Meeting, Boston, Nov 2015.
3. S. De, S.Das, E.A.J.F. Peters, J.A.M. Kuipers, J.T. Padding, A coupled finite volume immersed boundary method for simulating 3D viscoelastic flows in porous media, submitted to JNNFM, 2015.

3D Viscoelastic Flow streamlines through a periodic array of cylinders (Coloured with velocity)

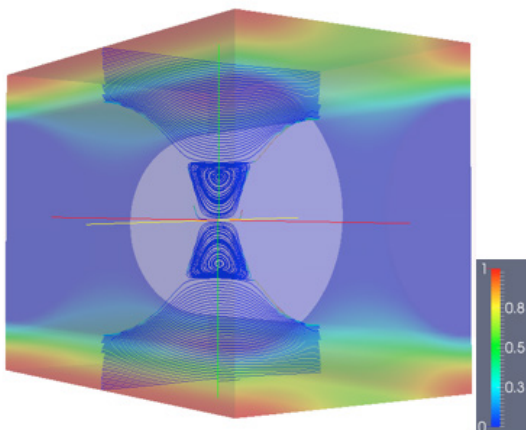

MULTI-SCALE MODELLING OF MASS, MOMENTUM AND HEAT TRANSFER IN ADSORPTION DRYERS

PROJECT AIM

The objectives of the proposed research is the development of a comprehensive software tool that enables the calculation of an adsorption dryer device that can be used for optimization of existing units and explore the feasibility for specific future customer needs. The validated model is expected to serve as a workhorse in should include all relevant physical phenomena of the process including mass, momentum and heat transfer prevailing at different time and length scales.

PROGRESS

A hierarchy of models (1D/2D/3D) have been built. A comparative study between 1D model and 3D model is carried out. The 1D and 3D model predictions are validated against literature experimental data for the example of water vapor adsorption and desorption operated in a cyclic counter-flow arrangement. The obvious heat and adsorbate concentration gradients observed in both radial and circumferential directions indicate that the detailed 3D model is indispensable. A systematical parametric study has been done based on the rigorous 3D model, in which the effects of thermal conductivity of adsorbent layer, specific heat, porosity, tortuosity, layer thickness and geometrical shape on the performance of moisture adsorption processes are investigated. The concomitant heat and mass transfer mechanisms in the investigated cases are thoroughly analysed taking advantage of the robust 3D model, which deepens our understanding on such non-linear complicated processes.

DISSERTATIONS

-

SCIENTIFIC PUBLICATIONS

1. Dang Cheng, E.A.J.F. Peters, J.A.M. Kuipers. Numerical modelling of flow and coupled mass and heat transfer in a rotary desiccant wheel, 11th International Conference on Computational Fluid Dynamics in the Minerals and Process Industries, Dec 7-9, 2015, MCEC, Melbourne, Australia.

PROJECT LEADERS

JAM Kuipers

RESEARCH THEME

Mathematical and computational methods for fluid flow analysis

PARTICIPANTS

D Cheng, E.A.J.F. Peters, JAM Kuipers

COOPERATIONS

-

FUNDED

University	-
FOM	-
STW	-
NWO Other	-
Industry	100 %
TNO	-
GTI	-
EU	-
Scholarships	-

START OF THE PROJECT

2014

INFORMATION

JAM Kuipers
040 247 4158
j.a.m.kuipers@tue.nl

MULTISCALE MODELING OF GAS-SOLID MASS TRANSFER AND ITS IMPACT ON RISER PERFORMANCE

PROJECT LEADERS

JAM Kuipers

RESEARCH THEME

Complex structures of fluids

PARTICIPANTS

A Carlos Varas, EAJF Peters,
JAM Kuipers

COOPERATIONS

-

FUNDED

NWO-CW
University -
FOM -
STW -
NWO Other 100 %
Industry -
TNO -
GTI -
EU -
Scholarships -

START OF THE PROJECT

2013

INFORMATION

A Carlos Varas
06 19804533
a.e.carlos.varas@tue.nl

PROJECT AIM

The objective of the project is to conduct a combined experimental and computational investigation on the impact of heterogeneity on riser reactor performance. A laboratory scale riser set up is used to characterize the hydrodynamics and particle-cluster formation using image-velocimetry combined with digital image analysis. Mass transfer characteristics are measured by using ozone decomposition by catalyst particles. CFD-DEM simulations are performed to validate the model, using the experimental data.

PROGRESS

A novel Digital Image Analysis (DIA) technique has been developed. This DIA technique, is insensitive to inhomogeneous lighting gradients and shadows, enabling full-field accurate measurements of solids volume fraction on a pseudo-2D riser reactor. DIA is combined with Particle Image Velocimetry to characterize riser hydrodynamics under diverse operational conditions. This combined experimental technique also enables detection of clustered regions and obtain a large amount of data related to cluster properties. These experiments have been employed to validate the reliability of a CFD-DEM. This model is found to predict satisfactorily riser hydrodynamics as well as clustering phenomena.

DISSERTATIONS

-

SCIENTIFIC PUBLICATIONS

1. A.C.Varas, E.A.J.F. Peters, N.G.Deen, and J.A.M. Kuipers. Numerical and experimental characterization of particle clusters in riser flow. Proceedings of the 11th International Conference on Computational Fluid Dynamics in the Minerals and Process Industries CSIRO, 7-9 December 2015, Melbourne Australia.
2. A.C.Varas, E.A.J.F. Peters, N. Deen, J.A.M. Kuipers. Computational and experimental study of cluster formation in riser flow. NWO's CHAINS 2015, the Dutch Chemistry Conference, 30 Nov-3 December, Eindhoven Netherlands.

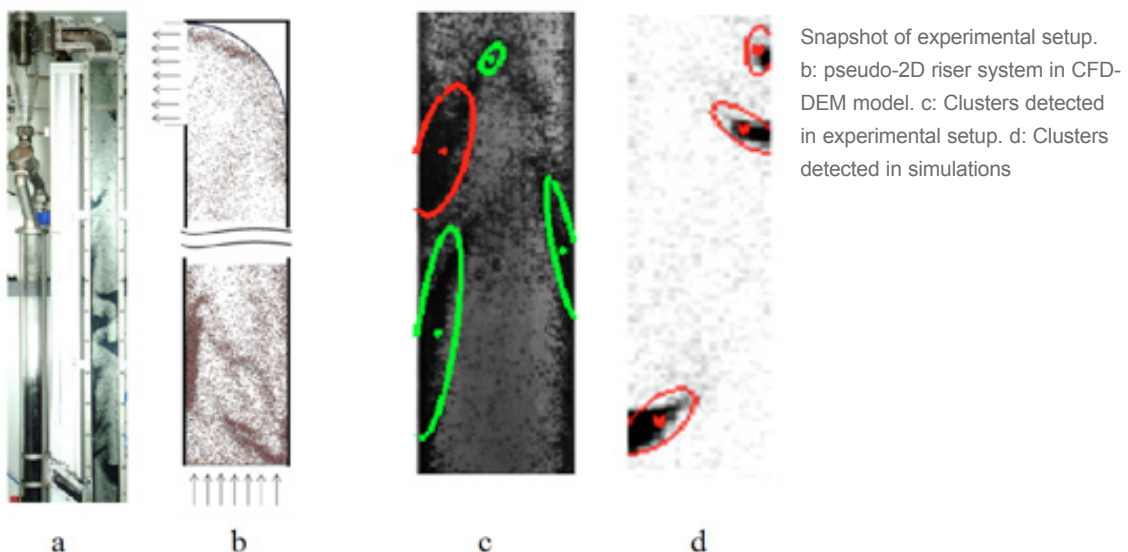

FLOW STRUCTURE FORMATION AND COUPLING WITH TURBULENCE IN LARGE SCALE SLURRY BUBBLE COLUMN

PROJECT AIM

Our aim is to obtain a better understanding of the hydrodynamics and heat- and mass-transfer limitations, and the role of turbulence in large scale slurry bubble columns using state-of-the-art computer simulations. We are concentrating on development of a high performance parallel code and new models and approaches to predict phase interactions and aim to achieve a detailed resolution of turbulent structures and prediction of the bubble dynamics by using Direct Simulation Monte Carlo (DSMC).

PROGRESS

The solution of 3d transient multiphase flow on large scales is computationally time consuming and demand, both in terms of CPU-time and memory requirements. The most significant part of numerical techniques we are using is a solving of a large sparse matrices. Thus, we were concentrating on development of a new high performance library of linear solvers. We have taken as a basis Krylov Subspace solvers (CG family) accelerated with Algebraic Multigrid method. The code has been tested on a large number of model problems and showed good performance and robustness in comparison with widely used ICCG method.

DISSERTATIONS

-

SCIENTIFIC PUBLICATIONS

-

PROJECTLEADERS

JT Padding, JAM Kuipers

RESEARCHTHEME

Mathematical and computational methods for fluid flow analysis

PARTICIPANTS

MV Masterov, JT Padding, JAM Kuipers

COOPERATIONS

-

FUNDED

Netherlands Center for Catalytic Energy Conversion (MCEC)

University -

FOM -

STW -

NWO Other 100 %

Industry -

TNO -

GTI -

EU -

Scholarships -

START OF THE PROJECT

2015

INFORMATION

MM Vadimovich

06 28299432

m.v.masterov@tue.nl

<http://padding.awardspace.info/>

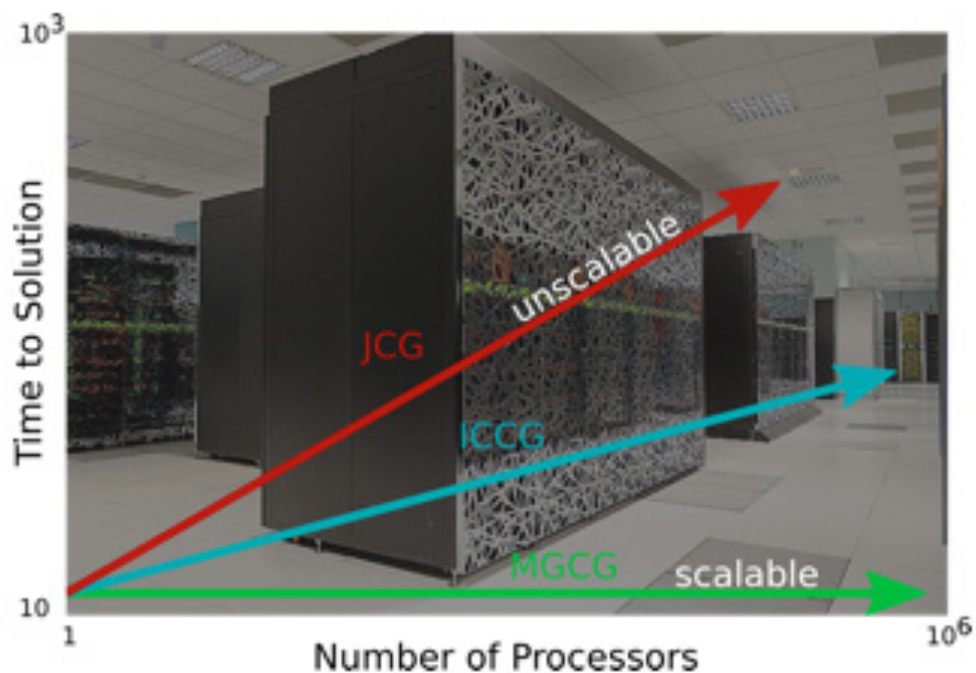

EXPERIMENTAL STUDY OF TRANSPORT AND CHEMICAL REACTION IN THREE-PHASE FLOWS

PROJECT LEADERS

JAM Kuipers

RESEARCH THEME

Mathematical and computational
methods for fluid flow analysis

PARTICIPANTS

G Kong, EAJF Peters, JAM Kuipers

COOPERATIONS

-

FUNDED

NWO-CW	
University	-
FOM	-
STW	-
NWO Other	100 %
Industry	-
TNO	-
GTI	-
EU	-
Scholarships	-

START OF THE PROJECT

2015

INFORMATION

G Kong
040 247 8199
g.kong@tue.nl

PROJECT AIM

Mass transfer and transport is immensely important in chemical engineering, but local measurement is extremely difficult in multiphase flow due to complicated optical issues, in this project dual LIF technique is employed and developed to overcome the problems.

PROGRESS

Dye and optical measuring system are carefully selected and integrated.

DISSERTATIONS

-

SCIENTIFIC PUBLICATIONS

-

SIMULATION OF LARGE SCALE GAS LIQUID SOLID FLOWS WITH STOCHASTIC EULER-LAGRANGIAN METHODS

PROJECT AIM

To develop model for large scale slurry bubble columns using stochastic Euler-Lagrangian methods. Deterministic methods like the discrete bubble model provide a detailed enough information on the type of flow and also track position of all bubbles at the same time. This rather becomes quite expensive considering collisions especially in the dense bubbly flow regime which is the situation in industrial slurry columns. On the other hand multi-fluid models do not resolve bubble interactions which makes the model susceptible to large errors.

PROGRESS

The project has recently started. Currently the stochastic model will be applied to a bubbly flow system will be compared with a deterministic model like discrete bubble model in terms of bubble-bubble interactions and encounters. This model will then be coupled with a more efficient (parallelized) flow solver for speed improvements.

DISSERTATIONS

-

SCIENTIFIC PUBLICATIONS

-

PROJECTLEADERS

JT Padding, JAM Kuipers

RESEARCHTHEME

Mathematical and computational methods for fluid flow analysis

PARTICIPANTS

SS Kamath, JT Padding, JAM Kuipers

COOPERATIONS

-

FUNDED

NWO-CW	
University	-
FOM	-
STW	-
NWO Other	100 %
Industry	-
TNO	-
GTI	-
EU	-
Scholarships	-

START OF THE PROJECT

2015

INFORMATION

S Kamath
06 42276507
s.s.kamath@tue.nl
j.t.padding@tue.nl

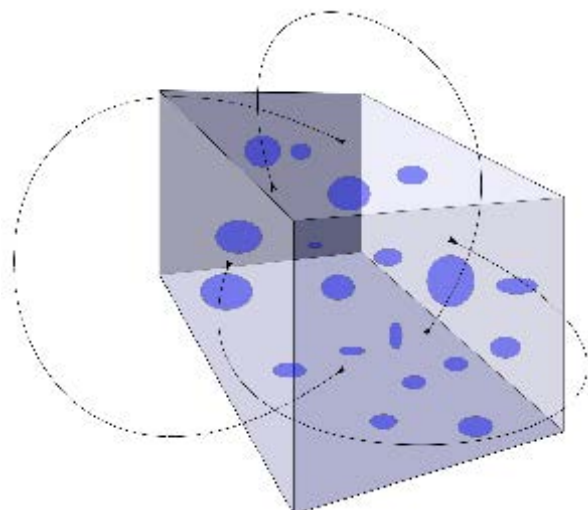

CHEMICAL LOOPING REFORMING FOR PURE HYDROGEN PRODUCTION WITH INTEGRATED CO₂ CAPTURE (CLINGCO₂)

PROJECT LEADERS

F Gallucci, I Roghair, M van Sint Annaland

RESEARCH THEME

Mathematical and computational methods for fluid flow analysis

PARTICIPANTS

RJW Voncken, JA Medrano Jimenez

COOPERATIONS

STW, Sintef, Tecnalia, Shell, ECN, Air Products, Hygear

FUNDED

STW	
University	-
FOM	-
STW	100 %
NWO Other	-
Industry	-
TNO	-
GTI	-
EU	-
Scholarships	-

START OF THE PROJECT

2013

INFORMATION

RJW Voncken
040 247 8180
r.j.w.voncken@tue.nl

PROJECT AIM

The project aims to develop a novel reactor concept for the production of ultra-pure hydrogen with integrated CO₂ capture. The reactor concept is based on overall auto-thermal reforming of methane in a fluidized bed reactor where immersed hydrogen perm-selective membranes are used to extract and simultaneously purify the hydrogen whilst driving the equilibria towards the desired hydrogen product and where the energy and oxygen necessary for the reforming is provided via chemical looping. The following sub-goals were set:

- Quantifying the hydrodynamics and mass transfer phenomena in fluidized bed reactors containing hydrogen perm-selective membranes in various configurations
- Quantifying the effect of net gas production via steam methane reforming on the performance of fluidized bed membrane reactor systems.
- Understanding and describing the effects of solids circulation in systems with an interconnected fluidized bed and riser.
- Performing a scale-up and parametric study of fluidized bed membrane reactor systems.

PROGRESS

Hydrogen concentration profiles in gas-solid fluidized bed membrane reactors have been quantified by performing Two Fluid Model (TFM) simulations. Both vertically and horizontally immersed hydrogen perm-selective membranes have been investigated. The vertical membranes clearly suffer from concentration polarization, which reduces the hydrogen flux and thus the effectiveness of the system. Horizontally immersed membranes affect both the hydrodynamics and the mass transfer phenomena of the system, see Figure 1. Particularly the membranes near the walls suffer from reduced hydrogen concentrations, because the down flow of solids near the walls causes densified zones on top of the membranes. Below the membranes, gas pockets (non-rising gas bubbles devoid of particles) prevail, which may affect the mass transfer towards the membranes. These results will subsequently be used to improve phenomenological models for fluidized bed membrane reactors.

DISSERTATIONS

-

SCIENTIFIC PUBLICATIONS

1. J.A. Medrano, R.J.W. Voncken, I. Roghair, F. Gallucci and M. van Sint Annaland (2015). On the effect of gas pockets surrounding membranes in fluidized bed membrane reactors: An experimental and numerical study. Chem. Eng. J. 282:45-57.

Time-averaged hydrogen mole fraction and solids hold-up in a fluidized bed with horizontally immersed membranes in in-line configuration.

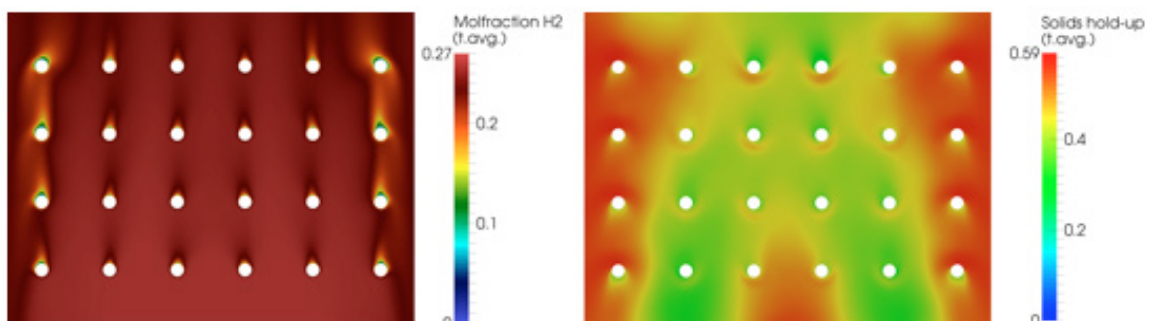

SCALE-UP AND INTENSIFICATION OF GRANULAR PROCESSES

PROJECT AIM

This project is part of European project Intensified-by-Design (IbD®). IbD will create a holistic platform for facilitating process intensification design and optimisation in processes in which solids are an intrinsic part. It will develop and upgrade methods for the handling of solids by intensification of currently existing processes, or through completely new approaches to the processing of solids. To support the design of intensified processes for solids handling, phenomenological models are developed making use of more fundamental simulations such as CFD and DEM models. The focus of this project lies on the development of predictive models for fluidized bed membrane reactors.

PROGRESS

Literature overview of different models and intensification possibilities for solids handling.

DISSERTATIONS

-

SCIENTIFIC PUBLICATIONS

-

PROJECT LEADERS

M Van Sint Annaland, I Roghair

RESEARCH THEME

Complex dynamics of fluids

PARTICIPANTS

M Mihajlović

COOPERATIONS

-

FUNDED

European Union

University -

FOM -

STW -

NWO Other -

Industry -

TNO -

GTI -

EU 100 %

Scholarships -

START OF THE PROJECT

2015

INFORMATION

M Mihajlović

m.mihajlovic1@tue.nl

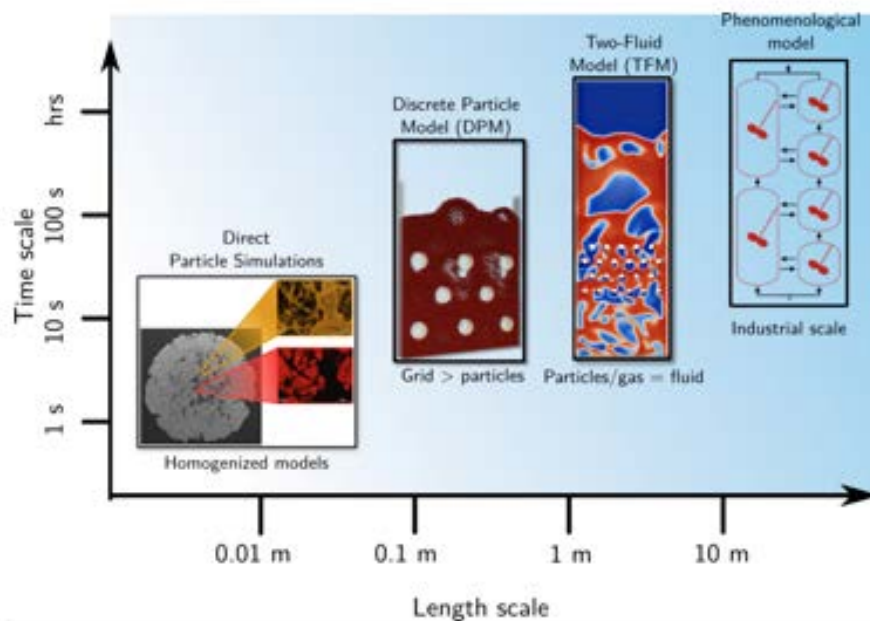

HEAT, MASS TRANSPORT AND PHASE TRANSITION IN DENSE BUBBLY FLOWS

PROJECT LEADERS

M Van Sint Annaland, I Roghair

RESEARCH THEME

Complex dynamics of fluids

PARTICIPANTS

A Battistella

COOPERATIONS

Delft University of Technology

University of Twente

FUNDED

FOM (IPP), AkzoNobel, DSM, Sabic,

Shell, Tata Steel

University -

FOM 50 %

STW -

NWO Other -

Industry 50 %

TNO -

GTI -

EU -

Scholarships -

START OF THE PROJECT

2015

INFORMATION

A Battistella

040 247 2277

a.battistella@tue.nl

PROJECT AIM

The main objective of this project is to provide further insight into the interplay between the various mechanisms in bubbly flows involving mass and heat transport, phase transitions and chemical reactions at larger scales. To achieve this goal, we will use an Euler-Lagrange (E-L) and Euler-Euler (E-E) approach to study large scale systems, incorporating closure information developed with DNS in other projects. Experimental validation will be carried out using experimental results from other projects for mass and heat transfer. Finally also scaling laws will be investigated for dense bubbly flows involving mass & heat transport, chemical reactions and phase transitions, including a link to phenomenological models for dispersed gas liquid multiphase flows.

PROGRESS

An Euler-Lagrange model was set up for basic simulations of bubbly flows including mass transfer.

DISSERTATIONS

-

SCIENTIFIC PUBLICATIONS

-

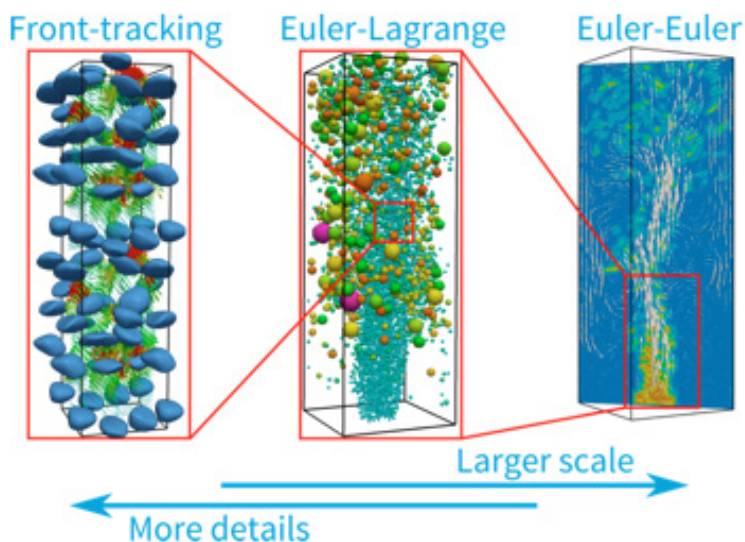

Simulation of Heat & Mass Transport and Phase Transitions in Dense Bubbly Flows at Intermediate and Large Scale

TRANSPORT PHENOMENA AND CHEMICAL REACTION IN SLENDER BUBBLE COLUMNS WITH OPEN-STRUCTURE RANDOM PACKING

PROJECT AIM

The objective is to obtain quantitative data and theoretical insights in the hydrodynamics and transport phenomena in a slender bubble column reactor filled with an open structure random packing (OSRP) through numerical simulation. A combined VOF-IBM (Volume Of Fluid and Immersed Boundary Method) based CFD code is developed, tested and rewritten for HPC (High Performance Computing) environment to obtain results in a realistic time-frame. Numerical results will be compared with experimental findings.

PROGRESS

A parallel IBM code including Conjugate Heat Transfer model has been developed.

DISSERTATIONS

-

SCIENTIFIC PUBLICATIONS

-

PROJECTLEADERS

JAM Kuipers, NG Deen

RESEARCHTHEME

Complex dynamics of fluids

PARTICIPANTS

S Das, NG Deen, JAM Kuipers

COOPERATIONS

-

FUNDED

University	-
FOM	-
STW	-
NWO Other	-
Industry	100 %
TNO	-
GTI	-
EU	-
Scholarships	-

START OF THE PROJECT

2013

INFORMATION

S Das
040 247 8182
s.das@tue.nl

NOVEL EXPERIMENTAL TECHNIQUES FOR DENSE GRANULAR FLOW

PROJECT LEADERS

JAM Kuipers

RESEARCH THEME

Complex dynamics of fluids

PARTICIPANTS

KA Buist, NG Deen, JAM Kuipers

COOPERATIONS

-

FUNDED

European Research Council (ERC)

University -

FOM -

STW -

NWO Other -

Industry -

TNO -

GTI -

EU 100 %

Scholarships -

START OF THE PROJECT

2012

INFORMATION

KA Buist

040 247 8021

K.A.Buist@tue.nl

www.tue.nl

PROJECT AIM

The primary objective of this study is to develop new experimental techniques to study particle-fluid interactions (heat transfer). The second goal is to use these techniques to complement and validate the knowledge gained with the multi-scale modelling approach.

PROGRESS

Last year has been spent to further develop a new particle tracking technique, called Magnetic Particle Tracking. The first findings have been written down and published in AIChE journal. Experiments have been performed to study the rotation of particles in a fluidized bed, the findings have been compared to discrete particle simulations. The results of this are currently written down and will be submitted to AIChE. Second a novel setup has been developed and tested to study heat transfer in semi-structured arrays, we are currently in the progress of finalizing our experiments and comparison to direct numerical simulations.

DISSERTATIONS

-

SCIENTIFIC PUBLICATIONS

1. Buist, K.A., Gaag, A.C. van der, Deen, N.G. & Kuipers, J.A.M. (2014). Improved magnetic particle tracking technique in dense gas fluidized beds. AIChE Journal : Chemical Engineering Research and Development, 60(9), 3133-3142.
2. Buist, K.A., Erdewijk, T.W. van, Deen, N.G. & Kuipers, J.A.M. (2015). Determination and comparison of rotational velocity in a pseudo 2D fluidized bed using Magnetic Particle Tracking and Discrete Particle Modelling. AIChE Journal : Chemical Engineering Research and Development, 61(10), 3198-3207.
3. Buist, K.A., Backx, B.J.G.H., Deen, N.G. & Kuipers, J.A.M. (2016). A combined experimental and simulation study of fluid-particle heat transfer in dense arrays of stationary particles. Submitted to Chemical Engineering Science.

BUBBLES ON THE CUTTING EDGE: EXPERIMENTAL INVESTIGATION ON MICRO-STRUCTURED BUBBLE COLUMNS

PROJECT AIM

The aim of the project is to construct a laboratory scale micro-structured bubble column reactor with a wire mesh to demonstrate proof of principle. The impact of wire mesh on bubble cutting, hydrodynamics characteristics is to be studied in-depth experimentally using advanced measurement techniques such as Particle image velocimetry and X-ray tomography. X-ray tomography experiments are done in co-operation with HZDR, Dresden, Germany. The performance of the wire mesh is compared with Sulzer packing used in the industry.

PROGRESS

Experiments were done in micro-structured square bubble column using fast X-ray tomography for various superficial gas and liquid velocities. Dual plane measurements were done for five heights in the column to obtain insight into the overall hydrodynamics of a micro-structured bubble column. This is used to obtain information on bubble size distribution and velocity in the square bubble column. Experiments were also done to study the effect of wire mesh surface properties (hydrophilic or hydrophobic) on single bubble cutting in a glycerol-air system. The experiments will be used to validate 3D-direct numerical simulations.

DISSERTATIONS

-

SCIENTIFIC PUBLICATIONS

1. K. Thiruvalluvan Sujatha, B.G.J. Meeusen, N. G. Deen, and J. A. M. Kuipers. "Experimental Studies of Bubbly Flow in a Pseudo-2D Micro-Structured Bubble Column Reactor Using Digital Image Analysis." Chemical Engineering Science (2015).

PROJECTLEADERS

NG Deen

RESEARCHTHEME

Mathematical and computational methods for fluid flow analysis

PARTICIPANTS

K Thiruvalluvan Sujatha, NG Deen, JAM Kuipers

COOPERATIONS

HZDR, Dresden, Germany.

FUNDED

European Research Council (ERC)

University	-
FOM	-
STW	-
NWO Other	-
Industry	-
TNO	-
GTI	-
EU	100 %
Scholarships	-

START OF THE PROJECT

2012

INFORMATION

NG Deen
040 247 3681 / 2140
N.G.Deen@TUE.nl

NOVEL EXPERIMENTAL TECHNIQUES FOR DENSE GRANULAR FLOW

PROJECT LEADERS

JAM Kuipers

RESEARCH THEME

Complex dynamics of fluids

PARTICIPANTS

KA Buist, NG Deen, JAM Kuipers

COOPERATIONS

-

FUNDED

European Research Council (ERC)

University -

FOM -

STW -

NWO Other -

Industry -

TNO -

GTI -

EU 100 %

Scholarships -

START OF THE PROJECT

2012

INFORMATION

KA Buist

040 247 8021

K.A.Buist@tue.nl

www.tue.nl

PROJECT AIM

The primary objective of this study is to develop new experimental techniques to study particle-fluid interactions (heat transfer). The second goal is to use these techniques to complement and validate the knowledge gained with the multi-scale modelling approach.

PROGRESS

Last year has been spent to further develop a new particle tracking technique, called Magnetic Particle Tracking. The first findings have been written down and published in AIChE journal. Experiments have been performed to study the rotation of particles in a fluidized bed, the findings have been compared to discrete particle simulations. The results of this are currently written down and will be submitted to AIChE. Second a novel setup has been developed and tested to study heat transfer in semi-structured arrays, we are currently in the progress of finalizing our experiments and comparison to direct numerical simulations.

DISSERTATIONS

-

SCIENTIFIC PUBLICATIONS

1. Buist, K.A., Gaag, A.C. van der, Deen, N.G. & Kuipers, J.A.M. (2014). Improved magnetic particle tracking technique in dense gas fluidized beds. AIChE Journal : Chemical Engineering Research and Development, 60(9), 3133-3142.
2. Buist, K.A., Erdewijk, T.W. van, Deen, N.G. & Kuipers, J.A.M. (2015). Determination and comparison of rotational velocity in a pseudo 2D fluidized bed using Magnetic Particle Tracking and Discrete Particle Modelling. AIChE Journal : Chemical Engineering Research and Development, 61(10), 3198-3207.
3. Buist, K.A., Backx, B.J.G.H., Deen, N.G. & Kuipers, J.A.M. (2016). A combined experimental and simulation study of fluid-particle heat transfer in dense arrays of stationary particles. Submitted to Chemical Engineering Science.

MULTISCALE MODELING OF GAS-SOLID MASS TRANSFER AND ITS IMPACT ON RISER PERFORMANCE

PROJECT AIM

The objective of the project is to conduct a combined experimental and computational investigation on the impact of heterogeneity on riser reactor performance. A laboratory scale riser set up is used to characterize the hydrodynamics and particle-cluster formation using image-velocimetry combined with digital image analysis. Mass transfer characteristics are measured by using ozone decomposition by catalyst particles. CFD-DEM simulations are performed to validate the model, using the experimental data.

PROGRESS

A novel Digital Image Analysis (DIA) technique has been developed. This DIA technique, is insensitive to inhomogeneous lighting gradients and shadows, enabling full-field accurate measurements of solids volume fraction on a pseudo-2D riser reactor. DIA is combined with Particle Image Velocimetry to characterize riser hydrodynamics under diverse operational conditions. This combined experimental technique also enables detection of clustered regions and obtain a large amount of data related to cluster properties. These experiments have been employed to validate the reliability of a CFD-DEM. This model is found to predict satisfactorily riser hydrodynamics as well as clustering phenomena.

DISSERTATIONS

-

SCIENTIFIC PUBLICATIONS

1. A.C.Varas, E.A.J.F. Peters, N.G.Deen, and J.A.M. Kuipers. Numerical and experimental characterization of particle clusters in riser flow. Proceedings of the 11th International Conference on Computational Fluid Dynamics in the Minerals and Process Industries CSIRO, 7-9 December 2015, Melbourne Australia.
2. A.C.Varas, E.A.J.F. Peters, N. Deen, J.A.M. Kuipers. Computational and experimental study of cluster formation in riser flow. NWO's CHAINS 2015, the Dutch Chemistry Conference, 30 Nov-3 December, Eindhoven Netherlands.

PROJECT LEADERS

JAM Kuipers

RESEARCH THEME

Complex structures of fluids

PARTICIPANTS

A Carlos Varas, EAJF Peters, JAM Kuipers

COOPERATIONS

-

FUNDED

NWO-CW	
University	-
FOM	-
STW	-
NWO Other	100 %
Industry	-
TNO	-
GTI	-
EU	-
Scholarships	-

START OF THE PROJECT

2013

INFORMATION

A Carlos Varas
06 19804533
a.e.carlos.varas@tue.nl

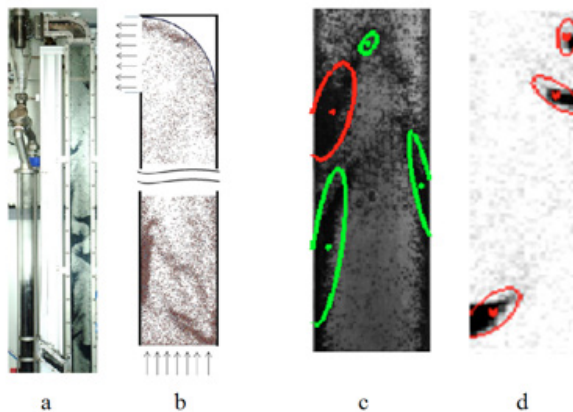

Figure a: Snapshot of experimental setup. b: pseudo-2D riser system in CFD-DEM model. c: Clusters detected in experimental setup. d: Clusters detected in simulations.

MULTI-SCALE MODELLING OF MASS, MOMENTUM AND HEAT TRANSFER IN ADSORPTION DRYERS

PROJECT LEADERS

JAM Kuipers

RESEARCH THEME

Mathematical and computational methods for fluid flow analysis

PARTICIPANTS

D Cheng, EAJF Peters, JAM Kuipers

COOPERATIONS

-

FUNDED

University	-
FOM	-
STW	-
NWO Other	-
Industry	100 %
TNO	-
GTI	-
EU	-
Scholarships	-

START OF THE PROJECT

2014

INFORMATION

JAM Kuipers
040 247 4158
j.a.m.kuipers@tue.nl

PROJECT AIM

The objectives of the proposed research is the development of a comprehensive software tool that enables the calculation of an adsorption dryer device that can be used for optimization of existing units and explore the feasibility for specific future customer needs. The validated model is expected to serve as a workhorse in should include all relevant physical phenomena of the process including mass, momentum and heat transfer prevailing at different time and length scales.

PROGRESS

A hierarchy of models (1D/2D/3D) have been built. A comparative study between 1D model and 3D model is carried out. The 1D and 3D model predictions are validated against literature experimental data for the example of water vapor adsorption and desorption operated in a cyclic counter-flow arrangement. The obvious heat and adsorbate concentration gradients observed in both radial and circumferential directions indicate that the detailed 3D model is indispensable. A systematical parametric study has been done based on the rigorous 3D model, in which the effects of thermal conductivity of adsorbent layer, specific heat, porosity, tortuosity, layer thickness and geometrical shape on the performance of moisture adsorption processes are investigated. The concomitant heat and mass transfer mechanisms in the investigated cases are thoroughly analysed taking advantage of the robust 3D model, which deepens our understanding on such non-linear complicated processes.

DISSERTATIONS

-

SCIENTIFIC PUBLICATIONS

1. Dang Cheng, E.A.J.F. Peters, J.A.M. Kuipers. Numerical modelling of flow and coupled mass and heat transfer in a rotary desiccant wheel, 11th International Conference on Computational Fluid Dynamics in the Minerals and Process Industries, Dec 7-9, 2015, MCEC, Melbourne, Australia.

TRANSPORT PHENOMENA AND CHEMICAL REACTION IN SLENDER BUBBLE COLUMNS WITH OPEN-STRUCTURE RANDOM PACKING

PROJECT AIM

The objective is to obtain quantitative data and theoretical insights in the hydrodynamics and transport phenomena in a slender bubble column reactor filled with an open structure random packing (OSRP) through numerical simulation. A combined VOF-IBM (Volume Of Fluid and Immersed Boundary Method) based CFD code is developed, tested and rewritten for HPC (High Performance Computing) environment to obtain results in a realistic time-frame. Numerical results will be compared with experimental findings.

PROGRESS

A parallel IBM code including Conjugate Heat Transfer model has been developed.

DISSERTATIONS

-

SCIENTIFIC PUBLICATIONS

-

PROJECTLEADERS

JAM Kuipers, NG Deen

RESEARCHTHEME

Mathematical and computational methods for fluid flow analysis

PARTICIPANTS

S Das, NG Deen, JAM Kuipers

COOPERATIONS

-

FUNDED

University	-
FOM	-
STW	-
NWO Other	-
Industry	100 %
TNO	-
GTI	-
EU	-
Scholarships	-

START OF THE PROJECT

2013

INFORMATION

S Das
040 247 8182
s.das@tue.nl

PROJECT LEADERS

JT Padding, EAJF Peters

RESEARCH THEME

Mathematical and computational methods for fluid flow analysis

PARTICIPANTS

S De, JT Padding, EAJF Peters, JAM Kuipers

COOPERATIONS

Dr. Albert Janssen- SHELL
Dr. Cor.van Kruijsdijk – SHELL

FUNDED

FOM, Shell	
University	-
FOM	50 %
STW	-
NWO Other	-
Industry	50 %
TNO	-
GTI	-
EU	-
Scholarships	-

START OF THE PROJECT

2013

INFORMATION

JT Padding,
040 247 3674,
j.t.padding@tue.nl

PROJECT AIM

Polymer liquids are used in the oil industry to improve the volumetric sweep and displacement efficiency of the oil from a reservoir. Surprisingly, it is not only the viscosity but also the elastic properties of the displacing fluid that determine the displacement efficiency. This may be caused by the ability of a viscoelastic fluid to pull oil out of dead-ends. The objective of the project is to develop a computer simulation methodology for the flow of non-Newtonian fluids through porous media. This will enable us to gain a fundamental understanding of the effects of fluid elasticity and interfacial tension between the oil phase and the displacing fluid on the recovery efficiencies.

PROGRESS

Computational Fluid Dynamics (CFD) based code has been developed. Advanced Maxwell models (FENE-P, PTT Models) which can capture shear and extensional viscosity of polymer have been incorporated in the model. A second order IBM method has been implemented, to model the porous media. The validated coupled IBM viscoelastic model is used to model realistic porous media flow. The complex effect of rheology and fluid motion will be studied for different pore structures. Micro-PIV experiments are performed in a pillared microchannel to observe flow characteristics of viscoelastic fluid in a model porous media. Flow instabilities are observed at higher viscoelasticity. Currently two phase (oil and polymer) micro-piv experiments are performed in this set up to obtain insights of an actual enhanced oil recovery process.

DISSERTATIONS

-

SCIENTIFIC PUBLICATIONS

1. S. De, E.A.J.F. Peters, J.A.M. Kuipers, J.T. Padding, Viscoelastic Flow Modelling for Polymer Flooding. Conference Proceeding: AICHE Annual meeting, Salt lake city, USA, Nov 2015.
2. S. De, E.A.J.F. Peters, J.A.M. Kuipers, J.T. Padding, Viscoelastic Flow Modelling in Porous Media Conference Proceeding: American Physical Society – 68th Annual DFD Meeting, Boston, Nov 2015.
3. S. De, S.Das, E.A.J.F. Peters, J.A.M. Kuipers, J.T. Padding, A coupled finite volume immersed boundary method for simulating 3D viscoelastic flows in porous media, submitted to JNNFM, 2015.

3D Viscoelastic Flow streamlines through a periodic array of cylinders (Coloured with velocity)

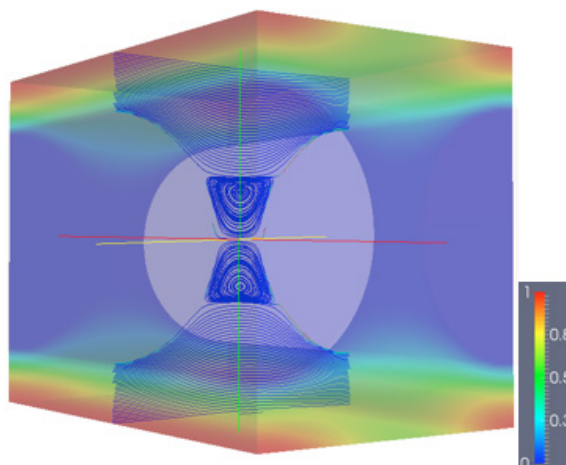

MULTISCALE EXPERIMENTS AND SIMULATIONS OF AGGLOMERATION IN SPRAY DRIERS

PROJECT AIM

The main goal of the project is: to provide Tetra Pak with experimentally validated predictive computational tools that can be used to tailor spray drier operations. The first part of the project is based on the investigation of viscous effect on droplet interactions. Binary droplet collisions are analyzed numerically through DNS and experimentally through droplet generator device. The obtained results will be used to develop theoretical model for the description of collision outcomes boundaries.

PROGRESS

The DNS VOF in-house code has been modified in order to perform binary droplet collisions for different impact parameters and We numbers. The purpose is to obtain a regime map with the different collision outcomes (example of separation in Fig.1 (a)). The viscous dissipation energy has been implemented in order to track its evolution during collision phenomenon for different conditions (example of dissipation energy rate [J/s] trend during collision event in Fig.1 (b)). The experimental set up has been designed and developed. A support structure for the precise regulation of relative nozzles positions has been built. The phenomenological models for the collision outcomes have been developed with the inclusion of energy dissipation in the energy balances. The models have been compared with numerical results and will be validated by experiments. This investigation, based on the micro scale, will be used to find a closure for the macro scale model on a spray.

DISSERTATIONS

-

SCIENTIFIC PUBLICATIONS

1. AN EXPERIMENTAL STUDY OF DROPLET-PARTICLE COLLISIONS, G. Finotello, S. K. Pawar, F. Henrikson, J. T. Padding, N. G. Deen, A. Jongsma, F. Innings, J.A.M. (Hans) Kuipers, 7h International Granulation Workshop, The University of Sheffield, UK, 1st-3rd July 2015.
2. STUDY OF THE EFFECT OF VISCOSITY ON BINARY DROPLET, G. Finotello, J. T. Padding, N. G. Deen, A. Jongsma, F. Innings, J.A.M. (Hans) Kuipers, 14TH Workshop on Two-Phase Flow Predictions, Halle(Saale), Germany, 7th -10th September 2015.

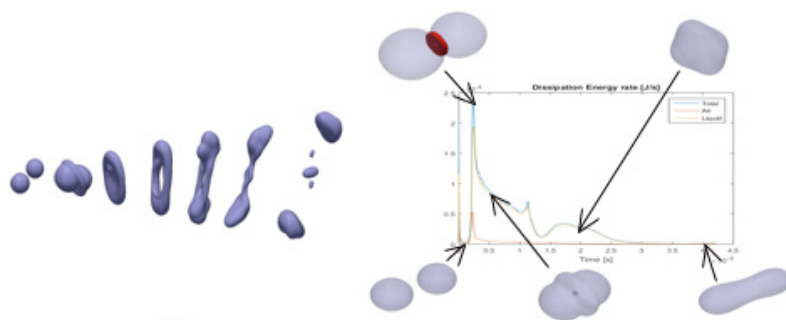

(a) example of separation (b) example of dissipation energy rate [J/s] during collision

PROJECT LEADERS

JAM Kuipers, JT Padding

RESEARCH THEME

Mathematical and computational methods for fluid flow analysis

PARTICIPANTS

G Finotello, JT Padding, JAM Kuipers

COOPERATIONS

Tetra Pak

FUNDED

University	-
FOM	-
STW	-
NWO Other	-
Industry	100 %
TNO	-
GTI	-
EU	-
Scholarships	-

START OF THE PROJECT

2014

INFORMATION

G Finotello
040 247 2589
G.Finotello@tue.nl

DIRECT NUMERICAL SIMULATION (DNS) OF TRANSPORT AND CHEMICAL REACTION IN THREE-PHASE FLOWS

PROJECT LEADERS

JAM Kuipers

RESEARCH THEME

Mathematical and computational methods for fluid flow analysis

PARTICIPANTS

S Islam, EAJF Peters, JAM Kuipers

COOPERATIONS

-

FUNDED

NWO-CW

University -

FOM -

STW -

NWO Other 100 %

Industry -

TNO -

GTI -

EU -

Scholarships -

START OF THE PROJECT

2014

INFORMATION

Md Shafiul Islam

040 247 8870

M.S.Islam@tue.nl

PROJECT AIM

In the past decades, many researchers have predicted the behavior of mass transfer gas-liquid-solid using fixed grid approaches. As the mass boundary layer is very thin compared to the momentum boundary layer, fixed grid approaches require fine grids, which makes the computation very expensive. To overcome this issue, we follow the technique of mass boundary layer method embedded in front tracking model to simulate the mass transfer of bubble. Due to the coupling of mass boundary layer method with a front tracking method, the computation becomes feasible.

PROGRESS

In our present work, we implemented the mass boundary layer method by considering creeping flow and potential flow of a rising spherical bubble. Although the implementation of mass boundary layer method is quite arduous, it doesn't suffer from the inadequate expenditure of the computation. For proper verification of mass transfer, Sherwood number (Sh) with respect to different values of the Peclet (Pe) and Reynolds number (Re) are compared with analytical solution, both for creeping flow and potential flow. Eventually, the transferred mass and received mass from bubble side and flow domain are also verified in well manner.

DISSERTATIONS

-

SCIENTIFIC PUBLICATIONS

-

CLINGCO2: CHEMICAL LOOPING REFORMING FOR PURE HYDROGEN PRODUCTION WITH INTEGRATED CO₂ CAPTURE

PROJECT AIM

A Chemical Looping reactor concept for CO₂ capture with immersed Pd-membranes for hydrogen separation using CH₄ as fuel is proposed in this project. The development of the project combines deep investigation on thermodynamics, hydrodynamics of the reactor, mass transfer measurements and selection of the catalyst for the process. All these measurements will help in the optimization of the reactor and its scale-up to lab scale demonstration. A phenomenological model able to describe the behaviour of the concept will be also developed during the project. Finally, a techno-economical analysis will be carried out to demonstrate the applicability at larger scales.

PROGRESS

During the last year different novel Pd-based metallic supported membranes have been studied and it has been found that they are able to withstand high temperatures with outstanding selectivities for H₂ separation. Furthermore, fundamental aspects on the hydrodynamics of a circulating fluid bed (representing the chemical looping system) have been investigated, where two novel methods for an accurate measurement of solids circulation rates have been developed and will be subsequently used in the lab scale demonstration setup. In addition, an experimental technique based on infrared digital image analysis has been further extended to enable mass transfer studies in fluidized beds with the aim to develop improved closure correlations. This novel technique also allows the combination of mass transfer and hydrodynamics at once. Finally, this information has been implemented in a novel phenomenological model to describe the proposed reactor.

DISSERTATIONS

-

SCIENTIFIC PUBLICATIONS

1. J.A. Medrano et al, Applied Energy, 158 (2015), 86-96.
2. J.A. Medrano et al, Chemical Engineering Journal, 282 (2015), 45-57.
3. J.A. Medrano et al, International Journal of Hydrogen Energy (2015), <http://dx.doi.org/10.1016/j.ijhydene.2015.10.094>.
4. E. Fernandez et al, Chemical Engineering Journal (2015), <http://dx.doi.org/10.1016/j.cej.2015.09.119>.



Schematic description of the reactor concept developed in this project

PROJECT LEADERS

F Gallucci, M van Sint Annaland

RESEARCH THEME

Complex dynamics of fluids

PARTICIPANTS

JA (José Antonio) Medrano Jiménez,
R (Ramon) Voncken and
Dr. V (Vincenzo) Spallina

COOPERATIONS

-

FUNDED

STW	
University	-
FOM	-
STW	100 %
NWO Other	-
Industry	-
TNO	-
GTI	-
EU	-
Scholarships	-

START OF THE PROJECT

2013

INFORMATION

JA Medrano Jimenez
040 247 8055
06 42 055 727
j.a.medrano.jimenez@tue.nl

CHEMICAL LOOPING REFORMING FOR PURE HYDROGEN PRODUCTION WITH INTEGRATED CO₂ CAPTURE (CLINGCO₂)

PROJECT LEADERS

F Gallucci, I Roghair, M van Sint Annaland

RESEARCH THEME

Mathematical and computational methods for fluid flow analysis

PARTICIPANTS

RJW Voncken, JA Medrano Jimenez

COOPERATIONS

STW, Sintef, Tecnalia, Shell, ECN, Air Products, Hygear

FUNDED

STW	
University	-
FOM	-
STW	100 %
NWO Other	-
Industry	-
TNO	-
GTI	-
EU	-
Scholarships	-

START OF THE PROJECT

2013

INFORMATION

RJW Voncken
040 247 8180
r.j.w.voncken@tue.nl

PROJECT AIM

The project aims to develop a novel reactor concept for the production of ultra-pure hydrogen with integrated CO₂ capture. The reactor concept is based on overall auto-thermal reforming of methane in a fluidized bed reactor where immersed hydrogen perm-selective membranes are used to extract and simultaneously purify the hydrogen whilst driving the equilibria towards the desired hydrogen product and where the energy and oxygen necessary for the reforming is provided via chemical looping. The following sub-goals were set:

- Quantifying the hydrodynamics and mass transfer phenomena in fluidized bed reactors containing hydrogen perm-selective membranes in various configurations
- Quantifying the effect of net gas production via steam methane reforming on the performance of fluidized bed membrane reactor systems.
- Understanding and describing the effects of solids circulation in systems with an interconnected fluidized bed and riser.
- Performing a scale-up and parametric study of fluidized bed membrane reactor systems.

PROGRESS

Hydrogen concentration profiles in gas-solid fluidized bed membrane reactors have been quantified by performing Two Fluid Model (TFM) simulations. Both vertically and horizontally immersed hydrogen perm-selective membranes have been investigated. The vertical membranes clearly suffer from concentration polarization, which reduces the hydrogen flux and thus the effectiveness of the system. Horizontally immersed membranes affect both the hydrodynamics and the mass transfer phenomena of the system, see Figure 1. Particularly the membranes near the walls suffer from reduced hydrogen concentrations, because the down flow of solids near the walls causes densified zones on top of the membranes. Below the membranes, gas pockets (non-rising gas bubbles devoid of particles) prevail, which may affect the mass transfer towards the membranes. These results will subsequently be used to improve phenomenological models for fluidized bed membrane reactors.

DISSERTATIONS

-

SCIENTIFIC PUBLICATIONS

1. J.A. Medrano, R.J.W. Voncken, I. Roghair, F. Gallucci and M. van Sint Annaland (2015). On the effect of gas pockets surrounding membranes in fluidized bed membrane reactors: An experimental and numerical study. Chem. Eng. J. 282:45-57.

Time-averaged hydrogen mole fraction and solids hold-up in a fluidized bed with horizontally immersed membranes in in-line configuration

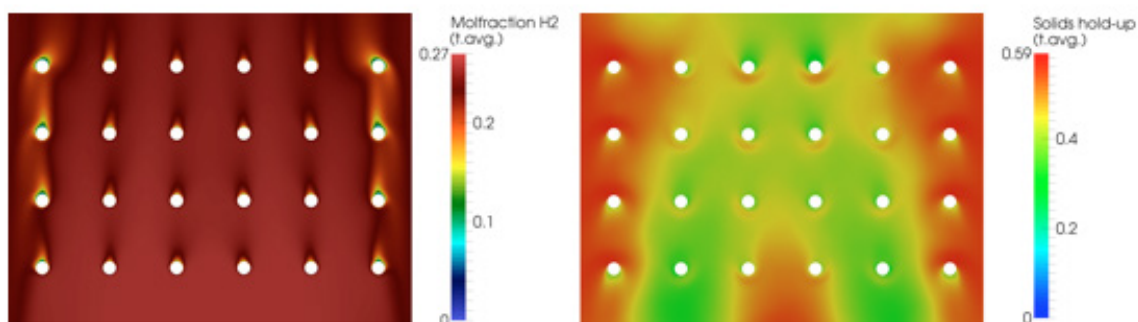

SIMULATION OF LARGE SCALE GAS LIQUID SOLID FLOWS WITH STOCHASTIC EULER-LAGRANGIAN METHODS

PROJECT AIM

To develop model for large scale slurry bubble columns using stochastic Euler-Lagrangian methods. Deterministic methods like the discrete bubble model provide a detailed enough information on the type of flow and also track position of all bubbles at the same time. This rather becomes quite expensive considering collisions especially in the dense bubbly flow regime which is the situation in industrial slurry columns. On the other hand multi-fluid models do not resolve bubble interactions which makes the model susceptible to large errors.

PROGRESS

The project has recently started. Currently the stochastic model will be applied to a bubbly flow system will be compared with a deterministic model like discrete bubble model in terms of bubble-bubble interactions and encounters. This model will then be coupled with a more efficient (parallelized) flow solver for speed improvements.

DISSERTATIONS

-

SCIENTIFIC PUBLICATIONS

-

PROJECTLEADERS

JT Padding, JAM Kuipers

RESEARCHTHEME

Mathematical and computational methods for fluid flow analysis

PARTICIPANTS

SS Kamath, JT Padding, JAM Kuipers

COOPERATIONS

-

FUNDED

NWO-CW	
University	-
FOM	-
STW	-
NWO Other	100 %
Industry	-
TNO	-
GTI	-
EU	-
Scholarships	-

START OF THE PROJECT

2015

INFORMATION

S Kamath
06 42276507
s.s.kamath@tue.nl
j.t.padding@tue.nl

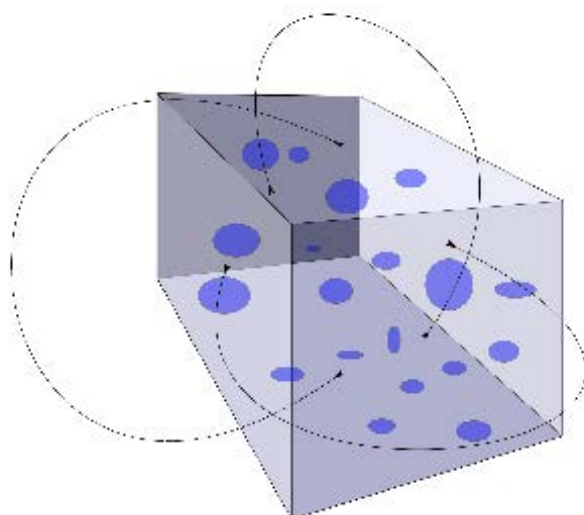

EXPERIMENTAL STUDY OF TRANSPORT AND CHEMICAL REACTION IN THREE-PHASE FLOWS

PROJECT LEADERS

JAM Kuipers

RESEARCH THEME

Mathematical and computational
methods for fluid flow analysis

PARTICIPANTS

G Kong, EAJF Peters, JAM Kuipers

COOPERATIONS

-

FUNDED

NWO-CW	
University	-
FOM	-
STW	-
NWO Other	100 %
Industry	-
TNO	-
GTI	-
EU	-
Scholarships	-

START OF THE PROJECT

2015

INFORMATION

G KONG
040 247 8199
g.kong@tue.nl

PROJECT AIM

Mass transfer and transport is immensely important in chemical engineering, but local measurement is extremely difficult in multiphase flow due to complicated optical issues, in this project dual LIF technique is employed and developed to overcome the problems.

PROGRESS

Dye and optical measuring system are carefully selected and integrated.

DISSERTATIONS

-

SCIENTIFIC PUBLICATIONS

-

PREDICTIVE MODELLING OF POLYOLEFIN REACTORS

PROJECT AIM

To extend the discrete particle model and multi-fluid model with heat and mass balances to obtain an accurate description of polymerization processes on a lab-scale system and bench scale system under actual process conditions, i.e. involving reaction, significant heat production and high pressures.

PROGRESS

DPM (discrete particle model) simulations for fluidized bed with heat production. A constant volumetric heat source term has been implemented in the heat transfer model. Firstly the mono-dispersed particles are used in the simulations to perform the influences of the operation condition on the heat transfer and particle temperature distribution. The results have been summarized in two publications. Later on, Particles with Gaussian size distribution have been taken into consideration to investigate hot spots formation in the olefin polymerization reactors. It is found that these fine particles with high heat producing which are located above the free-board or at the side walls can be overheated and lead to form hot spots. To validate the simulation results, a new combined IR (infrared)/PIV (particle image velocimetry)/DIA (digital image analysis) measuring technique has been recently developed in the group. A high resolution IR camera and a high speed visual camera are combined together to get the visual image of particles positions and the temperature distribution simultaneously (shown as the images below).

DISSERTATIONS

-

SCIENTIFIC PUBLICATIONS

1. Z. Li, M. van Sint Annaland, J.A.M. Kuipers, N.G. Deen, Effect of superficial gas velocity on the particle temperature distribution in a fluidized bed with heat production, Chem. Eng. Sci. 140 (2016) 279–290.

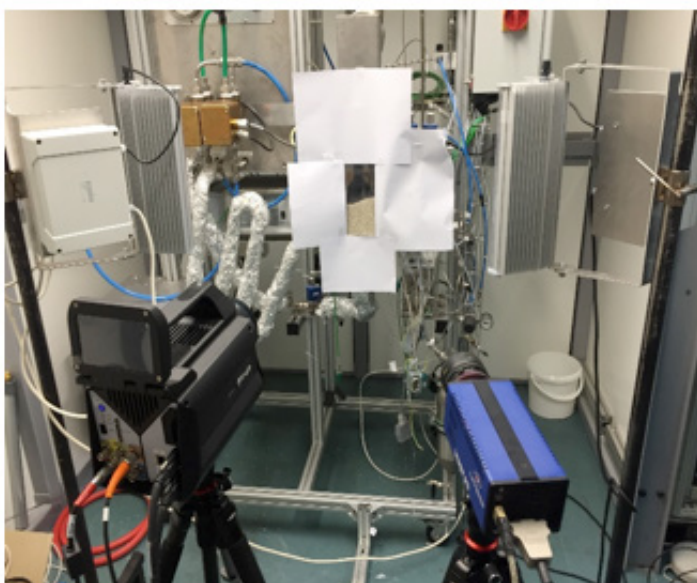

Illustration of the set-up with two cameras: the X8400SC FLIR IR camera, resolution 1280×1024 pixels(left); and LaVision ImagerPro, resolution 560×1280 pixels (right).

PROJECTLEADERS

JAM Kuipers, NG Deen, M van Sint Annaland

RESEARCHTHEME

Mathematical and computational methods for fluid flow analysis

PARTICIPANTS

Z Li, M Banaei, JAM Kuipers, NG Deen, M van Sint Annaland

COOPERATIONS

DPI

FUNDED

University	-
FOM	-
STW	-
NWO Other	-
Industry	100 %
TNO	-
GTI	-
EU	-
Scholarships	-

START OF THE PROJECT

2012

INFORMATION

Z Li
040 247 8027
z.z.li@tue.nl

FLOW MRI IN PACKED AND FLUIDIZED BEDS

PROJECT LEADERS

JAM Kuipers

RESEARCH THEME

Complex dynamics of fluids

PARTICIPANTS

P Lovreglio, EAJF Peters, L Pel,
JAM Kuipers

COOPERATIONS

-

FUNDED

Netherlands Center for Catalytic
Energy Conversion (MCEC)

University -

FOM -

STW -

NWO Other 100 %

Industry -

TNO -

GTI -

EU -

Scholarships -

START OF THE PROJECT

2014

INFORMATION

P Lovreglio

040 247 8871

p.lovreglio@tue.nl

PROJECT AIM

In most chemical processes flow systems are multiphase flows and not transparent. We use MRI to visualize the flow, which we cannot see with optical (camera) techniques, and obtain quantitative data in cases where processes taking place in the interior remain obscure, which is often a major limitation. Experimental results are needed to validate complex computational models, developed to simulate the flow in multiphase systems of industrial relevance, like packed and fluidized beds.

PROGRESS

An experimental setup, to study structure and hydrodynamics in a packed bed of spherical particles by means of MRI, was built and used to determine phase fractions and the axial velocity of water. Phase fractions were evaluated by processing 3-D datasets of the packed bed, obtained with MRI, while the axial velocity of water, flowing through the bed, was acquired by directly encoding velocity values with a method suitable for Flow MRI studies. Results for a slice are shown in Fig. 1. CFD simulations of the experimental system were performed using a DEM code to generate the packing of spherical particles and an in-house IBM-DNS code to evaluate porosity and flow inside the bed.

DISSERTATIONS

-

SCIENTIFIC PUBLICATIONS

-

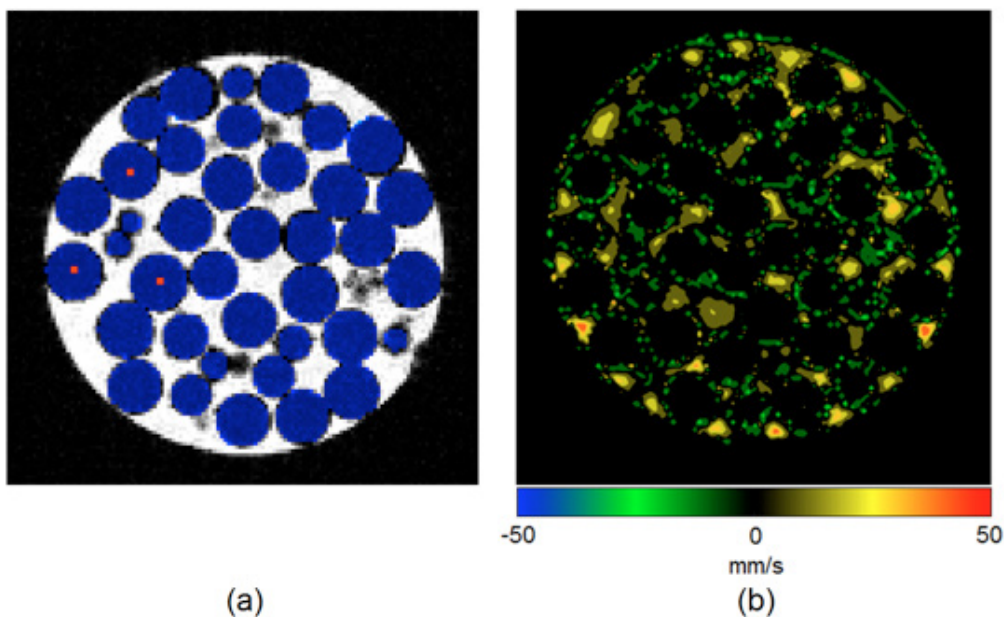

Experimental phase fractions (a) and axial velocity of water (b) for a slice obtained by means of MRI applied to a packed bed of spherical particles

MC-DNS STUDY OF MASS TRANSFER WITH CATALYTIC SURFACE REACTION

PROJECT AIM

Quantitatively model the mass transport chain for realistic processes with multicomponent reactant and product mixtures, polydisperse particles and catalytic reaction kinetics. With this full synthesized model, it is expected to give prediction of the performance of an industrial catalytic conversion process by computer simulation, which will give insight in the interplay of transport and reactivity, and therefore real chemical processes can be optimized.

PROGRESS

Implementation of 3D mass transport equation to describe the flow of species around catalytic particles. Implementation of directional quadratic interpolation scheme for the Immersed boundary method. Implementation of quadratic interpolation scheme for the Immersed boundary method. Realization of above mentioned two schemes in fluid-solid interface for sphere and pipe cases.

DISSERTATIONS

-

SCIENTIFIC PUBLICATIONS

-

PROJECTLEADERS

JAM Kuipers

RESEARCHTHEME

Complex dynamics

PARTICIPANTS

J Lu, EAJF Peters, RE Bulo,
RA van Santen, JAM Kuipers

COOPERATIONS

Utrecht University

FUNDED

Netherlands Center for Multiscale
Catalytic Energy Conversion (MCEC)

University	-
FOM	-
STW	-
NWO Other	100 %
Industry	-
TNO	-
GTI	-
EU	-
Scholarships	-

START OF THE PROJECT

2014

INFORMATION

J Lu
040 247 8868
j.lu1@tue.nl

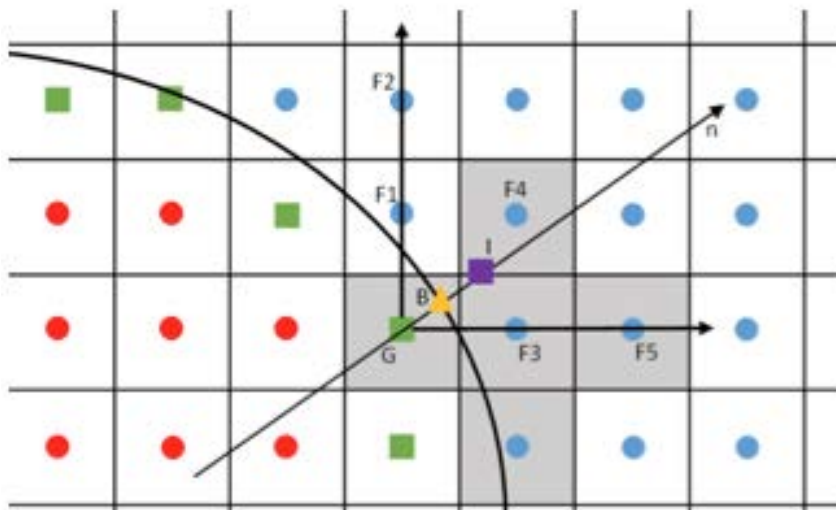

MULTISCALE MODELLING OF FLUIDIZED NON-SPHERICAL PARTICLES: WALL PROXIMITY EFFECTS

PROJECT LEADERS

JT Padding

RESEARCH THEME

Mathematical and computational methods for fluid flow analysis

PARTICIPANTS

VV Mahajan, JT Padding,
B Fitzgerald, JAM Kuipers

COOPERATIONS

-

FUNDED

European Research Council (ERC)

University -

FOM -

STW -

NWO Other -

Industry -

TNO -

GTI -

EU 100 %

Scholarships -

START OF THE PROJECT

2014

INFORMATION

V Mahajan
040 247 3295
v.v.mahajan@tue.nl

PROJECT AIM

The project aims at a full understanding of the hydrodynamics of fluidized beds containing non spherical (rod-like) particles. The main task of this project is to implement a DPM code for rod-like particles, incorporate new drag relations for translational and rotational hydrodynamic forces (obtained from DNS simulations), and to validate these closures using PIV/DIA measurements in quasi-2D fluidized beds. Novel concepts will be the inclusion of wall proximity effects (e.g. lift forces and particle orientation effects) for non-spherical particles and the detection of particle orientation and angular velocity using PIV/DIA.

PROGRESS

In the last year, new strategy of exact analytical calculation for DPM modelling of non-spherical (spherocylindrical) particles was implemented in DPM open-source code LIGGGHTS. Coupling with flowsolver (Openfoam) was also established using the existing open-source CFD/DEM coupling framework. The developed code will now be tested with packed bed simulations, against predictions of standard Ergun equation for pressure drop across the bed. Experiments for fluidized bed of these particles are planned in the coming year.

DISSERTATIONS

-

SCIENTIFIC PUBLICATIONS

-

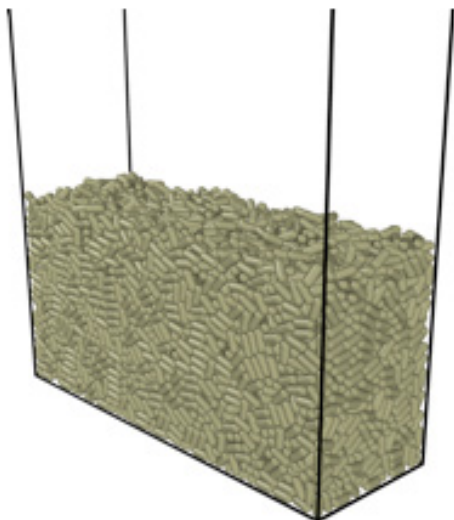

A snapshot of packed bed of 8000 spherocylindrical particles simulated using the newly developed DPM code.

SIMULATION OF PROPPANT TRANSPORT FOR SHALE GAS PRODUCTION

PROJECT AIM

In shale formations the gas-permeability is increased by injecting complex particle-filled liquids (fracking). The so-called proppant particles prevent the fractures from fully closing when the flow of liquid is stopped. In order to predict where the particles deposit in a network of fractures we need to know how proppant is transported in a network of fractures. This research is aimed at modeling the particle transport on the relevant length scales. Three scales of coarse-grained computational multiphase fluid modeling will be used to analyse the sedimentation of particles. At all these scales, we will consider the behavior of sedimenting proppant particles at higher Reynolds number and/or in a viscoelastic medium. The creation of porous beds, also for polydisperse mixtures of grain-sizes, and the distribution of proppant in a network of fractures will be investigated.

PROGRESS

To understand the proppant transport at various flow conditions in rock fractures, 3D CFD model is developed. Sharp-interface ghost cell immersed boundary method (IBM) is implemented to account for the fluid-solid interaction. Moreover, there will be an interaction between solid-solid particles as well and this is accounted through the use of discrete element model (DEM) consisting of lubrication model and the collision model. The combined immersed boundary – discrete element model (IB-DEM) model is used for direct numerical simulation (DNS) of particle-laden flows and to improve the understanding of the transport phenomenon of proppants. The developed code is validated for single and multiple particle system at varying Reynolds number. The sample figure of two-particle sedimentation case is presented. This is also called as drafting-kissing-tumbling case, defining the stages during sedimentation.

DISSERTATIONS

-

SCIENTIFIC PUBLICATIONS

-

PROJECT LEADERS

EAJF Peters, JT Padding

RESEARCH THEME

Mathematical and computational methods for fluid flow analysis

PARTICIPANTS

R Maitri, EAJF Peters, JT Padding, JAM Kuipers

COOPERATIONS

Dr. Johan Romate- SHELL

FUNDED

FOM, Shell	
University	-
FOM	50 %
STW	-
NWO Other	-
Industry	50 %
TNO	-
GTI	-
EU	-
Scholarships	-

START OF THE PROJECT

2014

INFORMATION

R Maitri
040 247 4487
r.maitri@tue.nl

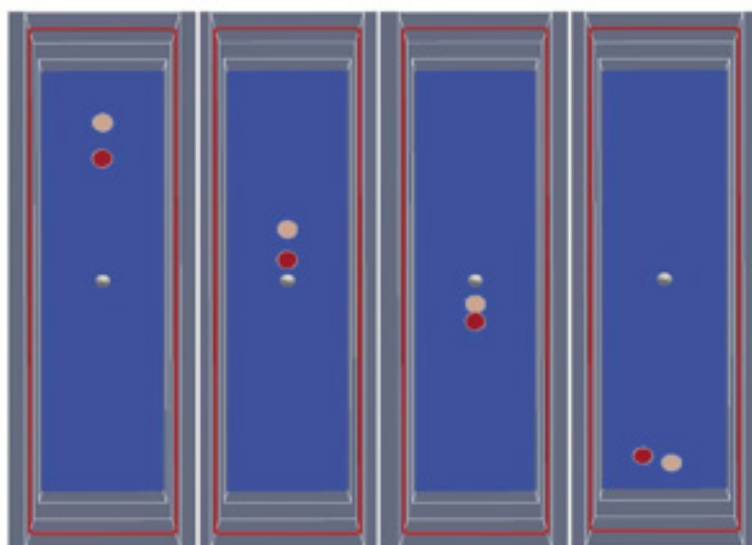

FLOW STRUCTURE FORMATION AND COUPLING WITH TURBULENCE IN LARGE SCALE SLURRY BUBBLE COLUMN

PROJECT LEADERS

JT Padding, JAM Kuipers

RESEARCH THEME

Mathematical and computational methods for fluid flow analysis

PARTICIPANTS

MV Masterov, JT Padding,
JAM Kuipers

COOPERATIONS

-

FUNDED

Netherlands Center for Catalytic Energy Conversion (MCEC)

University -

FOM -

STW -

NWO Other 100 %

Industry -

TNO -

GTI -

EU -

Scholarships -

START OF THE PROJECT

2015

INFORMATION

Masterov Maxim Vadimovich

06 28299432

m.v.masterov@tue.nl

<http://padding.awardspace.info/>

PROJECT AIM

Our aim is to obtain a better understanding of the hydrodynamics and heat- and mass-transfer limitations, and the role of turbulence in large scale slurry bubble columns using state-of-the-art computer simulations. We are concentrating on development of a high performance parallel code and new models and approaches to predict phase interactions and aim to achieve a detailed resolution of turbulent structures and prediction of the bubble dynamics by using Direct Simulation Monte Carlo (DSMC).

PROGRESS

The solution of 3d transient multiphase flow on large scales is computationally time consuming and demand, both in terms of CPU-time and memory requirements. The most significant part of numerical techniques we are using is a solving of a large sparse matrices. Thus, we were concentrating on development of a new high performance library of linear solvers. We have taken as a basis Krylov Subspace solvers (CG family) accelerated with Algebraic Multigrid method. The code has been tested on a large number of model problems and showed good performance and robustness in comparison with widely used ICCG method.

DISSERTATIONS

-

SCIENTIFIC PUBLICATIONS

-

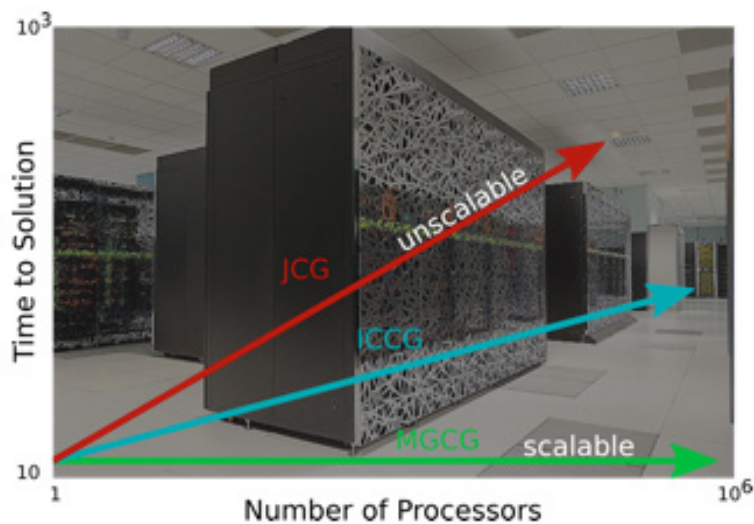

MULTISCALE MODELLING OF DENSE GAS-FLUIDIZED FLOWS OF NON-SPHERICAL PARTICLES: BULK DPM

PROJECT AIM

This project is a part of the Multiscale modelling of dense gas-fluidized flows of non-spherical particles project. This sub-project focuses on in bulk effects and particle size aspect ratio. It's aim is to develop a functional Discrete Particle Model for simulation of dense gas-solid flows of inelastic non-spherical particles and validate it with in-house Magnetic Particle Tracking experiments. This model will subsequently be used to obtain particle stress correlations for a more coarse-grained multi-particle collision model.

PROGRESS

A literature overview of discrete particle models (DPM) has been made and OpenFOAM software has been adapted to include rodlike particles.

DISSERTATIONS

-

SCIENTIFIC PUBLICATIONS

-

PROJECT LEADERS

JT Padding

RESEARCH THEME

Complex dynamics of fluids

PARTICIPANTS

I Mema, JT Padding, B Fitzgerald, JAM Kuipers

COOPERATIONS

-

FUNDED

European Research Council (ERC)

University -

FOM -

STW -

NWO Other -

Industry -

TNO -

GTI -

EU 100 %

Scholarships -

START OF THE PROJECT

2015

INFORMATION

I Mema

I.Mema@tue.nl

DIRECT NUMERICAL SIMULATION OF PHASE TRANSITION IN DENSE BUBBLY FLOWS

PROJECT LEADERS

JAM Kuipers

RESEARCH THEME

Mathematical and computational methods for fluid flow analysis

PARTICIPANTS

H Mirsandi, EAJF Peters,

JAM Kuipers

COOPERATIONS

-

FUNDED

FOM, Akzo Nobel, DSM, Sabic, Shell and Tata Steel

University -

FOM 50 %

STW -

NWO Other -

Industry 50 %

TNO -

GTI -

EU -

Scholarships -

START OF THE PROJECT

2015

INFORMATION

H Mirsandi

06 12357452

h.mirsandi@tue.nl

PROJECT AIM

In many practical applications phase transition (evaporation and boiling) in dense bubbly flows occur. This phenomenon is very complex because of the interplay between flow and coupled mass and heat transport. In this project we will develop and employ Direct Numerical Simulation (DNS) technique to study dense bubbly flows with phase transition. Initially, we will focus on phase transition in single component systems but multi-component systems will be studied as well. The DNS code will be extended with multi-component transport equations and thermal energy equations to study respectively mass transfer and heat transfer at the micro scale.

PROGRESS

The project has been recently started in November, 2015. Currently, interface reconstruction procedure that can automatically and robustly model topology changes, such as interface breakup and merging, are being implemented into Front Tracking technique.

DISSERTATIONS

-

SCIENTIFIC PUBLICATIONS

-

MULTISCALE MODELLING OF DENSE GAS-FLUIDIZED FLOWS OF NON-SPHERICAL PARTICLES: HYDRODYNAMIC FORCES

PROJECT AIM

The objective is to pioneer a novel multiscale simulation methodology for dense gas-solid flows of non-spherical particles, based on systematic coarse-graining of interactions from small to larger scales, backed up by validating in-house experiments. As a first step, fully resolved direct numerical simulations (DNS) are to be performed to obtain the drag, lift and torque closures of suspensions containing elongated particles. Such particles are relatively simple, yet many of the fundamental problems linked to anisotropic drag and collisions already appear. The closures would later be used to perform discrete particle model simulations, which are in-turn validated with experiments.

PROGRESS

Currently, detailed investigations of different non-spherical particles are investigated in single particle configuration. Drag, lift and torque coefficients for such particles are calculated at different Reynolds number and different angles of attack with respect to the incoming flow. The results are compiled to produce necessary drag, lift and torque correlations for such particles.

DISSERTATIONS

-

SCIENTIFIC PUBLICATIONS

1. S.K.P. Sanjeevi, J.T. Padding, J.A.M. Kuipers (2015). Direct numerical simulations of fluid drag forces of non-spherical particle. The 11th International Conference on CFD in the Minerals and Process Industries, Melbourne, Australia, 7-9 December, 2015.

PROJECT LEADERS

JT Padding

RESEARCH THEME

Mathematical and computational methods for fluid flow analysis

PARTICIPANTS

SKP Sanjeevi, JT Padding,
JAM Kuipers

COOPERATIONS

-

FUNDED

European Research Council (ERC)

University	-
FOM	-
STW	-
NWO Other	-
Industry	-
TNO	-
GTI	-
EU	100 %
Scholarships	-

START OF THE PROJECT

2014

INFORMATION

SK Pacha Sanjeevi
040 247 8783
s.k.pacha.sanjeevi@tue.nl

DIRECT NUMERICAL SIMULATION OF MASS AND HEAT TRANSFER WITH CHEMICAL REACTION IN DENSE BUBBLY FLOWS

PROJECT LEADERS

JAM Kuipers

RESEARCH THEME

Mathematical and computational methods for fluid flow analysis

PARTICIPANTS

IA Panda, EAJF Peters, JAM Kuipers

COOPERATIONS

-

FUNDED

FOM, Akzo Nobel, DSM, Sabic Shell and Tata Steel

University -

FOM 50 %

STW -

NWO Other -

Industry 50 %

TNO -

GTI -

EU -

Scholarships -

START OF THE PROJECT

2015

INFORMATION

A Panda

06 85081920

a.panda@tue.nl

PROJECT AIM

In this project we propose to utilize Direct Numerical Simulation (DNS) techniques (i.e. Front Tracking (FT) combined with Immersed Boundary Techniques) to study and quantify the exchange of mass and heat in dense bubbly flows. Particular problem of interest is to resolve the concentration and temperature boundary layers which are of orders of magnitudes smaller than the hydrodynamic boundary layers. The in house DNS codes will be extended with species conservation equations and thermal energy equations to study respectively mass transfer and heat transfer (to immersed surfaces) at the micro scale. One of the systems that will be studied involves a high liquid density and a high surface tension, which is of particular interest to the field of bubbly flow in liquid metals. Traditionally such flows are studied by using water as a model fluid. However, apart from the temperature and pressure effects, liquid metals substantially differ from water in their wettability to ceramics, their density and surface tension. The DNS tools will enable us to investigate the behavioral differences between liquid metal and water. We will also consider cases with (predefined) bubble size distributions, starting from mono-disperse and bi-disperse systems.

PROGRESS

The project has been recently started in September 2015. A detailed literature survey about front tracking and ways to resolve multiscale transport phenomena has been presented and discussed. Current ongoing work includes way to couple the hydrodynamics solver which uses front tracking with convection diffusion equation on an adaptive grid which localizes the computational effort in areas of high gradient/error.

DISSERTATIONS

-

SCIENTIFIC PUBLICATIONS

-

INTERFACIAL DYNAMICS IN MULTIPHASE FLOW THROUGH POROUS ROCK

PROJECT AIM

The dynamics of interfaces in multiphase flow through porous media is complex. A novel CFD method based on Voronoi cells is proposed for the study of such multiphase flows. This enables investigation of supra-pore-scale mechanisms that determine the dynamics of oil in rock in secondary and surfactant-enhanced oil recovery. The method will be validated using in-house micro-fluidic experiments. The final goal is to perform large scale parallelized simulations of multiphase in digitized rock samples.

PROGRESS

A detailed literature survey has been carried out on Voronoi cells construction algorithms, geometric properties and different type of CFD solvers built on it. We have developed a compressible Lagrangian CFD solver validated it with basic test cases. We have also developed some models to accurately find the viscous forces on Voronoi grids. Current work involves the development of incompressible CFD solver using same approach. Simultaneously, we are also studying the consistency and convergence of discrete differential operators (gradients, divergence and Laplacian) on Voronoi grids.

DISSERTATIONS

-

SCIENTIFIC PUBLICATIONS

-

PROJECT LEADERS

EAJF Peters, JT Padding

RESEARCH THEME

Mathematical and computational methods for fluid flow analysis

PARTICIPANTS

H Patel, JAM Kuipers

COOPERATIONS

Shell

FUNDED

Shell, FOM	
University	-
FOM	50 %
STW	-
NWO Other	-
Industry	50 %
TNO	-
GTI	-
EU	-
Scholarships	-

START OF THE PROJECT

2015

INFORMATION

EAJF Peters
040 247 3122
E.A.J.F.Peters@tue.nl

DIRECT NUMERICAL SIMULATION OF BOILING HEAT TRANSFER IN MICROCHANNELS

PROJECT LEADERS

JAM Kuipers, CWM van der Geld,
JGM Kuerten

RESEARCH THEME

Mathematical and computational
methods for fluid flow analysis

PARTICIPANTS

A Rajkotwala, EAJF Peters,
JAM Kuipers, CWM van der Geld,
JGM Kuerten

COOPERATIONS

-

FUNDED

STW, Industrial partners
University -
FOM -
STW 75 %
NWO Other -
Industry 25 %
TNO -
GTI -
EU -
Scholarships -

START OF THE PROJECT

2015

INFORMATION

A Rajkotwala
06 33886096
a.rajkotwala@tue.nl

PROJECT AIM

To carry out meso-scale simulations of contactless and contactful boiling processes for controlled evaporation in microchannels. An inhouse 3D Front Tracking (FT) method will be extended to include phase transition. The resulting FT scheme will be modified to incorporate Diffuse Interface Model (DIM) as a dynamic sub-grid model to properly account for micro-scale effects (for e.g. bubble coalescence). Simulations of the proposed test cases (Figures 1 and 2) will be carried out and results will be validated against experimental data. Closure laws will be developed which will be utilized to set up engineering model for industrial partners.

PROGRESS

The project has been recently started in October, 2015. A detailed literature survey about front tracking schemes is carried out and modifications are proposed in the interface reconstruction procedure to facilitate simulation of interface coalescence and breakup.

DISSERTATIONS

-

SCIENTIFIC PUBLICATIONS

-

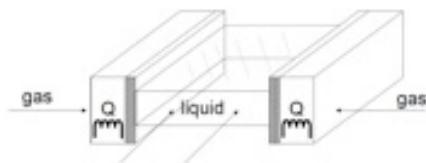

Schematic of Contactless boiling test section

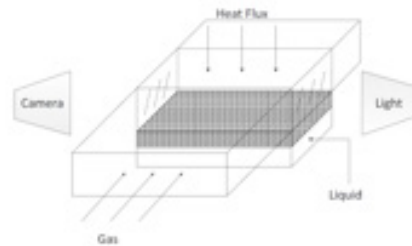

Schematic of Contactfull boiling test section

OPEN MICRO-STRUCTURED RANDOM PACKING IN GLS REACTORS FOR FISCHER-TROPSCH MULTI-SCALE REACTOR MODELLING

PROJECT AIM

The Fischer-Tropsch process is widely applied to convert a variety of resources, such as gas, biomass and coal, to fuels. The reactions in this process are very fast, which makes that transport to the catalyst, which performs the reaction, is often limiting the reaction rate. As a result, the process is not optimally efficient, but even worse, the product composition will deviate. In this project, we will design a new catalytic reactor with a very accessible structured solid foam catalyst, optimizing the transport properties on all length scales, from the nanometer scale of the active site where the reaction occurs up to the meter scale of the reactor itself.

PROGRESS

The project began on Oct 1 2015. Literature survey was done to understand heterogeneous catalysis in open structured catalysts. Currently working on 2 dimensional heat transfer using Immersed Boundary Methods.

DISSERTATIONS

-

SCIENTIFIC PUBLICATIONS

-

PROJECT LEADERS

JAM Kuipers

RESEARCH THEME

Mathematical and computational methods for fluid flow analysis

PARTICIPANTS

V Chandra, EAJF Peters, JAM Kuipers

COOPERATIONS

-

FUNDED

Netherlands Center for Multiscale Catalytic Energy Conversion (MCEC)

University	-
FOM	-
STW	-
NWO Other	100 %
Industry	-
TNO	-
GTI	-
EU	-
Scholarships	-

START OF THE PROJECT

2015

INFORMATION

V Chandra
06 33897154
v.chandra@tue.nl

Structuring a catalytic reactor for optimal performance:

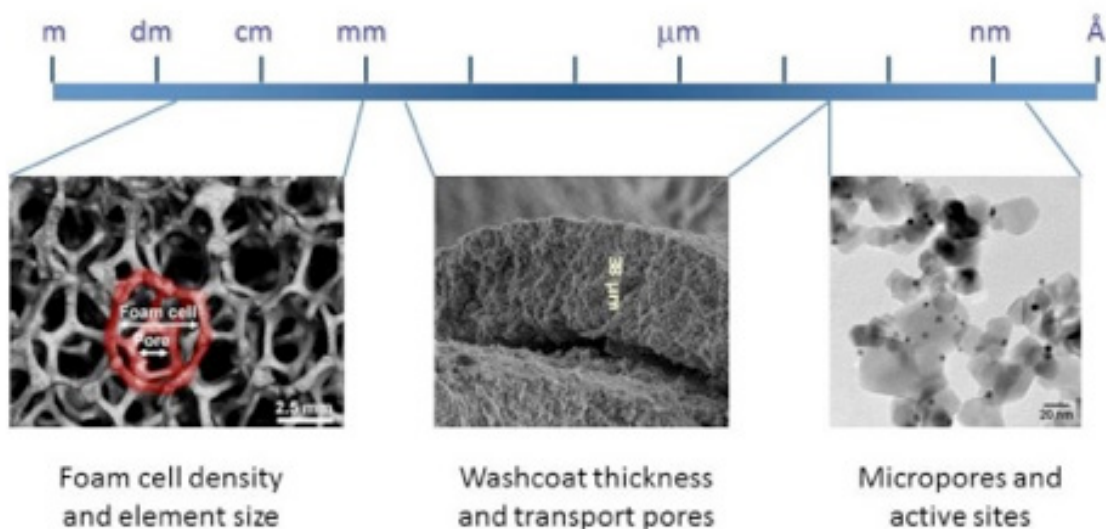

INFLUENCE OF WALL CORRUGATION ON MASS TRANSFER IN LIQUID CATALYTIC REACTORS

PROJECT LEADERS

JAM Kuipers, JT Padding, RA van Santen

RESEARCH THEME

Mathematical and computational methods for fluid flow analysis

PARTICIPANTS

A Sengar, JAM Kuipers, JT Padding, RA van Santen

COOPERATIONS

-

FUNDED

Netherlands Center Multiscale Catalytic Energy Conversion (MCEC)
University -
FOM -
STW -
NWO Other 100 %
Industry -
TNO -
GTI -
EU -
Scholarships -

START OF THE PROJECT

2015

INFORMATION

A Sengar
040 247 7321
a.sengar@tue.nl

PROJECT AIM

In many catalytic reactors, a liquid flow is used to enhance the mass transfer to and from catalytic sites dotted on solid surfaces. Solid surfaces are usually corrugated on length scales of micrometers. In this project we will perform a fundamental investigation of the coupled convection-diffusion-reaction mechanisms in the boundary layer near corrugated walls. This will lead to correlations for sub-grid-scale corrections to the mass transfer rates.

PROGRESS

A theoretical study of the new technique of Stochastic Rotation Dynamics has been done. A working code for this method of particle based simulations has been made and verified using some well-established results. Switching the diffusion coefficient of different solvents involved in catalytic reaction is currently being studied by switching the mass of the involved particles.

DISSERTATIONS

-

SCIENTIFIC PUBLICATIONS

-

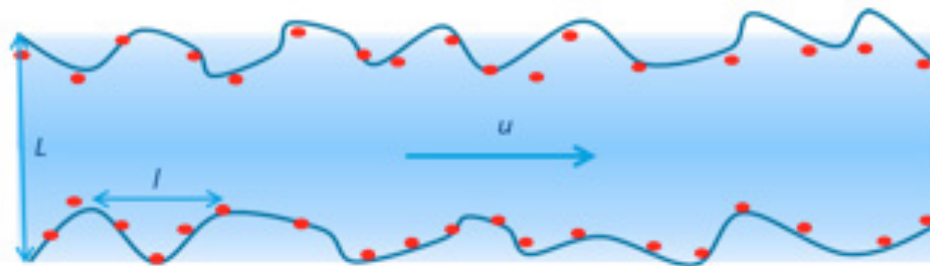

Wall corrugations at boundary layer.

MICRO-MECHANICS OF WET SOLIDS IN GAS-SOLID CONTACTORS

PROJECT AIM

This project is aimed at investigating the dynamic behavior of gas-particle processes involving liquid injection through a combined experimental and numerical study. Based on the detailed information obtained from the experiments and numerical simulations, we are able to identify the mechanisms of energy dissipation, sticking and transfer of mass and momentum during a collision of a wet particle, and to provide quantitatively descriptive closure equations that can be used in coarse-grained models.

PROGRESS

The numerical study of the mechanisms of wet particle collisions is conducted with the aid of a combined Volume of Fluid (VOF) / Immersed Boundary Method (IBM). This model allows us to describe, without any prior assumptions the dynamics of a particle colliding with a flat wall or another dry or wet particle. This model was thoroughly verified through a large set of different test cases for different multiphase flow systems (e.g. bubbly flow, slurry flow, bubbles interacting with a single wire and bubbles interacting with a wire mesh). Simulations of a spherical particle colliding with a solid wall covered by a thin liquid layer are performed. Figure 1 shows some example snapshots when collision occurs, and compares the velocity trajectories between simulation results and experimental measurements. A very good agreement is obtained with respect to the overall energy lost.

DISSERTATIONS

--

SCIENTIFIC PUBLICATIONS

-

PROJECTLEADERS

JAM Kuipers

RESEARCHTHEME

Complex dynamics of fluids

PARTICIPANTS

Y Tang, NG Deen, JAM Kuipers

COOPERATIONS

Prof.dir.-Ing.Habil. S. Heinrich

Ir. B. Crüger

FUNDED

STW, DFG

University -

FOM -

STW 100 %

NWO Other -

Industry -

TNO -

GTI -

EU -

Scholarships -

START OF THE PROJECT

2015

INFORMATION

JAM Kuipers

040 247 4158

j.a.m.kuipers@tue.nl

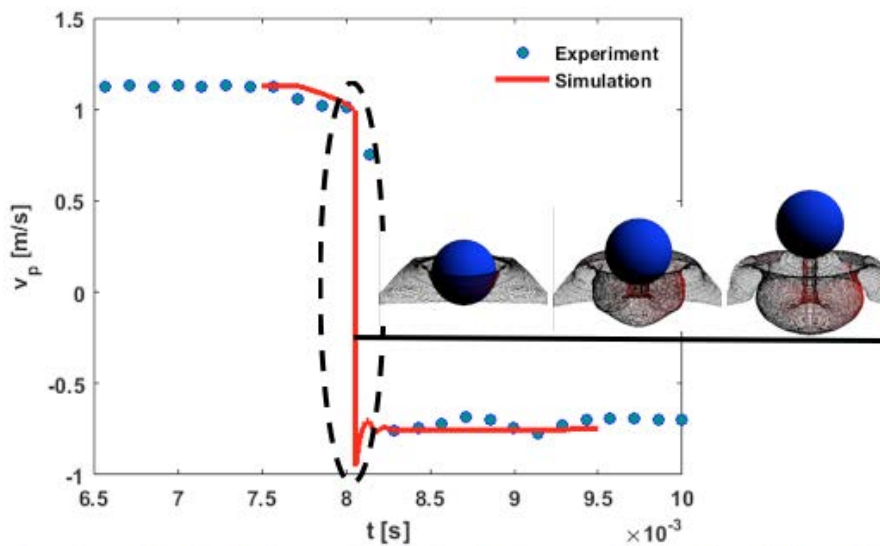

Trajectories of downwards velocity of a 1.74mm glass particle colliding with a wall covered by a 400µm layer of water. Snapshots are from the simulation



Prof.dr. WJ Briels

The Computational BioPhysics group (CBP) at the University of Twente is interested in the rheological and thermodynamical properties of complex soft matter. Typical multiphase systems being studied include dispersions of hard particles, e.g. spherical colloids or rod-like fd viruses, dispersed in Newtonian and non-Newtonian liquids. Close to equilibrium, the rheological properties are determined by the structural properties of the dispersed phase. Since these structures are usually stabilized by free energies in the order of several kT , they can easily be perturbed by applying flow gradients, which thus give rise to flow-induced modifications of the rheological properties. Well known phenomena resulting from this interplay between structure and flow are shear thinning, shear banding and temporal oscillations of optical and rheological properties in liquid crystalline polymer solutions. Self-assembly plays an important role in a number of systems being studied, ranging from surfactant-based worm-like micelles and lipid bilayers to various proteins that form neatly ordered structures, e.g. fibers and cages, or merely aggregate into disordered protein plaques. We are also interested in the rheology of linear and branched polymers, and the role played herein by entanglements.

The tools that we use belong to the field of particle based computer simulations. Since a full description of the observed phenomena requires a multi-scale approach, our simulation methods range from Molecular Dynamics (MD) and Monte Carlo (MC) to Multi Particle Collision Dynamics (MPCD) and Brownian Dynamics (BD). Detailed atomistic simulations are used to calculate the free energies that constitute the main interactions in subsequent simulations at a mesoscopic level. Our main strength is in developing new methods for (highly) coarse-grained simulations. We have, for instance, developed the twentanglement algorithm to investigate entangled melts of linear and branched polymers, introduced event-driven BD algorithms to simulate colloidal suspensions, developed Responsive Particle Dynamics (RaPiD) to study the flow properties of several non-linear fluids, and extended the patchy-particle approach to non-spherical particles to simulate self-assembly of protein clusters.

A SINGLE-MOLECULE VIEW ON PROTEIN AGGREGATION – SIMULATIONS OF ALPHA-SYNUCLEIN AGGREGATE FORMATION

PROJECT AIM

The ambition of this program is to unravel the physical mechanisms that underlie the dynamics of nucleation and formation of early aggregate species. To gain insight we are developing a novel highly coarse-grain modeling technique, specifically aimed at the secondary and tertiary structure of proteins, to simulate and explore the formation and structure of alpha-synuclein aggregates.

PROGRESS

We have developed a highly coarse-grained model by representing consecutive protein sequences of 10 to 15 aminoacids as soft rigid bodies with attractive patches on their surfaces. To simulate dynamics we have implemented a Brownian Dynamics algorithm for the translational and the rotational motion. We have combined it with patchy particles models allowing generic isotropic and directional patch-patch interactions. We have implemented this method for the self assembly of proteins into fibrillar structures. To determine conformational dynamics and inter-molecular binding energies we are performing all atom simulations of small fragments of alpha-synuclein.

DISSERTATIONS

1. I.M. Ilie, Chameleon behavior of alpha-synuclein. Brownian Dynamics Simulations of Protein Aggregation – PhD Disseration (December 2015).

SCIENTIFIC PUBLICATIONS

1. I.M.Ilie, W.J. Briels and W.K. den Otter, An elementary singularity free Rotational Brownian Dynamics algorithm for anisotropic particles, *J. Chem. Phys.* 142, 114103 (2015).

PROJECTLEADERS

WJ Briels

RESEARCHTHEME

Complex structures of fluids

PARTICIPANTS

IM Ilie

COOPERATIONS

WK den Otter, NFA van der Vegt

FUNDED

FOM	
University	-
FOM	100 %
STW	-
NWO Other	-
Industry	-
TNO	-
GTI	-
EU	-
Scholarships	-

START OF THE PROJECT

2011

INFORMATION

WJ Briels
w.j.briels@utwente.nl

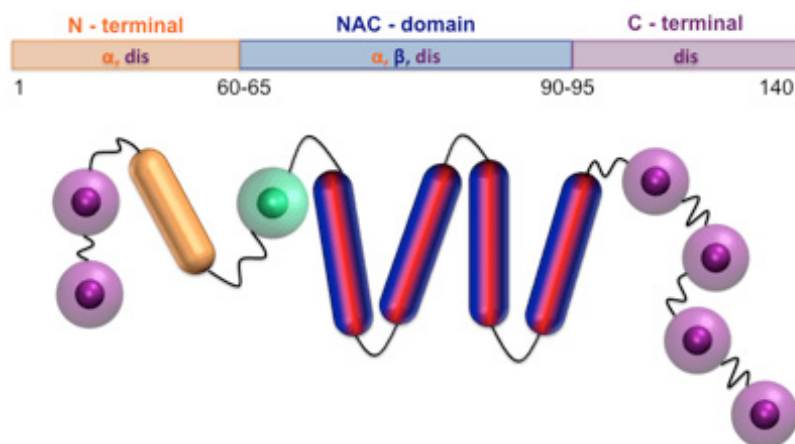

PARTICLE-BASED SIMULATIONS OF SINGLE-PHASE AND MULTI-PHASE NON-NEWTONIAN FLOW THROUGH POROUS MEDIA

PROJECT LEADERS

WJ Briels, J van der Gucht

RESEARCH THEME

Complex dynamics of fluids

PARTICIPANTS

VR Ahuja

COOPERATIONS

Interaction and data exchange with Shell Research Centres

FUNDED

Shell - NWO / FOM Programme: 'Computational Sciences for Energy Research' (CSER)

University	-
FOM	50 %
STW	-
NWO Other	-
Industry	50 %
TNO	-
GTI	-
EU	-
Scholarships	-

START OF THE PROJECT

2013

INFORMATION

WJ Briels
w.j.briels@utwente.nl

J van der Gucht
jasper.vandergucht@wur.nl

PROJECT AIM

The aim of this project is to study flow of non-Newtonian fluids through porous media using particle-based simulation technique that can handle soft matter systems with spatial and temporal memory in complex geometries. This is relevant for example in polymer flooding application which is an Enhanced Oil Recovery (EOR) technique where a small amount of polymer is added to the injection water to modify its flow properties leading to viscoelastic effects thereby improving the volumetric sweep efficiency in the oil reservoir.

PROGRESS

We have used Responsive Particle Dynamics (RaPiD)[1] to model FLOPAAM, a polymer solution used in Enhanced Oil Recovery (EOR) to match the experimental data of loss and storage moduli for the polymer solution. We have also validated our model by comparing the prediction of non-linear dynamics viz. the shear thinning behavior of the polymer solution from the model vis-a-vis the experimental data. Furthermore, we have developed a technique to study the flow of highly frictional soft matter fluids in the bulk and in the presence of solid interfaces. This technique is based on a modified version of a Galilean invariant two-way coupling algorithm[2] which couples the coarse-grained co-ordinate motion of the polymer molecules with the flow of the background fluid implicitly present in the coarse-grained simulation technique. We have incorporated the effect of a solid boundary by using a technique which involves incorporating artificial particles into the wall which offer 'friction' to the flow of the background fluid thereby imposing the no-slip boundary condition at the solid-fluid interface.[3,4].

DISSERTATIONS

-

SCIENTIFIC PUBLICATIONS

1. Briels, W. J. (2009). Transient forces in flowing soft matter. *Soft Matter*, 5(22), 4401-4411.
2. Padding, J. T., & Briels, W. J. (2014). Momentum conserving Brownian dynamics propagator for complex soft matter fluids. *The Journal of chemical physics*, 141(24), 244108.
3. Morris, J. P., Fox, P. J., & Zhu, Y. (1997). Modeling low Reynolds number incompressible flows using SPH. *Journal of computational physics*, 136(1), 214-226.
4. Ahuja, V. R., van der Gucht, J., Briels, W. J., Coarse-grained simulations for flow of complex soft matter fluids in the bulk and in the presence of solid interfaces. Submitted.

SELF-ASSEMBLY OF PROTEIN COATS AT MEMBRANES

PROJECT AIM

The main objective of this study is to explore and characterize the assembly process of clathrin-coated cages against the cytosolic surface of a cellular membrane and the role of other proteins such as adaptor proteins (APs). This is accomplished through Monte Carlo and Brownian Dynamics simulations using highly coarse-grained protein and membrane models, and through a statistical mechanical description of the assembly process.

PROGRESS

A coarse-grained simulation model for Aps and membranes was developed to study the AP-induced self-assembly of clathrin into cages both in bulk and near a surface. A complementary theoretical framework was also developed. The results of both approaches are in line with the available experimental data, and provide a better understanding of how and under which conditions APs regulate and control the assembly of cages. The study also revealed the intrinsically cooperative nature of the self-assembly process.

DISSERTATIONS

-

SCIENTIFIC PUBLICATIONS

-

PROJECT LEADERS

WJ Briels

RESEARCH THEME

Complex structures of fluids

PARTICIPANTS

MGiani

COOPERATIONS

WK den Otter

FUNDED

NWO

University -

FOM -

STW -

NWO Other 100 %

Industry -

TNO -

GTI -

EU -

Scholarships -

START OF THE PROJECT

2012

INFORMATION

WJ Briels

w.j.briels@utwente.nl



PHYSICS OF FLUIDS



Prof.dr. D Lohse



Prof.dr.ir. D van der Meer



Prof.dr.ir. J Snoeijer



Prof.dr. J Harting



Prof.dr. X Zhang

The Physics of Fluids group in Twente works on a variety of aspects in fluid mechanics, in particular on those related to bubbles. The focus of our work is the fundamental understanding the phenomena of the physics of fluids, bubbles and jets, which we undertake by experimental, numerical and theoretical means. Besides in the J.M.Burgers Center, our research is embedded in the Research Institute of Mechanics, Processes and Control IMPACT, the MESA+ Institute, and the Research Institute for Biomedical Technology BMTi of the University of Twente. The group receives external research funds mainly from FOM, but also from STW, NWO, SenterNovem, EU and several companies. The focus research areas of the group are:

TURBULENCE AND TWO-PHASE FLOW

Fully developed turbulence is one of the big unsolved problems in fluid dynamics. The main question is the distribution of rare events, which has important implications for, e.g., flight safety. We approach this problem from a fundamental point of view, both experimentally, theoretically, and numerically. One particular important type of turbulence is turbulence (partly) driven by body forces, such as buoyancy. This can happen by either thermally driving the turbulence or also by driving the turbulence through bubbles or dispersed particles. Both will be advected by the flow but also act back on the surrounding liquid (two-way coupling). To be able to describe flow with many bubbles or particles efficiently, one needs an effective force description, on which and with which we work in several projects within our group. Finally, we are also interested in the radial dynamics of single bubbles in hydrodynamic or acoustic fields.

GRANULAR FLOW

Granular flows are fundamentally different from any other type of flow. In our research we focus on the clustering phenomenon that finds its origin in the inelastic collisions between the particles. There is much emphasis on the onset of clustering, which happens via a phase transition which is studied in both compartmentalized and continuous systems. Another line of our research deals with the impact of objects on very fine, decompactified sand, in which we explore the applicability of fluid models to granular systems. We uncovered links to distant phenomena like asteroid impact and a dry variety of quicksand.

MICRO- AND NANOFUIDICS

The physics of fluids at the microscale can be quite different from macrofluidic behavior. Here we study disturbing bubbles in microchannels found in ink jet printing. By patterning surfaces on sub-micron scales we try to identify individual 'nanobubbles' which may lead to a quantitative understanding of wall slip. These patterned surfaces may also serve as nucleation sites for cavitation bubbles generated through intense negative pressures.



Prof.dr. JF Dijkstra



Prof.dr.ir. L van Wijngaarden



Prof.dr. A Prosperetti



Prof.dr. R Verzicco

BIOMEDICAL FLOW

Bubbles have various applications in the biomedical field. Coated microbubbles are used in ultrasound imaging to enhance the contrast in cardiac or liver perfusion images. Bubbles can be targeted to specific cells for molecular imaging to non-invasively detect the presence and location of diseases such as cancer or atherosclerosis. Furthermore, the bubbles can be exploited to generate acoustic streaming and jetting near cell boundaries which leads to permeation, destruction or removal of target cells.



TURBULENT TAYLOR-COUPETTE FLOW

PROJECT AIM

Skin drag reduction in the naval transport, being the largest carrier of freight in the world, is of large environmental importance as this diminishes the fuel consumption. The practical concept is to create air lubrication alongside the hull of the ship, by injecting bubbles into the boundary layer. Several laboratory experiments easily result in drag reductions of 20% and above. However, application on real life ships barely results in 5%. A solid understanding of the bubble mechanism leading to drag reduction is still missing. To investigate the mechanism behind bubbly skin drag reduction, our group has designed a state-of-the-art turbulent two-phase Taylor-Couette setup. Two independently rotating cylinders, with a fluid in between the gap, comprise a closed and energy balanced system.

PROGRESS

- A second Taylor-Couette facility has been manufactured. In this device we will also study the behaviour of boiling in turbulent flows.
- Two new PhD students had started in January
- For the older Taylor-Couette, a new inner cylinder has been constructed, in which it is possible to study roughness and air layers.
- Several studies are performed, and are expected to be published within months. Topics include: decay of turbulent flows, multiple states, TC flow at radius ration=0.5.

DISSERTATIONS

-

SCIENTIFIC PUBLICATIONS

1. Azimuthal velocity profiles in Rayleigh-stable Taylor-Couette flow and implied axial angular momentum transport. F. Nordsiek, S.G. Huisman, R.C.A. van der Veen, C. Sun, D. Lohse, and D.P. Lathrop. *J. Fluid Mech.* 774, 342– (2015).
2. The boiling Twente Taylor-Couette (BTTC) facility: Temperature controlled turbulent flow between independently rotating, coaxial cylinders. S.G. Huisman, R.C.A. van der Veen, G.W.H. Bruggert, D. Lohse, and C. Sun. *Rev. Sci. Instrum.* 86, 065108 (2015).
3. Logarithmic Mean Temperature Profiles and Their Connection to Plume Emissions in Turbulent Rayleigh-Bénard Convection. E.P. van der Poel, R. Ostilla Mónico, R. Verzicco, S. Grossmann, and D. Lohse. *Phys. Rev. Lett.* 115, 154501 (2015).
4. Salinity transfer in bounded double diffusive convection. Y. Yang, E.P. van der Poel, R. Ostilla Mónico, C. Sun, R. Verzicco, S. Grossmann, and D. Lohse. *J. Fluid Mech.* 768, 476–491 (2015).
5. Effects of the computational domain size on direct numerical simulations of Taylor-Couette turbulence with stationary outer cylinder. R. Ostilla Mónico, R. Verzicco, and D. Lohse. *Phys. Fluids* 27, 025110 (2015).
6. Inertial waves and mean velocity profiles in a rotating pipe and a circular annulus with axial flow. Y. Yang, R. Ostilla Mónico, J. Wu, and P. Orlandi. *Phys. Rev. E* 91, 013015 (2015).
7. A multiple-resolution strategy for Direct Numerical Simulation of scalar turbulence. R. Ostilla Mónico, Y. Yang, E.P. van der Poel, D. Lohse, and R. Verzicco. *J. Comput. Phys.* 301, 308 – 321 (2015).
8. A pencil distributed finite difference code for strongly turbulent wall-bounded flows. E.P. van der Poel, R. Ostilla Mónico, J. Donners, and R. Verzicco. *Computers & Fluids* 116, 10 – 16 (2015).

PROJECT LEADERS

D Lohse, C Sun

RESEARCH THEME

Complex dynamics of fluids

PARTICIPANTS

D Bakhuis, R van der Veen, R Verschoof, R Ezeta, S Huisman (until August 2015)

COOPERATIONS

Damen Shipyards, Marin, Akzonobel

FUNDED

STW, FOM, NWO	
University	-
FOM	50 %
STW	25 %
NWO Other	25 %
Industry	-
TNO	-
GTI	-
EU	-
Scholarships	-

START OF THE PROJECT

2011

INFORMATION

C Sun
053 489 5604
c.sun@utwente.nl
<http://pof.tnw.utwente.nl/research/turbulencebubbles/bubbledragreduction>

INKJET PRINTING OF SUSPENSIONS

PROJECT LEADERS

D Lohse, JH Snoeijer, JF Dijkstra

RESEARCH THEME

Complex dynamics of fluids

PARTICIPANTS

MJ Thoraval, E Sandoval

COOPERATIONS

Holst Center, Dutch Polymer Institute

FUNDED

Holst Center, Dutch Polymer Institute

University -

FOM -

STW -

NWO Other -

Industry 50 %

TNO 50 %

GTI -

EU -

Scholarships -

START OF THE PROJECT

2012

INFORMATION

D Lohse

053 489 8076

d.lohse@utwente.nl

pof.tnw.utwente.nl

PROJECT AIM

Inkjet printing is considered the contender of choice for the manufacturing of low-cost and large-area electronics, such as for disposable medical devices; radio-frequency applications for theft protection in shops, polymer LED based lighting devices, or solar cells. The idea is to make these devices on roll-to-roll equipment: the components of the electronic structures are deposited by means of inkjet printing, which can be scaled to any deposition rate by adding either extra nozzles or extra print heads and to adjust the droplet volume.

PROGRESS

- Explore the possibility of using jetting as a rheometer. Indeed, the high shear rates encountered in the jetting are not accessible with conventional rheometers.
- Investigate the splashing – non-splashing transition of silver nano-suspension when increasing the droplet impact velocity. This behavior is very surprising and was not reported before. It will help us understand the physics of splashing.
- Analyze the behavior of non-axisymmetric droplets and potentially determine their shape, volume and local velocity field, by means of coupled high speed imaging techniques.

DISSERTATIONS

-

SCIENTIFIC PUBLICATIONS

-

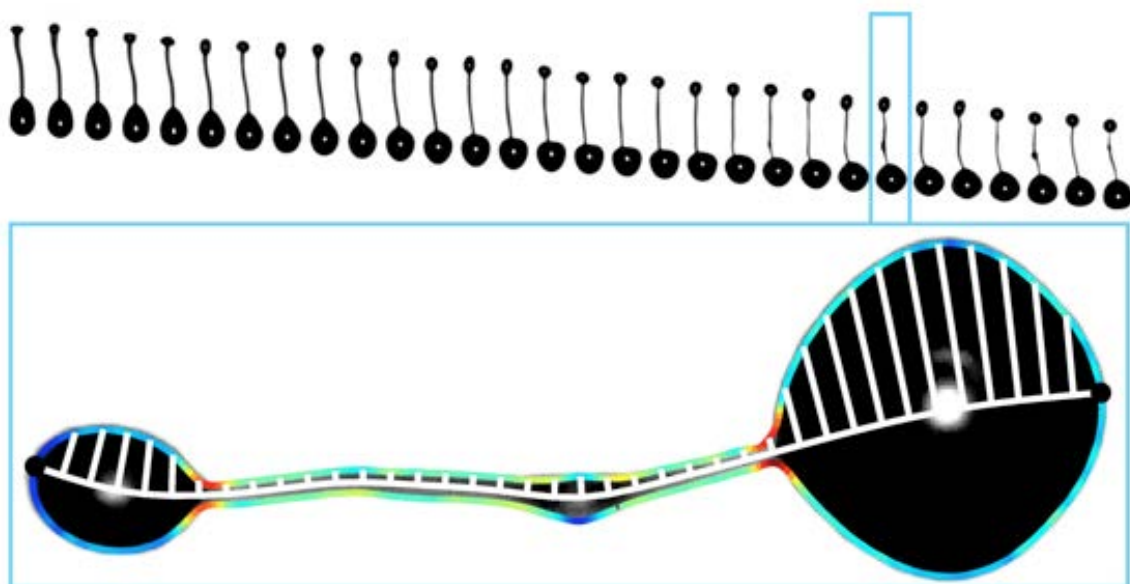

THE ROLE OF VAPOR/AIR LAYER IN DROPLET-SURFACE INTERACTIONS

PROJECT AIM

(1) To study the air entrainment and splashing processes of impacting droplet on various kinds of surfaces: smooth solid surfaces, micro-structured solid surfaces, solid surfaces covered by a thin liquid film, liquid surfaces.

(2) To study the boiling and hydrodynamic processes of liquid droplets on superheated surfaces, in particular, the role of the vapour layer in affecting the spreading and boiling behaviours of droplets..

PROGRESS

Highlights:

- Laser total internal reflection method to measure the wetting on heated substrates under impacting droplets.
- Study of dynamic Leidenfrost temperature for various thermal conducting materials.
- Splashing threshold and mechanism of impacting Leidenfrost droplet.
- Fragmentation of droplet in the contact boiling regime.

DISSERTATIONS

-

SCIENTIFIC PUBLICATIONS

1. Staat, Hendrik JJ, et al. "Phase diagram for droplet impact on superheated surfaces." *Journal of fluid mechanics* 779 (2015): R3.

PROJECTLEADERS

D Lohse, C Sun

RESEARCHTHEME

Complex dynamics of fluids

PARTICIPANTS

MAJ van Limbeek, D Lohse, A Prosperetti, M Shirota, HJJ Staat, C Sun

COOPERATIONS

-

FUNDED

FOM	
University	-
FOM	100 %
STW	-
NWO Other	-
Industry	-
TNO	-
GTI	-
EU	-
Scholarships	-

START OF THE PROJECT

2011

INFORMATION

D Lohse
053 489 8076
d.lohse@utwente.nl
pof.tnw.utwente.nl

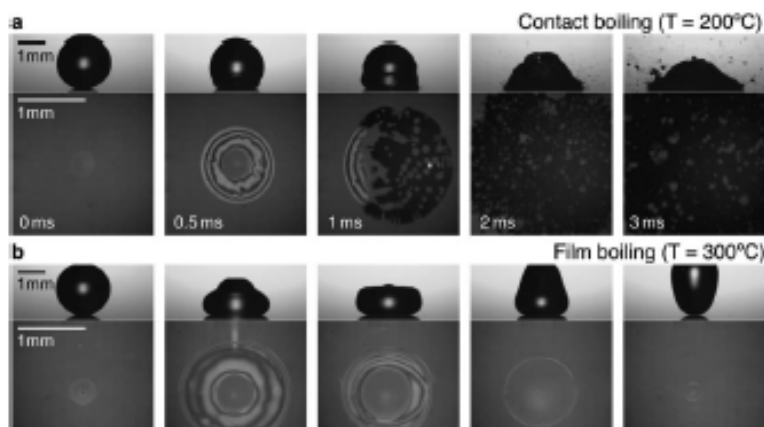

Representative series of snapshots during impact taken from the side and the bottom-views showing spreading and boiling processes of droplet impact on a smooth sapphire surface in (a) contact boiling regime, and (b) film boiling regime.

SUPERSONIC MICROJETS

PROJECT LEADERS

D Lohse, C Sun

RESEARCH THEME

Complex dynamics of fluids

PARTICIPANTS

CW Visser

COOPERATIONS

LAM research, Austria;
Georg August Universität, Göttingen;
Developmental BioEngineering
group, UT. R. Pohl, G.R.B.E. Römer,
A.J. Huis in 't Veld, H.B.J. Karperien.

FUNDED

FOM	
University	-
FOM	100 %
STW	-
NWO Other	-
Industry	-
TNO	-
GTI	-
EU	-
Scholarships	-

START OF THE PROJECT

2011

INFORMATION

D Lohse
053 489 8076
d.lohse@utwente.nl
pof.tnw.utwente.nl

PROJECT AIM

- (1) To study and optimize the generation of extremely fast laser-induced microjets;
- (2) Study the impact of these jets and the impact of jet-generated droplets.
- (3) To bio-print cell-containing materials in novel morphologies.

PROGRESS

- Several publications were accepted in leading journals.
- The article in *Advanced Materials* received widespread media attention, which resulted in the UT media prize for C.W. Visser.
- These and previous results strongly contributed to the Rubicon grant that was awarded to Visser, for a 2-year stay at Harvard University, MA, USA.

DISSERTATIONS

1. Fundamental and applications of fast micro-drop impact, Claas Willem Visser, 2014.

SCIENTIFIC PUBLICATIONS

1. Hendriks, J. et al. Optimizing cell viability in droplet-based cell deposition. *Sci. Rep.* 5, 11304 (2015).
2. Visser, C. W. et al. Toward 3D Printing of Pure Metals by Laser-Induced Forward Transfer. *Adv. Mater.* 27, 4103–4108 (2015).
3. Pohl, R. et al. Ejection Regimes in Picosecond Laser-Induced Forward Transfer of Metals. *Phys. Rev. Appl.* 3, 024001 (2015).
4. Klein, A. L. et al. Drop shaping by laser-pulse impact. *Phys. Rev. Appl.* 3, 044018 (2015).
5. Visser, C. W. et al. Quantifying Cell Adhesion through Impingement of a Controlled Microjet. *Biophys. J.* 108, 23–31 (2015).

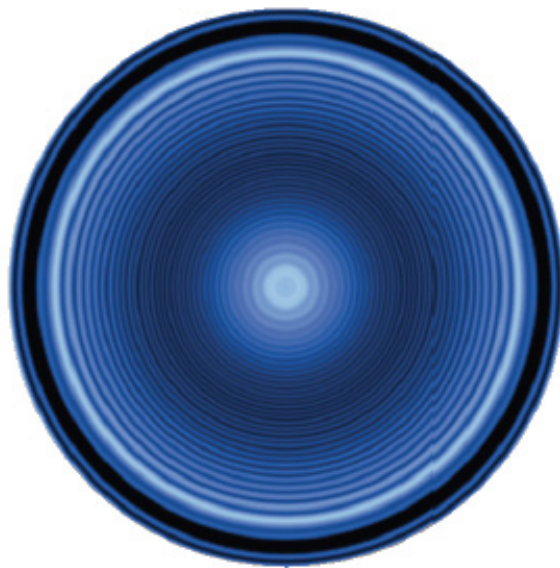
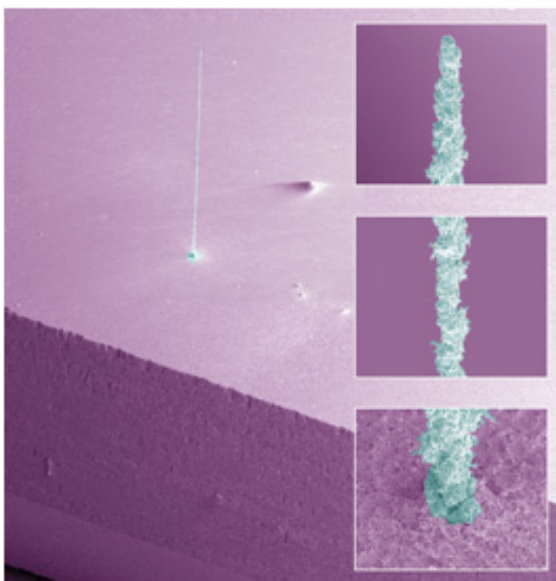

(1) LINE TENSION AND WETTABILITY OF NANODROPS ON CURVED SURFACES AND (2) GROWTH AND DISSOLUTION OF SURFACE NANOBUBBLES

PROJECT AIM

1 a) To study the wettability of nanodrops on curved surface with the help of MD simulations.

1 b) To calculate the line tension of Lenard-Jones (LJ) nanodrop as a function of surface curvature.

2 a) To show that pinning of the contact line and oversaturation of gas in liquid are prerequisites for stable nanobubbles.

2 b) To find out the growth and dissolution mechanism of surface nanobubble on a chemical heterogeneous surface.

PROGRESS

1) We have done MD simulations of LJ nanodrops on curved surfaces in quasi-2D and 3D and calculated wettability and line tension of nanodrops as a function of surface curvature.

2) We have shown with the help of MD simulations that pinning and oversaturation of gas leads to the stable surface nanobubbles. We have studied the bubble dissolution dynamics

and showed the “stick-jump” mechanism of the three-phase contact line which was also observed experimentally in case of dissolution of micro-drops.

DISSERTATIONS

-

SCIENTIFIC PUBLICATIONS

1. Maheshwari, Shantanu, Martin van der Hoef, and Detlef Lohse. “Line tension and wettability of nanodrops on curved surfaces.” *Langmuir* (2015).

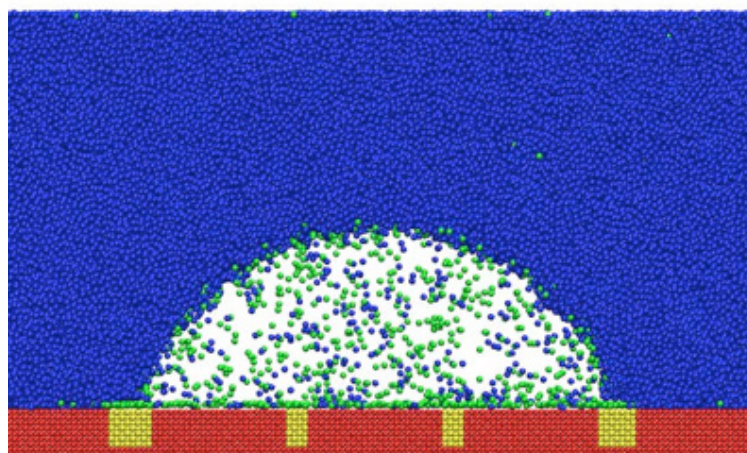
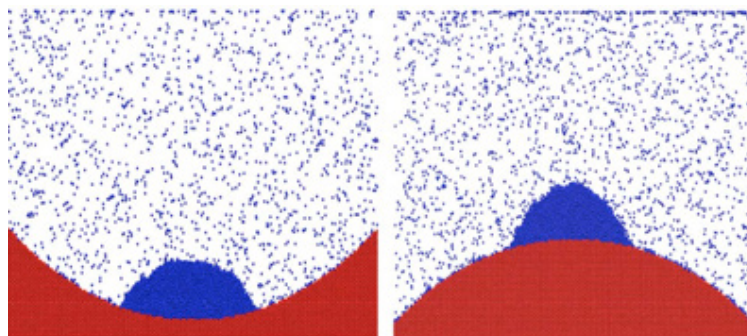

PROJECTLEADERS

D Lohse, M van der Hoef

RESEARCHTHEME

Complex dynamics of fluids

PARTICIPANTS

S Maheshwari

COOPERATIONS

-

FUNDED

FOM

University

FOM 100 %

STW

NWO Other

Industry

TNO

GTI

EU

Scholarships

START OF THE PROJECT

2014

INFORMATION

D Lohse

053 489 8076

d.lohse@utwente.nl

pof.tnw.utwente.nl.

SURFACE NANOBUBBLES: BENEFITS AND HINDERANCE

PROJECT LEADERS

D Lohse, HJW Zandvliet

RESEARCH THEME

Complex dynamics of fluids

PARTICIPANTS

ES Kooij, E Dietrich

COOPERATIONS

-

FUNDED

NWO

University -

FOM -

STW -

NWO Other 100 %

Industry -

TNO -

GTI -

EU -

Scholarships -

START OF THE PROJECT

2012

INFORMATION

E Dietrich

e.dietrich@utwente.nl

PROJECT AIM

To study the behavior and properties of interfacial nano- and microbubbles and droplets at solid liquid interfaces.

PROGRESS

The studies on dissolving sessile droplets were taken further by detailed measurements on the influence of pinning of the contact line on the dissolution process, the effect of convection on the dissolution. Also, more complex systems have been studied, including patterns of multiple droplets, and droplets consisting on mixtures of various liquids.

DISSERTATIONS

-

SCIENTIFIC PUBLICATIONS

1. Berkelaar, R.P., Bampoulis, P., Dietrich, E., Jansen, H.P., Zhang, Xuehua, Kooij, E.S., Lohse, D. & Zandvliet, H.J.W. (2015). Water induced blister formation in a thin film polymer. *Langmuir*, 31, 1017-1025.
2. Zhang, X., Wang, J., Bao, L., Dietrich, E., Veen, R.C.A. van der, Peng, S., Friend, J., Zandvliet, H.J.W., Yeo, L. & Lohse, D. (2015). Mixed mode of dissolving immersed nanodroplets at a solid-water interface. *Soft Matter*, 11(10), 1889-1900.
3. Dietrich, E., Kooij, E.S., Zhang, X., Zandvliet, Harold J.W. & Lohse, D. (2015). Stick-Jump Mode in Surface Droplet Dissolution. *Langmuir*, 31, 4696-4703.

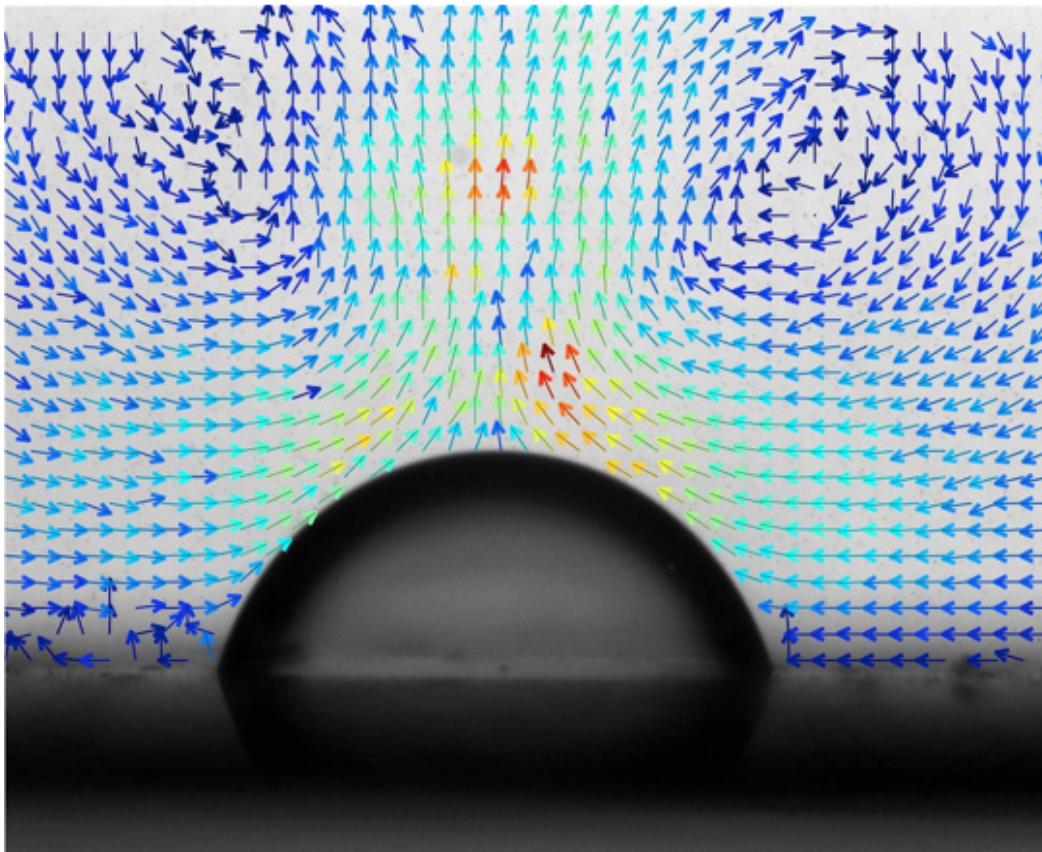

FLUID DYNAMICS IN EUV SOURCES & NOZZLES FOR NON-CIRCULAR JET BREAKUP

PROJECT AIM

The aim of the project is to provide fundamental understanding of fluid dynamics in EUV sources and nozzles in general in order to increase the conversion efficiency of the next generation lithography machines. Topics of this work include droplet generation, coalescence dynamics, target shaping, plasma droplet interaction, interaction of gas flows with droplet trajectory, process stability and splashing. The project has an experimental focus, supported by theory and numerical modeling.

PROGRESS

Current work focuses on drop impact on a deep pool for low Bond numbers. The work is currently written down.

DISSERTATIONS

-

SCIENTIFIC PUBLICATIONS

-

Current work in the area of nozzles focuses on the breakup of non-circular jets. This work is in the process of being formed into an article.

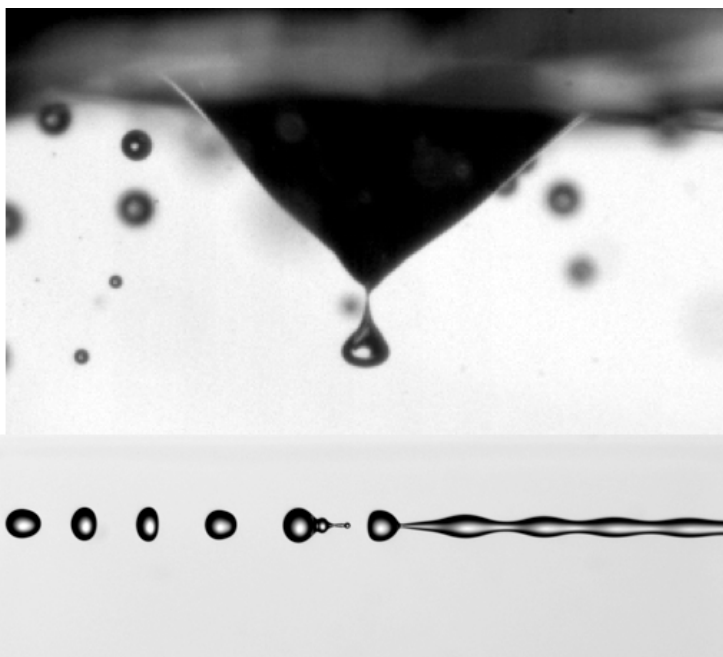

PROJECTLEADERS

D Lohse, M Versluis

RESEARCHTHEME

Complex dynamics of fluids

PARTICIPANTS

P Sleutel, M Kok

COOPERATIONS

Ben de Smet, Michel Riepen (ASML), Herman Wijshof (Oce, NanonextNL), Jeroen Wissink (Medspray)

FUNDED

NanonextNL	
University	-
FOM	-
STW	-
NWO Other	100 %
Industry	-
TNO	-
GTI	-
EU	-
Scholarships	-

START OF THE PROJECT

2012

INFORMATION

P Sleutel
053 489 4213
c.p.sleutel@utwente.nl

Maarten Kok
053 489 3084
<http://pof.tnw.utwente.nl>

ACTIVATION, ACTUATION AND MANIPULATION OF ULTRASOUND CONTRAST AGENT

PROJECT LEADERS

M Versluis, N de Jong

RESEARCH THEME

Complex dynamics of fluids

PARTICIPANTS

G Lajoinie, T Segers

COOPERATIONS

Rotterdam Erasmus MC, Ghent University, Nanomi (Oldenzaal), Oxford University, Radboud UMC Nijmegen, University of Sevilla, University of Toronto, Bracco(Geneva)

FUNDED

NanoNextNL	
University	-
FOM	-
STW	-
NWO Other	100 %
Industry	-
TNO	-
GTI	-
EU	-
Scholarships	-

START OF THE PROJECT

2011

INFORMATION

M Versluis
053 489 6824
m.versluis@utwente.nl
<http://pof.tnw.utwente.nl/people/profile/23>
http://stilton.tnw.utwente.nl/people/michel/Michel_Versluis/Home.html

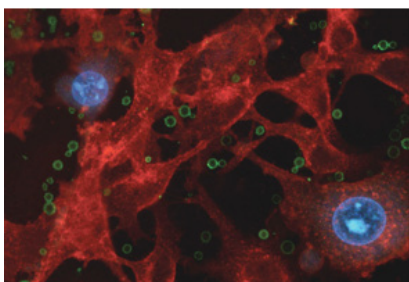

PROJECT AIM

This project aims at developing the next generations of contrast agents for ultrasound and photoacoustic imaging and therapy. This is achieved in first place by developing new designs based on an innovating use of physical phenomena. The corresponding production and/or sorting methods are then investigated and optimized. Finally, the project also aims at assessing the potential of these agent in an in vitro setting.

PROGRESS

The manipulation of commercially available microbubbles was shown to boost their contrast capability by a factor 20. This increase also opened interesting opportunities for making use of the fine physical specificities of microbubbles. Made more efficient, these agents also demonstrated their capability in carrying and selectively releasing a payload. This project also proposed a first physical explanation based on microscale flows. Another class of agents involving phase change of fluids, triggered by either acoustics or light was extensively studied. On one hand, significant advances were made in understanding the physics of acoustic vaporization by means of high frequency surface waves. On the other hand, microsized light absorbing capsules loaded with low boiling point fluids have shown their potential for optoacoustics, owing to the strong acoustic generation associated with explosive vaporization.

DISSERTATIONS

1. Monodispersed bubbles and droplets for medical applications, Tim Segers, 2015.
2. Ultrasound contrast agents: bubbles, drops and particles, Guillaume Lajoinie, 2015.

SCIENTIFIC PUBLICATIONS

1. Bubble sorting in pinched microchannels for ultrasound contrast agent enrichment. Maarten P. Kok, Tim Segers, and Michel Versluis. *Lab Chip* 15, 3716-3722 (2015).
2. Microbubbles for Medical Applications. Tim Segers, Nico de Jong, Detlef Lohse, and Michel Versluis. in 'Microfluidics for Medicine'. Albert van den Berg and Loes Segerink (Editors). RSC Nanoscience and Nanotechnology Series. ISBN: 978-1-84973-637-4, The Royal Society of Chemistry (2015).
3. Impulse response method for characterization of echogenic liposomes. Jason L. Raymond, Ying Luan, Tom van Rooij, Klazina Kooiman, Shao-Ling Huang, David D. McPherson, Michel Versluis, Nico de Jong, and Christy K. Holland. *J. Acoust. Soc. Am.* 137, 1693-1703 (2015).
4. Nonlinear response and viscoelastic properties of lipid-coated microbubbles: DSPC vs. DPPC. Tom van Rooij, Ying Luan, Guillaume Renaud, Antonius F.W. van der Steen, Michel Versluis, Nico de Jong, and Klazina Kooiman. *Ultrasound Med. Biol.* 41, 1432-1445 (2015).

FLUCTUATIONS NEAR THE ONSET OF GRANULAR BUOYANCY-DRIVEN CONVECTION

PROJECT AIM

The main objective of this project is an experimental study of “Fluctuations near the onset of granular buoyancy-driven convection”. In this project the specific aim is provide greater clarity to the granular convection problem, quantifying the effects that appear in vibrated granular media. To reach this aim, we study experimentally un vibrated granular bed confined in an acrylic container, we analyze different parameters such as the friction, density, amplitude and frequency of the oscillation, etc..

PROGRESS

We worked experimentally in a granular rotor in two regimes, firstly in the ‘independent kick regime’ and secondly in the ‘intermediate regime’ between the independent kick and Brownian limits. We submitted an article to Journal of Statistical Mechanics: Theory and Experiment (JSTAT). Moreover, we build a new setup for the Leidenfrost experiment. We are studying the presence of a low-frequency oscillation in a granular bed. The experimental results agreement with the numerical results obtained for N. Rivas et al (New Journal of Physics, 2013). We are writing an article related with this work. At present, we are studying impact and settling in a cornstarch suspension, for which we investigate the influence of the suspending fluid on the suspension behavior. This work was already presented as a poster in two conferences.

DISSERTATIONS

1. Huisman, Sander Gerard (2014) Taylor-Couette turbulence. thesis.

SCIENTIFIC PUBLICATIONS

1. Huisman, S. G., van der Veen, R. C. A., Sun, C., & Lohse, D. (2014). Multiple states in highly turbulent Taylor–Couette flow. *Nature Communications*, 5(May), 1–5. doi:10.1038/ncomms4820.
2. Ostilla-Mónico, R., Huisman, S. G., Jannink, T. J. G., van Gils, D. P. M., Verzicco, R., Grossmann, S., ... Lohse, D. (2014). Optimal Taylor–Couette flow: radius ratio dependence. *Journal of Fluid Mechanics*, 747, 1–29. doi:10.1017/jfm.2014.134.

PROJECTLEADERS

D van der Meer

RESEARCHTHEME

Complex dynamics of fluids

PARTICIPANTS

L Oyarte Gálvez, D van der Meer

COOPERATIONS

-

FUNDED

Becas Chile - CONICYT

University -

FOM -

STW -

NWO Other -

Industry -

TNO -

GTI -

EU -

Scholarships 100 %

START OF THE PROJECT

2013

INFORMATION

L Oyarte Galvez

053 489 5249

l.a.oyartegalvez@utwente.nl

<http://stilton.tnw.utwente.nl/people/devaraj/index.html>

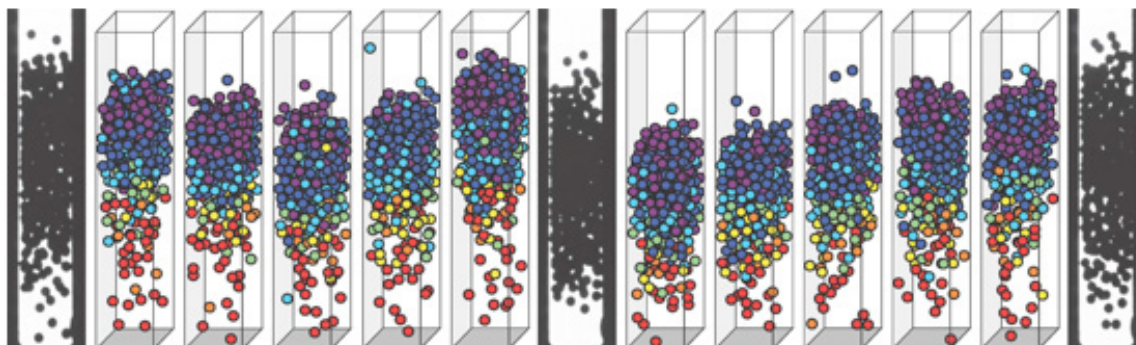

MENISCUS AND BUBBLE DYNAMICS AND DROPLET IMPACT AND EVAPORATION IN DROP ON DEMAND INKJET PRINTING

PROJECT LEADERS

D Lohse, M Versluis

RESEARCH THEME

Complex dynamics of fluids

PARTICIPANTS

H Reinten (Océ), H Wijshoff (Océ),
M van den Berg (Océ), M-J van der
Meulen, E-J Staat, A Fraters

COOPERATIONS

Océ Technologies B.V. Venlo, NL

FUNDED

FOM IPP, NanoNextNL, HTSM 2012

Océ Technologies

University -

FOM 16,66 %

STW 36,66 %

NWO Other -

Industry 46,66 %

TNO -

GTI -

EU -

Scholarships -

START OF THE PROJECT

2011 (Van der Meulen)

2012 (Staat)

2014 (Fraters)

INFORMATION

M Versluis

a.m.versluis@utwente.nl

pof.tnw.utwente.nl

PROJECT AIM

The project encompasses an experimental and numerical study of multiple aspects of the inkjet printing process. The aim is to obtain insight in the movement of the liquid meniscus in the nozzle, asymmetric droplet formation, liquid meniscus instabilities leading to air bubble entrapment, bubble dynamics in the printhead, and inkjet droplet impact and evaporation on various media.

PROGRESS

Mark-Jan van der Meulen successfully finished his PhD.

A Boundary Integral code has been adapted and extended to simulate the meniscus motion in a printhead nozzle. An infrared imaging setup has been developed to study bubble dynamics in silicon MEMS chip of a printhead. An experimental setup is being developed to study the bubble entrapment process in a single glass printhead nozzle. An ultrafast imaging technique to measure the surface tension and viscosity of inkjet printed droplets in flight was developed. This technique was used to study the influence of surfactants on the surface tension of droplets just after droplet formation.

DISSERTATIONS

1. Mark-Jan van der Meulen, Meniscus motion and drop formation in inkjet printing, 19-02-2015.

SCIENTIFIC PUBLICATIONS

-

The shape mode oscillation of an inkjet printed droplet, from which the surface tension and viscosity of the droplet can be determined.



TOWARDS ULTIMATE TURBULENCE

PROJECT AIM

We focus on turbulence in closed systems, namely on Rayleigh-Bénard turbulence and Taylor-Couette turbulence. In these paradigmatic systems, the interplay between boundary layers and bulk is of particular importance. We want to understand the transition towards the so-called ultimate turbulent state, which for extremely strong driving had recently been found in both of these systems and which had been interpreted as an indication of the breakdown of laminar-type boundary layers.

PROGRESS

A pencil distributed parallelization technique has been used in our in house code called AFiD. A multiple-resolution strategy for direct numerical simulation of scalar turbulence has been developed. In Rayleigh-Bénard convection, we found the transition to the ultimate regime, in which the boundary layers are considered to be fully turbulent, can therefore be understood as a gradual increase in the fraction of the plume-emitting (“turbulent”) regions of the boundary layer. In Taylor-Couette turbulence, we found that the axial extent of the computational box directly reflects on the Taylor rolls and plays a crucial role on the correlations and spectra. For Taylor-Couette turbulence with roughness, we found that if the roughness is align with the flow, the scaling between Nusselt and Taylor number first goes larger than the ultimate scaling 0.38, then saturates back to it.

DISSERTATIONS

1. Structures, boundary layers and plumes in turbulent Rayleigh-Bénard convection
Erwin van der Poel, Jul 3, 2015. Highly turbulent Taylor-Couette flow: Direct numerical simulations. Rodolfo Ostilla Mónico, Feb 20, 2015.

SCIENTIFIC PUBLICATIONS

1. Logarithmic Mean Temperature Profiles and Their Connection to Plume Emissions in Turbulent Rayleigh-Bénard Convection. E.P. van der Poel, R. Ostilla Mónico, R. Verzicco, S. Grossmann, and D. Lohse. *Phys. Rev. Lett.* 115, 154501 (2015).
2. Plume emission statistics in turbulent Rayleigh- Bénard convection. E.P. van der Poel, R. Verzicco, S. Grossmann, and D. Lohse. *J. Fluid Mech.* 772, 5–15 (2015).
3. Salinity transfer in bounded double diffusive convection. Y. Yang, E.P. van der Poel, R. Ostilla Mónico, C. Sun, R. Verzicco, S. Grossmann, and D. Lohse *J. Fluid Mech.* 768, 476–491 (2015).
4. A multiple-resolution strategy for Direct Numerical Simulation of scalar turbulence. R. Ostilla Mónico, Y. Yang, E.P. van der Poel, D. Lohse, and R. Verzicco. *J. Comput. Phys.* 301, 308 – 321 (2015).
5. A pencil distributed finite difference code for strongly turbulent wall-bounded flows. E.P. van der Poel, R. Ostilla Mónico, J. Donners, and R. Verzicco. *Computers & Fluids* 116, 10 – 16 (2015).
6. Effects of the computational domain size on direct numerical simulations of Taylor-Couette. turbulence with stationary outer cylinder. R. Ostilla Mónico, R. Verzicco, and D. Lohse. *Phys. Fluids* 27, 025110 (2015).
7. Inertial waves and mean velocity profiles in a rotating pipe and a circular annulus with axial flow. Y. Yang, R. Ostilla Mónico, J. Wu, and P. Orlandi. *Phys. Rev. E* 91, 013015 (2015).

PROJECT LEADERS

D Lohse

RESEARCH THEME

Complex dynamics of fluids

PARTICIPANTS

E van der Poel, R Ostilla-Monico,
X Zhu

COOPERATIONS

Roberto Verzicco

FUNDED

FOM
University -
FOM 100 %
STW -
NWO Other -
Industry -
TNO -
GTI -
EU -
Scholarships -

START OF THE PROJECT

2014

INFORMATION

X Zhu
0615886769
Xiaojue.zhu@utwente.nl
<http://pof.tnw.utwente.nl/>

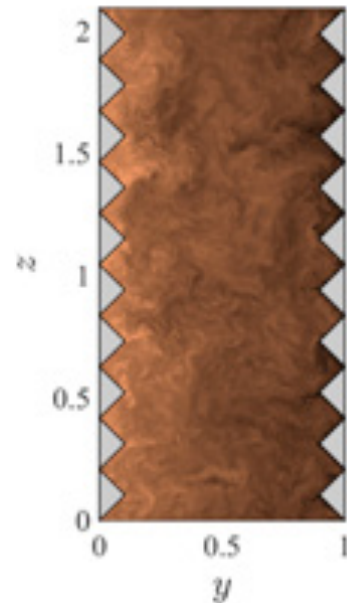

UNDERSTANDING THE SPATIO-TEMPORAL STRUCTURE OF HIGHLY INTERMITTENT TURBULENT FLOW IN WIND FARMS: HOW TO DEAL WITH LARGE FLUCTUATIONS?

PROJECT LEADERS

RJAM Stevens

RESEARCH THEME

Complex dynamics of fluids

PARTICIPANTS

RJAM Stevens, C Meneveau (Johns Hopkins University, USA),
DF Gayme (Johns Hopkins, USA),
M. Wilczek (Max Planck Gottingen, Germany), Tony Martinez (Johns Hopkins, USA)

COOPERATIONS

RJAM Stevens, C Meneveau (Johns Hopkins University, USA),
DF Gayme (Johns Hopkins, USA),
M. Wilczek (Max Planck Gottingen, Germany), Tony Martinez (Johns Hopkins, USA)

FUNDED

FOM	
University	-
FOM	100 %
STW	-
NWO Other	-
Industry	-
TNO	-
GTI	-
EU	-
Scholarships	-

START OF THE PROJECT

2012

INFORMATION

R Stevens
053 489 5359
r.j.a.m.stevens@utwente.nl

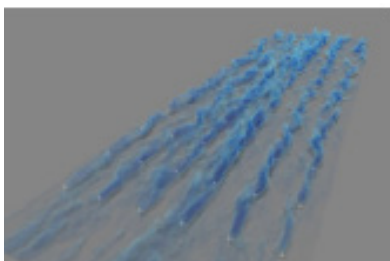

Visualization of the low speed wind regions indicated in blue in a very large wind-farm which shows the creation of turbulent wakes behind the turbines (visualization by David Bock, NCSA Visualization, XSEDE)

PROJECT AIM

In this project we use large eddy simulations to model the interaction between wind farms with many turbine rows in the downstream direction and the atmospheric boundary layer. We focus on the effect of the layout of the wind farm on its total power output and power fluctuations. We want to understand the influence of the properties of the very large-scale motions in the atmospheric boundary layer and the role of the turbulent fluctuations on the wind farm performance. Subsequently we want to translate this understanding to simpler models that can be used to predict properties of extended wind farms.

PROGRESS

We have developed the Coupled Wake Boundary Layer Model (CWBL) model that describes the power output of wind-turbines in a wind-farm as function of the main design parameters. The model combines an industry standard wake model approach with a simple 'momentum balance' based theory ('top-down' model). The wake model part captures the effect of turbine positioning, while the interaction between the wind-turbine wakes and the atmospheric boundary layer is represented in the 'top-down' part of the model. Based on comparisons with large eddy simulations (LES) results of wind-farms, see figure 1, we find that the CWBL model gives improved predictions for the power output of very large wind-farms compared to the predictions of stand-alone wake and 'top-down' models and using the CWBL model we studied the influence of wind-turbine spacing and incoming turbulence intensity on wind-farm performance. In addition, we used LES of atmospheric turbulent boundary layers to further develop a wavenumber-frequency model that is aimed at describing the velocity correlations in turbulent boundary layer flows.

DISSERTATIONS

-

SCIENTIFIC PUBLICATIONS

1. R.J.A.M. Stevens, D.F. Gayme, C. Meneveau, Coupled wake boundary layer model of wind farms, *J. of Renewable and Sustainable Energy* 7, 023115 (2015).
2. R.J.A.M. Stevens, Dependence of optimal wind-turbine spacing on wind-farm length, *Wind Energy*, DOI: 10.1002/we.1857 (2015).
3. R.J.A.M. Stevens, D.F. Gayme, C. Meneveau, Using the coupled wake boundary layer model to evaluate the effect of turbulence intensity on wind-farm performance, *J. Phys.: Conf. Ser.* 625, 012004 (2015). *J. Phys.: Conf. Ser.* 625, 012004 (2015).
4. M. Wilczek, R.J.A.M. Stevens, C. Meneveau, Height-dependence of spatio-temporal spectra of wall-bounded turbulence - LES results and model predictions, *J. Turbulence* 16, 937-949 (2015).
5. M. Wilczek, R.J.A.M. Stevens, C. Meneveau, Spatio-temporal spectra in the logarithmic layer of wall turbulence: large-eddy simulations and simple models, *J. Fluid Mech.*, 769, R1(2015).

IMPACT OF RAIN DROPS ON SAND

PROJECT AIM

The impact of a liquid droplet on a layer of grains is amongst the most common events in nature. Nevertheless, surprisingly little is known about the physics that governs it. First, we want to know what causes sand and water to mix during impact? Second, when there is no mixing, what controls the amount of momentum that is transferred from the liquid to the sand? Third, how can we understand the different crater shapes that are generated? With experimental work we want to resolve these questions.

PROGRESS

In 2015, we investigated the effect of wettability of the grains, its size and material density and the type of liquid. We observed that the maximum droplet spreading diameter decreases when the liquid inflow into the bed is increased. The mixing can be described as an increase of the boundary layer at the base of the drop, i.e., an effective increase of the viscosity. For the crater evolution, we found that avalanches play an important role, therefore we conclude that the transient crater shape at the moment the crater reaches maximum depth and its final shape needs to be distinguished in general. Furthermore, we obtain that the dependence of the final crater diameter on packing fraction is more pronounced for transient crater diameter.

DISSERTATIONS

-

SCIENTIFIC PUBLICATIONS

1. Exploring droplet impact near a millimetre-sized hole: comparing a closed pit with an open-ended pore, *Journal of Fluid Mechanics*, 2015, 772, pp 427-444, Rianne de Jong, Oscar R. Enríquez and Devaraj van der Meer.
2. Raindrop impact on sand: a dynamic explanation of crater morphologies, *Soft Matter*, 2015 11, pp. 6562 -6568, Song-Chuan Zhao, Rianne de Jong, and Devaraj van der Meer.

A sketch of the evolution of the crater shape at the moment the crater reaches its maximum depth and at its final shape.

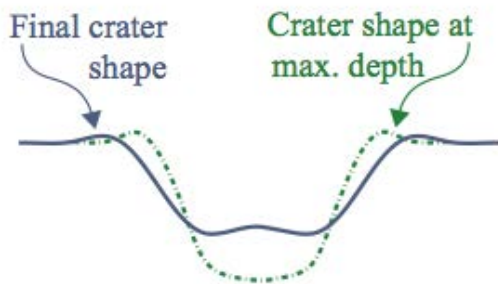

Maximum spreading of water droplet, D_d , is suppressed by increasing grain size d_g . Here, We_{\dagger} is the effective Weber number modified by the substrate deformation, and D_d is normalized by the initial droplet size, D_0 .

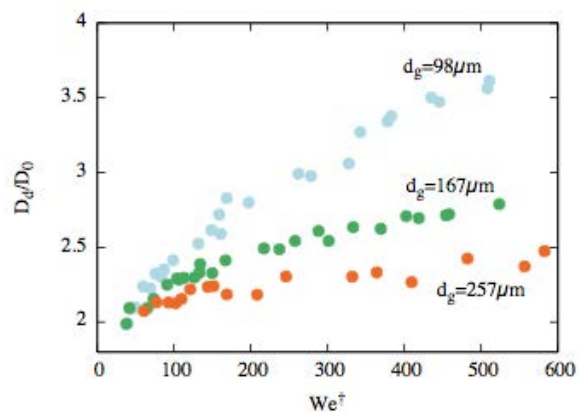

PROJECT LEADERS

D van der Meer

RESEARCH THEME

Complex dynamics of fluids

PARTICIPANTS

R de Jong, S Zhao

COOPERATIONS

-

FUNDED

NWO

University -

FOM -

STW -

NWO Other 100 %

Industry -

TNO -

GTI -

EU -

Scholarships -

START OF THE PROJECT

2012

INFORMATION

D van der Meer

053 489 2387

d.vandermeer@utwente.nl

PHYSICS OF BOILING

PROJECT LEADERS

D Lohse

RESEARCH THEME

Complex dynamics of fluids

PARTICIPANTS

S Wildeman

COOPERATIONS

-

FUNDED

ERC Advanced Grant

University -

FOM -

STW -

NWO Other -

Industry -

TNO -

GTI -

EU 100 %

Scholarships -

START OF THE PROJECT

2011

INFORMATION

S Wildeman

053 489 5289

s.wildeman@utwente.nl

PROJECT AIM

Study the phase-transition dynamics of liquids under metastable conditions, such as achieved by superheating or super cooling the liquid.

PROGRESS

The ability of liquids (and solids) to withstand large tensions leads to a rich variety of phenomena. Once this tension is released the liquid undergoes a rapid partial phase transition to a gas, a solid or a void. Because of the energy stored in the liquid (or solid) when the tension is build up, this phase transition is always sudden and 'explosive' as compared to the same transition taking place under milder conditions in which the tension is already released in an early stage. This explosive behavior gives the surrounding medium not much time to respond, leading to interesting and surprising interactions, especially if this medium is under tension as well. Three such cases were visualized and studied in-depth.

DISSERTATIONS

1. PhD Thesis, Liquids under tension, Sander Wildeman, Sept. 2015.

SCIENTIFIC PUBLICATIONS

1. Dynamics of high-speed micro-drop impact: numerical simulations and experiments at frame-to-frame times below 100 ns. C.W. Visser, P.E. Frommhold, S. Wildeman, R. Mettin, D. Lohse, and C. Sun. *Soft Matter* 11, 1708–1722 (2015).

Spontaneous explosive boiling of a small droplet of pentane superheated by 110 degrees K in a bath of hot oil. The whole sequence takes about two milliseconds."

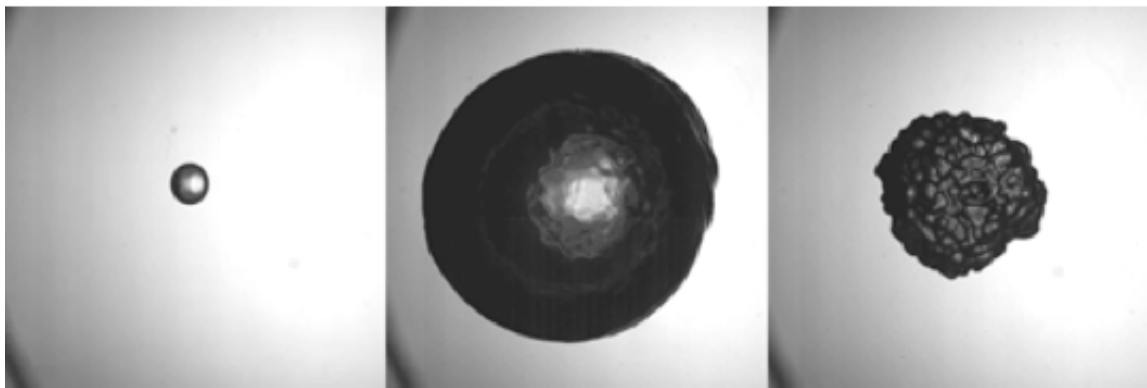

FUNDAMENTAL FLUID DYNAMICS CHALLENGES OF EXTREME ULTRAVIOLET LITHOGRAPHY

PROJECT AIM

A method to generate Extreme Ultraviolet (EUV) light is to ionize liquid tin drops by a laser pulse. The resulting hot plasma emits EUV radiation. Several of the challenges to make this method operational have their origin in contemporary fluid physics. Here, we focus on two of these fluid dynamics challenges. First, we study the deformation and fragmentation of liquid drops upon impact of a laser pulse. Second, we want to define the criteria for the splashing and bouncing of liquid drops on soft (visco-)elastic substrates and the role of heat transfer and liquid solidification during impact.

PROGRESS

We studied the impact of a laser pulse on a liquid drop combining detailed experiments with theoretical modeling. We identified the propulsion mechanism for water and metal drops, and determined how the drop deformation depends on the laser-pulse energy, beam profile and focus. A theoretical model to study compressible effect inside the droplet during violent impact was developed and found to be in good agreement with Lattice-Boltzmann simulations. We experimentally investigated the oblique impact of drops on a liquid pool. We identified the different impact regimes: splashing, jetting and secondary drop ejection as a function of Weber number and impact angle. Furthermore, we studied the spreading of hexadecane drops on a cold copper substrate and identified the condition for contact line arrest. We designed a set-up for the study of liquid tin drops impacting on cold substrates, for a range of drop sizes and impact velocities.

DISSERTATIONS

1. S. A. Reijers, Lattice-Boltzmann simulation of laser-impact on a drop, MSc thesis Eindhoven University of Technology 2015.

SCIENTIFIC PUBLICATIONS

1. A.L. Klein, W. Bouwhuis, C.W. Visser, H. Lhuissier, C. Sun, J.H. Snoeijer, E. Villermaux, D. Lohse and H. Gelderblom. Laser impact on a drop, Winning entry Gallery of Fluid Motion, Physics of Fluids 27, 091106 (2015).
2. A.L. Klein, W. Bouwhuis, C.W. Visser, H. Lhuissier, C. Sun, J.H. Snoeijer, E. Villermaux, D. Lohse and H. Gelderblom. Drop shaping by laser-pulse impact, Phys. Rev. Applied 3, 044018 (2015).

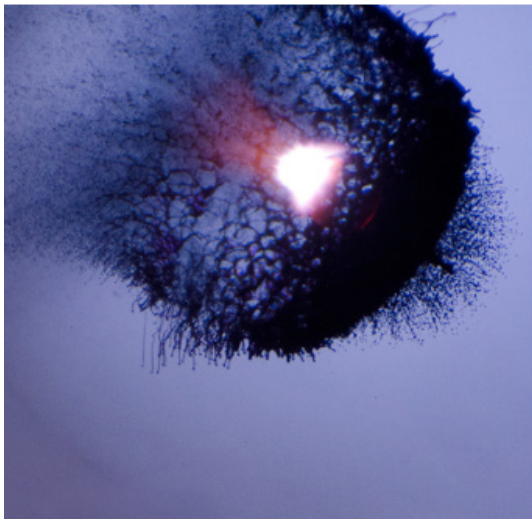

PROJECTLEADERS

H Gelderblom, JH Snoeijer, D Lohse

RESEARCHTHEME

Complex dynamics of fluids

PARTICIPANTS

MV Gielen, AL Klein, SA Reijers,
R de Ruijter, H Gelderblom,
JH Snoeijer, C Sun, D Lohse

COOPERATIONS

Villermaux, Université Aix-Marseille
Lhuissier, Université Aix-Marseille
Clanet, Ecole Polytechnique Paris
Versolato, Ubachs & Hoekstra,
ARCNL, Toschi, Eindhoven
University of Technology, ASML
Research

FUNDED

FOM, ASML	
University	-
FOM	50 %
STW	-
NWO Other	-
Industry	50 %
TNO	-
GTI	-
EU	-
Scholarships	-

START OF THE PROJECT

2013

INFORMATION

H Gelderblom
053 489 5955
h.gelderblom@utwente.nl
<http://stilton.tnw.utwente.nl/people/gelderblom/>

DRAG REDUCTION IN DISPERSED MULTIPHASE TAYLOR-COUPETTE TURBULENCE

PROJECT LEADERS

D Lohse, R Verzicco

RESEARCH THEME

Complex dynamics of fluids

PARTICIPANTS

Vamsi Spandan Arza.

COOPERATIONS

-

FUNDED

FOM-Shell CSER program

University -

FOM 100 %

STW -

NWO Other -

Industry -

TNO -

GTI -

EU -

Scholarships -

START OF THE PROJECT

2013

INFORMATION

D Lohse

053 489 8076

d.lohse@utwente.nl

pof.tnw.utwente.nl

PROJECT AIM

The objective of the project is to understand the mechanism of drag reduction in the well-defined geometry of Taylor-Couette (TC) turbulence, through numerical simulations within a two-way coupled Euler-Lagrange scheme. The key idea is to allow for bubble and droplet deformation by attributing the internal properties “deformation” and “orientation” to the dispersed particles. The results of this project will allow to reduce drag by optimally choosing the control parameters.

PROGRESS

Through two-way coupled numerical simulations, it was found that low Froude number bubbles assist in enhancing drag reduction in a bubbly Taylor Couette flow. A manuscript based on these results has already been submitted to Journal of Fluid Mechanics. The influence of outer-cylinder rotation on the drag reduction was studied for the first time in bubbly TC flows. Additional programming was done to allow for deformations in the dispersed phase. Simulations were performed for neutrally buoyant sub-Kolmogorov drops to study their deformation and orientation statistics in TC flow.

DISSERTATIONS

-

SCIENTIFIC PUBLICATIONS

1. Spandan, V., Ostilla-Monico, R., Verzicco, R., Lohse, D., “Direct Numerical Simulations of two-phase Taylor-Couette turbulence”, European Turbulence Conference (2015).

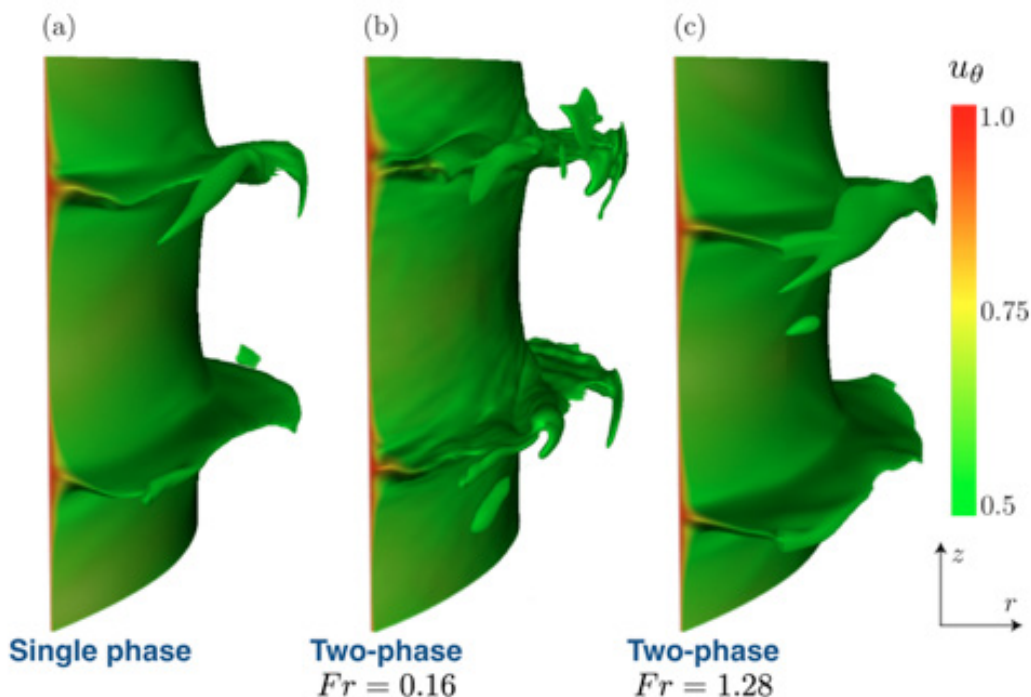

HEAT TRANSFER PROCESSES IN 3D PRINTING

PROJECT AIM

Understand the behavior of metal droplets impacting on substrates. Understand the influence of thermal conductance of a substrate on the mechanics of spreading, splashing and solidification. Study product level heat transfer processes and its influence on product properties.

PROGRESS

The project start at the end of august 2015. A literature study has been performed on modelling solidification with droplet spreading. An experimental setup has been designed which will come into use in 2016. The numerical code Gerris is used to look at droplet spreading and it has been extended to take heat transfer and solidification into account. A start on a thermal product model for the laser melting process has been made.

DISSERTATIONS

-

SCIENTIFIC PUBLICATIONS

-

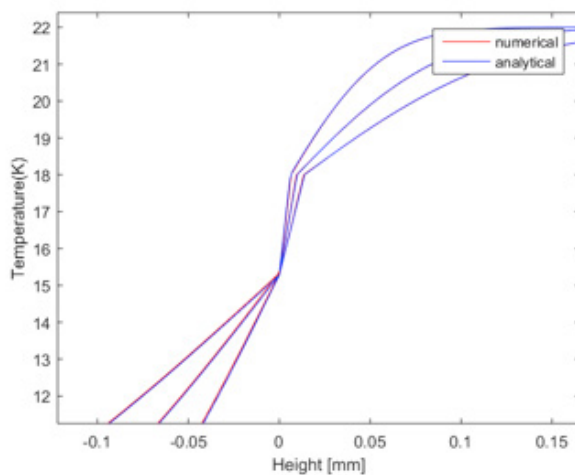
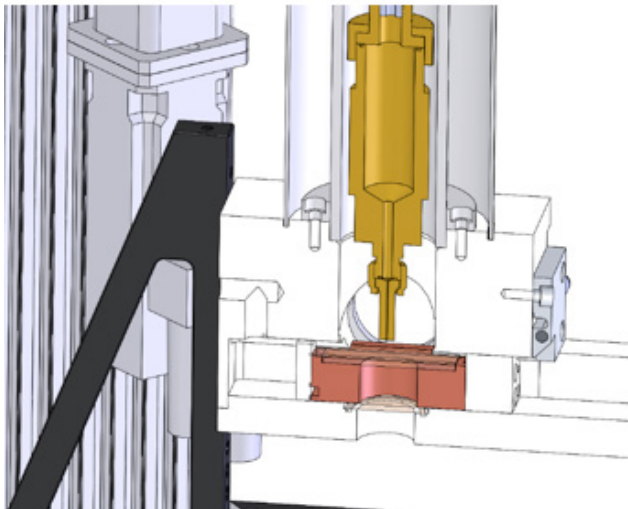

PROJECTLEADERS

D Lohse

RESEARCHTHEME

Complex dynamics of fluids

PARTICIPANTS

R Koldeweij

COOPERATIONS

from 2016 onwards HTSC
Eindhoven; laser model: NLR

FUNDED

TNO	-
University	-
FOM	-
STW	-
NWO Other	-
Industry	-
TNO	100 %
GTI	-
EU	-
Scholarships	-

START OF THE PROJECT

2015

INFORMATION

D Lohse
053 489 8076
d.lohse@utwente.nl
pof.tnw.utwente.nl

SURFACE NANOBUBBLES, BENEFIT AND HINDERANCE

PROJECT LEADERS

D Lohse, HJW Zandvliet

RESEARCH THEME

Complex structures of fluids

PARTICIPANTS

B Poelsema, P Bampoulis

COOPERATIONS

-

FUNDED

University	-
FOM	-
STW	-
NWO Other	100 %
Industry	-
TNO	-
GTI	-
EU	-
Scholarships	-

START OF THE PROJECT

2013

INFORMATION

P Bampoulis
p.bampoulis@utwente.nl

PROJECT AIM

To study the behavior and properties of interfacial nano- and microbubbles, layers and droplets at solid liquid interfaces.

PROGRESS

The structure and behavior of the interfacial contact between water and solid surfaces are of the highest fundamental and practical interest in environmental sciences, many biological systems, in corrosion effects and (nano)fluidics. We study intercalated water between a hydrophobic graphene layer and a hydrophilic (and hydrophobic) substrate (s), for instance mica and MoS₂. We observed exciting physical phenomena, substantially different from bulk equivalents. A continuous multilayer crystal-like water film is observed by Scanning probe Microscopies. by changing the nature of confinement hydrophobic/hydrophobic or hydrophilic/hydrophilic as well as the structural properties of the surfaces, the structure and behavior of water changes substantially. Droplet-like structures as well as unconventional layered water films with rich phases are observed.

DISSERTATIONS

-

SCIENTIFIC PUBLICATIONS

1. Berkelaar, R.P., Bampoulis, P., Dietrich, E., Jansen, H.P., Zhang, Xuehua, Kooij, E.S., Lohse, D. & Zandvliet, H.J.W. (2015). Water induced blister formation in a thin film polymer. *Langmuir*, 31, 1017-1025.
2. P Bampoulis, MH Siekman, ES Kooij, D Lohse, HJW Zandvliet, B Poelsema. (2015). Latent heat induced rotation limited aggregation in 2D ice nanocrystals. *The Journal of chemical physics* 143 (3), 034702.
3. L Zhang, P Bampoulis, A van Houselt, HJW Zandvliet. (2015). Two-dimensional Dirac signature of germanene. *Applied Physics Letters* 107 (11), 111605.
4. A Acun, L Zhang, P Bampoulis, M Farmanbar, A van Houselt, AN Rudenko, M Lingensfelder, G Brocks, B Poelsema, MI Katsnelson, HJW Zandvliet. (2015). Germanene: the germanium analogue of graphene. *Journal of Physics: Condensed Matter* 27 (44), 443002.

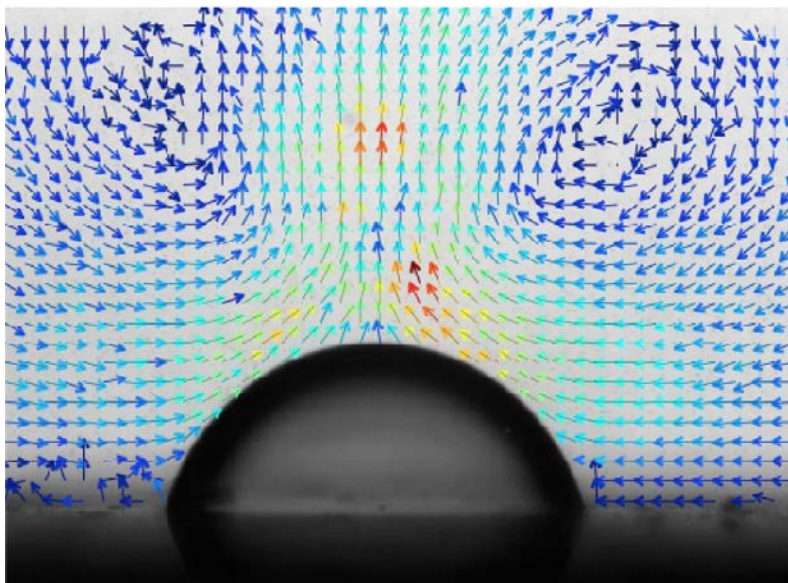

DRAG REDUCTION IN GRANULAR MEDIA : THE INTERPLAY BETWEEN AIR PRESSURE AND COMPACTY

PROJECT AIM

Earlier works has shown that the pressure of the air between the grains of a granular media has a big effect on the value of the drag force that encounter any moving object. This affects a lot for example the dynamics of impacting object into granular. The aim of this project is to understand quantitatively through systematic experiments what is the role of the compaction of the granular media and the pressure of the interstitial air on the drag force.

PROGRESS

In early 2015, I modified and improved a former set up which was used to study the effect of interstitial air pressure on the drag exerted by a granular media on a penetration ball. The new set up allows to also study the effect of granular compaction. This set up is now fully operational and a large set experiments were performed exploring systematically the parameters space : compaction, penetrating velocity and air pressure. Preliminary analysis of the large data set show that the role of air is different ever the compaction is below or above the dilatant critical compaction which is estimated to 0.426 for our granular media (cf figure). We observe a reduction of drag with increasing air pressure for low packing fraction. For large packing fraction, an higher air pressure induces an increase of the drag force in the initial stage of the penetration experiment. Then, for larger penetration depth, we observe tendencies similar to the ones observed for loose packing.

DISSERTATIONS

-

SCIENTIFIC PUBLICATIONS

-

PROJECT LEADERS

D van der Meer

RESEARCH THEME

Complex dynamics of fluids

PARTICIPANTS

A Ponsj

COOPERATIONS

-

FUNDED

NWO

University -

FOM -

STW -

NWO Other 100 %

Industry -

TNO -

GTI -

EU -

Scholarships -

START OF THE PROJECT

2015

INFORMATION

D van der Meer

053 489 2387

d.vandermeer@utwente.nl

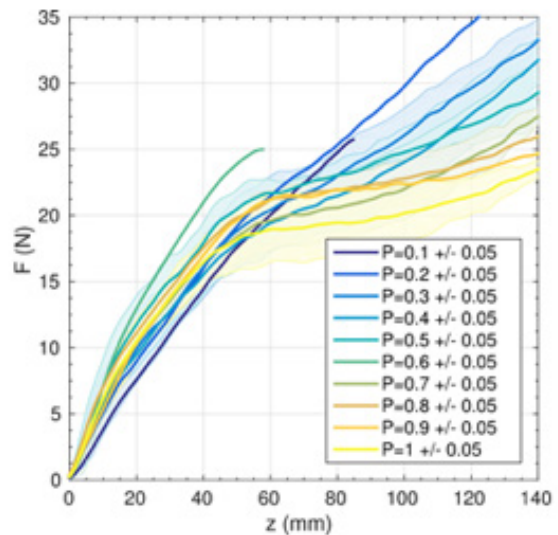
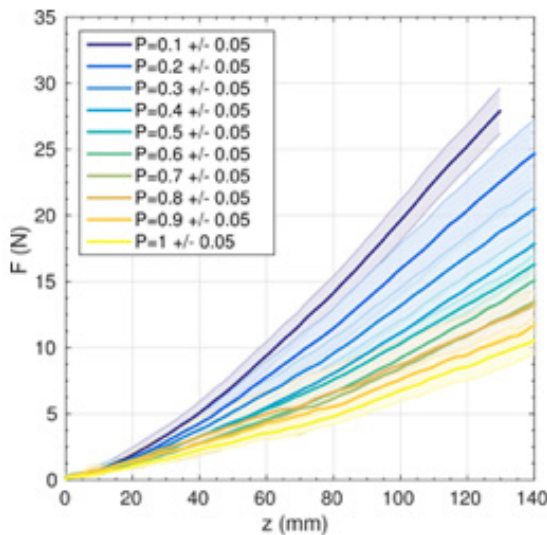

PROJECT LEADERS

D Lohse

RESEARCH THEME

Complex dynamics of fluids

PARTICIPANTS

Y Yang, R Verzicco, E van der Poel

COOPERATIONS

-

FUNDED

FOM

University -

FOM 100 %

STW -

NWO Other -

Industry -

TNO -

GTI -

EU -

Scholarships -

START OF THE PROJECT

2015

INFORMATION

D Lohse

053 489 8076

d.lohse@utwente.nl

pof.tnw.utwente.nl

PROJECT AIM

Double diffusive convection: Study double diffusive convection by combining large scale numerical simulations and theoretical model.

PROGRESS

Double diffusive convection:

1. Developed a mass-conserving interpolation method for the multiple resolution scheme of scalar turbulence;
2. Conducted systematic numerical simulations of double diffusive convection, and developed theoretical models to explain the key responses of the flow.

DISSERTATIONS

1. Structures, boundary layers and plumes in turbulent Rayleigh-Bénard convection, E.P. van der Poel, promotiedatum 3 juli 2015.

SCIENTIFIC PUBLICATIONS

1. Yang, Y., van der Poel, E.P., Ostilla-Monico, R., Sun, C., Verzicco, R., Grossmann, S. and Lohse, D., 2015. Salinity transfer in bounded double diffusive convection. *J. Fluid Mech.*, 768, 476-491.
2. Ostilla-Monico, R., Yang, Y., van der Poel, E.P., Lohse, D. and Verzicco, R., 2015. A multiple-resolution strategy for Direct Numerical Simulation of scalar turbulence. *J. Comp. Phys.*, 301, 308-321.
3. Yang, Y., Ostilla-Monico, R., Wu, J. and Orlandi, P., 2015. Inertial waves and mean velocity profiles in a rotating pipe and a circular annulus with axial flow. *Phys. Rev. E*, 91, 013015.
4. Chen, S., Xia, Z., Wang, J. and Yang, Y., 2015. Recent progress in compressible turbulence. *Acta Mech. Sin.*, 31, 275-291.
5. Logarithmic Mean Temperature Profiles and Their Connection to Plume Emissions in Turbulent Rayleigh-Bénard Convection. E.P. van der Poel, R. Ostilla Mónico, R. Verzicco, S. Grossmann, and D. Lohse. *Phys. Rev. Lett.* 115, 154501.
6. Plume emission statistics in turbulent Rayleigh Bénard convection. E.P. van der Poel, R. Verzicco, S. Grossmann, and D. Lohse. *J. Fluid Mech.* 772, 5-15 (2015)
7. A pencil distributed finite difference code for strongly turbulent wall-bounded flows. E.P. van der Poel, R. Ostilla Mónico, J. Donners, and R. Verzicco *Computers & Fluids* 116, 10 – 16 (2015).
8. Yang, Y., van der Poel, E.P., Ostilla-Monico, R., Sun, C., Verzicco, R., Grossmann, S. and Lohse, D., Double diffusive convection bounded by two parallel plates. International Conference on Rayleigh-Bénard Turbulence 2015. June, 2015, Gottingen, Germany.
9. Yang, Y., van der Poel, E.P., Ostilla-Monico, R., Sun, C., Verzicco, R., Grossmann, S. and Lohse, D., Double diffusive convection between two parallel plates with different boundary conditions. 15th European Turbulence Conference. August 2015, Delft, the Netherlands.
10. Yang, Y., Verzicco, R. and Lohse, D., From convection rolls to finger convection in double-diffusive turbulence. APS 68th Annual DFD meeting. Nov. 2015, Boston, USA.

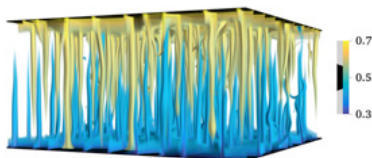

Three-dimensional volume rendering of the salt fingers in double diffusive convection

1) LIGHT PARTICLES IN TURBULENCE AND 2) FUNDAMENTALS OF HEAT TRANSPORT IN BUBBLY FLOWS

PROJECT AIM

1a) To study the translational dynamics of light particles in homogeneous isotropic turbulence.

1b) To study the role of gravity on small buoyant particle acceleration statistics.

1c) To develop a robust method for tracking absolute orientation and particles in turbulence.

2a) To look at the influence of bubble injection on the global and local heat flux in turbulent bubbly flow.

2b) To study the influence of the bubble diameter and gas volume fraction.

2c) To study the influence of the bubble clustering on the local and global heat flux.

PROGRESS

1a) We have mapped out the translation dynamics of rigid light particles from small to large Galileo numbers, by systematically varying the density and size ratios (publication listed below).

2b) The role of gravity has been studied and we developed a theoretical model to predict this for light and heavy particles in homogeneous turbulence. A manuscript is under preparation.

3c) Rotation tracking technique has been developed in the PoF group and a manuscript is under review.

2a) We have developed the measurement technique for local heat flux measurements in bubbly flow.

2b) We have designed the set up (Baby Water Tunnel) to study the heat transfer in turbulent bubbly flow.

2c) We have designed and built the experimental setup (Bubble Column) to study the heat transfer in a bubbly flow.

DISSERTATIONS

SCIENTIFIC PUBLICATIONS

1. Wake-driven dynamics of finite-sized buoyant spheres in turbulence” V. Mathai, V. N. Prakash, J. Brons, C. Sun, and D. Lohse. Phys. Rev. Lett. 115, 124501 (2015).
2. Energy spectra in bubbly turbulence”, V. N. Prakash, J. M. Mercado, L. van Wijngaarden, F. E. M. Ramos, Y. Tagawa, D. Lohse and C. Sun, (2015) [arXiv] (accepted by JFM).

PROJECTLEADERS

D Lohse, C Sun

RESEARCHTHEME

Complex dynamics of fluids

PARTICIPANTS

V Mathai, B Gvozdic, E Alm eras

COOPERATIONS

EuHIT, FOM, STW, COST MP1305

FUNDED

STW, EuHIT, FOM

University -

FOM 66 %

STW 34 %

NWO Other

Industry -

TNO -

GTI -

EU -

Scholarships -

START OF THE PROJECT

2015

INFORMATION

C Sun

c.sun@utwente.nl

<http://stilton.tnw.utwente.nl/people/sunc/>

sunc/

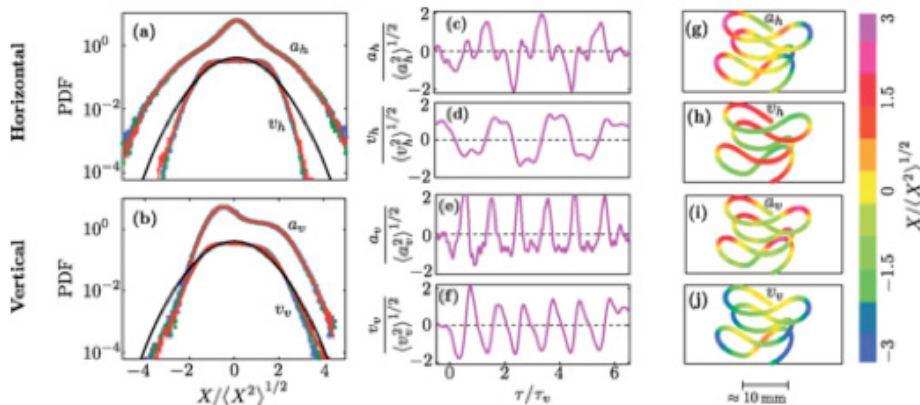

SOFT WETTING

PROJECT LEADERS

JH Snoeijer

RESEARCH THEME

Complex dynamics of fluids

PARTICIPANTS

S Karpitschka, M van Gorcum,
A Pandey, L Mensink

COOPERATIONS

Bruno Andreotti, ESPCI Paris

FUNDED

ERC	
University	-
FOM	-
STW	-
NWO Other	
Industry	-
TNO	-
GTI	-
EU	100 %
Scholarships	-

START OF THE PROJECT

2014

INFORMATION

J Snoeijer
053 489 3085
j.h.snoeijer@utwente.nl
<http://stilton.tnw.utwente.nl/people/snoeijer/>

PROJECT AIM

Wetting phenomena are abundant in nature and technology. While one usually considers the wetted solid to be perfectly rigid, this is not the case for the wetting of extremely soft materials such as gels or elastomers: the surface exhibits strong elastic deformations induced by capillarity, dramatically altering the wetting behavior. The aim of this project is to reveal the fundamental laws that govern "Soft Wetting" and to develop predictive tools to describe dynamics of wetting and lubrication of soft solids.

PROGRESS

We carried out systematic experiments on drops spreading over very soft silicone gels. We found remarkable dynamics, showing stick-slip motion of the contact line followed by extremely slow relaxations. It turns out that the wetting dynamics is entirely governed by the viscoelastic rheology of the solid: we derived a fully quantitative theory for the dynamic contact angle based on the substrate viscoelasticity. In addition, it was found that droplets exhibit a mutual interaction through elastic deformation, which can be seen as the inverse of the "Cheerios effect". Finally, we were able to quantify theoretically the influence of viscoelasticity on lubrication properties of highly deformable media.

DISSERTATIONS

-

SCIENTIFIC PUBLICATIONS

1. S. Karpitschka, S. Das, M. van Gorcum, H. Perrin, B. Andreotti and J.H. Snoeijer, Droplets move over viscoelastic substrates by surfing a ridge Nature Communications 6, 7891 (2015).

NUCLEATION AND DIFFUSIVE DYNAMICS OF OIL DROPLETS AND GAS BUBBLES IN LIQUIDS

PROJECT AIM

We want to experimentally analyze and understand the properties and dynamics of surface nanobubbles and surface nanodroplets, using ultrafast imaging. In particular, we want to understand collective effects of surface nanobubbles and surface nanodroplets, in particular the Ostwald ripening, which is related to their size distribution, surface coverage, and spatial arrangements.

PROGRESS

Nanodroplets on a solid surface (i.e., surface nanodroplets) have practical implications for high throughput chemical and biological analysis, lubrications, laboratory-on-chip devices, and near-field imaging techniques. Oil nanodroplets can be produced on a solid-liquid interface in a simple step of solvent exchange in which a good solvent of oil is displaced by a poor solvent. In this work, we experimentally and theoretically investigate the formation of nanodroplets by the solvent exchange process under well-controlled flow conditions. We find significant effects from the flow rate and the flow geometry on the droplet size. We develop a theoretical framework to account for these effects. The main idea is that the droplet nuclei are exposed to an oil oversaturation pulse during the exchange process. The analysis shows that the volume of the nanodroplets increases with the Peclet number Pe of the flow as $\propto Pe^{3/4}$, which is in good agreement with our experimental results. In addition, at fixed flow rate and thus fixed Peclet number, larger and less homogeneously distributed droplets formed at less-narrow channels, due to convection effects originating from the density difference between the two solutions of the solvent exchange. The understanding from this work provides valuable guidelines for producing surface nanodroplets with desired sizes by controlling the flow conditions.

DISSERTATIONS

-

SCIENTIFIC PUBLICATIONS

1. Formation of surface nanodroplets under controlled flow conditions. X. Zhang, Z. Lu, H. Tan, L. Bao, Y. He, C. Sun, and D. Lohse. *Proc. Natl. Acad. Sci. USA* 112, 9253–9257 (2015).
2. Gravitational Effect on the Formation of Surface Nanodroplets. H. Yu, Z. Lu, D. Lohse, and X. Zhang. *Langmuir* 31, 12628–12634 (2015).

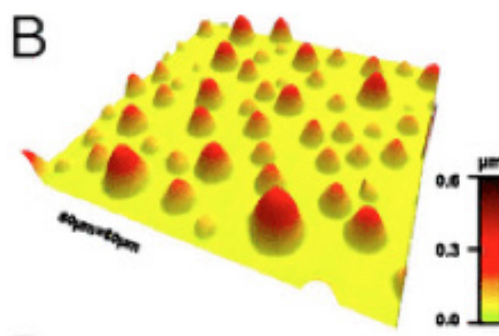
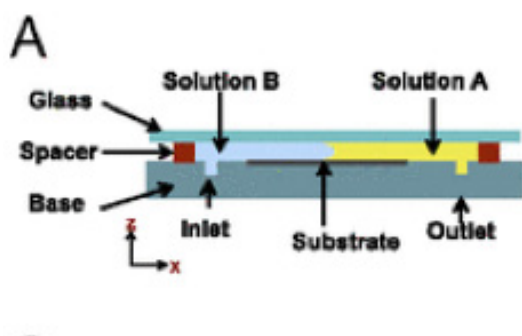

PROJECT LEADERS

D Lohse

RESEARCH THEME

Complex dynamics of fluids

PARTICIPANTS

Huanshu Tan, Pengyu Liu, Xuehua Zhang

COOPERATIONS

RMIT, Melbourne, Australia

FUNDED

CSC	
University	-
FOM	-
STW	-
NWO Other	-
Industry	-
TNO	-
GTI	-
EU	-
Scholarships	100 %

START OF THE PROJECT

2014

INFORMATION

D Lohse
053 489 8076
d.lohse@utwente.nl
pof.tnw.utwente.nl

SURFACE GAS BUBBLES IN THE CONTEXT OF CATALYTIC REACTIONS

PROJECT LEADERS

D Lohse

RESEARCH THEME

Complex dynamics of fluids

PARTICIPANTS

Alvaro Moreno Soto, Devaraj van der Meer, Vitaly Sveotovoy, Ivan Devic and Detlef Lohse

COOPERATIONS

University Carlos III (Madrid),
University of Utrecht

FUNDED

NWO Zwaartekracht, MCEC,
University of Twente

University	-
FOM	-
STW	-
NWO Other	100 %
Industry	-
TNO	-
GTI	-
EU	-
Scholarships	-

START OF THE PROJECT

2015

INFORMATION

A Moreno Soto
053 489 5974
a.morenosoto@utwente.nl
<http://www.mcec-researchcenter.nl/>

PROJECT AIM

We want to study new ways of transporting gas away from the catalyst surface by (i) controlling the bubble size, (ii) enhancing bubble nucleation and growth and (iii) controlling the fluid flow using bubble detachment and buoyancy. We will conduct experiments in a unique experimental setup that allows for complete and independent control of pressure and supersaturation level during bubble nucleation, formation, and detachment from a micropatterned surface. More specifically, we will study how isolated bubbles grow in confinement, how they detach, and how much fluid they are able to advect. Next we will turn to how multiple growing bubbles influence each other as a function of their distance. And finally we will address how bubbles nucleate and grow on a photoelectrolytic surface.

PROGRESS

Finished and revising first publication in collaboration with the University Carlos III (Madrid), finished experiments in bubble growth for long term effects and analyzing data for the second publication. Starting project in catalysis within the University of Twente but maintaining collaboration with the University of Utrecht.

DISSERTATIONS

-

SCIENTIFIC PUBLICATIONS

-

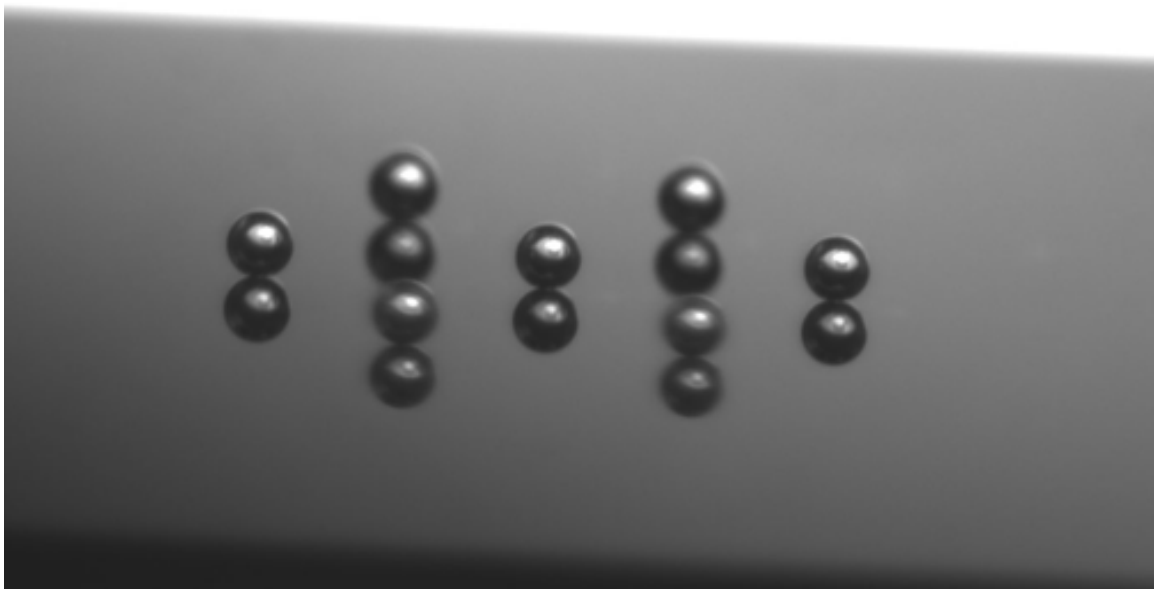





Prof.dr. F Mugele

MISSION

The goal of the PCF group is to understand and control the structure and the mechanical properties of liquids and interfaces on length scales ranging from molecular to submillimeter scales. The activities fall in three main categories: i) nanofluidics, ii) (electro)wetting & microfluidics, iii) soft matter mechanics. Our nanofluidics research focuses on understanding the range of validity of macroscopic continuum physics and in its breakdown upon approaching molecular scales, where physico-chemical aspects become increasingly important. In microfluidics, many properties of fluids, in particular drops, are controlled by interfacial effects. By patterning surfaces and in particular by making use the electrowetting effect we control the shape, the motion, and the generation of microdrops. These processes involve various challenging fundamental issues, such as contact angle hysteresis, the dynamics of contact lines, and hydrodynamic singularities. The soft matter mechanics activities focus on correlations between the internal structure of various types of complex fluids ranging from colloidal suspensions to living cells and their macroscopic viscous and elastic properties.

By improving the physical understanding of fundamental phenomena we contribute to the improvement of various technological processes involving fluid motion on small scales, including oil recovery, immersion lithography, and inkjet printing. This work is frequently carried out in collaboration with industrial partners including BP, Shell, ASML, Océ, Liquavista, sometimes within government sponsored consortia such as FOM-IPPs, sometimes in direct collaboration. A major project on enhanced oil recovery started in late 2009 and became fully operational in 2010. In this context, the group intensified its activities in the area of physical chemistry of liquid-liquid and solid-liquid interfaces. In late 2010, Prof. Mugele obtained a NWO-VICI grant to investigate the properties of superhydrophobic surfaces that are functionalized by electric fields. One major goal of the project is to explore various applications of such smart surfaces for microfluidics, ultrasound detection, and in particular optofluidics.

CELL-SPREAD

PROJECT AIM

To detect, per patient, the presence and affinity of therapeutic targets on a single circulating tumor cells (CTC). Digital microfluidics is used to create drops containing 1 CTC and guide the drop over a gold substrate patched with specific ligands targeting specific molecules. Using surface plasmon resonance imaging (SPRi) the binding processes of cell excreted proteins are quantified, effectively characterizing the cancer cell. This would allow for a quick diagnostic tool to administer the right type of medicine.

PROGRESS

Experimentally, a three-electrode geometry is used to actively sort water drops at 1200 drops per second. Experiments showed the microchip was capable of sorting conductive drops, but also non-conductive drops with a high relative permittivity (DEP). This work was published in *Biomicrofluidics*. The setup is now being improved by adding fluorescent detection and real-time sorting of droplets which contain a cell. Another chip was created for the trapping of a drop atop a hydrophilic patch. The hydropatch resembles a spot with printed biomolecules. This chip was capable of trapping a drop with electrodes, then holding the drop on the hydropatch and then releasing the droplet using a second set of electrodes. As a side project the transport, splitting and merging of droplets using a standard EWOD / digital microfluidics setup was shown atop inkjet printed electrodes. Furthermore, a review was written (*Micromachines*) on the possible techniques for passive and active controlling of droplets in oil-water microfluidics.

DISSERTATIONS

-

SCIENTIFIC PUBLICATIONS

1. Arjen M. Pit, Riëlle de Ruiter, et al. High-throughput sorting of drops in microfluidic chips using electric capacitance, *Biomicrofluidics* 9, 044116 (2015); <http://dx.doi.org/10.1063/1.4928452>.
2. Arjen M. Pit, Michèl H. G. Duits and Frieder Mugele. Droplet Manipulations in Two Phase Flow Microfluidics, *Micromachines* 2015, 6(11), 1768-1793; <http://dx.doi.org/10.3390/mi6111455>.



Link to youtube channel with several videos of droplets being trapped, released, guided, sorted at high speed, split in two equal volumes.

Also, a video where a droplet is trapped atop a hydrophilic patch is presented, and a video of EWOD on inkjet printed electrodes.

PROJECTLEADERS

LWMM Terstappen, F Mugele,
MHG Duits

RESEARCHTHEME

Complex dynamics of fluids

PARTICIPANTS

AM Pit, I Stojanović

COOPERATIONS

-

FUNDED

STW, Micronit, IBIS, Ssens, Sanquin,
Merus

University	-
FOM	-
STW	83 %
NWO Other	-
Industry	17 %
TNO	-
GTI	-
EU	-
Scholarships	-

START OF THE PROJECT

2011

INFORMATION

AM Pit
053 489 3093
a.m.pit@utwente.nl
<http://www.utwente.nl/tnw/pcf/>

FUNDAMENTAL ASPECTS OF FRICTION: A STUDY OF INTERACTION FORCES AT THE SOLID-LIQUID INTERFACES BY ATOMIC FORCE MICROSCOPY

PROJECT LEADERS

F Mugele

RESEARCH THEME

Complex dynamics of fluids

PARTICIPANTS

F Liu, F Mugele, HMT van den Ende

COOPERATIONS

-

FUNDED

FOM

University -

FOM 100 %

STW -

NWO Other -

Industry -

TNO -

GTI -

EU -

Scholarships -

START OF THE PROJECT

2011

INFORMATION

F Mugele

053 489 3094

f.mugele@utwente.nl

<http://www.utwente.nl/tnw/pcf/>

PROJECT AIM

To study interaction forces at solid-liquid interfaces, including electrostatic forces, hydration forces, and hydrodynamic dissipation.

To explore the force spectroscopy of Atomic Force Microscopy in liquid and establish reliable and efficient methods for force measurements.

PROGRESS

In our previous work, we showed that the thermal noise spectroscopy (TNS) is reliable for force measurements in liquid. However, it is time-consuming. Therefore, we used TNS as a benchmark to validate a faster (but often criticized) approach—amplitude modulation with piezo excitation (AM-AFM). We compared the results from AM-AFM to those from TNS in the measurements of DLVO forces, hydration forces, and dissipation. We found that AM-AFM with piezo excitation is also quantitatively reliable if the fluid excitation is taken into account. We found that the hydrodynamic dissipation is enhanced in overlapping electrical double layers and the enhancement is correlated with surface charge density. We attempted to model the enhancement with the conventional Poisson-Boltzmann theory and hydrodynamics in the continuum regime. Our model is able to qualitatively explain the enhancement. A quantitative understanding is not achieved yet, which may ask for insights into ionic transport at charged interfaces and hydration dissipation in the non-continuum regime.

DISSERTATIONS

-

SCIENTIFIC PUBLICATIONS

1. Amplitude modulation atomic force microscopy, is acoustic driving in liquid quantitatively reliable? Fei Liu, Cunlu Zhao, Frieder Mugele, and Dirk van den Ende. *Nanotechnology* 26, 385703 (2015)

MODELLING AND SIMULATION OF ELECTROWETTING AND MICROFLUIDICS SYSTEMS

PROJECT AIM

The aim of the project is to provide modelling and numerical simulations for the different microfluidics projects in the PCF group, tailored on the ongoing experimental research in the group. Main focus areas are electrowetting based devices, reversible wetting transitions and the effect of ions absorption on wettability. The tools developed at PCF are also applied to support the electrowetting research carried out at Liquavista. The main contribution in this sense is the development and maintenance of a multiphysics openFoam code to simulate and optimize electrowetting-based pixels.

PROGRESS

We carried out a numerical investigation on the ejection ("jump") of droplets through electrowetting. published in the February 2016 issue of Physics of Fluids. I investigated the effect of electrostatics interactions in thin films on wettability, using a linearized charge-regulation model (under revision on PRE). I collaborated with visiting Ph.D. student Nicolao Lima to simulate liquid lenses with tunable astigmatism (paper accepted in Optics Express). I collaborated to the optimization of pixel design at Liquavista.

DISSERTATIONS

-

SCIENTIFIC PUBLICATIONS

1. Numerical investigation of dynamic effects for sliding drops on wetting defects
A Cavalli, M Musterd, F Mugele. Physical Review E 91 (2), 023013.
2. On the shape of a droplet in a wedge: new insight from electrowetting
D Baratian, A Cavalli, D van den Ende, F Mugele. Soft matter 11 (39), 7717-7721.
3. Ion adsorption-induced wetting transition in oil-water-mineral systems
F Mugele, B Bera, A Cavalli, I Siretanu, A Maestro, M Duits, Martien Cohen-Stuart, Dirk van den Ende, Isabella Stocker, Ian Collins. Scientific reports 5 (2015).
4. Superamphiphobic Surfaces. Andrea Cavalli and Frieder Mugele. Academic Press, Droplet Wetting and Evaporation, Chapter 5 (2015).

PROJECT LEADERS

F Mugele

RESEARCH THEME

Mathematical and computational methods for fluid flow analysis

PARTICIPANTS

A Cavalli

COOPERATIONS

J Busch, Harvard

FUNDED

STW	
University	-
FOM	-
STW	50 %
NWO Other	-
Industry	50 %
TNO	-
GTI	-
EU	-
Scholarships	-

START OF THE PROJECT

2013

INFORMATION

F Mugele
053 489 3094
f.mugele@utwente.nl
www.utwente.nl/tnw/pcf/

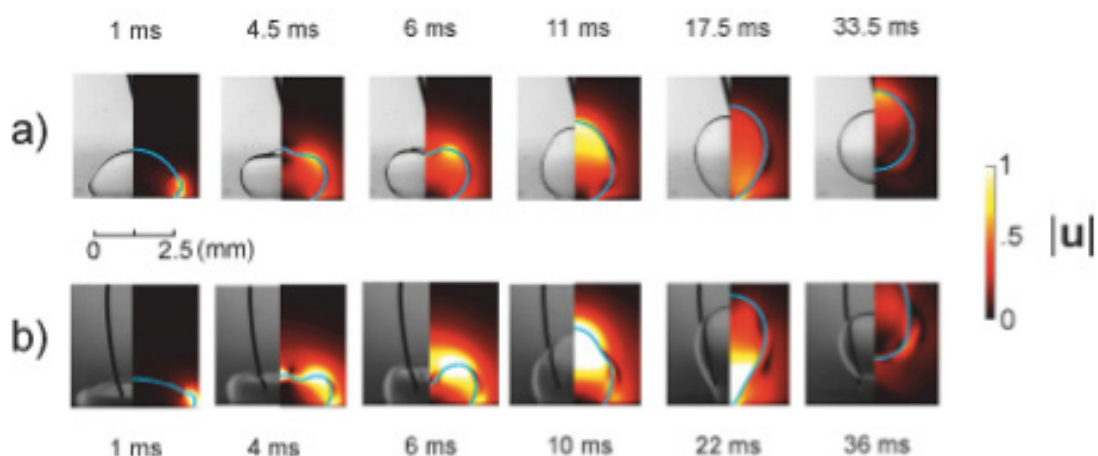

SURFACE CHARGE CHARACTERIZATION OF HETEROGENEOUS ROCK/CLAY MATERIALS

PROJECT LEADERS

F Mugele

RESEARCH THEME

Complex dynamics of fluids

PARTICIPANTS

N Kumar, I Siretanu, HTM van den Ende, F Mugele

COOPERATIONS

Max Planck Institute for Dynamics and Self-Organization, University of Copenhagen. BP

FUNDED

BP	
University	-
FOM	-
STW	-
NWO Other	-
Industry	100 %
TNO	-
GTI	-
EU	-
Scholarships	-

START OF THE PROJECT

2011

INFORMATION

N Kumar
053 489 2612
n.kumar-1@utwente.nl
<http://www.utwente.nl/tnw/pcf/>

PROJECT AIM

The aim of the project is to

- characterize surface charge of heterogeneous rock/clay materials with high resolution AFM technique
- Analysis of specific ion effect
- Analysis of effect of pH.

PROGRESS

we have investigated the properties of natural kaolinite nano-particles adsorbed onto a variety of surfaces (silica/mica/sapphire) of variable surface charge in ambient aqueous electrolyte. Dynamic force spectroscopy is used to calculate the interaction forces between the two facets of kaolinite and silicon AFM tip under 10 mM NaCl salt solution at constant near-neutral pH. The quantitative values of the surface charge of the two facets has been obtained by fitting the interaction forces with Poisson-Boltzmann theory with charge regulation boundary condition. We have also extended our experiments under different pH conditions as well to see the charging of the two kaolinite basal planes. Also, using the same approach, we have studied the charging behavior of mica surface under different type (Li⁺, Na⁺, Cs⁺, Ca²⁺ and Mg²⁺) and different concentration (1-100mM) of salt.

DISSERTATIONS

-

SCIENTIFIC PUBLICATIONS

1. Characterization of the surface charge distribution on kaolinite particles using high resolution atomic force microscopy. Naveen Kumar, Cunlu Zhao, Aram Klaassen, Dirk van den Ende, Frieder Mugele and Igor Siretanu, , *Geochimica et Cosmochimica Acta*, accepted, 2015.

SWITCHABLE SUPERHYDROPHOBIC SURFACES-OPTOFLUIDIC APPLICATIONS

PROJECT AIM

The objective of project is to design and characterize the optofluidic lens device by Shack Hartmann wavefront sensor (SHWS). This involves building of lens device and design and construction of optical setup. Further, experiments are to be carried out to demonstrate the suppression of spherical aberration under zero defocus condition, eventually producing perfect aspherical lens with superior optical performance. Additionally, simulations are to be carried out on optical simulation platform Zemax to corroborate the experimental data.

PROGRESS

1. Designed and build an optical setup for the wavefront characterization of optofluidic lenses. Carried out the experiment on the optofluidic lens device and recorded the pertinent data.
2. Assisted in optical numerical simulations of liquid astigmatic lenses on Zemax.
3. Performed numerical simulations of optofluidic lenses on Zemax demonstrating the suppression of spherical aberration under applied voltage.
4. Wrote a review paper on "Recent developments in optofluidics lens technology".

DISSERTATIONS

-

SCIENTIFIC PUBLICATIONS

-

PROJECTLEADERS

F Mugele

RESEARCHTHEME

Complex dynamics of fluids

PARTICIPANTS

D Baratian, A Cavalli, K Mishra,
J de Ruiter, Z Wang

COOPERATIONS

Bruno Berge, Johan Feenstra,
Jeroen van Houwelingen

FUNDED

STW	
University	-
FOM	-
STW	100 %
NWO Other	-
Industry	-
TNO	-
GTI	-
EU	-
Scholarships	-

START OF THE PROJECT

2011

INFORMATION

K Mishra
053 489 3134
k.mishra@utwente.nl
https://www.utwente.nl/tnw/pcf/people/phd_students/mishra/

EFFECTS OF SHEAR AND WALLS ON THE DIFFUSION OF COLLOIDS IN MICROCHANNELS

PROJECT LEADERS

F Mugele, MHG Duits

RESEARCH THEME

Complex dynamics of fluids

PARTICIPANTS

S Ghosh, MHG Duits

COOPERATIONS

-

FUNDED

NWO-CW

University -

FOM -

STW -

NWO Other 100 %

Industry -

TNO -

GTI -

EU -

Scholarships -

START OF THE PROJECT

2011

INFORMATION

MHG Duits

053 489 3097

m.h.g.duits@utwente.nl

http://www.utwente.nl/tnw/pcf/people/scientific_staff/MichelDuits/

PROJECT AIM

Colloidal diffusion in flow specially for concentrated systems is less explored. Previous investigations, mostly with non-Brownian suspension, suggest that the diffusivity enhances due to shear. Simultaneously, presence of a flat wall reduces particle mobility. But the interplay between shear and wall effect on particle diffusion is not addressed. Main focus is to study the effect of shear on Brownian diffusion and also how does the combination of shear and wall act together on colloidal diffusion?

PROGRESS

The role of concentration on the wall slip of colloidal suspensions was studied in microchannels with Confocal Scanning Laser Microscopy. Velocity profiles revealed slip lengths that depended only weakly on shear rate. A gradual increase of this length was found for increasing volume fraction. A theoretical model in which the particle depletion near the wall is combined with an empirical expression for the concentration dependent viscosity, described our experiments well. In another work, we studied the effect of spatial confinement on the diffusive dynamics of colloidal hard spheres at volume fractions (Φ) 0.05-0.39. Cylindrical microcavities were examined with CSLM and analyzed with particle tracking. For $\Phi > 0.28$, particles form layers along the curved wall. Diffusion in the radial direction becomes anti-correlated with the local particle density while in the azimuthal direction it remained almost independent of the structure.

DISSERTATIONS

1. Colloidal Dynamics in Flow and Confinement (defended 10 december 2015).

SCIENTIFIC PUBLICATIONS

1. Dynamics of Colloids Confined in Microcylinders, S. Ghosh, D. Wijnperlé, F. Mugele and M.H.G. Duits, *Soft Matter*, 175, (2015).
2. Measuring Advection and Diffusion of Colloids in Shear Flow, M.H.G. Duits, S. Ghosh and F. Mugele, *Langmuir* 31 (2015).
3. Effects of shear and walls on the diffusion of colloids in microchannels, S. Ghosh, F. Mugele and M.H.G. Duits, *Physical Review E* 91 (2015).

INFLUENCE-INTERFACES OF FLUID ELECTRODES: NEW CONCEPTUAL EXPLORATIONS

PROJECT AIM

Semi Solid Flow Batteries (SSFBS) present a novel solution for the grid storage of renewable energy. The interfaces between electrolyte and electrochemical particles are critical to the performance of the fluid electrodes of SSFBs. Additionally control of both mechanical and electrical properties of fluid electrode slurries is crucial. The project aims to investigate and ultimately optimize these properties.

PROGRESS

The rheological and electrical properties of SSFB electrode slurries are strongly dependent on the agglomeration behaviour of conductive carbon black particles that are added to wire electrochemically active particles. A setup capable of simultaneous electrical and rheological measurements in an air free environment (essential for lithium batteries) was developed. The effect of particle morphology, particle surface, particle volume fraction, applied shear, and shear history were then investigated on the overall electronic conductivity and mechanical strength (yield, viscoelasticity) of the slurries. From the observed behaviour, a microstructural picture was developed to help better understand and predict the performance of these slurries.

DISSERTATIONS

-

SCIENTIFIC PUBLICATIONS

-

PROJECTLEADERS

M Duits, F Mugele, Y Zhang

RESEARCHTHEME

Complex structures of fluids

PARTICIPANTS

A Narayanan, D Nguyen, MC Stuart

COOPERATIONS

KIT Munster, IREC Spain, VITO Belgium, Solvionic France, 6t-mic France

FUNDED

FP7 Program	
University	-
FOM	-
STW	-
NWO Other	100 %
Industry	-
TNO	-
GTI	-
EU	-
Scholarships	-

START OF THE PROJECT

2013

INFORMATION

MHG Duits
053 489 3097
m.h.g.duits@utwente.nl
www.utwente.nl/tnw/pcf/people/scientific_staff/MichelDuits/

SOFT MATTER, FLUIDICS AND INTERFACES



Prof.dr.ir. RGH Lammertink

Research within the Soft matter, Fluidics and Interfaces group is directed at interfacial phenomena and processes that are relevant for mass and heat transport. We wish to study and exploit fundamental principles where fluid flow encounters structures on a sub-millimeter length scale. Current topics of interest are:

ADVANCED MICROREACTORS

The fabrication and operation of dedicated microreactors, amendable to scaling are investigated. Multiphase reactor systems that incorporate membrane functionality to stabilize interfaces and perform separations are developed.

SOFT INTERFACES

Liquid-liquid and gas-liquid interfaces are crucial in many chemical processes. Interfacial phenomena, including wetting behavior, interfacial tension (gradients), interfacial curvature, are studied to gain understanding in related transport processes near these interfaces.

MICRO- AND NANOFUIDICS

This topic addresses liquid flow in confined geometries. Its relation to mass and energy transport are studied in both experimental and numerical ways. Special attention is given to boundary layer and concentration polarization phenomena.

TRANSPORT AT THE MICROSCOPIC INTERFACE

PROJECT AIM

The primary aim is the investigation of ion concentration polarization and ion-selective interfaces at the microscale, focusing on studying ion-selective nanochannels using AC impedance spectroscopy and on the use of novel nanochannel networks formed using colloidal assemblies for ion-selectivity. Combining measurements (μ PIV for the fluid flow) with ion concentration profiles and electric field distributions from simulations will elucidate the interaction between fluid flow, ion advection, diffusion, etc.. Secondly, the use of three-dimensional nanochannel networks formed from colloidal assemblies (colloidal crystals) will be investigated and analyzed using the same methodology.

PROGRESS

Currently, the microfabrication of new chips for testing colloidal crystal nanochannel networks is underway, simulation frameworks relating to predicting/understanding experimentally fabricated devices (colloidal crystals and "conventional" nanochannel arrays) have been established and the impedance analyzer system is being calibrated for on-chip measurement to incorporate AC impedance measurements into existing DC conductance and particle-image velocimetry techniques.

DISSERTATIONS

-

SCIENTIFIC PUBLICATIONS

-

PROJECT LEADERS

RGH Lammertink

RESEARCH THEME

Complex dynamics of fluids

PARTICIPANTS

J Wood

COOPERATIONS

-

FUNDED

ERC

University -

FOM -

STW -

NWO Other -

Industry -

TNO -

GTI -

EU 100 %

Scholarships -

START OF THE PROJECT

2014

INFORMATION

RGH Lammertink

053 489 2063

r.g.h.lammertink@utwente.nl

www.utwente.nl/tnw/sfi/people/staff/

lammertink

TRANSPORT AT THE MICROSCOPIC INTERFACE

PROJECT LEADERS

RGH Lammertink

RESEARCH THEME

Complex dynamics of fluids

PARTICIPANTS

S Haase

COOPERATIONS

S. Jonathan Chapman (Oxford University), Jens Harting (TU/e, University of Twente)

FUNDED

ERC	
University	-
FOM	-
STW	-
NWO Other	-
Industry	-
TNO	-
GTI	-
EU	100 %
Scholarships	-

START OF THE PROJECT

2012

INFORMATION

RGH Lammertink
053 489 2063
r.g.h.lammertink@utwente.nl
www.utwente.nl/tnw/sfi/people/staff/
lammertink

PROJECT AIM

The focus of this ERC-project lies on interfacial transport phenomena that occur in e.g. membrane processes, and in particular on those phenomena that often form a limiting factor in these processes such as concentration polarization. By investigation of these phenomena in well-defined systems, in microfluidic devices for example, we aim to acquire a deeper and more fundamental understanding of interfacial transport phenomena. The project of Sander Haase focuses on the hydrodynamical aspects of interfacial transport.

PROGRESS

In the past year, research has been focusing on (1) the Graetz-Nusselt problem for wall slip and (2) momentum transport of viscoelastic liquids over a bubble mattress. Regarding the first topic, we have numerically and analytically connected the two solutions of the classical Graetz-Nusselt forced-convection problem by extending this problem to finite, homogeneous wall slip. This has resulted in a paper (in 2015). This study is to be completed by also considering heterogeneous wall slip. An experimental study has been dedicated to the transport of shear-thinning xanthan gum solutions over a bubble mattress. The results appear to be promising, but further research is necessary. This study will be complemented by numerical simulations, which will provide more insight into the relationship between viscoelastic behavior and wall slip.

DISSERTATIONS

-

SCIENTIFIC PUBLICATIONS

1. Haase, A. S., Chapman, S. J., Tsai, P. A., Lohse, D., & Lammertink, R. G. H. (2015). The Graetz–Nusselt problem extended to continuum flows with finite slip. *Journal of Fluid Mechanics*, 764, R3. <http://doi.org/10.1017/jfm.2014.733>.

SURFACE HETEROGENEITY AND INTERFACIAL TRANSPORT

PROJECT AIM

Small-scale surface structures, both geometrically as well as chemically, can potentially influence the fluid dynamics and hence the mass transport on a microscopic scale. There is a need to understand these influences in great detail on the nano- and microscopic level, in order to couple them to the largest scales in the flow. The aim is to study catalytic surface heterogeneity with respect to interfacial transport phenomena. To obtain information, the fluid dynamics (momentum transport) and concentration profiles (mass transport) will be experimentally probed on a length scale comparable to the boundary layer.

PROGRESS

The high temperature, high pressure setup was completed. The cleanroom training was finalized as well, which made possible the fabrication of microreactors. The patterning of the sputtered layers was successful. The first step towards patterned hydrophobization was also made using a Cr mask. The testing of the sputtered ZrO₂ layers for conversion of BL into GVL using 2-butanol as a hydrogen source failed due to small surface area combined with the slow kinetics of the hydrogen transfer reaction. During a collaboration with Kamila Koichumanova from PCS group, the same reaction was tested in an ATR cell using a porous spray coated ZrO₂. The formation of GVL could be detected in the IR spectra, but only minute amounts were quantified using GC. The second part of the collaboration was regarding the 3D simulation of fluid dynamics and mass transport inside the ATR cell which is part of an article under review.

DISSERTATIONS

-

SCIENTIFIC PUBLICATIONS

-

PROJECTLEADERS

RGH Lammertink

RESEARCHTHEME

Complex dynamics of fluids

PARTICIPANTS

A Visan

COOPERATIONS

-

FUNDED

MCEC-UT-2-3

University -

FOM -

STW -

NWO Other 100 %

Industry -

TNO -

GTI -

EU -

Scholarships -

START OF THE PROJECT

2014

INFORMATION

RGH Lammertink

053 489 2063

r.g.h.lammertink@utwente.nl

www.utwente.nl/tnw/sfi/people/staff/

lammertink

TRANSPORT AT THE MICROSCOPIC INTERFACE

PROJECT LEADERS

RGH Lammertink

RESEARCH THEME

Complex dynamics of fluids

PARTICIPANTS

El Tayeb el Obied, Khalid

COOPERATIONS

-

FUNDED

ERC

University -

FOM -

STW -

NWO Other -

Industry -

TNO -

GTI -

EU 100 %

Scholarships -

START OF THE PROJECT

2013

INFORMATION

RGH Lammertink

053 489 2063

r.g.h.lammertink@utwente.nl

www.utwente.nl/tnw/sfi/people/staff/

lammertink

PROJECT AIM

The growth of bacteria in water treatment membrane units is considered as one of the most prominent challenges this technology faces. Although biofouling is the most severe form of fouling for membrane based water purification processes, no generally accepted mechanism is present. There has been significant effort in elucidating the formation and growth of biofilms inside membrane purification units. In recent microfluidic experiments, it was hypothesized that the biofilm growth is associated with subtle secondary flow patterns that exist in square shaped channels. Furthermore, extensive fluid dynamics simulations indicated that the local substrate and oxygen concentrations in biofilm covered flow channels govern the biofilm growth. Here, we seek to perform experimental investigations on the microscopic scale concerning convection and concentration profiling.

PROGRESS

In the last year we investigated the use of Optical Coherence tomography (OCT) – a technique used in the medical field- to measure velocity profiles over heterogeneous structures. OCT is a non-invasive interferometer that employs a broadband light source with a central wavelength typically around 1000nm. The back reflected light gives structural information about the sample, in our case the biofilm morphology. When adding tracer particles into the flow, two velocity components can be obtained. One from the Doppler shift parallel to the light beam, and the other from intensity fluctuations perpendicular to the light beam. The technique shows promising results when compared to numerical simulations of the flow over similar geometries in Comsol. Currently we are analyzing the results of changing flow profiles around growing biofilms in micro channels.

DISSERTATIONS

-

SCIENTIFIC PUBLICATIONS

-

TRANSPORT AT THE MICROSCOPIC INTERFACE

PROJECT AIM

The proposed experiments include the measurement of fluid flow and ion concentration, both at high precision near a membrane. In electro dialysis, an ion selective membrane is used through which ion transport is driven by an external electric field. Upon increase of the potential, a limiting and overlimiting current regime are observed. The origin of this regime is today still a topic of discussion. Under severe concentration polarization conditions, the occurrence of electroconvection phenomena is predicted. We intend to approach this problem by using controlled microfluidic experiments near ion selective materials.

PROGRESS

Design and fabrication of microfluidic chips containing nanochannels as the charge-selective interface. Experiments on concentration polarization, including DC electrical characterization, fluorescence microscopy to visualize ion concentration. Simultaneous IV-sweeps with visualization using different imposed flow fields. Chronoamperometry measurements with visualization to see build-up of the concentration polarization layer. Preliminary μ PIV measurements for flow field visualization near the charge-selective interface.

DISSERTATIONS

-

SCIENTIFIC PUBLICATIONS

-

PROJECT LEADERS

RGH Lammertink

RESEARCH THEME

Complex dynamics of fluids

PARTICIPANTS

A Benneker

COOPERATIONS

-

FUNDED

ERC

University -

FOM -

STW -

NWO Other -

Industry -

TNO -

GTI -

EU 100 %

Scholarships -

START OF THE PROJECT

2013

INFORMATION

RGH Lammertink

053 489 2063

r.g.h.lammertink@utwente.nl

[www.utwente.nl/tnw/sfi/people/staff/](http://www.utwente.nl/tnw/sfi/people/staff/lammertink)

lammertink



Prof.dr.ir. EWC van Groesen

In our group AAMP we study natural phenomena or help to design and improve technical apparatus or processes. We investigate the propagation of surface waves on a layer of fluid, the shock propagation caused by volcano eruptions through the earth, and the way how light gets reflected and transmitted through different materials.

We study these aspects with a set of suitable mathematical techniques that we extend and improve constantly. Our understanding of the phenomena is reflected in the mathematical models, which are updated and improved with increased understanding from theoretical investigations and simulations. Except for their mathematical structure with intrinsic beauty, our investigations are often 'useful': for hydrodynamic laboratories we advise how to generate the wave fields that they want to produce in their tanks to test ships in realistic situations, the calculations of seismic events may lead to an understanding which earth quakes give rise to large tsunamis, the design of optical devices with nano-scale structures helps to advance telecommunication, etc.

The topics mentioned above are very diverse in their appearance, and cover length scales ranging from 10^{-9} till 10^7 meter. The beauty of the mathematical descriptions is that they are actually quite similar: the major physical process is the evolution of waves, or an abstraction of it. Special properties that depend on the application are reflected in the mathematical structure of the wave equations that are at the basis of the models. For instance, energy or momentum conservation corresponds to symmetries in the mathematical formulations. Specific methods that we use include variational methods, which exploit the remarkable fact that often a certain optimality property can be found in the phenomenon. Except for theoretical methods, often supported with computer algebraic calculations, regularly we design larger or smaller simulation tools of a numerical nature.

For the design of these numerical schemes we aim to keep the special properties of our theoretical models as well, leading to consistent finite dimensional version of the infinite dimensional models.

The research in water waves contains various topics. Characteristic is that for irrotational flows we approach the problems in a unified consistent modelling way. This is based on the fact that upon neglecting dissipation, the full free surface equations have a basic variational structure (Luke, 1967), with the free surface equations described by a Hamiltonian system (Zakharov 1968, Broer 1974). In our modelling of specific wave fields, we exploit this structure by finding approximations of the kinetic energy part of the Hamiltonian. This is used for approximate models described by pde's like the shallow water equations, Boussinesq-, KdV and NLS-type of equations.

For numerical simulations, this structure is exploited to find consistent discretizations by variational restriction: the functionals defined on infinite dimensional spaces are restricted to finite dimensional subspaces, which may be high dimensional but may also be much more restricted by including essential properties of the phenomenon in the description, depending on the specific cases.

Within the basic approach, we include various active or passive boundary conditions, depending on the application (to generate waves by wave flaps for hydrodynamic laboratories, or bottom motions for seismic applications), or to allow a reflection-free description for calculations on numerical artificial windows. Locally, the activities are grouped in the projects Math Modelling and consistent Numerical Simulations, Free flows and Extreme Waves, Coastal Waves, and Seismic generation of waves.

WAVE MODELLING AND SIMULATION FOR OCEAN AND COASTAL ENGINEERING

PROJECT AIM

In various subprojects the variational structure of inviscid fluid dynamics is used to derive accurate and efficient numerical implementations of Boussinesq-type of equations. Hamiltonian variational wave models with exact dispersion are obtained with a spatial-spectral implementation (AB), and with a problem-dependent optimal dispersive FEM implementation (VBM). Applications deal with laboratory, coastal and oceanic waves, including harbour waves, extreme (freak) waves, and tsunamis. Extension to fully dynamic, nonlinear wave-ship interaction in a Hamiltonian Boussinesq formulation.

PROGRESS

Extended with user-friendly GUI's, the software developed over the past years is now available as HAWASSI (www.hawassi.labmath-indonesia.org) under license of LabMath-Indonesia for wave simulations. Extensions to include fully dynamic wave-ship interaction in both the AB and VBM software is under way, using a new Hamiltonian-Boussinesq formulation. Methods for wave reconstruction and future prediction from radar images of (multi-modal) seas have been extended.

DISSERTATIONS

-

SCIENTIFIC PUBLICATIONS

1. R. Kurnia & E. van Groesen, Localization in Spatial-Spectral Method for Water Wave Applications, in R.M. Kirby et al. (eds.), Spectral and High Order Methods for Partial Differential Equations ICOSAHOM 2014, Lecture Notes in Computational Science and Engineering 106, 305-313, Springer 2015.
2. R. Kurnia, T. van den Munckhof, C.P. Poot, P. Naaijen, R.H.M. Huijsmans & E. van Groesen, Simulations for design and reconstruction of breaking waves in a wavetank. OMAE 2015 Vol2,41633, 7 pages.
3. R. Kurnia & E. van Groesen, Spatial-spectral Hamiltonian Boussinesq wave simulations, Advances in Computational and Experimental Marine Hydrodynamics, VOL. 2 Conference Proceedings, 2015, pp. 19-24, ISBN: 978-93-80689-22-7.
4. A.P. Wijaya, P. Naaijen, Andonowati & E. van Groesen, Spatial evolution scenario from synthetic radar images to sea states near the radar, Ocean Engineering 106(2015)261-270.

PROJECTLEADERS

EWC van Groesen

RESEARCHTHEME

Mathematical and computational methods for fluid flow analysis

PARTICIPANTS

R Kurnia, M Hafizh, D Adytia, AP Wijaya, P Turnip, Andonowati (LabMath-Indonesia & ITB)

COOPERATIONS

LabMath-Indonesia, Bandung
Indonesia, MARIN Wageningen,
TUD Ship hydromechanics &
structures

FUNDED

STW, Labmath-Indonesia	
University	-
FOM	-
STW	45 %
NWO Other	
Industry	55 %
TNO	-
GTI	-
EU	-
Scholarships	-

START OF THE PROJECT

2012

INFORMATION

E van Groesen
053 489 3413
e.w.c.vangroesen@utwente.nl



Prof.dr.ir. JWW van der Vegt

The research in the Mathematics of Computational Science group in the Department of Applied Mathematics of the University of Twente concentrates on two main topics:

- ♦ The development, analysis and application of numerical algorithms for the (adaptive) solution of partial differential equations for problems originating from the physical and technical sciences, in particular (discontinuous Galerkin) finite element methods.

- ♦ Mathematical modeling of complex physical problems to make them accessible for computation, in particular for turbulence and geophysical problems. In order to support these activities a significant research effort is directed towards the development of hpGEM, an object oriented toolkit for finite element methods, written in C++, and suitable for high performance parallel computers. Important applications are in the fields of gas dynamics, wet chemical etching of microstructures, fluid structure interaction, two phase flows both dispersed and with free surfaces, water waves, large eddy simulation of turbulent flows, geophysical flows and computational electromagnetics. Many of these projects are conducted in close collaboration with groups in physics and chemical technology, large technological research institutes (NLR, MARIN, WL Delft Hydraulics, KNMI), and industry (DSM, AKZO and Shell).

The research is conducted in the research institute IMPACT and the research in two-phase flows is part of the UT spearhead program "Dispersed multiphase flows". The NACM group participates in the 3TU Center of Excellence for Multiscale Phenomena.

LOCAL DISCONTINUOUS GALERKIN METHODS FOR PHASE TRANSITION

PROJECT AIM

The numerical simulation of phase transition requires an accurate description of the physical phenomena at the interface between the different phases. The equations modeling phase transitions are, however, a hyperbolic-elliptic system for which standard numerical methods are not suitable. In this project, a local discontinuous Galerkin (LDG) method, enjoying conservative, stable and highly accurate properties, is considered to solve the equations describing phase transitions. Due to its local element wise discretization, the LDG method is well suited for local refinement, which is important to capture the interface accurately.

PROGRESS

Novel Local Discontinuous Galerkin (LDG) algorithms to solve the (non-) isothermal Navier-Stokes-Korteweg (NSK) equations modeling phase transition between a vapor and a liquid with a LDG method were derived, implemented and tested. Special attention was given to local mesh refinement in order to capture the thin phase transition interface more accurately and efficiently. For the time integration we use a diagonally implicit Runge-Kutta time method. The LDG algorithm was successfully tested on the merging of vapor bubbles and the interaction of vapor bubbles with a solid wall.

DISSERTATIONS

1. Tian, Lulu (2015) Local discontinuous Galerkin methods for phase transition problems. PhD thesis, University of Twente. ISBN 978-90-365-3958-6. PhD Defense 2-10-2015.

SCIENTIFIC PUBLICATIONS

1. Tian, Lulu and Xu, Yan and Kuerten, J.G.M. and van der Vegt, J.J.W. (2015) A local discontinuous Galerkin method for the (non)-isothermal Navier-Stokes-Korteweg equations. Journal of computational physics, 295. pp. 685-714.

PROJECTLEADERS

JJW van der Vegt

RESEARCHTHEME

Mathematical and computational methods for fluid flow analysis

PARTICIPANTS

L Tian, JJW van der Vegt, Y Xu (USTC, China), JGM Kuerten

COOPERATIONS

University of Science and Technology of China (USTC), Hefei, China

FUNDED

CSC Fellowship China
University -
FOM -
STW -
NWO Other -
Industry -
TNO -
GTI -
EU -
Scholarships 100 %

START OF THE PROJECT

2011

INFORMATION

L Tian
L.Tian@utwente.nl

POLYDISPERSED GRANULAR FLOWS OVER INCLINED CHANNELS

PROJECT LEADERS

JJW van der Vegt, S Luding
AR Thornton

RESEARCH THEME

Mathematical and computational
methods for fluid flow analysis

PARTICIPANTS

DR Tunuguntla

COOPERATIONS

T Weinhart

FUNDED

STW
University -
FOM -
STW 100 %
NWO Other -
Industry -
TNO -
GTI -
EU -
Scholarships -

START OF THE PROJECT

2011

INFORMATION

DR Tunuguntla
053 489 3373
D.R.Tunuguntla@utwente.nl

PROJECT AIM

The primary goal of the project is to investigate dry polydispersed, both in size and density, granular flows over inclined channels, including segregation phenomena. For this purpose, we develop a macro-scale continuum Discontinuous Galerkin Finite Element Method (DGFEM) granular flow model and couple it to a micro-scale discrete particle model (DPM). This project also runs in close collaboration with an industrial partner, Tata Steel.

PROGRESS

A new effective averaging technique called coarse graining was developed and applied to bidisperse mixtures varying both in size and density. Given the particle data such as positions, velocities and forces acting on them, one can extract the macroscopic field variables like density, velocity and stresses. The fields are no approximations as they locally satisfy the mass and momentum balance equations. By this micro-macro mapping, one could use DPMs to develop and calibrate the continuum models.

DISSERTATIONS

1. Tunuguntla, D.R. (2015) Polydisperse granular flows over inclined channels. PhD thesis, Univ. of Twente. ISBN 978-90-365-3975-32014. PhD. Defense 9-10-2015.

SCIENTIFIC PUBLICATIONS

-

Bi-disperse mixture flows flowing over a rough inclined channel.

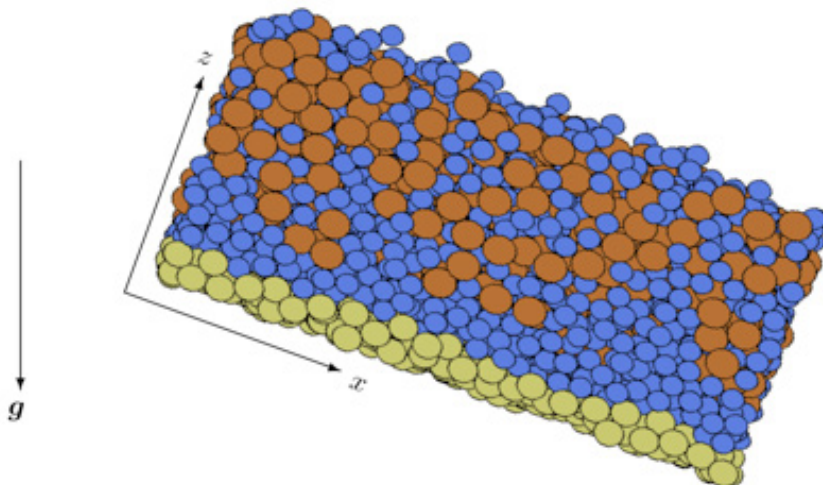

FASTFEM: BEHAVIOUR OF FAST SHIPS IN WAVES

PROJECT AIM

This project aims at developing new simulation tools to compute the dynamics of fast ships and the surrounding wave field. The waves are modeled using the potential flow water wave equation. A key element in the development of the numerical algorithm is the preservation of the underlying Hamiltonian structure after numerical discretization using a finite element method. In an earlier research project by Gagarina et al. this was accomplished for waves in a model basin with a wave maker. The challenge is now to include also a ship and the induced wave motion in the simulation model.

PROGRESS

A novel discrete variational formulation for nonlinear potential flow water waves was derived for general domains, which includes both a wave maker and a ship. Detailed mathematical proofs were given that this numerical discretization preserves the Hamiltonian structure of the potential flow water wave equations, even on general unstructured meshes. Also, a new method to deal with general mesh deformation in combination with the Hamiltonian discretization was derived. The algorithms have been implanted and tested the MACS finite element toolkit hpGEM. Initial results are looking promising and demonstrate that there is no numerical dissipation in the wave motion, even on highly distorted unstructured meshes.

DISSERTATIONS

-

SCIENTIFIC PUBLICATIONS

-

PROJECTLEADERS

JJW van der Vegt

RESEARCHTHEME

Mathematical and computational methods for fluid flow analysis

PARTICIPANTS

F Brink, JJW van der Vegt

COOPERATIONS

R.H.M. Huijsmans, TU Delft, Damen Ship Yards, MARIN, Royal Netherlands Navy, Bureau Veritas, Lloyds Register, Royal Netherlands Rescue Organization

FUNDED

STW	
University	-
FOM	-
STW	66 %
NWO Other	-
Industry	33 %
TNO	-
GTI	-
EU	-
Scholarships	-

START OF THE PROJECT

2014

INFORMATION

JJW van der Vegt

j.j.w.vandervegt@utwente.nl

wwwhome.math.utwente.nl/~vegtjjw/

MULTISCALE MODELING & SIMULATION



Prof.dr.ir. BJ Geurts



Prof.dr. JGM Kuerten

I am a scientist, trained as theoretical physicist and applied mathematician, holding the chair for Multiscale Modeling and Simulation at the University of Twente and for Anisotropic Turbulence at Eindhoven University of Technology. My research focus is on mathematics, physics and numerics of multiscale problems in turbulence, mixing, complex fluids and biology. I try to find simplicity behind complexity, find structures and what combines, rather than what separates. I contribute to 3TU.AMI, ERCOFTAC, TGS Computational Science and act as HoD of Applied Mathematics in Twente.

MULTI-SCALE MODELING AND SIMULATION OF AEROSOL NUCLEATION

PROJECT AIM

In this project, we develop a model for the description of aerosol droplet production, evolution and transport. The goals are 1) to identify a suitable aerosol model which is capable of predicting aerosol size distributions and composition, depending on processes such as nucleation, condensation, coagulation and deposition and 2) to develop effective numerical methods to find, within reasonable computational time, a solution to the aerosol model, in 3D flow.

PROGRESS

In the past year a sectional formulation of an aerosol model was developed. The size distribution of aerosol droplets is represented by a number of discrete droplet sizes, or sections. The governing equations are solved with respect to these sections. A characteristics method was developed which is 1) robust and does not contain a severe time step restriction and 2) accurate as a pre-defined number of moments of the size distribution may be preserved. The method was applied to the development of an aerosol in a driven cavity flow and later extended to capture flow in a bend pipe. In the latter case the deposition of aerosol droplets on the walls of the flow domain was predicted and compared to literature.

DISSERTATIONS

-

SCIENTIFIC PUBLICATIONS

1. Extension of the compressible PISO algorithm to single-species aerosol formation and transport EMA Frederix, M Stanic, AK Kuczaj, M Nordlund, BJ Geurts. International Journal of Multiphase Flow 74, 184-194 (2015)

PROJECT LEADERS

BJ Geurts

RESEARCH THEME

Mathematical and computational methods for fluid flow analysis

PARTICIPANTS

EMA Frederix, AK Kuczaj

COOPERATIONS

Philip Morris International

FUNDED

Philip Morris International S.A.

University	-
FOM	-
STW	-
NWO Other	-
Industry	100 %
TNO	-
GTI	-
EU	-
Scholarships	-

START OF THE PROJECT

2012

INFORMATION

E Frederix
06 46618936
e.m.a.frederix@utwente.nl
www.utwente.nl/ewi/mms

COMPUTATIONAL MODELING OF BOILING FLOW REGIME MAPS

PROJECT LEADERS

BJ Geurts

RESEARCH THEME

Mathematical and computational methods for fluid flow analysis

PARTICIPANTS

P Cifani, JGM Kuerten

COOPERATIONS

GJM Priem, WR Michalek, CWM van der Geld (TUE)

FUNDED

STW	
University	-
FOM	-
STW	90 %
NWO Other	-
Industry	10 %
TNO	-
GTI	-
EU	-
Scholarships	-

START OF THE PROJECT

2013

INFORMATION

P Cifani
053 489 3414
p.cifani@utwente.nl
www.utwente.nl/ewi/mms/

PROJECT AIM

For the design of evaporator tubes used in various types of conventional power plants, medium-size boilers and waste incinerators, knowledge of flow pattern changes under the influence of external heating is of utmost importance to warrant safe operation. The project is focused on the development and validation of a numerical method based on a multi-scale approach to boiling flows. The proposed research will produce a validated, reliable and versatile prediction tool as well as a set of practical flow pattern maps for heated two-phase flows.

PROGRESS

A two-phase flow model with phase-change was successfully implemented in the open source CFD tool OpenFOAM. A kinetic-based mass transfer rate was adopted and compared to a balance model. As a main result, several simulations of a rising bubble with mass and heat transfer in a viscous liquid were carried out. A paper was prepared and submitted for publication – it will appear in 2016. Extensions to vapor bubbles in turbulent flow are constructed.

DISSERTATIONS

-

SCIENTIFIC PUBLICATIONS

-

LARGE SCALE COMPUTATIONS OF RAYLEIGH-BÉNARD CONVECTION

PROJECT AIM

We aim to develop an efficient numerical method for direct numerical simulations of Rayleigh-Bénard convection. Turbulent flows at high Rayleigh numbers are challenging to solve numerically and require long computing times, even on today's large supercomputers. Current numerical solvers are limited in the number of processors that can be used efficiently. By parallelizing the problem in time, in addition to a traditional parallelization in space, we may deploy many more processors in parallel and reduce the computing time significantly.

PROGRESS

We analyzed the performance and accuracy of the open-source spectral element method Nek5000 for simulations of Rayleigh-Bénard convection. We found good agreement with the finite volume method, which is being used by various groups working in the field of Rayleigh-Bénard convection. The theoretical basis of the time-parallel method was developed and illustrated for a one-dimensional setting. Extensions to 2d are being completed and presented as publication.

DISSERTATIONS

-

SCIENTIFIC PUBLICATIONS

1. Direct numerical simulation of Nusselt number scaling in rotating Rayleigh-Bénard convection. GL Kooij, MA Botchev, BJ Geurts. International journal of heat and fluid flow 55, 26-33 (2015).
2. A Block Krylov Subspace Implementation of the Time-Parallel Paraexp Method and its Extension for Nonlinear Partial Differential Equations. GL Kooij, MA Botchev, BJ Geurts. arXiv preprint arXiv:1509.04567 (2015).

PROJECTLEADERS

BJ Geurts

RESEARCHTHEME

Mathematical and computational methods for fluid flow analysis

PARTICIPANTS

G Kooij, M Botchev

COOPERATIONS

Dr. Rudie Kunnen (TUE)

FUNDED

FOM	
University	-
FOM	100 %
STW	-
NWO Other	-
Industry	-
TNO	-
GTI	-
EU	-
Scholarships	-

START OF THE PROJECT

2013

INFORMATION

G Kooij

g.l.kooij@utwente.nl

www.utwente.nl/ewi/mms/



Prof.dr.ir. CH Venner



Prof.dr.ir. HWM Hoeijmakers

Modern engineering challenges concern the design and development of processes and equipment with a high performance and minimal environmental impact, i.e. effective use of resources, energy and minimal generation of waste products and noise. The Engineering Fluid Dynamics group aims to contribute to innovative solutions for practically relevant societal, environmental and industrial challenges by bringing “fundamental” physics to actual applications on many scales, ranging from large size high power such as aircraft parts, compressors, and turbines, to small-scale thin-layer free surface flows in lubrication and bearing applications. The research is both experimental and theoretical, including numerical simulations with in house development of accurate numerical codes and multilevel/multigrid computational methodologies. The research focuses on the following themes:

Fluid Mechanics of Rotating Flow Machines

The flow in centrifugal pumps, compressors, and around wind turbine blades. The research involves optimization of the functional aspects (blade/impeller geometry, cavitation characteristics, efficiency, active flow control) as well as the minimization of non-drag related energy losses in the lubrication and transition layers, and minimization of environmental aspects such as the reduction of vibrational and (aeroacoustic) noise. For this purpose, an aeroacoustic test facility is used: A silent closed circuit wind tunnel with a (0.7x0.9 m²) free-jet test-section (maximum velocity 65 m/s) which is enclosed by a 6x6x4m³ anechoic chamber.

Multi-phase flows and wave phenomena

Flows with phase transition occur in many engineering applications such as flow of oil/water/gas mixtures in hydrocarbon transport lines, ice accretion on aircraft wings in flight, flows with cavitation, separation of mixtures, and dense-phase fluid particle flows in dredging applications. The group develops computational methods for specific applications aimed at actual design and prototyping and also carries out fundamental studies, on the mechanisms of e.g. condensation, in multiphase systems. Research is also carried out aimed at identifying the acoustic signature of the flow.

Computational Aerodynamics Algorithm Design

Practical applications in engineering involve the occurrence of phenomena on largely different scales in almost any application. In such cases both high order accuracy as well as computational efficiency are of the utmost importance. The group develops and tests numerical algorithms for simulation and optimization, and validates predictions for actual applications ranging from Navier Stokes and Euler equations to potential flows, and reduced systems such as lubrication flows with combined elasticity on nano-scale. Aspects of development are high order compact schemes, multigrid/multilevel computational methodologies and gradient based adjoint optimization.

Bio-physical flows

This research deals with the flow in (bio)medical and natural systems. Projects include flow in lungs (aerosol deposition), medical sprays, and separation of specific cell rich flows. Research is aimed at developing new (computational) diagnostic and therapeutic tools. Research in nature-inspired flows is aimed at the development of robot-birds and minimizing the impact of technology on the natural environment.

HAIC, HIGH ALTITUDE ICE CRYSTALS

PROJECT AIM

Numerical simulation of ice accretion in the first stages of a compressor of an aircraft engine due to the presence of ice crystals at high altitude. The Eulerian approach for predicting the droplet trajectories will be used, combined with the (modified) Messinger model for the actual ice accretion.

PROGRESS

The Eulerian method for ice crystal trajectories has been extended to accommodate heat transfer and phase change for non-spherical ice crystals. Three additional conservation equations are now solved in addition to particle mass and momentum. The energy equation governs particle heating, evaporation and melting. The two remaining equations govern the liquid fraction, in the form of melt water, and the change in particle number density, which is related to the particle size.

Furthermore, progress has been made on the treatment of secondary clouds containing particles that result from bouncing or shattering particles on impact with a surface. Implementation of the secondary particles as a separate Eulerian computation with inlet conditions on the surface of the body is well advanced.

DISSERTATIONS

-

SCIENTIFIC PUBLICATIONS

1. E. Iuliano, E. Montreuil, E. Norde, E.T.A. van der Weide, H.W.M. Hoeijmakers, Modelling of Non-Spherical Particle Evolution for Ice Crystals Simulation with an Eulerian Approach, June 2015, SAE 2015-01-2139, Prague, Czech Republic.
2. E.J. Grift, E. Norde, E.T.A. van der Weide, H.W.M. Hoeijmakers, Computational Method for Ice Crystal Trajectories in a Turbofan Compressor, June 2015, SAE 2015-01-2138, Prague, Czech Republic.

PROJECTLEADERS

HWM Hoeijmakers, CH Venner,
ETA van der Weide

RESEARCHTHEME

Mathematical and computational
methods for fluid flow analysis

PARTICIPANTS

E Norde, ETA van der Weide, HWM
Hoeijmakers

COOPERATIONS

Onera, CIRA, Airbus Group
Innovations, Darmstadt Univ., TAI,
INCAS, TsAGI

FUNDED

EU	
University	25 %
FOM	-
STW	-
NWO Other	-
Industry	-
TNO	-
GTI	-
EU	75 %
Scholarships	-

START OF THE PROJECT

2013

INFORMATION

ETA van der Weide
053 489 2593
e.t.a.vanderweide@utwente.nl

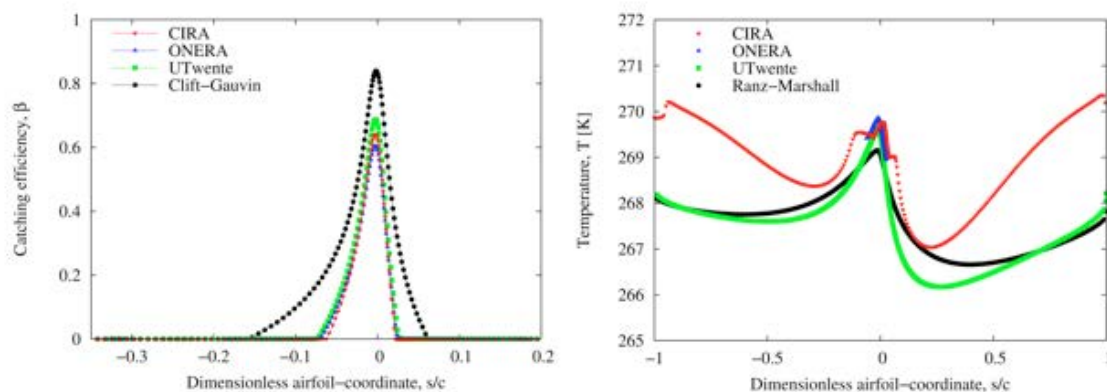

Catching efficiency (left) and particle temperature along the surface (right) of a non-spherical, disk-shaped particle, with a diameter of 100 μm and an aspect ratio of 0.1, impacting on a NACA-0012 airfoil. The catching efficiency and particle temperature are compared for three Eulerian methods developed by CIRA, Onera and University of Twente. The black lines are reference results obtained for spherical particles.

PREDICTION OF THE HYDRAULIC PERFORMANCE OF CENTRIFUGAL PUMPS AND FANS

PROJECT LEADERS

NP Kruyt, CH Venner

RESEARCH THEME

Mathematical and computational methods for fluid flow analysis

PARTICIPANTS

RW Westra, NP Kruyt, K van Anandel, HWM Hoeijmakers

COOPERATIONS

Flowserve BV

FUNDED

Senter, UT	
University	100 %
FOM	-
STW	-
NWO Other	-
Industry	-
TNO	-
GTI	-
EU	-
Scholarships	-

START OF THE PROJECT

1998

INFORMATION

NP Kruyt
053 489 2528
n.p.kruyt@utwente.nl

PROJECT AIM

The hydraulic performance of pumps is studied both numerically and experimentally. For the numerical flow simulation, a potential-flow method has been developed for the flow inside centrifugal, mixed-flow pumps as well as axial pumps and fans. The method includes loss models and a cavitation inception model. The method has been extended to include a transpiration-type of model for the effect of sheet cavitation. The experimental work is carried out in the new Rotating Flow facility.

PROGRESS

In 2015 some further work has been carried out. realized. The Rotating Flow facility is being redesigned so that higher rotational speeds become possible. An associated project has been completed that deals with fish-friendliness of centrifugal pumps.

DISSERTATIONS

-

SCIENTIFIC PUBLICATIONS

1. Krakkers, L.A. & Kruyt, N.P. & Rutjes, C. (2015). Full-scale validation of a comprehensive criterion to predict fish-friendliness of pumps. ASME-JSME-KSME Joint Fluids Engineering Conference 2015, Paper AJK2015-16450, Seoul, Korea.

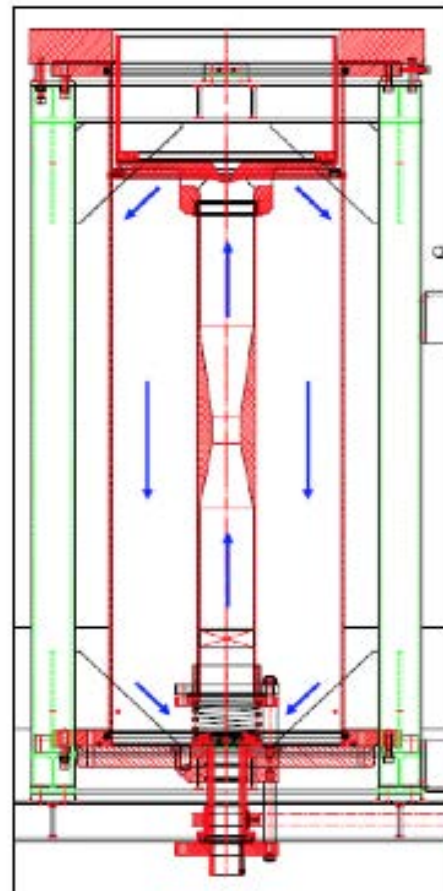
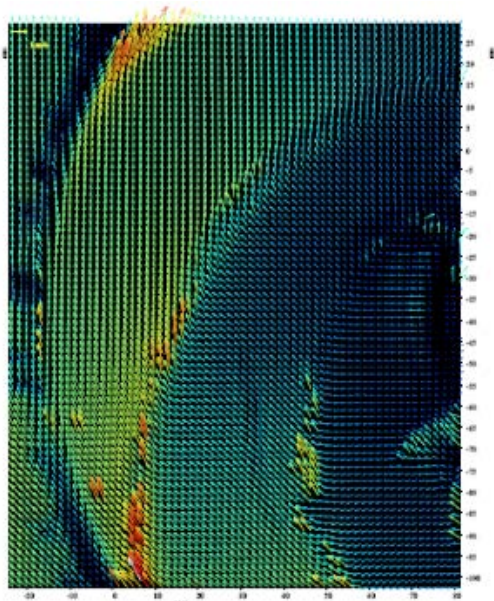

INVERSE DESIGN AND OPTIMISATION METHODS FOR CENTRIFUGAL PUMPS AND FANS

PROJECT AIM

Using the augmented potential-flow method developed for the prediction of the hydraulic performance of centrifugal and mixed flow pumps, two types of design methods for three-dimensional configurations are investigated: (i) inverse-design methods and (ii) optimization methods. The validation of the computational methods has been carried out in the newly developed Rotating Flow facility, by PIV-measurements of the relative velocity field.

PROGRESS

A three-dimensional inverse-design method for impellers of centrifugal pumps has been developed, by which an impeller geometry is obtained that meets the prescribed hydraulic characteristics (rotational speed, flow rate, head and loading). Optimisation methods have been developed in which the performance of centrifugal pump impellers is optimised with respect to required head, low losses and optimal cavitation characteristics. The relative velocity field has been measured at various operating conditions using PIV, in the newly developed Rotating Flow facility. Publications have been effected.

DISSERTATIONS

-

SCIENTIFIC PUBLICATIONS

-

PROJECTLEADERS

NP Kruyt, CH Venner

RESEARCHTHEME

Mathematical and computational methods for fluid flow analysis

PARTICIPANTS

RW Westra, NP Kruyt, K van Anandel

COOPERATIONS

Flowsolve BV, Urenco Aerospace, Johnson Pump, IHC Parts & Services, NLR, Marin

FUNDED

STW, UT	
University	-
FOM	-
STW	100 %
NWO Other	-
Industry	-
TNO	-
GTI	-
EU	-
Scholarships	-

START OF THE PROJECT

2003

INFORMATION

NP Kruyt
053 489 2528
n.p.kruyt@utwente.nl



AERODYNAMICS OF FLEXIBLE WIND TURBINE BLADES

PROJECT LEADERS

HWM Hoeijmakers, A Hirschberg

RESEARCH THEME

Mathematical and computational methods for fluid flow analysis

PARTICIPANTS

ETA van der Weide, HWM Hoeijmakers

COOPERATIONS

ECN, JAXA

FUNDED

ECN, UT	
University	30 %
FOM	-
STW	-
NWO Other	-
Industry	-
TNO	-
GTI	70 %
EU	-
Scholarships	-

START OF THE PROJECT

2000

INFORMATION

HWM Hoeijmakers
053 489 4838
h.w.m.hoeijmakers@utwente.nl

PROJECT AIM

CFD methods for unsteady flows are developed for the aero-elastic behavior of flexible wind turbine blades. The methods considered range from inviscid flow methods coupled to boundary-layer methods to time-accurate RANS methods. The flow conditions to be considered include cases with dynamic stall. Means for flow control are explored, both experimentally and computationally.

PROGRESS

In 2015 experimental research has been conducted on means for flow control: synthetic jets (SJA's) and Plasma Actuators (PA's). Using piezo-electric elements for SJA's it is now possible to achieve maximum outflow velocities up to 60 m/s. These have been employed in a set-up for flow-separation control as well as in a set-up for load control. Experimental work on PA's have been continued in the direction of exploring nanopulse Plasma Actuators. Preliminary measurements have been performed using flow visualisation in order to detect the structure of the flow field induced by the nanopulse PA.

DISSERTATIONS

-

SCIENTIFIC PUBLICATIONS

1. T. Bouwhuis, Y. Abe, A. Yakeno, T. Nonomura, H. Hoeijmakers and K. Fujii
Basic Research for Proposal of a New Simple DBD-Plasma Actuation Model
Third Symposium of Plasma Actuator Study Group, JSME4, December 4, 2015, Tottori, Japan.
2. B. Wahjudi, S. Soeparman and H. Hoeijmakers. Optimization Design of Savonius Diffuser Blade with Moving Deflector for Hydrokinetic Cross Flow Turbine Rotor Energy Procedia 04/2015, Vol. 68, 2015. DOI: 10.1016/j.egypro.2015.03.253.

PRESSURE CONTROLLED HIGH-FLOW THERAPY FOR AIRWAY INFECTIONS

PROJECT AIM

Severe airway infections in infants are increasingly treated by non-invasive high-flow nasal cannula (HFNC) therapy which provides a flow-rate controlled increase of airway pressure and prevents respiratory insufficiency. However, there is a large uncertainty in the generated pressure level which has received world-wide attention over the last decade. To remove this uncertainty we propose to investigate the feasibility of switching from flow rate controlled therapy to pressure controlled therapy. If successful, this will lead to increased efficiency and effectiveness, reduced risk, and possibly to reduced costs up to 2.5 - 10 M€ for the Netherlands.

PROGRESS

The project just started, in-vitro measurements are initiated.

DISSERTATIONS

-

SCIENTIFIC PUBLICATIONS

-

PROJECTLEADERS

R Hagmeijer, CH Venner

RESEARCHTHEME

Complex dynamics of fluids

PARTICIPANTS

R Hagmeijer (UT), B Thio (MST),
J Goorhuis (MST)

COOPERATIONS

National cooperation, Pioneers in Health Care, Innovatiefonds 2015

FUNDED

ZGT, MST, UT

University 50 %

FOM -

STW -

NWO Other -

Industry 50 %

TNO -

GTI -

EU -

Scholarships -

START OF THE PROJECT

20015

INFORMATION

R Hagmeijer

053 489 5605

r.hagmeijer@utwente.nl

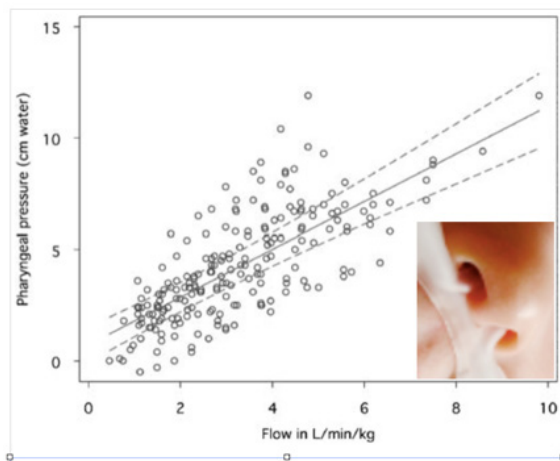

Wide spread in nasal cavity pressure levels of 18 premature infants during HFNC-therapy at various flow rates [Wilkinson et al., J. Perinatol, 28, 2008]

SMART FIXED WING AIRCRAFT, WP 1.3.8

PROJECT LEADERS

HWM Hoeijmakers, ETA van der Weide

RESEARCH THEME

Mathematical and computational methods for fluid flow analysis

PARTICIPANTS

ETA van der Weide, HWM Hoeijmakers

COOPERATIONS

-

FUNDED

EU (CleanSky Project)	
University	50 %
FOM	-
STW	-
NWO Other	-
Industry	-
TNO	-
GTI	-
EU	50 %
Scholarships	-

START OF THE PROJECT

2009

INFORMATION

ETA van der Weide
053 489 2593
e.t.a.vanderweide@utwente.nl

PROJECT AIM

Investigate the possibility to apply synthetic jet flow control on the flaps of aircraft wings in order to increase the lift during take off and landing. The goal of this research is to determine the specifications of a synthetic jet flow control device in order to accomplish the desired effects.

PROGRESS

In 2015 this program was finished and a final report has been written together with TU Delft and NLR.

DISSERTATIONS

-

SCIENTIFIC PUBLICATIONS

-

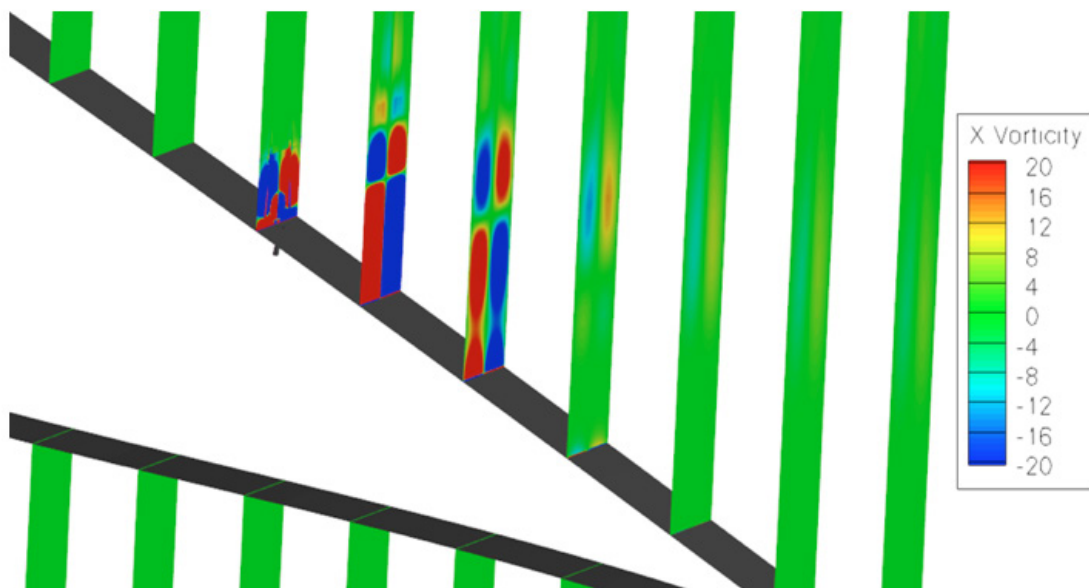

X-vorticity distribution at several cross-sections for Mach = 0.2, Reynolds = $3 \cdot 10^6$ and angle of attack of 11 degrees. The actuation takes place at 75 percent of the chord with a differential pressure of 500 mbar.

Ω^2 R SWIRL SEPARATOR II – TOWARDS APPLICATION

PROJECT AIM

We aim to demonstrate the capabilities of in-line oil/water separation technology based on swirl and we aim to mature the technology such that it is suitable for field trials. This project focuses on the water treatment case: clean water (<2000 ppm oil) needs to be extracted from the oil/water mixture. The following aspects will be taken into account to determine the design for a prototype: single phase SPIV experiments near the oil outlet, pressure measurements, and numerical simulations. This will allow us to choose an optimal prototype and predict its operating envelope and separation characteristics.

PROGRESS

Numerical studies using 2D calculations have been used to form a model predicting the separation characteristics of the device as a function of geometrical and process parameters. Current work focuses on 3D simulations to match SPIV experiments and enhance predictions.

DISSERTATIONS

-

SCIENTIFIC PUBLICATIONS

-

PROJECTLEADERS

HWM Hoeijmakers, CH Venner

RESEARCHTHEME

Complex dynamics of fluids

PARTICIPANTS

JM Hospers

COOPERATIONS

TU Delft

FUNDED

ISPT (Institute for Sustainable Process Technology)

University -

FOM -

STW -

NWO Other -

Industry 100 %

TNO -

GTI -

EU -

Scholarships -

START OF THE PROJECT

2014

INFORMATION

J Hospers

053 489 2593

j.m.hospers@utwente.nl

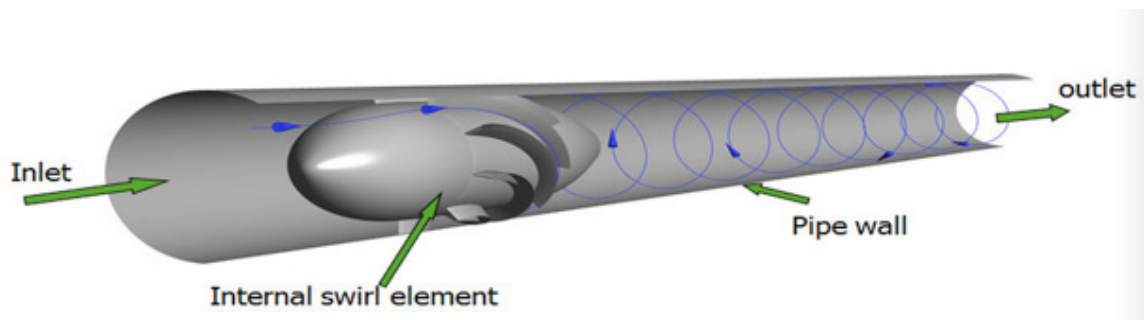

REVISITING ARGON CLUSTER FORMATION IN A PLANAR GAS JET FOR HIGH-INTENSITY LASER MATTER INTERACTION

PROJECT LEADERS

R Hagmeijer, CH Venner

RESEARCH THEME

Complex dynamics of fluids

PARTICIPANTS

R Hagmeijer, ETA van der Weide, HMJ Bastiaens, K-J Boller, Y Tao

COOPERATIONS

-

FUNDED

STW (PhDproject), University of Twente (RH & ETAvdW)

University 100 %

FOM -

STW -

NWO Other -

Industry -

TNO -

GTI -

EU -

Scholarships -

START OF THE PROJECT

2014

INFORMATION

R Hagmeijer

053 489 5605

r.hagmeijer@utwente.nl

PROJECT AIM

We determine the size of argon clusters generated with a planar nozzle, based on optical measurements in conjunction with theoretical modelling. Using a quasi-one dimensional model for the moments of the cluster size distribution, we determine the influence of critical physical assumptions. We use the calculated value for the liquid mass fraction to retrieve the cluster size from optical measurements, i.e., calibrated Rayleigh scattering and interferometry.

PROGRESS

A new power law for higher values of the Hagen parameter $\Gamma^* > 10^4$ has been derived, which is of relevance for experiments on high-intensity laser matter interactions.

DISSERTATIONS

-

SCIENTIFIC PUBLICATIONS

1. "Revisiting argon cluster formation in a planar gas jet for high-intensity laser matter interaction", by Y. Tao, R. Hagmeijer, E. T. A. van der Weide, H. M. J. Bastiaens, and K.-J. Boller, submitted to Journal of Applied Physics, revision-phase.

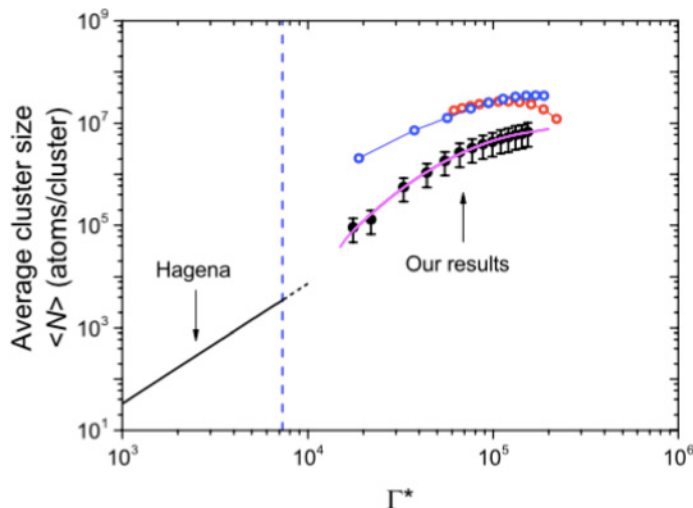

COPA-GT, STUDY OF HIGHER ORDER ENERGY-STABLE DISCRETIZATION TECHNIQUE FOR TURBOMACHINERY APPLICATIONS

PROJECT AIM

The research is theoretical/numerical and focuses on the development of an highly efficient parallel multiblock structured code for turbomachinery applications. The goal is to assess whether or not high order energy stable schemes are more efficient for such problems. In fact, the most widely used commercial codes typically provide a 2nd order accurate discretization of the Navier-Stokes equations. The question is if it possible to obtain the same solution making use of high order (≥ 3 rd) numerical methods and at the same time reducing the number of points of the numerical grid. This would lead to large saving in terms of computational time.

PROGRESS

The implementation of the (fully implicit) RANS solver has been completed. It has been tested on several classical test cases, like the Rotor37, a transonic axial compressor designed by NASA, and the Aachen turbine, a 1 and half stage subsonic turbine (see figures below). The ESDIRK schemes have been used for the time integration of the unsteady flow in the Aachen turbine. While reasonable results have been obtained, these complex test cases highlighted the current limitation of the energy-stable high-order schemes we are using. Features like shock-capturing, proper boundary conditions for internal flows, and generalized interpolation operators are missing in the mathematical framework. Nevertheless, these schemes turned out to be very efficient for smooth external flows in relatively simple geometries. The developed code is particularly well suited for inviscid, DNS and LES simulations for which explicit and implicit time-stepping can be used.

DISSERTATIONS

-

SCIENTIFIC PUBLICATIONS

1. Unsteady simulations of rotor stator interactions using SBP-SAT schemes: status and challenges, Giangaspero, Almquist, Mattsson, van der Weide. In Spectral and High Order Methods for Partial Differential Equations ICOSAHOM 2014, volume 106 of the book series 'Lecture Notes in Computational Science and Engineering'. Springer, 2015.
2. A stable and conservative high-order solver for the Reynolds-Averaged Navier-Stokes equations. Giangaspero, van der Weide. Proceedings of YIC GACM 2015, Aachen, Germany.
3. Efficiency benchmarking of an energy stable high-order finite difference discretization, van der Weide, Giangaspero, Svard. AIAA Journal, Vol. 53, No. 7 (2015), pp. 1845-1860. doi: 10.2514/1.J053500.

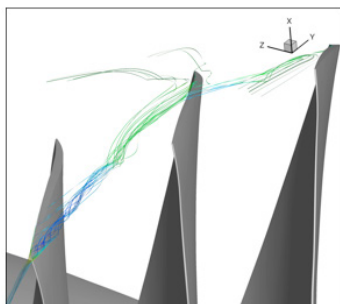

Rotor37 (NASA), tip leakage vortex

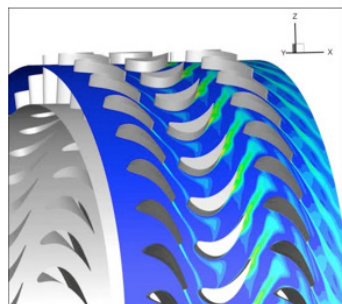

Aachen Turbine, contours of entropy at 75% span

PROJECTLEADERS

HWM Hoeijmakers, ETA van der Weide

RESEARCHTHEME

Mathematical and computational methods for fluid flow analysis

PARTICIPANTS

G Giangaspero, ETA van der Weide, HWM Hoeijmakers

COOPERATIONS

VKI, Cerfacs, RWT, Turbomeca, BSC, Siemens, Loughborough Univ

FUNDED

EU	
University	25 %
FOM	-
STW	-
NWO Other	-
Industry	-
TNO	-
GTI	-
EU	75 %
Scholarships	-

START OF THE PROJECT

2012

INFORMATION

ETA van der Weide
053 489 2593
e.t.a.vanderweide@utwente.nl

DEVELOPMENT OF FLUID-STRUCTURE INTERACTION CAPABILITIES IN REFRESCO

PROJECT LEADERS

ETA van der Weide, CH Venner

RESEARCH THEME

Mathematical and computational methods for fluid flow analysis

PARTICIPANTS

SH Jongsma, ETA van der Weide, HWM Hoeijmakers

COOPERATIONS

UT, MARIN

FUNDED

MARIN

University -

FOM -

STW -

NWO Other -

Industry -

TNO -

GTI 100 %

EU -

Scholarships -

START OF THE PROJECT

2014

INFORMATION

ETA van der Weide

053 489 2593

e.t.a.vanderweide@utwente.nl

PROJECT AIM

The aim of this project is to develop a method that can be used for performing fluid-structure interaction simulations for maritime applications. For this purpose, a coupling must be realized between the finite-volume flow solution method for incompressible flows, called ReFRESCO, and a method for modeling and discretization of a deformable structure. The corresponding equations of motion for the structure must subsequently be solved together with the equations describing the flow.

PROGRESS

First, the coupling between ReFRESCO and a finite-element method for modeling and discretization of the structure has been realized. Subsequently, different time-integration methods for integrating the equations of motion for the structure in time have been implemented. For coupling of the fluid domain and the structure, a strongly coupled approach is adopted, which means that the fluid-structure interface shape is computed iteratively, until an equilibrium state is reached. An interface coupling method has been created, which takes into account the so-called added mass effect. By taking this effect into account, fewer coupling iterations are required and a more robust algorithm is achieved. A parallel implementation of the method has been realized, such that the method can efficiently be applied on a cluster.

DISSERTATIONS

-

SCIENTIFIC PUBLICATIONS

1. S. H. Jongsma and J. Windt, Towards Fluid-Structure Interaction Simulations in a Finite-Volume Flow Solution Method, NuTTS 2015.

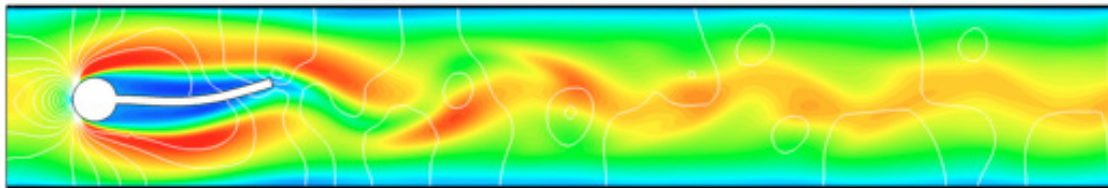

DYNVOR : THE DYNAMICS OF VORTEX CAVITATION ON SHIP PROPULSORS AND PUMP IMPELLERS

PROJECT AIM

The aim of this project is: (i) to enhance the understanding of the contribution of cavitating vortices to cavitation vibration and cavitation erosion and (ii) to develop a simulation code capable of predicting flows with cavitating vortices. It is believed that Large Eddy Simulation (LES) for the modeling of turbulence is a key tool for the success of such a simulation code. Typical applications where this type of flow occurs are flows around ship propulsors and flows in pumps.

PROGRESS

In 2015 this program was finished by completing and defending the thesis.

DISSERTATIONS

1. F. Khatami. Numerical Simulation of the Dynamics of Vortex Cavitation.

SCIENTIFIC PUBLICATIONS

1. F. Khatami, E. van der Weide and H. Hoeijmakers. Multi-Phase Thermodynamic Tables for Efficient Numerical Simulation of Cavitating Flows: a Novel Look-up Approach towards Efficient and Accurate Tables. Heat Transfer Engineering Journal (HTE), Vol. 36, No. 12, January 2015, pp. 1065-1083.
2. F. Khatami, E. van der Weide and H. Hoeijmakers. Compressible Turbulent Flow Numerical Simulation of Tip Vortex Cavitation. CAV 2015 Conference, Lausanne, Switzerland.
3. T. Hommes, J. Bosschers and H. Hoeijmakers. Evaluation of the Radial Pressure Distribution of Vortex Models and Comparison with Experimental Data CAV2015 Conference, Lausanne, Switzerland.

PROJECTLEADERS

HWM Hoeijmakers, ETA van der Weide

RESEARCHTHEME

Mathematical and computational methods for fluid flow analysis

PARTICIPANTS

F Khatami, ETA van der Weide, HWM Hoeijmakers

COOPERATIONS

Wärtsilä, IHC Merwede, Flowserve

FUNDED

AgentschapNL
University -
FOM -
STW -
NWO Other -
Industry 25 %
TNO -
GTI -
EU 75 %
Scholarships -

START OF THE PROJECT

2011

INFORMATION

ETA van der Weide
053 489 2593
e.t.a.vanderweide@utwente.nl

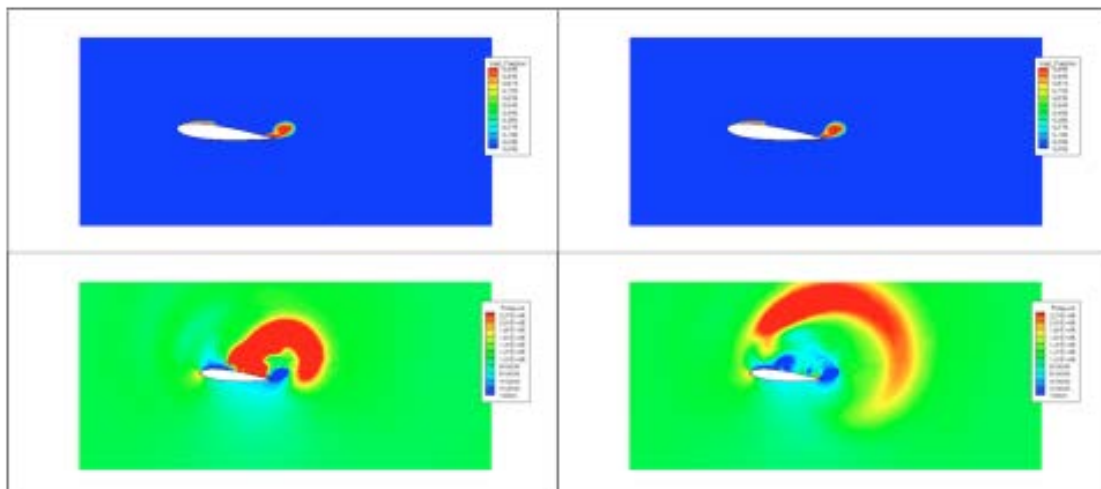

Void fraction and pressure during the implosion of the void.

ILLUMINATING FUNDAMENTAL ASPECTS OF SUPERSONIC FLOWS

PROJECT LEADERS

CH Venner, HWM Hoeijmakers

RESEARCH THEME

Complex dynamics of fluids

PARTICIPANTS

E Giskes, L deSantana

COOPERATIONS

University of Twente, Optical Sciences.

FUNDED

University	100 %
FOM	-
STW	-
NWO Other	-
Industry	-
TNO	-
GTI	-
EU	-
Scholarships	-

START OF THE PROJECT

2015

INFORMATION

CHVenner
053 489 2488
c/h.venner@utwente.nl

PROJECT AIM

Development of short time pulse LED driven Schlieren methodology, using state-of-the art electrical and optical components. The Schlieren method has been designed, realized and demonstrated to be feasible for exploring fundamental aspects of highly unsteady flow phenomena and structures in supersonic flow. It has been applied to jet injection in cross-flow, a model for SCRAM jet engines. The Schlieren system can be exploited for analysis and for generating data for validation of results of computational methods.

PROGRESS

A LED driven fast Schlieren system has been developed. Illumination times of 750 nanoseconds were shown to be sufficient to capture detailed Schlieren images in a flow at a Mach number of 1.7. The system was used to determine penetration depth and variation of flow structures in a jet injection in a supersonic cross flow. The system allows use of dual-pulsed imaging to obtain time correlated data which is currently further developed.

DISSERTATIONS

-

SCIENTIFIC PUBLICATIONS

-

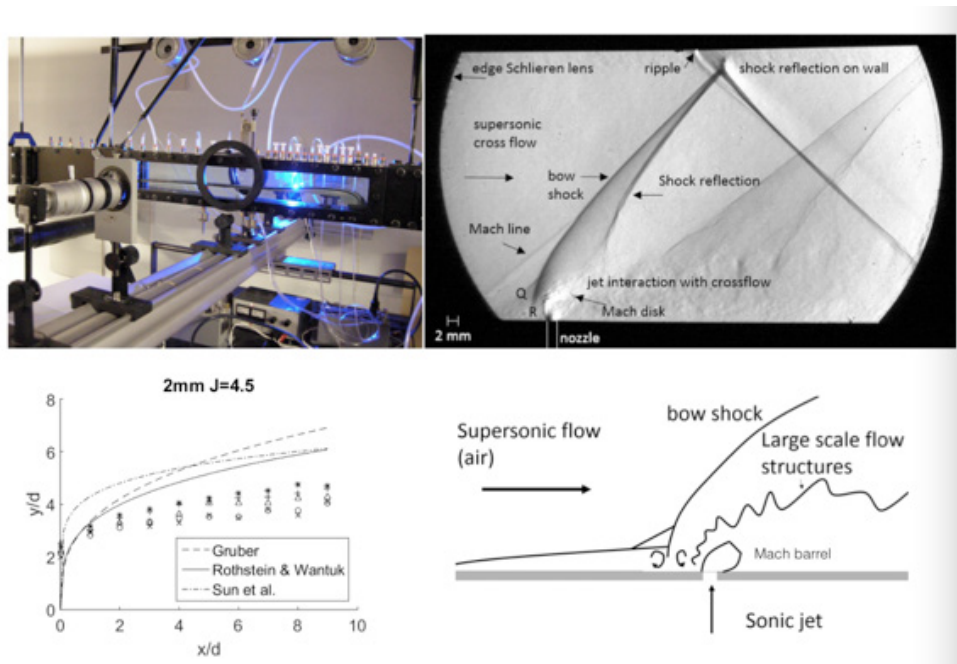

Supersonic windtunnel facility with Schlieren setup (top left), Schlieren image of 2 mm diameter jet injection in supersonic crossflow (top right) with structures in flow explained in schematic (bottom right). Measured (dimensionless) penetration depth for particular configuration compared with existing empirical formula)

MULTIPHASE FLOW EFFECTS IN COMPACT PRODUCED-WATER TREATMENT EQUIPMENT

PROJECT AIM

The physical phenomena occurring during produced-water treatment are studied numerically. Oil droplet, and gas bubble trajectories will be predicted employing Lagrangian particle tracking for both swirling flow and settling conditions. Influence of effects such as a history term are required for prediction of trajectories. Collision and coalescence are important factors for advanced compact produced-water treatment. Occurrence of such effects is predicted making use of droplet and bubble trajectories.

PROGRESS

A Lagrangian particle tracking method has been developed for generic flow fields. Both implicit Crank-Nicolson, and explicit fourth order Runge-Kutta schemes have been implemented. History force has been identified as force that needs to be investigated. A new expression for the history kernel has been obtained using experimental data from literature to improve existing Reynolds dependent kernel. Efficient collision detection has been implemented in particle tracking code. Two Lattice Boltzmann Methods for liquids have been developed, one using a BGK approach with a body force pressure correction, the other using a BBGKY approach, to investigate the history force in detail. Both explicit and implicit schemes have been implemented. 2-D flow about a cylinder has been investigated to explore the method, and the method has been extended to 3-D flow about a sphere.

DISSERTATIONS

-

SCIENTIFIC PUBLICATIONS

-

PROJECTLEADERS

HWM Hoeijmakers

RESEARCHTHEME

Mathematical and computational methods for fluid flow analysis

PARTICIPANTS

DF van Eijkeren, HWM Hoeijmakers

COOPERATIONS

FMC Technologies – Separation Systems, FACE (SINTEF)

FUNDED

FMC Technologies – Separation Systems, FACE (SINTEF)

University	-
FOM	-
STW	-
NWO Other	-
Industry	100 %
TNO	-
GTI	-
EU	-
Scholarships	-

START OF THE PROJECT

2009

INFORMATION

DF van Eijkeren

053 489 2482

d.f.vaneijkeren@utwente.nl

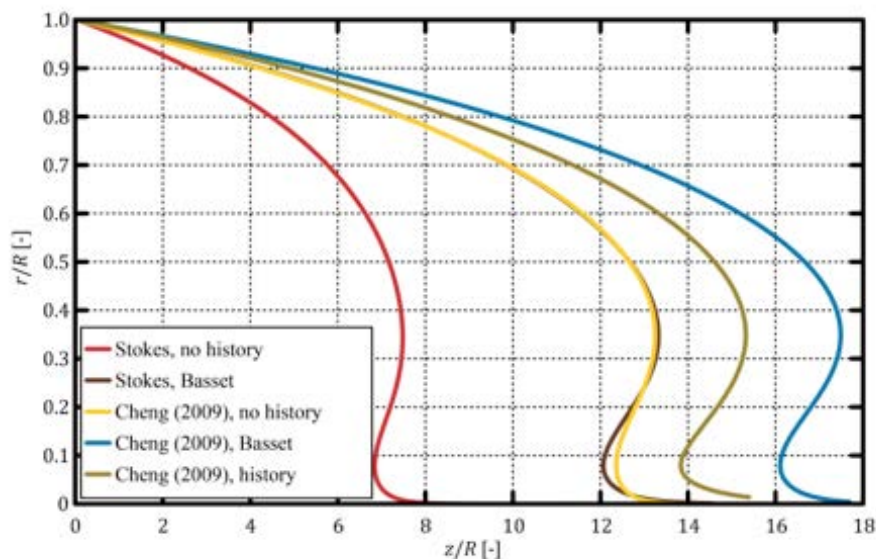

THIN LAYER FLOW

PROJECT LEADERS

CH Venner

RESEARCH THEME

Mathematical and computational methods for fluid flow analysis

PARTICIPANTS

CH Venner, HWM Hoeijmakers, SH Boffy, PM Lugt (SKF), J Snoeijer (PoF, UT), J Wang (Qingdao), AA Lubrecht (INSA).

COOPERATIONS

Physics of Fluids, UT/TN
INSA-de Lyon, France
Technical University of Brno, Czechia
Qingdao Technological University, PR. China
SKF ERC, Netherlands

FUNDED

University	50 %
FOM	-
STW	-
NWO Other	-
Industry	50 %
TNO	-
GTI	-
EU	-
Scholarships	-

START OF THE PROJECT

2007

INFORMATION

CH Venner
053 489 2488
c.h.venner@utwente.nl

PROJECT AIM

Development of accurate thin film/layer flow models and numerical simulation algorithms for the prediction of lubricant film formation capacity and lubrication life in rolling element bearing contacts in relation to operating conditions, lubricant rheology (oil-grease), supply conditions (starved-flooded), and material properties.

PROGRESS

Fundamental aspects and self-similarity in EHL contacts under squeeze conditions were studied and explained, and aspects of cam-follower systems. New optimally efficient multigrid algorithms were developed for interface design (lubricated and dry) and contact mechanics for heterogeneous materials allowing the use of many millions of unknowns and thus very accurate local material topology representation. First steps were taken towards computational diagnostics relating material science tomography data and stress computations. In addition effects of spray deposition, thin protective polymer layers, and specific aspects of grease rheology (water content, structure) on contact film behaviour have been studied.

DISSERTATIONS

-

SCIENTIFIC PUBLICATIONS

1. Boffy, H., Venner, C.H., Multigrid numerical simulation of contact mechanics of elastic materials with 3D heterogeneous subsurface topology. 2015, Tribology International, 92, 233-245.

Material model of ceramic with ellipsoidal needle inclusion. granular structure with interstitial glue (top left). Computed contact stresses (top right). Von Mises stress in material in central plane illustrating the low stress interstitial regions and the stress concentrations around the needle. . Computation using Multigrid algorithm solving 3D elasticity with about one billion unknowns.

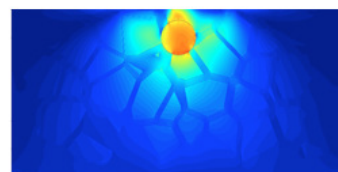
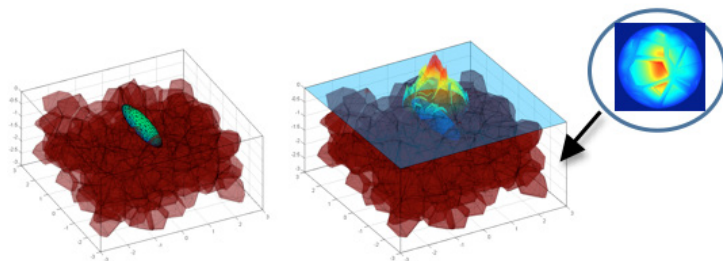

MULTISCALE ISLANDS MIXED LUBRICATION MODELING

PROJECT AIM

Development of a mixed lubrication model based on physical first principles representing relevant aspects on different scales to predict the behaviour of concentrated contacts as appearing between rolling elements and raceways in rolling element bearings under extreme operating conditions of very limited lubricant supply.

PROGRESS

Following detailed analysis of the flow around the contact new modeling approaches have been developed. A non-dimensional relation for cavitation bubble length in relation to operating conditions has been found. Current cavitation algorithms used in numerical simulations have shown to grossly underpredict the actual bubble length occurring in experiment. Incorporation of surface tension effects appears to be indispensable and is ongoing. Thin oedometric layer modeling of contacts aimed at mixed lubrication modeling nears completion and models are integrated in publications and in a thesis.

DISSERTATIONS

-

SCIENTIFIC PUBLICATIONS

-

PROJECT LEADERS

CH Venner

RESEARCH THEME

Mathematical and computational methods for fluid flow analysis

PARTICIPANTS

E van Emden, GE Morales-Espejel

COOPERATIONS

SKF

FUNDED

SKF

University -

FOM -

STW -

NWO Other -

Industry 100 %

TNO -

GTI -

EU -

Scholarships -

START OF THE PROJECT

2009

INFORMATION

CH Venner

053 489 2488

c.h.venner@utwente.nl

Cavitation bubble in the wake of an EHL contact for three different loads (top left), dimensionless bubble length measured and predicted as a function relevant dimensionless numbers, and, very long cavitation bubble configuration which can not be predicted with current generation theoretical models (right)

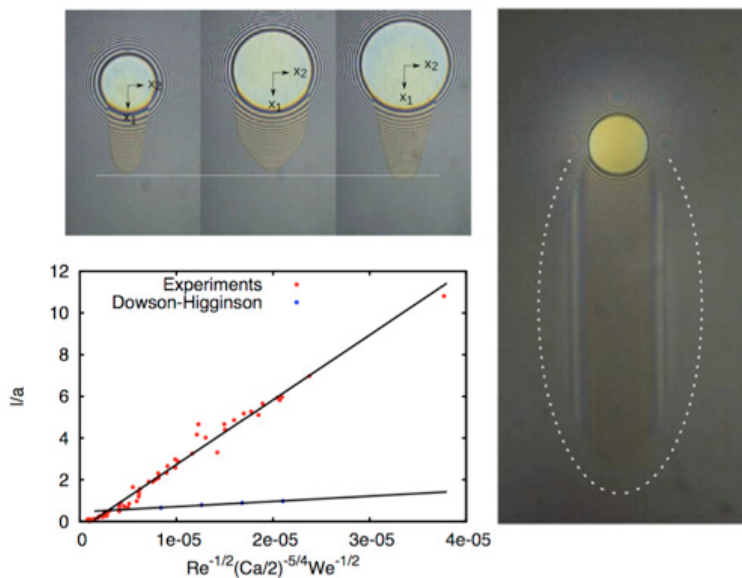

DEVELOPMENT OF ACOUSTIC PRESSURE AND PARTICLE VELOCITY TEST EQUIPMENT

PROJECT LEADERS

YH Wijnant, CH Venner

RESEARCH THEME

Complex dynamics of fluids

PARTICIPANTS

Olti Pjetri

COOPERATIONS

AAC Technologies (China)

FUNDED

University	-
FOM	-
STW	-
NWO Other	-
Industry	100 %
TNO	-
GTI	-
EU	-
Scholarships	-

START OF THE PROJECT

2015

INFORMATION

YH Wijnant
053 489 3635
y.h.wijnant@utwente.nl

PROJECT AIM

In very small loudspeakers (as used in hearing aids and mobile phones), small vents (holes) are used to equalize the static pressure inside the speaker to ambient. These small holes however might lead to a non-linear acoustic response of the speaker if not designed well. Aim of the project is to model and measure the pressure and air velocities close to these vents to assess these non-linearities.

PROGRESS

A finite element acoustic model has been made and a test setup designed. A prototype measurement device has been constructed.

DISSERTATIONS

-

SCIENTIFIC PUBLICATIONS

-

Small loudspeaker with 'vents' causing non-linear acoustic behavior

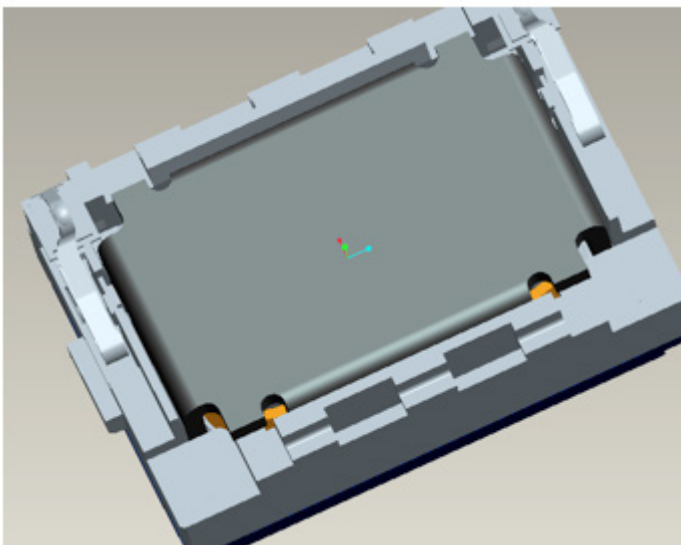

SEMI-ANALYTICAL METHODOLOGIES FOR AIRFOIL NOISE PREDICTION

PROJECT AIM

The noise generated aerodynamically by airfoil-shaped parts is a major issue in applications of large societal interest, such as office and home appliances, wind power generation, air and ground transportation vehicles, etc. At early design stages, semi-analytical noise prediction methodologies are preferred over more CPU-intensive methods, and have recently gained considerable accuracy through advanced physical modeling. This project aims to push further the accuracy and reliability of state-of-the-art semi-analytical techniques for the prediction of incoming-turbulence airfoil noise.

PROGRESS

This project continues Dr. de Santana work carried out at VKI during his PhD. When the acoustic wavelength is larger than the airfoil chord, i.e. the airfoil is acoustically compact, an extension to the Amiet theory is used, involving two extra applications of the Schwarzschild theorem to improve the convergence and are shown to significantly improve agreement with experimental results. To address geometrical effects, a technique was developed which applies the Boundary Element Methodology (BEM) for the linearized flow equations. This procedure is verified against analytical results, given by the Amiet technique for a flat-plate geometry, and applied to noise computations of generic geometry airfoils. Results shows that the airfoil shape impacts the acoustic prediction. Current research is directed at novel applications including fans and propeller configurations at different scales and experimental validation in the EFD aeroacoustic windtunnel.

DISSERTATIONS

1. Leandro Dantas de Santana, Semi-analytical methodologies for airfoil noise prediction, KULeuven, September 2015.

SCIENTIFIC PUBLICATIONS

1. Leandro D. Santana, Christophe Schram, Wim Desmet, "Airfoil noise prediction from 2D3C PIV data", AIAA/CEAS Aeroacoustics Workshop 2015.

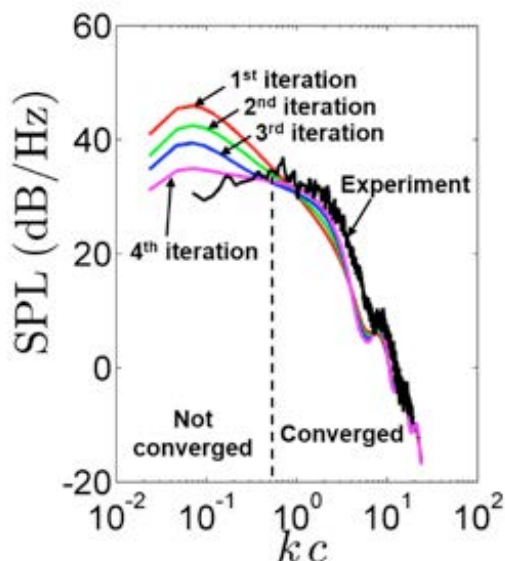

PROJECTLEADERS

L Dantas de Santana, CH Venner

RESEARCHTHEME

Complex dynamics of fluids

PARTICIPANTS

CH Venner, NP Kruyt, YH Wijnant

COOPERATIONS

VKI until sept 2015

FUNDED

EU until sept 2015 at VKI

University Twente since nov 2015

University 100 %

FOM -

STW -

NWO Other -

Industry -

TNO -

GTI -

EU -

Scholarships -

START OF THE PROJECT

2015

INFORMATION

L Dantas de Santana

053 489 2587

leandro.desantana@utwente.nl

[https://www.utwente.nl/ctw/ts/](https://www.utwente.nl/ctw/ts/organisation/scientific_staff/)

[organisation/scientific_staff/](https://www.utwente.nl/ctw/ts/organisation/scientific_staff/)

[Leandro%20de%20Santana/](https://www.utwente.nl/ctw/ts/organisation/scientific_staff/)

FLUID DYNAMICS OF NATURE-INSPIRED CONFIGURATIONS

PROJECT LEADERS

CH Venner, HWM Hoeijmakers

RESEARCH THEME

Complex dynamics of fluids

PARTICIPANTS

CH Venner, HWM Hoeijmakers

COOPERATIONS

-

FUNDED

UT

University 100 %

FOM -

STW -

NWO Other -

Industry -

TNO -

GTI -

EU -

Scholarships -

START OF THE PROJECT

2012

INFORMATION

HWM Hoeijmakers

053 489 4838

h.w.m.hoeijmakers@utwente.nl

PROJECT AIM

Investigate experimentally and numerically the flow about nature-inspired configurations, such as Robot Birds. These nature-inspired copies of real birds combine lift and propulsion by flapping wings. In the project (scale-models of) these, and others, configurations are investigated in the wind tunnel and numerically.

PROGRESS

Wind-tunnel experiments have been carried out for a flexible model of the wing of the peregrine bird carrying out a flapping motion similar to the true motion. From the velocity distribution measured in the wake employing a wake rake, it is shown that the time-averaged streamwise velocity distribution shows a jet-like pattern. This corresponds to results obtained from numerical simulations (for 2D sections at three spanwise stations) for this wing. These results of numerical simulation have correlated the jet-like pattern with the inverted von Karman vortex street. Such a flow field configuration is associated with a specific phase difference between the heave and pitch motion of the wing. The flow field has been visualised employing smoke released subsequently from a number of locations with postprocessing to combine the smoke traces in a time-accurate single flow picture.

DISSERTATIONS

-

SCIENTIFIC PUBLICATIONS

-



THERMAL ENGINEERING



Prof.dr.ir. ThH van der Meer



Prof.dr.ir. G Brem

The research activities of the Thermal Engineering Group mainly concentrate on thermal conversion processes for industrial and domestic applications from the disciplines thermodynamics, transport phenomena and fluid mechanics. The research aims at increasing use of renewable energy, and a more efficient and clean utilization of fossil fuels. The projects are organized around the themes turbulent combustion and thermo-acoustics and instationary heat transfer.

The research theme Turbulent Combustion and Thermo-acoustics is related to issues on ignition, extinction, flame stability, pollutant formation, combustion noise and its interaction with the combustion chamber structure. Numerical models are developed (within CFX), and experimental research is done like flow visualization, acoustic measurements, laser induced fluorescence and Raman/Rayleigh spectroscopy for in-flame measurements of temperature and species concentrations. Applications are: gas turbines, boilers and furnaces.

The research theme Instationary Heat Transfer is related to heat transfer in piston compressors, heat transfer and chemical conversion in pulsed compression reactors and new materials for enhanced heat transfer in regenerators and heat exchangers. Applications are: thermo-acoustic heat pumps and engines and magneto-caloric heat pumps and coolers. Numerical models are developed for the multi-physics phenomena in these systems supported by experimental research.

THE SOUND SOLUTION FOR SMALL SCALE RESIDENTIAL ENERGY CONVERSION

PROJECT AIM

As efficient usage of resources becomes more and more important because of their finiteness, one way to efficiently use energy is micro combined heat and power generation (micro-CHP). Therefore, Stirling engines raised interest for the domestic use of micro-CHP in recent years. Despite the promise of high efficiency due to the underlying Stirling cycle, these engines often have reliability problems because of their numerous moving parts. The engine under investigation makes use of a thermodynamic cycle similar to Stirling, but with less moving parts, therefore having a much higher reliability. Thus, we focus on the optimization of a thermoacoustic engine for application within a micro-CHP appliance.

PROGRESS

The research on jet pumps for thermoacoustic applications has led to a characterization of the different flow regimes in laminar oscillatory flows and their influence on the jet pump performance in terms of time-averaged pressure drop and acoustic power dissipation. A geometric parameter study is carried out and flow separation inside the jet pump is identified as the main source of performance loss. A separate study further focuses on characterizing and reducing flow separation in jet pumps. A design adjustment is developed that postpones the onset of flow separation and greatly enhances the jet pump performance, which is verified experimentally. Recently, the performance of jet pumps with multiple orifices is quantified and the interaction of vortex rings from adjacent orifices is studied using high-speed flow visualization (Fig. 1).

DISSERTATIONS

1. Bühler, S. (2015). Towards numerical simulation of components of thermoacoustic devices with commercial CFD software University of Twente.

SCIENTIFIC PUBLICATIONS

1. Oosterhuis, J. P., Bühler, S., Wilcox, D., and Van der Meer, T. H. (2015). "Jet pumps for thermoacoustic applications: design guidelines based on a numerical parameter study," *J. Acoust. Soc. Am.*, 138, 1991–2002. doi:10.1121/1.4929937.
2. Oosterhuis, J. P., Bühler, S., Wilcox, D., and Van der Meer, T. H. (2015). "A numerical investigation on the vortex formation and flow separation of the oscillatory flow in jet pumps," *J. Acoust. Soc. Am.*, 137, 1722–1731. doi:10.1121/1.4916279.
3. Bühler, S., Wilcox, D., Oosterhuis, J. P., and Van der Meer, T. H. (2015). "Mean temperature profile at the entrance of a thermoacoustic stacked screen heat exchanger," *Magnetohydrodynamics*, 51, 609–616.
4. Oosterhuis, J. P., Bühler, S., Wilcox, D. A., and Van der Meer, T. H. (2015). "Performance measurements of jet pumps with multiple holes," In 3rd International Workshop on Thermoacoustics, University of Twente, Enschede, The Netherlands, doi:10.3990/2.294.
5. Timmer, M. A. G., Oosterhuis, J. P., Bühler, S., Wilcox, D. A., and Van der Meer, T. H. (2015). "Reducing flow separation in jet pumps," In 3rd International Workshop on Thermoacoustics, University of Twente, Enschede, The Netherlands, doi:10.3990/2.296.
6. Vidya, M. C., Oosterhuis, J. P., and Van der Meer, T. H. (2015). "A traveling wave termination for a thermoacoustic setup," In 3rd International Workshop on Thermoacoustics, University of Twente, Enschede, The Netherlands, doi:10.3990/2.285.

PROJECTLEADERS

ThH van der Meer

RESEARCHTHEME

Complex dynamics of fluids

PARTICIPANTS

S Bühler, JP Oosterhuis

COOPERATIONS

-

FUNDED

Agentschap NL, Bosch

Thermotechnology

University 10 %

FOM -

STW -

NWO Other -

Industry 40 %

TNO -

GTI -

EU 50 %

Scholarships -

START OF THE PROJECT

2011

INFORMATION

ThH van der Meer

053 489 2562

t.h.vandermeer@utwente.nl

www.utwente.nl/ctw/thw

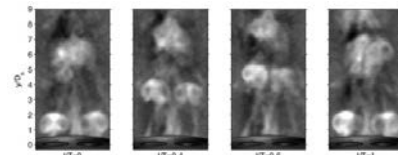

Visualization of vortex rings propagating from a jet pump with two adjacent holes and merging further downstream.

COMBUSTION MODELING OF COMPLEX 3D HEAT EXCHANGER GEOMETRIES AND SYSTEMATIC DESIGN OPTIMIZATION

PROJECT LEADERS

ThH van der Meer

RESEARCH THEME

Mathematical and computational methods for fluid flow analysis

PARTICIPANTS

Mahening Citra Vidya

COOPERATIONS

Bosch Thermotechnology

FUNDED

Bosch Thermotechnology

University -

FOM -

STW -

NWO Other -

Industry 100 %

TNO -

GTI -

EU -

Scholarships -

START OF THE PROJECT

2014

INFORMATION

Mahening Citra Vidya

06 29921458

m.c.vidya@utwente.nl

PROJECT AIM

This project aims to investigate a combustion model that can be used to estimate emission values (CO, NO_x) in complex 3D geometries. This model will be implemented to improve the current pin-fin heat exchanger in a domestic boiler by a systematic optimization with the adjoint method. The combustion model will then be developed so that not only the emission characteristics but also performance factors are optimized.

PROGRESS

Two-dimensional and three-dimensional direct numerical simulations of flow around a circular cylinder have been performed. These simulations have been validated with numerical and experimental results from literature. The characteristics of the transitional flow are defined and compared with other transitional flows at other Reynolds numbers. Properties such as velocity profile at the center plane of the three-dimensional simulation were obtained and compared with literature. Moreover, different flow structures were found from both simulations which suggest that the two-dimensional simulation could not fully capture the phenomena in a transitional flow.

The results of these simulations will become the starting point for further development using the adjoint method in OpenFoam.

DISSERTATIONS

-

SCIENTIFIC PUBLICATIONS

-

COPA-GT (COUPLED PARALLEL SIMULATION OF GAS TURBINES) SPRAY COMBUSTION

PROJECT AIM

The numerical simulation of the entire engine with all physics involved is a key element for scientific progress and innovation. Developing numerical tools and methodologies to simulate the entire gas turbine with multiple physical effects is a new challenge and the overall scientific objective of the COPA-GT project. In this task of the project numerical models are developed for spray evolution, evaporation, mixing and turbulent combustion. Targeted is transient behaviour of spray combustion and coupling to acoustics. The models are optimized for large scale parallel computation with embedding in full engine models.

PROGRESS

Numerical simulations were performed with ANSYS on an acoustically forced spray flame. The forcing leads to a considerable speed up of the combustion rate, but the driving mechanisms are different at low and high frequencies. A further investigation has been done to study the influence of the walls on the forced spray flame. Two parallel studies are carried out to understand the physics behind the evaporation in a reacting environment, and the turbulent combustion; RANS simulations were run to assess the influence of the boundary conditions on the velocity and mass flux field, and the validation of an in-house combustion model is performed. The implementation of this lookup-table model in Ansys, and its usage for non-premixed cases, is investigated, for steady and compressible flows.

DISSERTATIONS

-

SCIENTIFIC PUBLICATIONS

1. Fratalocchi, V. Kok, J.B.W., Numerical investigation of a non-confined spray flame exposed to acoustic forcing. ASME Turbo Expo 2015, June 15-19, Montreal Canada.

PROJECTLEADERS

JBW Kok

RESEARCHTHEME

Mathematical and computational methods for fluid flow analysis

PARTICIPANTS

V Fratalocchi, JBW Kok

COOPERATIONS

CERFACS, RWTH Aachen University, Von Karman Institute, Loughborough University, Turbomeca, Siemens, Barcelona Supercomputing Center, Jülich computational center, Bull, Ansys.

FUNDED

European Union Marie Curie ITN University -
FOM -
STW -
NWO Other -
Industry -
TNO -
GTI -
EU 100 %
Scholarships -

START OF THE PROJECT

2012

INFORMATION

JBW Kok
053 489 2582
j.b.w.kok@utwente.nl
www.thw.ctw.utwente.nl/

COPA-GT (COUPLED PARALLEL SIMULATION OF GAS TURBINES)

PROJECT LEADERS

JBW Kok

RESEARCH THEME

Mathematical and computational methods for fluid flow analysis

PARTICIPANTS

S Gövert, JBW Kok

COOPERATIONS

CERFACS, RWTH Aachen University, Von Karman Institute, Loughborough University, Turbomeca, Siemens, Barcelona Supercomputing Center, Jülich computational center, Bull, Ansys.

FUNDED

European Union Marie Curie ITN University	-
FOM	-
STW	-
NWO Other	-
Industry	-
TNO	-
GTI	-
EU	100 %
Scholarships	-

START OF THE PROJECT

2012

INFORMATION

JBW Kok
053 489 2582
j.b.w.kok@utwente.nl

PROJECT AIM

Until now, gas turbines have been designed following individual pathways for each component and each physical phenomenon. Nevertheless, the behavior of the individual components can be very different from their behavior when mounted together in an engine. To overcome this disadvantage, the numerical simulation of the entire engine with all physics involved is a key element for scientific progress and innovation. Developing numerical tools and methodologies to simulate the entire gas turbine with all physical effects is a new challenge and the overall scientific objective of the COPA-GT project.

PROGRESS

In the project European wide 13 PhD students and 5 Post Docs work under coordination of CERFACS in Toulouse. At the UT 3 PhD students are active. The project task of S. Gövert focuses on modelling fluid structure interaction (FSI) in gas turbine combustors as embedded in full engine computations. In the first year, FSI simulations of the Limousine combustor have been performed using the ANSYS simulation environment. Due to limitations in customization and parallelization, the ALYA multiphysics code (developed at the Barcelona Supercomputing Center) has been chosen as an alternative tool. An advancement of the CFI combustion model has been implemented and validated for a premixed jet flame and a swirl combustor. In depth heat transfer analysis of the jet flame is performed by the use of coupled CHT simulations. The model extension to non-premixed configurations is under development.

DISSERTATIONS

-

SCIENTIFIC PUBLICATIONS

1. S. Gövert, D. Mira, J.B.W. Kok, M. Vazquez, G. Houzeaux, 2015, Turbulent combustion modelling of a confined premixed jet flame including heat loss effects using tabulated chemistry, *Applied Energy*, Volume 156, 804-815.
2. S. Gövert, D. Mira, J.B.W. Kok, M. Vazquez, G. Houzeaux, Turbulent Combustion Modelling of a Confined Premixed Methane/Air Jet Flame Using Tabulated Chemistry, *Energy Procedia*, Volume 66, 2015, Pages 313-316.

UTILIZATION OF BIDIRECTIONAL TURBINES IN THERMOACOUSTIC ENGINES

PROJECT AIM

This project focuses on the conversion of acoustic power into electric power in thermoacoustic engines. For this purpose, a linear alternator is the most commonly used device. In this work, the use of a bidirectional turbine will be studied as an alternative for the acoustic to electric conversion. A bidirectional turbine rotates in the same direction, independent of the flow direction, and is therefore well suited for converting the oscillatory flow into rotational work and subsequently into electricity. The project aims to identify the operating characteristics (such as efficiency and power output) of the bidirectional turbine and optimize its application in thermoacoustic devices.

PROGRESS

At the start of this project a literature study has been done to investigate the different possibilities of converting acoustic power into electricity. Four types of devices have been identified: electrodynamic devices (e.g. linear alternators), piezoelectric devices, magnetohydrodynamic devices and bidirectional turbines. It is found that the most commonly used conversion technique is the linear alternator, but that the bidirectional turbines might be a better candidate in terms of complexity, manufacturing costs and scalability. To investigate the implementation and performance of a bidirectional turbine in thermoacoustic engines, a CFD model is currently being developed. Furthermore, several prototypes of bidirectional turbines will be 3D printed and experimentally tested in a resonator tube that is connected to a loudspeaker.

DISSERTATIONS

-

SCIENTIFIC PUBLICATIONS

-

PROJECTLEADERS

ThH van der Meer

RESEARCHTHEME

Complex dynamics of fluids

PARTICIPANTS

MAG Timmer

COOPERATIONS

-

FUNDED

NWO	
University	-
FOM	-
STW	-
NWO Other	100 %
Industry	-
TNO	-
GTI	-
EU	-
Scholarships	-

START OF THE PROJECT

2015

INFORMATION

MAG Timmer
053 489 5409
m.a.g.timmer@utwente.nl

PROJECT LEADERS

ThH van der Meer

RESEARCH THEME

Complex dynamics of fluids

PARTICIPANTS

TJ Taha, ThH van der Meer

COOPERATIONS

ECN

FUNDED

EL&I

University -

FOM -

STW -

NWO Other -

Industry 100 %

TNO -

GTI -

EU -

Scholarships -

START OF THE PROJECT

2010

INFORMATION

TJ Taha

053 489 2559

t.j.taha@ctw.utwente.nl

PROJECT AIM

The aim of the project is to study in depth the effect of carbon nano-fibers deposited on heat transfer surface for heat transfer to/ from a fluid. At first materials will be synthesized in a very controlled manner by growing carbon nano-fibers with in situ measurements of the weight increase and the heat of reaction of the synthesis process. Heat transfer to/from the new materials will be determined experimentally. Structural and morphological effect of the CNFs on heat transfer will be studied and optimal configuration will be derived. A production facility for the synthesis of carbon nano-fibers will be designed and built.

PROGRESS

Synthesis of vertically aligned CNTs was obtained by depositing 10nm Ta + 5nm Fe on silicon chip with integrated thin film 180nm Pt heat on 10nm Ta adhesive layer. A number of different samples with different morphological and topological surfaces were tested. Two setup orientations are chosen to measure the structural influence of the VACNFs on heat transfer performance. (1) Micro-channel heat transfer measurement setup was designed and produced to measure the structural influence of CNTs on silicon chip. Heat transfer and pressure drop measurements were made to quantify the influence of the nanostructures deposits on overall heat transfer performance enhancement. (2) Impinging jet flow setup was designed and built. Heat transfer performance characterization was made on different sample configuration (fully covered, inline and staggered arrangements).

DISSERTATIONS

1. Taha T.J., 2015, Carbon nanostructured surfaces for enhanced heat transport, thesis, <http://dx.doi.org/10.3990/1.9789036539456>.

SCIENTIFIC PUBLICATIONS

1. T.J. Taha, L. Lefferts and T.H. van der Meer, (2015), "Indirect Involvement of Amorphous Carbon Layer on Convective Heat Transfer Enhancement Using Carbon Nanofibers," *Journal of Heat Transfer*, 137(9), pp. 091007-091007, 10.1115/1.4030218.
2. T.J. Taha, L. Lefferts and T.H. van der Meer, (2015), "Influence of microscale surface modification on impinging flow heat transfer performance", *Journal of Heat Transfer*, doi:10.1115/1.4032311.
3. T.J. Taha and T.H. van der Meer, (2015), "Effects of surface modification using carbon nanotubes on fluid flow and heat transfer performance in micro-channel heat sink", *Proceedings of the 1st Thermal and Fluid Engineering Summer Conference, TFESC August 9-12, 2015, New York City, USA.*



MULTI SCALE MECHANICS (MSM)



Prof.dr.rer.nat. S Luding

The Multi Scale Mechanics group (MSM) is part of the department TFE (Thermal and Fluids Engineering) in the Faculty of Engineering Technology at the University of Twente, as well as member of the research institute MESA+. The group studies the static and dynamic properties of dry and wet granular materials, as well as fluids and solids in general.

Examples include segregation versus mixing; sticky powders; wave-propagation in disordered media; solid concrete; avalanche flows of grains, snow or soil; composite and self-healing materials. A wide range of length and time scales characterizes the relevant physical processes in these systems. At the microscopic level, the deformation behavior of the granule/atom/molecule with contact/interaction physics on the nano-meter scale determines the dynamics and statics of the particles. The mesoscopic level sees the collective motions of the individual granules involving e.g. shear localization and wave-propagation. Finally, on the macroscopic level, a granular material behaves as a fluid with complex flow behavior involving anisotropy. At each length scale, the question arises how the mechanics at that level is determined by the properties of the underlying level, and how, in turn, the current level affects the previous and the next levels.

Theory and experiments, supported by advanced numerical simulations, are aimed at understanding the various, multiple scales/levels and their intricate couplings. Micro-Macro theory is one way to predict and describe this hierarchy. By combining numerical simulations with theory and experiments, the Multi Scale Mechanics group is developing a comprehensive understanding of the properties of granular materials, fluids and solids. The group is also interested in mesoscale simulations (on intermediate level) of particles with attractive interactions, to study aggregation of self-assembly of patchy colloidal particles and proteins on the macromolecular scale, or to model asphalt on the stone-bitumen scale. Mesoscopic models use the small-scale information to formulate effective contact laws and allow thus to simulate much larger systems than possible with (too) detailed micro-models.

Besides improving our fundamental understanding of fluids and solids, the results find applications in the improvement of industrial processing procedures for granular matter, as well as contributing to the design of advanced materials, processes and equipment.

SIMULATING SEMI-SOLID RECHARGEABLE FLOW BATTERIES

PROJECT AIM

With the increasing number of non-dispatchable sustainable energy sources, electrical energy storage is crucial to maintaining a stable power-grid. The recently proposed 'semi-solid rechargeable flow battery' offers a promising new technique for such energy storage. The aim of this PhD project is to develop a simulation model for the complex physical processes taking place in the (dis)charge cell, in particular i) the flow behavior of sticky colloidal suspensions, ii) the flow of charge between the colloidal aggregates and the walls of the cell, and iii) the interplay between both flows.

PROGRESS

A recently developed rotational Brownian dynamics code has been implemented to model the aggregation of sticky spherical colloids. The aggregates move by translational and rotational Brownian dynamics, based on intra-cluster hydrodynamics, and coalesce upon contact. This model has been used to study the growth kinetics and fractal structure of the aggregates formed, revealing for the first time the influence of rotational Brownian motion on the aggregation process. An extension to rod-shaped particles, which are reported to have better battery performance, is in preparation.

DISSERTATIONS

-

SCIENTIFIC PUBLICATIONS

1. I.M. Ilie, W.K. den Otter and W.J. Briels, An elementary singularity-free Rotational Brownian Dynamics algorithm for anisotropic particles, *J. Chem. Phys.* 142, 114103 (2015).

PROJECTLEADERS

WK den Otter, S Luding

RESEARCHTHEME

Complex dynamics of fluids

PARTICIPANTS

D Palanisamy

COOPERATIONS

-

FUNDED

FOM, Shell CSER project

University -

FOM 50 %

STW -

NWO Other -

Industry 50 %

TNO -

GTI -

EU -

Scholarships -

START OF THE PROJECT

2014

INFORMATION

D Palanisamy

d.palanisamy@utwente.nl

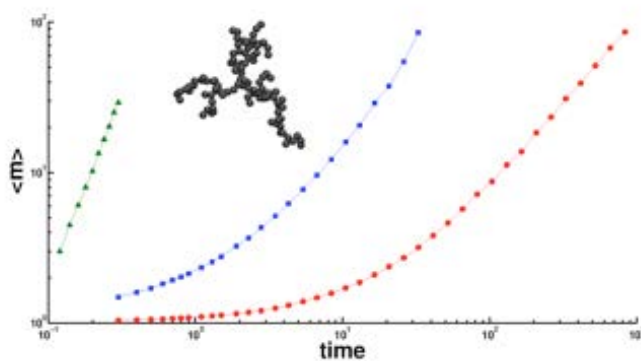

Mean cluster size of aggregates as a function of time, at three concentrations. Also shown is a typical aggregate

SHAPING SEGREGATION: ADVANCED MODELLING OF SEGREGATION AND ITS APPLICATION TO INDUSTRIAL PROCESSES

PROJECT LEADERS

AR Thornton

RESEARCH THEME

Mathematical and computational methods for fluid flow analysis

PARTICIPANTS

IFC Denissen

COOPERATIONS

-

FUNDED

STW-NWO VIDI

University -

FOM -

STW 100 %

NWO Other -

Industry -

TNO -

GTI -

EU -

Scholarships -

START OF THE PROJECT

2015

INFORMATION

IFC Denissen

053 489 8997

i.f.c.denissen@utwente.nl

PROJECT AIM

The aim of this project is to develop numerical tools to simulate polydisperse granular flows, as chute flows, and specifically for rotating geometries such as rotating drums. The continuum simulations will be done with the discontinuous Galerkin finite element method, which can be easily implemented in the UT in-house package hpGEM. The calibration of the continuum model will be done with a discrete particle method, so that a fast and accurate numerical solver can be developed.

PROGRESS

Models for shallow mono- and bi-dispersed granular flows down a chute have been discretized using a discontinuous Galerkin finite element method and also implemented in hpGEM. The simulations have been verified against some known solutions of these models, for example the 2D mono-dispersed flow through a contraction and the formation of a "bulbous head" in the 1D bi-dispersed flow. We see good agreement between the numerical simulations and known solutions of the model for all test cases, which indicates that the numerical simulations are an effective tool to study granular chute flows.

DISSERTATIONS

-

SCIENTIFIC PUBLICATIONS

-

height profile for a granular chute flow at super-critical speed through a contraction

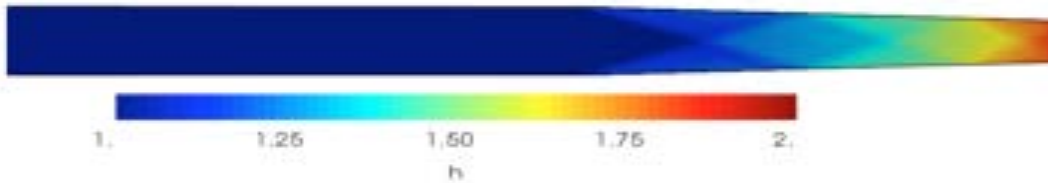

height profile for a granular chute flow at sub-critical speed through a contraction

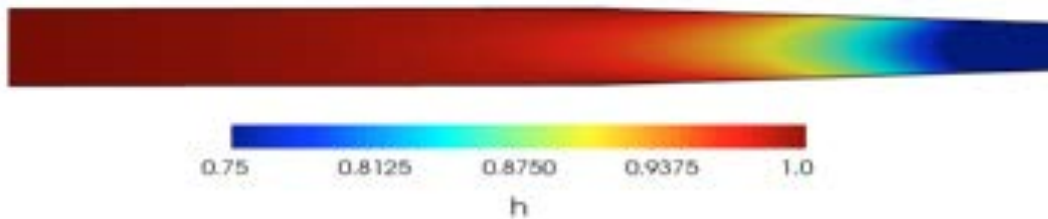

same as figure 1, but as a 3D rendering and from a different angle.

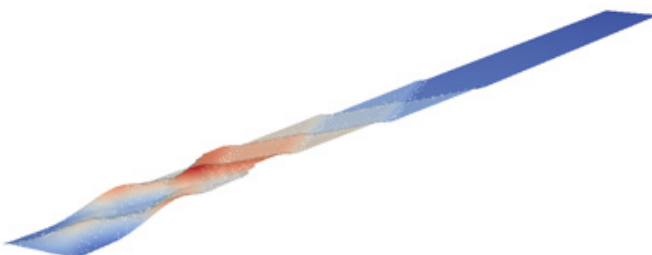

**COMPUTATIONAL SCIENCE FOR GAS/OIL EXPLORATION,
PRODUCTION AND PROCESSING**

PROJECT AIM

Characterization of the connection between the structure of dry granular media and the signal transmission behavior; understanding the role of contact and micro-structure details on the bulk behavior is important for a general understanding of the physics of such systems. Propagation of stress and energy in granular systems is sensitive to even small amounts of disorder in either mass or the contact network. We numerically and analytically study the effects of isolated mass-disorder and anisotropy on the energy transfer and frequency content of signals propagated in these systems.

PROGRESS

Wave propagation simulations through 3 dimensional disordered polydisperse packings of frictional spheres showed that structural anisotropy leads to frequency filtering effects; Energy contained in the uniaxial translational motion (P-wave) is quickly scattered to shear and rotational modes. To isolate the P-wave from shear and rotational modes and to study the effect of mass disorder (quantified by ξ) on energy transmission and frequency propagation, a mass disordered granular chain has been used. The evolution of standing waves were studied across these chains. When the chain is homogeneous, the total energy of the individual granules is constant but in a mass disordered chain, energy propagates in the form of scattering as well as localization is observed around the elements with low mass. Spectral study shows that low mass elements can oscillate throughout k-space with fixed discrete frequencies much higher than the cut-off frequency set due to discretization of the medium.

DISSERTATIONS

-

SCIENTIFIC PUBLICATIONS

-

PROJECTLEADERS

S Luding

RESEARCHTHEME

Complex dynamics of fluids

PARTICIPANTS

R K Shrivastava, V Magnanimo

COOPERATIONS

-

FUNDED

FOM-SHELL Computational Science

University -

FOM 50 %

STW -

NWO Other -

Industry 50 %

TNO -

GTI -

EU -

Scholarships -

START OF THE PROJECT

2014

INFORMATION

S Luding

s.luding@utwente.nl

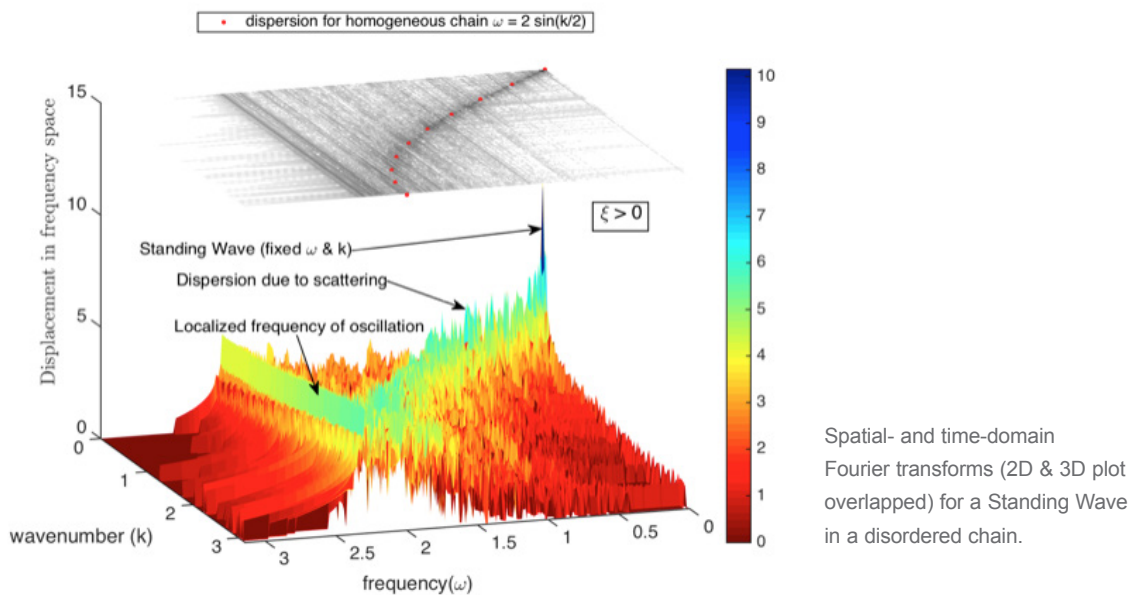

MODELING AND SIMULATING FLUID-PARTICLE MIXTURES

PROJECT LEADERS

S Luding, A Thornton

RESEARCH THEME

Complex dynamics of fluids

PARTICIPANTS

MP van Schrojenstein Lantman

COOPERATIONS

-

FUNDED

STW-NWO VIDI

University -

FOM -

STW -

NWO Other 100 %

Industry -

TNO -

GTI -

EU -

Scholarships -

START OF THE PROJECT

2014

INFORMATION

MP van Schrojenstein Lantman

053 489 3345

m.p.vanschrojensteinlantman@
utwente.nl

PROJECT AIM

The goal of this project is to develop open-source software capable of simulating particles in a fluid and modeling of multiple scales: with full-resolved and under-resolved (mesoscale) fluid. For meso scale simulations, two existing open-source software packages both developed at the University of Twente, that is, MercuryDPM and hpGEM, could be coupled. For small scales, a simple potential flow model will be developed and implemented as an extension to MercuryDPM. The developed software can be applied to various applications, including rotating drums or the dispersion of a powder bed by a liquid jet.

PROGRESS

Based on a thorough literature study, a method of coupling fluid and particles was chosen. The full-resolved fluid-particle model can be introduced in the Discontinuous Galerkin package hpGEM by using the fictitious distributed Lagrange multiplier method, enabling fast numerical solution. Another major advantage is that it can relatively easily be extended to non-spherical particles.

A side project on coupling particles with Stokes flow is making progress. The project exploits a combination of an analytical solution with the fast multipole method, ensuring a quick algorithm.

DISSERTATIONS

-

SCIENTIFIC PUBLICATIONS

-

BRIDGING THE GAP BETWEEN PARTICULATE SYSTEMS AND CONTINUUM THEORY

PROJECT AIM

Quasi-static deformations of soft particles and granular materials, have been widely investigated because of their significant importance in industry and science. However, many challenges of describing their macroscopic behaviors still remain. At the microscopic scale, mechanical responses of soft particles are probed as a reconstruction of force-chain networks, where complicated non-affine displacements of particles cause the "recombination" of force-chains. The PDFs in soft particles have practical importance, but only the master equation with the transition rate allows to predict the macroscopic material response based on a mesoscale stochastic theory basis.

PROGRESS

We study the microscopic response of force-chain networks in jammed soft particles to quasi-static isotropic (de)compressions by molecular dynamics simulations. We show that not only contacts but also interparticle gaps between the nearest neighbors must be considered for the stochastic evolution of the PDFs of forces, where the mutual exchange of contacts and interparticle gaps, i.e. opening and closing contacts, are also crucial to the incremental system behavior. By numerically determining the transition rates for all changes of contacts and gaps, we formulate a Master equation for the PDFs of forces, where the insight one gets from the transition rates is striking: The mean change of forces reflects non-affine system response, while their fluctuations obey uncorrelated Gaussian statistics. In contrast, interparticle gaps are reacting mostly affine in average, but imply multi-scale correlations according to a much wider stable distribution function.

DISSERTATIONS

-

SCIENTIFIC PUBLICATIONS

1. Kuniyasu Saitoh and Hideyuki Mizuno. "Anomalous energy cascades in dense granular materials yielding under simple shear deformations" *Soft Matter* 12 (2016) 1360.
2. Kuniyasu Saitoh, Satoshi Takada, and Hisao Hayakawa. "Hydrodynamic instabilities in shear flows of cohesive granular particles" *Soft Matter* 11 (2015) 6371. On the inside front cover.
3. Kuniyasu Saitoh, Vanessa Magnanimo, and Stefan Luding. "A Master equation for the probability distribution functions of forces in soft particle packings" *Soft Matter* 11 (2015) 1253. On the inside front cover.
4. Abhinendra Singh, Vanessa Magnanimo, Kuniyasu Saitoh, and Stefan Luding "The role of gravity or pressure and contact stiffness in granular rheology" *New J. Phys.* 17 (2015) 043028.

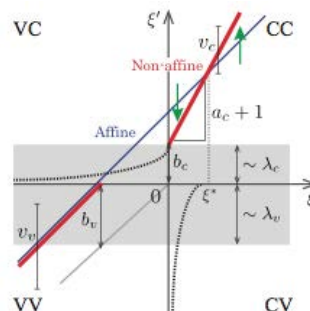

PROJECT LEADERS

S Luding

RESEARCH THEME

Mathematical and computational methods for fluid flow analysis

PARTICIPANTS

K Saitoh

COOPERATIONS

M. Sperl (DLR Cologne)
Satoshi Takada, and Hisao Hayakawa, and Hideyuki Mizuno (Japan)

FUNDED

VICI-STW VICI	
University	-
FOM	-
STW	-
NWO Other	100 %
Industry	-
TNO	-
GTI	-
EU	-
Scholarships	-

START OF THE PROJECT

2011

INFORMATION

K Saitoh
053 489 5363
k.saitoh@utwente.nl
www2.msm.ctw.utwente.nl/saitohk

A schematic picture of the difference between affine and non-affine responses of scaled overlaps to compression, where the blue and red solid lines represent ξ_{affine} (for small and large particles) and linear functions, $m(\xi)$, respectively. In CC, ξ_{affine} and $m(\xi)$ intersect at $\xi = \xi_0$, where the green arrows represent the decrease and increase of scaled overlaps during relaxation. The excess slope in CC, a_c , and all the dimensionless lengths, b_l , v_l , and λ_l , are proportional to γ , where λ_c and λ_v represent typical penetration lengths of new contacts and new virtual contacts, respectively

BRIDGING THE GAP BETWEEN PARTICULATE SYSTEMS AND CONTINUUM THEORY

PROJECT LEADERS

S Luding

RESEARCH THEME

Mathematical and computational methods for fluid flow analysis

PARTICIPANTS

D Vescovi

COOPERATIONS

-

FUNDED

VICI-STW VICI

University -

FOM -

STW -

NWO Other 100 %

Industry -

TNO -

GTI -

EU -

Scholarships -

START OF THE PROJECT

2015

INFORMATION

D Vescovi

053 489 6452

d.vescovi@utwente.nl

<https://www.utwente.nl/ctw/msm/>

People/Members/Dalila%20Vescovi.

html

PROJECT AIM

Granular materials exhibit solid-like behavior if the particles are densely packed and a network of persistent contacts develops within the medium, resulting in a jammed structure. On the other hand, when the grains are largely spaced and free to move in any direction, interacting only through collisions, the medium is unjammed and behaves like a fluid. As a consequence, a key question concerns how to model the jamming transition from fluid to solid-like behavior and vice-versa. The first step in this direction is the prediction of the correct scaling laws that relate stresses, shear rate and density in the whole range of flow regimes.

PROGRESS

This work focuses on the simple shear flow of an ideal granular material, composed of identical, frictionless spheres, under steady conditions. A series of Discrete Element Method simulations are performed in order to investigate the role of particle stiffness at different volume fractions, below and above jamming. The particle stiffness is strictly related to finite contact duration and persistent deformations of particles, and, as a consequence, plays an important role on the rheology of granular systems and, in particular, on the solid-fluid transition. First, we analyze our numerical results to derive appropriate scaling laws in both unjammed and jammed states, far from the transition. Then, we use the scaling laws inferred in these regimes to propose phenomenological constitutive relations for the stresses. In particular, the two regimes are merged in a unique function which is (i) continuous and differentiable at any point and (ii) able to predict the behavior even in the intermediate regime.

DISSERTATIONS

-

SCIENTIFIC PUBLICATIONS

-

Sketch of the constant-volume simple shear flow configuration. A homogeneous granular material composed of frictionless, soft spheres is sheared in horizontal direction, at constant shear rate, by using Lees-Edwards periodic boundary conditions in the vertical direction.

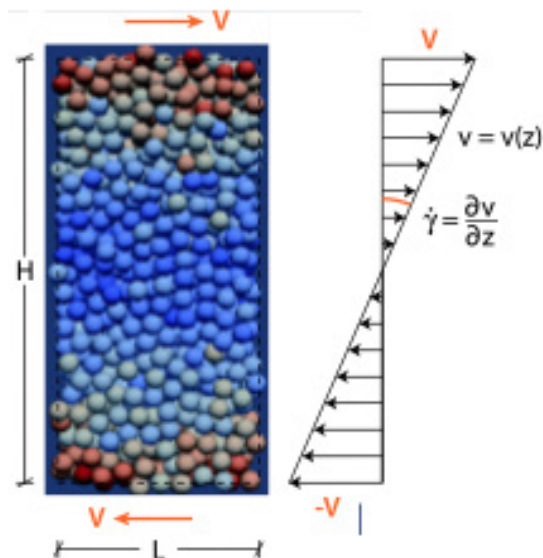

BRIDGING THE GAP BETWEEN PARTICULATE SYSTEMS AND CONTINUUM THEORY

PROJECT AIM

We apply and compare microscopic and macroscopic numerical and theoretical models for flowing granular matter. Models are applied to a driven granular system, consisting of a vertically shaken narrow box filled with grains. The studied system presents many different inhomogeneous stable states as a function of the energy injection and grain properties. We focus on the transitions between the different states and study the influence of finite particle size and low number of particles, which may lead to a better general understanding of the out-of-equilibrium statistical physics behind agitated granular systems.

PROGRESS

The project was finished, with a successful doctoral thesis and defense. A second experimental verification of low-frequency oscillations—a collective semi-periodic movement discovered in the shallow vibrated geometry—is currently under way with the Physics of Fluids group of the University of Twente. In collaboration with S. Rhebergen we have continued to investigate the hydrodynamic solutions of the density inverted state, obtaining excellent agreement of the macroscopic fields in the quasi-one-dimensional column geometry for high energy injections. This has allowed us to understand better the relevance of each physical process in the transition to convective states. Work on the study of finite-size and finite-number effects on granular systems yielded new general insights into the role of fluctuations in granular flows, and is ready for submission early 2016.

DISSERTATIONS

1. N. Rivas, Feb. 2015, UTwente, NL. From discrete to continuum models of shaken granular matter.

SCIENTIFIC PUBLICATIONS

1. From the granular Leidenfrost state to buoyancy-driven convection. Nicolas Rivas, Anthony R Thornton, Stefan Luding, Devaraj van der Meer. Physical Review E 91 (4), 042202.
2. Fourth Conference on Particle-Based Methods (PARTICLES 2015), Barcelona, Spain (Invited talk).

PROJECT LEADERS

S Luding

RESEARCH THEME

Complex dynamics of fluids

PARTICIPANTS

A Thornton, D van der Meer

COOPERATIONS

D. Parker and K. Windows-Yule,
University of Birmingham
S. Rhebergen, University of Oxford

FUNDED

NWO-STW VICI	
University	-
FOM	-
STW	100 %
NWO Other	-
Industry	-
TNO	-
GTI	-
EU	-
Scholarships	-

START OF THE PROJECT

2011

INFORMATION

N Rivas
+49 (0)15773672631
n.rivas@fz-juelich.de
<http://science.nicolasrivas.com>

JAMMING, SHEAR BANDING AND MICROSTRUCTURES

PROJECT LEADERS

S Luding

RESEARCH THEME

Complex dynamics of fluids

PARTICIPANTS

A Singh, V Magnanimo, K Saitoh

COOPERATIONS

-

FUNDED

NWO

University -

FOM -

STW -

NWO Other 100 %

Industry -

TNO -

GTI -

EU -

Scholarships -

START OF THE PROJECT

2009

INFORMATION

A Singh

053 489 2694

A.Singh@ctw.utwente.nl

PROJECT AIM

Goal is to probe the connections between jamming, shear banding and microstructure in numerical simulations of Brownian and non-Brownian systems with various interaction forces. Particle simulations are used to study the shear banding in a 'split bottom ring shear cell', where a slow quasi-static deformation leads to wide shear bands being formed away from the side-walls that allow for a local averaging procedure to obtain all information about density, strain, stress, and structure.

PROGRESS

Discrete element simulations are used to study the steady-state shear rheology of dense weakly frictional granular assembly both for slow-quasistatic and inertial flows. The effect of local pressure and contact stiffness was the focus of this study. While traditionally the inertial number, i.e., the ratio of stress to strain-rate time scales, is used to describe the flow rheology, we report that a second dimensionless number, the ratio of stress and softness time scales, must also be included to characterize the bulk flow behavior. For slow- quasi static flows, the shear-resistance of the material was found to decrease with increase of either particle softness or external compression stress. This trend was traced back to the anisotropy of the contact network, displaying a linear correlation between the effective friction coefficient and the deviatoric fabric in the steady state. This interesting correlation is further extended to the faster, inertial flows.

DISSERTATIONS

SCIENTIFIC PUBLICATIONS

1. A. Singh, V. Magnanimo, K. Saitoh, and S. Luding, The role of gravity or pressure and contact stiffness in granular rheology, *New Journal of Physics* 17, 043028, 2015.
2. S. Roy, A. Singh, S. Luding, and T. Weinhart, Micro-macro transition and simplified contact models for wet granular materials, *Computational Particle Mechanics*, pp. 1-14, (10.1007/s40571-015-0061-8), 07 August 2015.

The global shear resistance plotted against (left) gravity g , and (right) the global compressibility (as defined in [1]), on a log-linear scale for different values of the normal stiffness as shown in the legend. The solid line represents Eq. (14) in [1].

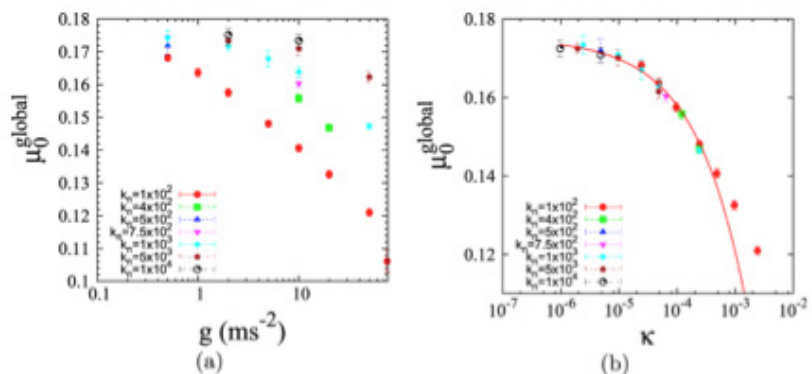

SHAPING SEGREGATION: ADVANCE MODELLING OF SEGREGATION AND ITS APPLICATION TO INDUSTRIAL PROCESSES

PROJECT AIM

To develop a unified continuum model for predicting particle segregation – using state-of-the-art experimental techniques and particle simulations – which is capable of simulating realistic particles and complex system geometries. The model will also be able to handle polydisperse flows of irregularly shaped particles with evolving size-distributions.

PROGRESS

On the numerical front, a highly effective averaging technique called coarse graining was extended to bidisperse mixtures varying in both size and density. Given the particle information such as positions, velocities and forces acting on them, one can extract the macroscopic field variables like density, velocity and stresses. The fields are no approximations as they are constructed to locally satisfy the mass and momentum balance equations. By this micro-macro mapping, one can use discrete particle simulations or experiments to develop and calibrate novel, improved continuum models.

DISSERTATIONS

-

SCIENTIFIC PUBLICATIONS

1. Tunuguntla D. R., Thornton A. R. and Weinhart. T. From discrete data to continuum fields: an extension to bidisperse mixtures. *Journal of Computational Particle Mechanics*, 1-17. <http://dx.doi.org/10.1007/s40571-015-0087-y>.
2. Windows-Yule C. R. K., Tunuguntla D. R. and Parker D. J. Numerical modelling of granular flows: a reality check. *Journal of Computational Particle Mechanics*, 1-22. <http://dx.doi.org/10.1007/s40571-015-0083-2>.

PROJECT LEADERS

AR Thornton

RESEARCH THEME

Mathematical and computational methods for fluid flow analysis

PARTICIPANTS

DR Tunuguntla

COOPERATIONS

Dr. Thomas Weinhart (Uni. Twente), Prof. Stefan Luding (Uni. Twente), Prof. Devaraj van der Meer (Uni. Twente), Prof. Christophe Ancey (EPFL), Prof. Nico Gray (Uni. Manchester), Dr. Nathalie Vriend (Uni. Cambridge), Prof. Marco Ramaoli (Uni. Surrey), Friesland Campina B. V., BASF

FUNDED

STW	
University	-
FOM	-
STW	100 %
NWO Other	-
Industry	-
TNO	-
GTI	-
EU	-
Scholarships	-

START OF THE PROJECT

2015

INFORMATION

DR Tunuguntla
053 489 5696
D.R.Tunuguntla@utwente.nl

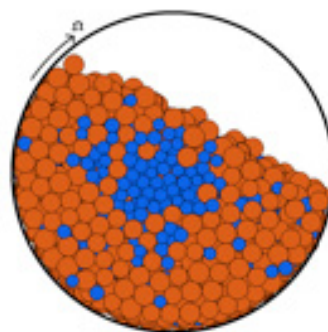
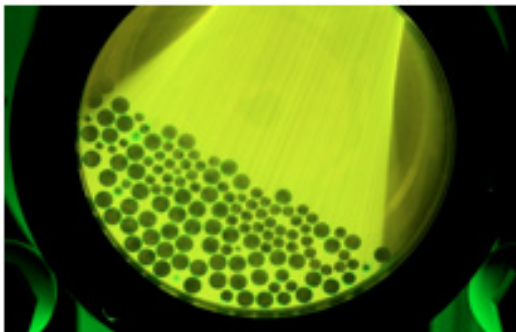

: Illustrates an exquisite application of Refractive Index Matching technique (left, experiment) and particle simulation (right, see mercurydpm.org) to understand the dynamics of a partially filled rotating drum.

HYDRODYNAMIC THEORY OF WET PARTICLE SYSTEMS: MODELING, SIMULATION AND VALIDATION BASED ON MICROSCOPIC AND MACROSCOPIC DESCRIPTIONS

PROJECT LEADERS

S Luding, T Weinhart

RESEARCH THEME

Mathematical and computational methods for granular material flow analysis

PARTICIPANTS

S Roy

COOPERATIONS

R Schwarze (TU Freiberg), S Turek (TU Dortmund), A Gladky (TU Freiberg), A Ouazzi (TU Dortmund), S Mandal (TU Dortmund)

FUNDED

STW (UTwente) and DFG (joint project with TU Dortmund and TU Freiberg)

University	-
FOM	-
STW	50 %
NWO Other	-
Industry	50 %
TNO	-
GTI	-
EU	-
Scholarships	-

START OF THE PROJECT

2013

INFORMATION

S Luding
053 489 4212
s.luding@utwente.nl

Snapshots of the 30 degree section (left: weak cohesion, right: strong cohesion) showing the angular velocities (color coded with blue as low velocity and green to orange as higher velocity) of 11000 particles confined between a stationary inner cylinder (black) and a concentric rotating outer cylinder (moving with part of the bottom, orange). The localized shear-band is indicated by green color for weak cohesion. Agglomeration of particles is observed for strong cohesion without formation of shear band.

PROJECT AIM

The objective of the project is to develop a description of the flow of partially wet granular materials, based on detailed knowledge of the links between micro-scale and macro-scale material parameters. The main aims of the project are the formulation of suitable constitutive equations for the stress-strain relations of wet granular materials, the calibration of the parameters in these constitutive equations with Discrete Element Method (DEM) simulations, the validation of the micro-macro transition with data from experiments on wet granular materials, and the development of more efficient macroscopic simulation tools to model large-scale experiments.

PROGRESS

The cylindrical split-bottom shear cell, see figure, has proven a convenient system to study the flow behavior of dry granular materials at the microscopic and macroscopic level. In the current project, the DEM simulations are extended with an appropriate liquid capillary bridge model between the particles. The micro-macro behavior of partially wet granular materials has been analyzed [1, 2] and a correlation is developed. We use a simplified contact model, which shows the same macroscopic behavior as the more complex liquid capillary bridge model. By comparing the two models, we show that the adhesion energy and the maximum adhesion force are the dominant microscopic control parameters. We also study the rheology of wet granular materials, obtaining the dependence of the effective friction coefficient on one dimensionless number at a time. The total effective friction coefficient turns out to be the product of these dependencies.

DISSERTATIONS

-

SCIENTIFIC PUBLICATIONS

1. S. Roy, S. Luding, and T. Weinhart, Macroscopic bulk cohesion and torque for wet granular materials. 8th International Conference for Conveying and Handling of Particulate Solids, 2015.
2. Roy, S., Singh A., Luding, S. and Weinhart, T. Micro-macro transition and simplified contact models for wet granular materials. Comput. Part. Mech. 2015 (10.1007/s40571-015-0061-8).
3. Roy, S., Luding, S. and Weinhart, T. Towards hydrodynamic simulation of wet particle systems. Procedia Eng. 102, 1531-38 (2015).

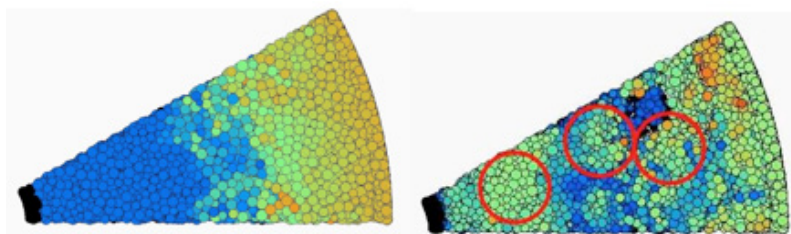

SINTERING – MODELING OF PRESSURE-, TEMPERATURE-, OR TIME-DEPENDENT CONTACTS

PROJECT AIM

The goal of this project is to model particles in contact, in particular for particles that melt and sinter when heated and thereby lose their identity. For this, temperature- and pressure-dependent contact models have to be developed in parallel to contact-measurements in the group of dr. Kappl (Mainz). The resulting many-particle simulation model will be experimentally validated against bulk experiments. The model will then be used for the micro-macro transition: based on the microscopic contact-mechanics and –physics between particles, deduce constitutive relations for the macroscopic description of sintered materials.

PROGRESS

Contact modeling and simulations of sintered material is in progress, in collaboration with M. Kappl and R Fuchs (MPI for Polymer Physics, Mainz), where sintering of micron-sized particles is studied using Atomic Force Microscopy. Modelling also includes cohesive materials.

Micro-macro transition methods as described above are implemented and extended in MercuryDPM; incorporating bidispersity and particle shape. MercuryDPM is an open-source code for particle simulations developed within the Multi Scale Mechanics group and is actively developed. It is a very versatile, easily understandable code, and thus enables the transition of scientific knowledge to users in industry and academia.

DISSERTATIONS

-

SCIENTIFIC PUBLICATIONS

1. D. R. Tunuguntla, A. R. Thornton, T. Weinhart, From discrete elements to continuum fields: Extension to bidisperse systems, *Comput. Part. Mech.*, <http://dx.doi.org/10.1007/s40571-015-0087-y>, (2015).
2. T. Weinhart, C. Labra, S. Luding, J. Ooi, Influence of coarse-graining parameters on the analysis of DEM simulations of silo flow, *Powder Tech.* 2015 <http://dx.doi.org/10.1016/j.powtec.2015.11.052> (2015).
3. S. Roy, A. Singh, S. Luding, T. Weinhart, Micro–macro transition and simplified contact models for wet granular materials, *Comput. Part. Mech.*, <http://dx.doi.org/10.1007/s40571-015-0061-8> (2015).

PROJECTLEADERS

S Luding

RESEARCHTHEME

Mathematical and computational methods for fluid flow analysis

PARTICIPANTS

T Weinhart

COOPERATIONS

M Kappl (MPIP Mainz), J Tomas (Uni Magdeburg), T Staedler (Uni Siegen)

FUNDED

DFG	
University	-
FOM	-
STW	-
NWO Other	-
Industry	100 %
TNO	-
GTI	-
EU	-
Scholarships	-

START OF THE PROJECT

2011

INFORMATION

S Luding
053 489 4212
s.luding@utwente.nl

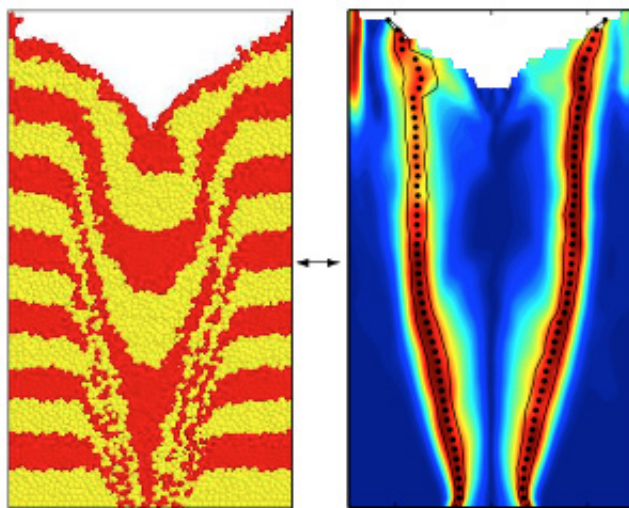

Visualisation of the three distinct flow regimes in a model silo flow:

- (i) a stagnant zone, (ii) a high shear localisation zone and (iii) a core zone with fast flow.

DETECTION AND GUIDANCE OF NANOPARTICLES FOR ENHANCED OIL RECOVERY

PROJECT LEADERS

S Luding, H Steeb, J Harting

RESEARCH THEME

Complex dynamics of fluids

PARTICIPANTS

I Guven

COOPERATIONS

Shell-FOM IPP

FUNDED

Shell-FOM IPP

University -

FOM -

STW -

NWO Other -

Industry 100 %

TNO -

GTI -

EU -

Scholarships -

START OF THE PROJECT

2010

INFORMATION

H Steeb

+49(0)234 32 23080

holger.steeb@rub.de

S Luding

053 489 4212

s.luding@utwente.nl

PROJECT AIM

The project aims to investigate the behavior of oil-water mixtures in porous media by means of combined electromagnetic-acoustic wave propagation. The emulsion will be stabilized by amphiphilic ferro-magnetic nano-particles. The goals are to establish whether these particles are a suitable alternative to current enhanced oil recovery techniques, and whether pulsed electromagnetic fields can be used to guide the particles to regions of interest.

PROGRESS

The focus in the fourth year of the project was the evaluation of the ultrasound experiments of sintered samples, which are saturated with magnetorheological fluids (MRF). MRFs are suspensions of magnetizable micron-sized particles, which change their apparent viscosity, when it is subjected to a magnetic field. The propagating acoustic wave through the MRF-saturated sample is studied at different magnetic strength. Figure 1 (left) shows exemplarily the coherent part of received time signals of a MRF-saturated sample with bead diameters between 1.0 and 1.2 mm at different magnetic strengths. Figure 1 (right) shows the corresponding amplitude spectra.

DISSERTATIONS

-

SCIENTIFIC PUBLICATIONS

1. Hydraulic properties of sintered glass bead systems, I. Gueven, S. Frijters, H. Steeb, S. Luding and J. Harting, Granular Matter, accepted, in press.
2. Hydraulic and acoustical properties of porous sintered glass bead systems, I. Gueven, PhD thesis (draft).

Received time signal (left) with corresponding power spectrum (right) of a MRF-saturated glass bead sample at different magnetic strengths B in Tesla

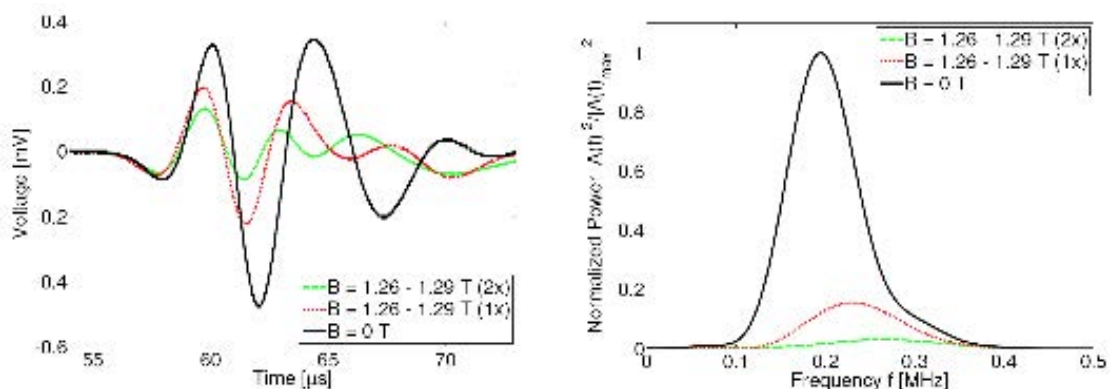

SHAPING SEGREGATION: ADVANCED MODELLING OF SEGREGATION AND ITS APPLICATION TO INDUSTRIAL PROCESSES

PROJECT AIM

To develop a unified model of particle size segregation that can accommodate evolving size distributions in complex geometries. The model will be developed and validated against a broad range of experimental and simulational results acquired from numerous, diverse system geometries.

PROGRESS

In the project so far we have experimentally investigated the effects of system geometry, particle geometry, the inclusion of interstitial fluids and the application of vibrational excitation on the behaviour of rotating granular systems. In doing so, we have demonstrated that the inclusion of an interstitial fluid can alter the effective gravity experienced by a system, and hence alter its flow regime and segregated state (see Fig. 1), and demonstrating the existence of new system states. We have also demonstrated various manners in which system geometry can be used to help predict and control the phase-separation of granular systems. We have additionally shown that the geometry of particles has a pronounced effect on the phase state and dynamics of a system, demonstrating striking parallels with colloidal and liquid-crystal systems.

DISSERTATIONS

-

SCIENTIFIC PUBLICATIONS

1. Windows-Yule, C.R.K., Rosato, A.D., Thornton, A.R. and Parker, D.J., 2015. Resonance effects on the dynamics of dense granular beds: achieving optimal energy transfer in vibrated granular systems. *New journal of physics*, 17(2), p.023015.
2. González, S., Windows-Yule, C.R.K., Luding, S., Parker, D.J. and Thornton, A.R., 2015. Forced axial segregation in axially inhomogeneous rotating systems. *Physical Review E*, 92(2), p.022202.
3. Windows-Yule, C.R.K., Douglas, G.J.M. and Parker, D.J., 2015. Competition between geometrically induced and density-driven segregation mechanisms in vibrofluidized granular systems. *Physical Review E*, 91(3), p.032205.
4. Windows-Yule, C.R.K., Rosato, A.D., Parker, D.J. and Thornton, A.R., 2015. Maximizing energy transfer in vibrofluidized granular systems. *Physical Review E*, 91(5), p.052203.
5. Windows-Yule, K. and Parker, D., 2015. Density-driven segregation in binary and ternary granular systems. *KONA Powder and Particle Journal*, 32, pp.163-175.
6. Rosato, A.D., Zuo, L., Blackmore, D., Wu, H., Hornthrop, D.J., Parker, D.J. and Windows-Yule, C., 2015. Tapped granular column dynamics: simulations, experiments and modeling. *Computational Particle Mechanics*, pp.1-16.
7. Windows-Yule, C.R.K., Tunuguntla, D.R. and Parker, D.J., 2015. Numerical modelling of granular flows: a reality check. *Computational Particle Mechanics*, pp.1-22.

PROJECT LEADERS

AR Thornton

RESEARCH THEME

Mathematical and computational methods for fluid flow analysis

PARTICIPANTS

CRK Windows-Yule

COOPERATIONS

Prof. D. J. Parker, (University of Birmingham), Prof. A. D. Rosato (New Jersey Institute of Technology) Dr. T. Leadbeater (University of Cape Town), Prof. S. Luding (University of Twente), Dr. W. K. den Otter (University of Twente)

FUNDED

STW-VIDI	
University	-
FOM	-
STW	100 %
NWO Other	-
Industry	-
TNO	-
GTI	-
EU	-
Scholarships	-

START OF THE PROJECT

2015

INFORMATION

CRK Windows-Yule
+44-7989472953
c.r.windows-yule@utwente.nl



Prof.dr. SJMH Hulscher

The work of the “Water Engineering and Management (WEM) group was originally mainly devoted to the modelling of sand waves on the seabed. First it was shown, that the seabed patterns in the North Sea can be explained as free instabilities of the seabed. Subsequently, the modelling of sand waves was extended and refined. The group has worked on a scientific and practical tool for fully nonlinear modelling of sand waves. Over the last five years, the offshore morphodynamic work has broadened to rivers, coasts and blue-ice. Alternate bars in a flume were compared with (Ginzburg-)Landau-type models. The group was the first to explore data assimilation for morphodynamic predictions. Further work concentrated on using data assimilation to combine field data with sand wave amplitude models for maintenance dredging management of navigation channels and sand wave-related pipeline problems. Also, North Sea data were analysed and a new bed mode, called long bedwaves, was discovered. The origin of nearshore bars was addressed. A method was developed for modelling human interferences in a morphodynamic setting. This has opened perspectives for a new approach towards modelling large-scale sand mining in shallow seas. A project for developing tools for evaluation of human interference in the North Sea for optimal management of the seabed started recently and sediment transport concerning near-shore sand pits is being investigated. Since 2000 the group has studied the use of morphodynamical models in a societal context. Recently, a method for decision making based on quantitative information including uncertainties was developed in the multidisciplinary project Flyland, which opens the field of designing an assessment framework for appropriate modelling.

SMARTSEA - SAFE NAVIGATION BY OPTIMIZING SEA BED MONITORING AND WATERWAY MAINTENANCE USING FUNDAMENTAL KNOWLEDGE OF SEA BED DYNAMICS

PROJECT AIM

We aim to devise an optimized policy of sea bed monitoring and waterway maintenance in shallow seas, based on knowledge of sea bed dynamics, in order to warrant both nautical safety and port access. To this end, we define three subprojects: P1 on the influence of storm events and wind waves on sand wave dynamics; P2 on the feedback among waterways, waterway maintenance (e.g., dredging) and the surrounding seabed environment; and P3 on how to translate/combine knowledge of marine systems into a national survey and maintenance policy for the Netherlands Continental Shelf and waterways?

PROGRESS

Subproject 1 (G.H.P. Campmans): An idealized sand wave model, based on linear stability analysis, has been developed that is able to qualitatively describe the effects of storm-related processes on sand wave dynamics. Currently, a journal paper is being written and two related MSc projects have started, 1) the influence of sand waves on wind waves and 2) a systematic analysis of the developed model.

Subproject 2 (J.M. Damen): A method for data analysis of static (i.e., instantaneous) sandwave properties has been completed, leading to a map of sandwave properties for the entire NCS. Currently, a method for the analysis of sand wave dynamics (e.g. migration and growth) is being developed. Also, an MSc-project on explaining variations of sand waves crests has been formulated.

DISSERTATIONS

-

SCIENTIFIC PUBLICATIONS

-

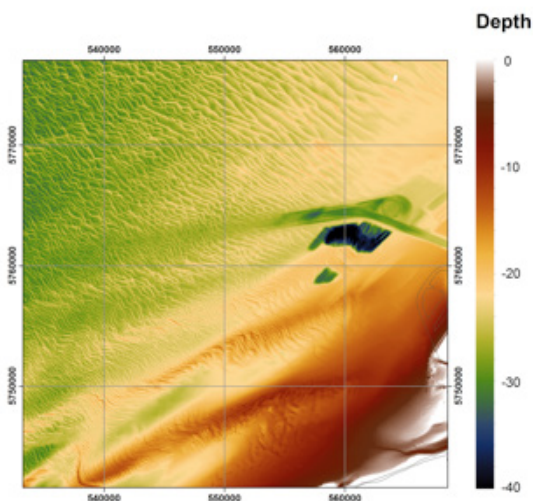

PROJECTLEADERS

PC Roos

RESEARCHTHEME

Mathematical and computational methods for fluid flow analysis

PARTICIPANTS

GHP Campmans, JM Damen, R Toodesh, TAGP van Dijk, PC Roos, AA Verhagen, SJMH Hulscher, RF Hanssen, HJ de Vriend, T Ligteringen, NA Kinneking

COOPERATIONS

Rijkswaterstaat, Netherlands Hydrographic Service
Advanced Consultancy Romke Bijker
Arcadis Nederland, MOW Vlaamse Hydrografie, Deltares, Delft University of Technology

FUNDED

STW (TKI Maritime Call)
Co-funders: Rijkswaterstaat, Netherlands Hydrographic Service, Deltares, Advanced Consultancy Romke Bijker (ACRB)
University -
FOM -
STW 63 %
NWO Other -
Industry 33 %
TNO -
GTI 4 %
EU -
Scholarships -

START OF THE PROJECT

2014

INFORMATION

PC Roos
053 489 5608
p.c.roos@utwente.nl

SAND EXTRACTION AND COASTAL SAFETY

PROJECT LEADERS

SJMH Hulscher

RESEARCH THEME

Complex dynamics of fluids

PARTICIPANTS

W Chen, PC Roos, HM Schuttelaars,
SJMH Hulscher

COOPERATIONS

Closely linked to Future Ems project
and TU Delft

FUNDED

University of Twente
CSC (China Scholarship Council)
scholarship
Future Ems project
University -
FOM -
STW -
NWO Other -
Industry -
TNO -
GTI -
EU -
Scholarships 100 %

START OF THE PROJECT

2011-PhD defense 12/2015

INFORMATION

PC Roos
053 489 5608
p.c.roos@utwente.nl
www.wem.ctw.utwente.nl

PROJECT AIM

The main objective of this project is to understand a scientific problem: how does 'basin-scale' sand extraction affect the set-up at the coast, both in the short term (immediately after extraction) and in the long term (through changes in morphology)? And solve a design problem: to warrant coastal safety, is it possible to shape the sand extractions required for nourishments and land reclamations such that potentially adverse effects of these interventions are minimized? Develop a three-dimensional hydro- and morphodynamic model that allowing for a quick and systematic analysis of residual circulation and set-up at the coast, accounting for the basin's morphodynamic evolution, the balance is between wind stress, atmospheric pressure gradient, density gradient, and river runoff. This model should (1) provide insight into the physical mechanisms, and (2) serve as a tool to analyze the impacts of various spatial extraction scenarios.

PROGRESS

In the year 2015, the project was finished, which involved the following steps. First, after the first study on resonance properties of flat bed basins was published, a second study into the influence of large-scale topographic elements on resonance properties was conducted (Chen et al., submitteda). Here, it should be noted that the direction of the project was geared more toward storm surge modelling than to sand extraction design (see project aim), a change that was agreed upon in the user group. Next, to gain further insight into the model's performance, it was applied to simulated the storm surge due to Hurricane Katrina in New Orleans coastal basin. This involved extending the atmospheric forcing of the model to cover the coupled wind-pressure field of the so-called Holland-B model. This study gives in insight in the influence of storm characteristics on the spatio-temporal storm surge patterns (Chen et al., submittedb). Finally, Chen's Ph.D. thesis was published (Chen 2015), which was successfully defended on 16 December 2015, at the University of Twente.

DISSERTATIONS

-

SCIENTIFIC PUBLICATIONS

1. Chen, W.L., P.C. Roos, H.M. Schuttelaars, S.J.M.H. Hulscher (2015) Resonance properties of a closed rotating rectangular basin subject to space- and time-dependent wind forcing, *Ocean Dyn.*, 65(3), 325-339, doi: 10.1007/s10236-015-0813-2.
2. Chen, W.L., P.C. Roos, H.M. Schuttelaars, M. Kumar, T.J. Zitman, S.J.M.H. Hulscher (submitteda) Response of large-scale coastal basins to wind forcing: influence of topography.
3. Chen, W.L., L. Straatsma, P.C. Roos, H.M. Schuttelaars, M. van Ledden, S.J.M.H. Hulscher (submittedb) The influence of storm characteristics on storm surges in New Orleans coastal basin.
4. Chen, W.L. (2015) Idealised modelling of storm surges in large-scale coastal basins, Ph.D thesis, University of Twente, The Netherlands, ISBN 978-90-365-4014-8, 130 pp.

AEOLIAN AND HYDRODYNAMIC SAND EXCHANGE ACROSS BEACHES

PROJECT AIM

The objective of this study is to understand and model the exchange of sand, between the nearshore zone and the dunes on a time scale of years to decades. As the accretionary part of the exchange is the least understood, an important part of this study will be to determine to what extent different characteristics of the intertidal beach influence the rates of aeolian sand transport. This project focuses on providing a better understanding of the extent to which the intertidal zone properly works as a sediment source for onshore aeolian transport. This zone is expected to be a crucial element in the relationship between dune development and the dynamics of nearshore bars in the long-term.

PROGRESS

New experiments have been developed during 2015, mainly in June, September and October at Texel, Zandmotor and Egmond aan Zee with aim to collect data on rates of aeolian sand transport using laser particle counter sensors and sandtraps. From these experiments we obtained some deviating results in the measurements by a co-located sand trap and Wenglor sensor array and because of this we designed a laboratory experiment with a high speed camera to further look into the detectability of various grain sizes by the Wenglor sensor. During this year a conference abstract have been submitted and accepted.

DISSERTATIONS

-

SCIENTIFIC PUBLICATIONS

1. Duarte Campos, L.A., Wijnberg, K.M., van der Weerd, A.J. and Bakker, G. (2015) "Recording aeolian sand transport using laser particle counters". Book of Abstracts NCK days 2015, 18-20 March 2015. Camperduin (pp. 61).

PROJECTLEADERS

SJMH Hulscher,
CM Dohmen-Janssen

RESEARCHTHEME

Complex dynamics of fluids

PARTICIPANTS

L Duarte Campos, KM Wijnberg,
SJMH Hulscher

COOPERATIONS

Closely linked to: NatureCoast
Project, CoCoChannel Project.

FUNDED

CONICYT Chile (National
Commission of Scientific and
Technological Research)
University -
FOM -
STW -
NWO Other -
Industry -
TNO -
GTI -
EU -
Scholarships 100 %

START OF THE PROJECT

2013

INFORMATION

L Duarte Campos
053 489 3711
l.a.duarte campos@utwente.nl
[http://www.utwente.nl/ctw/wem/
organisatie/medewerkers/duarte%20
campos/Leonardo_Duarte/](http://www.utwente.nl/ctw/wem/organisatie/medewerkers/duarte%20campos/Leonardo_Duarte/)

LINKING BUILDING-WITH-NATURE TYPE INTERVENTIONS IN CHANNEL-SHOAL SYSTEMS TO SUB-AERIAL IMPACTS ON THE BEACH-DUNE SYSTEM

PROJECT LEADERS

KM Wijnberg

RESEARCH THEME

Complex dynamics of fluids

PARTICIPANTS

FG Silva, SJMH Hulscher, AV de Groot, JPM Mulder

COOPERATIONS

IMARES, Deltares, UNESCO-IHE, Delft University of Technology, Arcadis, Rijkswaterstaat Waterdienst, Arens Bureau voor strand en duinonderzoek, Hoogheemraadschap Hollands Noorderkwartier

FUNDED

NWO, Hoogheemraadschap Hollands Noorderkwartier University	-
FOM	-
STW	-
NWO Other	92,3 %
Industry	-
TNO	-
GTI	-
EU	7,7 %
Scholarships	-

START OF THE PROJECT

2014

INFORMATION

FG Silva
053 489 1013
f.galifornisilva@utwente.nl
www.utwente.nl/ctw/wem/organisatie/medewerkers/wijnberg/kathelijne/index.html

PROJECT AIM

The aim of this project is to link Building-with-nature interventions in channel-shoal systems in tidal inlets to impacts in the adjacent beach-dune system, in a convenient time-scale for stakeholders. Therefore, it is necessary to understand which scenarios of beach-dune system response can be expected to occur under various shoreline development conditions and make the insights accessible to the stakeholder community.

PROGRESS

Relevant literature has been studied in order to situate the current study within the present knowledge. Furthermore, the research proposal was successfully defended. Data analysis related to the scope of the project was done in order to enhance the understanding of the beach-dune dynamics in systems close to inlets. Moreover, simulations with XBeach model were done to have insights regarding the effects of storm surges over dunes near inlets, and field surveys based on its results were planned. The next steps are related to data analysis and numerical modelling aiming at the understanding of the processes over the area. A paper is foreseen later in this year.

DISSERTATIONS

-

SCIENTIFIC PUBLICATIONS

-

RIVER BED FORM EVOLUTION MODELING FOR FLOOD MANAGEMENT

PROJECT AIM

- Subproject 1: Dune evolution and transition to plane beds (van Duin)
Subproject 2: The influence of suspended sediment transport on dune evolution (Naqshband)
Subproject 3: Application of bed form roughness in operational flood modelling (Warmink).

PROGRESS

The project was finished in December 2015. The main results are published in two PhD dissertations and other publications. The project provided and extensive flume dataset of transitions of subaqueous bed forms to upper stage plane bed (USPB). We found that the transport of suspended sand transport, in particular, is critical to the flattening out of river dunes. A model was developed to predict dune evolution, including transitions to USPB. The application of this model for the Dutch Rhine branches showed that hysteresis can be predicted, thereby reducing the need for calibration and increasing the accuracy in the extrapolation to extreme situations, such as the design water levels in the Netherlands. We further showed that transitions from the dune regime to USPB will probably not occur in all branches for design conditions in the Netherlands. But local transitions can occur, which might have a significant effect on water levels and river bed morphology. Further research will look into this.

DISSERTATIONS

1. Duin, Olav Jacob Maarten van (2015, December 17). Sediment transport processes in dune morphology and the transition to upper-stage plane bed. UT Universiteit Twente (133 pag.) (Enschede: Universiteit Twente). Prom./coprom.: prof.dr. S.J.M.H. Hulscher & dr.ir. J.S. Ribberink.
2. Naqshband, Suleyman (2014, December 18). Morphodynamics of river dunes: suspended sediment transport along mobile dunes and dune development towards upper stage plane bed. University of Twente (149 pag.) (Enschede: University of Twente). Prom./coprom.: prof.dr. S.J.M.H. Hulscher & dr.ir. J.S. Ribberink.

SCIENTIFIC PUBLICATIONS

1. Augustijn, D.C.M. and Warmink, J.J. (Eds.) Proceedings NCR-days 2014, Enschede, October 2-3.
2. Duin, O.J.M. van, Hulscher, S.J.M.H., Ribberink, J.S. & Dohmen-Janssen, C.M. (in press). Which bed load transport formulations allow modelling the transition from dunes to upper-stage plane beds. *Journal of hydraulic engineering*.
3. Hulscher, S.J.M.H., Schielen, R.M.J., Augustijn, D.C.M., Warmink, J.J., Van der Voort, M.C., Middelkoop, H., Kleinhans, M.G., Leuven, R.S.E.W., Lenders, H.J.R., Smits, A.J.M., Fliervoet, J.M., Uijttewaai, W.S.J., Blom, A., Wallinga, J., Hoitink, A.J.F., Buijsse, A.D., Geerling, G.W., Makaske, B. (2014). RiverCare, towards self-sustaining multifunctional rivers. In D.C.M. Augustijn & J.J. Warmink (Eds.), Proceedings NCR-days 2014, Enschede, October 2-3, pp 13-14.
4. Jellesma, M., Huthoff, F., Paarlberg, A.J., Warmink, J.J., Hulscher, S.J.M.H. & Lefebvre, J. (2015). Form drag of subaqueous dune configurations. In A. Mynett (Ed.), E-proceedings of the 36th IAHR World Congress, 28 June-3 July 2015, The Hague, The Netherlands (pp. 1-2). Madrid: IAHR.

PROJECTLEADERS

SJMH Hulscher,
CM Dohmen-Janssen

RESEARCHTHEME

Mathematical and computational methods for fluid flow analysis

PARTICIPANTS

OJM van Duin, S Naqshband,
JJ Warmink, JS Ribberink,
R Schielen, AJ Paalberg

COOPERATIONS

Deltares, HKV, Rijkswaterstaat,
Waterdienst, University of
Braunschweig

FUNDED

NWO/STW, University of Twente,
Deltares/RWS, HKV
University 45 %
FOM 50 %
STW -
NWO Other -
Industry 5 %
TNO -
GTI -
EU -
Scholarships -

START OF THE PROJECT

2010

INFORMATION

OJM van Duin
O.J.M.vanDuin@utwente.nl

S Naqshband
S.Naqshband@utwente.nl

J.J. Warmink
J.J.Warmink@utwente.nl

5. Naqshband, S., Duin, O.J.M. van, Ribberink, J.S. & Hulscher, S.J.M.H. (2015). Modeling river dune development and dune transition to upper stage plane bed, doi: 10.1002/esp.3789. *Earth surface processes and landforms*. 10.1002/esp.3789
6. Warmink, J.J. & Booij, M.J. (2015). Uncertainty analysis in river modelling, doi: 10.1007/978-3-319-17719-9_11. In P. Rowinski & A. Radecki-Pawlik (Eds.), *Rivers - Physical, fluvial and environmental processes* (pp. 255-277). Switzerland: Springer International Publishing. http://dx.doi.org/10.1007/978-3-319-17719-9_11
7. Warmink, J.J., Naqshband, S. & Duin, O.J.M. van (2015). Comparison of two bed form models to predict bed form roughness for flood modelling. In A. Mynett (Ed.), *E-proceedings of the 36th IAHR World Congress, 28 June-3 July 2015, The Hague, The Netherlands* (pp. 1-6). Madrid: IAHR.

THE EFFECT OF MEGA-NOURISHMENT PROJECTS ON SAND SUPPLY TO THE DUNES

PROJECT AIM

Recently, a mega-nourishment (21 Mm³ of sand) has been built at the Dutch coast. This is an innovative way of nourishing which is expected to protect the coast for approximately 20 years. The goal of this study is to describe and explain the impact of mega-nourishments on spatial and temporal variation in aeolian sediment supply (i.e. wind-driven) towards the upper beach and foredunes on a medium long time scale (e.g. 20 years). Currently, it is still unresolved how to estimate longer term and larger scale dune behavior, although this knowledge is essential for assessing coastal dune safety. The research is part of an "STW Perspectief Programma" NatureCoast.

PROGRESS

The project began in November 2015, since which an extensive literature review has been undertaken. Work has now begun on a research proposal to be submitted in May 2016.

DISSERTATIONS

-

SCIENTIFIC PUBLICATIONS

-

PROJECTLEADERS

KM Wijnberg

RESEARCHTHEME

Complex dynamics of fluids

PARTICIPANTS

I Williams, SJMH Hulscher

COOPERATIONS

Wageningen University, Delft University of Technology, Utrecht University, VU University of Amsterdam, NIOZ, Alterra, United States Geological Service (USGS), Deltares

FUNDED

STW	
University	-
FOM	-
STW	100 %
NWO Other	-
Industry	-
TNO	-
GTI	-
EU	-
Scholarships	-

START OF THE PROJECT

2015

INFORMATION

I Williams
053 489 2044
i.a.williams@utwente.nl

PROJECT LEADERS

SJMH Hulscher

RESEARCH THEME

Mathematical and computational methods for fluid flow analysis

PARTICIPANTS

JP Aguilar López, JJ Warmink, RMJ Schielen, Dohmen-Janssen, SJMH Hulscher, M Kok

COOPERATIONS

Deltares, HKV, Rijkswaterstaat, Waterdienst, Arcadis

FUNDED

STW-perspectief	
University	-
FOM	-
STW	100 %
NWO Other	-
Industry	-
TNO	-
GTI	-
EU	-
Scholarships	-

START OF THE PROJECT

2012

INFORMATION

J Pablo Aguilar
053 489 40 38
j.p.aguilarlopez@utwente.nl
<http://www.utwente.nl/ctw/wem/organisatie/medewerkers/aguilarlopez.doc/>

PROJECT AIM

Flood risk safety philosophy is changing more and more in the direction of a system probability of failure approach, which should replace the current overload per dike section approach. The project aims to:

1. Estimate the main failure mechanisms considering their possible correlations.
2. Derive set of limit state equations based in other common variables.
3. Emulate the failure mechanisms from model.
4. Implement the methodology in the current safety assessment.

PROGRESS

For the case of wave overtopping, the change in bed slope and surface roughness increase the exerted shear stresses once a wave is located over a dike during a storm. The actual methods underestimate the effect of turbulence in the scouring processes. Hence a CFD RAND K-EPSILON model was built in order to study the effects of such discontinuities. This model is calibrated based on the wave overtopping simulator and the results show that dikes with roads located on the crest can accelerate the scouring process when compared to the case of a dike with the crest covered with grass.

DISSERTATIONS

-

SCIENTIFIC PUBLICATIONS

1. Surrogate modeling for failure probability estimation of multifunctional flood defences (Paper accepted) -IAHR2015 World Congress - Den Haag-Netherlands, Aguilar López, J. P., Warmink, J. J., Schielen, R. M. J., and Hulscher, S. J. M. H. (2015).
2. Correlation effect in probabilistic design against piping in multi-functional flood defences (Full paper) -ISGSR2015 – Proceedings of International Symposium in Geotechnical safety and Risk, Rotterdam-Netherlands ,Aguilar López, J. P., Warmink, J. J., Schielen, R. M. J., and Hulscher, S. J. M. H. (2015).
3. Soil stochastic parameter correlation impact on the piping erosion failure. Journal of structural safety (Paper accepted for publication) Aguilar López, J. P., Warmink, J. J., Schielen, R. M. J., and Hulscher, S. J. M. H. (2015).
4. Piping erosion safety assessment of flood defences founded over sewer pipes. (Paper submitted) Aguilar López, J. P., Warmink, J. J., Schielen, R. M. J., and Hulscher, S. J. M. H. (2015) – submitted to European Journal of Environmental and Civil Engineering.

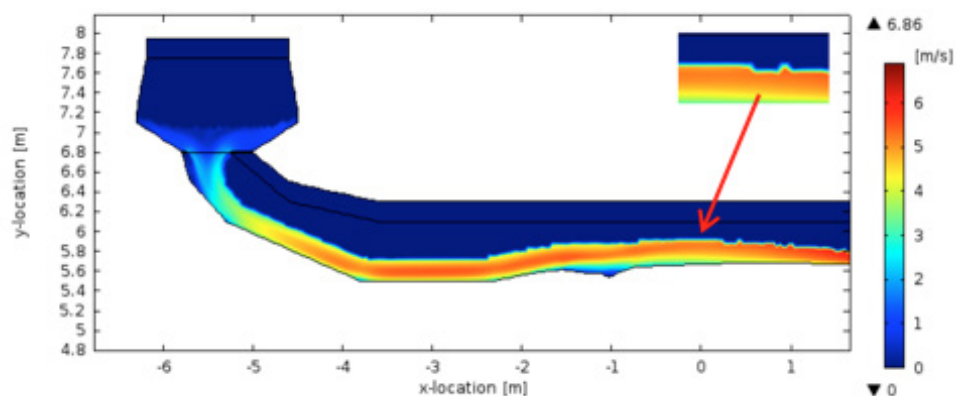

SAND TRANSPORT UNDER IRREGULAR AND BREAKING WAVE CONDITIONS

PROJECT AIM

The research has two main aims: (1) to improve understanding of the near-bed hydrodynamics and sand transport processes occurring under real-scale irregular non-breaking and regular breaking wave conditions and (2) to develop a new practical model for predicting sand transport under waves, accounting for wave irregularity and wave breaking in a way that is well founded on experimental data and understanding of the fundamental processes. The research is based on a combination of fixed and mobile-bed laboratory experiments (incl. PhD-project J. van der Zanden) and process-based numerical modeling (incl. post-doc A. Fernández Mora).

PROGRESS

Data treatment of mobile-bed hydrodynamic and sediment process measurements under large breaking waves is in an advanced stage. Two MSc projects related to the project finished; the first on hydrodynamics (data treatment), the second on morphodynamic modeling (using the recently collected data as validation). As a side-step, a paper on sheet flow measurements in the swash zone (funded by EU through HydraLab IV-WISE) was accepted for publication in Coastal Engineering. Further progress is made on improving the process-based morphodynamic model. In particular, the model code is adapted in order to make it better applicable to wave bottom boundary layer flow. Preliminary results show good agreement between the process-based model and the wave flume data in terms of hydrodynamics (wave dynamics and velocities).

DISSERTATIONS

-

SCIENTIFIC PUBLICATIONS

1. van der Zanden, J., J. M. Alsina, I. Cáceres, R. H. Buijsrogge and J. S. Ribberink (2015). Bed level motions and sheet flow processes in the swash zone: Observations with a new conductivity-based concentration measuring technique (CCM+). Coastal Engineering 105: 47-65. doi: 10.1016/j.coastaleng.2015.08.009.
2. van der Werf, J. J., R. Veen, J. S. Ribberink and J. van der Zanden (2015). Testing of the new SANTOSS transport formula in the Delft3D morphological modeling system. Proceedings of Coastal Sediments. San Diego, USA: 14 pp.
3. Van der Zanden, J., D. A. Van der A, J. S. Ribberink, T. O'Donoghue, D. Hurther, I. Caceres and P. D. Thorne (2015). Sand transport process measurements under large-scale breaking waves. Coastal Sediments. San Diego, USA: 14 pp.

PROJECTLEADERS

JS Ribberink

RESEARCHTHEME

Complex dynamics of fluids

PARTICIPANTS

J van der Zanden, A Fernández Mora, JJ van der Werf

COOPERATIONS

Deltares
University of Aberdeen, UK
University of Liverpool, UK
Bangor University, UK
Universitat Politècnica de Catalunya
LEGI, Grenoble, Fr
National Oceanography Centre, UK

FUNDED

SINBAD (STW/EPSRC)
Hydralab IV-WISE (EU)
University 80 %
FOM -
STW -
NWO Other -
Industry -
TNO -
GTI -
EU 20 %
Scholarships -

START OF THE PROJECT

2012

INFORMATION

J van der Zanden
053 489 5091
j.vanderzanden@utwente.nl
www.utwente.nl/ctw/wem/

BE SAFE: BIO-ENGINEERING FOR SAFETY USING VEGETATED FORESHORES

PROJECT LEADERS

BW Borsje

RESEARCH THEME

Mathematical and computational methods for fluid flow analysis

PARTICIPANTS

BW Borsje

COOPERATIONS

MIT, University of Cambridge
Antwerp University

FUNDED

STW	
University	-
FOM	-
STW	-
NWO Other	100 %
Industry	-
TNO	-
GTI	-
EU	-
Scholarships	-

START OF THE PROJECT

2015

INFORMATION

BW Borsje
053 489 4038
b.w.borsje@utwente.nl

PROJECT AIM

Bouwen met de natuur is een veelbelovende manier van kustbescherming, welke bijdraagt aan het klimaatbestendig maken van onze kust en zo helpt bij de economische ontwikkeling van de kuststrook. Dit onderzoek bestudeert de stabiliteit van kwelders tijdens storm condities en deze kennis helpt ons om zachte vooroevers te ontwerpen.

PROGRESS

Recently started.

DISSERTATIONS

-

SCIENTIFIC PUBLICATIONS

-

RIVERCARE SUBPROJECT F1: IMPROVING RIVER MANAGEMENT BY ESTIMATING MODEL UNCERTAINTY

PROJECT AIM

In recent years the Room for the River policy programme was implemented in the Dutch river system. This programme consisted of numerous interventions in the river system. RiverCare aims to learn from such large programmes to fundamentally improve the understanding of adaptation in river systems. In subproject F1 we study the validity and uncertainty of models used to quantify the effects of such projects. Our aim is to develop a method for efficient uncertainty estimation for models applied in river engineering.

PROGRESS

The project started in March 2015. This year the research proposal has been written for the discipline board qualifier. A literature review has been carried out on river modeling and uncertainty analysis. Furthermore, an idealized model study with a 2D and 1D numerical model has been set-up and reported.

DISSERTATIONS

-

SCIENTIFIC PUBLICATIONS

1. Berends, K.D., Warmink, J.J., Hulscher, S.J.M.H., Do we have too much confidence in our models?, Book of Abstracts: Bridging gaps between river science, governance and management, NCR-days 2015, Radboud University, Nijmegen, October 1-2, 2015.

PROJECTLEADERS

SJMH Hulscher

RESEARCHTHEME

Mathematical and computational methods for fluid flow analysis

PARTICIPANTS

KD Berends, JJ Warmink

COOPERATIONS

Deltares, Rijkswaterstaat, Witteveen+Bos, HKV Waterbouwkundig Laboratorium (Vlaanderen)

FUNDED

NWO STW (Perspectief)
University -
FOM -
STW 75 %
NWO Other -
Industry 20 %
TNO -
GTI 5 %
EU -
Scholarships -

START OF THE PROJECT

2015

INFORMATION

?

?

?

www.ncr-web.org/rivercare/projects/f1

PROJECT LEADERS

SJMH Hulscher

RESEARCH THEME

Mathematical and computational methods for fluid flow analysis

PARTICIPANTS

RMJ Schielen, A Bomers

COOPERATIONS

University of Utrecht
Rijkswaterstaat, Deltares

FUNDED

Rijkswaterstaat, Deltares
University -
FOM -
STW 83 %
NWO Other -
Industry 17 %
TNO -
GTI -
EU -
Scholarships -

START OF THE PROJECT

2015

INFORMATION

A Bomers
053 489 1062
a.bomers@utwente.nl
www.utwente.nl/ctw/wem/organisatie/medewerkers/bomers/anouk_bomers/

PROJECT AIM

We aim to contribute to improvement of the current estimates of discharge-frequency relationships for the Lower Rhine, which is the primary tool for flood risk management in the lower Rhine delta and directly contributes to the first layer of protection. This study focus on the parametrization of hydraulic characteristics of the river and floodplains of the various historical years and use this as input for the hydraulic models to reconstruct past flood magnitudes.

PROGRESS

This project started in November 2015. Literature is gathered and a research proposal is written, which needs to be presented in June 2016.

DISSERTATIONS

-

SCIENTIFIC PUBLICATIONS

-

SANDBOX – SMART AND SUSTAINABLE DESIGN FOR OFFSHORE OPERATIONS IN A SANDY SEABED

PROJECT AIM

We aim to develop a coupled biogeomorphologic model to increase the understanding of the effects of benthic organisms on the behaviour of coastal bedforms. Using this model we intend to study the spatiotemporal evolution after anthropogenic interventions in shallow coastal seas, together with implementing the concept of ecological landscaping in offshore engineering. This requires integration of knowledge from ecology (subproject 1), fine sediment dynamics (subproject 2) and geomorphology (subproject 3).

PROGRESS

Subproject 3 (Johan Damveld) started in November 2015. The current focus is on writing a research proposal for the qualifier to be defended before the discipline board in May 2016. Furthermore, a literature study is being composed of knowledge on biogeomorphology.

DISSERTATIONS

-

SCIENTIFIC PUBLICATIONS

-

PROJECTLEADERS

SJMH Hulscher

RESEARCHTHEME

Mathematical and computational methods for fluid flow analysis

PARTICIPANTS

JH Damveld, PC Roos, BW Borsje, SJMH Hulscher

COOPERATIONS

Delft University of Technology, NIOZ Yerseke, Boskalis, IMARES, RBINS OD Nature, Dienst der Hydrografie, ACRB, Deltares, Rijkswaterstaat, Dr. F. Heins (independent)

FUNDED

NWO-ALW, Boskalis Westminster University	-
FOM	-
STW	-
NWO Other	89,5 %
Industry	10,5 %
TNO	-
GTI	-
EU	-
Scholarships	-

START OF THE PROJECT

2015

INFORMATION

JH Damveld
053 489 1179
j.h.damveld@utwente.nl

RIVERCARE TOWARDS SELF-SUSTAINING MULTIFUNCTIONAL RIVERS; COMMUNICATION PROGRAMMA OUTCOME: KNOWLEDGE BASE, VISUALISATION AND VIRTUAL RIVER

PROJECT LEADERS

SJM Hulscher, MC van der Voort

RESEARCH THEME

Mathematical and computational methods for fluid flow analysis

PARTICIPANTS

R-J den Haan (G1), J Cortes Arevalo (G2)

COOPERATIONS

Rijkswaterstaat, Deltares, Arcadis, RoyalHaskoningDHV, Witteveen+Bos, HKV, T-Xchange, Tygron

FUNDED

STW (Perspectief: co-funded)

University	-
FOM	-
STW	100 %
NWO Other	-
Industry	-
TNO	-
GTI	-
EU	-
Scholarships	-

START OF THE PROJECT

Subproject G1: 2014

Subproject G2: 2015

INFORMATION

R-J den Haan
r.j.denhaan@utwente.nl

J Cortes Arevalo
v.j.cortesarevalo@utwente.nl

PROJECT AIM

Subproject G1: "A serious gaming environment to support collaborative decision-making in river management" (den Haan)

RQ1: How can the decision-making process in river management be best supported?

RQ2: How should the serious gaming environment support the knowledge transfer to and interactions between the end users?

RQ3: What characteristics should the serious gaming environment have to effectively support the decision-making processes in the case type of stakeholders?

RQ4: What is the effectiveness of the serious gaming environment in supporting the decision-making processes in river management?

Subproject G2: "The potential of web-collaborative platforms to support knowledge exchange in river management" (Cortes Arevalo)

RQ1: Who and what are the roles and needs of data/knowledge providers and users?

RQ2: What are the core-functionalities for the different user groups to support data sharing and knowledge exchange in the web-collaborative platform?

RQ3: How can we test and validate usefulness and applicability criteria according to the context of use?

PROGRESS

For subproject G1, the main focus was dedicated to understanding the river management, the concept and implications of interactive governance found in river management nowadays and how serious gaming can support such processes. Based on literature analysis, the search field and focus for the serious gaming environment has been narrowed down by: (1) framing what the serious gaming environment should do captured in a vision statement; and (2) defining initial design and evaluation criteria. These design and evaluation criteria were subsequently explored further in cooperation with project G2 by means of surveys and focus groups. Current work relates to preparing interview sessions, including a user-centered design approach of scenario co-creation, to be executed in March/April 2016. For subproject G2, the main focus was to get an initial understanding of user the RiverCare web-collaborative platform and the knowledge base behind that platform. So I carried out a review from scientific literature and identified some examples of available platforms. In collaboration with subproject G1, we conducted surveys (Nov and Dec/2015) and focus groups (Oct and Dec/2015) with our user committee and RiverCare researchers colleagues. The findings from these activities were used to refine the vision the tools to be designed. Furthermore, results are being used to prepare the interviews session (March/2016) with target users and a co-creation workshop (May/2016).

DISSERTATIONS

-

SCIENTIFIC PUBLICATIONS

1. Cortes Arevalo, V.J., Hulscher, S.J.M.H., Van der Voort, M.C. The potential of web-collaborative platforms to support knowledge exchange in river management, Book of Abstracts: Bridging gaps between river science, governance and management, NCR-days 2015, Radboud University, Nijmegen, October 1-2, 2015.

FLOODPLAIN REHABILITATION: LINKING PROCESSES TO PATTERNS

PROJECT AIM

Because high and dense vegetation in floodplains causes water safety issues during high water discharges, measures are taken to control the vegetation development in floodplains. Additionally, many of the Dutch floodplains (can) provide important ecosystem services. The difficulty is that the spatio-temporal development of the vegetation and its effects on water safety and nature values is not well understood. Therefore, the aim of this study is to develop a spatially explicit, trait based model that provides insight in the dominant steering processes of floodplain vegetation development, thereby aiding well-founded floodplain management.

PROGRESS

An inventory has been made of existing data bases. A meta-analysis is carried out to link processes via environmental filters to plant traits. Currently plans are made for field work in three Dutch floodplains.

DISSERTATIONS

-

SCIENTIFIC PUBLICATIONS

1. V. Harezlak, D.C.M. Augustijn, G.W. Geerling, S.J.M.H. Hulscher en R.S.E.W. Leuven (2015): "Floodplain rehabilitation: linking processes to patterns", in Lenders, H.J.R., F.P.L. Collas, G.W. Geerling, R.S.E.W. Leuven (Eds.), 2015, Bridging gaps between river science, governance and management. NCR-Days 2015, Book of Abstracts, NCR Publication 39-2015, Netherlands Centre for River Studies, Enschede. ISSN 1568-234X - <http://www.ncr-web.org/ncr-days/publications>

PROJECTLEADERS

SJMH Hulscher, DCM Augustijn

RESEARCHTHEME

Mathematical and computational methods for fluid flow analysis

PARTICIPANTS

V Harezlak, RSEW Leuven

COOPERATIONS

Rijkswaterstaat, Deltares, RIVM, Bureau Waardenburg, Arcadis

FUNDED

STW Perspectief

University -

FOM -

STW 60 %

NWO Other -

Industry 10 %

TNO -

GTI 30 %

EU -

Scholarships -

START OF THE PROJECT

2015

INFORMATION

V Harezlak

053 489 4386

v.harezlak@utwente.nl

<https://www.utwente.nl/ctw/wem/>

[organisatie/medewerkers/harezlak/](https://www.utwente.nl/ctw/wem/organisatie/medewerkers/harezlak/)

OPTIMIZING WATER AVAILABILITY WITH SENTINEL-1 SATELLITES (OWAS1S)

PROJECT LEADERS

SJMH Hulscher

RESEARCH THEME

Complex dynamics of fluids

PARTICIPANTS

M Pezij, DCM Augustijn,

DMD Hendriks

COOPERATIONS

University of Twente, Wageningen

University, Deltares, Province of

Overijssel, Waterschap Aa en Maas

Waterschap Vechtstromen,

Waterschap Groot Salland,

Hoogheemraadschap De Stichtse

Rijnlanden, ZLTO, HKV, HydroLogic,

Rijkswaterstaat, STOWA, Vienna

University of Technology

FUNDED

STW, Regional Water Authorities,

Province of Overijssel, Deltares

University -

FOM -

STW 85 %

NWO Other -

Industry 15 %

TNO -

GTI -

EU -

Scholarships -

START OF THE PROJECT

2015

INFORMATION

M Pezij

053 489 31 69

m.pezij@utwente.nl

www.utwente.nl/ctw/wem/

PROJECT AIM

This project is part of the larger OWAS1S-project to optimize water availability with Sentinel-1 satellites. The focus of this subproject is the optimization of operational water management using soil moisture data. First, clear criteria for optimizing water availability will be defined in cooperation with users. Thereafter, new remotely sensed soil moisture maps will be used to improve the performance of existing hydrological models (e.g. NHI). The improved model will be applied to historic cases to optimize for example crop water availability based on the pre-defined criteria. These cases will involve two case studies: the Twente region and the catchment of the Raam (Noord Brabant). Based on these results, it might be possible to develop new operational/strategic water management strategies in cooperation with users.

PROGRESS

As this project started in the end of 2015, there is not a lot of output generated at the moment. All the users had the chance to express their expectations of the project during the first users committee meeting. Based on this, every PhD-student started making his/her research plan and literature study which should be finished in April/May 2016. Also, a new soil moisture measuring network is going to be set-up. The first preparations for setting-up this network were performed in December 2015. The project members are discussing at the moment what the requirements of this network should be.

DISSERTATIONS

-

SCIENTIFIC PUBLICATIONS

-

ON THE DYNAMICS OF SIDE CHANNELS AS REHABILITATION MEASURE: LINKING THEORY AND PRACTICE

PROJECT AIM

The construction of a side channel is a popular method to restore the river's ecology and to lower the water level during floods. However, due to erosion and sedimentation processes in the side channel, regular maintenance is required. An optimal design of a side channel minimizes the costs of maintenance, but the knowledge of the processes in and around a side channel is yet not sufficient. The goal of this research is to reduce the amount of required maintenance in side channels and to gain a better understanding of the hydrodynamic and morphodynamic processes in a side channel system.

PROGRESS

In the past year, the research proposal was written and defended. Several side channel systems in Europe and USA were studied to identify the main processes and characteristics which influence the evolution of the system. Using a 1D numerical model the effects of these processes and characteristics on the evolution of a side channel system were investigated.

DISSERTATIONS

-

SCIENTIFIC PUBLICATIONS

1. van Denderen, R.P., Schielen, R.M.J., Hulscher, S.J.M.H. Observed evolution of side channels, Book of Abstracts: Bridging gaps between river science, governance and management, NCR-days 2015, Radboud University, Nijmegen, October 1-2, 2015.

PROJECTLEADERS

RMJ Schielen

RESEARCHTHEME

Mathematical and computational methods for fluid flow analysis

PARTICIPANTS

RP van Denderen, SJMH Hulscher, A Blom, MG Kleinhans

COOPERATIONS

Rijkswaterstaat, LievenseCSO, RoyalhaskoningDHV, HKV consultants

FUNDED

STW (Perspective programme P12-14), Rijkswaterstaat, LievenseCSO, RoyalhaskoningDHV, HKV consultants

University	-
FOM	-
STW	60 %
NWO Other	-
Industry	15 %
TNO	-
GTI	-
EU	25 %
Scholarships	-

START OF THE PROJECT

2014

INFORMATION

RP van Denderen
r.p.vandenderen@utwente.nl

BE SAFE: BIO-ENGINEERING FOR SAFETY USING VEGETATED FORESHORES

PROJECT LEADERS

SJMH Hulscher

RESEARCH THEME

Mathematical and computational methods for fluid flow analysis

PARTICIPANTS

PWJM Willemsen, BW Borsje

COOPERATIONS

TuDelft, NIOZ Yerseke

FUNDED

Boskalis, Van Oord, Deltares, ALW

University -

FOM -

STW -

NWO Other 50 %

Industry 50 %

TNO -

GTI -

EU -

Scholarships -

START OF THE PROJECT

2014

INFORMATION

PWJM Willemsen

053 489 4198

p.w.j.m.willemsen@utwente.nl

PROJECT AIM

We aim to develop new methods to assess how, and how much vegetated foreshores can contribute to flood risk reduction. The project will lead to a better understanding of (uncertainties in) the functioning and stability of these ecosystems and the development of novel governance arrangements. This requires integration of knowledge from ecology, biogeomorphology, hydraulic engineering, and governance.

PROGRESS

By field observations on several sites and flume measurements we analysed fundamental ecological and physical processes for various types of wetland vegetations. The knowledge obtained will be applied in one implementation case study for a location in the Netherlands where dike reinforcement is needed. This case study integrates fundamental knowledge from all the disciplines. It is used to design governance and implementation arrangements, and to demonstrate how vegetated foreshores can contribute to flood risk reduction.

DISSERTATIONS

-

SCIENTIFIC PUBLICATIONS

-





Prof.dr.ir. RWCP Verstappen



Prof.dr.ir. AEP Veldman

The group Computational Mechanics and Numerical Mathematics at the University of Groningen focuses on the development of numerical solution methods for partial differential equations in general, and for (aero- and hydrodynamic) flow simulation in particular (CFD). Keywords for our algorithmic developments are symmetry-preserving discretization, Cartesian cut-cell approach, sharp-interface methods, efficient sparse-matrix solvers and large-scale continuation methods. It is our strategy to combine all algorithmic innovations from the individual research projects into one coherent CFD concept, such that all projects can profit from each other.

Application areas are direct and large-eddy simulation of turbulent flow, free-surface flow in aerospace (sloshing onboard spacecraft) and maritime engineering (hydrodynamic wave loading), oceanography (stability of the global ocean circulation), bio-medical fluid dynamics (hemodynamics) and heat transport (Rayleigh-Bénard flow). We plan to extend our research efforts towards multi-physics: fluid-structure interaction, two-phase flow, atmospheric flow and turbulent combustion. In the process of knowledge transfer, the in-house developed computer codes ComFlo and MRILU play an important role.

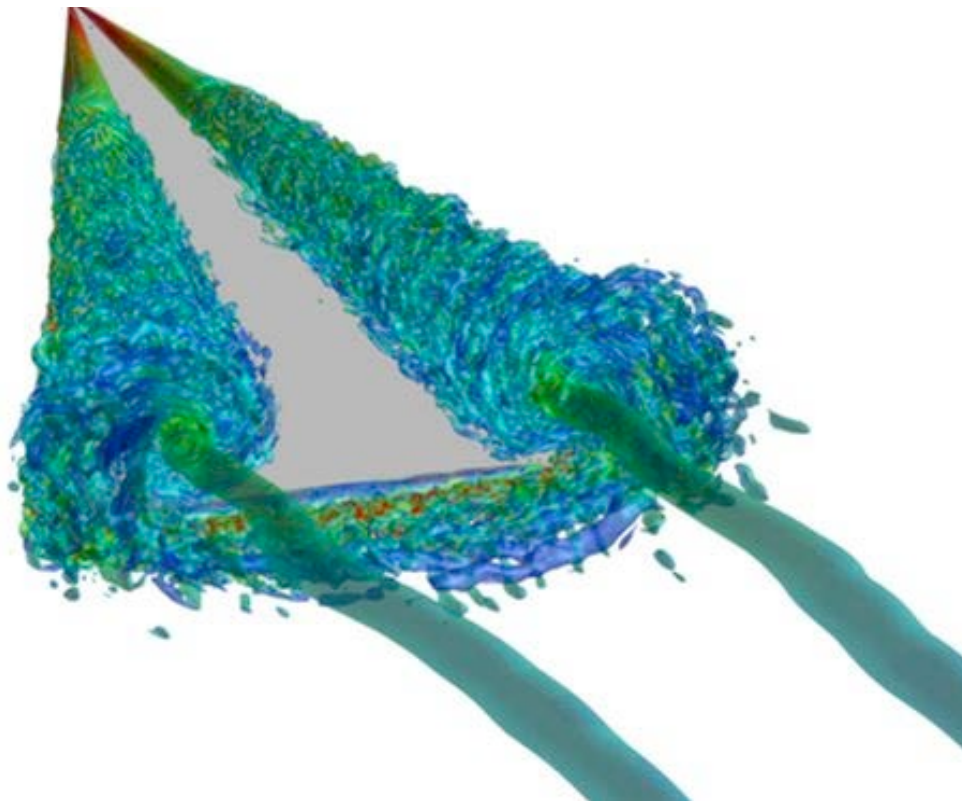

DNS of flow past a delta wing at $Re=200,000$.

DIRECT AND LARGE-EDDY SIMULATION OF TURBULENCE

PROJECT AIM

Our project concentrates on improving numerical techniques for direct numerical simulation (DNS) of turbulence, as well as on large-eddy simulation (LES). Finding a closure model represents the main difficulty to LES. Because turbulence is so far from being completely understood, there is a wide range of models, mostly based on heuristic arguments. The aim of the present project is to construct a class of LES-models that preserves (symmetry) properties of the Navier-Stokes equations, and ensures that the nonlinear dynamics is truncated properly, meaning that the formation of fine details is counterbalanced by the model.

PROGRESS

In cooperation with NLR a PhD project was completed in which low-dissipation discretizations for subsonic turbulent flows and minimum-dissipation models for LES are developed. In a parallel project the low-dissipation methods and models are extended to unstructured grids, in cooperation with MARIN. The joint work with Stanford University (Center for Turbulence Research) has resulted into a journal paper. The PhD project on scale truncation models for LES has led to a list of requirements that a subgrid model should satisfy in order to it conforms to symmetry and conservation properties of the Navier-Stokes equations.

DISSERTATIONS

1. W. Rozema, Low-dissipation methods and models for the simulation of turbulent subsonic flow: Theory and applications, University of Groningen, 193pp, 2015.

SCIENTIFIC PUBLICATIONS

1. W. Rozema, H.J. Bae, P. Moin, R. Verstappen, Minimum-dissipation models for large-eddy simulation, *Physics of Fluids* 27, 085107 (2015); doi 10.1063/1.4928700, 14 pages.
2. M.H. Silvis, R. Verstappen, Physically-consistent subgrid models for large-eddy simulation of incompressible turbulent flows, arXiv: 1510.07881 (2015).
3. R. Verstappen, On Scale Separation in Large Eddy Simulation. In: *Direct and Large-Eddy Simulation IX* J. Frolich, J. Kuerten, B.J. Geurts, V. Armenio (eds.), ERCOFTAC Series Vol 20, Springer, Berlin, 3--14, 2015.
4. F.X. Trias, A. Gorobets, A. Oliva and R.W.C.P. Verstappen, New Differential Operators for Large-Eddy Simulation and Regularization Modeling. In: *Direct and Large-Eddy Simulation IX* J. Frolich, J. Kuerten, B.J. Geurts, V. Armenio (eds.), ERCOFTAC Series Vol 20, Springer, Berlin, 29--36, 2015.
5. W. Rozema, R.W.C.P. Verstappen, J.C. Kok and A.E.P. Veldman, A Symmetry-Preserving Discretization and Regularization Subgrid Model for Compressible Turbulence. In: *Direct and Large-Eddy Simulation IX* J. Frolich, J. Kuerten, B.J. Geurts, V. Armenio (eds.), ERCOFTAC Series Vol 20, Springer, Berlin, 319--326, 2015.
6. R. Verstappen, Truncation of Scales by Relaxation. In: *Proceedings of the 15th European Turbulence Conference (ETC15)*, 25-28 August, 2015, Delft.
7. M. Silvis and R. Verstappen, Going Beyond Eddy Viscosity: Finding a Minimal Representation of Subgrid Scale Stresses in Large Eddy Simulation In: *Proceedings of the 15th European Turbulence Conference (ETC15)*, 25-28 August, 2015, Delft.

PROJECTLEADERS

RWCP Verstappen

RESEARCHTHEME

Mathematical and computational methods for fluid flow analysis

PARTICIPANTS

HJ Bandringa, AJA Kort, JA Helder, W Rozema, MH Silvis, FW Wubs, AEP Veldman, FX Trias (UPC), A Oliva (UPC), HJ Bae (CTR), P Moin (CTR)

COOPERATIONS

NLR, MARIN, TUD, UT, Polytechnical University of Catalunya (UPC), Stanford University (CTR)

FUNDED

Maritiem Innovatieprogramma (EZ), NWO, Ubbo Emmius Fonds (RuG)

University	30 %
FOM	-
STW	-
NWO Other	40 %
Industry	10 %
TNO	-
GTI	-
EU	10 %
Scholarships	10 %

START OF THE PROJECT

1998

INFORMATION

RWCP Verstappen
050 363 3958
R.W.C.P.Verstappen@rug.nl
www.rug.nl/staff/r.w.c.p.verstappen

8. R. Verstappen, Scale Truncation in Large Eddy Simulation of Turbulent Flow by Regularization. In: Proceedings of the 8th International Congress on Industrial and Applied Mathematics (ICIAM), August 10-14, Beijing.
9. H.J. Bae, W. Rozema, P. Moin, R. Verstappen, Minimum-dissipation models for large-eddy simulation, 68th Meeting APS Division Fluid Dynamics, 22-24 November 2015, Boston Bulletin of the American Physical Society, Vol. 60 No. 21 p. 118, 2015.
- 10 R. Verstappen, M. Silvis Scale-truncating relaxation models for large-eddy simulations, 68th Meeting APS Division Fluid Dynamics, 22-24 November 2015, Boston, Bulletin of the American Physical Society, Vol. 60 No. 21 p. 418, 2015.

PARALLEL BLOCK MULTILEVEL INCOMPLETE LU FACTORIZATION PRECONDITIONERS FOR THE NAVIER-STOKES EQUATIONS

PROJECT AIM

The solution of large block structured linear systems arising from an implicit formulation of the Reynolds Averaged Navier-Stokes equations, using Newton-Krylov methods, requires ad-hoc preconditioners for inverting the large nonsymmetric linear system at each step of the Newton's algorithm. In this project we develop a new MPI-based variable block multilevel algebraic recursive iterative solver that detects automatically exact or approximate dense structures in the coefficient matrix and exploits them to maximize computational efficiency. The performance of the new method are assessed on a suite of two- and three-dimensional realistic test cases.

PROGRESS

A fully parallel MPI-based implementation of a new variable block multilevel Incomplete LU factorization preconditioner has been developed for solving nonsymmetric linear systems. The performance of the new preconditioner are assessed for solving turbulent Navier-Stokes equations on a suite of two- and three-dimensional test cases, among which the calculation of the flow past the DPW3-W1 wing configuration of the third AIAA Drag Prediction Workshop. These analyses are carried out with coarse to medium-sized grids featuring up to 2.5 million nodes at Reynolds number equal to $5 \cdot 10^6$. The results show that the solver may be noticeably more robust than other state-of-the-art solvers at comparable memory usage.

DISSERTATIONS

1. Jia Liao - University of Groningen - Faculty of Mathematics and Natural Sciences. Title : VBARMS: A variable block algebraic recursive multilevel solver for sparse linear systems.

SCIENTIFIC PUBLICATIONS

1. Z.-Li Shen, T.-Z. Huang, B. Carpentieri and C. Wen, A Cost-Effective Smoothed Multigrid with Modified Neighborhood-Based Aggregation for Markov Chains. *Mathematical Problems in Engineering*, 2015, article ID 816935, 15 pages. <http://dx.doi.org/10.1155/2015/816935>.
2. X.-M. Gu, T.-Z. Huang, B. Carpentieri, L. Li and C. Wen. A hybridized iterative algorithm of the BiCORSTAB and GPBiCOR methods for solving non-Hermitian linear systems. *Computers & Mathematics with Applications*, vol. 70, 2015, pp. 3019-3031. doi:10.1016/j.camwa.2015.10.012.
3. R. Albanese, B. Carpentieri, M. Cavinato, S. Minucci, R. Palmaccio, A. Portone, G. Rubinacci, P. Testoni, S. Ventre, F. Villone. Effects of asymmetric vertical disruptions on ITER components. *Fusion Engineering and Design*, vol. 94, 2015, Pages 7–21. doi:10.1016/j.fusengdes.2015.02.034.
4. Parallel variable block algebraic multilevel iterative solution for large-scale turbulent problems. J. Liao, B. Carpentieri and M. Sosenkina. Burgersdag, Delft, Netherlands, 2015.
5. A parallel multilevel incomplete LU factorization preconditioner that exploits block matrix structures. J. Liao, A. Bonfiglioli, B. Carpentieri, M. Sosenkina ParCFD, Montreal, Canada, 2015.
6. A parallel multilevel incomplete LU factorization preconditioner that exploits block matrix structures. J. Liao, B. Carpentieri, M. Sosenkina. Preconditioning 2015, Eindhoven, The Netherlands, 2015.
7. Parallel multilevel incomplete LU factorization preconditioner with variable-block structure. M. Sosenkina, B. Carpentieri, J. Liao, SIAM LA 2015, Atlanta, GA, 2015.

PROJECT LEADERS

B Carpentieri

RESEARCH THEME

Mathematical and computational methods for fluid flow analysis

PARTICIPANTS

B Carpentieri, J Liao

COOPERATIONS

Prof. Aldo Bonfiglioli, Scuola di Ingegneria, University of Basilicata, Potenza, Italy, Prof. Masha Sosenkina Department of Modeling, Simulation & Visualization Engineering - Old Dominion University, Norfolk, US 23529

FUNDED

RUG	
University	100 %
FOM	-
STW	-
NWO Other	-
Industry	-
TNO	-
GTI	-
EU	-
Scholarships	-

START OF THE PROJECT

2011

INFORMATION

B Carpentieri
050 363 8991
b.carpentieri@rug.nl
www.rug.nl/staff/b.carpentieri/

NUMERICAL METHODS FOR THE INCOMPRESSIBLE NAVIER-STOKES EQUATIONS

PROJECT LEADERS

FW Wubs

RESEARCH THEME

Mathematical and computational methods for fluid flow analysis

PARTICIPANTS

W Song (DLR/RUG), S Kotnala (RUG), S Baars (RUG), E. Mulder (IMAU), H.A Dijkstra (IMAU), J Thies (DLR).

COOPERATIONS

IMAU (UU), TUE, DLR, TU Braunschweig, TU Cologne

FUNDED

NWO, University of Groningen, DLR University	25 %
FOM	-
STW	-
NWO Other	50 %
Industry	25 %
TNO	-
GTI	-
EU	-
Scholarships	-

START OF THE PROJECT

1994

INFORMATION

FW Wubs
050 363 3994
f.w.wubs@rug.nl
www.math.rug.nl/~wubs

PROJECT AIM

The aim of this project is provide fast and robust solvers for the study of dynamics and structures of incompressible fluids. Such solvers are necessary for among others (i) the coupled linear system arising from steady or implicit computations of fluid flow, (ii) the computation of eigenvalues to study the stability of a flow and (iii) the solution of a stochastic PDE to study the influence of noise on the stability of flows. The focus is on geophysical flows and flows in simple geometries.

PROGRESS

The Jacobi-Davidson QR method available in PHIST (<https://bitbucket.org/essesex/phist/>) has been extended to non-symmetric generalized eigenvalue problems appearing in stability computations for incompressible fluid flow problems. Moreover, a lot of effort has been spent on developing a generalized Lyapunov solver to compute part of the covariance matrix of large scale ocean models affected by noisy data at the surface. A first version is now tested on a zonally averaged ocean model and compared to existing methods.

The tailored THCM solver has been expanded with an atmospheric model including a solver for the combined system. Finally, For our linear solver package HYMLS we implemented as test problems the differentially heated cavity, with and without rotation and a Turing problem.

DISSERTATIONS

-

SCIENTIFIC PUBLICATIONS

-

COMMOTION: COMPUTATIONAL METHODS FOR MOVING AND DEFORMING OBJECTS IN EXTREME WAVES

PROJECT AIM

In the ComFLOW project, together with the maritime industry, concerns the design of numerical simulation methods for extreme waves and their impact on floating and moored constructions like offshore platforms and coastal protection systems. The most recent development phase concerns the interaction of extreme waves and floating and/or deforming bodies.

PROGRESS

The previous phase of the ComFLOW project has been finished with the release of version 3.9.5. In the new phase, called ComMotion, several extensions to the method are being designed featuring the interaction with moving and deforming objects. For the numerical coupling between solid-body dynamics and fluid dynamics a quasi-simultaneous class of methods is developed that is stable for any added-mass ratio. With the same approach, the coupling with elastically deforming objects can be simulated in a numerically stable way. Further, the influence of current is studied; an important ingredient is an absorbing boundary condition, generalizing the work of Duz (who defended his PhD thesis). Finally, local grid refinement and parallelization enhance the simulation efficiency.

DISSERTATIONS

1. B. Duz. Wave generation, propagation and absorption in CFD simulations for free-surface flows. Promotors: R.H.M. Huijsmans, A.E.P. Veldman. PhD thesis, Delft University of Technology, September 21, 2015.

SCIENTIFIC PUBLICATIONS

1. B. Duz, R.H.M. Huijsmans, P.R. Wellens, M.J.A. Borsboom, A.E.P. Veldman and R. Luppés. Generating and absorbing boundary conditions for free-surface flow simulations in offshore applications. Proc. 34th Int. Conf. Ocean, Offshore and Arctic Engng OMAE2015, St. John's (Canada), 31 May--5 June 2015, paper OMAE2015-41577.
2. H.J.L. van der Heiden, A.E.P. Veldman, R. Luppés, P. van der Plas, J. Helder and T. Bunnik. Turbulence modeling for free-surface flow simulations in offshore applications. Proc. 34th Int. Conf. Ocean, Offshore and Arctic Engng OMAE2015, St. John's (Canada), 31 May--5 June 2015, paper OMAE2015-41578.
3. P. van der Plas, A.E.P. Veldman, H.J.L. van der Heiden and R. Luppés. Adaptive grid refinement for free-surface flow simulations in offshore applications. Proc. 34th Int. Conf. Ocean, Offshore and Arctic Engng OMAE2015, St. John's (Canada), 31 May--5 June 2015, paper OMAE2015-42029.
4. A.E.P. Veldman, R. Luppés, P. van der Plas, H.J.L. van der Heiden, J. Helder and T. Bunnik. Turbulence modeling for locally-refined free-surface flow simulations in offshore applications. Proc. Int. Symp. Offshore and Polar Engng. ISOPE2015, 23-27 June 2015, Kona (Hawaii), paper 2015-TPC-0282.
5. A.E.P. Veldman, R. Luppés, P. van der Plas, H.J.L. van der Heiden, J. Helder and T. Bunnik. Numerical simulation of turbulent free-surface flow in offshore applications. In: F. Salvatore, R. Broglia and R. Muscari (eds) VI International Conference on Computational Methods in Marine Engineering MARINE 2015, 15-17 June 2015, Rome, pp. 963-980.
6. R. Wemmenhove, R. Luppés, A.E.P. Veldman and T. Bunnik. Numerical simulation of hydrodynamic wave loading by a compressible two-phase flow method. Comp. Fluids, 114 (2015) 218-231.

PROJECT LEADERS

AEP Veldman

RESEARCH THEME

Mathematical and computational methods for fluid flow analysis

PARTICIPANTS

P van der Plas, H Seubers, HJL van der Heiden, AEP Veldman, R Luppés (RUG), M Hosseini, X Chang, B Duz, I Akkerman, RHM Huijsmans (TUD), J Helder, T Bunnik (MARIN), B Iwanowski (FORCE), P Wellens, M Borsboom (Deltares)

COOPERATIONS

TU Delft, MARIN, FORCE Technology (Norway), Deltares, GustoMSC, Damen Shipyards

FUNDED

STW	
University	-
FOM	-
STW	100 %
NWO Other	-
Industry	-
TNO	-
GTI	-
EU	-
Scholarships	-

START OF THE PROJECT

1999

INFORMATION

AEP Veldman
050 363 3988
a.e.p.veldman@rug.nl
www.math.rug.nl/~veldman/comflow/
comflow.html

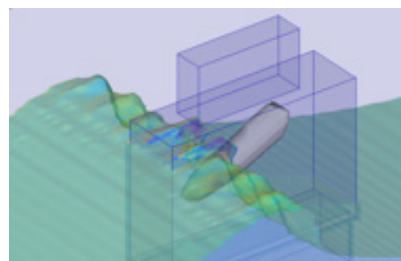

Numerical simulation (with local grid refinement) of a lifeboat falling into a breaking wave.

EXPERIMENTAL ZOOLOGY GROUP



Prof.dr.ir. JL van Leeuwen

The mission of the Experimental Zoology Group is to unravel the relationships between form and function in zoological systems in a developmental and evolutionary context and to provide bioinspired solutions for technological and health problems. The current main research area of the Experimental Zoology Group is the biomechanics of motion systems in vertebrates and insects, with three research lines that profit from one another: (1) Biomechanics of animal flight, including the biofluid dynamics of avian and insect flight and in-flight host detection of malaria mosquitoes. (2) Biomechanics of fish swimming, including swimming and developmental mechanics in larval fish, fin propulsion, visuo-motor-system development and effects of a livebearing reproductive strategy on swimming performance. This research line also includes developmental mechanics of bones and muscles linking bone remodelling to molecular regulation. (3) Bioinspired design solutions for human health, including development of steerable needles (inspired by the mechanics of the ovipositor in parasitic wasps), and construction of gentle grippers for delicate human tissues (inspired by wet adhesion of toe-pads in tree frogs). The Experimental Zoology Group participates also within the graduate school Wageningen Institute of Animal Sciences (WIAS).

FLUID-MUSCLE INTERACTION OF FREE-SWIMMING ZEBRAFISH LARVAE

PROJECT AIM

Zebrafish larvae start swimming within two days post fertilization (2 dpf), and develop rapidly over the next few days. We propose to study how these developmental changes affect locomotory performance. To achieve this, we will create a numerical model of the larvae that accounts for the mechanics of the muscular system, the external fluid mechanics, and their mutual interactions. This approach allows us to unravel how muscle activation patterns lead to swimming motions and identify causes of changes in swimming performance across development.

PROGRESS

To quantify the swimming motions of the larval zebrafish, we created a large database of multiple-camera high-speed video of their swimming repertoire across development, from day 2 until 12 after fertilization. We developed software that tracks the fish in three-dimensions from these data and computes the net force and torque on the body(2). The resulting three-dimensional surface descriptions of the fish are used as input for CFD-simulations, to compute flow fields and force distributions. Furthermore, we made an experimental analysis of the non-linear relationship between Strouhal number and Reynolds number in the swimming larvae(1). Through an NWO/ALW-grant, we acquired equipment to measure muscle activation of zebrafish in vivo, after having demonstrated the feasibility in a pilot experiment. At a later stage, these models and data will be combined into the final integrative fluid-structure interaction model of larval fish swimming.

DISSERTATIONS

-

SCIENTIFIC PUBLICATIONS

1. Van Leeuwen JL, Voesenek CJ, Müller UK. How body torque and Strouhal number change with swimming speed and developmental stage in larval zebrafish. *Journal of The Royal Society Interface*. 2015 Sep 6;12(110):20150479.
2. Voesenek CJ, Pieters RP, Leeuwen JL. Automated Reconstruction of Three-Dimensional Fish Motion, Forces, and Torques. *PLOS ONE*. 2016 Jan 1;11(1).

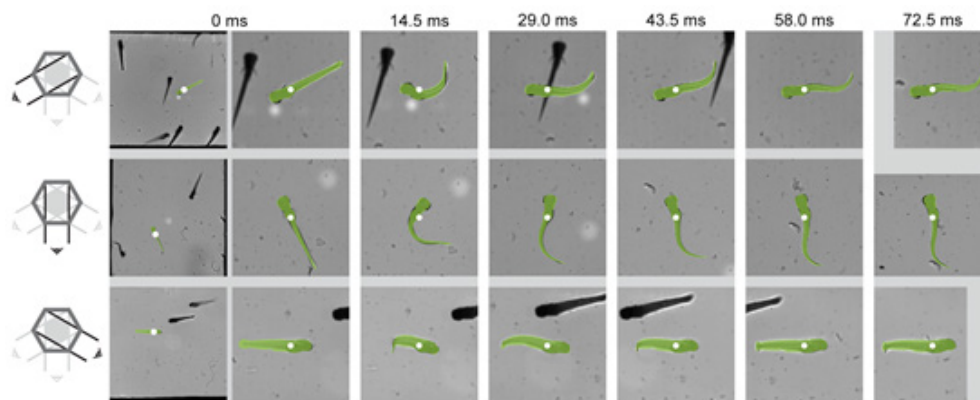

Reconstructed fast start escape response of a zebrafish larva, three days post fertilization. The tracked fish (green) is overlaid on high-speed video images from three different camera angles, used to reconstruct the three-dimensional motion (based on ref (2)).

PROJECT LEADERS

JL van Leeuwen

RESEARCH THEME

Complex dynamics of fluids

PARTICIPANTS

MJM Lankheet, FT Muijres, CJ Voesenek

COOPERATIONS

H Liu (Chiba U, Japan), UK Müller (CSU Fresno, USA)

FUNDED

NWO-ALW	
University	20 %
FOM	-
STW	-
NWO Other	80 %
Industry	-
TNO	-
GTI	-
EU	-
Scholarships	-

START OF THE PROJECT

2012

INFORMATION

JL van Leeuwen
0317 482267
johan.vanleeuwen@wur.nl
www.ezo.wur.nl

AERODYNAMICS OF HIGH-FREQUENCY FLAPPING WINGS IN FLYING MOSQUITOES

PROJECT LEADERS

FT Muijres

RESEARCH THEME

Complex dynamics of fluids

PARTICIPANTS

JL van Leeuwen

WG van Veen (PhD candidate)

COOPERATIONS

-

FUNDED

Wageningen University

University 50 %

FOM -

STW -

NWO Other 50 %

Industry -

TNO -

GTI -

EU -

Scholarships -

START OF THE PROJECT

2015

INFORMATION

FT Muijres

0317 486977

florian.muijres@wur.nl

<http://www.ezo.wur.nl>

PROJECT AIM

Mosquitos fly at an exceptionally high wingbeat frequency which sets them apart from other flying insects. The goal of this project is to understand the aerodynamics behind high-frequency flapping mosquito flight. The project started in 2015.

PROGRESS

We filmed 21 flying malaria mosquitoes using three high-speed video cameras (Photron SA-X2), operating at 13,500 frames per second. At an average wingbeat frequency of 600 Hz, this resulted in roughly 22 video frames per wingbeat. Using a machine-vision based tracking algorithm, we reconstructed the body and wing movement throughout the 484 measured wingbeats (Figure 1). Next to this, we used Computational Fluid Dynamics (CFD) to estimate the lift coefficient (CL) and drag coefficient (CD) of rotating mosquito wings at a range of angles-of-attack (Figure). Based on the resulting CL and CD polars in combination with the temporal dynamics of wing velocity and angle-of-attack throughout each wingbeat, we estimated the quasi-steady aerodynamic forces on the flapping mosquito wings. Comparing the outcome of the quasi-steady model with the body weight of the hovering mosquitoes shows that the quasi-steady forces account for 86% of weight support.

DISSERTATIONS

-

SCIENTIFIC PUBLICATIONS

-

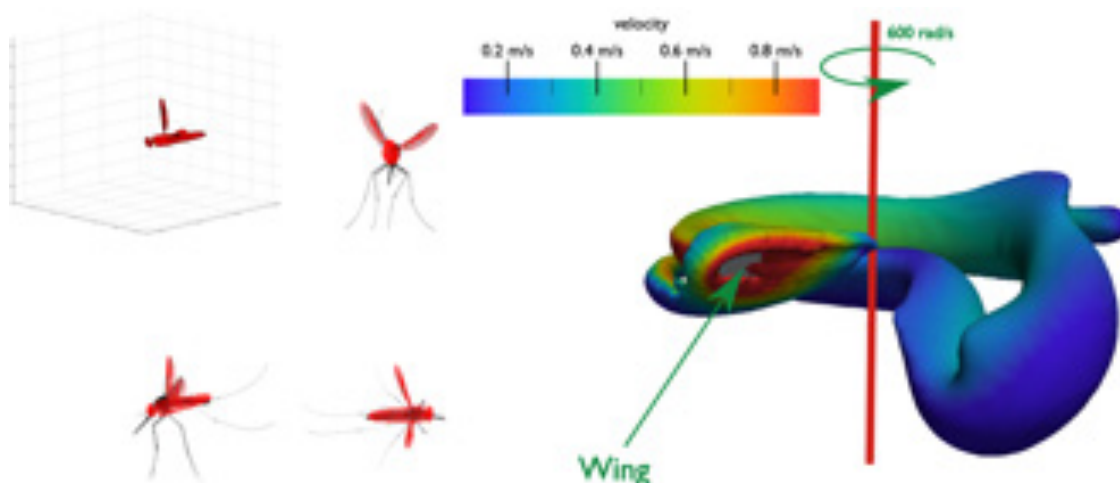

The mosquito tracker output consisting of the 3D mosquito body and wing model and video images with the model projected onto them (left). CFD simulation of a mosquito wing model at 54° angle-of-attack and rotating at 600 rad/s. Contour of the q-criterion coloring with the local flow velocity (right).





Prof.dr.ir. CGPH Schroën

Microtechnology, membranes and modelling: M3

Membranes (and other microstructures) can be used for various purposes, such as separation, which is the traditional application for membranes, but also for formation of emulsions, foams, and sprays. Within the food microtechnology group, all these aspects are investigated (together with technical assistants Jos Sewalt and Maurice Strubel), and modelling is used as a tool to gain fundamental insight in the underlying mechanisms, together with colleagues Ruud van der Sman and Maarten Schutyser. For specific information on projects, please consult the pages indicated below, and the PhD thesis section which holds completed projects.

MODELLING CROSS FLOW MICROFILTRATION: DESIGN FOR THE CONCENTRATION AND FRACTIONATION OF SUSPENSIONS

PROJECT AIM

This PhD project aims at modeling of particle behavior in flow through micro channels. During this process particles will migrate, and these effects can be used to facilitate amongst other microfiltration but also separation processes. Through detailed understanding of particle behavior we will design novel separation processes that are expected to be intrinsically more energy efficient than those that are currently available.

PROGRESS

Starting from experimental results obtained in previous research, we started with a simple system, i.e. a microchannel, through which a particle containing dispersion flows, and modelled this with Star CCM software. We were able to generate concentration gradients that resemble those that were experimentally found in literature. We now extend this system to include pores, and investigate the separation process.

DISSERTATIONS

-

SCIENTIFIC PUBLICATIONS

-

PROJECT LEADERS

K Schroën

RESEARCH THEME

Complex dynamics of fluids

PARTICIPANTS

I Drijer

COOPERATIONS

The project is part of the NanoNextNI program, and within that the water theme. We cooperate with UTwente, and Stork Veco.

FUNDED

NanoNextN1	
University	-
FOM	-
STW	-
NWO Other	100 %
Industry	-
TNO	-
GTI	-
EU	-
Scholarships	-

START OF THE PROJECT

2012

INFORMATION

K Schroën
0317 483396
karin.schroen@wur.nl
<http://www.wageningenur.nl/en/Expertise-Services/Chair-groups/Agrotechnology-and-Food-Sciences/Food-Process-Engineering/Research/Food-microtechnology.htm>



Prof.dr. LRM Maas

Research in this theme focuses on the interactions between the water motion, sediment transport and bottom changes in coastal seas and estuaries. Both sandy and mud-dominated coastal systems are investigated. The following approaches are used to gain more understanding of hydrodynamic and morphodynamic processes: collection and analysis of field observations, simulations with complex numerical models and interpretation of these results, development and analysis of idealized mathematical models.

THE EQUATORIAL BOUNDARY LAYER

PROJECT AIM

The project aims at understanding the equatorial ocean, both from theoretical as well as observational perspective. Physical arguments exist that predict such a rapid change since the usual neglect of the tangential component of the earth vorticity vector (in favor of the component normal to the earth surface) can no longer hold near the equator.

PROGRESS

Observations in the near-equatorial region in the Atlantic Ocean (ranging from 0 to 2 degrees North) show dramatic changes in several properties compared to higher latitudes (such as in wave polarity, turbulence intensity, presence of deep zonal jets, stepwise density structure, etc).

DISSERTATIONS

-

SCIENTIFIC PUBLICATIONS

-

PROJECTLEADERS

LRM Maas

RESEARCHTHEME

Complex dynamics of fluids

PARTICIPANTS

Anna Rabitti (PhD student), Hans van Haren and Theo Gerkema

COOPERATIONS

-

FUNDED

NIOZ	
University	-
FOM	-
STW	-
NWO Other	100 %
Industry	-
TNO	-
GTI	-
EU	-
Scholarships	-

START OF THE PROJECT

2010

INFORMATION

LRM Maas
0222 369419
maas@nioz.nl
www.nioz.nl



Prof.dr.ir. HA Dijkstra

DYNAMICAL OCEANOGRAPHY AT IMAU

In my group, we study the role of the ocean circulation in the variability of the climate system and the processes controlling the large-scale ocean circulation.

Focus of work in on the path changes of ocean western boundary currents (such as the Gulf Stream in the Atlantic, the Kuroshio in the Pacific and the Agulhas near South Africa), the El Nino/Southern Oscillation phenomenon in the Pacific and the North Atlantic Multidecadal variability. Both theory development and (high-resolution) model simulation are used to understand these phenomena and our favorite framework to analyse the complex behavior of ocean flows is that provided by stochastic dynamical systems theory.

PREDICTABILITY OF KUROSHIO CURRENT PATH TRANSITIONS

PROJECT AIM

Our objectives are (i) to develop a unifying theory of the Kuroshio path variability, (ii) to assess the decadal time scale predictability of these path transitions, (iii) to determine the effects of the large-scale barotropic instabilities, meso-scale eddies and wind-stress variations on this predictability and (iv) to study of impact of different observational data on the prediction skill of the models used.

PROGRESS

The study on the transitions between paths of the Kuroshio using a network approach has been completed [1]. Intrinsic variability of the Antarctic Circumpolar Current was considered in [2]. A review on the physics of the Kuroshio Current and its predictability has been published in [3].

DISSERTATIONS

-

SCIENTIFIC PUBLICATIONS

-

PROJECT LEADERS

HA Dijkstra

RESEARCH THEME

Complex dynamics of fluids

PARTICIPANTS

J Viebahn

COOPERATIONS

Dr. Fred Wubs (RUG), Prof. T.

Sapsis (MIT, MA, USA), Prof. Mu Mu

(IOCAS, Qingdao, China), Prof. S.

Pierini (Univ. Naples, Naples, Italy)

FUNDED

NWO-EW (COMPLEXITY)

University -

FOM -

STW -

NWO Other 100 %

Industry -

TNO -

GTI -

EU -

Scholarships -

START OF THE PROJECT

2011

INFORMATION

HA Dijkstra

H.A.Dijkstra@uu.nl



WHO & WHERE





Mechanical Maritime and Material Engineering (3ME)

Process & Energy (3ME-PE)

Prof.dr.ir. BJ Boersma 015 278 7979 b.j.boersma@tudelft.nl

Fluid Mechanics (3ME-FM)

Prof.dr.ir. J Westerweel 015 278 6887 j.westerweel@tudelft.nl
Prof.dr.ir. B Eckhardt (parttime) 015 278 2904 bruno.eckhardt@physik.uni-marburg.de
Prof.dr.ir. RAWM Henkes (parttime) 015 278 1323 r.a.w.m.henkes@tudelft.nl
Prof.dr.ir. G Ooms (em) 015 278 1176 g.ooms@tudelft.nl
Prof.dr. DJEM Roekaerts 015 278 2470 d.j.e.m.roekaerts@tudelft.nl

Maritime and Transport Technology (3ME-MTT)

Prof.dr.ir. RHM Huijsmans 015 278 3598 r.h.m.huijsmans@tudelft.nl
Prof.dr.ir. C van Rhee 015 278 3973 c.vanrhee@tudelft.nl
Prof.dr.ir. TJC van Terwisga (parttime) 015 278 6860 t.v.terwisga@tudelft.nl

Chemical Engineering (CE)

Transport Phenomena (CE-TP)

Prof.dr.ir. CR Kleijn 015 278 2835 c.r.kleijn@tudelft.nl
Prof.dr. RF Mudde 015 278 2834 r.f.mudde@tudelft.nl
Prof.dr.ir. HEA van den Akker 015 278 5000 h.e.a.vandenakker@tudelft.nl
Prof.dr.ir. S Sundaresan 015 278 5000 sundar@princeton.edu

Product and Process Engineering (CE-PPE)

Prof.dr.ir. MT Kreutzer 015 278 9084 m.t.kreutzer@tudelft.nl
Prof.dr.ir. JR van Ommen 015 278 2133 j.r.vanommen@tudelft.nl

Applied Mathematics (AM)

Numerical Analysis (AM-NA)

Prof.dr.ir. C Vuik 015 278 5530 c.vuik@tudelft.nl

Mathematical Physics (AM-MP)

Prof.dr.ir. AW Heemink 015 278 5813 a.w.heemink@tudelft.nl

Applied Sciences (AS)

Radiation Science and Technology (AS-RST)

Prof.dr.ir. THJJ van der Hagen/Rohde 015 278 2105 t.h.j.j.vanderhagen@tudelft.nl

Aerospace Engineering (AE)

Prof.dr.ir. H Bijl 015 278 5373 h.bijl@tudelft.nl
Prof.dr. F Scarano 015 278 5902 f.scarano@tudelft.nl
Prof.dr. S Hickel 015 278 9570 s.hickel@tudelft.nl

Civil Engineering and Geosciences (CEG)

Fluid Mechanics (CEG-FM)

Prof.dr.ir. WSJ Uijtewaal 015 278 1371 w.s.j.ujtewaal@tudelft.nl
Prof.dr. J Pietrzak 015 278 9455 j.d.pietrzak@tudelft.nl
Prof.dr.ir. AJHM Reniers 015 278 5426 a.j.h.m.reniers@tudelft.nl

Geoscience and Remote Sensing

Prof.dr.ir. AP Siebesma 015 278 4720 a.p.siebesma@tudelft.nl
Prof.dr.ir. HJJ Jonker 015 278 6157 h.j.j.jonker@tudelft.nl

Applied Physics (AP)

Vortex Dynamics and Turbulence (AP-WDY)

Prof.dr. HJH Clercx	040 247 2680	h.j.h.clercx@tue.nl
Prof.dr.ir. GJF van Heijst	040 247 2722	g.j.f.v.heijst@tue.nl
Prof.dr.ir. F Toschi	040 247 3911	f.toschi@tue.nl
Prof.dr.ir. BJ Geurts (parttime)	040 247 4285	b.j.geurts@tue.nl

Mesoscopic Transport Phenomena (AP-MTP)

Prof.dr.ir. AA Darhuber	040 247 4499	a.a.darhuber@tue.nl
Prof.dr. J Harting (parttime)	040 247 3766	j.d.r.Harting@tue.nl
Prof.dr. JH Snoeijer (parttime)	040 247 9111	j.h.snoeijer@tue.nl

Transport in Porous Media (AP-TPM)

Prof.dr.ir. OCG Adan (parttime)	040 247 3398	o.c.g.adan@tue.nl
---------------------------------	--------------	--

Plasma Physics (AP-PP)

Prof.dr.ir. GMW Kroesen	040 247 4357	g.m.w.kroesen@tue.nl
-------------------------	--------------	--

Mechanical Engineering (ME)

Energy Technology (ME-ET)

Prof.dr.ir. EH van Brummelen	040 247 5470	e.h.v.brummelen@tue.nl
Prof.dr.ir. DMJ Smeulders	040 247 2140	d.m.j.smeulders@tue.nl
Prof.dr.ir. AA van Steenhoven	040 247 2132	a.a.v.steenhoven@tue.nl
Prof.dr.ir. CJ van Duijn (em)	040 247 2855	c.j.v.duijn@tue.nl
Prof.dr.ir. HMA Wijshoff (parttime)	040 247 5399	h.m.a.wijshoff@tue.nl
Prof.dr. HA Zondag (parttime)	040 247 2719	h.a.zondag@tue.nl

Multiphase and Reactive Flows (ME-MRF)

Prof.dr.ir. NG Deen	040 247 3681	n.g.deen@tue.nl
Prof.dr. LPH de Goey	040 247 2140	l.p.h.d.goey@tue.nl
Prof.dr. JGM Kuerten	040 247 2362	j.g.m.kuerten@tue.nl
Prof.dr. M Golombok (parttime)	040 247 3664	m.golombok@tue.nl

Microsystems (ME-MS)

Prof.dr.ir. JMJ den Toonder	040 247 2987	j.m.j.d.toonder@tue.nl
-----------------------------	--------------	--

Biomedical Engineering (BE)

Cardiovascular Biomechanics (BE-BVM)

Prof.dr.ir. FN van de Vosse	040 247 4218	f.n.v.d.vosse@tue.nl
-----------------------------	--------------	--

Chemical Engineering and Chemistry (CEC)

Multi-scale Modelling of Multiphase Flows (CET-SMM)

Prof.dr.ir. JAM Kuipers	040 247 4158	j.a.m.kuipers@tue.nl
-------------------------	--------------	--

Chemical Process Intensification (CET-SPI)

Prof.dr.ir. M van Sint Annaland	040 247 2241	m.v.sintannaland@tue.nl
---------------------------------	--------------	--

Mathematics and Computer Science (MCS)

Centre for Analysis, Scientific Computing and Applications (MCS-CASA)

Prof.dr.ir. B Koren	040 247 2080	b.koren@tue.nl
Prof.dr. MA Peletier	040 247 2628	m.a.peletier@tue.nl
Prof.dr. WHA Schilders (parttime)	040 247 5518	w.h.a.schilders@tue.nl
Prof.dr. JJM Slot (parttime)	040 247 4381	j.j.m.slot@tue.nl

University of Twente

Science and Technology (TNW)

Physics of Fluids (PoF)

Prof.dr. D Lohse	053 489 8076	d.lohse@utwente.nl
Prof.dr. D van de Meer	053 489 2387	d.vandermeer@utwente.nl
Prof.dr. J Snoeijer	053 489 3085	j.h.snoeijer@utwente.nl
Prof.dr. M Versluis	053 489 6824	m.versluis@utwente.nl
Prof.dr.ir. JF Dijkman (em)	06 2334 1331	j.f.dijkman@ziggo.nl
Prof.dr. J Harting (parttime)	053 489 4829	j.harting@tue.nl
Prof.dr. A Prosperetti (parttime)	053 489 9111	prosperetti@jhu.edu
Prof.dr. C Sun (parttime)	053 489 9111	c.sun@utwente.nl
Prof.dr. R Verzicco (parttime)	053 489 2470	r.verzicco@utwente.nl
Prof.dr.ir. L van Wijngaarden (em)	053 489 3086	l.vanwijngaarden@tnw.utwente.nl
Prof.dr. X Zhang	053 489 2470	x.zhang-3@utwente.nl

Physics of Complex Fluids (PCF)

Prof.dr. F Mugele	053 489 3094	f.mugele@utwente.nl
-------------------	--------------	---------------------

Chemical Engineering (CT)

Soft Matter, Fluidics and Interfaces (SFI)

Prof.dr.ir. RGH Lammertink	053 489 2063	r.g.h.lammertink@utwente.nl
----------------------------	--------------	-----------------------------

Engineering Technology (CTW)

Engineering Fluid Dynamics (EFD)

Prof.dr.ir. CH Venner	053 489 2488	c.h.venner@utwente.nl
Prof.dr.ir. HWM Hoeijmakers (em)	053 489 4838	h.w.m.hoeijmakers@utwente.nl

Thermal Engineering (TE)

Prof.dr.ir. ThH van der Meer	053 489 2530	t.h.vandermeer@utwente.nl
------------------------------	--------------	---------------------------

Multiscale Mechanics (TSMSM)

Prof.dr. S Luding	053 489 4212	s.luding@ctw.utwente.nl
-------------------	--------------	-------------------------

Water Engineering Management (WEM)

Prof.dr. SJMH Hulscher	053 489 4256	s.j.m.h.hulscher@utwente.nl
------------------------	--------------	-----------------------------

Electrical Engineering, Mathematics and Computer Science (EEMCS)

Applied Analysis (AA)

Prof.dr.ir. EWC van Groesen	053 489 3413	e.w.c.vangroesen@utwente.nl
-----------------------------	--------------	-----------------------------

Mathematics of Computational Science (MACS)

Prof.dr.ir. JWW van der Vegt	053 489 5628	j.j.w.vandervegt@utwente.nl
------------------------------	--------------	-----------------------------

Multiscale Modelling and Simulation (MMS)

Prof.dr.ir. BJ Geurts	053 489 4125	b.j.geurts@utwente.nl
-----------------------	--------------	-----------------------

University of Groningen

Computational Mechanics and Numerical Mathematics (CMNM)

Prof.dr.ir. RWCP Verstappen	050 363 3958	r.w.c.p.verstappen@rug.nl
Prof.dr. AEP Veldman (em)	050 363 3939	veldman@math.rug.nl

Wageningen University

Experimental Zoology (EZ)

Prof.dr.ir. JL van Leeuwen

0317 482267 johan.vanleeuwen@wur.nl

Food Process Engineering (FPE)

Prof.dr.ir. CGPH Schroen

0317 483396 karin.schroen@wur.nl

Utrecht University

Institute for Meteorology and Oceanography (IMAU)

Prof.dr.ir. HA Dijkstra

030 253 5441 h.a.dijkstra@uu.nl

Prof.dr.ir. LRM Maas (parttime)

0222 369 419 maas@nioz.nl

Board of Directors

Prof.dr.ir. CJ van Duijn (TUE, Chairman)	040 247 2855	c.j.v.duijn@tue.nl
Prof.dr.ir. JWM Hilgenkamp (UT)	053 489 2806	j.w.m.hilgenkamp@utwente.nl
Prof.dr.ir. CR Kleijn (TUD)	015 278 2835	c.r.kleijn@tudelft.nl
Prof.dr.ir. GMW Kroesen (TUE)	040 247 4357	g.m.w.kroesen@tue.nl
Ir. JJ Meerman (Teijin Aramid)	088 268 9367	hans.meerman@teijinaramid.com

Management Team

Prof.dr.ir. AA van Steenhoven (TUE)	040 247 2140	a.a.v.steenhoven@tue.nl
Prof.dr. D Lohse (UT)	053 489 8076	d.lohse@utwente.nl
Prof.dr.ir. J Westerweel (TUD)	015 278 6887	j.westerweel@tudelft.nl

Industrial Board

Ir. GJN Alberts (TNO Science & Industry)	088 866 0677	garrelt.alberts@tno.nl
Ir. AJ Dalhuijsen (VSL)	015 269 1500	adalhuijsen@vsl.nl
Ir. G Hommersom (Dow Benelux)	0115 67 4102	ghommersom@dow.com
Dr.ir. J Janssen (Unilever)	010 460 6324	jo.janssen@unilever.com
Ir. J de Jong (DSM)	06 5520 4591	jelle.jong-de@dsm.com
Dr. L Korstanje (STW)	030 600 1300	l.korstanje@stw.nl
Ir. JJ Meerman (Teijin Aramid)	088 268 9367	hans.meerman@teijinaramid.com
Prof.dr.ir. AE Mynett (WL)	015 285 8580	a.mynett@unesco-ihe.org
Dr. J Kok (NLR)	020 511 3020	johan.kok@nlr.nl
Dr.ir. TWJ Peeters (Tatasteel)	0251 495018	tim.peeters@tatasteel.com
Dr. E Pelssers (Philips)	040 291 0926	eduard.pelssers@philips.com
Ir. J Pennekamp (Deltares)	088 335 8273	johan.pennekamp@deltares.nl
Dr.ir. HJ Prins (Marin)	0317 493 405	h.j.prins@marin.nl
Ir. H Reinten (Oce)	077 359 4061	hans.reinten@oce.com
Ir. M Riepen (ASML)	040 268 3000	michel.riepen@asml.nl
Ir. M Roest (VORTECH)	015 285 0127	mark.roest@vortech.nl
Ir. P Veenstra (Shell) (Chairman)	020 630 3384	peter.veenstra@shell.com
Ir. Veraar (TNO Defence and Safety)	015 284 3395	ronald.veraar@tno.nl
Dr.ir. FC Visser (Flowserve)	076 502 8311	fvisser@flowserve.com
Dr.ir. B Vreman (AKZO-Nobel)	026 366 9440	bert.vreman@akzonobel.com
Dr. P de Witte (FOM)	030 600 1211	pieter.de.witte@fom.nl

JM Burgerscentrum (the Netherlands)

Prof.dr.ir. GJF van Heijst, scientific director	015 278 1176	g.j.f.v.heijst@tue.nl
I Hoekstein-Philips, secretariat	015 278 3216	jmburgerscentrum@tudelft.nl
Mekelweg 22628 CD Delft		

Burgers Program Maryland

James M Wallace, Professor, Dept. of Mechanical Engineering

www.eng.umd.edu/~wallace

Gemstone Program Director

www.gemstone.umd.edu/Chair,

Burgers Program for Fluid Dynamics

www.burgers.umd.edu

T 301 314 6695F 301 314 8469

E wallace@eng.umd.edu







JMBC ANNUAL REPORT & RESEARCH PROGRAMME
2015-2016