

2010

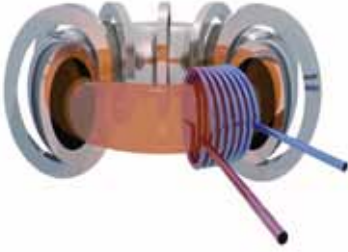

2011

# ANNUAL REPORT & RESEARCH PROGRAMME

J.M.Burgerscentrum 

Research School for Fluid Mechanics  
TUD, TUE, UT, RUG, RUN, UL, WUR, UU



**ANNUAL REPORT & RESEARCH PROGRAMME 2010-2011**

JM Burgerscentrum  
Research School for Fluid Mechanics

TUD, TUE, UT, RUG, RUN, UL, WUR, UU

© May 2011, JM Burgerscentrum

All rights reserved. No part of this publication may be reproduced in any form by print, photoprint, microfilm or any other means without written permission of the rightful claimant(s). This restriction concerns the entire publication or any part of it.

**CORRESPONDENCE FOR REPRODUCTION**

JM Burgerscentrum  
Attn. Mrs. I Hoekstein  
Mekelweg 2  
2628 CD Delft  
The Netherlands  
T 015 278 3216  
F 015 278 2979  
E [jmburgerscentrum@tudelft.nl](mailto:jmburgerscentrum@tudelft.nl)  
[www.jmburgerscentrum.nl](http://www.jmburgerscentrum.nl)

Burgers Program for Fluid Dynamics (University of Maryland, USA)  
[www.enme.umd.edu/burgers/](http://www.enme.umd.edu/burgers/)

Contributions of the participating groups, Industrial Advisory Board and Contactgroups. Final editing : Prof.dr.ir. G Ooms and Mrs. I Hoekstein of the JM Burgerscentrum.

Design and lay-out : I Hoekstein  
Printed by : NIVO, Delft

## PREFACE



Prof.dr.ir. G Lodewijks  
Chairman of the JMBC Board



Prof.dr.ir. G Ooms  
Scientific Director

As in preceding years this annual report of the J.M. Burgerscentrum (JMBC) provides an overview of the activities of our research school during last year (2010) and a plan of action for the current year. The core of the report consists of the description of the research projects, carried out by the JMBC groups. In each report the relevant information (title, theme, staff involved, project aim, achievements, publications, funding source, application, etc.) is given. Also some research highlights are presented. It also provides general information about the research school, such as goals, organization, relation with industries and technological institutes.

Members of JMBC groups were very successful in their work during last year. We give some examples:

- ◆ Prof. Philip de Goey was appointed to Simon Stevin Meester 2010 by the Netherlands Foundation of Applied Sciences on 7 October. It is a great honor for him and his group. It is also a great honor for the JMBC: last year prof. Detlef Lohse and this year prof. Philip de Goey !
- ◆ Prof. Kemo Hanjalic received the Royal Decoration: Officier in de Orde van Oranje-Nassau. It is a recognition of his very important contribution to science and fluid flow in particular.
- ◆ Prof. Jerry Westerweel (together with prof. Ronald Adrian) published the book 'Particle Image Velocimetry'. Although the concept of measuring the fluid velocity by measuring the displacements of particles in the fluid is simple in essence, the factors that need to be addressed to design and implement PIV systems that achieve reliable, accurate and fast measurements are surprisingly numerous. The aim of the book is to analyze and explain them comprehensively.

During the meeting of the Council of Project Leaders of the JMBC on 21 May the new course program of our research school was discussed and composed. In the academic year 2010-2011 there are eight courses. It is important that the PhD-students follow the required number of courses. The details are given in the course booklet and on the JMBC website.

The First Dutch OpenFOAM Day took place at the Delft University of Technology on November 4. OpenFOAM is a C++ toolbox for the customization and extension of numerical solvers for continuum mechanics problems, including computational fluid dynamics (CFD). There is a rapidly growing interest and development of OpenFOAM at universities and industries. It becomes an important platform for smooth and rapid transition of ideas, methods, and software developed at universities to industries and research institutes. Since it is open source all details of the used methods are available. The JMBC sponsored this event.

The Burgersdag 2011 at Delft University of Technology was again a great success. There was a record number (270 !) of participants. The event was opened by dr. Eppo Bruins, the director of the Netherlands Foundation of Applied Sciences. Prof. Andrea Prosperetti (Johns Hopkins University) gave a fascinating Burgers Lecture. Prof. Frans van de Vosse (TU/e) and prof. Harm Jonker (TUD)) presented their work at the end of the day. The largest part of the Burgersdag was devoted to 12 minute-presentations by PhD-students during two parallel sessions. There was again a common session at the end of the day, during which the winner of the best presentation and the best poster was announced.

ERCOFTAC asked the JMBC to organize the ERCOFTAC Spring Festival 2010 at the TU-Delft. ERCOFTAC is the European organization in the area

of fluid mechanics. It has pilot centers in many countries. For The Netherlands the JMBC is the pilot centre. The JMBC organized the festival on 17 and 18 May. During the first day there was a symposium with speakers from academia and industries in the morning. In the afternoon there were visits to the Fluid Mechanics Laboratory of the faculty Aerospace Engineering, the Kramers Laboratory of the faculty Applied Sciences and the Laboratory for Aero and Hydrodynamics of the faculty 3mE. The second day was devoted to the meetings of the IA, PC and Management Board of ERCOFTAC.

Due to the enthusiasm and the combined knowledge, skills and facilities of the participating research groups, the JMBC remains to be a very stimulating, multidisciplinary environment for advanced research in fluid mechanics and for the education of talented graduate and postgraduate students. The board and the management team of the JMBC highly value the large effort of the staff of the JMBC in reaching the goals of the research school.

Prof.dr.ir G Lodewijks

*Chairman of the JMBC-Board*

Prof.dr.ir. G Ooms

*Scientific Director*

# CONTENTS

---







## CONTENTS

### ORGANISATION

13	Introduction
14	Participating universities and groups
16	Industrial Board
17	Contactgroup "Multiphase Flow"
17	Contactgroup "Computational Fluid Dynamics (CFD)"
17	Contactgroup "Combustion"
18	Contactgroup "Lattice-Boltzmann techniques"
19	Contactgroup "Turbulence"
19	Contactgroup "Experimental Techniques"
20	Contactgroup "Biological Fluid Mechanics"
21	Contactgroup "Microfluidics"
21	Burgers Program for Fluid Dynamics at the University of Maryland

### HIGHLIGHTS

25	Table-top rotating turbulence : an experimental insight through PTV Lorenzo Del Castello, Herman Clercx, TU/e
27	Perpendicular ultrasound assessment of blood pressure and flow waveforms in arteries BWAMM Beulen, N Bijnens, AC Verkaik, GG Koutsouridis, MCM Rutten, FN van de Vosse, TU/e
29	Large Eddy Simulation of a curved open-channel flow over topography W van Balen, WSJ Uijttewaai, TUE
31	Local stability of rotating tokamak plasmas JW Haverkort (CWI, Rijnhuizen), HJ de Blank (Rijnhuizen), B Koren (CWI, UL)
33	Doplet breakup in homogeneous and isotropic turbulence F Toschi, TU/e

### RESEARCH

37	Introduction
37	Description of the research themes
39	Focal points in the research programme
42	Review of progress in research projects

### TUD

43	Fluid Mechanics
61	Marine Technology
65	Dredging Engineering
71	Numerical Analysis
83	Mathematical Physics
89	Multi-Scale Physics
125	Physics of Nuclear Reactors

DelftChemTech	129
Aerodynamics	135
Environmental Fluid Mechanics	147
<b>TUE</b>	
Mesoscopic Transport Phenomena	161
Vortex Dynamics and Turbulence	179
Combustion Technology	203
Process Technology	229
Energy Technology	237
Centre for Analysis, Scientific Computing and Applications (CASA)	251
Applied Analysis	259
Cardiovascular Biomechanics	265
Multiphase Reactors Group	271
<b>UT</b>	
Computational Biophysics	287
Physics of Fluids	293
Physics of Complex Fluids	317
Applied Analysis & Mathematical Physics (AAMP)	331
Numerical Analysis and Computational Mechanics	335
Engineering Fluid Dynamics	343
Thermal Engineering	361
Multiscale Mechanics	373
Water Engineering and Management	389
<b>RUG</b>	
Combustion Science and Engineering	397
Computational Mechanics and Numerical Mathematics	401
<b>LU</b>	
Granular and disordered media	409
Mathematical Institute Leiden	413
<b>WUR</b>	
Experimental Zoology Group	419
<b>UU</b>	
Institute for Marine and Atmospheric Research Utrecht (IMAU)	423
<b>WHO AND WHERE</b>	
Participating groups and project leaders	429
JMBC Board of Directors	432
Management Team	432
Industrial Board	432
PhD students Representatives	432
PhD students Contact Group	432
JM Burgerscentrum (The Netherlands)	433
Burgers Program for Fluid Dynamics (University of Maryland, USA)	433

# ORGANISATION

---





## ORGANISATION

The JM Burgerscentrum (JMBC) is the Dutch research school for fluid mechanics. The Delft University of Technology is the coordinating university. The main goals of the JMBC are:

- ♦ Stimulation of co-operation of the participating groups with respect to their research efforts. It is the desire to be one of the leading institutes for fluid mechanics in the world.
- ♦ Organization of advanced courses for PhD-students. Researchers from industries and technological institutes also attend these courses.
- ♦ Co-operation with industries and technological institutes. The aim is to promote the use of up-to-date knowledge on fluid mechanics for solving practical problems.
- ♦ Strengthen the contacts between Dutch fluid mechanics research groups at universities and the international fluid mechanics community.

About 60 professors with their groups participate in the JMBC. These groups are located at the Delft University of Technology, Eindhoven University of Technology, University of Twente, the University of Groningen, Leiden University, Wageningen University and Utrecht University. They are from a number of disciplines; such as Civil Engineering; Mechanical Engineering; Maritime Technology; (Applied) Physics; Aerospace Engineering; Applied Mathematics and Chemical Technology. The professors with their senior staff form the council of project leaders, which meets regularly. There are about 250 PhD-students in the JMBC.

The JMBC has a scientific director who is responsible for the management of the research school; the JMBC secretary assists him. Three times per year he justifies his actions to the Board of the JMBC, and asks the Board for advice with respect to proposed new activities. He is also assisted by the Management Team, which consists of the local directors from the Delft University of Technology (also responsible for the groups at the University of Leiden), Eindhoven University of Technology (also responsible for the groups at the University of Wageningen and Utrecht University) and the University of Twente (also responsible for the groups at the University of Groningen).

The research projects carried out by the JMBC-groups have been ordered in a number of research themes. The reason for this ordering is to present in each theme a combination of projects which have coherence. The themes are:

- ♦ Complex dynamics of fluids
- ♦ Complex structures of fluids
- ♦ Mathematical and computational methods for fluid flow analysis.

The JM Burgerscentrum has many good contacts with industries and technological institutes in The Netherlands. For that reason there is an Industrial Board, in which Unilever, TataSteel, Philips, AKZO-Nobel, Teijin Aramid, Shell, DOW Benelux, ASML, DSM, Océ, NLR, NMI/VSL, TNO-Science and Industry, TNO-Defence and Safety, TNO-Oil - and Energy Industry, MARIN, Deltares, KEMA, ESTEC, ECN/NRG and FlowServe participate. The Industrial Board meets twice per year with the scientific director to discuss new activities of relevance to industries and technological institutes.

Each year (also in 2010) there are many scientific contacts with research groups in other countries. For that reason there are often external visitors to the JMBC groups. JMBC staff also regularly visits foreign fluid-mechanics groups, and presents their work at international conferences. The number of publications from JMBC staff in well-known scientific journals is considerable.

Together with Engineering Mechanics (the research school on solid mechanics) the JMBC forms the Centre for Fluid Solid Mechanics. This Centre has been recognized as a centre of excellence in The Netherlands and has received significant funding by the Dutch Government for stimulating new research areas in fluid and solid mechanics.

The JMBC has attracted top-experts in different fields of fluid mechanics to the JMBC. These experts have been appointed as JMBC-professors or Centre-of-Excellence professor at the three Technological Universities and are financed by the Boards of the Technological Universities or by the Centre for Fluid and Solid Mechanics. They contribute considerably to the achievements of the research school. An important activity of the JMBC is the organisation of the annual meeting of the research school (Burgersdag). This year about 270 persons attended the meeting. The theme of the meeting was research by JMBC PhD-students.

#### OVERVIEW OF THE CONTRIBUTION OF THE PARTICIPATING GROUPS OF THE JMBC

University and (sub)faculty	Project leaders	Scientific staff (fte)	Support staff (fte)	PhD students (fte)
<b>TUD</b>				
Mechanical Engineering	J Westerweel, JCR Hunt,	6.2	2.0	13.6
	G Ooms, B Eckhardt			
Marine Technology	BJ Boersma	1.0	-	8.0
	RHM Huijsmans,	1.0	0.3	4.8
	TJC van Terwisga			
Applied Mathem. Analysis	C van Rhee	-	-	-
	C Vuik, P Wesseling	3.0	-	5.6
Multi-Scale Physics	AWH Heemink	1.9	-	2.4
	HEA van den Akker,	13.0	7.8	22.6
	S Sundaresan, AP Siebesma,			
HJJ Jonker, CR Kleijn, RF Mudde,				
Physics of Nuclear Reactors	RAWM Henkes, DJEM Roekaerts			
DelftChemTech	THJJ van der Hagen	1.1	-	2.0
Aerospace Engineering	M-O Coppens	1.9	0.5	2.4
Civil Eng. & Geosciences	H Bijl, F Scarano, PG Bakker	6	2	13
	GS Stelling, WSJ Uijtewaal	6.5	-	11.2
<b>TUE</b>				
Applied Physics	AA Darhuber, F Toschi,	2.1	3.0	12.0
	MEH van Dongen			
	GJ van Heijst, H Kelder,			
Mechanical Engineering	HJH Clercx, BJ Geurts	4.2	1.1	8.0
	LPH de Goey, RSG Baert	4.4	2.0	10.6
	LEM Aldén			
	JJH Brouwers	1.2	-	4.8
Mathematics and Computer Science	AA van Steenhoven, AH Dietzel	2.1	1.8	10.0
	HA Zondag			
Biomedical Engineering	RMM Mattheij, F Toschi	2.5	0.5	2.4
	CJ van Duijn, JJM Slot	2.3	-	1.6
Multiphase Reactors Group	FN van de Vosse	0.8	-	3.2
	JAM Kuipers, M van Sint Annaland	2.0	1.8	10.8

University and (sub)faculty	Project leaders	Scientific staff (fte)	Support staff (fte)	PhD students (fte)
<b>UT</b>				
Applied Physics	WJ Briels	2.4	-	5.6
	D Lohse, A Prosperetti, L van Wijngaarden, R Verzicco	8.0	3.3	14.6
	F Mugele	6.4	2.2	8.8
Mathematical Sciences	EWC van Groesen	0.9	-	1.6
	JJW van der Vegt, HJH Clercx, BJ Geurts	5.7	-	8.0
	HWM Hoeijmakers, A Hirschberg	2.0	-	7.0
Mechanical Engineering	ThH van der Meer	0.8	0.4	4.0
	S Luding	2.4	-	2.4
	SJM Hulscher	5.3	-	13.6
Water Engineering & Manag.				
<b>RUG</b>				
Chemistry	HB Levinsky	0.9	-	2.4
Mathematics	AEP Veldman	1.5	-	4.8
<b>RUN</b>				
Applied Molecular Physics	JJ ter Meulen, W van de Water	2.4	1	3.2
<b>UL</b>				
Mathem. and Natural Sciences	M van Hecke	1.7	-	-
Mathematical Institute	B Koren	0.2	-	4.0
<b>WUR</b>				
Biometris	J Molenaar	0.2	-	0.8
Experimental Zoology Group	JL van Leeuwen	0.5	-	0.8
<b>UU</b>				
Physics and Astronomy	LRM Maas	0.2	-	0.8

The calculation of fte's is based on:

Professor 0,4 fte | Associated professor and assistant professor 0,5 fte | post-doc 1,0 fte | PhD-student 0,8 fte

#### OVERVIEW OF UNIVERSITY PARTICIPANTS

University	Scientific staff (fte)	Support staff (fte)	PhD-students (fte)
TUD	38.6	12.6	85.6
TUE	21.6	10.2	63.4
UT	33.9	5.9	65.6
RUG	2.4	-	7.2
RUN	2.4	1.0	3.2
UL	1.9	-	4.0
WUR	0.7	-	1.6
UU	0.2	-	0.8
Total	101.7	29.7	231.4

The actual number of PhD students during 2010 was approx. 250

## INDUSTRIAL BOARD

For the last time I will have the privilege to write a few introductory words for the Annual Report of the J.M. Burgers Center, the research school for fluid dynamics in The Netherlands. I have been a member of the Industrial Advisory Board of the J.M. Burgers center from the very beginning as a research school "avant la lettre". The reputation of the center has grown immensely, nationally and internationally. Also the numbers of PhD students at the different universities have increased from year to year. The environment of the J.M. Burgers center has been changed gradually over time as well. Within a time frame of 15 to 20 years the financing of the universities has been changed from a matter of course to a struggle for life, in the meantime a number of large companies in the Netherlands closed their corporate research laboratories. As holds true for the same big companies, the Dutch universities have to focus. For academia that means that they have to take their responsibility to society and have to find answers to the main issues of today, such as sustainability, climate change, healthy environment, rising of the sea level, growing population, spread of wealth, efficient use of energy, alternative energy sources, food production, transport, clean water supply for everybody. I am confident that the J.M. Burgers Center will contribute to the quest for a better world as fluid dynamics, ranging from large scale turbulence of earth atmosphere to micro fluid dynamics embedded in diagnostic medical devices, from detailed experimental work to the use of parallel computing, will be key for solving the problem areas mentioned.

From this place I would like to complement all scientists that have contributed to the present Annual Report. The activities in the JM Burgers Centrum are presented in a coherent way, as well as in the other issues of the J.M. Burgers center such as the Research Program, the Course Program and the JMBC Newsletter. In that way the JMBC presents itself as the main organization on fluid dynamics in the Netherlands. Know that your Annual Report will be on many desks in and outside the universities. It will serve as a look-up document to see what is going on in your organization and it will definitely generate new contacts and maybe also new research initiatives. The Burgers day of 2010 organized at the University of Twente was again a great event, giving a podium to PhD students to show their results either during an oral presentation or during poster sessions.

In the Industrial Advisory Board/Program Committee are represented: Unilever, TataSteel, Philips, AKZO-Nobel, Teijin Aramid, Shell, DOW Benelux, ASML, DSM, Océ, NLR, NMI/VSL, TNO-Science and Industry, TNO-Defence and Safety, TNO-Oil - and Energy Industry, MARIN, Deltares, KEMA, ESTEC, ECN/NRG and FlowServe. The names and addresses of the representatives of these companies in the Board are listed in the who and where section of this report. Especially, I would like to encourage PhD-students but also the permanent staff to take the opportunity to contact one of us when information about one of the participating companies is needed, e.g. when applying for a job or to look for support for a new research initiative.

Last but not least, I would like to respectfully recognize the work of the bureau of the JMBC, Professor Gijs Ooms and Mrs. Ilse Hoekstein-Philips for the professional and careful issuing of the official documents and organizing the events of the research school.



Dr.ir. JF Dijkman  
Philips Research Laboratories  
Eindhoven  
Chairman of the Industrial Advisory Board



Prof.dr.ir. AE Mynett  
Deltares & UNESCO-IHE  
Chairman of the Industrial Advisory Board



Dr. RPJ Duursma  
Tatasteel  
Successor of JF Dijkman





Prof.dr.ir. RAWM Henkes  
Delft University of Technology



Dr.ir. NG Deens  
Eindhoven University of Technology



Prof.dr.ir. AEP Veldman  
University of Groningen



Prof.dr. DJEM Roekaerts  
Delft University of Technology

### **CONTACTGROUP “MULTIPHASE FLOW”**

The objective of the Contactgroup Multiphase Flow is to stimulate interaction and collaboration between researchers, developers, and users in the area of multiphase flow from universities, institutes and industries. This is done through organizing regular meetings (once or twice per year) aimed at getting to know each other's activities and to learn about developments and applications of multiphase flow technology. This will provide a good forum to identify the needs of the users and to bring to the attention new possibilities for applying multiphase flow research results. Industry, a research institute or a university in turn act as host of the meetings. The program consists of a series of lectures on a specific theme and a visit of some of the local multiphase flow facilities. Examples of themes covered are: dynamic multiphase flows, multiphase flows with surface-active agents, multiphase flow measurements and innovation with multiphase flow. On 20th May 2010 a one-day meeting was held at TNO, jointly organized with the Contactgroup Computational Fluid Dynamics. The theme of that day was “CFD for Multiphase Flows”.

### **CONTACTGROUP “COMPUTATIONAL FLUID DYNAMICS (CFD)”**

The purpose of the contactgroup CFD is to give CFD-researchers and users of CFD in universities, laboratories and industries in The Netherlands and Belgium the opportunity to get to know each other and to get acquainted with each other's work.

### **CONTACTGROUP COMBUSTION**

The JMBC has groups active in combustion research at the universities of Delft, Eindhoven, Groningen, Nijmegen and Twente. The contactgroup combustion is an informal network between these groups. The groups play an important role in the organisation of the symposia of the Dutch section of the Combustion Institute, which is part of the international Combustion Institute, an international forum for scientific combustion research. These groups also have formed the STW-platform 'Clean and Efficient Combustion' to enhance the mutual collaboration between the different groups and to interest more industrial parties for the fundamental research on combustion.

In September 2010 the Combustion Course of the JM Burgers Centre took place. Lectures were given by professors and staff members of the Burgers Centre groups and by guest professors M. Aldén (University Lund and TU/e) and P.J. Coelho (Technical University Lisbon).

The COMBURA symposium was organised for the 9th time. It took place in Maastricht on October 12 and 13. This symposium is the major annual event in The Netherlands for exchange of information on combustion research and its applications. It is a joint initiative of the Technology Foundation STW, the Nederlandse Vlam Vereniging NVV (Dutch section of the International Flame Research Foundation IFRF) and the Dutch section of the Combustion Institute.

The first day was devoted to the eight research projects within the STW program on Clean Combustion Concepts (CCC), all of which are executed by research groups of the JM Burgers Centre. A central theme of the second day was fuel flexibility, an important issue with the introduction of biofuels in industrial processes.

Since January 2011 professor Hans ter Meulen, head of the combustion diagnostics group at Radboud University Nijmegen is emeritus. He gave his valedictory address title “Geen toepassing zonder fundament” at a symposium in Nijmegen on October 29, 2010.

#### **CONTACTGROUP “LATTICE-BOLTZMANN TECHNIQUES”**

The contactgroup “Lattice-Boltzmann techniques” was established in 2002. It has initiated the JMBC course “Particle-based modeling”. The lattice-Boltzmann research in the Netherlands covers a broad spectrum of applications. To mention a few: flow and scalar transport in porous media, biological flows, suspension dynamics, chemically reacting flows, turbulent flows. Lattice-Boltzmann schemes are part of the family of particle-based simulation techniques. In the lattice-Boltzmann method, (fictitious) particles move and collide on a regular lattice. With the proper collision rules and lattice topology, such a system mimics the dynamics of a real fluid. The power of the method lies in the geometrical flexibility, in the locality of its computational operations (intrinsic parallelism), and in the intuitive way in which multicomponent fluids can be represented.



Prof.dr. F Toschi  
Eindhoven University of Technology



Prof.dr.ir. BJ Boersma  
Delft University of Technology



Prof.dr.ir. J Westerweel  
Delft University of Technology



Dr. M Versluis  
University of Twente

#### **CONTACTGROUP “TURBULENCE”**

The objective of the contactgroup turbulence is to organize meetings between researchers of the J.M. Burgers Centre active in the field of turbulence. The purpose of these meetings is give the AIO/OIO's and other university researchers the opportunity to present their research results in an informal atmosphere and at the same time to promote a discussion on these results. The meetings also strengthen the contact between the researchers of the J.M. Burgers Centre and allows exchange of results and experience. The next Turbulence Course will be held in 2011..

#### **CONTACTGROUP “EXPERIMENTAL TECHNIQUES”**

The Contact Group Experimental Techniques forms a platform where experiments and experimental techniques can be discussed and evaluated. The main function of the contact group is to organize meetings in which the practice of experimenting can be discussed. An important contribution of the contact group is the organization of the JMBC course on Experimental Techniques in Fluid Mechanics. The course is very popular among the JMBC members as it gives a broad overview of advanced experimental techniques commonly used in fluid mechanics laboratories. The next course will be held 26-29 April 2010 at the University of Twente.

### CONTACTGROUP “BIOLOGICAL FLUID MECHANICS”

More and more research is conducted at the border between biology and fluid mechanics. This happens within many disciplines, from physiology (e.g. the interaction between blood flow and vessel walls) to aerodynamics (e.g. flapping flight). However, all deal with the interaction between fluids and a complex, changing geometry. One of the main challenges is to bridge the gaps between physics (esp. fluid mechanics) and medical and health sciences. To stimulate this relatively young field of research and bring together researchers, a new contact group was started in 2006. While the contactgroup is formally a part of the J.M. Burgerscentrum, the participation from researchers from non-affiliated universities, medical centers and institutes is encouraged. Recent activities include mini-symposia in Wageningen (Experimental Zoology Group) and Eindhoven (in combination with the JMBC course on Bio-fluid Mechanics).

The Bio-Fluid Mechanics course (March 2009: about 40 participants) was jointly supported by the JM Burgers Centre and the ERCOFTAC organization by advertising the course amongst their members, via the website and by some financial means. Topics included: a recap of basics of fluid mechanics, external flows (swimming and flying, interaction of plankton and turbulence), internal flows (microcirculation, hemodynamics in large arteries, flow in flexible tubes, respiratory system, etc.). Examples of relevant experimental techniques, as well as simulation techniques were discussed.

Finally, members of the contactgroup are active in the definition of a new FOM-program in the bio-fluid mechanics field.



Prof.dr.ir. AA van Steenhoven  
Eindhoven University of Technology



Dr.ir. C Poelma  
Delft University of Technology



Prof.dr. F Mugele  
University of Twente



Prof.dr. J den Toonder  
Philips Research  
Eindhoven University of Technology



Prof.dr.ir. J Westerweel  
Delft University of Technology



Prof.dr. JM Wallace  
University of Maryland

#### **CONTACT GROUP “MICROFLUIDICS”**

The contact group “Microfluidics” was established in 2005 with a first meeting in Delft. The purpose of the contact group is to bring together students and postdocs interested in fluid dynamic aspects of microfluidics and give them a regular forum for presenting their results and exchanging ideas.

Topics of interest include wetting and capillarity-driven flows, two-phase flow, drop generation and emulsification, contact line dynamics, flow visualization and measurement techniques. In April 2009, contact group members organized the first JMBC course “Capillarity-driven flows in microfluidics”. Furthermore, as special session “Microfluidics, wetting, and thin film flows” at the joint FOM-JMBC-industry meeting “Changing Flows” in June 2009.

The course Capillarity and wetting was held in 2011.

#### **BURGERS PROGRAM FOR FLUID DYNAMICS AT THE UNIVERSITY OF MARYLAND**

Inspired by the intellectual heritage of J.M. Burgers, the mission of the Burgers Program for Fluid Dynamics at the University of Maryland is to enhance the quality and international visibility of the research and educational programs in fluid dynamics and related areas at the University of Maryland in partnership with the J.M. Burgerscentrum (JMBC) in The Netherlands. Fluid dynamics in this context is viewed to include a broad range of dynamics, from nanoscales to geophysical scales, in simple and complex fluids. The establishment of the Burgers Program for Fluid Dynamics was celebrated with an inaugural symposium at the University of Maryland in November 2004. At the second Burgers Symposium James Wallace gave a talk commemorating the legacy of Frans T. M. Nieuwstadt. The interdisciplinary Burgers Program encompasses over 70 faculty members spread over 22 different units in the College of Computer, Mathematical and Physical Sciences, the College of Chemical and Life Sciences and the A. James Clark School of Engineering. For detailed information go to <http://www.burgers.umd.edu/>.

Burgers Visiting Faculty and Student Exchanges - In 2003 the Burgers Program created a Burgers Visiting Professorship in fluid dynamics. We have been able to attract distinguished professors from universities abroad to spend up to a year at the University of Maryland working with our faculty and their graduate students. The first Burgers Visiting Professor was Bruno Eckhardt, Professor of Theoretical Physics from Phillips Universität in Marburg, Germany. He spent the 2004-2005 academic year with us. In 2005-2006 we enjoyed the visits of two Burgers Associate Professors: Dr. Sasa Kenjeres of J. M. Burgers Center in the Netherlands and Dr. Serge Simoëns of the Ecole Centrale de Lyon in France. In May 2007 Prof. Jerry Westerweel, Director of the Laboratory for Aero and Hydrodynamics of Delft University of Technology was our Burgers Visiting Professor for three months. In the spring of 2008 Prof. Willem van de Water of the Eindhoven University of Technology visited our Program to work with Prof. Wolfgang Losert of our Physics Dept. for 2 ½ months. In addition, several graduate students from JMBC have had visits of several months at Maryland. Faculty from the University of Maryland are encouraged to spend a sabbatical at one of the Dutch Universities associated with JMBC. For instance, Kenneth Kiger, who was a speaker at the Burgersdag 2006, earlier had spent a sabbatical year with the JMBC research group in Delft. Prof. Wim Briels was visiting professor at Maryland at 2010.

Burgers Lectureship - We have also initiated an annual Burgers Lecture which is given by a distinguished visitor who comes to the campus for several days or even weeks in November. This is always the keynote lecture at our annual Burgers Symposium, which takes place in the week before the annual Division of Fluid Dynamics meeting of the American Physical Society. In 2003 Prof. Frans Nieuwstadt, then Director of the Laboratory for Aero and Hydrodynamics of Delft University of Technology, was our lecturer. Since then, Prof. Bruno Eckhardt, Prof. Charles Meneveau of Johns Hopkins University, Prof. Gijs Ooms, Chairman of the Burgers Center in the Netherlands, Prof. Detlef Lohse of Twente University, Prof. Wim van Saarloos of Leiden and Prof. Kees Vuik of Delft have been our Burgers Lecturers.

Annual Graduate Student/Post-doctoral Fellow Showcase with Johns Hopkins University - In collaboration with the Center for Applied and Environmental Fluid Mechanics of Johns Hopkins University, the Burgers Program has put on an annual graduate student/post-doctoral fellow showcase symposium in the spring of each year, beginning in April, 2005. The venue for the symposium alternates between sites each year. After a keynote address by a faculty member from the visiting institution, students and research associates give short presentations on their research. Members of the fluid dynamics community from around the region are invited to attend the symposium with the hope that the presentations will interest these attendees and create employment opportunities for the presenters.

Tutorial School on Fluid Dynamics - This new initiative will be inaugurated in late May 2010, with plans to offer it every year. The subject of the first School is Turbulence. The level of instructions is aimed a level beyond that of a first graduate course in the subject area. Almost 40 graduate student and post-doc participants from the U.S. and other countries, including nine from JMBC, will attend.

Fluid Dynamics Reviews seminars - This seminar series, which has continued for over forty years at the University of Maryland, has been incorporated into the Burgers Program. It is supported by the Minta Martin research fund. The format allows for faculty and their students and post-docs from the Burgers Program as well as for visitors to give presentations five or six times per semester. The seminar series has sponsored the visits of a long list of very distinguished speakers over the many years it has been a part of the campus' intellectual life.

# HIGHLIGHTS

---

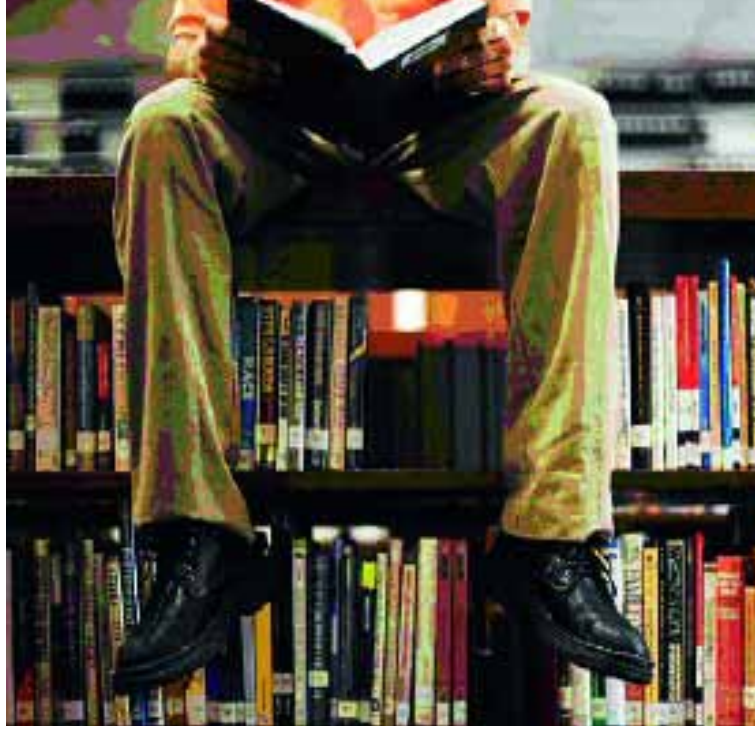





## TABLE-TOP ROTATING TURBULENCE : AN EXPERIMENTAL INSIGHT THROUGH PTV

Lorenzo Del Castello and Herman Clercx, Dept. Applied Physics, TU/e

The influence of the rotation of the Earth on oceanic and atmospheric currents, as well as the effects of a rapid rotation on the flow inside industrial machineries like mixers, turbines, and compressors, are only the most typical examples of fluid flows affected by rotation. Despite the Coriolis acceleration term appears in the Navier-Stokes equations with a straightforward transformation of coordinates from the inertial system to the rotating non-inertial one, the physical mechanisms of the Coriolis acceleration are subtle and not fully understood. Several fluid flows affected by rotation have been studied by means of numerical simulations and analytical models, but the experimental data available is scarce and purely of Eulerian nature. Here we focus on a class of fluid flows of utmost importance: confined and continuously forced rotating turbulence.

Experimental set-up mounted on the rotating table.

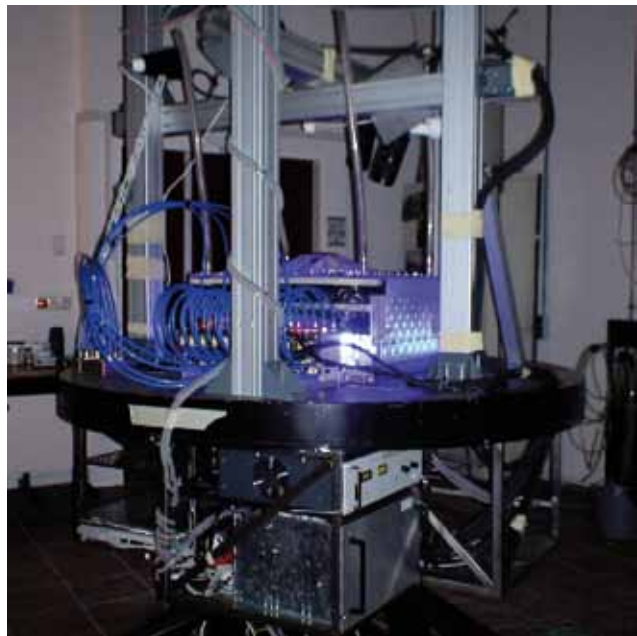

Experiments of the turbulent flow (maximum  $Re_\lambda \approx 110$  for  $\Omega = 0$  rad/s) subjected to different background rotation rates (with  $\Omega$  in the range of zero to five rad/s) are performed, visualised by optical means, and measured quantitatively by means of Particle Tracking Velocimetry (PTV). The measurement system is designed and implemented around the experimental set-up (see Fig. 1), using several innovative solutions. The data collected is processed in the Lagrangian frame, where the trajectories are filtered and the 3D time-dependent signals of position, velocity, acceleration, temporal velocity derivatives, and full velocity gradient tensor are extracted. The data is further interpolated over a regular grid, in order to analyse it also in the Eulerian frame.

The rotating turbulent flow is investigated in terms of Eulerian spatial correlations of the velocity field, and – for the first time – of Lagrangian correlations of the velocity, acceleration, and vorticity vectors extracted along fluid particle trajectories. The increase of vertical (parallel to the rotation vector) and horizontal velocity correlations induced by rotation is measured in the Eulerian and the Lagrangian frames. The vertical and horizontal Lagrangian integral time scale against the rotation rate  $\Omega$  behaves remarkably different (see Fig. 2). Moreover, rotation is seen to strongly enhance the correlation of the vertical vorticity component, characteristic of a flow dominated by columnar vortex structures. It is also seen to enhance the longitudinal horizontal acceleration correlation, confirming the direct role of the Coriolis acceleration in the amplification of the Lagrangian acceleration correlations in turbulence.

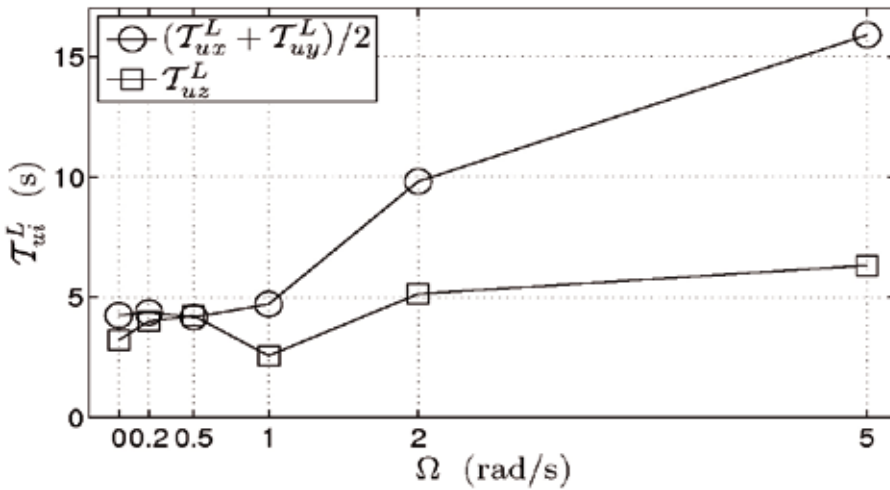

Horizontal and vertical Lagrangian integral time scale against the rotation rate  $\Omega$ .

## PERPENDICULAR ULTRASOUND ASSESSMENT OF BLOOD PRESSURE AND FLOW WAVEFORMS IN ARTERIES

BWAMM Beulen, N Bijnens, AC Verkaik, GG Koutsouridis, MCM Rutten, FN van de Vosse (TUE)

Vascular impedance, defined as the transfer function between blood pressure and blood flow at a certain location in an artery, characterizes the properties of the vascular bed downstream and is of particular value in studies on heart load, vascular circulation and distal vascular bed vasomotricity. Studies of arterial impedance in humans, however, are hampered by the lack of reliable non-invasive techniques to simultaneously record volume flow and pressure waveforms locally as a function of time. Local pressure assessment together with flow assessment in arteries, therefore, has great potential for improving the ability to diagnose and monitor cardiovascular disease.

Classical Doppler ultrasound allows an accurate assessment of the component of the blood velocity along the ultrasound beam. To assess the axial blood velocity component, the ultrasound beam has to be positioned at a known angle with respect to the blood vessel. To relate the velocity measurement to volume flow, however, assumptions have to be made on the axial velocity distribution across the vessel since most arteries are tapered, curved and bifurcating, causing the axial velocity distribution to be altered by transversal velocities.

In addition, the position of the vessel walls needs to be known in order to perform the integration from velocity to flow. The position of the vessel walls, however, can only be assessed accurately with the ultrasound beam in perpendicular orientation with respect to the vessel. This renders a simultaneous measurement of velocity by Doppler ultrasound and wall position impossible, hampering an accurate flow assessment.

Recently we developed an ultrasound velocity assessment technique similar to PIV, which focuses on the assessment of the velocity component perpendicular to the ultrasound beam. This permits a simultaneous assessment of axial velocity profile and vessel wall position, thereby enabling an accurate assessment of volume flow and facilitating simultaneous pressure estimation.

The validation (see Figure 1) is performed in an experimental setup, in which physiological flows are generated using a fluid, which mimics both the acoustic and rheological properties of blood [1,2].

The experimental setup to validate the ultrasound pressure and flow assessment (left). The perpendicular configuration of the ultrasound array probe (middle). The measured velocity profile obtained from PIV data analysis on the raw RF signal (right).

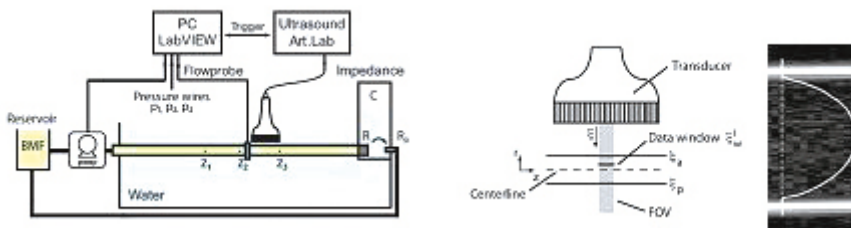

Velocity profile measurements are performed by applying PIV-based analysis techniques to raw RF-data acquired with a commercially available, clinically approved ultrasound system, equipped with a linear array transducer. Resulting velocity profiles are compared to analytical and computational fluid dynamics calculations [3]. Finally, the velocity profiles are integrated to volume flow and compared to reference flow measurements (see figure 2, left).

Additionally, due to the applied perpendicular insonification of the ultrasound beam, the vessel diameter changes can be accurately assessed simultaneously from the same measurement. The local pulse wave velocity in the artery can be estimated during a reflection free period of the cardiac cycle as the ratio between the change in flow and the change in cross-sectional area [4]. The reflection free period can be identified as a linear section in the flow-area-loop. The pulse wave velocity is related to the compliance by the well-known Moens-Korteweg relation from which follows that once known, local pulse pressure waveforms can be estimated from the distension waveforms (see figure 2, right).

In conclusion, the combination of flow and cross-sectional area was found to allow an accurate and precise estimation of the pulse wave velocity. Based on this an accurate beat to beat local pressure waveform could be obtained, indicating that a noninvasive pressure assessment by means of ultrasound is feasible. The introduced method enables an improved assessment of the condition of the vascular system, which can be applied to identify parameters that are characteristic for the development of cardiovascular disease and to monitor the effect of therapeutic interventions.

## REFERENCES

1. Beulen, B.W.A.M.M., Bijmens, N., Rutten, M.C.M., Brands, P.J. and van de Vosse, F.N., 2010, "Perpendicular ultrasound velocity measurement by 2D cross correlation of RF data. Part A: validation in a straight tube", *Exp Fluids*, 49, pp. 1177-1186.
2. Beulen, B.W.A.M.M., Verkaik, A.C., Bijmens, N., Rutten, M.C.M. and van de Vosse, F.N., 2010, "Perpendicular Ultrasound Velocity Measurement by 2D Cross Correlation of RF Data. Part B: volume flow estimation in curved vessels", *Exp Fluids*, 49, pp. 1219-1229.
3. Verkaik AC, Beulen BWAMM, Rutten MCM, Bogaerds ACB, van de Vosse FN. Estimation of volume flow in curved tubes based on analytical and computational analysis of axial velocity profiles. *Physics of fluids*. 2009;21(2):023602–1/13.
4. Beulen, B.W.A.M.M., Bijmens, N., Koutsouridis, G.G., Brands, P.J, Rutten, M.C.M. and van de Vosse, F.N., 2010, "Towards non-invasive blood pressure assessment in arteries by using ultrasound", *Ultrasound in Med. & Biol.*, Accepted.

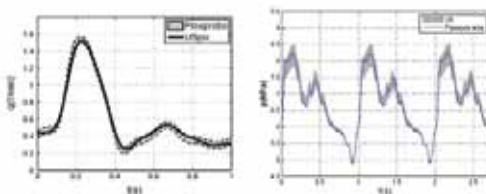

Perpendicular ultrasound flow (solid line) against flow measured with a flow probe (left). Perpendicular ultrasound pressure against pressure measured with a pressure wire (right).

W van Balen, WSJ Uijttewaal (TUD)

Most rivers have the natural tendency to follow a winding course in their alluvial plane. This shape is the result of centrifugal forces in the turbulent flow in combination with erodible banks and bed. It is therefore important to understand how the shear stresses at the boundaries are distributed and to what extent they are related to the general features of the bend, like curvature, depth to width ratio and bed roughness. To that end Large-eddy flow simulations (LES) are performed of a curved open-channel flow over topography based on a laboratory experiment. In the experiment, the large-scale bed topography had developed to a more or less stationary shape which was prescribed in the LES model as boundary conditions neglecting the small-scale dune forms by means of a straightforward immersed boundary scheme in combination with a simple wall-modeling approach [1]. The small-scale dunes are accounted for in the numerical model by means of a parametrization of the roughness. The sensitivity of the flow to this roughness parametrization is examined by simulating the flow for three different roughness heights. It was found that, notwithstanding the coarse method of representing the dune forms, the qualitative agreement of the experimental results and the LES results is rather good. Comparison of the LES results with the Reynolds averaged numerical simulation results reveals surprisingly good agreement. This good agreement is explained by the minor importance of turbulence stress gradients in the contribution to the transverse and streamwise momentum balance. Moreover, it is found that in the bend the structure of the Reynolds stress tensor shows a tendency toward isotropy which enhances the performance of isotropic eddy viscosity closure models of turbulence.

This observation is remarkable since highly anisotropic turbulence might well be expected considering the complex nature of the geometry. Furthermore, the LES results reveal a pronounced recirculation zone near the convex inner bank of the flume due to the shallowness of the flow and strong curvature of the flume. At the interface between the recirculation zone and the main flow, a curved mixing layer is identified as well as strong upwelling flow motion that is accompanied with large production of turbulent kinetic energy.

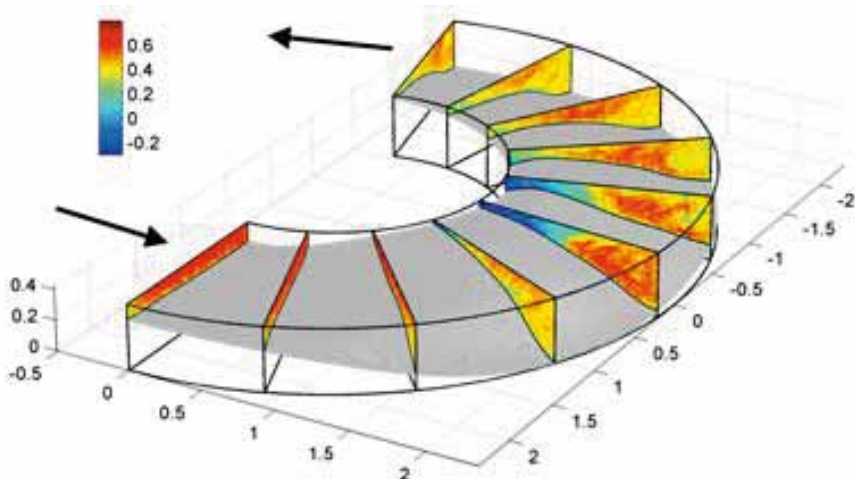

Earlier work on more schematized geometries with a flat bed revealed that turbulence anisotropy contributes to the formation and strength of the secondary circulation cells, disqualifying e.g.  $k-\epsilon$  as a turbulence model for those cases [2,3]. Apparently the highly schematized geometries put higher demands on the turbulence modeling whereas nature is merciful in this respect by providing a more complex geometry yet a simpler flow.

## REFERENCES

1. van Balen, W., Uijttewaai, WSJ, and Blanckaert K. (2010) "Large-eddy simulation of a curved open channel flow over topography" *Physics of Fluids* 22, 075108, doi:10.1063/1.3459152
2. van Balen, W. , Blanckaert, K. and Uijttewaai, WSJ (2010) 'Analysis of the role of turbulence in curved open-channel flow at different water depths by means of experiments, LES and RANS', *Journal of Turbulence*, 11, N 12, doi: 10.1080/14685241003789404
3. van Balen, W., Uijttewaai, WSJ, and Blanckaert K (2009) "Large-eddy simulation of a mildly curved open-channel flow" *J. Fluid Mech.* 630, pp. 413–442, doi:10.1017/S0022112009007277.

JW Haverkort (CWI, Rijnhuizen), HJ de Blank (Rijnhuizen) and B Koren (CWI, UL)

The most widely investigated design for a controlled nuclear fusion reactor for the production of energy, is that of the tokamak. This toroidal device (see figure) magnetically confines a hot ( $10^8$  K) deuterium-tritium plasma. Present tokamaks often show toroidal plasma rotation approaching the sound speed. Such rotation can significantly influence the stability of the hot plasma, which can be described quite well with the theory of magnetohydrodynamics (MHD).

Using various simplifications, the MHD equations can be reduced to an inhomogeneous Sturm-Liouville type of differential equation [1]. We approached the question of marginal stability by investigating under which conditions solutions to this equation exist that neither oscillate nor grow. We linearized the angular rotation frequency  $\Omega$  around a radial position  $r$  where the stabilizing influence of the magnetic field is smallest. Thereby we restricted the analysis to instabilities of limited spatial extent, excluding various spatially more extended instabilities. For subsonic flow, with  $\omega_A$  the Alfvén frequency, the resulting stability criterion may be written as [2]

$$\underbrace{\frac{r}{4} \left( \frac{q'}{q} \right)^2}_{\text{Static plasmas [3, 4, 5]}} > \underbrace{-\beta' (1 - q^2)}_{\text{Kelvin-Helmholtz}} + \underbrace{\frac{q^2}{\omega_A^2} \left( \frac{1 + 2q^2}{4q^2} r \Omega'^2 \right)}_{\text{MRE + convective}} - \underbrace{\frac{\rho \Omega'^2 + \Omega^2 \rho'}{\rho}}_{\text{Brunt-Väisälä}} - \underbrace{\frac{\omega_{EV}^2}{r}}_{\text{Brunt-Väisälä}} + \underbrace{2\Omega'^2 r'}_{\text{flutter}}$$

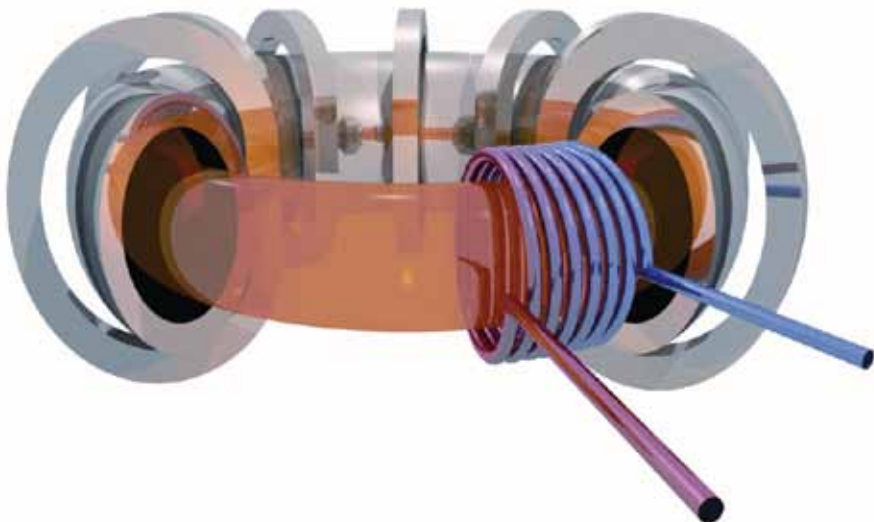

The first part of this stability criterion concerns static plasmas and dates back to the 1960s [3, 4, 5]. It states that the variation in the pitch  $q$  of the magnetic field and the magnetic field curvature  $-\beta'q^2$  should be large enough to overcome the destabilizing pressure gradient  $-\beta'$ . The positive first term in between brackets represents the destabilizing Kelvin-Helmholtz effect of flow shear  $\Omega'$ . The second term is typically destabilizing, because the kinetic energy density generally decreases radially in a tokamak plasma. This term can be decomposed into two terms that represent the magnetorotational instability (MRI) and the incompressible convective instability, respectively. The MRI plays a role in the turbulent transport of accretion disks.

The convective instability is well known from the atmosphere, which becomes unstable when the specific entropy decreases with height or otherwise facilitates stable oscillations with a Brunt-Väisälä (BV) frequency  $\omega_{BV}$ . Here, the centrifugal force plays the role of gravity. The large magnetic pressure renders plasma motion perpendicular to the magnetic surfaces approximately incompressible, while motion within the magnetic surfaces can compress freely. This is why both the compressible ( $\omega_{BV}^2$ ) and incompressible ( $r\Omega^2\rho'/\rho$ ) BV-frequencies appear. The final term in the stability criterion is typically stabilizing and is associated with the fluttering motion of the plasma flow past the instability.

Although limited in its generality, the derived stability criterion provides great insight into the various rotational effects and provides quantitative information about their magnitude. The net influence of rotation can be stabilizing or destabilizing, depending crucially on the particular profiles of the angular frequency  $\Omega$  and density  $\rho$ .

## REFERENCES

1. C. Wahlberg. Plasma Phys. Contr. Fusion, vol. 51 (2009), 085006
2. J. W. Haverkort and H. J. de Blank. Plasma Phys. Contr. Fusion, vol. 53 (2011), 045008.
3. C. Mercier. Nucl. Fusion, vol. 1 (1960), pp. 47–53
4. A. A. Ware and F. A. Haas. Phys. Fluids, vol. 9 (1966), pp. 956–964
5. V. D. Shafranov and E. I. Yurchenko. Sov. Phys. JETP, vol. 26 (1968), pp. 682–686.



F Toschi, TU/e

Turbulent emulsions are key to many natural and industrial processes alike. In presence of an external flow, droplets undergo deformation, breakup and coagulation. In a turbulent flow, breakup of droplets larger than the Kolmogorov scale is influenced by the interplay between surface tension and turbulent fluctuations. The ratio of the two forces can be expressed in terms of the Weber number

$$We(d) = \frac{\rho d u_d^2}{\sigma}$$

where  $d$  is the droplet diameter, the velocity difference is estimated on the size of the droplet diameter and surface tension,  $\sigma$ , and density of the fluid,  $\rho$ , are also involved. The maximum droplet diameter that does not undergo breakup was estimate by Hinze as:

$$d_{max} = 0.75 \left( \frac{\rho}{\sigma} \right)^{-3/5} \varepsilon^{-2/5}$$

We study the breakup of droplets in a stationary homogeneous and isotropic flow. We consider droplets with the same density of the transporting fluid. The droplets and the fluid are numerically modeled by means of a multicomponent Lattice-Boltzmann method. The turbulent fluid is sustained through a large scale stirring force. Parameters were chosen to keep the radius of stable droplets larger than the Kolmogorov scale while the interface thickness was kept smaller than the Kolmogorov scale. Panels in figure 1 shows droplet deformation and break-up at different times during the simulation. At dilute droplet concentrations we could verify the Kolmogorov-Hinze criteria as well as measure the full probability distribution function of droplets radii in the statistically stationary phase.

The three snapshots show how an initially spherical droplet deforms and breaks when turbulence is switched on.



**REFERENCES**

1. F. Toschi, P. Perlekar, L. Biferale, and M. Sbragaglia, Droplet breakup in homogeneous and isotropic turbulence, arXiv:1010.1795.

The plot shows the time evolution of the droplet count in a turbulent flow. The inset shows representative droplets configuration at different times.

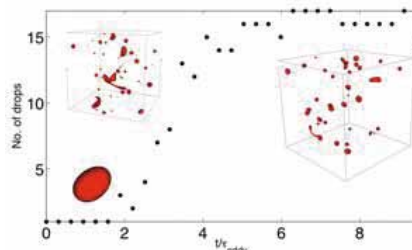



# RESEARCH

---

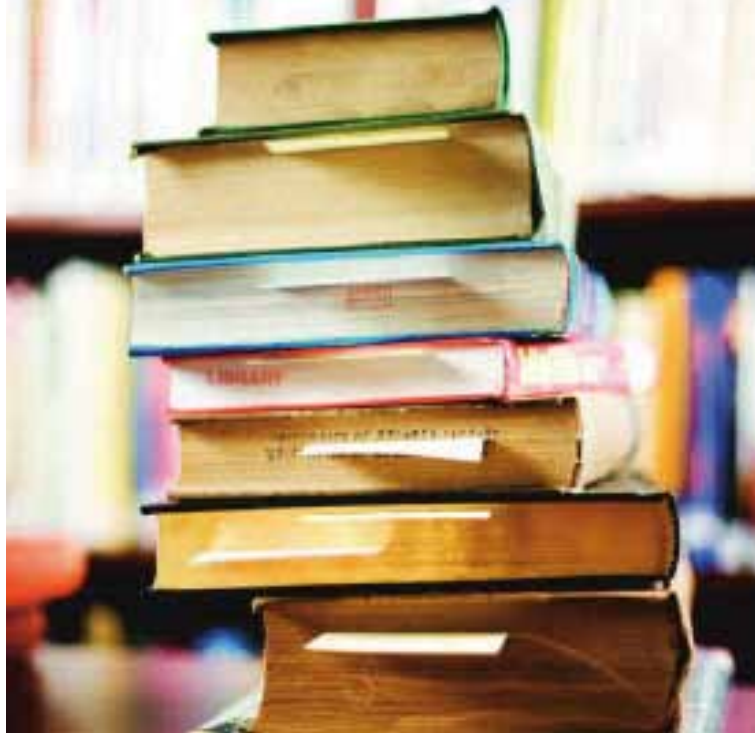



## RESEARCH

### INTRODUCTION

The research programme of the JMBC has been ordered in research themes and focal points. The reason for this ordering is to present a combination of projects which have coherence, either in terms of physical models or in terms of mathematical methods.

The main themes are:

1. Complex dynamics of fluids
2. Complex structures of fluids
3. Mathematical and computational methods for fluid flow analysis

### DESCRIPTION OF THE RESEARCH THEMES

#### 1. COMPLEX DYNAMICS OF FLUIDS

Fluid flows in the environment or in industrial applications are almost always characterised by some form of complexity. Frequently it is this complexity that makes the flow an interesting topic of research. Below we will sketch several examples of such flows and flow phenomena which form research topics carried out in the various groups of the J.M. Burgerscentrum.

The first form of complex dynamics which comes to mind is turbulence in contrast to a laminar flow. Here complexity appears in the form of strong non-linearity. Due to its chaotic behaviour turbulence can be considered as the archetype of a complex flow, and - being far from solved - turbulence will remain a strong focal point of research in the coming period. Turbulence research traditionally addresses the following questions:

- ♦ what are the physical processes and interactions governing turbulence,
- ♦ how can they be quantified and described mathematically,
- ♦ how to predict turbulence and turbulent flow for particular configurations, and
- ♦ how to control and manipulate turbulence?

Future research in this field in particular will focus on laminar-to-turbulent and reverse transition, effects of thermal buoyancy, unsteadiness, compressibility and rotation, and on the interaction with chemical reactions. The role of turbulence in energy conversion processes and equipment are regarded as an intriguing field of applications.

Complexity may also appear in the form of a combined flow of various phases. When these phases are immiscible, phenomena such as free surface flows occur. These may appear in the form of various wave phenomena, for instance on an unobstructed water surface, but also in a confined geometry of a pipe.

Another type of such flow of immiscible phases is when one of the phases is distributed in the form of small particles, bubbles or droplets in the other continuous phase. Various combinations of phases may be selected and each has its own particular problems. This class of flows, generally denoted as dispersed multi-phase flow, at the moment forms a strong focal point of research within the JMBC. The combination of phases that are miscible leads to other interesting problems such as mixing, and - depending on the fluids that take part in the mixing - chemical reactions or combustion.

Finally, complexity of the flow can also appear through its boundary conditions. For instance the flow geometry can strongly influence the flow characteristics by means of straining, shearing and distortion. An example is the wake behind a body in a shearing or straining flow.

Furthermore, the exact formulation of boundary conditions can have a consequence for the type of flow characteristics that appear.

An example is the free convection above a flat surface with a variable the conductivity. Geometry constraints on the flow are also dominant also when one considers a flow in 2D versus 3D. Here one should take as an example the quite different characteristics of 2D turbulence versus 3D-turbulence.

An increasingly important JMBC research activity within Theme 1 is aero-acoustics, aimed at the identification and quantification of acoustic sound sources in internal and external flows. Such sources can be related to unsteady vortex shedding, turbulence, combustion and flow-structure interaction. In general there is a strongly non-linear mutual interaction between sound source and acoustic field. The applications and technical implications show a great diversity. The JMBC is actively involved in vortex sounds in ducts, musical instruments (like the flute and the organ pipe), human speech, acoustics in burner stabilized flames, sound generation by turbulent flames, with much attention to analytical and numerical modelling of these flows.

The flow cases mentioned above, which are by no means an exhaustive list of complex fluid flow phenomena, form research topics in the various groups in the J.M. Burgers Centre.

The tools to carry out this research are primarily numerical and experimental. The numerical techniques used to compute flow phenomena are direct and large eddy numerical simulation, turbulence modelling and computational fluid dynamics. The experimental techniques used nowadays are mostly based on various forms of laser diagnostics (e.g. like PIV and PTV for flow measurements and CARS, LIF and Cavity Ring-Down Spectroscopy for temperatures and concentrations). Experiments, simulations and analytical theories in the field of fluid flow analysis complement each other - perhaps more than in other branches of physics. Future research will inevitably make use and take advantage of combined techniques and their complementing roles. Both the research topics themselves and the research techniques to carry out these investigations, form the basis of a strong collaboration within the J.M. Burgerscentrum.

## 2. COMPLEX STRUCTURES OF FLUIDS

Research in this Theme deals with complex structures of flow, formed in the presence of particles, drops, or bubbles, i.e., two- or even multi-phase flow. Two-phase flow is of paramount importance in contemporary science and technology.

One can readily cite a multitude of examples: the production and transport of oil (where bubbles are purposely injected to help lift thick heavy oil to the surface, or arise due to the release of dissolved gases), energy generation (where boiling is the key process in producing the steam to drive turbines), the chemical industry (where gas-liquid reactors rely on bubbles to increase the contact area between the phases), the oceans (where breaking-wave generated bubbles are important sinks for atmospheric CO<sub>2</sub>), sedimentation (where sinking sand particles determine the structure of our coasts), food-industry, and many others.

The challenge in single-phase flow is to understand the complicated dynamics which is generated by the Navier-Stokes equation. In two-phase flow, even the underlying dynamical equations are often not known. E.g., it is not understood why bubbles repel each other when they are close to each other.

But even when the microscopic interactions are known, it is often not clear how the macroscopic structure evolves from this microscopic interaction and the response to external forces.

In many cases instabilities are involved in the macroscopic structure formation process. Very complex self-organising patterns can evolve out of these instabilities. An important example is cluster formation in sedimentating particles and coherent structures in bubble columns and fluidised beds.

Related topics are flow-controlled nucleation and droplet growth processes in high-pressure natural gas, which have important technical applications in the natural gas industry. Different JMBC groups are involved in the design of new types of condensate separators and in the numerical description of swirling supersonic two-phase flows, while a dedicated facility has been developed in order to investigate these condensation processes in a well-defined way experimentally.

How to theoretically describe such a complex system? Two types of approaches have been described in literature: In the first type of approach, the particles/bubbles/drops are treated essentially as points, while no attempt is made to simulate their detailed response to the liquid dynamics.

The advantage of this approach is that many particles/bubbles/drops can be treated, but the price to be paid is a lot of ad-hoc modelling. Fluid dynamical simulations in which the particles/bubbles/drops are modelled through averaged equations also belong to this first type of approach. In the second type of approach the detailed interactions of the particles/bubbles/drops with the flow is simulated, paying the price that - at present - the surrounding flow can not really be turbulent

and that only “a few” objects can be treated, in particular, when the interfaces are allowed to deform, i.e., for free boundary problems (drops and bubbles).

One of the main objectives for the research in two-phase flow must be to bridge the gap between these two types of approaches and to carry out a detailed investigation of the interaction between one or a few particles/bubbles/ drops and a nontrivial flow field. Another objective must be to better understand the macroscopic structure formation process out of the microscopic interactions, and thus the instabilities in two-phase flow. It is evident that these objectives can only be achieved through a joint experimental, theoretical, and numerical approach.

On the experimental side, the challenge has always been to monitor and document as much information on the dynamics of the flow field as possible. Through the huge advances in both digital imaging techniques and information technology (see Research Theme 3), the field is now flourishing, and the research on two-phase flow will strongly benefit from this. The same is to be expected from the advances with numerical techniques (see Research Theme 4), as brute force numerics will not be sufficient to address the problem of structure formation in two-phase flow. New algorithms and techniques are required and moving toward parallel computing will be essential.

### **3. MATHEMATICAL AND COMPUTATIONAL METHODS FOR FLUID FLOW ANALYSIS**

Advanced mathematical and computational techniques have become indispensable instruments for the description and understanding of complicated flow phenomena. This approach to fluid mechanics has evolved into a full-fledged counterpart to the experimental approach and provides new insight in complex flow physics, in for instance turbulence, combustion, multi-phase and rheological flows.

The use of computational flow models is supported with analytical techniques, which provide deeper insight in canonical flow problems, and strongly interacts with advanced experimental techniques, which are capable of measuring and visualizing complex three-dimensional unsteady flow fields. These techniques require advanced post-processing of the flow field data to understand the flow dynamics and have developed into a research subject in itself. Here tools from non-linear dynamical systems theory can be useful, as well as the decomposition of flow data through POD and wavelet analysis.

The rapid increase in computational power has significantly stimulated the use of computational techniques in flow analysis, but the development of better algorithms has been the most important source for improved numerical techniques for flow analysis.

Many flows are, however, simply too complex for computational techniques and flow modelling remains an essential issue. Compromises have to be found between the inaccuracies in flow modelling and computational constraints. In areas such as turbulent flow simulation much progress has been made through refined modelling via Large-Eddy Simulation (LES) and Direct Numerical Simulation (DNS). There is also an interest for stochastic methods, such as the use of the Langevin equation for the velocity. In the other areas the same trends have become feasible, e.g. PDF modelling in combustion and Brownian Dynamics in rheology.

It can be foreseen that the improvements in numerical algorithms and the growing computational power will open up new applications of flow analysis in other disciplines, such as chemistry, biomedicine and structural mechanics, and will continue to grow in importance. This will be stimulated by the development of new numerical techniques which can efficiently capture flow structures with large differences in length and time scales, the continuous increase in computing power, and by exploiting computational fluid dynamics in multi-physics applications.

### **FOCAL POINTS IN THE RESEARCH PROGRAMME**

Four “focal points” have been selected from the three research themes, which receive special attention. A brief description of these “focal points” is given below.

#### **1. BIO FLUID MECHANICS**

Most biological organisms live in a flowing medium (air or water). Nature has found solutions for fluid mechanical problems which enable fish to swim fast or cellular organisms to propel. These solutions are intriguing to understand and may lead to new solutions for technical problems. Similarly, fluid flow is essential inside the human body, where the blood is pumped around and the air is inhaled.

Deposition of aerosols in the lung, sound production by speaking, atherosclerotic plaque formation at well determined positions, gene activation at cellular levels are all more or less determined by fluid mechanic processes.

Finally, diagnostic and therapeutic techniques make use of fluid mechanic and heat transfer insights. The development of heart valves and the monitoring of temperatures inside the body during operations are examples for that.

Although most of the above mentioned problems can be solved with known physical principles, the complicated geometrical structures and the combination of phenomena (for example the transitional flow of non-Newtonian media in elastic bifurcating channels like blood vessels and airways) form an exciting new area for the development of advanced numerical and experimental techniques. Due to the geometry, three-dimensional unstructured meshes are to be used and the most efficient solvers are required to solve the flow at the relevant dimensionless parameters. Micro-PIV systems are needed to analyse the flow field in micro-vessels and fast optical techniques will enlighten the perfusion in permeable tissues.

New physical insights are needed for several areas, especially in multidisciplinary science. Some examples are given: The combination of fluid mechanics and solid mechanics is apparent in the phenomena at the focal folds where the unsteady flow separation is strongly influenced by the complex movement of the structure. Many modern uses of micro-bubble ultrasound contrast agents rely on the highly nonlinear response of the bubbles to a driving ultrasonic field and a quantitative model is lacking. The heat transfer processes in the anaesthetized body are strongly determined by control mechanisms that are only globally known. Drag reduction occurs at the skin of several fish and reverse transition from turbulent to laminar flow is present in the nasal cavity and stenotic blood vessels; the relation with the wall structure is unclear.

Fluid mechanical parameters stimulate the activation of genes in cells, with striking downstream effects - unexplained. The interaction between the non Newtonian mucus layer in the airways and the oscillating airflow during cough is undescribed. The settlement and growth of settlements in aquatic ecosystems require the combination of advanced flow and mass transport models. As we have noted, research on this topic is extremely diverse and complex, because it involves a large number of different areas of expertise and advanced techniques. Therefore, this theme is an excellent area for collaboration between research groups inside and outside the fluid-mechanics community.

## 2. GRANULAR MATTER

Granular matter exhibits many fascinating phenomena and is attractive both from a fundamental and an applied point of view. Its economic potential is enormous: it has been estimated that no less than 40 percent of the capacity of the industries that process granular matter is wasted due to problems connected to the handling of these materials.

Depending on the situation, granular matter can behave similar to a solid, a liquid, or a gas. E.g., when dry sand is poured, it acts as a fluid. The pile on which it is poured is solid-like, stabilised by forces in between the sand beads. These forces organise themselves in tree-like networks. Finally, when dry sand is strongly shaken or fluidized through a gas stream, it behaves gas-like.

The transition from one to the other regime can be very sudden and the dynamics of such a transition is very rich. When in a gas-like or fluid-like state, the granular particles can all the locally sudden cluster. In many applications this can lead to serious problems, as whole production lines get stuck or the free available surface of some heterogenous catalysator all the sudden gets to small. So it is crucial to better understand the transition to the clustered state in order to avoid it.

The origin of the potential to cluster lies in the inelasticity of the particle-particle collision: If two particles collide, they loose kinetic energy and will thus stay closer to each other, trapping even further particles in the developing cluster.

Even without the phase transitions granular dynamics is difficult to understand. For the fluidised phase the brute-force approach is molecular dynamical simulations, based on some interaction potential between the particles. If this potential is chosen realistically (i.e., rather hard), the time step of advancing the numerical simulation can only be extremely slow, making this approach inpracticable. Better results have been obtained with either (unrealistically) soft potentials or with event driven codes. The ultimate goal must be to achieve at some continuum description, similar to the Navier-Stokes equation for fluid dynamics. Though considerable success in this direction has meanwhile been achieved, the problem is far from being solved. One of the main questions is how to pick the boundary conditions for such a continuum field.

One of the current physical questions one wants to answer is: How do average velocity profiles and velocity fluctuations look like in granular flow? On the experimental side, tomographical methods have turned out to be very successful to reveal these questions. Another intriguing problem of granular dynamics is size segregation. The most famous example presumably is the so called "Brazil nut" effect: In vibro-fluidised granular material big particles tend to "swim" to the top. Two explanations compete. The original interpretation was that the smaller particles can easier fall into gaps which the big ones are leaving when jumping up.



In this way the big particles would be pushed towards the top. The second explanation is based on convection roles and channels which would form, which are too small for the big particles to dive down again, so that they must stay on the top. Both of these interpretations are challenged by the recent discovery of an inverse Brazil nut effect which pushes big particles to the bottom.

Finally, we would like to mention the interaction of granular matter ("sand") with water, which often leads to pattern formation, e.g., the famous sand ripples on the beach. On a larger scale, this interaction is crucial (in particular for the Netherlands) for the protection of the coastline.

### 3. MEASUREMENT TECHNIQUES

Optical diagnostics become more important for the investigation of flows. The principal differences with conventional methods, such as hot-wire anemometry, is that these optical methods can be considered as non-intrusive and that they provide data on the instantaneous spatial structure of the flow field. These optical methods can be divided into two categories: one in which the flow information is extracted from tracer particles added to the fluid (seeded flows), and one in which the fluid information is extracted from the fluid itself (spectroscopic methods).

#### Seeded flows

The motion of the flow can be detected by adding to the fluid very small tracer particles that are small enough to consider the method as non-intrusive. Essentially the motion is recorded by measuring the displacement of the tracers between recordings taken with a small time delay. These methods are collectively known as particle image velocimetry, or PIV. In its most basic implementation, the fluid motion is recorded in a planar cross section of the flow, yielding between 103 and 105 velocity vectors per image, with a precision better than 1%. By using stereoscopic recording, it is possible to measure all three velocity components in a plane. This can now be considered as a standard configuration that can be applied for a broad range of applications, ranging from creeping flows to transonic flows.

The challenge in the near future is to further extend the capabilities of these methods:

- Combination of PIV methods with other (optical) diagnostics makes it possible to determine more complex flow properties. For example, the combination of PIV with measurements of the concentration field or temperature field makes it possible to directly measure scalar flux and heat flux;
- Currently under development is a PIV method that can be used for the investigation of two-phase flow, in which one fluid (viz., liquid) is seeded with tracer particles, and the second fluid (viz., bubbles, droplets, or solid particles) is observed simultaneously. Here the challenge is to obtain measurements in a flow system with very strong optical aberrations due to the second phase;
- One major challenge is to be able to measure the full three-dimensional flow field.

Within the JMBC a photogrammetric technique is developed and applied to various flow problems, and a 3D holographic recording method for PIV is under development.

#### Spectroscopic methods

The development of laser diagnostic techniques is essential for detailed non-intrusive studies of physical and chemical processes in reactive and non-reactive gas flows. At the University of Nijmegen various sensitive detection techniques have been developed and applied to different systems, such as laminar flames, optically accessible diesel engines and non-reactive turbulent flows. Most of these techniques are molecule specific, such as Laser Induced Fluorescence (LIF) detection, Cavity Ring Down Spectroscopy (CRDS) or Raman scattering, which allows for the determination of molecular concentrations. By the application of optical imaging techniques using CCD camera's two-dimensional density distributions can be determined with high spatial and temporal resolution.

The obtained data are used to validate numerical model calculations, which are being performed by other collaborating JMBC groups. For the study of non-reactive flows both Rayleigh and Raman scattering is applied to characterise the density distribution close to boundaries, whereas filtered Rayleigh scattering and Molecular Tagging Velocimetry (MTV) are used for nonseeding velocity measurements. Recently a new promising MTV technique has been developed at Nijmegen, Air Photolysis And Recombination Tracking (APART), which can be used also at high pressure (at least up to 40 bar) to measure velocities with very high spatial resolution. This latter technique is applied for the study of turbulence in collaboration with the groups of Nieuwstadt and Van de Water.

In the near future these laser techniques will be further improved and applied to both combustion and non-reactive flow research. At the University of Groningen LIF, CARS, infrared Cavity Ringdown Spectroscopy and spontaneous Raman scattering are being used for quantitative characterisation of the physics and chemistry of combustion processes, specifically pollutant formation and ignition processes, at atmospheric and reduced pressure.

#### **4. ADVANCED NUMERICAL TECHNIQUES**

An essential tool in studying flow problems is computational fluid dynamics (CFD). CFD is a collective term for a large number of numerical techniques, often each with its own area of application. The last decades have shown a growing knowledge of the fundamental concepts of CFD, and the efficiency of numerical algorithms has progressed at a considerable pace. It is foreseen that this growth will continue for some time.

Although much emphasis is on turbulent flows at high Reynolds number and multi-phase or reacting flows (which are posing the more challenging problems from a physical point of view), insights in simpler problems may be equally useful and often even essential for constructing stable and efficient methods, to be used in more general contexts. Of the latter kind one should mention basic progress in iterative methods and in discretisation approaches. Iterative developments have shown widespread use of multigrid methods and special fast solvers for large linear systems. Combination with implicit time-integration can deal with the issue of stiffness in e.g. reacting flow.

Discretisation methods are challenged by complex geometries and moving boundaries, and by large ranges of length- and time scales. Within the JMBC both Cartesian and unstructured (adaptive) grid approaches are being pursued to deal with the geometric and topological challenges. The (structured) Cartesian grid approach is combined with local grid refinement based on defect correction. The scale resolution problem is tackled e.g. by symmetry-preserving finitevolume methods (with a benign behaviour on underresolved flow features) and by space-time discontinuous finite-element methods (offering flexible spatial and temporal grid adaptation). Also unified algorithms for low-Mach number flow are under development. Further, following a different discretisation philosophy, Lattice-Boltzmann methods are being studied, which possess potential advantages in multi-phase flow simulation. Another important tool in enabling the computations to be performed in a 'reasonably limited' time is parallelisation. Besides a more straightforward use of multiprocessors where the parallelism is taken care of by the compiler, a variety of domain decomposition techniques is in development. In particular within a context where different flow modelling is used in the individual subdomains, research will open up interesting applications, e.g. in turbulent flow simulation where a mixture of RaNS, LES and/or DNS modelling can be envisaged.

#### **REVIEW OF PROGRESS IN RESEARCH PROJECTS**

As agreed by the project leaders of the JMBC only doctoral thesis, (contributions to) books, and publications in scientific journals and in proceedings of conferences with a referee system, are given in the output for each project. Only 2009 publications are taken up in the project descriptions.

An important output for various JMBC-groups is in the form of special reports for industries, technological institutes, etc. Those reports are not mentioned in the output of the projects. For more information, please contact the relevant project leaders. A list of all the projects can be found at the end of this book.

## FLUID MECHANICS



Prof.dr.ir. J Westerweel



Prof.dr.ir. BJ Boersma



Prof.dr. JCR Hunt



Prof.dr.ir. G Ooms



Prof.dr.ir. B Eckhardt

The group of prof. J Westerweel in the section fluid mechanics consist of the following collaborators: prof.dr.ir. BJ Boersma, dr. R Delfos, prof.dr. JCR Hunt, prof.dr.ir. G Ooms, dr. R Lindken, dr.ir. C Poelma, and dr.ir. MJBM Pourquie. The common theme of the research in this group is turbulence and complex flows, such as multiphase flows, microfluidics and biological flows. The research is aimed at fundamental aspects of flows, but always with a clear connection to a practical application or process in industry. This research is carried out by modern experimental methods, such as particle image velocimetry, and by modern numerical methods, such as direct numerical simulation and large-eddy simulation. In most research experimental and numerical methods are combined.

The turbulence research aims at the interaction of turbulence with other processes, such as mixing and chemical reactions, dispersion of small particles, entrainment, aeroacoustics, and polymer drag reduction. A purely fundamental investigation is the transition to turbulence in a pipe flow. Multiphase flows include liquid/liquid dispersions, the interaction between particles and bubbles in a turbulent liquid, and drag reduction in bubbly flow. An example of a three-phase flow is to investigate the use of gas bubbles to capture small particles in a turbulent liquid. This fundamental investigation is related to a mixing and purification process in steel production. About half of the group is active in the area of (multiphase) microscale flows, i.e. microfluidics. This includes investigation of separation methods and (rapid) mixing in microfluidic devices. Mixing is investigated using various geometries, external forces (e.g., electroosmotic flow and acoustic forcing) and actuators. Recently a new stereoscopic micro-PIV system was developed and applied to the investigation of three-dimensional microfluidic flows. Other activities include the development of liquid/liquid microreactors for sample treatment and detection of DNA.

More recent we began to investigate microscale cardiovascular flows. The aim is to investigate the relation between differentiation and adaptation of tissues to fluid mechanical forces. This provides fundamental knowledge to understand the mechanisms of certain diseases, such as atherosclerosis. This research is carried out in close collaboration with medical groups at the universities of Leiden and Rotterdam.

**PROJECT AIM**

Investigate the instabilities occurring in contraction flows of viscoelastic liquids in general and liquid crystalline polymer solutions in specific. Such contraction flows are relevant in many industrial extrusion processes, such as fiber spinning. Ultimately, the instabilities should be controlled, leading to increased process efficiency.

**PROGRESS**

Contraction flows were visualized in production and lab scale fiber spin packs and in microfluidics chips. In all cases, a strong influence was observed of the proximity of neighboring contractions. Moreover, in the microfluidics chips, pre-deformation of the flow, upstream of the contraction, was found to influence the entrance vortex dynamics. In a lab-scale spinning set-up, the diameter profiles of three filaments were measured using digital holography.

**DISSERTATIONS**

-

**SCIENTIFIC PUBLICATIONS**

1. N. V. Semin, C. Poelma, S. Drost and J. Westerweel. Application of digital holography to filament size analysis. Measurement Science and Technology 21, 2010.

**PROJECTLEADERS**

J Westerweel, BJ Boersma,  
G Ooms, JCR Hunt, B Eckhardt

**RESEARCHTHEME**

Complex dynamics of fluids

**PARTICIPANTS**

S Drost, DA Dros, AK Sankaran,  
J Westerweel, SJ Picken,  
MT Kreuzer

**COOPERATIONS**

-

**FUNDED**

AgentschapNL/Senter Novem	
Teijin-Aramid	
University	-
FOM	-
STW	-
NWO Other	-
Industry	100%
TNO	-
GTI	-
EU	-
Scholarships	-

**START OF THE PROJECT**

2009

**INFORMATION**

S Drost  
088 268 9333  
sita.drost@teijinaramid.com

**PROJECT LEADERS**

J Westerweel, BJ Boersma,  
G Ooms, JCR Hunt, B Eckhardt

**RESEARCH THEME**

Complex dynamics of fluids

**PARTICIPANTS**

MJZ Franken, C Poelma,  
J Westerweel

**COOPERATIONS**

ASML, UT, TU/e

**FUNDED**

ASML  
University -  
FOM -  
STW -  
NWO Other -  
Industry 100%  
TNO -  
GTI -  
EU -  
Scholarships -

**START OF THE PROJECT**

2008

**INFORMATION**

MJZ Franken  
015 278 2861  
m.j.z.franken@tudelft.nl  
www.ahd.tudelft.nl

**PROJECT AIM**

The aim of the project is to visualize and understand the behavior of a contact line at a nanoscale. A measurement method is to be developed in order to measure the interface of a droplet at a nanoscale. The method should allow static and dynamic contact angles as well as droplet coalescence to be studied under varying conditions. Experiments will give insight in the way contact line instabilities occur and how these can be prevented.

**PROGRESS**

A measurement method based on TIRFM is developed in order to study nanoscale contact line dynamics. A combined TIRFM-AFM setup is operational for performing the fluorescence measurements, as well as the validation by non-disturbing AFM-imaging of a droplet.

**DISSERTATIONS**

-

**SCIENTIFIC PUBLICATIONS**

1. M.J.Z. Franken, C.Poelma and J. Westerweel. Nanoscale contact line visualization based on total internal reflection fluorescence microscopy. ISFV14 – 14th International Symposium on Flow Visualization, June 21-24, 2010, EXCO Daegu, Korea.

### PROJECT AIM

Friction of water is a large contributor to the total drag in water sports. Reducing this drag leads to higher velocities, which is all about in most water sports; Going faster! The friction can be reduced by changing the surface properties, due to coatings, which will influence the interaction between water and object. The project aim is to develop, characterize and testing specific coatings which will reduce this friction drag.

### PROGRESS

The first year contained the start-up of this PhD-project, as the introduction of the Taylor-Couette and working with this testing facility. The first results of commercial products are determined, as well as the start-up of new developed coatings.

### DISSERTATIONS

-

### SCIENTIFIC PUBLICATIONS

-

### PROJECTLEADERS

J Westerweel, BJ Boersma,  
G Ooms, JCR Hunt, B Eckhardt

### RESEARCHTHEME

Complex dynamics of fluids

### PARTICIPANTS

A Greidanus, R Delfos,  
J Westerweel, S Picken

### COOPERATIONS

InnoSportNL, DSM, TNO, MARiN

### FUNDED

InnoSportNL, DSM	
University	25%
FOM	-
STW	-
NWO Other	25%
Industry	50%
TNO	-
GTI	-
EU	-
Scholarships	-

### START OF THE PROJECT

2010

### INFORMATION

A Greidanus  
015 278 2904  
A.J.Greidanus@tudelft.nl  
www.ahd.tudelft.nl

**PROJECT LEADERS**

TJC van Terwisga, J Westerweel,  
BJ Boersma, G Ooms, JCR Hunt,  
B Eckhardt

**RESEARCH THEME**

Complex dynamics of fluids

**PARTICIPANTS**

O Sverkhovskiy, D van Gils,  
M Harleman, TJC van Terwisga,  
J Westerweel, D Lohse, R Delfos

**COOPERATIONS**

TUD, UT, PPG Industries, MARIN

**FUNDED**

STW, PPG, MARIN	
University	-
FOM	-
STW	87%
NWO Other	-
Industry	13%
TNO	-
GTI	-
EU	-
Scholarships	-

**START OF THE PROJECT**

2007

**INFORMATION**

T van Terwisga  
015 278 6860  
T.J.C.vanTerwisga@tudelft.nl

**PROJECT AIM**

The aim of this project is to enhance the effects of air lubrication on frictional drag significantly, by improving our knowledge on the detailed mechanisms and its scale effects. With this knowledge the effectiveness of air lubrication should be increased in order to make application on ships feasible.

**PROGRESS**

Bubble concentration profiles are measured in low Reynolds number, fully developed, horizontal, turbulent channel flow with shadowgraphy. They are compared to profiles obtained by numerical simulations of channel flow with langrangian point bubbles. In both cases the shape of the bubble distributions depends on a balance between buoyancy and turbulent dispersion, which can be expressed with a Rouse number. Simultaneous PIV and bubble shadowgraphy measurements enable the measurement of fluid statistics around the bubble locations. Bubbles are located in fluid regions with a downward velocity that compensates for the bubble rise velocity.

**DISSERTATIONS**

-

**SCIENTIFIC PUBLICATIONS**

1. Harleman M, Delfos R, Westerweel J, Terwisga T van, PIV validation of local skin friction measurements with a custom built direct force sensor in a low velocity turbulent boundary layer, Smooth conference, Istanbul May 20-21 2010.

**PROJECT AIM**

The main objective of the project is to explore and develop a novel and revolutionary technology for manipulation of fluids on a microscopic scale. The technology is inspired by a fluid manipulation mechanism found in nature, namely that of cilia propulsion. In this case, flow is induced by the concerted beating of individual microscopic hairs, the cilia, that cover the surface of a micro-channel. A test set-up is assembled at the TU Delft to quantitatively characterize the cilia motion and the flow induced by the artificial cilia.

**PROGRESS**

The fluid transport produced by rectangular shaped, magnetically actuated artificial cilia was determined by means of phase-locked Micro Particle Image Velocimetry measurements in a closed flow volume. The achieved velocities are one order of magnitude higher than in previous studies (Shields2010, Vilfan2009), reaching values that are comparable with other microfluidic transport mechanisms such as electro-osmotic pumping. An analysis of the measured flow data was performed indicating that the present system is capable of achieving volume flow rates of approximately 14 micro l/min when no back pressure is built up in the micro channel. This corresponds to an effective pressure gradient of approximately 6 Pa/m. Time resolved measurements were performed, showing that the flow field reverses two times during one actuation cycle inducing instantaneous velocities of up to 2 mm/s.

**DISSERTATIONS**

-

**SCIENTIFIC PUBLICATIONS**

-

**PROJECTLEADERS**

J Westerweel, BJ Boersma,  
G Ooms, JCR Hunt, B Eckhardt

**RESEARCHTHEME**

Complex dynamics of fluids

**PARTICIPANTS**

J Hussong, W-P Breugem

**COOPERATIONS**

Eindhoven University of Technology,  
University of Groningen, Zernike,  
Institute for Advanced Materials  
University of Freiburg-IMTEK,  
Department of Microsystems  
Engineering, Philips Research  
Laboratories, Materials Technology

**FUNDED**

Philips	-
University	-
FOM	-
STW	-
NWO Other	-
Industry	-
TNO	-
GTI	-
EU	100%
Scholarships	-

**START OF THE PROJECT**

2008

**INFORMATION**

J Hussong  
015 278 5797  
j.hussong@tudelft.nl



**PROJECT LEADERS**

J Westerweel, BJ Boersma,  
G Ooms, JCR Hunt, B Eckhardt

**RESEARCH THEME**

Complex dynamics of fluids

**PARTICIPANTS**

H Kim, GE Elsinga, C Poelma,  
J Westerweel

**COOPERATIONS**

ASML, UT, TU/e

**FUNDED**

FOM	
University	-
FOM	100%
STW	-
NWO Other	-
Industry	-
TNO	-
GTI	-
EU	-
Scholarships	-

**START OF THE PROJECT**

2008

**INFORMATION**

H Kim  
015 278 2947  
H.Kim@tudelft.nl  
www.ahd.tudelft.nl

Full 3D-3C velocity distribution and iso-contour plot in the liquid immersion droplet on the moving substrate ( $V_w = 1.0$  m/s) at  $Re = 200$ , where the vectors show 3D-3C velocity components and the iso-contour represents the out-of-plane velocity component. The red boxes show the streamline results at the cross sectional planes ( $y = 0.0, 0.3, 0.6$  mm) where the streamline colors indicate the magnitude of  $w$  velocity. The white surface contour indicates the external shape of the liquid immersion droplet on the moving substrate.

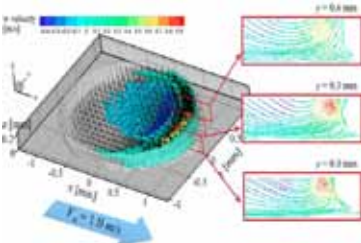

**PROJECT AIM**

This project aims to visualize and investigate the complex flow patterns that occur in a confined Couette flow that resembles a moving droplet of an immersion lens geometry, and to understand how this interacts with the dynamics of the moving contact line. We will make use of the newly developed stereoscopic micro particle image velocimetry ( $\mu$ -PIV), as well as numerical simulations to gain a better understanding of the various flow patterns that occur at intermediate flow Reynolds numbers. The results should lead to strategies that can achieve flow control and to optimized design of a moving immersion lens.

**PROGRESS**

The first measurement result was obtained from 3D PTV which was the original method of choice. From this measurement technique, we observed three-dimensional velocity vectors in the liquid immersion droplet. However, in order to improve the measurement results we have used the new measurement technique, that is tomographic particle image velocimetry (Tomo-PIV). In the case of Tomo-PIV, there is no information loss during the 3D cross-correlation to reconstruct the vector field. As a consequence, we obtained the fully resolved 3D-3C velocity vectors in the liquid immersion drop. From our measurement results, we could understand the internal flow field and provide the boundary condition nearby the moving contact lines. In addition, we observed the self-similar flow pattern near the moving contact lines. Beyond the measurement of the flow field, by the shadowgraphy measurement, we have investigated the transition of the droplet shape as increasing the speed of the substrate. Then, we observed extra two similarities: Cox-Voinov model and 3D lubrication model. In addition, we found the inertial effect on the drop above the moving substrate. Based on these similarities and the inertial effect, we are in the middle of studying the droplet break-up at the high Reynolds number.

**DISSERTATIONS**

-

**SCIENTIFIC PUBLICATIONS**

1. Hyoungsoo Kim, Sebastian Große, Gerrit Elsinga, and Jerry Westerweel, "Full 3D-3C velocity measurement inside a liquid immersion droplet," revised, *Exp Fluids*.
2. Hyoungsoo Kim, Sebastian Große, and Jerry Westerweel, "Assessment of fundamental flow pattern inside a liquid immersion droplet," *MicroNano Conference 2010, Enschede, the Netherlands, Nov. 2010*.
3. Hyoungsoo Kim, Mark Franken, Sebastian Große, Gerrit Elsinga, and Jerry Westerweel, "micro-PIV inside a moving immersion droplet," Invited lecture, *International Symposium on Micro/Nano Flow Measurement Techniques, Tokyo, Japan, Sept. 2010*.
4. Hyoungsoo Kim, Sebastian Große, Michel Riepen, and Jerry Westerweel, "Experimental investigation of internal flow in an immersion droplet by 3D PTV," *Proc. of the 14th International Symposium on Flow Visualization, Daegu, Korea, June 2010*.

**PROJECT AIM**

Fluid mechanics plays a critical role in the formation and adaption of vascular networks. The wall shear stress has been identified as one of the key parameters in this interaction. This project will focus on the quantification of flow conditions relevant for angiogenesis and vascular adaption. With a recently developed micro-PIV method for in-vivo measurement of blood flow, it is possible to measure instantaneous flow and wall shear stress data. This micro-PIV system will be used for in-vivo measurements of the vitelline network and cardiovascular system in chicken embryos.

**PROGRESS**

The measurement depth in micro-PIV measurements, defined by the depth-of-correlation, depends on microscope specific parameters and the tracer particle size. For in-vivo measurements performed in the vitelline network of the chicken embryo, the measurement depth is relatively large. A method has been developed in order to interpret the measured velocity data correctly. This method has been validated in a known reference flow: a glass capillary. Velocity data can provide hemodynamic parameters relevant for the development of a vessel network. When during the development the network's topology and velocity field are obtained consecutively, the insights in the relation between development and flow can be improved. The procedure for obtaining flow velocities has been adapted and performing consecutive PIV-measurements at different stages in the development becomes realizable.

**DISSERTATIONS**

-

**SCIENTIFIC PUBLICATIONS**

-

**PROJECTLEADERS**

J Westerweel, BJ Boersma,  
G Ooms, JCR Hunt, B Eckhardt

**RESEARCHTHEME**

Complex dynamics of fluids

**PARTICIPANTS**

A Kloosterman, C Poelma,  
J Westerweel

**COOPERATIONS**

Leiden University MC and Erasmus  
MC Rotterdam

**FUNDED**

TU Delft	
Universiy	100%
FOM	-
STW	-
NWO Other	-
Industry	-
TNO	-
GTI	-
EU	-
Scholarships	-

**START OF THE PROJECT**

2008

**INFORMATION**

A Kloosterman  
015 278 4194  
a.kloosterman@tudelft.nl  
www.ahd.tudelft.nl

**PROJECT LEADERS**

J Westerweel, BJ Boersma,  
G Ooms, JCR Hunt, B Eckhardt

**RESEARCH THEME**

Complex dynamics of fluids

**PARTICIPANTS**

V Koschatzky, BJ Boersma,  
J Westerweel

**COOPERATIONS**

-

**FUNDED**

FOM  
University -  
FOM 100%  
STW -  
NWO Other -  
Industry -  
TNO -  
GTI -  
EU -  
Scholarships -

**START OF THE PROJECT**

2007

**INFORMATION**

V Koschatzky  
015 278 2861  
v.koschatzky@tudelft.nl  
www.ahd.tudelft.nl/~valentina

**PROJECT AIM**

Identification of the acoustic sources by mean of Particle Image Velocimetry and application of integral methods to the experimental data for the estimation of the sound emission.

**PROGRESS**

In the last year we continued in the development of different techniques for the estimation of the acoustic far-field based on experimental PIV data. In particular we worked on the application of "Curle's analogy" and "Theory of Vortex Sound" to our experimental data [2]. Furthermore, we performed a time-resolved PIV experiment (Figure 1) of which we are currently analyzing the outcomes (Figure 2). Those new data are important to estimate the influence of the 3-dimensional effects in the computation of the acoustic source terms for quasi 2-dimensional flows, as the one under investigation.

**DISSERTATIONS**

-

**SCIENTIFIC PUBLICATIONS**

1. V. Koschatzky, P. Moore, J. Westerweel, F. Scarano and B.J. Boersma, High speed PIV applied to aerodynamic noise investigation, Experiments in Fluids, 2010.
2. V. Koschatzky, J. Westerweel and B.J. Boersma, Comparison of two acoustic analogies to experimental PIV data for cavity sound emission estimation, 16th AIAA/CEAS Aeroacoustics Conference, June 7-9 2010, Stockholm, Sweden.

PIV Tomographic set-up

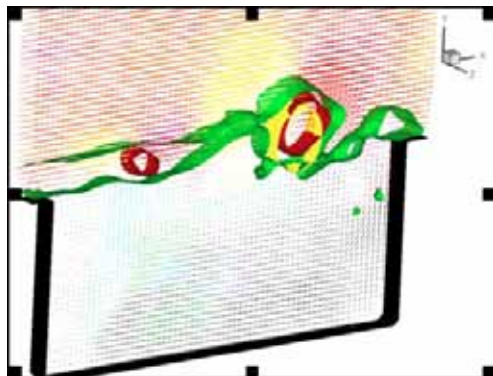
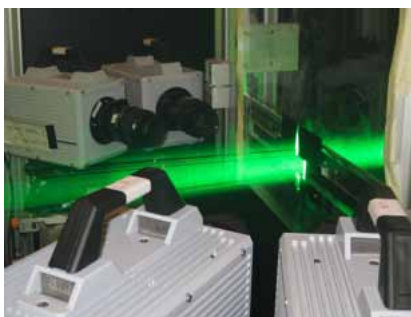

Isosurfaces: Vorticity magnitude (Green), Pressure (Yellow), Q criterion (Red)

## STEPS TO TURBULENCE: PATTERNS IN PIPE FLOW (STEPS)

### PROJECT AIM

Recently theoretical/numerical investigations have shown the existence of flow patterns in the form of non-linear traveling waves, which are exact solutions of the Navier-Stokes equations. Although these structures are unstable, they were confirmed by experiments and has given rise to a new view on transition in pipe flow. The aim of the current project is to explore this new and exciting development by studying these traveling waves in a turbulent pipe flow in a setup with slowly reducing Reynolds number. For the measurements a state-of-the-art high speed stereo PIV system will be used to determine the role of the traveling waves in the dynamics of turbulence.

### PROGRESS

For a more detailed study of the localised turbulent structures a DNS has been initialized to study these localised structures in more detail. Main conclusion of that work is that almost all simulations performed so far were underresolving the flow structures, thereby they have been unable to capture key features that were observed in experimental data. With the current DNS we are able to resolve these features and are investigation their significance to the global behaviour of the turbulent puff.

### DISSERTATIONS

-

### SCIENTIFIC PUBLICATIONS

1. D.J. Kuik, C.Poelma and J. Westerweel. Quantitative Measurement of the Lifetime of Localized Turbulence in Pipe Flow. *Journal of Fluid Mechanics*, 645, 529-539.
2. D.J. Kuik, C.Poelma, M.J.B.M. Pourquie, B.J. Boersma, B.Eckhardt and J. Westerweel. Dynamics of large scale structures in localized turbulence. EFMC-8, Bad Reichenhall, Germany.
3. J. Westerweel and D.J. Kuik. Dynamics of Coherent Structures in Localized Turbulence in a Pipe. 63rd APS meeting, Long Beach, California.

### PROJECTLEADERS

J Westerweel, BJ Boersma,  
G Ooms, JCR Hunt, B Eckhardt

### RESEARCHTHEME

Complex dynamics of fluids

### PARTICIPANTS

DJ Kuik, C Poelma, GE Elsinga,  
M Pourquie, J Westerweel

### COOPERATIONS

-

### FUNDED

Stichting Fundamenteel Onderzoek  
der Materie (FOM), Dynamics of  
Patterns

University	-
FOM	100%
STW	-
NWO Other	-
Industry	-
TNO	-
GTI	-
EU	-
Scholarships	-

### START OF THE PROJECT

2007

### INFORMATION

DJ Kuik  
015 278 4766  
d.j.kuik@tudelft.nl  
www.ahd.tudelft.nl

#### PROJECT LEADERS

J Westerweel, BJ Boersma,  
G Ooms, JCR Hunt, B Eckhardt

#### RESEARCH THEME

Complex dynamics of fluids

#### PARTICIPANTS

M Kwakkel, WP Breugem,  
BJ Boersma

#### COOPERATIONS

Dr. Lifeng Zhang, Missouri University  
of Science & Technology

#### FUNDED

TU Delft	
University	100%
FOM	-
STW	-
NWO Other	-
Industry	-
TNO	-
GTI	-
EU	-
Scholarships	-

#### START OF THE PROJECT

2008

#### INFORMATION

M Kwakkel  
015 278 4194  
m.kwakkel@tudelft.nl  
www.ahd.tudelft.nl/~marcelk

#### PROJECT AIM

The goal of this project is on understanding droplet dynamics and turbulence modification in the clustering regime  $St \sim 1$ . Droplets whose characteristic size is significantly larger than the Kolmogorov length scale are considered, whence they can not be modeled as point droplets. Situations leading to break-up and coalescence of these droplets are of particular interest. Finally, direct numerical simulations of a turbulent channel flow with a large number of droplets will be performed.

#### PROGRESS

Since the goal is to simulate a large number of droplets, the efficiency of the original code was improved. Therefore, three improvements were implemented: a local marker method to capture the interface, a two-level preconditioner for the conjugate gradient method based on deflation, and a multidimensional parallelization. For a simulation of the buoyant rise of 48 droplets in a periodic box, these improvements achieve a speed up of about 8. To be able to simulate droplet coalescence, the drainage and rupture of the thin film have to be modeled sufficiently accurate. With the purpose of testing coalescence models, simulations of the development of the thin film between two colliding droplets were performed. These results will be validated with available theoretical film drainage models.

#### DISSERTATIONS

-

#### SCIENTIFIC PUBLICATIONS

1. Kwakkel, M., Breugem, W.P., Boersma, B.J. (2010). Direct Numerical Simulation of a buoyant droplet array. In Proceedings of the Ercoftac Workshop Direct and Large-Eddy Simulations 8 (DLES8), TU/e, Eindhoven, The Netherlands, 7-9 July, 2010. (Ercoftac Series). Berlin: Springer.

**PROJECT AIM**

To understand the role of gravity in biological systems one may decrease it going into free-fall conditions such as available on various platforms. Unfortunately, these experiments are expensive. Thus, techniques, like Random Positioning Machines (RPM), are widely used to simulate the micro-gravity environment. These instruments generate random movements so that gravitational effects cancel out over time. However, comparative studies performed with the RPM machine were unable to reproduce the clear-cut space flight results. These differences may be explained by undesirable stresses acting on the culture cells. The aim of this study is to predict fluid flow behaviour in an RPM container experimentally using particle image velocimetry imaging and numerically using 3D and time-dependent numerical modeling.

**PROGRESS**

For rotation around a single axis, fluid motion induced by inertia is observed parallel to the wall with good agreement between simulated and measured velocity field. Furthermore, boundary layers can be observed near the bottom. For spin-up about the X and Y axis according to the instantaneous angular velocity used in an RPM, more complex patterns are obtained in the DNS. A maximum velocities up to 7 cm/s near the wall and a maximum stress at the container wall of 62 mPa are derived. For simple rotating motion, quantitative agreement between simulated and measured velocity field have been found. Considering motions as are employed for RPM, the numerical study suggests that stresses induced by the fluid are particularly high during changes of rotation velocity, i.e. acceleration, for cells cultured at the flask wall. At the conference, we aim to present a qualitative comparison between experimental and numerical results. Furthermore, numerical estimation of stresses acting on floating cells will be assessed.

**DISSERTATIONS**

-

**SCIENTIFIC PUBLICATIONS**

-

PIV system and the water filled flask mounted on a two-axis rotating frame

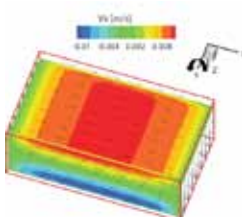
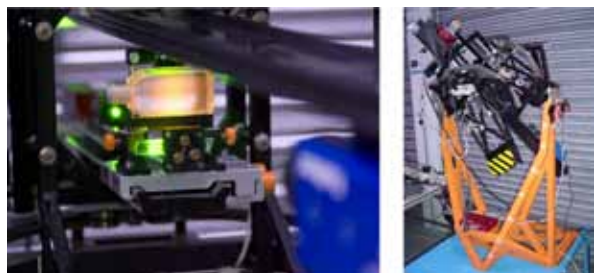

Simulated (left) and measured (right) velocity (relative to the container) during spin-up about the Y-axis for a fluid which is initially at rest for an acceleration  $\ddot{\Omega}_y = 30 \text{ deg/s}^2$  and a maximum angular velocity  $\dot{\Omega}_y = 60 \text{ deg/s}$ . PIV measurements are obtained in the X-Y plane at 5 mm from the wall.

**PROJECT LEADERS**

J Westerweel, BJ Boersma, G Ooms, JCR Hunt, B Eckhardt

**RESEARCH THEME**

Complex dynamics of fluids

**PARTICIPANTS**

CAD Leguy, R Delfos, M Pourquie, C Poelma, J van Loon (VU, Amsterdam), J Westerweel

**COOPERATIONS**

Vrije Universiteit medisch centrum, Amsterdam, NRL (National Aerospace Laboratory), Amsterdam Bioclear, Groningen

**FUNDED**

NOW-SRON (Netherlands Institute for Space Research)

University	-
FOM	-
STW	-
NWO Other	100%
Industry	-
TNO	-
GTI	-
EU	-
Scholarships	-

**START OF THE PROJECT**

2009

**INFORMATION**

C Leguy  
015 278 8351  
c.a.d.leguy@tudelft.nl

**PROJECT LEADERS**

J Westerweel, BJ Boersma,  
G Ooms, JCR Hunt, B Eckhardt

**RESEARCH THEME**

Complex dynamics of fluids

**PARTICIPANTS**

G Oldenziel, G Elsinga, R Delfos,  
J Westerweel

**COOPERATIONS**

-

**FUNDED**

University	-
FOM	100%
STW	-
NWO Other	-
Industry	-
TNO	-
GTI	-
EU	-
Scholarships	-

**START OF THE PROJECT**

2009

**INFORMATION**

G Oldenziel  
015 278 6597  
G.Oldenziel@tudelft.nl  
www.ahd.tudelft.nl/~gosse

**PROJECT AIM**

From the Gulf of Mexico to car engines, dispersed fluid-fluid dispersed multiphase flows can be encountered. In order to let micro organisms get rid of the oil in the Gulf of Mexico it is of importance to disperse the oil in small droplets. In car engines smaller droplets of fuel will make the car more energy efficient. Thus break-up of droplets, and its counterpart, coalescence, is of importance in a number of practical applications. Also on a more fundamental level, a number of questions concerning the influence of turbulence on, for example, the droplet size distribution, are under investigation. The aim of the project is thus to increase the fundamental understanding of coalescence and break-up of droplets in turbulent flows.

**PROGRESS**

In order to test existing models of coalescence between two droplets an experiment is performed. A layer of oil was put on top of a layer of water and a droplet of oil is released from below. The droplet will rise and, after bumping into the interface, lie at the interface for a small time. During this time the thin water film between the oil drop and the oil on top will drain. When the film has a thickness in the order of several hundreds of Angstrom the film will rupture and the drop will coalesce with the oil on top. Using Laser Induced Fluorescence (LIF) the film thickness was observed during the drainage process. In disagreement with the assumptions in the models the drainage is not symmetrical and the observed times to coalescence are much smaller than the predictions by these models. At present, DNS simulations are being performed and the results indicate that the asymmetry is also observed in the simulations. In the next phase of the project tomographic particle image velocimetry, possibly in combination with LIF, will be used to study fully turbulent dispersed multiphase flows.

**DISSERTATIONS**

-

**SCIENTIFIC PUBLICATIONS**

-

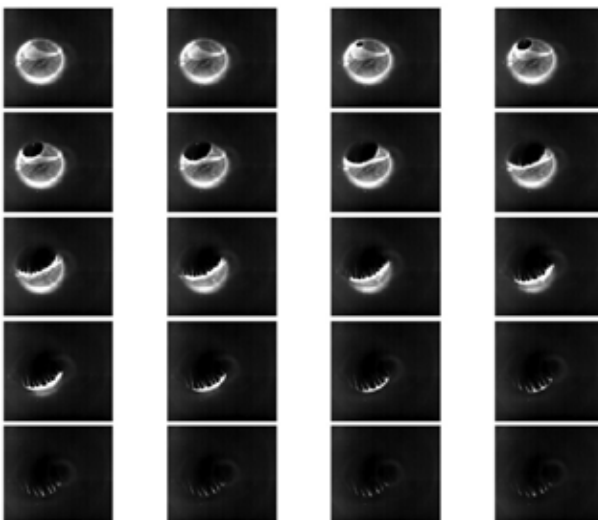

**PROJECT AIM**

We analyze and quantify the role of fluid mechanics in biomedical applications, in particular relating to cardiovascular flow. We do this by developing and applying in vivo flow measurement techniques to document blood flow patterns and the associated hemodynamic forces. Furthermore, we study disease-related blood flow phenomena in vitro (e.g. transition to turbulence in a stenosis, flow patterns in an aneurysm).

**PROGRESS**

We extended our microscopic Particle Image Velocimetry (PIV) so that we were able to document the 3D distribution of the wall shear stress in the outflow tract of an embryonic chicken heart, knowledge of which is essential to understand cardiovascular development. Furthermore, we introduced a refinement in the analysis of PIV data obtained in non-stationary flows (e.g. due to a pulsating heart). This method greatly improves the accuracy of the results in these flows. Finally, we were able to measure flow patterns and wall shear stresses in flows that are not optically accessible, by means of ultrasound PIV. This shows great promise for non-invasive monitoring of e.g. the forces on atherosclerotic plaques in carotid arteries.

**DISSERTATIONS**

-

**SCIENTIFIC PUBLICATIONS**

1. Poelma C., Van der Heiden K., Hierck B.P., Poelmann R.E. and Westerweel J. (2010) "Measurements of the wall shear stress distribution in the outflow tract of an embryonic chicken heart" J Roy Soc Interface 7:91-103.

**PROJECT LEADERS**

J Westerweel, BJ Boersma,  
G Ooms, JCR Hunt, B Eckhardt

**RESEARCH THEME**

Complex dynamics of fluids

**PARTICIPANTS**

C Poelma, A Kloosterman,  
J Westerweel

**COOPERATIONS**

Erasmus MC, LUMC, AMC

**FUNDED**

TU Delft	
University	100%
FOM	-
STW	-
NWO Other	-
Industry	-
TNO	-
GTI	-
EU	-
Scholarships	-

**START OF THE PROJECT**

2006

**INFORMATION**

C Poelma  
015 278 2620  
c.poelma@tudelft.nl



## DEVELOPMENT AND APPLICATION OF VOLUMETRIC VELOCITY MEASUREMENT TECHNIQUES

### PROJECT LEADERS

J Westerweel, BJ Boersma,  
G Ooms, JCR Hunt, B Eckhardt

### RESEARCH THEME

Complex dynamics of fluids

### PARTICIPANTS

N Semin

### COOPERATIONS

-

### FUNDED

FOM	
University	-
FOM	100%
STW	-
NWO Other	-
Industry	-
TNO	-
GTI	-
EU	-
Scholarships	-

### START OF THE PROJECT

2008

### INFORMATION

N Semin  
015 278 6656  
N.V.Semin@tudelft.nl  
www.ahd.tudelft.nl

### PROJECT AIM

Development and Application of Volumetric Velocity Measurement Techniques based on digital holographic imaging and tomographic imaging. The methods will be employed in the investigation of turbulent and instationary flows at both large scales and small scales. The results will be compared with those obtained from numerical simulations. The project interacts with ongoing research on the role of coherent flow structures in turbulent flows and small-scale flows.

### PROGRESS

In 2010 the main focus of the research was on the outer-structure of a zero-pressure-gradient turbulent boundary layer and turbulent jet. The goal is to address several questions, such as: entrainment mechanism and its governing scales, internal shear layers and shear sheltering hypothesis, lagrangian behavior of fluid-elements in the vicinity of a turbulent / non-turbulent interface. Eventually, in the outcome, we may draw parallels between the flows. For this purpose we performed multiple TPIV experiments in these flows at different Reynolds numbers to capture flow regions of interest with sufficient resolution. Analysis is now in progress. Check figure below for some preliminary results.

### DISSERTATIONS

-

### SCIENTIFIC PUBLICATIONS

1. Semin N. V., Poelma C., Drost S. and Westerweel J. Application of digital holography to filament size analysis. *Measurements Science and Technology*, 2010, 21, 075301 (<http://iopscience.iop.org/0957-0233/21/7/075301>).
2. Semin NV, Elsinga G. and Westerweel J. Correlation between large- and small-scale motions in a turbulent boundary layer. Accepted abstract for the Seventh International Symposium on Turbulence and Shear Flows Phenomena. July 28 - 31, 2011, Ottawa, Canada.

(a) is a schematic of the experimental setup. (b) are several instantaneous profiles of the x-component of the velocity at different equidistant spanwise cross-sections. Notice that local velocity reaches the free-stream not smoothly, but rather via a characteristic shear-layer. (c) is an example of an instantaneous velocity field in TBL. Vectors show y- and z-components of the velocity ( $V, W$ ). Only each second vector is plotted. Grey color map designates the x-component of the velocity ( $U$ ). The solid black line shows the location of the T/NT interface. (d) is the conditionally-averaged x-component of the velocity  $\langle U \rangle_I$ . "That's exactly the shear sheltering!"

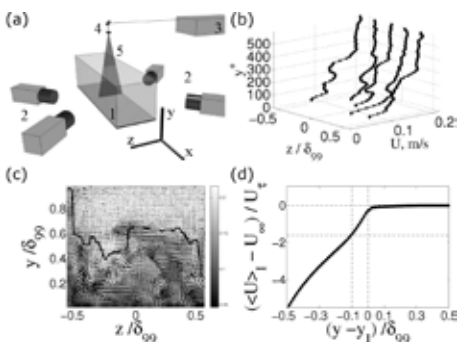

### PROJECT AIM

The aim of this research proposal is to investigate how large gas bubbles rising through a turbulently flowing liquid-particle suspension interact with the particles of the suspension. More specifically, we will investigate how the solid particles adhere to the surfaces of the bubbles, or get entrapped in the wakes of the bubbles, both leading to an upward transport of the particles. This mechanism, called flotation, is primarily investigated by experimental methods.

### PROGRESS

During 2010, some more simultaneous 2-phase PIV experiments were done using larger particles, finally showing a measurable increase in particle concentration in the near-wake of a spherical-cap object. Several methods were tried to get quantitative concentration data from the older measurements as well. Despite complexities in the normalization of the integrated scattered light intensity, a small concentration increase could be proved for the particles with low response times as well. All the data was found to be in good agreement with a simple model for the entrainment of buoyant particles in wakes of spherical-cap bubbles, which was derived by us from first principles. Both the model and the experimental data is going to be published in 2011.

### DISSERTATIONS

-

### SCIENTIFIC PUBLICATIONS

-

### PROJECT LEADERS

J Westerweel, BJ Boersma,  
G Ooms, JCR Hunt, B Eckhardt

### RESEARCH THEME

Complex dynamics of fluids

### PARTICIPANTS

N Warncke, R Delfos, J Westerweel,  
G Ooms

### COOPERATIONS

-

### FUNDED

STW, Corus RT&D  
University -  
FOM -  
STW 75%  
NWO Other -  
Industry 25%  
TNO -  
GTI -  
EU -  
Scholarships -

### START OF THE PROJECT

2007

### INFORMATION

N Warncke  
015 278 2961  
n.g.w.warncke@tudelft.nl  
www.ahd.tudelft.nl/~norbert

### PROJECT LEADERS

J Westerweel, BJ Boersma,  
G Ooms, JCR Hunt, B Eckhardt

### RESEARCH THEME

Complex dynamics of fluids

### PARTICIPANTS

O Zverkhovskiy, M Harleman,  
D van Gils, T van Terwisga,  
J Westerweel, D Lohse, R Delfos

### COOPERATIONS

Delft University of Technology  
Twente University, PPG industries,  
MARIN

### FUNDED

STW, PPG, MARIN	
University	87%
FOM	-
STW	-
NWO Other	-
Industry	-
TNO	13%
GTI	-
EU	-
Scholarships	-

### START OF THE PROJECT

2009

### INFORMATION

O Zverkhovskiy  
015 278 2861  
O.Zverkhovskiy@tudelft.nl

### PROJECT AIM

The aim of this project is to enhance the effects of air lubrication on frictional drag significantly, by improving our knowledge on the detailed mechanisms and its scale effects. With this knowledge the effectiveness of air lubrication should be increased in order to make application on ships feasible.

### PROGRESS

A horizontal pipe setup used to study the influence of air bubbles on frictional drag reduction. A local shear stress sensor was used to measure the shear stress in the pipe locally. Also the pressure drop was measured by a pressure transducer in order to calculate the average wall shear stress along a section of pipe length. Up to 20% local drag reduction was measured at the top part of the pipe. A new test section has been designed for a cavitation tunnel at Maritime & Transport Department, TU Delft. The new setup will allow studying air lubrication on a flat plate.

### DISSERTATIONS

-

### SCIENTIFIC PUBLICATIONS

1. Zverkhovskiy O, et al. 2010. Experimental study on frictional drag reduction by air injection in horizontal water pipe flow. International Conference on Ship Drag Reduction SMOOTH-SHIPS, Istanbul, Turkey, pp 33-40.





Prof.dr.ir. RHM Huijsmans



Prof.dr.ir. TJC van Terwisga

### SEAKEEPING AND MANOEUVRING - PROF. RHM HUIJSMANS

Research of the Chair of Ship motions and manoeuvring is at present focused on the following areas: 1. Non-linear behaviour of fast craft in waves; 2. Extreme wave events in relation to stationary floating structures; 3. Very Large Floating Structures at sea; 4. Prediction of manoeuvring forces based on CFD methods.

High speed ships traveling in waves experience large amplitude motions which can lead to strong non-linear effects in the loads on the hull girder. These non-linear effects are due partly to the large changes in the wetted part of the hull in waves and partly due to non-linear pressure effects. Extreme wave events (breaking waves etc.) can lead to high impact loads on stationary floating structures, e.g. bow loads on Floating Production and Storage vessels for the oil industry. Hydrodynamic analysis of such behaviour is now moving towards application of CFD methods to determine the local flow at the bow. In order to simulate open sea conditions, the CFD region will be connected to an outer region which will be described by potential flow methods. This will allow waves to enter the region local to the bow and reflected waves to travel away from the bow thus minimizing reflections from the CFD boundary. Very Large Floating Structures are being investigated world-wide for various applications such as airports and for floating cities. This research is aimed at developing a novel concept of a large floating structure based on the use of air cushions to support the structure and distribute the wave loads thus optimizing both motion behaviour and structural costs. Manoeuvring models for ships have traditionally been based on equations of motions using experimentally determined drag, mass and lift coefficients. This research aims to investigate the applicability of CFD methods in determining the hydrodynamic coefficients for existing mathematical models. Use is made of a RANS code developed by MARIN and modified to accommodate oblique flow.

### PROPULSION AND RESISTANCE - PROF. T VAN TERWISGA (PART TIME)

Research at the Chair of propulsion and resistance is focussed on three areas: 1. Cavitating Flows; 2. Ship-Propeller-Engine system in Service Conditions; 3. Drag reduction through air lubrication.

Cavitation remains an important field of investigation in Marine Technology. Almost all propellers in operation show cavitation in some but mostly in all working conditions. Cavitation often is an important source of vibrations and sometimes even cavitation erosion. Cavitation on propellers should therefore be controlled as much as possible in both the design and during operations. As cavitation often appears to be extremely unsteady and unstable, this poses a continuing challenge to designers and research groups. The more so because an acceptable cavitation control and a high propulsive efficiency are often conflicting requirements. The Delft Cavitation Tunnel has proven to be a strategic tool for enhancing our understanding of the physics and engineering characteristics. There are currently two PhD projects addressing this issued: One on unsteady sheet cavitation (E.J. Foeth) and another on propeller radiated pressure fluctuations (E.v.Wijngaarden). Ship-Propeller-Engine system analysis and simulation is important to reduce e.g. radiated noise from the propeller and to reduce wear of the propulsion system during its operation. To this end, a close cooperation exists with the section of Marine Engineering. There is currently a PhD project concerned with the development of a model podded propeller for testing in operational conditions (G. Oosterhuis), and a recent PhD project on improved propulsion control for Naval Vessels (A.Vrijdag). Initiatives in the third area on Drag reduction through air lubrication are currently under way.

## ACTIVE MOTION CONTROL OF FAST SHIPS

### PROJECT AIM

The aim of the PhD project is to develop an active motion control system applicable for fast planing ships. The heave, pitch and roll motions are controlled using active flaps or interceptors located at the stern of the vessel. An anticipating controller will be developed that uses a wave sensor to register the waves some distance in front of the ship. A very fast onboard simulation model of the actual ship operating in waves will be used to find the optimal settings of the control devices.

### PROGRESS

The literature review is initiated and a project planning has been established. Currently the setup for the design and preparation of towing tank experiments is carried out. During these tests the frequency dependent forces of the actuators are measured and quantified. These results will be used in the ship simulation model to predict the motion response of the vessels due to the oscillating motion of the control surfaces.

### DISSERTATIONS

-

### SCIENTIFIC PUBLICATIONS

-

### PROJECT LEADERS

RHM Huijsmans

### RESEARCH THEME

Mathematical and computational methods for fluid flow analysis

### PARTICIPANTS

AAK Rijkens, JA Keuning,  
RHM Huijsmans

### COOPERATIONS

-

### FUNDED

Damen Shipyard Group  
Ministry of Defense  
MARIN  
Bureau Veritas  
Lloyd's Register  
Imtech Marine & Offshore  
Quantum Controls  
University 75%  
FOM -  
STW -  
NWO Other -  
Industry 25%  
TNO -  
GTI -  
EU -  
Scholarships -

### START OF THE PROJECT

2011

### INFORMATION

AAK Rijkens  
015 278 6872  
a.a.k.rijkens@tudelft.nl  
www.3me.tudelft.nl/mtt

### PROJECT LEADERS

RHM Huijsmans

### RESEARCH THEME

Mathematical and computational methods for fluid flow analysis

### PARTICIPANTS

JA Keuning, AFJ van Deyzen

### COOPERATIONS

-

### FUNDED

TU Delft, Damen Shipyards, Senter Novem, Maritieme Fondsen

University 25%

FOM -

STW -

NWO Other -

Industry 75%

TNO -

GTI -

EU -

Scholarships -

### START OF THE PROJECT

2007

### INFORMATION

AFJ van Deyzen

015 278 6603

A.F.J.vanDeyzen@TUDelft.nl

### PROJECT AIM

The research and design of an advanced control system for the control of the response of fast vessels in waves. The purpose of this study is to understand how a relatively small planing monohull behaves in rough head seas and how this seakeeping behavior can be influenced by active control of the thrust. An increase of the operability (or: a reduction of the severe response) of these vessels can be achieved by an anticipating control system (pro-active or smart control) of the thrust. Smart control means that the magnitude of the thrust is already determined before the ship actually encounters an incoming wave.

### PROGRESS

A simulation model has been setup which simulates the response of a planing monohull sailing in head seas. A pro-active control system for the thrust has been included.

### DISSERTATIONS

-

### SCIENTIFIC PUBLICATIONS

-

# SEAKEEPING OF HIGH SPEED SHIPS - THE DEVELOPMENT OF A 3D TIME DOMAIN BOUNDARY ELEMENT METHOD (FAST II)

## PROJECT AIM

The aim of the FAST II PhD project is to develop comprehensive and efficient mathematical tools for the evaluation of (nonlinear) motions of high speed vessels. The result of the PhD-project will be a fully validated numerical tool for the evaluation of motions and loads of high speed ships operating in waves based on a time domain potential flow boundary element method.

## PROGRESS

In 2010 the validation of the computational tool has been successfully completed. The main focus has been directed at validating the motions and vertical acceleration levels of high speed ships in head seas. As validation material measurements in irregular waves obtained during a previous research project (FAST I) was used along with additional measurements in regular waves specifically performed for this purpose. The results show excellent agreement between measurements and computations on motions levels and for the global accelerations. The code still needs improvement in dealing with peaks occurring in the vertical acceleration levels associated with impacting of the ship hull with the water surface. This is proposed as future work. The concept dissertation has been completed in 2010 and the defense is planned for October 2011.

## DISSERTATIONS

-

## SCIENTIFIC PUBLICATIONS

-

## PROJECTLEADERS

RHM Huijsmans

## RESEARCHTHEME

Mathematical and computational methods for fluid flow analysis

## PARTICIPANTS

P de Jong, JA Keuning

## COOPERATIONS

-

## FUNDED

Marin Royal Netherlands Navy

Damen Shipyards

Royal Schelde Group

University -

FOM -

STW -

NWO Other -

Industry 100%

TNO -

GTI -

EU -

Scholarships -

## START OF THE PROJECT

2005

## INFORMATION

P de Jong

015 278 3876

pepijn.dejong@tudelft.nl

www.3me.tudelft.nl/mtt





Prof.dr.ir. C van Rhee

Large volumes of sediment are displaced nowadays using different types of dredging equipment. Especially the last decade, large land reclamation projects attained global attention. Examples of these enormous projects are the new airports in Hong Kong and Singapore, the large land reclamations for ports and industry in Singapore, the spectacular projects in Dubai like the palm Islands and “the World” and the Maasvlakte II currently under construction in the Netherlands.

All Dredging processes involve slurry flows and are dominated by erosion, transport and sedimentation under special hydraulic conditions like high volumetric sediment concentration and or high flow velocity.

The research topics within the section of Dredging Engineering are focused on the physical processes encountered during dredging (and mining):

- ♦ Excavation processes of saturated sediments (mechanical, hydraulic or a combination).
- ♦ Hydraulic transportation of sediment water mixtures.
- ♦ Mixing and separation process (like the sedimentation process in a hopper of a Trailing Suction Hopper Dredge)
- ♦ Erosion and settling of sediments.
- ♦ Wear of flow components due to hydraulic transport.

## JETTING COHESIVE SOIL

### PROJECT AIM

The aim of the present research program is to develop physical and mathematical models of the cutting process of a moving submerged (cavitating and non-cavitating ) jet on cohesive soil, in order to be able to predict the jet cutting production in cohesive soil.

### PROGRESS

In 2010 high speed recordings of the jetting process were analyzed. At the end of 2010 all the research activities were completed and a start was made in writing the dissertation.

### DISSERTATIONS

-

### SCIENTIFIC PUBLICATIONS

1. Nobel, A.J., J.Cornelisse and C. van Rhee (2010). High speed recordings of a moving submerged water jet in cohesive soil., Proceedings of the 20th International Conference on Water Jetting, BHR-group, Cranfield.

### PROJECT LEADERS

C van Rhee, F Molenkamp, AM  
Talmon

### RESEARCH THEME

Complex structures of fluids

### PARTICIPANTS

AJ Nobel

### COOPERATIONS

-

### FUNDED

Senter, Royal Boskalis Westminster  
NV, Van Oord Dredging and Marine  
Contractors BV  
University -  
FOM -  
STW 40%  
NWO Other -  
Industry 60%  
TNO -  
GTI -  
EU -  
Scholarships -

### START OF THE PROJECT

2004

### INFORMATION

AJ Nobel  
015 278 9111  
A.J.Nobel@tudelft.nl

## CFD2 PHASE

### PROJECT LEADERS

C van Rhee

### RESEARCH THEME

Mathematical and computational methods for fluid flow analysis

### PARTICIPANTS

J Goeree, C van Rhee, A Talmon, H Bugdayci, TUDelft: C. van Rhee/A. Talmon, IHC: E. van der Blom/H. Bugdayci/H. Van Muijen/ P.M.Vercrujssse/E.A.Munts  
Utwente: H.Hoeijmakers/N.Kruijt

### COOPERATIONS

TUDelft, Utwente, AgentschapNL, IHC Merwede BV

### FUNDED

IHC Merwede BV/AgentschapNL	
University	-
FOM	-
STW	-
NWO Other	50%
Industry	50%
TNO	-
GTI	-
EU	-
Scholarships	-

### START OF THE PROJECT

2010

### INFORMATION

C van Rhee

J Goeree

015 278 3297

j.c.goeree@tudelft.nl

### PROJECT AIM

The project aim is to numerically model the hydrodynamical behavior of water/sediment mixtures for the specific dredging conditions. This is done using constitutive relations, modeling sediment, and the Navier-Stokes equations. The resulting differential equations are solved using numerical techniques. The sediment fractions are described as a continuum, reducing calculation costs.

### PROGRESS

The following actions have been done in the last year:

- set up a numerical framework solving the Navier-Stokes equations, using the Fractional Step Method of Chorin (3D)
- modeling different advection schemes such as first order upwind and various flux limiters
- modeling Turbulence using LES
- literature review of modeling wall functions (e.g. Thin Boundary Layer Equations).

### DISSERTATIONS

-

### SCIENTIFIC PUBLICATIONS

-

## NUMERICAL MODELING OF DREDGE PLUMES

### PROJECT AIM

The aim is to understand the complex mixing of a water-silt-sand-air plume from a dredge vessel with the ambient water. Numerical simulations are carried out for this purpose. Also scale (1:50) and field (1:1) measurements are planned. Due to the non stationary behaviour of a dredge plume the numerical approach is to use LES and not RANS. A big challenge is the large scale of the simulations with very high Reynolds numbers (up to 10 million) on relatively coarse meshes. The end goal is to find the amount of silts (fine sediments) originating from the dredge plume which stay suspended in the water column after the transition to a passive plume has taken place.

### PROGRESS

- Numerical improvement on the CFD code: implementation of RK3 and AB3 time integration schemes, realistic synthetic turbulent inflow conditions, multiple sand/silt fractions in the model.
- Numerical benchmarks: Rayleigh Taylor and plume simulations.
- Scale measurements (1:50) of plumes originating from a dredge vessel. Several different sail velocities, propeller velocities, plume densities, plume forcing frequencies are used.
- Example of a simulation of a dredge plume below.

### DISSERTATIONS

-

### SCIENTIFIC PUBLICATIONS

1. Wit, L de (2010). Near field 3d cfd modelling of overflow plumes. In J Dobson (Ed.), Proceedings of the 19th world dredging congress (pp. 712-723). Beijing,China: Chida.

### PROJECTLEADERS

C van Rhee

### RESEARCHTHEME

Mathematical and computational methods for fluid flow analysis

### PARTICIPANTS

L de Wit

### COOPERATIONS

-

### FUNDED

Building with Nature	-
University	-
FOM	-
STW	-
NWO Other	-
Industry	100%
TNO	-
GTI	-
EU	-
Scholarships	-

### START OF THE PROJECT

2008

### INFORMATION

L de Wit

015 278 3583

[l.dewit@tudelft.nl](mailto:l.dewit@tudelft.nl)

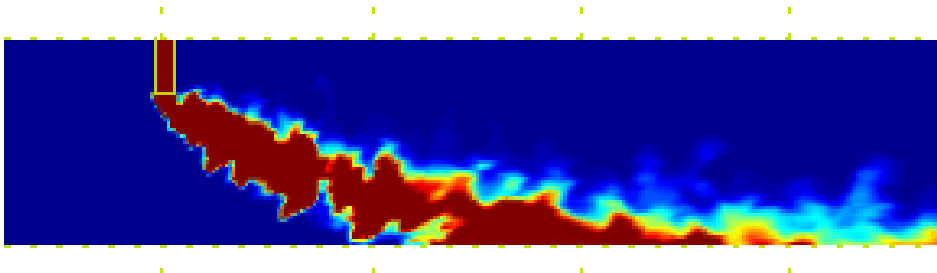

### PROJECT LEADERS

C van Rhee, JP van Leeuwen

### RESEARCH THEME

Mathematical and computational methods for fluid flow analysis

### PARTICIPANTS

C van Rhee, A Talmon, JP van Leeuwen, RJA van Rijswick

### COOPERATIONS

-

### FUNDED

WEIR Minerals Netherlands b.v.

University -

FOM -

STW -

NWO Other -

Industry 100%

TNO -

GTI -

EU -

Scholarships -

### START OF THE PROJECT

2010

### INFORMATION

R van Rijswick

06 39149956

R.J.A.vanRijswick@tudelft.com

### PROJECT AIM

Development of an experimentally validated numerical fluid structure interaction (FSI) model for the prediction of, operating condition induced, diaphragm deformation and strains in piston diaphragm pumps.

### PROGRESS

- Basic literature study in general CFD and FSI
- Programming of explicit 2D Navier-Stokes solver using multigrid method for Poisson equation
- Implementation of immersed boundary method for flexible immersed structures
- Implementation of immersed boundary method for rigid immersed structures
- Design, erection and commissioning of diaphragm deformation test rig

### DISSERTATIONS

-

### SCIENTIFIC PUBLICATIONS

1. Rijswick, R.van, Kuenen J., Wilmsen, A., Sloesen, J. GLORES, the gateway to piston diaphragm pumps for high volume applications, Proceedings of the 18th International conference on Hydrotransport, Rio de Janeiro, Brazil, 22-24 September, 2010.





Prof.dr.ir. C Vuik

The research program of the Numerical Analysis group of TUD belongs to the field of computational science and engineering. We concentrate on the development and application of computing methods to the applied sciences. The focus is on mathematical models relying heavily on partial differential equations, such as occur in fluid dynamics. But we also consider similar mathematical models arising in other fields, for instance materials science and reservoir engineering, usually in cooperation with domain experts. A speciality is problems involving partial differential equations with moving internal boundaries, such as occur in bubbly flows and in phase transition problems. To diminish computing time in large-scale applications, iterative methods for solving large systems of algebraic equations are developed further, using deflation, multi-block, preconditioning and multigrid techniques.

# MATHEMATICAL INVESTIGATION INTO SMOOTHNESS-INCREASING ACCURACY-CONSERVING METHODS FOR STREAMLINE VISUALIZATION

## PROJECT AIM

The purpose of the proposed research is the mathematical and algorithmic development of smoothness-increasing accuracy-conserving filters with application to post-processing and visualizing discontinuous Galerkin simulation results.

## PROGRESS

In 2010 the projects focus was on the two-dimensional extension of the position-dependent filter along with applications to streamline visualization and pointwise error estimates. We have also concentrated our efforts into deriving theoretical error estimates. More precisely, we show that, for a certain class of DG approximations for linear hyperbolic equations, the position-dependent post-processor enhances the accuracy in the entire spatial domain from order  $k+1$  in the  $L_2$ -norm to order  $2k+1$  in the  $L_\infty$ -norm (where  $h$  is the mesh element diameter). Although the position-dependent post-processor can be applied for problems with discontinuous solutions, this theory is restricted to the case where the solution is sufficiently smooth. Additionally, we have been able to study the effect of the post-processor on triangular meshes.

## DISSERTATIONS

-

## SCIENTIFIC PUBLICATIONS

1. P. van Slingerland, J.K. Ryan, Position-Dependent Smoothness-Increasing Accuracy-Conserving (SIAC) Filtering for Accuracy for Improving discontinuous Galerkin solutions, SIAM Journal on Scientific Computing, to appear.
2. H. Mirzaee, J.K. Ryan, R.M. Kirby, Quantification of Errors Introduced in the Numerical Approximation and Implementation of Smoothness-Increasing Accuracy Conserving (SIAM) Filtering of Discontinuous Galerkin (DG) Fields, Journal of Scientific Computing, 45 (2010), 447-470.

## PROJECT LEADERS

JK Ryan

## RESEARCH THEME

Mathematical and computational methods for fluid flow analysis

## PARTICIPANTS

Paulien van Slingerland, Xiaozhou Li

## COOPERATIONS

University of Utah, Salt Lake City, UT

## FUNDED

European Office of Aerospace Research and Development/U.S. Air Force Office of Research and Development

University	20%
FOM	-
STW	-
NWO Other	-
Industry	-
TNO	-
GTI	-
EU	80%
Scholarships	-

## START OF THE PROJECT

2009

## INFORMATION

JK Ryan

015 278 8755

J.K.Ryan@tudelft.nl,

<http://ta.twi.tudelft.nl/NW/users/ryan/>



**PROJECT LEADERS**

C Vuik, A Segal

**RESEARCH THEME**

Complex dynamics of fluids

**PARTICIPANTS**C Vuik, A Segal, JM Tang,  
R Nabben**COOPERATIONS**TU Eindhoven, Sepra, TNO-Science  
and Industry, TU Berlin**FUNDED**

TUD, TNO-TPD, BRICKS

University	25%
FOM	25%
STW	25%
NWO Other	-
Industry	25%
TNO	-
GTI	-
EU	-
Scholarships	-

**START OF THE PROJECT**

1996

**INFORMATION**C Vuik  
015 278 5530  
c.vuik@tudelft.nl  
<http://ta.twi.tudelft.nl/users/vuik>**PROJECT AIM**

The purpose is to improve efficiency of solution methods in computational fluid. Dynamics, porous media flow and related applications. The DICCG (deflated preconditioned conjugate gradients) method will be developed further. The method will be generalized such that reliable termination criteria can be applied. Domain subdivision methods will be developed to make DICCG applicable.

**PROGRESS**

The SEPRAN code is parallelized and works efficiently on parallel platforms. More and more users are simulating with the parallel version. This leads to useful feedback in order to enhance the solver. Theoretically the deflation acceleration is compared with an additive coarse grid correction and a balancing Neumann Neumann preconditioner. It appears that the deflation method leads to the fastest convergence, whereas the work per iteration is less or equal to the other methods. Many (in)compressible Navier-Stokes equation solvers use a splitting method to solve the discretized equation. In many applications, especially in bubbly flows, the pressure equation takes most of the time to be solved. One of the reasons is the jump in the density in gas and water. Multi grid methods can be used but some difficulties remain if the size of the bubbles is very small. In this project the pressure equation is solved by the deflated ICCG method. After optimization it appears that the resulting method is 4-5 times faster than the ICCG method. We plan to make a better choice of the projection vectors and try to combine it with domain decomposition and parallel computing.

**DISSERTATIONS**

-

**SCIENTIFIC PUBLICATIONS**

1. J.M. Tang and S.P. MacLachlan and R. Nabben and C. Vuik. A Comparison of Two-Level Preconditioners Based on Multigrid and Deflation. SIAM. J. Matrix Anal. and Appl., 31, pp. 1715-1739, 2010.
2. B. Koren and C. Vuik Advanced Computational Methods in Science and Engineering, Springer, Berlin, 2010.

**PROJECT AIM**

New preconditioners for the discretized Navier-Stokes equations will be developed. Parallel deflation methods will be included.

**PROGRESS**

The discrete Navier-Stokes equations are solved by the SIMPLE(R) iteration method. To decrease the very large number of iterations, we have proposed multigrid and Krylov accelerated versions: GCR-SIMPLE(R). The properties of these methods are being investigated for simple two-dimensional flows and three-dimensional flows in industrial glass melting furnaces. These methods are generalised to a colocated discretization and combined with the deflated multiblock approach and parallel computing. Now we try to generalize these solvers to our FEM discretization (SEPRAN) and compare our methods with the recently developed methods given by Elman, Wathen, Sylvester, Benzi, Reusken and Schilders. It appears that MSIMPLER, a new variant of SIMPLER, leads to the fastest results. We also develop a solver based on the Schur complement and multigrid. This method is scalable and leads to very good results for geophysical applications. The GCR-simple solver is also implemented and tested in MARIN software.

**DISSERTATIONS**

1. ur Rehman, M (2010, februari 24). Fast iterative methods for the incompressible Navier-Stokes equations. TUD Technische Universiteit Delft (135 pag.) (Delft). Prom./coprom.: Prof.dr.ir. C Vuik & Ir. A Segal.

**SCIENTIFIC PUBLICATIONS**

1. A. Segal and M. ur Rehman and C. Vuik. Preconditioners for Incompressible Navier-Stokes Solvers. Numerical Mathematics: Theory, Methods and Applications, 3, pp. 245-275, 2010.
2. E. van 't Wout and M.B. van Gijzen and A. Ditzel and A. van der Ploeg and C. Vuik. The Deflated Relaxed Incomplete Cholesky CG method for use in a real-time ship simulator. Procedia Computer Science, 1, pp. 249-257, 2010.
3. M. ur Rehman and C. Vuik and G. Segal. Block Preconditioners for the Incompressible Stokes Problem. In: Large-Scale Scientific Computing Editors: I. Lirkov and S. Margenov and J. Wasniewski Lecture Notes in Computer Science, Vol. 5910 Springer, Berlin, 2010, pp. 829-836.

**PROJECTLEADERS**

C Vuik

**RESEARCHTHEME**

Complex dynamics of fluids

**PARTICIPANTS**

C Vuik, S maclaclan, Geenen, A Segal, M ur Rehman

**COOPERATIONS**

TNO-Science and Industry  
Utrecht University, Sepra Tufts  
University USA

**FUNDED**

STW, TUD, TNO-Science and Industry, Nuffic-HEC University	25%
FOM	-
STW	-
NWO Other	-
Industry	75%
TNO	-
GTI	-
EU	-
Scholarships	-

**START OF THE PROJECT**

1992

**INFORMATION**

C Vuik  
015 278 5530  
c.vuik@tudelft.nl  
<http://ta.twi.tudelft.nl/users/vuik>

**PROJECT LEADERS**

C Vuiik, FJ Vermolen

**RESEARCH THEME**

Complex dynamics of fluids

**PARTICIPANTS**

D Ibrahim, FJ Vermolen, C Vuiik

**COOPERATIONS**

TUD, TNO Science and Industry

**FUNDED**

NUFFIC

University 25%

FOM -

STW -

NWO Other -

Industry 75%

TNO -

GTI -

EU -

Scholarships -

**START OF THE PROJECT**

2007

**INFORMATION**

FJ Vermolen

015 278 7298

F.J.Vermolen@tudelft.nl

**PROJECT AIM**

Develop numerical methods for industrial flow problems.

**PROGRESS**

A new method to solve multi-phase fluid flow problems is developed. Dynamic modeling of thermal processes with phase transition by means of the density-enthalpy phase diagram for spatially homogeneous systems. Until now, preliminary results for two spatial dimensions have been obtained. This method eliminates the requirement of different sets of equations for various phases and necessitates fewer assumptions. For spatial domain discretization, we use finite elements. Recently it appears that the required time step is very small. This motivates our research to develop time integration methods which allow large time steps.

**DISSERTATIONS**

-

**SCIENTIFIC PUBLICATIONS**

1. W.K. van Wijngaarden and F.J. Vermolen and G.A.M. van Meurs and C. Vuiik. Modelling the new soil improvement method biogrout: extension to 3D In: Numerical Mathematics and Advanced Applications 2009 Editors: G. Kreiss and P. Lotstedt and A. Malqvist and M. Neytcheva Springer, Berlin, 2010, pp. 893-900.

# DEVELOPMENT OF AN IMMERSED BOUNDARY METHOD IMPLEMENTED ON CLUSTER AND GRID COMPUTERS, APPLICATION TO THE SWIMMING OF FISH

## PROJECT AIM

Development of numerical methods for grid computing application to simulation of swimming of fish.

## PROGRESS

The project started at the end of 2006. Two implementations of the preconditioned Conjugate Gradient method for solving large sparse linear systems of equations on a (local) heterogeneous computing grid were studied, using GridSolve as grid middleware. This was applied to a 3D bubbly flow problem. Then we experimented with using an asynchronous parallel iterative algorithm as a preconditioner with promising results, again using GridSolve. This approach/technique was then implemented in the CRAC middleware, which allows for direct communication between the processes. Experiments using the CRAC implementation were conducted on the DAS-3 supercomputer, which is a cluster of five geographically separated clusters. Initial tests with asynchronous deflation techniques were also conducted, with promising results.

## DISSERTATIONS

-

## SCIENTIFIC PUBLICATIONS

1. Collignon, TP & Gijzen, MB van (2010). Two implementations of the preconditioned conjugate gradient method on heterogeneous computing grids. International journal of applied mathematics and computer science, 20, 109-121.
2. Collignon, TP & Gijzen, MB van (2010). Solving large sparse linear systems efficiently on grid computers using an asynchronous iterative method as a preconditioner. In G Kreiss, P Lötstedt, A Målqvist & M Neytcheva (Eds.), Numerical Mathematics and Advanced Applications 2009 (pp. 261-268). Berlin: Springer.
3. Collignon, TP & Gijzen, MB van (2010). fast Solution of nonsymmetric linear systems on grid computers using parallel variants of IDR (s). Reports of the Department of Applied Mathematics (Ext. rep. 10-5). Delft: EWI Dept. Applied Mathematics.
4. Collignon, TP, Sleijpen, GLG & Gijzen, MB van (2010). Interpreting IDR (s) as a deflation method. Reports of the Department of Applied Mathematics (Ext. rep. 10-12). Delft: EWI Dept. Applied Mathematics.
5. Gijzen, MB van & Collignon, TP (2010). Exploiting the flexibility of IDR (s) for grid computing. In s.n. (Ed.), Proceedings of the 2nd international Kyoto-forum on krylov subspace method (pp. 118-129). Kyoto: Academic Center for Computing and Media Studies.
6. Gijzen, MB van & Collignon, TP (2010). Exploiting the flexibility of IDR (s) for grid computing. Reports of the Department of Applied Mathematics (Ext. rep. 10-11). Delft: EWI Dept. Applied Mathematics.

## PROJECTLEADERS

C Vuiik

## RESEARCHTHEME

Complex dynamics of fluids

## PARTICIPANTS

TP Collignon, MB van Gijzen

## COOPERATIONS

B Koren, (L&R, CWI), Yunus Hassen (CWI)

## FUNDED

TU (DCSE)	
University	100%
FOM	-
STW	-
NWO Other	-
Industry	-
TNO	-
GTI	-
EU	-
Scholarships	-

## START OF THE PROJECT

2006

## INFORMATION

MB van Gijzen

015 278 2519

M.B.vanGijzen@TUDelft.nl

www.cse.tudelft.nl

#### PROJECT LEADERS

C Vuik, CR Kleijn

#### RESEARCH THEME

Complex dynamics of fluids

#### PARTICIPANTS

C Vuik, S van Veldhuizen, C Kleijn

#### COOPERATIONS

TUD/TNW/MSP, TNO Science and Industry, CWI

#### FUNDED

DCSE, TNO Science and Industry	
University	90%
FOM	-
STW	-
NWO Other	-
Industry	10%
TNO	-
GTI	-
EU	-
Scholarships	-

#### START OF THE PROJECT

2004

#### INFORMATION

C Vuik  
015 278 5530,  
C.Vuik@tudelft.nl  
<http://ta.twi.tudelft.nl/users/vuik/>

#### PROJECT AIM

Development of efficient solvers for chemical vapour deposition reactors. The large system of non-linear coupled partial differential equations is very stiff. So efficient time discretization methods are developed. The resulting non-linear systems should be solved very efficiently in order to compute the solution within a reasonable time.

#### PROGRESS

Nowadays, many generally applicable simulation codes are available for computational fluid dynamics. However, most of these codes are unsuited for the simulation of chemically reacting flows. This is due to the numerical stiffness of the coupled systems of advection-diffusion-reaction equations that occur. Currently, we try to solve the system by the Euler backward method, which implies that nonlinear systems have to be solved for each time step. It appears that in some situations the Newton-Raphson method only converges if very small time steps are used. After using the Projected Newton-Raphson method we get good convergence results. We are able to solve 17 species on a 3dimensional geometry with a grid of 50x50x50 grid points in a reasonable time (some hours CPU time). Applications are chemical vapor deposition machines and solid oxide fuel cells.

#### DISSERTATIONS

-

#### SCIENTIFIC PUBLICATIONS

1. S. van Veldhuizen and C. Vuik and C.R. Kleijn. On projected Newton-Krylov solvers for instationary laminar reacting gas flows. *Journal of Computational Physics*, 229, pp. 1724-1738, 2010.
2. S. van Veldhuizen and C. Vuik and C.R. Kleijn. On numerical issues in time accurate laminar reacting gas flow solvers B. Koren and C. Vuik, editors, *Advanced Computational Methods in Science and Engineering* pages 47-78, Springer, Berlin, 2010.

**PROJECT AIM**

The aim is to develop efficient parallel iterative solvers for the Helmholtz problem. In order to estimate the layered structure of the earth crust seismic methods are used. The layer structure is used as input for porous media flow simulations.

**PROGRESS**

A special preconditioner has been developed, which in a special combination of Krylov subspace and multigrid methods has resulted in a hundredfold increase in computing speed for the Helmholtz equation, describing wave propagation. Application in seismics has been very successful, and has generated much interest from the oil exploration industry, especially after a comparison with an industrial code in an application to a practical problem posed by industry. For the first time, realistic three-dimensional applications become feasible. This has already been realized on a single-processor machine for medium-sized problems. The 3D code for the seismic simulation package has been parallelized. Furthermore, a comparison with analytic solutions will be made. The fast solver technique will be generalized to a finite element discretization of the Maxwell equations, for radar simulations.

**DISSERTATIONS**

-

**SCIENTIFIC PUBLICATIONS**

1. P.B. Hooghiemstra and D.R. van der Heul and C. Vuik. Application of the shifted-Laplace preconditioner for iterative solution of a higher order finite element discretisation of the vector wave equation: First experiences Applied Numerical Mathematics, 60, pp. 1157-1170, 2010.
2. C. W. Oosterlee and C. Vuik and W.A. Mulder and R.-E. Plessix. Shifted-Laplacian preconditioners for heterogeneous Helmholtz problems B. Koren and C. Vuik, editors, Advanced Computational Methods in Science and Engineering pages 21-46, Springer, Berlin, 2010.

**PROJECTLEADERS**

C Vuik, CW Oosterlee

**RESEARCHTHEME**

Complex dynamics of fluids

**PARTICIPANTS**

C Oosterlee, C Vuik, D Lahaye, A Sheikh

**COOPERATIONS**

TUD Chem.Tech, Philips, Shell, NLR

**FUNDED**

SenterNovem, NLR, Nuffic University	75%
FOM	-
STW	-
NWO Other	-
Industry	25%
TNO	-
GTI	-
EU	-
Scholarships	-

**START OF THE PROJECT**

2001

**INFORMATION**

C Vuik  
 015 278 5530,  
 C.Vuik@tudelft.nl  
<http://ta.twi.tudelft.nl/users/vuik/>

**PROJECT LEADERS**

FJ Vermolen, S van der Zwaag

**RESEARCH THEME**

Complex dynamics of fluids

**PARTICIPANTS**

FJ Vermolen, PA Prokharau

**COOPERATIONS**

Old Dominion University, Norfolk, USA; Centro de Investigacion Biomedica en Red en Bioingenieria, Zaragoza, Spain

**FUNDED**

DCMAT, Senternovem (NWO)	
University	50%
FOM	25%
STW	25%
NWO Other	-
Industry	25%
TNO	-
GTI	-
EU	-
Scholarships	-

**START OF THE PROJECT**

2003

**INFORMATION**

FJ Vermolen  
015 278 7298  
F.J.Vermolen@tudelft.nl  
<http://ta.twi.tudelft.nl/users/vermolen>

**PROJECT AIM**

-

**PROGRESS**

A publication about modeling wound healing including wound closure, wound angiogenesis and wound contraction has been submitted to Mathematical Biology (Vermolen & Javierre). Furthermore, a paper about a stability analysis of a model for intraosseous bone ingrowth into an implant was accepted (Prokharau & Vermolen) in Mathematical Biology. A model on the gradual differentiation of mesenchymal stem cells has been developed. A paper (Prokharau & Vermolen) has been submitted to Mathematical Biology. Furthermore, a semi-stochastic cell-based model for migrating cell colonies on substrates has been developed. The model incorporates cell division, biased random walk and cell death. A paper (Vermolen & Gefen) has been submitted to Biomechanics and Modeling in Mechanobiology. Finally, a Cahn-Hilliard model has been constructed for the simulation of adipogenesis in adipocytes (fat cells). The model is used to compute the evolution of lipid droplet formation in cytoplasm. A paper (Vermolen & Gefen) is being written.

**DISSERTATIONS**

-

**SCIENTIFIC PUBLICATIONS**

1. F.J.Vermolen & E.Javierre. Computer simulations from a finite-element model for wound contraction and closure. Journal of Tissue Viability, 19, 43-53, 2010.

**PROJECT AIM**

-

**PROGRESS**

A paper on modeling self-healing through a moving boundary problem appeared in the Enumath 2009 proceedings. The paper deals with a level-set method in combination with a cut-cell method for the discretization of the diffusion- reaction equation. The equation contains a discontinuous switch mechanism for the movement of the boundary. A paper (Zemskov, Vermolen & Jonkers) on an analytic approach of the determination of the probability of a crack intersecting an encapsulated particle in concrete has appeared and submitted. The application is in bacterial self healing concrete. The model contains principles from elementary geometry and probability. Further, a model for the actual healing of a crack has been developed. The model contains two different types of moving boundaries. The solution strategy is based on the level set method. A paper about this model is in progress.

**DISSERTATIONS**

-

**SCIENTIFIC PUBLICATIONS**

1. S.V.Zemskov, F.J.Vermolen & H.M.Jonkers. An analytical model for the probability characteristics of a crack hitting an encapsulated self-healing agent in concrete. Computer Algebra in Scientific Computing, CASC 2010, 280-293, 2010.
2. S.V.Zemskov, F.J.Vermolen, E.Javierre, C.Vuik. A cut-cell finite-element method for a discontinuous switch model for wound closure. Enumath 2009 Proceedings, Springer, 2010.

**PROJECTLEADERS**

FJ Vermolen

**RESEARCHTHEME**

Complex dynamics of fluids

**PARTICIPANTS**

FJ Vermolen, SV Zemskov

**COOPERATIONS**

Corusgroup (Aluminium),  
Department of Materials Science  
and Engineering

**FUNDED**

DCMAT	
University	50%
FOM	50%
STW	-
NWO Other	-
Industry	-
TNO	-
GTI	-
EU	-
Scholarships	-

**START OF THE PROJECT**

2003

**INFORMATION**

FJ Vermolen

015 278 7298,

F.J.Vermolen@tudelft.nl

<http://ta.twi.tudelft.nl/users/vermolen>



**PROJECT LEADERS**

FJ Vermolen

**RESEARCH THEME**

Complex dynamics of fluids

**PARTICIPANTS**FJ Vermolen, L Zhao, D den Ouden  
and J Sietsma**COOPERATIONS**Corusgroup (Aluminium),  
Department of Materials Science  
and Engineering**FUNDED**

DCMAT

University 50%

FOM -

STW -

NWO Other -

Industry 50%

TNO -

GTI -

EU -

Scholarships -

**START OF THE PROJECT**

2003

**INFORMATION**

FJ Vermolen

015 278 7298

F.J.Vermolen@tudelft.nl

<http://ta.twi.tudelft.nl/users/vermolen>**PROJECT AIM**

-

**PROGRESS**

A Lifschits-Slyozov-Wagner model for the statistical distribution of the secondary phase particle size has been developed. A paper (den Ouden, Vermolen, Zhao, Sietsma & Vuik) has been submitted to the Journal of Computational Materials Science. Furthermore, a finite-element based formulation of the level-set method has been constructed to account for all kinds of geometry.

**DISSERTATIONS**

-

**SCIENTIFIC PUBLICATIONS**

1. D.den Ouden, F.J.Vermolen, L.Zhao, C.Vuik & J.Sietsma. Mathematical Modeling of NbC particle nucleation and growth in an HSLA steel under elastic deformation. Proceedings of the International Conference on Solid-Solid phase transformation in inorganic materials (Avignon), 2010.

**PROJECT AIM**

-

**PROGRESS**

A paper (Maizumkar, Bruining, Vermolen) was accepted in the Journal of the Society of Petroleum Engineers. The paper deals with a model for stress enhanced diffusion in porous media. Further, a paper (van Wijngaarden, Vermolen, Vuik, van Meurs) on modeling bacterial fortification of soils was accepted in Transport in Porous Media. Another paper (van Wijngaarden, Vermolen, Vuik, van Meurs) appeared in the Enumath 2009 conference proceedings. At this moment, a model for the bacterial adhesion in porous media is developed.

**DISSERTATIONS**

-

**SCIENTIFIC PUBLICATIONS**

1. W.K.van Wijngaarden, F.J.Vermolen, G.A.M.van Meurs, C.Vuik. Modeling the new soil improvement method biogrout: extension to 3D, Enumath Proceedings, Springer, 2010.

**PROJECTLEADERS**

F.J Vermolen, C Vuik

**RESEARCHTHEME**

Complex dynamics of fluids

**PARTICIPANTS**

F. Vermolen, C. Vuik, J. Bruining, P.L.J. Zitha, W.H. van Wijngaarden

**COOPERATIONS**

-

**FUNDED**

TUD/ Applied Earth Sciences, TUE University	50%
FOM	-
STW	-
NWO Other	-
Industry	50%
TNO	-
GTI	-
EU	-
Scholarships	-

**START OF THE PROJECT**

2000

**INFORMATION**

F.J Vermolen

015 278 7298

F.J.Vermolen@tudelft.nl

<http://ta.twi.tudelft.nl/users/vermolen>



Prof.dr.ir. AW Heemink

The central research direction of the group is the mathematical modeling of physical phenomena using (partial) differential equations. The research is application driven and includes the modeling phase, analysis of the model and the numerical implementation of the model. The focus is now more and more on the research themes:

**INVERSE MODELING AND DATA ASSIMILATION**

Data assimilation methods are used to combine the results of a large scale numerical model with the measurement information available in order to obtain an optimal reconstruction of the dynamic behavior of the model state. Many data assimilation schemes are based on solving the Euler-Lagrange equations. A recursive algorithm to solve this two-point boundary value problem can be derived and results in the well-known Kalman filtering algorithm. Variational data assimilation is also a powerful method, but requires the implementation of the adjoint (of the tangent linear approximation) of the numerical model. In a series of externally funded PhD projects the mathematical algorithms have been developed and applied in a number of real life applications:

- Tidal flow models (funding: Rijkswaterstaat)
- Atmospheric-chemistry modeling (funding: NWO, TNO, RIVM).
- Oil reservoir modeling (Funding: Shell, TNO).

**PERTURBATION METHODS FOR PARTIAL DIFFERENTIAL EQUATIONS**

The main focus within this theme is to develop perturbation methods to analyse initial value problems and initial-boundary value problems for partial differential equations. The applications are in a variety of fields, such as: the wind flow (or rain-wind) induced oscillations of bridges, high-rise buildings, or of overhead power transmission lines; the vibrations of conveyor belts; and the morphodynamics in tidal embayments.

**HIGH PERFORMANCE COMPUTING AND PARALLEL ALGORITHMS**

This research theme aims to design efficient and scalable parallel algorithms and apply high performance computing technology to applications, such as the storm surge forecasting and pollutant transport in North Sea or rivers. Domain decomposition and grid partitioning is an effective approach for parallel simulation of models described by partial differential equations. Sparse matrices typically occur in numerical simulation of problems described by partial differential equations. One of our research focus is on designing parallel algorithms for solving sparse matrix systems. Lagrangian models, often also called particle models, for transport problems in coastal waters, can deal with steep gradients of concentration. Because the movements of the particles are largely independent from each other, so particle models are very suited for parallel and distributed computing. We have developed parallel models for transport problems of the Dutch coastal water (e.g., Wadden sea). Currently, a particle model with adaptive time steps is being developed, besides the derivation of the numerical scheme the additional challenge is to maintain a good load balance in an adaptive scheme. Grid computing is the next step of development in high performance computing.

**PROJECT AIM**

Large scale numerical models are often used for prediction problems. These models however are however far from perfect. The model predictions can be improved by assimilating measurements into the model using a Kalman filter. A serious problem with this approach is that the standard filter algorithm imposes a very large burden on the computer. In order to obtain a computationally efficient filter, simplifications have to be introduced. Model reduction is a corner stone in developing sub-optimal scheme's. In this project new sub optimal algorithms to solve large scale Kalman filtering problems are developed.

**PROGRESS**

We have developed and applied new filter algorithms in the large scale atmospheric-chemistry transport model EUROS of RIVM to reconstruct the Ozone distribution in the atmosphere. We also developed a model reduction methodology for large scale numerical groundwater flow models in corporation with TNO. New PhD projects around the theme "Smart Wells" in corporation with the faculty CiTG, MIT and Shell have started. In these PhD project we will develop and apply model reduction and filtering techniques for assimilating data into multi-phase flow models in order to solve reservoir engineering problems. New application areas are also ecological coastal sea models and morphodynamic models.

**DISSERTATIONS**

1. A.L. Barbu, Ensemble based data assimilation schemes for atmospheric chemistry models., 2010.
2. N. van Velzen, A generic Software Framework for Data Assimilation and Model Calibration, 2010.

**SCIENTIFIC PUBLICATIONS**

1. An Efficient Weak-Constraint Gradient-Based Parameter-Estimation Algorithm Using Representer Expansions. Author(s): Rommelse JR, Jansen JD, Heemink AW. Source: SPE JOURNAL, Volume: 15, Issue: 1, Pages: 18-30, Published: MAR 2010 .
2. Non-linear wave data assimilation with an ANN-type wind-wave model and Ensemble Kalman Filter (EnKF). Author(s): Zamani A, Azimian A, Heemink A, et al.Source: APPLIED MATHEMATICAL MODELLING, Volume: 34, Issue: 8, Pages: 1984-1999, Published: AUG 2010 .

**PROJECTLEADERS**

AW Heemink

**RESEARCHTHEME**

Mathematical and computational methods for fluid flow analysis

**PARTICIPANTS**

R. Hanea, U.M. Altaf, M.P. Kaleta, N.van Velzen,, M. Verlaan, A.W. Heemink, I. Garcia, J.C. Pelc, C. Maris, S. Szklarz

**COOPERATIONS**

Deltares, RIVM, Shell, MIT, TNO, Vortech

**FUNDED BY**

Deltares, Shell, TNO, NWO

UNIVERSITY	10%
NWO Other	10%
Industry	20%
TNO	30%
GTI	20%
Scholarships	10%

**START OF THE PROJECT**

2001

**INFORMATION**

AW Heemink

015 278 5813

A.W.Heemink@tudelft.nl

<http://mathematicalphysics.ewi.tudelft.nl>

tudelft.nl

**PROJECTLEADERS**

AW Heemink

**RESEARCHTHEME**

Mathematical and computational methods for fluid flow analysis

**PARTICIPANTS**

P. Wilders, A.W. Heemink, M.A. Badri

**COOPERATIONS**

Deltares, Isfahan University

**FUNDED**

EEMCS, Isfahan University

UNIVERSITY 100%

NWO Other -

Industry -

TNO -

GTI -

Scholarships -

**START OF THE PROJECT**

1999

**INFORMATION**

P Wilders

015 278 7291

p.wilders@tudelft.nl, [http://](http://mathematicalphysics.ewi.tudelft.nl)

[mathematicalphysics.ewi.tudelft.nl](http://mathematicalphysics.ewi.tudelft.nl)

**PROJECT AIM**

Our aim is to apply and develop flexible numerical methods for transport applications in real-life large-scale environmental studies.

**PROGRESS**

The study of oil spill modeling for the Persian Gulf has been continued. A report describing a simplified flow model has been prepared. Oil spill simulations have been done and a report presenting the results is in progress..

**DISSERTATIONS**

-

**SCIENTIFIC PUBLICATIONS**

-

**PROJECT AIM**

The main focus within this project is to develop and to apply perturbation methods to analyze initial value problems and (initial)boundary value problems for partial differential equations. The applications are in a variety of fields, such as: the wind or rain-wind induced oscillations of elastics structures (such as bridges, high-rise buildings, and overhead power transmission lines); the vibrations of conveyor belts; the morphodynamic evolution of coastal systems (such as beaches, and estuaries); and the dynamics of polymers in shear flow.

**PROGRESS**

In 2010 the applicability of different types of perturbation methods was investigated. For problems with boundary damping, for nonselfadjoint problems, for weakly nonlinear problems, and for problems with variable coefficients all kinds of computational aspects have been studied by using perturbation methods, methods from dynamical system theory, numerical methods, and stochastic methods.

**DISSERTATIONS**

-

**SCIENTIFIC PUBLICATIONS**

1. On the forced vibrations of an oscillator with a periodically time-varying mass, WT van Horssen, OV Pischansky, and JLA. Dubbeldam. *Journal of Sound and Vibrations*, 329, pp. 721-732, 2010.
2. On asymptotic approximations of first integrals for second order difference equation, M Rafei, and WT van Horssen. *Nonlinear Dynamcis*, 61, pp 535-551, 2010.
3. The effect of tidal asymmetry and temporal settling lag on sediment trapping in tidal estuaries, AS Chernetsky, HM Schuttelaars, SA Talke. *Ocean Dynamics*, volume 60, issue 5, pp 1219-1241, 2010.
4. Modeling equilibrium bed profiles of short tidal embayments, MC ter Brake, HM Schuttelaars. *Ocean Dynamics*, volume 60, issue 2, pp 183-204, 2010.
5. Effect of bottom stress formulation on modelled flow and turbidity maxima in cross-sections of tide-dominated estuaries, GP Schramkowski, HE de Swart, HM Schuttelaars. *Ocean Dynamics*, volume 60, issue 2, pp 205-218, 2010.

**PROJECTLEADERS**

AW Heemink

**RESEARCHTHEME**

Mathematical and computational methods for fluid flow analysis

**PARTICIPANTS**

W.T. van Horssen, H.M. Schuttelaars, J.L.A.Dubbeldam, M. Rafei, M.C. ter Brake, A. Chernetsky, O.V. Pischans'kyy, S.H. Sandilo

**COOPERATIONS**

-

**FUNDED BY**

UNIVERSITY	80%
NWO Other	-
Industry	20%
TNO	-
GTI	-
Scholarships	-

**START OF THE PROJECT**

2003

**INFORMATION**

WT van Horssen  
015 278 3524  
W.T.vanHorssen@tudelft.nl  
<http://math.ewi.tudelft.nl>

**PROJECT LEADERS**

AW Heemink

**RESEARCH THEME**

Mathematical and computational methods for fluid flow analysis

**PARTICIPANTS**

H.X. Lin, S.M. Xu

**COOPERATIONS**Tsinghua University, China,  
GUCAS, China**FUNDED**

EU

UNIVERSITY 50%

NWO Other -

Industry 25%

TNO -

GTI 25%

Scholarships -

**START OF THE PROJECT**

2005

**INFORMATION**

HX Lin

015 278 7229

H.X.Lin@tudelft.nl

<http://mathematicalphysics.ewi.tudelft.nl>**PROJECT AIM**

The research aims at the design and implementation of high performance and parallel algorithms for sparse matrix computations. The applicability and limitations of the grid computing technology will also be investigated.

**PROGRESS**

In the project financed by the EU on the application of Grid Computing, the research focuses on power flow simulation of large electrical power systems. Work on multi-level preconditioning methods and Jacobian-free preconditioned Krylov type methods are currently under study for power flow analysis. In recent years, GPU (General-purpose graphical units) has been increasingly applied as accelerators for number crunching computational problems, we have studied the problem of optimization of the sparse-matrix operations (SpMV) on GPUs.

**DISSERTATIONS**

-

**SCIENTIFIC PUBLICATIONS**

1. Lin, H.X., et al (eds.), Proceedings of Euro-Par 2009 Parallel Processing Workshops, Lecture Notes in Computer Science LNCS volume 6043, Springer-Verlag, Berlin Heidelberg 2010.
2. Xu, S.M., Lin, H.X., Xue, W., Sparse Matrix-Vector Multiplication Optimizations based on Matrix Bandwidth Reduction using NVIDIA CUDA. Proceedings of the 9th international symposium on distributed computing and applications to business, engineering and science, Q. Guo, Y. Guo (eds.), IEEE Computer Society CPS, Hong Kong, 10-12 August 2010. pp. 609-614.
3. Zhou, J., Luo, T.J., Lin, H.X., A novel recommendation system with collective intelligence, Web Society (SWS), Proceedings of the 2010 IEEE 2nd Symposium on Web Society, Beijing, China, 16-17 Aug. 2010.







Prof.dr.ir. HEA van den Akker



Prof.dr.ir. CR Kleijn



Prof.dr.ir. RAWM Henkes



Prof.dr.DJEM Roekaerts



Prof.dr.AP Siebesma



Prof.dr. RF Mudde



Prof.dr.H Jonker



Prof.dr.S Sundaresan

The Department of Multi-Scale Physics (MSP) is dealing with Industrial and Environmental Processes. MSP aims at a better understanding, a better description and - especially in industry - a better control of these processes. MSP wishes to contribute in this way to more sustainable industrial processes and a more sustainable earth.

The research interests at MSP are organized around five themes. These themes are intended to focus and communicate the research activities of the Department and are in no way indicative of a further subdivision. People in the department may move from one theme to another from time to time, depending on developments in interests. The themes and the contact persons for each theme are:

- Clouds, Climate and Air Quality (prof. Harm Jonker)
- Computational Reactor Engineering (prof. Harry van den Akker, head of department)
- Reactive Flows & Explosions (prof. Dirk Roekaerts)
- Thermal & Materials Processes (prof. Chris Kleijn)
- Multi-Phase Flows (prof. Robert Mudde)

We consider flow and transport phenomena over a wide range of time and length scales in their mutual dependence. E.g. we study the interaction of molecular transport of heat and mass, chemical reactions, turbulent eddies, bubbles, drops and particles, and flow and convective transport at the scale of the vessel or at a long range. To do so we exploit a wide variety of advanced computational and experimental tools.

The type of industrial processes we have expertise about comprises plants of any commercial scale in which liquids, gases and solids are processed and manufactured. Our expertise relates to the fluid flow aspects and the heat and mass transport phenomena vital to such processes.

Operations such as mixing and separation processes, combustion, heating and cooling, coating, deposition and precipitation processes, absorption and adsorption, and chemical processes are among our themes of research and teaching. Examples of such plants and processes are abundantly present in the process industries (chemicals, food, pharmaceuticals), but also in the oil and gas industry and in the energy sector (biomass, nuclear, solar). A special topic of interest, associated with the public domain as well as with industrial processes, concerns safety and the risks of explosions.

Many environmental processes have much in common with industrial processes as the same flow and transport phenomena and concepts are at the basis of both. In particular we are dealing with are the life cycle of clouds and the dispersion of pollutants in the environment (air quality).

Clouds play a crucial role in climate and the response of clouds in a changing climate is one of the most pressing unknowns. Therefore we do fundamental research on cloud dynamics and cloud microphysics to improve parameterizations in weather and climate models, using detailed numerical simulation, laboratory experiments, analysis of aircraft, and satellite observations.

**PROJECT AIM**

A realistic representation of deep cumulus clouds remains one of the most challenging problems in atmospheric modeling. Numerical Weather Prediction and climate models, in which deep convection is parametrized, tend to predict the onset of deep convection too early during the day. We will investigate the transition from shallow clouds to deep convection using the Dutch Atmospheric Large Eddy Simulation (DALES) model. The simulation results of DALES will be used to determine the relative roles of gradual moistening of the cloud layer and the organisation of the boundary layer below cloud base.

**PROGRESS**

Recent work has focused on the influence of the behavior of the layer below cloud base on the development of deep convection. In particular, the effect of evaporation of rain below cloud base has been investigated by looking into the sensitivity to changes in the microphysics parameterization, as well as using virtual experiments in which the behavior of the subcloud layer was modified. It appears that the strength of evaporation is crucial for the development of deep convection and precipitation extremes. A journal paper about this work is currently being written, which is partly based on our recent conference paper (S.J. Böing, H. J. J. Jonker, A. P. Siebesma, and W. W. Grabowski, "Influence of Subcloud-layer Structures on the Transition to Deep Convection", 19th Symposium on Boundary Layers and Turbulence, American Meteorological Society, 2010).

**DISSERTATIONS**

-

**SCIENTIFIC PUBLICATIONS**

-

**PROJECT LEADERS**

HJJ Jonker, AP Siebesma

**RESEARCH THEME**

Complex dynamics of fluids

**PARTICIPANTS**

SJ Böing, HJJ Jonker, AP Siebesma,  
SR de Roode

**COOPERATIONS**

KNMI, Dr. W. Grabowski (NCAR,  
Boulder, Colorado, U.S.A)

**FUNDED**

TU Delft	
University	100%
FOM	-
STW	-
NWO Other	-
Industry	-
TNO	-
GTI	-
EU	-
Scholarships	-

**START OF THE PROJECT**

2009

**INFORMATION**

S Böing  
015 278 3478  
s.j.boing@tudelft.nl  
<http://www.msp.tudelft.nl/>

# A LABORATORY EXPERIMENT TO STUDY THE EFFECT OF TURBULENCE ON DROPLET GROWTH AND SIZE DISTRIBUTIONS IN CLOUDS

## PROJECT LEADERS

HJJ Jonker, M Tummers

## RESEARCH THEME

Complex dynamics of fluids

## PARTICIPANTS

T Chatterjee, HJJ Jonker,  
M Tummers, R Mudde, L Portela

## COOPERATIONS

Prof.Dr.J.Hunt (J.M.Burgers Center  
for Fluid Mechanics & University  
College London ), Dr. W.Grabowski  
(NCAR, Boulder,Colorado,U.S.A)

## FUNDED

NWO/ALW	
University	-
FOM	-
STW	-
NWO Other	100%
Industry	-
TNO	-
GTI	-
EU	-
Scholarships	-

## START OF THE PROJECT

2007

## INFORMATION

T Chatterjee  
015 278 3478  
T.Chatterjee@tudelft.nl  
www.msp.tudelft.nl/

## PROJECT AIM

The aim of the project is to increase the understanding of cloud microphysics, in particular the effect of turbulence on droplet growth and coalescence in convective clouds which affect both the optical properties of clouds and the formation of precipitation. Issues like preferential concentration, turbulence enhanced settling velocities and turbulence enhanced collision coalescence will be addressed. Phase Doppler Anemometry (PDA) is to be used for simultaneously measuring droplet velocities and droplet size distributions.

## PROGRESS

The experimental set up has been designed and implemented to produce droplets and to study the behavior in a turbulent environment. During the last year, several sets of measurements have been carried out with Phase Doppler Anemometry (PDA) to investigate and quantify the role of turbulence on the droplet collision rate. By traversing the nozzle, droplet velocities and droplet size statistics can be obtained in different parts of the flow. On comparing these distributions at different positions, the droplet growth by collisions can be studied as well as the effects of evaporation by comparing the results for an open system with a closed one. This helped us in drawing up some inferences. In addition, measurements were done using a PIV system producing spatial information of the turbulent flow velocities combined with droplet distributions. Multi-fractal analysis is performed of droplet images and post processing of the velocity data is carried out to establish a relation between flow and droplet clustering.

## DISSERTATIONS

-

## SCIENTIFIC PUBLICATIONS

-

# EDDY COVARIANCE OBSERVATIONS OF METHANE AND NITROUS OXIDE: TOWARDS MORE ACCURATE ESTIMATES FROM ECOSYSTEMS

## PROJECT AIM

The main objective is to check the hypothesis whether atmospheric eddy covariance flux measurements can substantially contribute to a decrease in the uncertainty of the annual emission estimates of methane (CH<sub>4</sub>) and nitrous oxide (N<sub>2</sub>O) from ecosystems compared to estimates based on chambers only. This hypothesis will be tested using continuous field measurements, laboratory experiments and literature studies.

## PROGRESS

The project was ended in 2010. Consequently, the work was mainly related to writing publications (see below) and to presentations. Presentations were given at several international conferences, e.g. NitroEurope meeting (Sweden), chamber workshop (Finland), NCGG-5 conference (Wageningen) and iLEAPS conference (Australia). A dissertation was written and was successfully defended in June 2010. The main conclusion of the thesis is that eddy covariance flux measurements can substantially contribute to a decrease in the annual estimates of CH<sub>4</sub> and N<sub>2</sub>O from ecosystems. If appropriate data processing methods are used and data coverages above 80% are attained, uncertainties in annual balances could be even smaller than 10%. The emissions of both gases are really significant in comparison to the emission of CO<sub>2</sub> at our study site a managed peat area. They contribute for two-third to the total terrestrial greenhouse gas emission.

## DISSERTATIONS

1. Eddy covariance observations of methane and nitrous oxide emissions: Towards more accurate estimates from ecosystems. Delft University; June 2010.

## SCIENTIFIC PUBLICATIONS

1. Kroon, PS; Schrier-Uijl, AP; Hensen, A; Veenendaal, EM; Jonker, HJJ. Annual balances of CH<sub>4</sub> and N<sub>2</sub>O from a managed fen meadow using eddy covariance flux measurements; EUROPEAN JOURNAL OF SOIL SCIENCE, 2010, 61, 773-784.
2. Kroon, PS; Vesala, T; Grace, J. Flux measurements of CH<sub>4</sub> and N<sub>2</sub>O exchanges AGRICULTURAL AND FOREST METEOROLOGY, 2010, 150,745-747.
3. Kroon, PS; Schuitmaker, A; Jonker, HJJ; Tummerts, MJ; Hensen, A; Bosveld, FC. An evaluation by laser Doppler anemometry of the correction algorithm based on Kaimal co-spectra for high frequency losses of EC flux measurements of CH<sub>4</sub> and N<sub>2</sub>O. AGRICULTURAL AND FOREST METEOROLOGY, 2010, 150, 794-805.
4. Kroon, PS; Hensen, A; Jonker, HJJ; Ouwersloot, HG; Vermeulen, AT; Bosveld, FC. Uncertainties in eddy covariance flux measurements assessed from CH<sub>4</sub> and N<sub>2</sub>O observations. AGRICULTURAL AND FOREST METEOROLOGY, 2010, 150, 806-816.
5. Schrier-Uijl, AP; Kroon, PS; Hensen, A; Leffelaar, PA; Berendse, F; Veenendaal, EM. Comparison of chamber and eddy covariance-based CO<sub>2</sub> and CH<sub>4</sub> emission estimates in a heterogeneous grass ecosystem on peat. AGRICULTURAL AND FOREST METEOROLOGY. 2010, 150, 825-831.
6. de Roode, SR; Bosveld, FC; Kroon, PS. Dew Formation, Eddy-Correlation Latent Heat Fluxes, and the Surface Energy Imbalance at Cabauw During Stable Conditions. BOUNDARY-LAYER METEOROLOGY. 2010, 135, 369-383.
7. Schrier-Uijl, AP; Kroon, PS; Leffelaar, PA; van Huissteden, JC; Berendse, F; Veenendaal, EM. Methane emissions in two drained peat agro-ecosystems with high and low agricultural intensity. PLANT AND SOIL, 2010, 329, 509-520.

## PROJECTLEADERS

A Hensen (ECN), HJJ Jonker

## RESEARCHTHEME

Complex dynamics of fluids

## PARTICIPANTS

PS Kroon (TU Delft & ECN),  
HJJ Jonker (TU Delft), A Hensen (ECN), AT Vermeulen (ECN), AP Schrier Uijl (WU), MJ Tummerts (TU Delft), A Schuitmaker (TU Delft), HG Ouwersloot (TU Delft & WU), WH van 't Veen (ECN) and FC Bosveld (KNMI)

## COOPERATIONS

Wageningen University (the Netherlands), University of Amsterdam (the Netherlands), KNMI (the Netherlands), Aerodyne Research Inc. (Boston, USA)

## FUNDED

Dutch research program Climate Changes Spatial Planning ([www.klimaatvoorruiimte.nl](http://www.klimaatvoorruiimte.nl))  
European CarboEurope program ([www.carboeurope.org](http://www.carboeurope.org))

Energy research Centre of the Netherlands  
University -  
FOM -  
STW -  
NWO Other -  
Industry 100%  
TNO -  
GTI -  
EU -  
Scholarships -

## START OF THE PROJECT

2005

## INFORMATION

P Kroon  
0224 564062  
[p.kroon@ecn.nl](mailto:p.kroon@ecn.nl)

**PROJECT LEADERS**

SR de Roode, HJJ Jonker,  
AP Siebesma

**RESEARCH THEME**

Complex dynamics of fluids

**PARTICIPANTS**

J van der Dussen, SJ Böing,  
E Jones, SR de Roode, HJJ Jonker,  
AP Siebesma

**COOPERATIONS**

KNMI, + 12 other EU partners  
involved in EUCLIPSE

**FUNDED**

EU	
University	50%
FOM	-
STW	-
NWO Other	-
Industry	50%
TNO	-
GTI	-
EU	100%
Scholarships	-

**START OF THE PROJECT**

2010

**INFORMATION**

J van der Dussen  
015 278 4720  
J.J.vanderDussen@tudelft.nl  
www.msp.tudelft.nl/

**PROJECT AIM**

The cloud response due to the enhanced greenhouse effect remains the largest source of uncertainty in climate model projections of a future climate. The EU-funded Cloud Intercomparison, Process Study & Evaluation Project (EUCLIPSE) aims to reduce the uncertainty in the representation of cloud processes and feedbacks in the new generation of Earth System Models (ESMs). This sub-project will use the Dutch Atmospheric Large-Eddy Simulation model to study in detail turbulent flows in cloudy atmospheres. Central question is how the vertical atmospheric stability controls the spatial coverage and depth of low clouds like stratocumulus and shallow cumulus.

**PROGRESS**

A proposal for a large eddy simulation model intercomparison was arrived at, based on the observations of a stratocumulus to cumulus transition. Revisions to that description have been made based on preliminary results and remarks by other participants and based on many sensitivity experiments. The final case has been released and simulated, the results of other participants are due by the end of the month. The setup to be used for Single Column Models has also been released. No results have been submitted yet. Furthermore, several large simulations have been performed for a similar intercomparison case, organised by Irina Sandu. The final results of the reference case have been submitted, while the results of her second case will finish this month (February). A different radiation scheme, necessary for the participation in the CGILS experiment has been included in the existing large eddy simulation model.

**DISSERTATIONS**

-

**SCIENTIFIC PUBLICATIONS**

-

# HIGH RESOLUTION REGIONAL CLIMATE MODELING OF CONVECTION AND PRECIPITATION OVER THE NETHERLANDS

## PROJECT AIM

Operations at the Amsterdam airport Schiphol are very sensitive to critical weather conditions, like fog, low level clouds, heavy rainfall and strong winds, and sudden changes in these conditions. Changes in our future climate will have its impact on the variability of the weather at Schiphol Airport and on the frequency and intensity at which extreme events will occur. The objective of this project is to evaluate and to improve the capability of a new high resolution weather forecast model HARMONIE to represent and resolve mesoscale systems over the Netherlands such as: isolated convective cells, cold-air outbreaks, squall lines and the precipitation associated with these systems.

## PROGRESS

HARMONIE runs for two deep convection IMPACT cases and two stratocumulus cases have been completed, and analysis is well underway. HARMONIE results have been compared to HIRLAM model results, which are the current standard used at Schiphol. HARMONIE has shown some improvement over HIRLAM in predicting precipitation. An analysis of the unusually rainy August 2006 is also begun in order to investigate the effect of a high sea surface temperature on precipitation in the Netherlands. Preliminary results agree fairly well with observations.

## DISSERTATIONS

-

## SCIENTIFIC PUBLICATIONS

-

## PROJECT LEADERS

AP Siebesma, SR de Roode, HJJ Jonker

## RESEARCH THEME

Complex dynamics of fluids

## PARTICIPANTS

E Jones, J Van der Dussen, SJ Böing, SR de Roode, HJJ Jonker, AP Siebesma

## COOPERATIONS

KNMI, WUR

## FUNDED

Kennis voor Klimaat	
University	-
FOM	-
STW	-
NWO Other	-
Industry	-
TNO	-
GTI	100%
EU	-
Scholarships	-

## START OF THE PROJECT

2010

## INFORMATION

S de Roode  
015 278 4720  
S.R.deRoode@tudelft.nl  
[www.msp.tudelft.nl/](http://www.msp.tudelft.nl/)

**PROJECT LEADERS**

L Portela, R Mudde, HJJ Jonker

**RESEARCH THEME**

Complex dynamics of fluids

**PARTICIPANTS**

V Perrin, L Portela, R Mudde,  
HJJ Jonker

**COOPERATIONS**

-

**FUNDED**

FOM

University -

FOM 100%

STW -

NWO Other -

Industry 50%

TNO -

GTI -

EU -

Scholarships -

**START OF THE PROJECT**

2010

**INFORMATION**

V Perrin

015 278 9174

v.e.perrin@tudelft.nl

www.msp.tudelft.nl/

**PROJECT AIM**

The focus will be on the evolution of droplet size distributions under a sharp gradient in the mean gas velocity, the droplet concentration and the background humidity. The goal of this project is to understand the interplay between the turbulence dynamics, and the droplet distribution. The two key questions to be addressed are: What is the influence of shear in the mixing layer on the droplet distribution and dispersion, droplet collisions and coalescence efficiency. How are the dispersion, collision frequency and coalescence efficiency influenced by the orientation of the mixing layer with respect to gravity?

**PROGRESS**

Candidate (Vincent Perrin) has been selected and hired.

**DISSERTATIONS**

-

**SCIENTIFIC PUBLICATIONS**

-

## PREDICTIVE LARGE-EDDY-SIMULATIONS: IMPROVING PRECIPITATION FORECASTS

### PROJECT AIM

The current generation of weather prediction models is, not able to predict the location, timing and intensity of severe rainfall with acceptable accuracy. Fundamental knowledge concerning the rainfall formation process and is lacking, while prediction models do not (and will not in the near future) have the capacity to resolve the wide range of scales involved in raincloud evolution. This program aims to improve prediction accuracy by using Large Eddy Simulations (LES) to perform the needed high-resolution calculations and integrate this in large-scale prediction models to create a multi-scale model hierarchy. Excessive computational requirements always forced reasonable domain LES to run on supercomputing facilities, whose batch queuing protocols inhibit interaction. This program aims to solve this using Graphical Processing Units (GPUs) to provide the necessary computational power while running on a single PC.

### PROGRESS

The group's Atmospheric Large Eddy Simulation has been ported to be performed on the computer's GPU, with the help of the Mathematics&Computer Sciences group. The GPU-implemented version has been verified with the help of LES intercomparison case studies.

### DISSERTATIONS

-

### SCIENTIFIC PUBLICATIONS

-

### PROJECTLEADERS

HJJ Jonker, AP Siebesma

### RESEARCHTHEME

Complex dynamics of fluids

### PARTICIPANTS

J Schalkwijk, HJJ Jonker,  
AP Siebesma, RAJ Neggers

### COOPERATIONS

KNMI

### FUNDED

TUD/KNMI	
University	50%
FOM	-
STW	-
NWO Other	-
Industry	50%
TNO	-
GTI	-
EU	-
Scholarships	-

### START OF THE PROJECT

2010

### INFORMATION

J Schalkwijk

015 278 9174

J.Schalkwijk@tudelft.nl

[www.msp.tudelft.nl/](http://www.msp.tudelft.nl/)



### PROJECT LEADERS

HJJ Jonker, S Kenjeres,  
SR de Roode

### RESEARCH THEME

Complex dynamics of fluids

### PARTICIPANTS

P Schrijvers, S Kenjeres,  
SR de Roode, HJJ Jonker

### COOPERATIONS

WUR, TNO

### FUNDED

Kennis voor Klimaat  
University -  
FOM -  
STW -  
NWO Other -  
Industry -  
TNO -  
GTI 100%  
EU -  
Scholarships -

### START OF THE PROJECT

2010

### INFORMATION

P Schrijvers  
015 278 9174  
P.J.C.Schrijvers@tudelft.nl  
www.msp.tudelft.nl/

### PROJECT AIM

The aim of this project is to simulate climate adaptation in neighbourhoods and districts of cities, with a main emphasis on heat. Issues like temperature effects and surface heat balances for building facades are taken into account. The model is coupled to a meso-scale model for large scale effects of the urban heat island effect.

### PROGRESS

A new script has been written to convert complex topographies in any number of square blocks. First complex topographies are simulated.

### DISSERTATIONS

-

### SCIENTIFIC PUBLICATIONS

-

**PROJECT AIM**

Stochastic parameterization is an exciting new topic at the intersection of applied mathematics and climate science. Because of the shortcomings of currently used, deterministic parameterizations and the pivotal role of clouds and convection in climate change uncertainties, stochastic methods for convection parameterization have become a hot research theme in recent years. In this project we will develop a stochastic approach to convection parameterization, combining new mathematical ideas on hybrid stochastic-deterministic models and multiscale systems with results from Large Eddy Simulation (LES) of atmospheric moist convection. The overall goal is to formulate a stochastic parameterization scheme that is suitable for practical use in climate models, and to evaluate the impact of such a scheme on cloud-climate feedbacks.

**PROGRESS**

A first purely stochastic model based on LES data has been constructed. The model works fine for the steady shallow cumulus case BOMEX. This model has also been successfully tested for the shallow cumulus case ARM in which a diurnal cycle is included. At this moment the model only works for these 2 specific cases, because it has been designed with the help of LES data based on these cases. Of course, the model should perform under more general circumstances. To achieve this, we will use an existing deterministic parameterization scheme and try to combine it with our stochastic scheme.

**DISSERTATIONS**

-

**SCIENTIFIC PUBLICATIONS**

-

**PROJECT LEADERS**

D Crommelin (CWI), AP Siebesma, HJJ Jonker

**RESEARCH THEME**

Complex dynamics of fluids

**PARTICIPANTS**

J Dorrestijn, D Crommelin (CWI), F Selten (KNMI), AP Siebesma, HJJ Jonker

**COOPERATIONS**

CWI, KNMI

**FUNDED**

NWO/ALW	
University	-
FOM	-
STW	-
NWO Other	100%
Industry	-
TNO	-
GTI	-
EU	-
Scholarships	-

**START OF THE PROJECT**

2010

**INFORMATION**

H Jonker  
 015 278 6157  
 H.J.J.Jonker@tudelft.nl  
 www.msp.tudelft.nl/

**PROJECT LEADERS**

C Kleijn, S Kenjeres

**RESEARCH THEME**

Complex dynamics of fluids

**PARTICIPANTS**

A Kidess, CR Kleijn, S Kenjeres

**COOPERATIONS**

Prof. Ian Richardson, Dr. Chuangxin Zhao (both TU Delft Materials Science & Engineering) University of Leicester; University College Dublin; University of Oxford, Norwegian Institute of Science and Technology; Royal Institute of Technology Stockholm; Ecole Polytechnique Federale de Lausanne; Corus UK; TWI; Frenzak; Poland Institute of Welding

**FUNDED**

EU FP7	
University	-
FOM	-
STW	-
NWO Other	-
Industry	-
TNO	-
GTI	-
EU	100%
Scholarships	-

**START OF THE PROJECT**

2009

**INFORMATION**

CR Kleijn  
015 278 2835  
C.R.Kleijn@TUDelft.NL  
www.msp.tudelft.nl

**PROJECT AIM**

The MINTWELD project aims to improve welding processes by using simulation models working on a range of length scales and knowledge gained from industrial experiments. Our contribution is to develop computational models for the prediction of the influence of hydrodynamics on the interface evolution in advanced welding processes.

**PROGRESS**

We are nearing completion of a software tool to predict laser welding processes. It's capabilities include the prediction of the transient flow of molten steel driven by thermocapillary forces, the movement of the liquid free surface as well as the heat distribution in the base metal and the final weld pool shape, both of which are highly dependent on the flow within the pool. Results demonstrating the influence of the free surface movement on the heat transfer have been presented at the 2nd European conference on microfluidics.

**DISSERTATIONS**

-

**SCIENTIFIC PUBLICATIONS**

1. Saldi, ZS, Kidess, A, Kenjeres, S, Kleijn, CR, Zhao, C & Richardson, IM. Marangoni driven free surface microflows in liquid weld pools. In S Colin & GL Morini (Eds.), Proceedings of the 2nd european conference on microfluidics (pp. 1-12). Toulouse.

## IMPROVED CONTINUOUS CASTING THROUGH ELECTROMAGNETIC FLOW CONTROL

### PROJECT AIM

The project aim is a validated flow solver for casting of liquid steel in the mould based on the OpenFOAM framework. This includes flow control by magnet fields (magnetohydrodynamics), free surface capturing (volume of fluid approach) and anisotropic turbulence (hybrid RANS/LES).

### PROGRESS

In the first three months of the project it was decided to use the OpenFOAM framework for this project. Three routes to computationally combine free surface flow and magnetic flow control are defined and its investigation is ongoing. Furthermore, the test cases for turbulence models have been defined, which are and will be used to test existing and newly developed models inside the OpenFOAM framework. Numerical simulations have been performed for the design of an experimental facility in a parallel project.

### DISSERTATIONS

-

### SCIENTIFIC PUBLICATIONS

-

### PROJECTLEADERS

CR Kleijn, S Kenjereš, M Tummers

### RESEARCHTHEME

Complex dynamics of fluids

### PARTICIPANTS

R Kalter, B Righolt, M Tummers,  
S Kenjereš, CR Kleijn

### COOPERATIONS

Tata Steel, ABB

### FUNDED

STW	
University	-
FOM	-
STW	88%
NWO Other	-
Industry	12%
TNO	-
GTI	-
EU	-
Scholarships	-

### START OF THE PROJECT

2010

### INFORMATION

B Righolt  
b.w.righolt@tudelft.nl

**PROJECT LEADERS**

CR Kleijn

**RESEARCH THEME**

Complex dynamics of fluids

**PARTICIPANTS**

D Ambesis, CR Kleijn

**COOPERATIONS**

TNO Defense and Security

**FUNDED**

TNO

University -

FOM -

STW -

NWO Other -

Industry -

TNO 100%

GTI -

EU -

Scholarships -

**START OF THE PROJECT**

2009

**INFORMATION**

CR Kleijn

015 278 2835

C.R.Kleijn@TUDelft.NL

www.msp.tudelft.nl

**PROJECT AIM**

The goal of this project is to develop predictive models for the protective behaviour and thermal comfort of Nuclear-Biological-Chemical protective textiles, with a special focus on chemical breakthrough. We study air flow, heat and mass transfer through the textile at multiple scales, ranging from that of the textile fibres and carbon particles to that of an entire person, in combination with the penetration of both gaseous and liquid toxic components.

**PROGRESS**

We have studied heat and mass transfer to single layers of thin parallel wires, and to single layers of small particles, as a function of open frontal area fraction, Reynolds, Prandtl and Schmidt numbers. We have deduced heat and mass transfer correlations for  $0.1 < Re < 100$ , and  $0.7 < Pr/Sc < 10$ , and we have evaluated the asymptotic behaviour for small and large  $Re$ . We have also studied the impact of non-regular arrangements of the wires or particles on heat and mass transfer, which was found to reduce heat and mass transfer by up to 30% at intermediate  $Re$ , whereas no influence was found for small and large  $Re$ .

**DISSERTATIONS**

-

**SCIENTIFIC PUBLICATIONS**

-

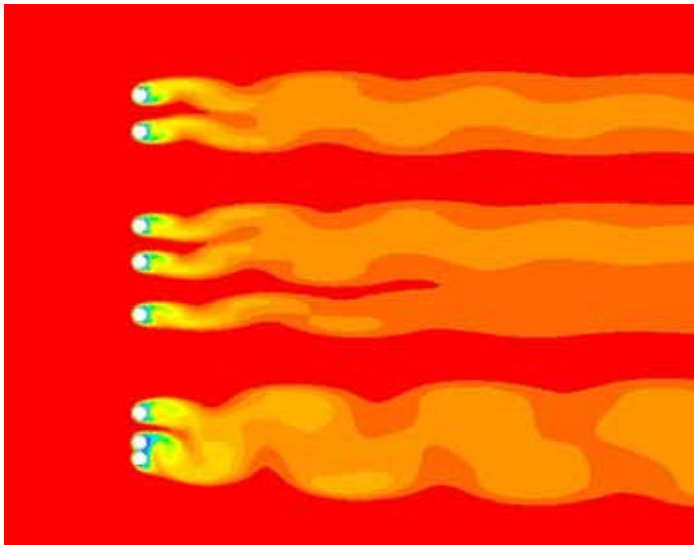

Flow and heat transfer around a disordered layer of parallel thin wires at  $Re=100$ ,  $Pr=0.7$  and an open frontal area fraction 0.8.

**PROJECT AIM**

Segmented flow is widely used in microreactor (Process-on-a-Chip and Lab-on-a-Chip) technology because of its high mass transfer, low axial dispersion and rapid micromixing. The generation and control of segmented flow in a single microchannel is well-established. Numbering up towards large-scale processing, however, required techniques for the stable and controlled distribution of segmented flows over networks of channels. As yet, techniques and fundamental understanding of such distributions are limited. In this project, we study the generation and transport of droplets and bubbles in microfluidic networks that comprise a large number of parallel microchannels. The aim is to understand how to form and distribute streams of bubbles or droplets in such networks.

**PROGRESS**

- A thesis proposal completed.
- The dynamics of the formation of bubbles and droplets in microfluidic T-junction was studied through 3-D numerical simulations using OpenFoam. The predicted sizes of created bubbles and droplets were in good agreement with our theoretical and experimental data.
- An improved dynamic contact angle model and improved algorithms to compute surface curvature have been implemented to improve the accuracy of our numerical code.

**DISSERTATIONS**

-

**SCIENTIFIC PUBLICATIONS**

1. Duong, HA, Steijn, V van, Portela, L, Kreutzer, MT & Kleijn, CR (2010). Numerical predictions of the size of bubbles and droplets created in microfluidic T-junctions. Proceedings of the 2nd European Conference on Microfluidics (pp. 1-7). Toulouse.

**PROJECT LEADERS**

CR Kleijn, MT Kreutzer, L Portela

**RESEARCH THEME**

Complex dynamics of fluids

**PARTICIPANTS**

Hoang Anh Duong

**COOPERATIONS**

TU Eindhoven (J.C. Schouten), Wageningen University (R. Boom), OSPT-IROP (DSM, Shell, DOW, Akzo-Nobel, Unilever, TNO)

**FUNDED**

STW, OSPT-IROP IROP (DSM, Shell, DOW, Akzo-Nobel, Unilever, TNO)

University	-
FOM	-
STW	-
NWO Other	75%
Industry	25%
TNO	-
GTI	-
EU	-
Scholarships	-

**START OF THE PROJECT**

2009

**INFORMATION**

CR Kleijn  
015 278 2835  
C.R.Kleijn@TUDelft.NL  
www.msp.tudelft.nl

H Anh Duong  
015 278 3210  
h.a.duong@tudelft.nl  
www.msp.tudelft.nl/

**The formation of bubbles in a microfluidic T-junction**



**The split-up of bubbles in a microfluidic T-junction**



**PROJECT LEADERS**

CR Kleijn, MT Kreutzer

**RESEARCH THEME**

Complex dynamics of fluids

**PARTICIPANTS**

M Musterd

**COOPERATIONS**

JM van Beek (UT), L. Lefferts (UT),  
Shell, DOW, ECN, Sulzer

**FUNDED**

DSTI

University -

FOM -

STW -

NWO Other -

Industry 100%

TNO -

GTI -

EU -

Scholarships -

**START OF THE PROJECT**

2010

**INFORMATION**

M Musterd

015 278 7084

m.musterd@tudelft.nl

www.msp.tudelft.nl/

**PROJECT AIM**

In this project we aim to develop a CFD model to predict multiphase flow in micro- and millifluidic channels under partial wetting conditions. The partial wetting condition introduces additional fluids-solid interactions, which have a significant influence on the flow behaviour due to the dominance of capillary forces. A quantitative understanding of the fluids-solid interactions is of importance to properly model the surface tension dominated multiphase flow. Therefore, the focus is on understanding and controlling the dynamics of the fluids-solid interface.

**PROGRESS**

This project started October 1st 2010 so only little progress can be reported on. We have started numerical investigations of the static shape of gas bubbles and liquid droplets in microfluidic systems. For this purpose we use Surface Evolver, a finite element solver, developed to find the shape of an interface that minimizes its energy under given constraints such as impenetrable walls, equilibrium contact angles and energy contributions other than surface energy (e.g. gravitational energy). First results suggest that the equilibrium shape bubbles/droplets in a microfluidic geometry accounts for a major part of the dynamics. The figure below shows an equilibrium interface shape in a T-junction for a given volume of the bubble/droplet.

**DISSERTATIONS**

-

**SCIENTIFIC PUBLICATIONS**

-

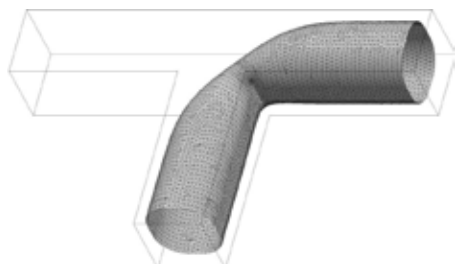

MODEL EXPERIMENTS ON IMPROVED CONTINUOUS STEEL CASTING  
THROUGH ELECTROMAGNETIC FLOW CONTROL

**PROJECT AIM**

The aim of the project is to provide a fundamental understanding of, and experimentally validated models for, the influence of electromagnetic fields on flow, turbulence and heat transfer in liquid steel during continuous casting. These insights and models will make it possible to design and to optimize new strategies for controlling steel casting processes, leading to significant energy savings, increased productivity and improved product quality.

**PROGRESS**

In October 2010 the project was started. So far work has been done on the design and implementation of a first experimental setup. This is a water model of a continuous casting mould. With this model, we want to record the flow field in the mould and this will be used in the design of the eventual setup.

**DISSERTATIONS**

-

**SCIENTIFIC PUBLICATIONS**

-

**PROJECT LEADERS**

CR Kleijn, M Tummers, S Kenjeres

**RESEARCH THEME**

Complex dynamics of fluids

**PARTICIPANTS**

R Kalter

**COOPERATIONS**

Tata Steel, ABB

**FUNDED**

Tata steel, ABB, STW

University -

FOM -

STW 71%

NWO Other -

Industry 29%

TNO -

GTI -

EU -

Scholarships -

**START OF THE PROJECT**

2010

**INFORMATION**

Rudi Kalter

015 212 82418

[www.msp.tudelft.nl](http://www.msp.tudelft.nl)



**PROJECT LEADERS**

CR Kleijn, S Kenjeres

**RESEARCH THEME**

Complex dynamics of fluids

**PARTICIPANTS**

Z Saldi, S Kenjeres, CR Kleijn

**COOPERATIONS**

Materials innovation institute (M2i), Chuangxin Zhao, MSc, Prof. Ian Richardson (both TU Delft Materials Science & Engineering), Tata Steel

**FUNDED**

Materials innovation institute (formerly Netherlands Institute for Metals Research)  
 University -  
 FOM -  
 STW -  
 NWO Other -  
 Industry 100%  
 TNO -  
 GTI -  
 EU -  
 Scholarships -

**START OF THE PROJECT**

2006

**INFORMATION**

Z Saldi  
 015 278 9111  
 z.saldi@tudelft.nl  
 www.msp.tudelft.nl

**PROJECT AIM**

To gain a fundamental understanding, through modeling & experiments, of the influence of hydrodynamics on the formation & structure of fusion laser spot weld pools.

**PROGRESS**

A 3D mathematical model describing the multiphase transport of mass, momentum, and energy in the weld pool subjected to a spot laser beam has been developed. The model also includes the evolution of latent heat to account for melting and solidification phase change. Moreover, the deformation of free surface between the weld pool and the surrounding gas phase is captured using the Volume of Fluid method. The model has been implemented in the open source CFD code OpenFOAM. The developed model is able to predict the weld pool free surface deformations and instabilities, which have also been observed experimentally. The simulation using free surface model results in a deeper weld pool in comparison with that obtained using a flat surface assumption. This explains the practice common in literature to artificially enhance thermal conductivity and viscosity in order to get good agreement with experiments.

**DISSERTATIONS**

-

**SCIENTIFIC PUBLICATIONS**

1. Zhao C.X., Kwakernaak C., Pan Y., Richardson I.M., Saldi Z., Kenjeres S., Kleijn C.R. (2010). The effect of oxygen on transitional Marangoni flow in laser spot welding. *Acta Materialia*, doi: 10.1016/j.actamat.2010.07.056.
2. Saldi Z, Kidess A, Kenjeres S, Kleijn C, Zhao C, Richardson I (2010), Marangoni driven free surface microflows in liquid metal weld pools, Proceedings of the 2nd european conference on microfluidics, 2010, Toulouse, December 8-10, 2010.
3. Zhao C.X., Richardson I.M., Song G.M., Pan Y., Kenjeres S., Saldi Z.S., Kleijn C.R., (2010). Unstable contact line spreading of liquid stainless steel, Triple lines in metals and ceramics-a symposium in honor of Nicolas Eustathopoulos, Center de Physique des Houches, France, May 25-28, 2010.

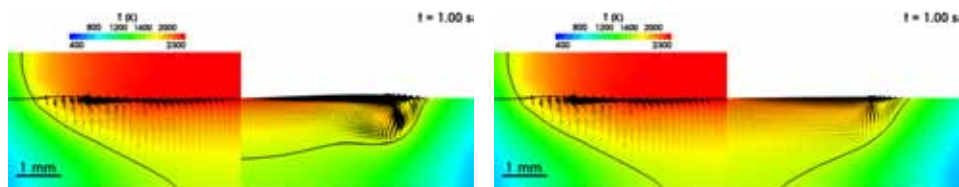

Weld pool cross section comparisons of 3-D free surface simulation (left hand sides in both columns) vs 2-D axisymmetric flat surface simulation. The latter with without (right hand side of left column) and with enhancement factor  $f = 3.7$  for thermal conductivity and viscosity (right hand side of right column).

# HYBRID RANS/LES SIMULATIONS OF TURBULENT FLOWS OVER HILLS AND COMPLEX URBAN AREAS WITH DISPERSION OF POLLUTANTS

## PROJECT AIM

This project is part of the long-term investigations at our Department of Multi Scale Physics aimed at the mathematical modeling and numerical simulations of environmental flows and turbulent dispersion. In this particular project we focus our investigation at the turbulent flows over complex terrains and urban areas (street canyons) partially covered with vegetation and with different sources of the passive scalar (point, line, area concentration source).

## PROGRESS

Several extensions of standard two-equation eddy-viscosity turbulence models have been investigated, which are expected to eliminate some well-known deficiencies of the standard models relevant for accurate predictions of environmental flows. These include effects of surface roughness through generalized wall functions, a redefined TKE production, a time-scale limiter and a hybrid RANS/LES approach. Another novelty is an efficient representation of blocked flow regions for mimicking built objects. The accuracy and robustness of these models in a structured non-orthogonal Navier-Stokes solver have been investigated. We simulated the flow and spreading of traffic pollution in urban street canyons at lab- and full-scale, and found good agreement with available measurements. Recently, we started to study flow and turbulence around the TU Delft campus. Also we tested few variants of the models that incorporate effects of trees on velocity and turbulence. Further investigations including a novel hybrid RANS/LES approach are currently under development.

## DISSERTATIONS

-

## SCIENTIFIC PUBLICATIONS

1. Kenjeres, S and ter Kuile, B. (2010), "Modelling and simulations of flow, turbulence and dispersion in urban areas with non-homogeneous vegetation", In C Dopazo (Ed.), Proceedings of the 8th International ERCOFTAC symposium on engineering turbulence modelling and measurements, pp. 170-175, Marseille, France.

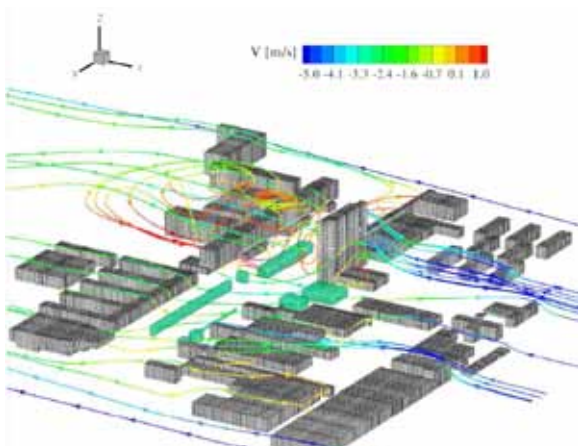

Flow patterns over TU Delft campus. Simulations with newly developed hybrid seamless RANS/LES approach, Kenjeres et al. (2010).

## PROJECT LEADERS

S Kenjeres, K Hanjalic, CR Kleijn

## RESEARCH THEME

Complex dynamics of fluids

## PARTICIPANTS

S Kenjeres, K Hanjalic, CR Kleijn

## COOPERATIONS

-

## FUNDED

TU Delft, KNAW	
University	100%
FOM	-
STW	-
NWO Other	-
Industry	-
TNO	-
GTI	-
EU	-
Scholarships	-

## START OF THE PROJECT

2001

## INFORMATION

S Kenjeres

015 278 3649

S.Kenjeres@tudelft.nl

www.msp.tudelft.nl

# EXPERIMENTAL AND NUMERICAL INVESTIGATIONS OF TURBULENT FLOWS OVER COMPLEX SURFACE WITH HEAT TRANSFER AND EMISSION OF PASSIVE SCALARS

## PROJECT LEADERS

S Kenjeres, CR Kleijn

## RESEARCH THEME

Complex dynamics of fluids

## PARTICIPANTS

S Kenjeres, R Von Rohr, C Wagner,  
S Kuhn

## COOPERATIONS

R Von Rohr, ETH Zurich

## FUNDED

ETH Zurich, TU Delft, ERCOFTAC,  
HPC-Europa

University 50%

FOM -

STW -

NWO Other -

Industry -

TNO -

GTI -

EU 50%

Scholarships -

## START OF THE PROJECT

2003

## INFORMATION

S Kenjeres

015 278 3649

S.Kenjeres@tudelft.nl

www.msp.tudelft.nl

## PROJECT AIM

This is a joint project between Dept. of Multi Scale Physics at the TU Delft and the Laboratory for Transport Processes and Reactions of Prof. von Rohr at ETH Zurich. The project addresses the combined experimental and numerical study of turbulent flows over complex surfaces with heat transfer and distribution of passive scalars. The final goal is to perform in parallel state-of-the-art experiments (stereo PIV, LIF, TLC) and numerical simulations (LES, hybrid RANS/LES, DES, RANS) for different wall configurations over a range of Reynolds numbers and intensities of the wall heat flux and scalar emissions.

## PROGRESS

Measurements of turbulent forced and mixed convection flow and heat transfer over two-dimensional sinusoidal heated walls for  $20 < Re < 30000$  and  $0 < Ri < 5000$  have been performed at ETH Zurich. The first sets of numerical simulations have been performed at TU Delft – including a newly developed 4-equation elliptic relaxation RANS model and LES with dynamical Smagorinsky model. Comparison between experiments and results of RANS and LES (first and second-order statistics as well as local and integral distributions of Nusselt numbers and wall-friction coefficients) for  $Re=5600$  demonstrated an excellent mutual agreement, as well as with spectral DNS results from literature. Dynamical LES have been performed for mixed convection situations at  $Re=20 - 2000$ , and the role of the coherent structures in wall heat transfer has been analyzed.

## DISSERTATIONS

-

## SCIENTIFIC PUBLICATIONS

1. Kuhn, S., Kenjeres, S. and Rudolf von Rohr, P. (2010), Large eddy simulations of wall heat transfer and coherent structures in mixed convection over a wavy wall. International journal of Thermal Sciences, 49 (7), pp. 1209-1226.

Coherent structures in an instantaneous velocity field for a forced convection case over 2D (-left) and 3D (-right) wavy wall extracted by  $\lambda_2$  criteria colored by the vertical velocity component – results from a dynamic LES, Carsten, Kenjeres and von Rohr (2009).

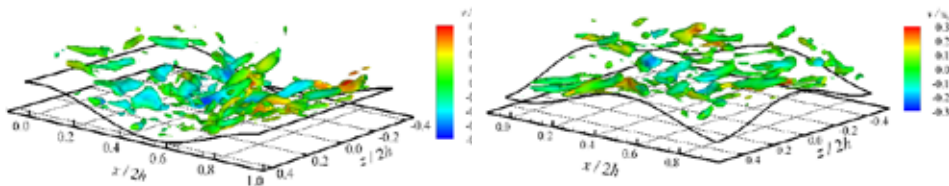

**PROJECT AIM**

This project was partially funded by the EC MAGDYN project (2001-2005) dealing with experimental and numerical studies of magnetic dynamo effects. The final goal of our contribution is to have fully coupled simulations of fluid flow and magnetic fields under realistic conditions, which should capture self-excitation of the magnetic field. This fundamental study of the fluid flow, turbulence and electromagnetic fields interactions can provide new insights into mechanism of the magnetic dynamo that is believed to be behind the origins of planetary magnetic fields (including Earth's magnetic field).

**PROGRESS**

The development of a fully coupled Navier-Stokes/Maxwell solver in complex 3D geometries is completed, and full-scale simulations of the Riga dynamo experimental setup have been performed. Because of the high Re number ( $3.5 \times 10^6$ ), the T-RANS approach is used. Both direct (through momentum equations) and indirect (through additional 'magnetic' terms in the turbulence transport equations) fluid flow/turbulence/electro-magnetic interactions are taken into account. Significant improvements in predictions of the magnetic field growth rate are obtained compared to the more common uncoupled solutions with kinematic solver. The fully coupled simulations captured for the very first time the saturation regime in turbulent flow, in excellent agreement with available experimentally recorded growth rates and frequencies.

**DISSERTATIONS**

-

**SCIENTIFIC PUBLICATIONS**

-

**PROJECT LEADERS**

S Kenjeres

**RESEARCH THEME**

Complex dynamics of fluids

**PARTICIPANTS**

S Kenjeres, K Hanjalic, S Renaudier, F Stefani, A Gaialitis, G Gerbeth

**COOPERATIONS**

TU Dresden; Institute of Physics, Riga; FZR Rossendorf, Dresden; University of Grenoble; University of Maryland, College Park

**FUNDED**

EC, KNAW, TU Delft	
University	25%
FOM	-
STW	25%
NWO Other	-
Industry	-
TNO	-
GTI	-
EU	50%
Scholarships	-

**START OF THE PROJECT**

2002

**INFORMATION**

S Kenjeres  
015 278 3649  
S.Kenjeres@tudelft.nl  
www.msp.tudelft.nl

Numerically predicted contours of the radial (above) and tangential (below) self-induced magnetic field components in the central horizontal plane of the Riga-dynamo setup ( $y = 0$  m) in the kinematic (left column) and saturation (right column) regime, Kenjeres (2009).

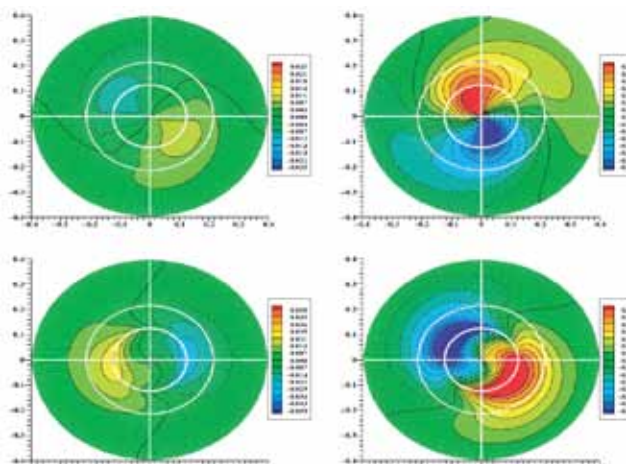

**PROJECT LEADERS**

S Kenjeres, CR Kleijn

**RESEARCH THEME**

Complex dynamics of fluids

**PARTICIPANTS**

S Kenjeres, CR Kleijn

**COOPERATIONS**

-

**FUNDED**

KNAW, TU Delft

University 50%

FOM -

STW 50%

NWO Other -

Industry -

TNO -

GTI -

EU -

Scholarships -

**START OF THE PROJECT**

2001

**INFORMATION**

S Kenjeres

015 278 3649

S.Kenjeres@tudelft.nl

www.msp.tudelft.nl

**PROJECT AIM**

Numerical cal simulations and modeling of thermal and magnetic convection at very high Rayleigh and Hartmann numbers has long been a serious challenge because of the profound effects that buoyancy and Lorentz forces have on the reorganization of the vortical structures, and because of the extreme thinning of the wall boundary layers which requires high numerical resolution. The aim of this study is to develop physically well-based and numerically efficient approaches to tackle problems of highly turbulent thermal and magnetic convection in complex geometries.

**PROGRESS**

Targeting accurate predictions of heat transfer at very high Ra numbers, the performance of T-RANS with a low-Re 3-equation sub-scale model and hybrid seamless RANS/LES have been compared to well-resolved LES in the  $107 < Ra < 109$  range. Whilst the application of conventional coarse grid LES resulted in 50% under-prediction of Nusselt at  $Ra=109$ , the T-RANS results showed excellent agreement for heat transfer with both well-resolved LES ( $107 < Ra < 109$ ) and experiments ( $106 < Ra < 1016$ ). In order to sensitize the T-RANS approach to high-frequency instabilities, different ways of hybrid seamless RANS/LES merging have been investigated. It is demonstrated that the new hybrid approach is capable of capturing a significantly larger portion of the fine-structure spectrum than possible with T-RANS, whilst also returning accurate predictions of heat transfer and turbulence statistics. In addition to T-RANS approach, a magnetically extended SGS model in LES framework has been applied in an intermediate range of Ra numbers (up to  $Ra=1010$ ). In addition to thermal buoyancy driven flows, we also performed DNS studies of flow around magnetic obstacles in transitional flow regimes.

**DISSERTATIONS**

**SCIENTIFIC PUBLICATIONS**

1. Kenjeres, S., ten Cate, S., Voesenek, C.J. (2010). Vortical structures behind magnetic obstacles in transitional flow regimes. In C Dopazo (Ed.), Proceedings of the 8th International Ercoftac Symposium on Engineering Turbulence Modelling and Measurements, Marseille, France, pp.449-454.

Magnetically generated vortex shedding: flow of electrically conductive working fluid subjected to locally imposed magnetic field (magnetic obstacle) in transitional flow regimes ( $Re=900$ ,  $N=10$ , where  $Re$ -is Reynolds number based on half-channel height,  $N$ -magnetic interactive number), Kenjeres, ten Cate and Voesenek (2010).

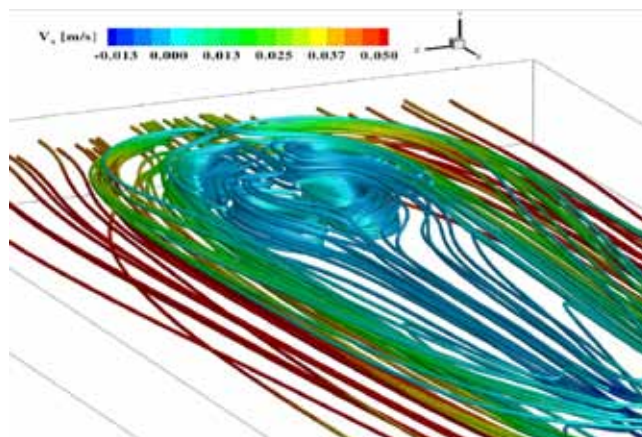

### PROJECT AIM

One of the main problems of chemotherapy is often not the lack of efficient drugs, but the inability to precisely deliver and concentrate these drugs in affected areas. Failure to provide localized targeting results in an increase of toxic effects on neighboring organs and tissues. One promising method to accomplish precise targeting is magnetic drug delivery. Here, a drug is bound to a magnetic compound injected into the blood stream. The targeted areas are subjected to an external magnetic field that is able to affect the blood stream by reducing its flow rate. In these regions the drug is slowly released from the magnetic carriers. Consequently, relatively small amounts of a drug magnetically targeted to the localized disease site can replace large amounts of the freely circulating drug. At the same time, drug concentrations at the targeted site will be significantly higher compared to the ones delivered by standard (systemic) delivery methods. We believe that mathematical modeling and numerical simulations can significantly contribute to further advancements of this technique.

### PROGRESS

We have developed a comprehensive mathematical model for simulations of blood-flow under the presence of strong non-uniform magnetic fields. The model consists of a set of Navier-Stokes equations accounting for the Lorentz and magnetization forces, and a simplified set of Maxwell's equations (Biot-Savart/Ampere's law) for treating the imposed magnetic fields. The relevant hydrodynamic and electro-magnetic properties of human blood were taken from the literature. The model is then validated for different test cases ranging from a simple cylindrical geometry to real-life right-coronary arteries in humans. The time-dependency of the wall-shear-stress for different stenosis growth rates and the effects of the imposed strong non-uniform magnetic fields on the blood flow pattern are presented and analyzed. It is concluded that an imposed non-uniform magnetic field can create significant changes in the secondary flow patterns, thus making it possible to use this technique for optimisations of targeted drug delivery.

### DISSERTATIONS

-

### SCIENTIFIC PUBLICATIONS

1. Rusli, N.B., Kenjeres, S., Yassin, A.Y.M., Hong, A.K.B. and Amin, N. (2010). Three-dimensional numerical simulations of blood flow behaviour in stenotic and aneurysmal arteries. In O Matveichuk & PJ Rosen Esquivel (Eds.), Proceedings of the 1st Regional Conference on Applied and Engineering Mathematics, pp. 197-202, Malaysia.

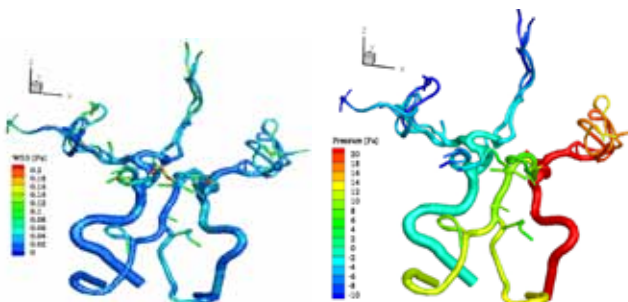

### PROJECT LEADERS

S Kenjeres

### RESEARCH THEME

Complex dynamics of fluids

### PARTICIPANTS

S Kenjeres

### COOPERATIONS

ERASMUS Medical Center  
Rotterdam, Leiden University  
Medical Center (LUMC)

### FUNDED

TUD	
University	100%
FOM	-
STW	-
NWO Other	-
Industry	-
TNO	-
GTI	-
EU	-
Scholarships	-

### START OF THE PROJECT

2006

### INFORMATION

S Kenjeres

015 278 3649

S.Kenjeres@tudelft.nl

www.msp.tudelft.nl

Numerical simulations of pulsating blood flow in brain vascular system: The wall-shear-stress (WSS)(-left) and pressure (-right) distribution in a real patient brain vascular geometry, Kenjeres et al. (2010).

## LIQUID ACCUMULATION IN NEARLY HORIZONTAL PIPELINES WITH MULTIPHASE FLOW AT LOW GAS PRODUCTION RATES

### PROJECT LEADERS

RAWM Henkes, RF Mudde,  
L Portela

### RESEARCH THEME

Complex dynamics of fluids

### PARTICIPANTS

M Birvalski

### COOPERATIONS

Shell

### FUNDED

Shell

University 25%

FOM -

STW -

NWO Other -

Industry 75%

TNO -

GTI -

EU -

Scholarships -

### START OF THE PROJECT

2010

### INFORMATION

RAWM Henkes

015 278 1323

R.A.W.M.Henkes@tudelft.nl

www.msp.tudelft.nl

### PROJECT AIM

The project aims at improving the basic understanding of a key aspect of multiphase flow in pipelines as used in the gas and oil industry, which is the liquid accumulation in systems under turndown operational conditions. The experimental lab configuration will consist of a V-shaped piece of pipeline, representing the low spot. The turbulence levels will be measured using Particle-image Velocimetry. The experimental data will be used to improve the one-dimensional models used in the gas and oil industry, as well as in the next generation type of models, based on three-dimensional Reynolds Averaged Navier Stokes (RANS) equations.

### PROGRESS

The project started in mid 2010. A screening experiment was carried out with air and water in a pipe with 5 cm diameter. The flowloop has a long V-shaped section of 18 meter total length (8.2 meter downward and 9.8 meters upward), and can be adjusted to various inclination angles. In the tests the section has been (symmetrically) set to inclinations of 1, 1.7 and 2.1 deg. The section is pre-filled with an amount of water. The gas flow along the water pool was successively increased. Flow instabilities at the water-air interface are observed. There is a critical gas velocity above which the liquid is suddenly removed from the low spot. The pressure drop and the length of the liquid film were measured. These were used to derive the interfacial stress. The results were compared with various correlations for the interfacial stress. The experiments were repeated with increased liquid viscosity using a water-glycerin mixture. The applicability of the Fluent CFD simulation tool for multiphase pipeline flow was tested. As test cases we took the Benjamin bubble for horizontal pipelines and the Taylor bubble for vertical pipelines. These test cases form a simplification of the more complex slug flow in pipelines. The bubbles were simulated for a range of Reynolds and Eötvös numbers. There is good agreement between the simulation results and the experiments found in the literature.

### DISSERTATIONS

-

### SCIENTIFIC PUBLICATIONS

-

# PERFORMANCE OF FOAMERS FOR DELIQUIFICATION OF GAS WELLS

## PROJECT AIM

This project is a combined experimental/modeling study on the performance of foamers for deliquification of gas wells as used in the gas and oil industry. The reduction of the reservoir pressure for maturing fields will cause that gas wells will start to accumulate liquid (water, condensate). The use of proper foamer chemicals will mix the liquid and gas into a foam, which decreases the hydrostatic head in the well and re-establishes the flow. The study includes flow experiments using a 12 m, 5 cm diameter facility.

## PROGRESS

The project started in December 2010. A literature study was carried out on the chemical-physical aspects of foams and on its engineering applications. Further, small-scale lab tests were carried out for various commercial foamers using a foam column of 400 ml. At the bottom gaseous nitrogen can be sparged through these needles into the foam column. In the tests 40 grams of liquid is placed in the column. This liquid consists of surfactant dissolved in demineralised water. The sparged nitrogen foams the liquid. At the top of the column, the foam is evacuated from the column and collected in a glass container. This procedure continues for 10 minutes. After this time, the weight of the foam in the container is measured. This weight is indicative of the foaming ability of the surfactant.

## DISSERTATIONS

-

## SCIENTIFIC PUBLICATIONS

-

## PROJECT LEADERS

RAWM Henkes, RF Mudde,  
L Portela

## RESEARCH THEME

Complex structures of fluids

## PARTICIPANTS

D van Nimwegen, RAWM Henkes,  
RF Mudde, L Portela

## COOPERATIONS

NAM/Shell

## FUNDED

NAM	
University	25%
FOM	-
STW	-
NWO Other	-
Industry	75%
TNO	-
GTI	-
EU	-
Scholarships	-

## START OF THE PROJECT

2010

## INFORMATION

RAWM Henkes  
015 278 1323  
R.A.W.M.Henkes@tudelft.nl  
www.msp.tudelft.nl



Foam from an experiment with 2000 ppm V-502 foamer and 50% heptane. The left picture is taken at the beginning and the right a picture is taken at the end of the experiment.



**PROJECT LEADERS**

RVA Oliemans, RF Mudde,  
RAWM Henkes

**RESEARCH THEME**

Complex structures of fluids

**PARTICIPANTS**

U Kadri, RVA Oliemans, RF Mudde,  
RAWM Henkes

**COOPERATIONS**

Shell, TNO, DSM

**FUNDED**

STW  
University -  
FOM -  
STW 100%  
NWO Other -  
Industry -  
TNO -  
GTI -  
EU -  
Scholarships -

**START OF THE PROJECT**

2003

**INFORMATION**

RAWM Henkes  
015 278 1323  
R.A.W.M.Henkes@tudelft.nl  
www.msp.tudelft.nl

**PROJECT AIM**

The aim of the project is to study the properties and behavior of long liquid slugs, which can occur in horizontal tubes, when operating in the stratified flow regime at relatively high liquid levels. The project includes measurements in a 2" tube with a total length of 137 m using dedicated measurement equipment to detect the growth and structure of the long liquid slugs. Furthermore, the dynamic modeling of these two-phase flow phenomena will be undertaken.

**PROGRESS**

A proof-of-concept postdoctoral research has been carried out in the first quarter of 2010. The research aimed at providing a method for reducing the negative effects of the long slugs in horizontal pipes. The method is based on increasing the slug frequency of the downstream long slug (and thus on reducing the slug length) through disturbing the flow at the inlet. For the validation of the method, experiments were carried out in a 137 m long air-water horizontal pipe flow with an internal diameter of 0.052 m. The results show that increasing the slug frequency by about 40% results in a decrease of the slug length by 25 to 33%. A paper on the results has been accepted for publication in the Int. J. of Multiphase Flow.

**DISSERTATIONS**

-

**SCIENTIFIC PUBLICATIONS**

1. U. Kadri, R.A.W.M. Henkes, R.F. Mudde, R.V.A. Oliemans, A method for reducing the negative effects of long slugs, Proc. 7th North American Conf. on Multiphase Technology, pp. 53-63, 2010.
2. U. Kadri, R.F. Mudde, R.V.A. Oliemans, Influence of the operation pressure on slug length in near horizontal gas-liquid pipe flow, Int. J. Multiphase Flow 36, 423-431, 2010.

**PROJECT AIM**

The optimization of the production of an oil field depends on the ability to control the wells. Water and gas coning, i.e. the flow of water from a pool below the oil or gas from the gas cap, can severely limit the production. Especially in thin oil rims, where horizontal ('snake') wells and multi-laterals are applied, coning makes operation and production delicate, as coning can occur at any of the many inflow points. Moreover, counter-intuitive well response and the long time constant involved in the operation of oil wells may easily lead to improper control actions that trigger gas coning. Hence, action by operators to increase the production may lead to unstable behavior and will turn the initial increase finally into a dramatic decrease of oil production and possibly to a loss of reservoir pressure. On the other hand, a proper management of the gas production can, via gas lift, enhance the oil production rate and assure a proper recovery of the oil the entire field. Similarly water coning will not only reduce oil production, but may also lead to almost irreversible water break-through.

**PROGRESS**

The project has started in the second half of 2008. First a literature study is conducted. Next, a 1D fluid flow model is developed that deals with multiphase flows and can accommodate various intake points in the pipe line. The code can simulate transient multiphase flows, with an intermittent character. Experiments are conducted in the severe slugging flow loop at Shell Technology Centre Amsterdam, for a downward pipeline-vertical riser system. Experiments for horizontal and upward pipelines are in progress. Analytical models are developed to predict the severe slugging envelop. Shell's in-house multiphase flow simulator, Compas, is used and modified with recently published slip correlations to more robustly predict the severe slugging phenomena. The commercial multiphase flow simulator OLGA, is used for comparison purpose. Also, to model severe slugging in a real oil well and especially, its interaction with a reservoir, a coupled OLGA-steady state near well model is used. We find that our code can predict severe slugging, with realistic pressure fluctuation and slugging time.

**DISSERTATIONS**

-

**SCIENTIFIC PUBLICATIONS**

1. Transient Drift Flux Modeling of Severe Slugging in Pipeline-Riser Systems, 7th International Conference on Multiphase Flow - ICMF 2010 Proceedings, Tampa, FL, USA.

**PROJECT LEADERS**

RF Mudde

**RESEARCH THEME**

Complex dynamics of fluids

**PARTICIPANTS**

R Malekzadeh, RF Mudde

**COOPERATIONS**

ISAPP: Shell, TNO

**FUNDED**

Shell, TNO	
University	-
FOM	-
STW	-
NWO Other	-
Industry	100%
TNO	-
GTI	-
EU	-
Scholarships	-

**START OF THE PROJECT**

2008

**INFORMATION**

RF Mudde  
 015 278 2834  
 r.f.mudde@tudelft.nl  
 www.msp.tudelft.nl

#### PROJECT LEADERS

DJEM Roekaerts, MJ Tummers

#### RESEARCH THEME

Complex dynamics of fluids

#### PARTICIPANTS

LD Arteaga Mendez, MA Etaati

#### COOPERATIONS

W de Jong (3mE, TU Delft),

WS-Prozesstechnik, Stuttgart

Numeca Int., Belgium, TNO glass group

#### FUNDED

Technology Foundation STW, Tata Steel, Shell, NVV, Numeca Int., TNO University -

FOM -

STW 80%

NWO Other -

Industry 15%

TNO 5%

GTI -

EU -

Scholarships -

#### START OF THE PROJECT

2009

#### INFORMATION

LD Arteaga Mendez

015 278 2418

[l.d.arteamendez@tudelft.nl](mailto:l.d.arteamendez@tudelft.nl)

[www.msp.tudelft.nl](http://www.msp.tudelft.nl)

MA Etaati

015 278 2418

[m.a.etaati@tudelft.nl](mailto:m.a.etaati@tudelft.nl)

[www.msp.tudelft.nl](http://www.msp.tudelft.nl)

#### PROJECT AIM

The objective of the flexFLOX project is to investigate both experimentally and computationally the impact of changes in fuel and oxidizer composition on flameless combustion. To reach the flameless combustion regime the air (and/or fuel) streams are diluted with hot combustion products with a temperature sufficiently high for the combustion process to be stable and occurring in a distributed reaction zone. The objective of the part of the flexFLOX project described here is to study experimentally and validate computational models as well as to develop numerical methods (tabulation chemistry method).

#### PROGRESS

The Delft Jet in Hot Coflow (DJHC) burner was upgraded to fire the fuels of the project. The operational characteristics, limitations and performance were assessed by experiments of flow visualization, and temperature and species measurements. The Delft Single Burner Furnace (DSBF) was calculated and designed. The results were tested using commercial CFD codes (Fine/Hexa and Fluent). Finally a detailed CAD model of the DSBF was generated and the manufacturing can start. The in house software, FLAME, has been improved for the computation of three-stream non-adiabatic tabulation method. FLAME is also capable to process different flamelet models, e.g. standard opposed jet diffusion flamelets generated by Fluent, or newer models as FGM, REDIM.

#### DISSERTATIONS

-

#### SCIENTIFIC PUBLICATIONS

1. L. D. Arteaga Mendez, E. Oldenhof, M.J. Tummers, E.H. van Veen, D.J.E.M. Roekaerts. Fuel flexibility in the Delft Jet in Coflow burner, in book of abstracts Combura Symposium, Maastricht, The Netherlands, October 12-13, 2010, p 34, Published by Technology Foundation STW.
2. L. D. Arteaga Mendez, E. Oldenhof, M.J. Tummers, E.H. van Veen, D.J.E.M. Roekaerts, Experimental study on interplay of turbulent mixing and reaction in flameless combustion, in book of abstracts of the Physics@FOM symposium, Veldhoven, The Netherlands, 18-19 January, 2011, p 218.
3. Luis Arteaga Mendez, M.A. Etaati, D.J.E.M. Roekaerts, M.J. Tummers, G. Sarras and W. de Jong, Flameless combustion conditions and efficiency improvements on single and multi-burner FLOXTM furnaces in relation to changes in fuel and oxidizer composition, in book of abstracts Combura Symposium, Maastricht, The Netherlands, October 12-13, 2010, p 33, Published by Technology Foundation STW.
4. M.A. Etaati, M. Stollinger and D.J.E.M. Roekaerts, Tabulated chemistry for three stream non-adiabatic combustion problems, in book of abstracts Combura Symposium, Maastricht, The Netherlands, October 12-13, 2010, p 45, Published by Technology Foundation STW.
5. M.A. Etaati, M. Stollinger and D.J.E.M. Roekaerts, Tabulated chemistry for three stream non-adiabatic combustion problems, in book of abstracts Netherlands Process Technology Symposium 2010 [NPS-10], Veldhoven, The Netherlands, October 25-27, 2010, p129.

# DYNAMIC BEHAVIOUR OF A MULTI-BURNER EXCESS ENTHALPY COMBUSTION (MEEC) SYSTEM FOR INDUSTRIAL PROCESS FURNACES

## PROJECT AIM

Excess Enthalpy Combustion (EEC, also known as flameless combustion) is a new combustion technology that promises higher efficiencies, higher product qualities and lower emissions. Although EEC has already been used in industry, many problems remain to be solved before this technology can be used in furnaces where a large number of burners are needed to deliver the required thermal input. Especially fundamental knowledge is needed regarding the dynamic behavior of this type of novel regenerative burners. For this purpose flames from a "jet-in-hot-coflow burner (JHC)" are studied.

## PROGRESS

Experiments: an extensive database suitable for model validation was generated. The ignition behaviour and the trends in lift-off height were explained. Modeling: the Eddy Dissipation Concept model for turbulence chemistry interaction was applied in simulations of the Delft-jet-in-hot-coflow burner. Flow fields agree well. Ignition is predicted too early. This has been attributed to the properties of the model in the case of relatively low turbulent Reynolds number.

## DISSERTATIONS

-

## SCIENTIFIC PUBLICATIONS

1. E. Oldenhof, M.J. Tummers, E.H. van Veen, and D.J.E.M. Roekaerts, Ignition kernel formation and lift-off behaviour of jet-in-hot-coflow flames, *Combustion and Flame*, 157 (6) 1167-1178, 2010.
2. A. De, E. Oldenhof, P. Sathiah and D.J.E.M. Roekaerts, Numerical investigation of gas jet-in-hot-coflow flames, in proceedings of the 10th International Workshop on Measurement and Simulation of Turbulent Non-Premixed Flames (TNF10), Beijing, China, July 29-31, 2010, Published by R. Barlow, Sandia National Laboratories, Livermore, CA, USA, p. 280.
3. E. Oldenhof, M.J. Tummers, E.H. van Veen and D.J.E.M. Roekaerts, Flame stabilisation of the Delft jet-in-hot-coflow burner, in proceedings of the 10th International Workshop on Measurement and Simulation of Turbulent Non-Premixed Flames (TNF10), Beijing, China, July 29-31, 2010, Published by R. Barlow, Sandia National Laboratories, Livermore, CA, USA, p. 318.
4. E. Oldenhof, M.J. Tummers, E.H. van Veen and D.J.E.M. Roekaerts, Velocities, temperature and OH fields of the DJHC burner, abstract of work in progress poster W5P050, 36th Int. Symposium on Combustion, Beijing, China, August 1-6, 2010, published by The Combustion Institute.
5. A. De, E. Oldenhof, P. Sathiah and D.J.E.M. Roekaerts, Numerical investigation of gas jet-in-hot-coflow flames, abstract of work in progress poster W1P071, 36th Int. Symposium on Combustion, Beijing, China, August 1-6, 2010, published by The Combustion Institute.
6. A. De, E. Oldenhof, P. Sathiah and D.J.E.M. Roekaerts, Numerical investigation of gas jet-in-hot-coflow flames, in book of abstracts Combura Symposium, Maastricht, The Netherlands, October 12-13, 2010, p 42, Published by Technology Foundation STW.

## PROJECT LEADERS

DJEM Roekaerts, MJ Tummers

## RESEARCH THEME

Complex dynamics of fluids

## PARTICIPANTS

E Oldenhof, A De, MK Stollinger

## COOPERATIONS

W de Jong, ES Cho, B Danon (3mE)

## FUNDED

Technology Foundation STW, NVV,

Fluent, TNO, WS Prozesstechnik

University -

FOM -

STW 80%

NWO Other -

Industry 20%

TNO -

GTI -

EU -

Scholarships -

## START OF THE PROJECT

2007

## INFORMATION

MJ Tummers

015 278 2477

m.j.tummers@tudelft.nl

www.msp.tudelft.nl

**PROJECT LEADERS**

MJ Tummers, DJEM Roekaerts

**RESEARCH THEME**

Complex dynamics of fluids

**PARTICIPANTS**

HRC Rodrigues, MJ Tummers

**COOPERATIONS**

Th van der Meer (U Twente),

JBW Kok (U Twente)

**FUNDED**

Technology Foundation STW

(CCC program)

University -

FOM -

STW 80%

NWO Other -

Industry 20%

TNO -

GTI -

EU -

Scholarships -

**START OF THE PROJECT**

2010

**INFORMATION**

HRC Rodrigues

015 278 6745

[h.r.correiarodrigues@tudelft.nl](mailto:h.r.correiarodrigues@tudelft.nl)

[www.msp.tudelft.nl](http://www.msp.tudelft.nl)

**PROJECT AIM**

This project concerns the extension of the application of High Temperature Air Combustion (HiTAC) to heavy-oil combustion processes in a boiler and is a joint project of University Twente and Delft University of Technology. To generate the knowledge needed to be able to develop and design such a boiler, experimental and computational investigations will be made of turbulent spray flames under HiTAC conditions. At TU Delft, an experimental study of spray flames of light fuel oil burning in a co-flow of hot air diluted with combustion products will provide detailed knowledge of the relations between atomization process, ignition, entrainment and burnout.

**PROGRESS**

A test rig was designed and manufactured to emulate entrainment conditions in the furnace under HiTAC mode conditions wherein the spray flame is surrounded by a hot environment with low oxygen concentration. One of the priorities for validation experiments is the uniformity of coflow velocity and scalar properties in the radial direction so that simulations can be modeled as two-stream flow consisting of a spray flame issuing into an infinite hot coflow. It was confirmed experimentally that the radial major species concentrations resulting from use of the proposed new burner holder concept were uniform. Commercial Hollow Cone/Solid nozzles were implemented on the test rig and spray combustion under cold and hot coflow was visually inspected. Measurements regarding the velocity field of the coflow and high speed visualization of the spray will be performed in the near future. A Phase Doppler system (PDA) was purchased in order to measure droplet velocity and diameter under reacting conditions. Several problems regarding the electronics were overcome and it is fully operational. A frame is being designed in order to install the PDA system along with the test rig. A traversing system, fuel injection system and gas compressor are already available making the experimental setup nearly complete.

**DISSERTATIONS**

-

**SCIENTIFIC PUBLICATIONS**

-



**PROJECT AIM**

Development of statistical models for turbulent gaseous flames. The fundamental problem to be addressed is the interaction between the turbulence, chemical reaction and radiation. The main line of investigation is the development of Monte Carlo PDF methods, including models for micromixing.

**PROGRESS**

In the context of transported joint velocity-scalar probability density function methods, the correspondence between Generalized Langevin Models (GLM) for Lagrangian particle velocity evolution and Eulerian Reynolds-stress turbulence models has been established in the 1990's by S.B. Pope. He has shown that the GLM representation of a given Reynolds stress model is not unique. He also has shown that a given GLM together with a given mixing model for particle composition evolution implies a differential scalar-flux model. We have studied how extra constraints can be applied on the choice of the GLM coefficients in order to imply a chosen scalar-flux model. This correspondence between GLM-implied and standard scalar-flux models is based on the linear relaxation term and on the mean velocity gradient contributions in the rapid term. The proposed form of the GLM supposes a non-constant value for the diffusion coefficient  $C_0$ , originally identified as a Kolmogorov constant. The value of  $C_0$  is determined in order to yield the Monin model for linear relaxation of the scalar flux, and the constant in the rapid-pressure contribution is related to the choice of a parameter in the GLM. Finally we have shown how GLM-implied scalar-flux models are in general dependent on the choice of the mixing model and how the proposed GLM can reduce this dependency.

**DISSERTATIONS**

-

**SCIENTIFIC PUBLICATIONS**

- Bertrand Naud, Bart Merci and Dirk Roekaerts, Generalised Langevin model in correspondence with a chosen standard scalar-flux second moment closure, Flow, Turbulence and Combustion, 85 (3), 2010, 363.

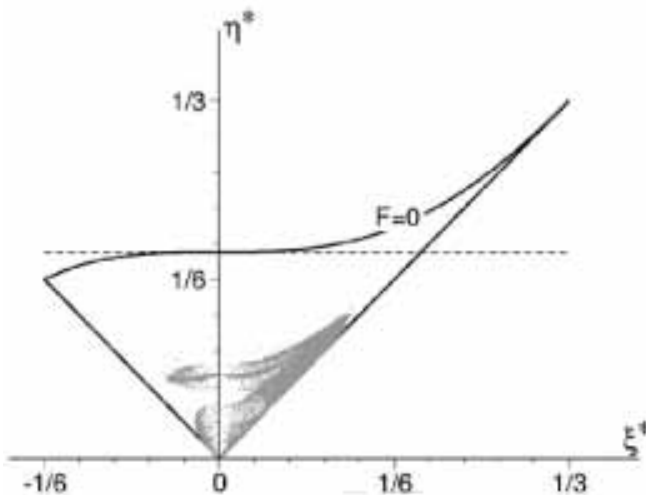

**PROJECTLEADERS**

DJEM Roekaerts

**RESEARCHTHEME**

Mathematical and computational methods for fluid flow analysis

**PARTICIPANTS**

-

**COOPERATIONS**

B Merci (U Gent, Belgium),

B Naud (CIEMAT, Madrid)

**FUNDED**

TU Delft

University 100%

FOM -

STW -

NWO Other -

Industry 50%

TNO -

GTI -

EU -

Scholarships -

**START OF THE PROJECT**

2001

**INFORMATION**

D Roekaerts

015 289 2470

d.j.e.m.roekaerts@tudelft.nl

www.msp.tudelft.nl

**PROJECT LEADERS**

DJEM Roekaerts

**RESEARCH THEME**

Complex dynamics of fluids

**PARTICIPANTS**

MK Stoellinger

**COOPERATIONS**

JBW Kok (U Twente)

**FUNDED**

STW (CCC program)

University -

FOM -

STW 80%

NWO Other -

Industry 20%

TNO -

GTI -

EU -

Scholarships -

**START OF THE PROJECT**

2010

**INFORMATION**

MK Stoellinger

015 278 2418

m.k.stollinger@tudelft.nl

www.msp.tudelft.nl

**PROJECT AIM**

Combustion of natural gas in the range of atmospheric pressure to high pressure (up to ~6-8 bar) at globally rich conditions will be studied computationally and experimentally with the objective to identify trends in production of soot and fixed nitrogen species (HCN, NH<sub>3</sub>) with burner design and operating conditions and to find the optimal operating conditions resulting in the lowest production of these unwanted by-products. The project is executed jointly by University Twente and TU Delft with TU Delft contributing to the modeling part.

**PROGRESS**

A literature study of turbulent combustion models for fuel rich combustion and soot formation was made. State-of-the-art models combine gas phase combustion mechanisms and soot formation mechanisms and turbulence-chemistry interaction models. For the formation and destruction of soot, both semi-empirical two equation models and the methods of moments are commonly. A work plan was developed to implement the models in combination with advanced Monte Carlo simulation methods for turbulent reacting flow.

**DISSERTATIONS**

-

**SCIENTIFIC PUBLICATIONS**

-

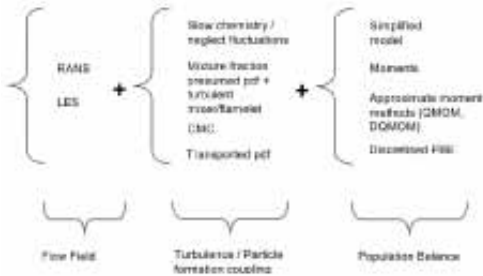

**PROJECT AIM**

The objective of the investigation is to understand the formation of flammable mixtures after an accidental release of a “heavy gas” in a road tunnel with traffic. To reach the objective a combined experimental/numerical investigation will be carried out in which the dispersion of a heavy fluid in a ventilated channel with obstacles is studied. On the basis of the concentration measurements for a system with model fluids it is possible to describe the generation of flammable mixtures in real systems for a series of relevant conditions of the ventilation fluid velocity, injected fluid velocity and density, distance between the obstacles, size and arrangement of the obstacles on the channel floor, etc.

**PROGRESS**

A water channel (dimensions 6.0x0.32x0.16m<sup>3</sup>) equipped with an array of rectangular blocks has been built. Saline water (doped with fluorescene) was injected through a nozzle in the bottom of the channel. Planar Laser Induced Fluorescence was used to determine the concentration fields of injected material for several injection speeds and saline concentrations. The velocity field in the channel was measured at various planes with Particle Image Velocimetry. The instantaneous images were used to determine the mean velocities and the Reynolds stresses. The data on velocity and concentration will be used for validation of CFD codes.

**DISSERTATIONS**

-

**SCIENTIFIC PUBLICATIONS**

-

**PROJECTLEADERS**

MJ Tummers, DJEM Roekaerts

**RESEARCHTHEME**

Complex dynamics of fluids

**PARTICIPANTS**

J Verdoold, MJ Tummers

**COOPERATIONS**

TNO (A. van der Heijden, I.

Trijssenaar-Buhre, e.a.)

**FUNDED**

Delft Cluster (Rijkswaterstaat, TNO, TUDelft)

University	-
FOM	-
STW	-
NWO Other	-
Industry	-
TNO	100%
GTI	-
EU	-
Scholarships	-

**START OF THE PROJECT**

2007

**INFORMATION**

MJ Tummers

015 278 2477

m.j.tummers@tudelft.nl

www.msp.tudelft.nl



**PROJECT LEADERS**

DJEM Roekaerts

**RESEARCH THEME**

Complex dynamics of fluids

**PARTICIPANTS**

M Xie, DJEM Roekaerts

**COOPERATIONS**

TNO Defence, Security and Safety

**FUNDED**

Centrum Ondergronds Bouwen.

Delft Cluster (Rijkswaterstaat, TNO,

TU Delft)

University -

FOM -

STW -

NWO Other -

Industry 100%

TNO -

GTI -

EU -

Scholarships -

**START OF THE PROJECT**

2006

**INFORMATION**

D Roekaerts

015 289 2470

d.j.e.m.roekaerts@tudelft.nl

www.msp.tudelft.nl

**PROJECT AIM**

For a proper risk analysis of accidents in road tunnels accurate estimates of the chances and effects of these accidents is required. This project aims at contributing to a better understanding of the accident known as BLEVE, or boiling liquid expanding vapour explosion. The thermodynamic and fluid dynamic aspects, in particular of the rapid vapourisation after a sudden decrease of pressure will be investigated by a combination of modeling and experiments. The insights gained will be used in predictive models for maximum overpressure in case of an accident and will contribute to the safe evaluation of existing road tunnels and design of future ones.

**PROGRESS**

BLEVE is a problem of two-fluid two-phase compressible flow with heat/mass transfer in superheated states. The transport equations, the equation of state), the numerical scheme and the source term modeling are of the same order of importance in its simulation. Our physical model consists of

1. Equal-Velocity-Unequal-Temperature Euler multi-phase flow equations;
2. Peng-Robinson-Stryjek-Vera equation of state
3. Kinetic superheat limit theory for estimating bubble nucleation rate
4. Nonequilibrium thermodynamics model for interfacial heat/mass fluxes.

The model is solved by the Particle-path scheme for the Method of Characteristics. In 2010 the relaxation time model used previously for interfacial heat and mass fluxes was replaced by non-equilibrium thermodynamics model in which the interfacial heat/mass fluxes are solved by coupling the energy conservation and the mass conservation following Kjelstrup and Bedeaux. The amount of interface area depends on bubble number density and bubble size. These are obtained from kinetic superheat limit theory as proposed by Delale et al.

**DISSERTATIONS**

-

**SCIENTIFIC PUBLICATIONS**

-

# DYNAMIC BEHAVIOR OF A MULTI-BURNER EXCESS ENTHALPY COMBUSTION (MEEC) SYSTEM FOR INDUSTRIAL PROCESS FURNACES

## PROJECT AIM

Excess Enthalpy Combustion (EEC, also known as flameless combustion) is a new combustion technology that promises higher efficiencies, higher product qualities and lower emissions. Although EEC has already been used in industry, many problems remain to be solved before this technology can be used in furnaces where a large number of burners are needed to deliver the required thermal input. Especially fundamental knowledge is needed regarding the dynamic behavior of this type of novel regenerative burners. The main objective of the project is to generate practical knowledge and design rules for EEC systems in a combined experimental and computational approach.

## PROGRESS

Experimental study on the 300 kWth MEEC furnace has been continued. An extended experimental campaign exploiting three burner pairs is performed, measuring emissions both in the regenerated and stack flue gas, in order to improve the understanding of the emission characteristics in the furnace. Also, a new series of experiments was initiated exploiting two burner pairs which will be applied laser-based temperature measurements (CARS) in the near future. Simultaneously, CFD simulations of the furnace equipped with three burner pairs are in an advanced stage of completion. In these simulations a set of detailed models for flow, combustion and radiation is applied. The objective of the simulations is to gain more insight in and possibly find explanations for the differences in the experimental results between different burner configurations in the furnace.

## DISSERTATIONS

-

## SCIENTIFIC PUBLICATIONS

1. Danon, B, de Jong, W, and Roekaerts, DJEM, Experimental and Numerical Investigation of a FLOX Combustor Firing Low Calorific Value Gases, *Combustion Science and Technology*, 182(9), 2010, pp. 1261-1278
2. E.-S. Cho, B. Danon, W. de Jong and D.J.E.M. Roekaerts, Cycle time variations of a multi-burner flameless oxidation furnace, in: *Proceedings of the 8th Int. Symp. on High Temperature Air Combustion and Gasification (HiTACG)*, Poznan, Poland, July 5-7, 2010, pp 229-234, Published by Poznan University of Technology
3. Bart Danon, A. Swiderski, W. de Jong, W. Yang and D.J.E.M. Roekaerts, Investigation of a HiTAC furnace operating in different firing modes, abstract of work in progress poster W1P046, 36th Int. Symposium on Combustion, Beijing, China, August 1-6, 2010, published by The Combustion Institute
4. E.-S. Cho, B. Danon, W. de Jong and D.J.E.M. Roekaerts, Optimization of flameless multi-burner configuration, abstract of work in progress poster W2P043, 36th Int. Symposium on Combustion, Beijing, China, August 1-6, 2010, published by The Combustion Institute
5. B. Danon, E.-S. Cho, W. de Jong and D.J.E.M. Roekaerts, Analysis of CO formation in a multi-burner flameless combustion furnace, *Combustion Symposium*, Maastricht, The Netherlands, October 12-13, 2010, pp 2-3, Published by Technology Foundation STW
6. Bart Danon, Eun-Seong Cho, Wiebren de Jong and Dirk Roekaerts, Carbon monoxide formation in a furnace with regenerative flameless combustion burners, in: *Proceedings of the Eight Asia Pacific Conference on Combustion (ASPACC)*, pp. 551-557, Hyderabad, India, 10-14th December 2010

## PROJECT LEADERS

BJ Boersma, W de Jong (3mE)  
DJEM Roekaerts (TNW and 3mE)

## RESEARCH THEME

Complex dynamics of fluids

## PARTICIPANTS

E-S Cho, B Danon, J Lu

## COOPERATIONS

-

## FUNDED

STW, Industry	
University	-
FOM	-
STW	90%
NWO Other	-
Industry	10%
TNO	100%
GTI	-
EU	-
Scholarships	-

## START OF THE PROJECT

2005

## INFORMATION

E-S Cho  
015 278 5542  
e.s.cho@tudelft.nl  
www.pe.tudelft.nl

## FLAMELESS COMBUSTION CONDITIONS AND EFFICIENCY IMPROVEMENT OF SINGLE- AND MULTI-BURNER-FLOXTM FURNACES IN RELATION TO CHANGES IN FUEL AND OXIDIZER COMPOSITION (FLEXFLOX)

### PROJECT LEADERS

BJ Boersma (3mE), W de Jong (3mE), DJEM Roekaerts(3mE and TNW)

### RESEARCH THEME

Complex dynamics of fluids

### PARTICIPANTS

G Sarras

### COOPERATIONS

MK Stollinger (TNW)

### FUNDED

Technology Foundation STW, Corus, Shell, NVV, Numeca Int., TNO

University -

FOM -

STW 80%

NWO Other %

Industry 15%

TNO 5%

GTI -

EU -

Scholarships -

### START OF THE PROJECT

2010

### INFORMATION

GSarras

g.sarras@tudelft.nl

www.et.3mE.tudelft.nl

### PROJECT AIM

The objective of the flexFLOX project is to investigate both experimentally and computationally the impact of changes in fuel and oxidizer composition on flameless combustion. To reach the flameless combustion regime the air (and/or fuel) streams are diluted with hot combustion products with a temperature sufficiently high for the combustion process to be stable and occurring in a distributed reaction zone. The objective of the part of the flexFLOX project described here is to develop and validate computational models.

### PROGRESS

In order to simulate accurately the turbulent combustion of the Delft-Jet-in-Hot-Coflow (DJHC) burner statistical methods are used. A 2D axisymmetric grid simulation was performed with the transported probability density function (PDF) method in conjunction with equilibrium chemistry for the DJHC-I\_S flame at  $Re=4500$ . As it was expected, the equilibrium assumption is not valid and more accurately simplified chemistry models are required and need to be tested for their performance.

### DISSERTATIONS

-

### SCIENTIFIC PUBLICATIONS

1. Luis Arteaga Mendez, M.A. Etaati, D.J.E.M. Roekaerts, M.J. Tummers, G.Sarras and W. de Jong, Flameless combustion conditions and efficiency improvements on single and multi-burner FLOXTM furnaces in relation to changes in fuel and oxidizer composition, in book of abstracts Combura Symposium, Maastricht, The Netherlands, October 12-13, 2010, p 33, Published by Technology Foundation STW.





Prof.dr.ir. ThJJ van der Hagen

### MISSION

The reactor physics department contributes to the development of sustainable nuclear energy such that it can play a major role in the global energy production. To this end, we focus on new and innovative nuclear reactors with improved efficiency, a high degree of safety, flexibility, and with a reduced waste production.

### RESEARCH

Research in the department can be divided into three categories:

1. Thermal Hydraulics of Nuclear Reactors
  - ♦ Experimental research on stability of natural circulation Boiling Water Reactors with enhanced safety features.
  - ♦ Numerical analyses of thermal-hydraulic phenomena in new reactors like the SBWR and others. This also includes method and code development.
  - ♦ Thermo-Siphon research.
2. Reactor Physics Analysis of New Reactor Designs
  - ♦ VHTR: Design and analysis of a gas-cooled Very High Temperature Reactor for hydrogen production. Focus on core design and safety/transient analysis.
  - ♦ GCFR: Design and analysis of a Gas-Cooled Fast Reactor with a self-generating core and reduced waste production.
  - ♦ ADS: Dynamics analysis and development of reactivity measuring methods for Accelerator Driven Systems.
  - ♦ MSR: Design and Analysis of a Molten Salt Reactor with a high-conversion and/or breeding fuel cycle. Focus on core design, fuel cycle analysis, and dynamics and safety analyses.
  - ♦ Exotic designs, like the Fluidized Bed Reactor with a fast neutron spectrum, the CANDLE burnup reactor, and reactors for new applications.
3. Methods and Codes for Reactor Physics and Particle Transport
  - ♦ Development and application of electron-photon-neutron particle transport, possibly coupled to other codes like CFD.
  - ♦ Development and application of Monte Carlo transport methods possibly coupled to other codes like deterministic transport codes, and CFD.
  - ♦ Development and application of new reactor physics methods, like - mode calculations, coupled time-dependent neutronics and thermal-hydraulics, etc.
  - ♦ Development of methods to reduce leakage of nuclides from a geological disposal site.

**PROJECT AIM**

To develop a deep understanding of the inter sub-channel cross flow in a vertical rod bundle geometry. The project aim is motivated by the existence of the cross flow in the core of light water nuclear reactors and its effect on the local power production and the heat transfer from the fuel rods to the coolant due to different feedback mechanisms. During the project the existence and origin of the large scale vortices near the channel gap interface and their role towards the cross flow mixing will be investigated.

**PROGRESS**

In this year, the focus has been on the identification of coherent structures in a realistic bundle geometry as one can find in nuclear reactors. Moreover, cross-flow mixing (i.e. radial mixing) and the modeling have been studied. In order to be able to measure the velocities inside the bundle geometry with LDA, a Refractive Index Matching (RIM) technique was used. For this technique, Fluorinated Ethylene Propylene (FEP) was used as tube material. It had been shown that FEP could be effectively used as a solid RIM material with water at ambient conditions. Experiments on the radial mixing of a passive scalar induced by crossflow showed that the mechanisms responsible for the inter-channel mixing strongly depend on the gap hydraulic diameter. If present, the coherent structures were found to impart a significant contribution towards crossflow mixing for all channel Reynolds numbers. The defense of this PhD project will take place on June 23, 2011.

**DISSERTATIONS**

-

**SCIENTIFIC PUBLICATIONS**

-

**PROJECT LEADERS**

M Rohde

**RESEARCH THEME**

Complex structures of fluids

**PARTICIPANTS**

A. Mahmood, M. Rohde, Tim van der Hagen, Rob Mudde, Luis Portela

**COOPERATIONS**

PNR/RID (TU Delft)  
Multi-Scale Physics (TU Delft)  
NFI Limited (Japan)

**FUNDED**

HEC/NUFFIC, TUDelft.  
University 45%  
FOM -  
STW -  
NWO Other -  
Industry 10%  
TNO -  
GTI -  
EU -  
Scholarships 45%

**START OF THE PROJECT**

2006

**INFORMATION**

M Rohde  
015 278 6962  
m.rohde@tudelft.nl

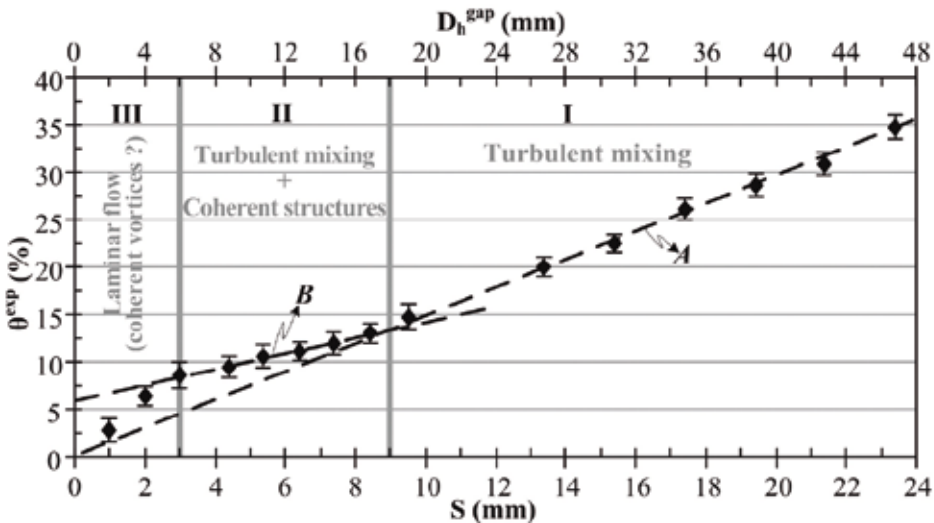

Inter-channel mixing as a function of various gap spacing, for constant Re<sub>ch</sub> = 10,000. For comparison purposes, the gap hydraulic diameter is shown on a secondary x-axis. The dashed line represents a linear fit to the data points.

**PROJECT LEADERS**

M Rohde

**RESEARCH THEME**

Complex structures of fluids

**PARTICIPANTS**

M Rohde, C T'Joen

**COOPERATIONS**

-

**FUNDED**

NWO (Veni Scheme)	
University	25%
FOM	-
STW	-
NWO Other	50%
Industry	25%
TNO	-
GTI	-
EU	-
Scholarships	-

**START OF THE PROJECT**

2007

**INFORMATION**

M Rohde  
015 278 6962  
m.rohde@tudelft.nl  
www.rrr.tudelft.nl/pnr

**PROJECT AIM**

One of GEN-IV reactor concepts is the so-called supercritical water reactor (SCWR), in which supercritical water is used to cool the nuclear core. This would result in a higher thermal efficiency. An important topic that needs to be studied is the reactor stability. In this project the possibility of cooling the SCWR by natural circulation is considered. This enhances the inherent safety of the reactor, since perturbations in the flow are weakened by the density response in the core (negative feedback). A consequence, however, is that the physics become more complicated. Hence, studying (and guaranteeing) stability of such a system will become a great challenge.

**PROGRESS**

An experimental facility 'DeLight' was designed and constructed at the Delft University of Technology. This facility is a scaled version of the European concept of the SCWR, named the HPLWR and can operate in both natural and forced circulation mode. To lower the pressure and temperatures a scaling fluid was used, Freon R-23. To mimic a nuclear reactor, artificial neutronic feedback was used. It was shown that when operating in natural circulation, there are no thermo-hydraulic instabilities. However, the neutronic feedback can induce instabilities. These are then quantified by the 'decay ratio' of the measured signals. By varying the inlet temperature and power of a system, stability maps can be drawn which visualise the system behaviour at different operational conditions. By varying the fuel time constant  $\tau$  it was shown that at higher fuel time constants the system becomes increasingly unstable, as shown in the figure below.

**DISSERTATIONS**

-

**SCIENTIFIC PUBLICATIONS**

1. T'JOEN, C; ROHDE, M; VISSER, DC; LYCKLAMA A NIJEHOLT, JA; ROELOFS, F; VAN DER HAGEN, THJJ; Preliminary natural circulation data of a scaled HPLWR experiment, IEAE Technical meeting on heat transfer, thermal-hydraulics and system design for supercritical pressure water cooled reactors, Pisa, Italy, 5-8 July 2010.
2. ROELOFS, F., ROHDE, M. et al; Cross-cutting European Research for Single Phase Turbulence in Innovative Reactors. NUTHOS-8, Shanghai, China.

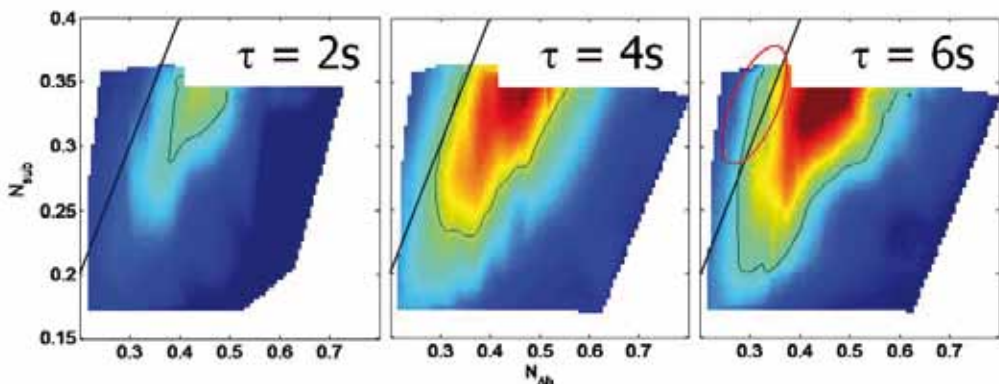







Prof.dr.ir. M-O Coppens

Our research objective is to introduce conceptually new approaches to address the development of sustainable chemical technologies that are in harmony with nature, and are, as such, both efficient and effective. Problems studied are typically fundamental in nature, yet society-driven, with practical applications in mind.

Inspiration is drawn from universal, hierarchical patterns, networks and symmetries present in nature, such as self-similarity, which link the micro- and the macro-scale in a very efficient, scalable way. The “architecture” and thermodynamics of nature and the life sciences are the basis for new, rational designs of porous materials and processes. Applications include catalysis, separations, chemical reactor engineering, and controlled delivery. Natural structures are taken as a lead, and not as a dogma for optimality – hence nature-inspired, and not always bio-mimetic.

At the heart of these rational, nature-inspired designs lies a better understanding and control of physico-chemical phenomena spanning multiple length and time scales. For this reason, much of our attention goes to the development of mesoscopic theories and hierarchical, statistical mechanical modelling approaches.

In the context of the JMBC, current research topics include (much in collaboration between M.-O. Coppens and J.R. van Ommen):

- ◆ novel ways to “structure” fluidized beds and other multiphase reactors
- ◆ characterization of multiphase flow using novel statistical techniques
- ◆ self-assembly and pattern formation

Analytical and computational work are combined with experiments.

Other research focuses on:

- ◆ rational design and synthesis of hierarchical porous materials
- ◆ effects of heterogeneity on transport in porous materials, for catalysis, separations and controlled release (rough mesoporous materials, zeolites, protein crystals and ion channels), in particular using statistical mechanical simulations and analytical calculations.
- ◆ non-equilibrium thermodynamics

## CONTINUOUS-FLOW SYNTHESIS OF CORE-SHELL NANOPARTICLES FOR CATALYTIC APPLICATIONS

### PROJECT AIM

The aim of the project is to synthesize monodisperse core-shell nanoparticles with pre-defined properties, understand factors influencing the morphology, as well as getting insight into the coating process of nanoparticles in liquid and gas phase.

### PROGRESS

A review has been made of the literature concerning mechanism of nanoparticles formation, core-shell nanoparticles synthesis, multi-phase flow in microfluidic devices. The PhD student has gained experimental experience with cleanroom methods of microreactor fabrication with focus on PDMS/glass microfluidic devices. We studied Taylor flow in microfluidic devices and mixing efficiency inside droplets. We have worked on the seed-mediated growth method, i.e. pre-synthesized nanoparticles are added to a growth solution in order to obtain anisotropic particles. We studied controlled growth of gold nanoparticles in a batch mode and in microreactors in order to reveal influence of mixing on dispersity of nanoparticles. The project is carried out in close cooperation with the Catalysis Engineering group of our department: they will study the catalytic application of the nanoparticles, especially in electrocatalytic CO<sub>2</sub> reduction.

### DISSERTATIONS

-

### SCIENTIFIC PUBLICATIONS

-

### PROJECT LEADERS

JR van Ommen, MT Kreutzer

### RESEARCH THEME

Complex structures of fluids

### PARTICIPANTS

B Kampa (PhD student)

### COOPERATIONS

Catalysis Engineering group of ChemE, TU Delft

### FUNDED

NRSC-Catalysis	
University	-
FOM	-
STW	-
NWO Other	-
Industry	100%
TNO	-
GTI	-
EIU	-
Scholarships	-

### START OF THE PROJECT

2009

### INFORMATION

BM Kampa,  
015 278 8188  
b.m.kampa@tudelft.nl  
www.cheme.tudelft.nl/ppe

**PROJECT LEADERS**

JR van Ommen, M-O Coppens

**RESEARCH THEME**

Complex structures of fluids

**PARTICIPANTS**

-

**COOPERATIONS**

N Ellis, University of British Columbia, Canada

**FUNDED**

Rhodia  
 University -  
 FOM -  
 STW -  
 NWO Other -  
 Industry 100%  
 TNO -  
 GTI -  
 EU -  
 Scholarships -

**START OF THE PROJECT**

2004

**INFORMATION**

R van Ommen  
 015 278 2133  
 j.r.vanommen@tudelft.nl

Marc-Olivier Coppens  
 coppens@rpi.edu

**PROJECT AIM**

This projects aims at imposing structure on gas-solids fluidized beds, with the following advantages:

- A reduction in bubble size, which leads to better mass transfer;
- In addition, a reduced bubble size leads to less erosion, attrition, and elutriation;
- A structured system is easier to model and to scale-up;
- More independent variables facilitate model validation;
- A structured system offers more possibilities to adjust the process during operation.

**PROGRESS**

Structuring can be done either by modifying the gas supply or by interfering in the particle phase. In both cases, either the dynamics can be changed or the configuration can be altered. This yields a total of four different possibilities:

1. Oscillating the gas supply;
2. Varying the interparticle forces, which is conveniently done using an AC electric field;
3. Distributing the gas supply over the height of the bed;
4. Varying the particle size distribution and other distributed particle properties.

All these four possibilities have been investigated in the past years. Each possibility has its own typical applications for which it is the best choice. Currently, we are focussing on method 1 with the aim of improving heat transfer and drying.

**DISSERTATIONS**

-

**SCIENTIFIC PUBLICATIONS**

1. Vervloet, D., Nijenhuis, J., van Ommen, J.R., 'Monitoring a lab-scale fluidized bed dryer: A comparison between pressure transducers', passive acoustic emissions and vibration measurements, Powder Technology, 197, pp. 36-48, 2010.
2. van Ommen, J.R., Ellis, N., Influence of fines on fluidized bed behaviour, Proceedings of the World Congress on Particle Technology (WCPT6), Nuremberg, 2010.
3. Hadi, B., van Ommen, J.R., Coppens, M.-O., Improved heat transfer in structured fluidized beds by two innovative techniques: gas pulsation and fractal injection, Proceedings of the World Congress on Particle Technology (WCPT6), Nuremberg, 2010.

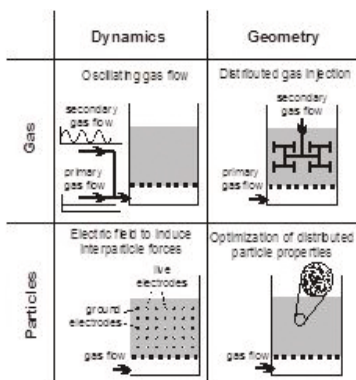

**PROJECT AIM**

Our goal is to evaluate the local intensity of light in a multiphase photoreactor in order to calculate the local rate of photon absorption by the photocatalyst. As light propagates in a heterogeneous medium, it is attenuated through either absorption or scattering by particles and/or bubbles. Since, a photoreaction will not occur, unless the light is present in the system, the study of light attenuation is a necessity for the kinetic studies, and also for the design of a photoreactor. The knowledge over the local intensity of light, will help us design more photonic-efficient reactors.

**PROGRESS**

We have investigated the propagation of light in a liquid-solid slurry containing TiO<sub>2</sub> particles. Using a Monte Carlo simulation and also flux models, we have studied the scattering and absorption of light by TiO<sub>2</sub> particles and calculated the local volumetric rate of photon absorption in a photoreactor. The experimental work to validate these models is to be performed in the near future. Nonetheless, the outcome of the Monte Carlo model was compared with the transmission data presented in the literature. Such comparison posed doubts on the accuracy of the reported optical properties of TiO<sub>2</sub> particles in the literature. Furthermore, we developed a model for the study of scattering by bubbles in liquid. The model is based on Snell and Fresnel's laws of reflection and refraction, the experimental validation of which will be followed shortly.

**DISSERTATIONS**

-

**SCIENTIFIC PUBLICATIONS**

-

**PROJECT LEADERS**

JR van Ommen, PW Appel, MT Kreuzer

**RESEARCH THEME**

Complex structures of fluids

**PARTICIPANTS**

Mahsa Motegh

**COOPERATIONS**

-

**FUNDED**

DUT	
University	100%
FOM	-
STW	-
NWO Other	-
Industry	-
TNO	-
GTI	-
EU	-
Scholarships	-

**START OF THE PROJECT**

2009

**INFORMATION**

Mahsa Motegh  
015 278 8949  
m.motegh@tudelft.nl

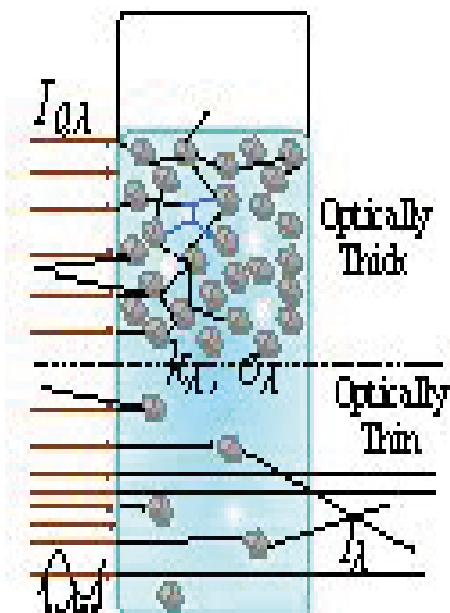

Absorption and scattering of Light in a multiphase photoreactor

**PROJECT LEADERS**

PJ Hamersma, RF mudde,  
JR van Ommen

**RESEARCH THEME**

Complex structures of fluids

**PARTICIPANTS**

Nasim Hooshyar (PhD student)

**COOPERATIONS**

-

**FUNDED**

TUD

University 100%

FOM

-

STW

-

NWO Other

-

Industry

-

TNO

-

GTI

-

EU

-

Scholarships

-

**START OF THE PROJECT**

2008

**INFORMATION**

Nasim Hooshyar

015 278 4753

N.Hooshyar@tudelft.nl

**PROJECT AIM**

We aim at structuring the flow and reducing backmixing in slurry bubble columns. To impose a structure on the hydrodynamics in a slurry bubble column we have focused on structuring by manipulating the gas phase. We believe that an increase in the axial dispersion increases the conversion in these type of three-phase catalytic reactors.

**PROGRESS**

We have investigated uniform gas injection using a needle sparger as a structuring methodology to reduce backmixing in slurry bubble columns. Using optical probes, we determined the gas fraction and the bubble behavior in 2D and 3D slurry bubble columns with a uniform gas injection. Experimental results for air-water-glass beads indicate that a strong reduction in the vortical structures has been achieved and the homogeneous flow regime can be extended beyond 30% gas fraction. Increasing the solids concentration decreases the gas fraction and widens the bubble velocity distribution. Moreover, using optical probes, we measured the gas fraction and bubble dynamics in a 3D column equipped with a perforated plate in order to compare the results with the structured column. Furthermore, we have done a fundamental study to investigate the effect of an increase in solids volume fraction on a single bubble dynamics. Our results show that an increase in solids volume fraction did not change the velocity and the volume of a single bubble.

**DISSERTATIONS**

-

**SCIENTIFIC PUBLICATIONS**

1. Hooshyar, N.; Hamersma, P. J.; Mudde, R. F.; van Ommen, J. R., Intensified operation of slurry bubble columns using structured gas injection. *Canadian Journal of Chemical Engineering* 2010, 88, (4), 533-542.
2. Hooshyar, N.; Hamersma, P. J.; Mudde, R. F.; Van Ommen, J. R., Gas fraction and bubble dynamics in structured slurry bubble columns. *Industrial and Engineering Chemistry Research* 49, (21), 10689-10697.

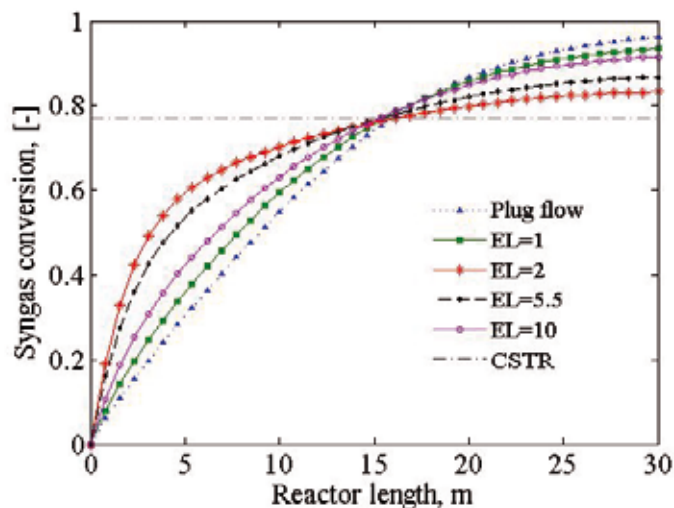

**PROJECT AIM**

The objective of our study is to identify and develop novel solvents for CO<sub>2</sub> pre-combustion capture. The absorption behavior of candidate solvents is studied in special adapted equipment. A micro-channel reactor is developed for a new characterization method for the CO<sub>2</sub> absorption of different solvents. This new characterization method allows the rapid determination of intrinsic properties of the novel solvents, such as phase equilibrium and intrinsic kinetics.

**PROGRESS**

We focused on the development of experiments on the micro-scale. A model was developed to describe the gas-liquid absorption along the micro-channel. Solvents with known characteristics such as DEPEG, NMP, 1-octanol and water were screened using this method for validation purposes. In this way information about the equilibrium solubility and mass transfer characteristics of the tested fluids can be obtained.

**DISSERTATIONS**

-

**SCIENTIFIC PUBLICATIONS**

-

**PROJECTLEADERS**

PJ Hamersma, MT Kreutzer, A Bardow, A Stankiewicz

**RESEARCHTHEME**

Mathematical and computational methods for fluid flow analysis

**PARTICIPANTS**

Stephanie Lefortier (PhD)

**COOPERATIONS**

-

**FUNDED**

Decarbit (EU project)

University -

FOM -

STW -

NWO Other 100%

Industry -

TNO -

GTI -

EU -

Scholarships -

**START OF THE PROJECT**

2008

**INFORMATION**

S Lefortier

015 278 8188

s.g.r.lefortier@tudelft.nl

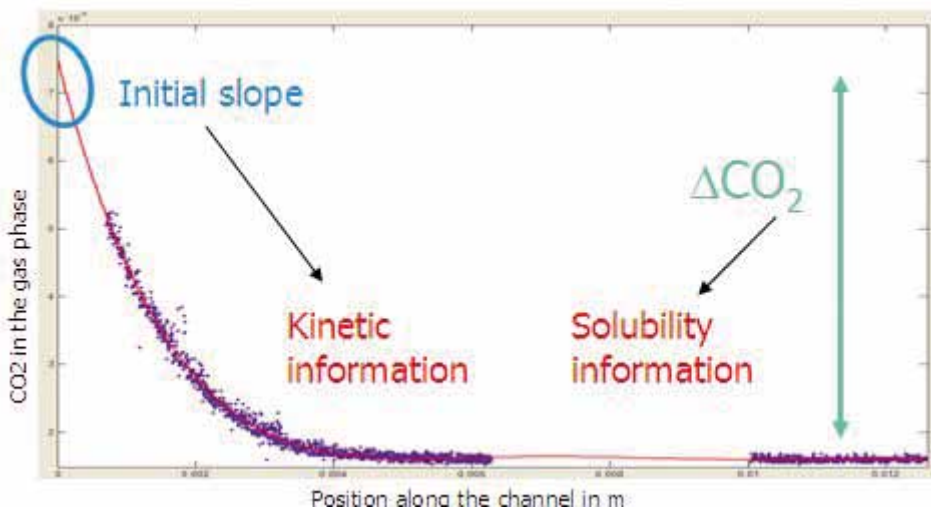



Prof.dr.ir. H Bijl



Prof.dr. F Scarano



Prof.dr.ir. PG Bakker

The research in the Aerodynamics Group involves fundamentals of Fluid Dynamics and its applications to aerodynamic problems of relevance in Aerospace Engineering systems.

The activities cover boundary layer research in low speed and high-speed flows, including re-entry aero-thermodynamics, complex unsteady flows, fluid-structure interaction problems and aeroacoustics.

The group works in close connection with the Wind Energy section for the investigation of rotor blade aerodynamics. Specific flow control strategies by passive (e.g. vortex generators) and active means (suction, plasma actuators) are explored for their application in flow transition and separation delay.

The experimental research is supported by the Aerodynamics Laboratories, which cover flow simulation range from incompressible to hypersonic regime. Emphasis is given to the development and application of image based advanced flow diagnostic techniques like Tomographic PIV, Background Oriented Schlieren, InfraRed Thermography.

The study of Fluid-Structure interactions and of unsteady flow simulation drive the development of efficient simulation tools for 3D-unsteady viscous flows (e.g. adaptive meshing, mimetic methods, multiscale computation of turbulence). Applications range from flapping wings and micro aerial vehicle aerodynamics to aircraft flutter and unsteady loads on wind turbines. The research on CFD also covers quantification of uncertainties in aerodynamics problems simulation.

**PROJECT AIM**

TUD is focusing on high fidelity computations and increasing their computational speed by using reduced order models to speed up the convergence of the solution, especially for fluid structure interaction computations. For this algorithms have to be developed to take into account the information from a reduced order model in the full order model computation (and possibly vice versa: correct (or increase the accuracy of) the reduced order model using results from the full order model).

**PROGRESS**

- 1) A literature survey is performed to numerical methods that incorporate information of reduced order models in order to speed up the computation.
- 2) A technique from multi-fidelity optimization, called space-mapping, is applied to academic fluid-structure interaction problems. Space mapping allows to accelerate the partitioned fluid-structure algorithm using information of a reduced order model. The results will be presented at the conference "Coupled problems 2011", Kos Island, Greece, 20-22 june 2011.

**DISSERTATIONS**

-

**SCIENTIFIC PUBLICATIONS**

-

**PROJECTLEADERS**

H Bijl, AH van Zuijlen

**RESEARCHTHEME**

Mathematical and computational methods for fluid flow analysis

**PARTICIPANTS**

TP Scholcz

**COOPERATIONS**

University of Bristol, INRIA, CSIR, DLR, IRIAS, University of Liverpool, Politecnico di Milano, NUMECA, Optimad Engineering, Airbus-UK, EADS-MS and IITP

**FUNDED**

EU (FP7)	
University	-
FOM	-
STW	-
NWO Other	-
Industry	-
TNO	-
GTI	-
EU	100%
Scholarships	-

**START OF THE PROJECT**

2010

**INFORMATION**

TP Scholcz  
015 278 8690  
t.p.scholcz@tudelft.nl



**PROJECT LEADERS**

H Bijl, BW van Oudheusden

**RESEARCH THEME**

Complex dynamics of fluids

**PARTICIPANTS**

WB Tay, M Percin

**COOPERATIONS**

Univ. Lund, Univ. Michigan, AFRL

**FUNDED**

STW

University	-
FOM	-
STW	100%
NWO Other	-
Industry	-
TNO	-
GTI	-
EU	-
Scholarships	-

**START OF THE PROJECT**

2010

**INFORMATION**

BW van Oudheusden

015 278 5349

B.W.vanOudheusden@tudelft.nl

http://www.tudelft.nl/

**PROJECT AIM**

The project is a continuation of previous research on flapping-wing propulsion in the flight regime of insects ( $Re \sim 100$  to  $1000$ ). The present interest lies in the particular application of experimental and computational analysis tools to investigate flapping-wing Micro Aerial Vehicles (MAVs). Specific challenges are the wing-wing interaction, the high amount of wing flexibility, and the higher Reynolds number regime ( $10,000 - 100,000$ ) which requires transitional and/or turbulent flow modeling.

**PROGRESS**

In 2010 a new project was initiated, based on STW funding, to further investigate the flapping-wing phenomena observed on the DelFly MAV in previous experimental studies. Computational activities compare the relative performance for deforming mesh strategies (ALE) and IBM (immersed boundary methods). The experimental work has two components: 1) the study of related generic aeroelastic phenomena and 2) a more detailed characterization of the DelFly aerodynamics (wake structure; forward flight regime).

**DISSERTATIONS**

1. FM Bos: Numerical simulations of flapping foil and wing aerodynamics; TU Delft, 24 Feb 2010. ISBN 978-90-9025173-8.

**SCIENTIFIC PUBLICATIONS**

1. M Groen, B Bruggeman, B Remes, R Ruijsink, B van Oudheusden, H Bijl: Improving flight performance of the flapping wing MAV DelFly II, International Micro Air Vehicle Conference and Flight Competition (IMAV 2010), Braunschweig, Germany, 6-9 July 2010, 17 pp.

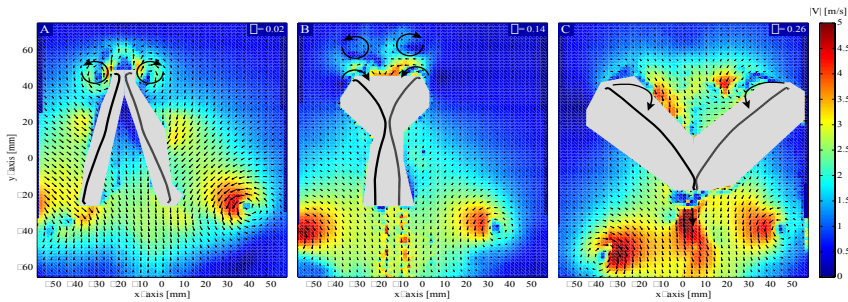

The flow around the wings of the DelFly MAV (PIV measurements)

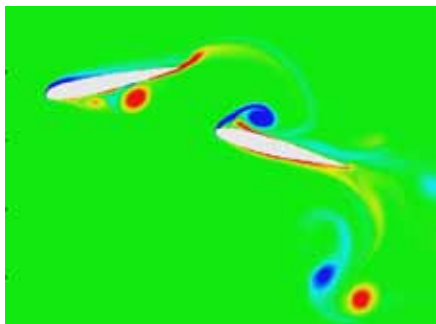

Numerical simulation (2D-IBM) of tandem wing configuration with flapping wing and stationary tail airfoil.

# FLOVIST: FLOW VISUALIZATION INSPIRED AEROACOUSTICS BY TIME RESOLVED TOMOGRAPHIC PARTICLE IMAGE VELOCIMETRY

## PROJECT AIM

Development of advanced experimental techniques for the aeroacoustic analysis of turbulent flows of relevance in aerodynamics. The research is based on the extensive use of advanced flow diagnostics and in particular of time-resolved 3D velocimetry by Tomography. The technique is based on acoustic source detection and sound emission modelling based on acoustic analogies. The applications cover aircraft aerodynamics (trailing-edge noise) propulsion (jet noise) and include the area of wind turbines (rotor blade tip and trailing aerodynamics).

## PROGRESS

Advances in Tomographic PIV. In 2010 the tomographic reconstruction of 3D particle fields based on two exposures (motion tracking enhanced MTE-MART) has been experimentally verified, with significantly improved capabilities in highly seeded flows. Time resolved analysis of transitional jets. Experiments performed by high-resolution time-resolved tomographic PIV were performed on circular, chevron and swirled jets (collaboration with University of Naples). The data show that the Powell acoustic source can be identified and associated to specific flow structures. Time-resolved Tomo-PIV of the flow past a NACA-0012 airfoil. The study is conducted to characterize the statistical properties of turbulence undergoing the airfoil sharp edge. First evidence is obtained of counter-hairpin vortices contributing in the mixing process in the near wake.

## DISSERTATIONS

1. Theunissen R, Adaptive image interrogation for PIV: application to compressible flows and interfaces, TU Delft, Aerospace Engineering, 2010-02-18, Promotor: Scarano F.

## SCIENTIFIC PUBLICATIONS

1. Scarano F, 3D Optical Diagnostics from Aerodynamics to Hydraulics, Journal of Hydraulic Research, 48, 62-65.
2. Ghaemi S, Scarano F, Multi-pass light amplification for tomographic particle image velocimetry applications, Meas. Sci. Technol. 21.
3. Novara M, Batenburg KJ, Scarano F, Motion tracking-enhanced MART for tomographic PIV, Meas. Sci. Technol, 21.
4. Scarano F, Bryon K, Violato D, Time-resolved analysis of circular and chevron jets transition by Tomo-PIV, 15th Int. Symp. Appl. Lase Techn. Fluid mech., Lisbon (PT).
5. Violato D, Moore P, Scarano F, Lagrangian and Eulerian pressure field evaluation of rod-airfoil flow from time-resolved tomographic PIV, Exp. Fluids, 50.
6. Schmid PJ, Violato D, Pust O, Scarano F, Decomposition of time-resolved tomographic PIV, 15th Int. Symp. Appl. Lase Techn. Fluid mech., Lisbon (PT).
7. Novara M, Scarano F, Performances of motion tracking enhanced Tomo-PIV on turbulent shear flows, 15th Int. Symp. Appl. Lase Techn. Fluid mech., Lisbon (PT).
8. Scarano F, Moore P, An advection model to increase the time-resolution of PIV time-series, 15th Int. Symp. Appl. Lase Techn. Fluid mech., Lisbon (PT).

## PROJECT LEADERS

F Scarano

## RESEARCH THEME

Complex dynamics of fluids

## PARTICIPANTS

P Moore, M Novara, D Violato, S Ghaemi, A Ianiro, R Theunissen

## COOPERATIONS

Nationaal Luchtvaart Laboratorium (NLR), University of Naples (UNINA) LaVision GmbH

## FUNDED

European Research Council (ERC)	
University	-
FOM	-
STW	-
NWO Other	-
Industry	-
TNO	-
GTI	-
EU	100%
Scholarships	-

## START OF THE PROJECT

2008

## INFORMATION

F Scarano  
015 278 5902  
f.scarano@tudelft.nl

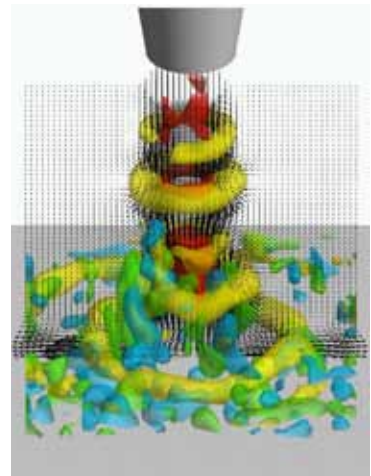

Tomographic PIV measurements of impinging jet, vortex visualization by Q-criterion (yellow).

**PROJECT LEADERS**

FFJ Schrijer, F Scarano, BW van Oudheusden

**RESEARCH THEME**

Complex dynamics of fluids

**PARTICIPANTS**

Z Sun, D Ragni, S Ghaemi

**COOPERATIONS**

ESA, VKI, DLR, NLR, ASTRIUM, TNO

**FUNDED**

-	
University	50%
FOM	-
STW	-
NWO Other	25%
Industry	-
TNO	-
GTI	-
EU	-
Scholarships	25%

**START OF THE PROJECT**

2003

**INFORMATION**

F Schrijer  
015 278 6386  
f.f.j.schrijer@tudelft.nl

**PROJECT AIM**

Development and implementation of non-intrusive measurement techniques for high-speed compressible flows with special focus on particle image velocimetry. The measurements techniques are subsequently used to investigate flow phenomena that are pertinent to launchers, high-speed air transport systems and reentry vehicles. Specific topics that are studied are shockwave boundary layer interaction, compressible boundary layer transition and compressible baseflows.

**PROGRESS**

- 1) Investigation of the flow over a micro-ramp in a Mach 2 turbulent boundary layer by means of TOMO-PIV.
- 2) Investigation of transonic buffeting on rocket afterbodies. The unsteady flow field over a generic rocket after-body was studied by means of high speed PIV. Furthermore, measurements were performed on a 1:60 scale of an Ariane V launcher using HS-PIV within an ESA technical research program (TRP).
- 3) Development of nano-scale tracer particles for use in high speed compressible flows
- 4) Investigation of Görtler vortices in a Mach 7.5 double compression ramp flow.

**DISSERTATIONS**

1. Schrijer, FFJ (27-01-2010). Experimental investigation of re-entry aerodynamic phenomena. TU Delft (129 pag.) (Oisterwijk: Proefschriftenmaken.nl); prom.: Dr. F Scarano. (TUD).
2. Souverein, LJ (15-03-2010). On the scaling and unsteadiness of shock induced separation. TU Delft and Univ. Provence Aix-Marseille; prom.: Prof. PG Bakker (TUD), Prof. JP Dussauge (UPAM). ISBN 978-90-9025203-2.

**SCIENTIFIC PUBLICATIONS**

1. Ghaemi, S, Schmidt-Ott, A & Scarano, F (2010). Nanostructured tracers for laser-based diagnostics in high-speed flows. *Measurement science & technology*, 21 (3)(105403), 1-10.
2. Ragni, D, Schrijer, FFJ, Oudheusden, BW van & Scarano, F (2010). Particle tracer response across shocks measured by PIV. *Experiments in fluids*.
3. Schrijer, FFJ (2010). Investigation of Gortler vortices in a hypersonic double compression ramp flow by means of infrared thermography. *Quantitative infrared thermography journal*, 7(2).
4. Schrijer, FFJ & Bannink, WJ (2010). Description and Flow Assessment of the Delft Hypersonic Ludwig Tube. *Journal of spacecraft and rockets*, 47(1 (125-133)).
5. Schrijer, FFJ & Modenini, D (2010). Inverse Heat Transfer Measurements in a Supersonic Wind tunnel: Application to a Backward Facing Step. In L Ronchi Abbozzo (Ed.), *Proceedings of the 10th International Workshop on Advanced Infrared Technology and Applications (AITA 2009)*. Florence: AITA.
6. Schrijer, FFJ, Sciacchitano, A & Scarano, F (2010). Experimental investigation of flow control devices for the reduction of transonic buffeting on rocket afterbodies. In C Tropea & R Adrian (Eds.), *Proceedings of the 15th Int. Symposium on Applications of Laser Techniques to Fluid Mechanics* (pp. 1-12). Lisboa: 15th Int. Symp. on ALTFM.

7. Schrijer, FFJ & Walpot, LMGFM (2010). Experimental Investigation of the Supersonic Wake of a Reentry Capsule. AIAA-2010-1251. In Proceedings of the 48th AIAA Aerospace Sciences Meeting Including the New Horizons Forum and Aerospace Exposition. Orlando: AIAA.
8. LJ Souverein, P Dupont, JF Debiève, JP Dussauge, BW van Oudheusden, F Scarano (2010). Effect of interaction strength on unsteadiness in shock-wave-induced separations, *AIAA Journal* 48, 1480–1493.

**PROJECT LEADERS**

M Gerritsma

**RESEARCH THEME**

Mathematical and computational methods for fluid flow analysis

**PARTICIPANTS**

J Kreeft, A Palha, M Gerritsma

**COOPERATIONS**

Caltech, Sandia Nat. Labs.

**FUNDED**

STW, FCT (Portugese Funding Agency)

University	-
FOM	-
STW	100%
NWO Other	-
Industry	-
TNO	-
GTI	-
EU	-
Scholarships	-

**START OF THE PROJECT**

2008

**INFORMATION**

M Gerritsma

015 278 5903

M.I.Gerritsma@TUDelft.nl

**PROJECT AIM**

When discrete operators commute with continuous operators, the discrete system 'behaves as' the continuous system one wants to approximate. Commutation implies strict conservation and stability. The continuous world is described in terms of differential geometry, whereas the discrete setting is in terms of algebraic topology.

**PROGRESS**

A discrete compatible framework has been developed where all basic operations from differential geometry (exterior derivative, Hodge operator, wedge operator, Lie derivative) are consistently defined. Codes have been developed which corroborate the theoretical derivations.

**DISSERTATIONS**

-

**SCIENTIFIC PUBLICATIONS**

1. Mimetic least-squares spectra/hp finite element methods for the Poisson equations, A. Palha, M. Gerritsma, Lecture Notes in Computer Science, 5910, LNCS, pp. 662-670, 2010.
2. Least-squares spectral element methods on staggered grids, M. Gerritsma, M. Bouman and A. Palha, Lecture Notes in Computer Science, 5910 LNCS, pp. 653-661, 2010.
3. A conservative Spectral Element Methods for Curvilinear Domains, Mick Bouman, Artur Palha, Jasper Kreeft and Marc Gerritsma, In: Spectral and High Order Methods for Partial Differential Equations, Ed. Jan S. Hesthaven and Einar M. Ronquist, Lecture notes in Computational Science and Engineering, 76, pp 111-120, 2010.
4. Edge functions for Spectral Element Methods, Marc Gerritsma, In: Spectral and High Order Methods for Partial Differential Equations, Ed. Jan S. Hesthaven and Einar M. Ronquist, Lecture notes in Computational Science and Engineering, 76, pp 199 - 208, 2010.
5. Spectral element Approximation of the Hodge-star Operator in Curved Elements. Artur Palha and Marc Gerritsma, In: Spectral and High Order Methods for Partial Differential Equations, Ed. Jan S. Hesthaven and Einar M. Ronquist, Lecture notes in Computational Science and Engineering, 76, pp 283-292.

**PROJECT AIM**

Novel non-intrusive experimental approaches are developed and applied to determine the aerodynamic loads on objects from flow velocity data measured with particle image velocimetry (PIV). This is achieved by combining the flow field information with basic momentum principles. Apart from looking at the fundamental principles (notably 3D flow effects) the project will also address the development of practical procedures. The primary area of application is in low-speed aerodynamics and industrial fluid dynamics. The extension of the method to the high-speed flow regime will also receive attention, in view of its relevance for industrial aeronautics.

**PROGRESS**

1) Completion of the comparative assessment of the computation of instantaneous pressure from time-resolved PIV velocimetry data. A combined analysis was made using theoretical predictions and a numerical simulation (“synthetic experiment”). Verification with experimental investigation of a bluff body (square cross-section prism) in which acquisition of both planar and volumetric (“thin-tomo”) PIV data were carried out, to assess the impact of 3D flow information. Theoretical investigation and assessment of different pressure integration schemes.

2) Determination of pressure fields and integral loads under compressible flow conditions: extension to the study of sectional loads on a propeller blade, based on phase-locked multiple-plane stereo-PIV (cooperation with DNW).

**DISSERTATIONS**

-

**SCIENTIFIC PUBLICATIONS**

1. R. de Kat, R.A. Humble, B.W. van Oudheusden: Time-resolved PIV study of a transitional shear-layer around a square cylinder, IUTAM Symposium on Bluff-Body Wakes and Vortex Induced Vibrations, BBVIV-6, Capri, Italy, 22-25 June 2010, 4 pp.
2. R. de Kat, B.W. van Oudheusden: Instantaneous planar pressure from PIV: analytical and experimental test-cases, 15th Int. Symposium on Applications of Laser Techniques to Fluid Mechanics, Lisbon, Portugal, 5-8 July, 2010, 11 pp.

**PROJECT LEADERS**

BW van Oudheusden, F Scarano

**RESEARCH THEME**

Complex dynamics of fluids

**PARTICIPANTS**

R de Kat, D Ragni

**COOPERATIONS**

DNW, NLR

**FUNDED**

SenterNovem, EOSLT-04001 (INNWIND)

University -

FOM -

STW 100%

NWO Other -

Industry -

TNO -

GTI -

EU -

Scholarships -

**START OF THE PROJECT**

2006

**INFORMATION**

BW van Oudheusden

015 278 5349

B.W.vanOudheusden@tudelft.nl

www.tudelft.nl/

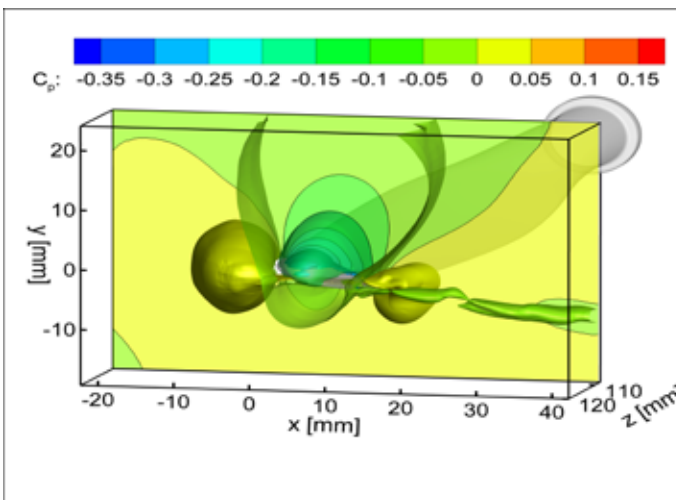

Three-dimensional pressure field in the tip region of a propeller blade

**PROJECT LEADERS**

H Bijl, R Dwight

**RESEARCH THEME**

Mathematical and computational methods for fluid flow analysis

**PARTICIPANTS**

J de Baar, (A Sciacchitano)

**COOPERATIONS**

Tata Steel Europe, Lotus Renault GP, Uni Liverpool, Uni Duisburg-Essen

**FUNDED**

STW	
University	-
FOM	-
STW	100%
NWO Other	-
Industry	-
TNO	-
GTI	-
EU	-
Scholarships	-

**START OF THE PROJECT**

2010

**INFORMATION**

R Dwight  
r.p.dwight@tudelft.nl  
aerodynamics.lr.tudelft.nl/~rdwight/

**PROJECT AIM**

To develop methodologies for combining numerical simulation and experimental data, in order to exploit their complementary strengths. The foundation of the methodologies will be previous successful developments in uncertainty quantification and Bayes theorem. Applications include:

- Using high-fidelity NS simulations to fill gaps in experimental data - e.g. to evaluate pressure from PIV velocity fields, to increase temporal and spatial resolution of PIV data.
- Using experimental data to probabilistically calibrate turbulence model parameters. With the obtained pdf representations of the parameters, the implied solution error due to turbulence modeling discrepancy becomes available.
- Using simulation to investigate unexpected features of experimental results for complex fluid-structure interaction problems, where many variables are poorly controllable.

**PROGRESS**

- Calibration has been performed on a structure-frame test case, where the goal was to determine structural variability across samples from indirect measurements. To be published in MSSP.
- Identification of structural parameters of a coupled fluid-structure test case with the potential to undergo flutter, given only data about the linear response of the coupled system. To be published in Computers+Fluids.
- Assimilation of PIV data into an FEM simulation for simple 3d test cases - using a Least-squares FEM code. Publication below.
- Development of co-Kriging approaches incorporating both gradient and error information. Theoretical results regarding the robustness and stiffness of the resulting response surfaces. To be published in J. Royal Society B.

**DISSERTATIONS**

-

**SCIENTIFIC PUBLICATIONS**

1. Richard P Dwight, "Bayesian inference for data assimilation using Least-Squares Finite Element methods", 2010 IOP Conf. Ser.: Mater. Sci. Eng. 10 012224.

### PROJECT AIM

To develop efficient prediction methods for wall-bounded turbulent flows using variational multiscale large-eddy simulation (VMS-LES) and goal-oriented reduced-order modelling techniques.

### PROGRESS

1) The performance of three-scale VMS-LES discretizations using standard and multiscale approaches to wall modeling have been demonstrated.

2) A h-p steering technique for goal-oriented adaptation was developed for use within a multiscale discontinuous Galerkin (MDG) method. MDG methods provide similar advantages to standard discontinuous Galerkin techniques but exploit local problems to reduce the number of global degrees of freedom. A similar local strategy for h-p steering was shown to be very effective.

3) A semi-continuous formulation for goal-oriented reduced-order modeling was developed. Unlike previous formulations, its extension to non-linear operators and functionals is clear. Successful computations have been demonstrated for the latter.

### DISSERTATIONS

-

### SCIENTIFIC PUBLICATIONS

1. Hulshoff, S. J., Munts, E. A. and Labrujere, J.: Wall-stress boundary conditions for variational-multiscale LES. International Journal for Numerical Methods in Fluids doi: 10.1002/flid.2311.
2. Hulshoff, S. J., Munts, E. A. and Labrujere, J.: Refinement with Wall Modelling in Spectral-Element LES, Direct and Large-Eddy Simulation VII ERCOFTAC Series, 2010, Volume 13, Part 2, 201-204.

### PROJECT LEADERS

SJ Hulshoff, H Bijl

### RESEARCH THEME

Mathematical and computational methods for fluid flow analysis

### PARTICIPANTS

P Fick, S Mattei, W Edeling,  
L Chen, L Cheng

### COOPERATIONS

University of Texas, Austin

### FUNDED

STW, Chinese Scholarship Council (CSC)

University 25%

FOM -

STW 10%

NWO Other -

Industry -

TNO -

GTI -

EU -

Scholarships 65%

### START OF THE PROJECT

2008

### INFORMATION

SJ Hulshoff

015 278 1538

S.J.Hulshoff@TUDelft.NL

www.Ir.tudelft.nl/aerodynamics



## NEW SIMULATION TECHNIQUES FOR FLOWS INTERACTING WITH TRANSFORMING STRUCTURES

### PROJECT LEADERS

H Bijl, AH van Zuijlen

### RESEARCH THEME

Mathematical and computational methods for fluid flow analysis

### PARTICIPANTS

J Kreeft, V Kazemi Kamyab

### COOPERATIONS

Tata Steel, Philips. Numeca Int.

### FUNDED

STW

University -

FOM -

STW 100%

NWO Other -

Industry -

TNO -

GTI -

EU -

Scholarships 65%

### START OF THE PROJECT

2008

### INFORMATION

JJ Kreeft

015 278 4215

[j.j.kreeft@tudelft.nl](mailto:j.j.kreeft@tudelft.nl)

Vahid Kazemi-Kamyab

015 278 3939

[V.KazemiKamyab@tudelft.nl](mailto:V.KazemiKamyab@tudelft.nl)

[www.aero.lr.tudelft.nl](http://www.aero.lr.tudelft.nl)

### PROJECT AIM

Development, implementation and application of revolutionary, but generic, numerical algorithms for problems where gas or fluid flows interact with material structures being cooled through a phase transformation. Material properties change dramatically due to phase transformation and, as a result, so does the interaction between the materials structure and the flow. This interaction of multi-physics and multi-scale is present in industrial applications like the continuous casting of steel slabs. New simulation techniques are required for the accurate, robust and fast simulation of such problems.

### PROGRESS

An automated coarse level acceleration technique is developed to increase the speed to solve multi-physics problems with strong mechanical or thermal coupling. Compared to previous research the automated strategy determines by itself if and which coarse grid level is suitable for performing a coarse level correction step. Secondly the thermal coupling between domains, when solved in a partitioned manner, is analyzed in combination with high order time integration schemes. When the Dirichlet and Neumann coupling conditions are applied in the right order, loosely coupled problems can be integrated in a robust and efficient way with high order multi-stage time integration. For strongly coupled problems sub-iterations are still required.

### DISSERTATIONS

-

### SCIENTIFIC PUBLICATIONS

-

# EFFICIENT NAVIER STOKES BASED SIMULATION OF NON-LINEAR AEROELASTICITY AND VALIDATION OF THE AEROELASTIC SOLVER BY MEANS OF EXPERIMENTS

## PROJECT AIM

To couple a Navier Stokes based flow solver (RANS) to a non-linear aeroelastic structural model, whereby the main focus is on improving the accuracy of the solution and reduce the computational time in order to enable aeroelastic RANS computations for wind turbines. Furthermore, validation of the aeroelastic solver is a key-issue.

## PROGRESS

In the first two project years two experiments have been conducted: one to assess the unsteady flow about a rigid wing with oscillating flap and a second aeroelastic experiment to investigate fluid structure interactions for a wing having 1 degree of freedom (DOF) with oscillating flap. The post-processing of both experiments has been taken care of and preparations have been made to setup a subsequent aeroelastic experiment. On the numerical part, Theodorsens model, a 2D panel code and an unsteady Reynolds-averaged Navier Stokes solver are coupled to a structural model. A first series of computations is performed according to the experimental test case.

## DISSERTATIONS

-

## SCIENTIFIC PUBLICATIONS

1. R.C.J. Lindeboom, J.J.H.M. Sterenborg, and C.Simao. Determination of unsteady loads on a du96w180 airfoil with actuated flap using particle image velocimetry. In The Science of making Torque from Wind, 2010.

## PROJECTLEADERS

H Bijl

## RESEARCHTHEME

Mathematical and computational methods for fluid flow analysis

## PARTICIPANTS

JJHM Sterenborg, H Bijl, AH van Zuijlen

## COOPERATIONS

Numeca International, ECN, WMC

## FUNDED

SenterNovem, EOSLT-04001

(INNWIND)

University -

FOM -

STW -

NWO Other 100%

Industry -

TNO -

GTI -

EU -

Scholarships -

## START OF THE PROJECT

2008

## INFORMATION

JJHM Sterenborg

015 278 1231

[j.j.h.m.sterenborg@tudelft.nl](mailto:j.j.h.m.sterenborg@tudelft.nl)



Prof.dr.ir. GS Stelling



Prof.dr.ir. WSJ Uijttewaal

The Environmental Fluid Mechanics Group performs fundamental, process-oriented research on fluid flow problems of practical relevance in water management, environmental engineering, hydraulic engineering and coastal engineering. To enhance the potential of practical applications, the section not only aims at writing publications, as far as scientific output is concerned, but also at the production of software that is available via internet. An example is the software package SWAN (Simulating Waves Nearshore). Free surface flow models based upon unstructured grids are in preparation and will be released in coming years. Within this philosophy the research program encompasses the following main items:

- Free surface waves with topics such as: Generation and prediction of squall oscillations and harbour seiches, dynamics of surf beat and the Wave model SWAN
- Shallow flows, transport and sedimentation with the following topics: turbulence and flow structures in rivers and its flood planes, stability and transport under waves and currents of rock elements in cover layers consisting of loose, granular material,
- Transport of suspended particulate matter with topics such as: advanced, experimental and numerical work concerning particle-turbulence interaction as well as flocculation and sedimentation processes
- Numerical model development with topics such as: development of the non-hydrostatic models for the investigation of dam breaks including inundations, short wave problems, near field plume discharges, stratified flows, and local scour near dams, unstructured grids via finite volume methods and finite element methods and development of large scale integrated 1d/2d rainstorm drainage/flooding model applicable to rural and urban areas.

### PROJECT AIM

The research program aims at gaining insight into the physics of bend flows and improving engineering tools, by means of a combined experimental-numerical (EPF Lausanne – TU Delft) research methodology. Main goals of the numerical part (LES) are the completing of the data from the experimental part (pressure fields and shear stresses), the broadening of the parameter space (mainly towards physical relevant geometries, like rivers) and the investigation and parameterisation of the results.

### PROGRESS

The present research on curved open-channel flows finished recently. Many simulations have been performed of these kind of flows, for many geometric and hydraulic conditions. The focus of the research has mainly been on features of the secondary flow, the bed shear stresses and turbulence. The simulations were of the LES-type and were conducted using a finite-volume numerical code with an Immersed Boundary Method incorporated to be able to deal with complex geometries (see figure 1). The results have extensively been validated with experimental data and have led to a broad image of curved open-channel flows in general. This, hereby, also facilitates further development of sound physics-based parameterizations of key bend flow phenomena.

### DISSERTATIONS

1. W. van Balen, Curved open-channel flows – A numerical study, PhD thesis, TU Delft, 2010.

### SCIENTIFIC PUBLICATIONS

1. W. van Balen, K. Blanckaert and W.S.J. Uijttewaal (2010), Analysis of the role of turbulence in curved open-channel flow at different water depths by means of experiments, LES and RANS, J. Turbulence. 11 N12.
2. W. van Balen, W.S.J. Uijttewaal and K. Blanckaert (2010), Large-eddy simulation of a curved open-channel flow over topography, Phys. Fluids. 22, 075108.

### PROJECTLEADERS

WSJ Uijttewaal, GS Stelling

### RESEARCHTHEME

Complex structures of fluids

### PARTICIPANTS

W van Balen

### COOPERATIONS

-

### FUNDED

STW	
University	-
FOM	-
STW	100%
NWO Other	-
Industry	-
TNO	-
GTI	-
EU	-
Scholarships	-

### START OF THE PROJECT

2005

### INFORMATION

WSJ Uijttewaal

W.S.J.Uijttewaal@tudelft.nl

015 278 1371

**PROJECT LEADERS**

C Chassagne

**RESEARCH THEME**

Complex dynamics of fluids

**PARTICIPANTS**

-

**COOPERATIONS**

CNRL (Canada)

**FUNDED**

CNRL (Canada)

University -

FOM -

STW -

NWO Other -

Industry 100%

TNO -

GTI -

EU -

Scholarships -

**START OF THE PROJECT**

2011

**INFORMATION**

C Chassagne

c.chassagne@tudelft.nl

**PROJECT AIM**

The aim of the project is to get a deeper understanding in the processes responsible for the stability and flocculation behavior of fine sediment suspensions (tailings) from oil industry. These tailings should be disposed of in the most efficient way possible. This study includes:

- electrokinetic studies to determine the stability of the suspensions and get information about the surface charge of the sediment particles and flocculant adsorption onto this surface
- particle size distribution as a function of time, added flocculant concentration and shear flow
- ESEM, DLS and X-ray studies to determine the composition/shape/size of the particles.

**PROGRESS**

Pilot experiments have been successfully performed in 2010. The project is starting 01-02-2011.

**DISSERTATIONS**

-

**SCIENTIFIC PUBLICATIONS**

-

## PROJECT AIM

Since the Indian Ocean Tsunami many countries have contributed to the development of tsunami warning systems in the Indian Ocean. A German-Indonesian Tsunami Early Warning System (GITEWS) ([www.gitews.de](http://www.gitews.de)), is currently under active development. One of the aims of this project is the development of accurate numerical models with which to simulate the propagation, flooding and drying, and run-up of a tsunami. This is done not only for forecasting purposes, but also for detailed scenario studies, in order to assess the regions most at risk from future tsunamis.

## PROGRESS

An unstructured grid, finite volume ocean model has been developed which is suitable for flooding and drying problems. The new model is efficient, does not produce non-physical negative water depths and generate accurate results for a wide variety of flooding and drying problems. A paper on this new model has been published. Non-hydrostatic implementation is under developing.

## DISSERTATIONS

-

## SCIENTIFIC PUBLICATIONS

1. Cui, H., Pietrzak, J.D. and Stelling, G.S., 2010. A finite volume analogue of the PINC - P1 finite element, with accurate flooding and drying. *Ocean Model.*, 35, 16-30.

## PROJECT LEADERS

GS Stelling

## RESEARCH THEME

Mathematical and computational methods for fluid flow analysis

## PARTICIPANTS

Haiyang Cui, Dr. J.D. Pietrzak, Prof. Dir. Ir. G.S. Stelling

## COOPERATIONS

Alfred Wegener Institute for Polar and Marine Research

## FUNDED

Alfred Wegener Institute for Polar and Marine Research

University 25%

FOM 50%

STW -

NWO Other -

Industry 25%

TNO -

GTI -

EU -

Scholarships -

## START OF THE PROJECT

2008

## INFORMATION

Haiyang Cui

015 278 85433

H.Cui@tudelft.nl

**PROJECT LEADERS**

GS Stelling, JD Pietrzak

**RESEARCH THEME**

Mathematical and computational methods for fluid flow analysis

**PARTICIPANTS**

O Kleptsova, JD Pietrzak, GS Stelling

**COOPERATIONS**

-

**FUNDED**

Speerpunt Water

University 25%

FOM 50%

STW -

NWO Other -

Industry 25%

TNO -

GTI -

EU -

Scholarships -

**START OF THE PROJECT**

2005

**INFORMATION**

O Kleptsova

O.Kleptsova@TUDelft.nl

**PROJECT AIM**

The project aims to develop a new coastal model based on unstructured grids. The model is to be suitable for the investigation of flow phenomena, such as the development and behavior of river plums and associated transport processes in the Dutch and other coastal zones. New discretization of the shallow water equations are being developed and deeper insight gained into the numerical properties and modeling capabilities of this new class of models.

**PROGRESS**

A new unstructured grid fine resolution tidal model of the southern North Sea including the Rhine-Scheldt Delta region was developed. The model is able to correctly reproduce the essential characteristics of the M2 tide. The simulated velocity field was used to evaluate the Simpson-Hunter stratification criterion.

Previously developed advection was used for detailed simulation of the Indian Ocean tsunami of 2004 including flooding of Banda Aceh region.

Deeper insight gained into tangential velocity reconstruction procedure in the presence of multiple z-layer case.

**DISSERTATIONS**

-

**SCIENTIFIC PUBLICATIONS**

1. O. Kleptsova, G. S. Stelling and J. D. Pietrzak. An accurate momentum advection scheme for a z-level coordinate models. OCEAN DYNAMICS, Volume 60, Issue 6, 1447–1461, 2010.

## FLOC SIZE DISTRIBUTION AND SETTLING VELOCITY OF COHESIVE SEDIMENT

### PROJECT AIM

Cohesive sediments flocculate and generate a distribution of differently sized flocs. The small fraction of this distribution, microflocs, is mainly responsible for light extinction and turbidity while the large one, macroflocs, plays a major role in sediment settling and harbor and waterways siltation. The aim of this research is to investigate the physical and chemical processes leading to flocculation. The effect of all influencing factors such as the physico-chemical properties of the sediment and of the suspension and the hydrodynamic conditions are investigated both numerically and experimentally.

### PROGRESS

A Population Balance Equation (PBE) has been developed to model the flocculation process. The PBE models the processes of aggregation and breakup and includes two parameters which have been tuned using the results of the jar tests performed in the first part of the project. The parameter for aggregation, i.e. the sticking probability of particles after collision, was found to increase with the zeta-potential of the particles decreasing in absolute value. The same trend has been observed for the ratio between the parameters for aggregation and breakup. The zeta-potential is a measure for the charge of the particles: when their charge decreases, particles are more likely to flocculate.

### DISSERTATIONS

1. Francesca Mietta, PhD thesis "Evolution of the floc size distribution of cohesive sediments", TU Delft (2010).

### SCIENTIFIC PUBLICATIONS

1. On the behavior of mud floc size distribution: model calibration and model behavior, Ocean Dynamics, 2010.

### PROJECT LEADERS

GS Stelling, JC Winterwerp

### RESEARCH THEME

Complex dynamics of fluids

### PARTICIPANTS

F Mietta, C Chassagne, JC Winterwerp, GS Stelling, WSJ Uijtewaal

### COOPERATIONS

Deltares

### FUNDED

STW	
University	-
FOM	-
STW	100%
NWO Other	-
Industry	-
TNO	-
GTI	-
EU	-
Scholarships	-

### START OF THE PROJECT

2009

### INFORMATION

C Chassagne  
015 278 5970  
c.chassagne@tudelft.nl



#### PROJECT LEADERS

HJ de Vriend, WSJ Uijttewaal

#### RESEARCH THEME

Mathematical and computational methods for fluid flow analysis

#### PARTICIPANTS

W Ottevanger (PhD student), K Blanckaert (supervisor), CJ Sloff (supervisor)

#### COOPERATIONS

Deltares (Netherlands), EPFL (Switzerland), IGB (Germany)

#### FUNDED

STW/NWO	
University	-
FOM	-
STW	100%
NWO Other	-
Industry	-
TNO	-
GTI	-
EU	-
Scholarships	-

#### START OF THE PROJECT

2008

#### INFORMATION

W Ottevanger  
015 278 4069  
w.ottevanger@tudelft.nl

#### PROJECT AIM

Development of a quasi-3D morphodynamic model which is valid for sharply curved river bends, such that high spatial and temporal scales may be simulated. Subsequently, the quasi-3d model will be validated using laboratory and field measurements, as well as more detailed software models (LES, RANS). Finally the model will be used for fundamental research into the processes (momentum redistribution, secondary flow, bank and bed shear stresses) and the dynamics (river bed adaptation, bank erosion and accretion, planform development) of meandering rivers (at high curvature).

#### PROGRESS

The processes governing velocity redistribution in sharp river bends were analyzed for three sharply curved flume and field measurement data sets using a 1D flow model valid for high curvature. An extension of Delft3D for hydrodynamic modelling in sharp bends using a quasi-3D approach has been developed and validated. The new approach includes the saturation of secondary flow at high curvature, increased roughness due to curvature and the bed shear stress angle adaptation. These processes are important with regards to the morphological development in sharply curved meander bends, which is presently under investigation.

#### DISSERTATIONS

-

#### SCIENTIFIC PUBLICATIONS

1. Ottevanger, W., Uijttewaal, W. S. J. & Blanckaert, K. Validation of a non-linear reduced hydrodynamic model for curved open-channel flow. River Flow 2010 - Dittrich, Koll, Aberle & Geisenhainer (eds) - © 2010 Bundesanstalt für Wasserbau ISBN 978-3-939230-00-7 pp. 1049-1057, September 7-10, Braunschweig.
2. Ottevanger, W., Uijttewaal, W. S. J. & Blanckaert, K. (2010). Mechanisms influencing the redistribution of streamwise momentum in sharply curved open-channel flow. Proceedings NCR days, November 4-5, Amsterdam.

**PROJECT AIM**

Present state of the art wave models are still insufficiently accurate regarding shallow water dissipation and non-linear interactions in the coastal zone. This project will focus on three main areas; improvement of modelling capabilities of physical processes in the coastal zone, procurement, utilisation and dissemination of high quality datasets and the development, testing and dissemination of new source terms for third generation wave models.

**PROGRESS**

Calibration of a new source term for wave breaking is being completed and a test bed of a number of laboratory and field cases have been selected for verification. These cases will be added to the ONR testbed for utilisation and dissemination. Analysis of spectral evolution is being carried out by USACE and Shell IEP.

**DISSERTATIONS**

-

**SCIENTIFIC PUBLICATIONS**

-

**PROJECT LEADERS**

GPh van Vledder, JL Hanson,  
LH Holthuijsen, KC Ewans

**RESEARCH THEME**

Mathematical and computational  
methods for fluid flow analysis

**PARTICIPANTS**

D Hurdle, M Zijlema, M Christou,  
K Hathaway, J Salmon

**COOPERATIONS**

Arcadis NL/Alkyon Hydraulic  
Consultancy & Research, US  
Army Corps of Engineers, Shell  
International Exploration and  
Production

**FUNDED**

Office of Naval Research, USA	
University	-
FOM	-
STW	-
NWO Other	-
Industry	100%
TNO	-
GTI	-
EU	-
Scholarships	-

**START OF THE PROJECT**

2010

**INFORMATION**

G Ph van Vledder  
015 278 3255  
g.p.vanvledder@tudelft.nl

**PROJECT LEADERS**

WSJ Uijtewaal, GS Stelling

**RESEARCH THEME**

Complex dynamics of fluids

**PARTICIPANTS**

Shahid Ali

**COOPERATIONS**

Deltares, RWS

**FUNDED**

NUFFIC

University -

FOM -

STW -

NWO Other -

Industry -

TNO -

GTI -

EU -

Scholarships 100%

**START OF THE PROJECT**

2007

**INFORMATION**

Shahid Ali

015 278 5974

S.Ali@tudelft.nl

**PROJECT AIM**

The River flow within flood plains is difficult to forecast because of the complex flow geometry founded by main channel and groyne fields. In the flood plane there are many obstacles and landforms, which requires high demand for numerical modeling. Due to large computational domain and limitation of computer capacity, complete details can generally not be resolved. This study focuses on correct representation of resistance elements in a numerical simulation and consistent behavior towards high water stages. A number of processes related to vegetation, weirs and bed-forms will be studied in great detail in order to come to an improved implementation of physical processes.

**PROGRESS**

A Literature study about the current modeling approach and their performances is being carried out. The energy head loss due to submerged and emerged vegetated dikes and groynes has been modeled by The expansion loss form drag model and has been compared with the experimental data. A series of Experiments has been performed in the Laboratory of Environmental Fluid Mechanics of Delft University of Technology. In these experiments blockage due to vegetation has been varied and different shapes of vegetation and groynes have been tested. Experiments to investigate the structure of the flow over the oblique vegetated groynes and other complex phenomena related to it have been performed. The numerical simulations of the rapidly varying flow over the vegetated groynes are in progress.

**DISSERTATIONS**

-

**SCIENTIFIC PUBLICATIONS**

1. Ali, S, Uijtewaal, W.S.J. (2009). "Form drag due to vegetated weir-like obstacles interpreted as expansion losses" Proceedings of the 33rd IAHR Congress on water engineering for sustainable environment, Vancouver, British Columbia, Canada.
2. Ali, S, Uijtewaal, W.S.J.(2010). "Flow resistance due to the vegetated weir-like obstacles during high water stages" Proceedings of river flow 2010 Braunschweig Germany.

A typical cross section of the lowland rivers in the Netherlands

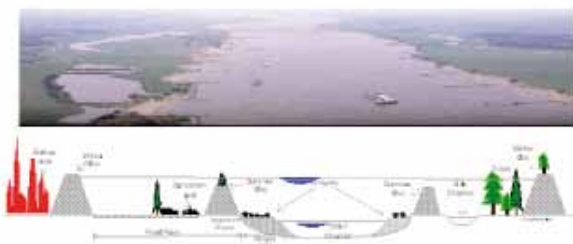

## SIMULATING WAVES TILL SHORE (SWASH)

### PROJECT AIM

The long term goal is the development of the SWASH (Simulating WAves till SHore) model for describing complex changes to rapidly varied flows and wave transformations in coastal waters.

### PROGRESS

A computational procedure has been developed for simulating non-hydrostatic, free surface, rotational flows. The governing equations are the nonlinear shallow water equations including non-hydrostatic pressure. The computational algorithm combines efficiency and robustness allowing application to large-scale, real-life problems. Its implementation in the publicly available SWASH (<http://swash.sf.net>) is intended to be used for predicting wave transformation in both surf and swash zones due to nonlinear wave-wave interactions, interaction of waves with currents, and wave breaking as well as runup at the shoreline, and rapidly varied shallow water flows typically found in coastal flooding resulting from e.g. dike breaks and tsunamis. The code has been validated against various laboratory data. The SWASH code has been parallelized and performance experiments on different parallel platforms revealed good run time reduction.

### DISSERTATIONS

-

### SCIENTIFIC PUBLICATIONS

-

### PROJECTLEADERS

G Stelling, M Zijlema

### RESEARCHTHEME

Mathematical and computational methods for fluid flow analysis

### PARTICIPANTS

PB Smit

### COOPERATIONS

-

### FUNDED

TUD	
University	100%
FOM	-
STW	-
NWO Other	-
Industry	-
TNO	-
GTI	-
EU	-
Scholarships	-

### START OF THE PROJECT

2010

### INFORMATION

M Zijlema

015 278 3255

[m.zijlema@tudelft.nl](mailto:m.zijlema@tudelft.nl)

<http://swash.sf.net>

**PROJECT LEADERS**

LH Holthuijsen

**RESEARCH THEME**

Mathematical and computational methods for fluid flow analysis

**PARTICIPANTS**

GS Stelling, LH Holthuijsen, M Zijlema, TT Janssen, PB Smit

**COOPERATIONS**

University of Notre Dame, Indiana;  
San Francisco State University, California.

**FUNDED**

Office of Naval Research	
University	-
FOM	-
STW	-
NWO Other	-
Industry	100%
TNO	-
GTI	-
EU	-
Scholarships	-

**START OF THE PROJECT**

2006

**INFORMATION**

LH Holthuijsen  
015 278 4803  
L.H.Holthuijsen@tudelft.nl

**PROJECT AIM**

The project aim is to develop a conceptual extension of spectral energy wave models to be able to capture spatial inhomogeneities in the wavefield ( due to f.i. diffraction, refraction ) and to improve present formulations for the triad wave-wave interactions. Furthermore, to allow for an extreme flexibility in spatial resolution, the present spectral wave model SWAN is implemented on an unstructured computational grid ( SWANus). The first application of such a grid is, in cooperation with the University of Notre Dame, a coupling with the ocean circulation model ADCIRC to improve the hurricane prediction capability for New Orleans.

**PROGRESS**

The tight coupling between ADCIRC and SWAN on a common unstructured grid has been completed; the resulting model is validated for hurricanes Katrina and Rita demonstrating efficient performance using 3,062 computational cores. A combination of theoretical and practical problems have convinced us to no longer pursue a model based upon two ( weakly-) coupled spectral evolution equations for wave energy and phase. Instead, we capture the effect of spatial inhomogeneity using a single evolution equation – derived from first principles - for the Coupled mode spectrum which includes a lowest order approximation for spatial inhomogeneities and reduces to the classical radiative transport equation for homogeneous conditions.

**DISSERTATIONS**

-

**SCIENTIFIC PUBLICATIONS**

1. Dietrich, J. C., M. Zijlema, et al. (2010). "Modeling hurricane waves and storm surge using integrally-coupled, scalable computations." Coastal Engineering 58(1): 45-65.
2. Dietrich, J. C., J.J. Westerink, et al. (2010). "Hurricane Gustav (2008) Waves and Storm Surge: Hindcast, Synoptic Analysis and Validation in Southern Louisiana" Monthly Weather Review.

**PROJECT AIM**

This project combines laboratory experiments, detailed numerical simulations and field measurements on river bends in order to link the physical processes related to hydrodynamics and morphodynamics to the biological processes. It is aimed at extending the ecological modelling approach with hydrodynamic parameters.

**PROGRESS**

Field studies have been performed on three different river bends. Bed levels, detailed velocity patterns and distribution of invertebrates and vegetation over the width of the bend have been obtained. Parallel to this the numerical modelling of flow and transport is being adapted to include ecological parameters.

**DISSERTATIONS**

-

**SCIENTIFIC PUBLICATIONS**

1. Sukhodolov, A. N., & Uijttewaal, W. S. J. (2010). Assessment of a river reach for environmental fluid dynamics studies. *Journal of Hydraulic Engineering*, 136(11), 880-888.

**PROJECT LEADERS**

WSJ Uijttewaal

**RESEARCH THEME**

Complex dynamics of fluids

**PARTICIPANTS**

W Ottevanger, K Blanckaert,  
I Schnauder, A Sukhodolov

**COOPERATIONS**

IGB Berlin Germany

**FUNDED**

NWO	
University	-
FOM	-
STW	-
NWO Other	100%
Industry	-
TNO	-
GTI	-
EU	-
Scholarships	-

**START OF THE PROJECT**

2009

**INFORMATION**

WSJ Uijttewaal

015 278 1371

W.S.J.Uijttewaal@tudelft.nl

**PROJECT LEADERS**

GS Stelling, BC van Prooijen

**RESEARCH THEME**

Mathematical and computational methods for fluid flow analysis

**PARTICIPANTS**

ND Volp

**COOPERATIONS**

NIOO, Deltares, Rijkswaterstaat

**FUNDED**

Ecoshape	
University	-
FOM	-
STW	-
NWO Other	-
Industry	100%
TNO	-
GTI	-
EU	-
Scholarships	-

**START OF THE PROJECT**

2009

**INFORMATION**

ND Volp  
015 278 4069  
n.d.volp@tudelft.nl

**PROJECT AIM**

The objective of the project is to improve the morphodynamic modeling of intertidal areas, focusing on model improvement and better model usage. As the morphodynamic and hydrodynamic processes cover a wide range of time and length scales, a multiple-scale approach is required. Typical challenges in model improvement are the proper computation of velocities in shallow water areas and coupling between hydrodynamics and morphodynamics on the different length and time scales.

**PROGRESS**

The subgrid method of Casulli 2009 is combined with the physics-based distribution (PBD) method. The subgrid method of Casulli uses small scale bathymetry information for simulations on a coarser grid. The PBD method implies the use of the small scale bathymetry information, including variations in bottom roughness, to determine the friction for computations on a coarse grid. This combination of methods allows for an accurate modeling of the flow including the flooding and drying of intertidal areas. It also allows for an accurate reconstruction of the velocity field on the subgrid, which can be used to compute bed shear stresses to determine sediment transport. The results show a significant increase in accuracy, with only a slight increase in computation cost.

**DISSERTATIONS**

-

**SCIENTIFIC PUBLICATIONS**

-







Prof.dr.ir. AA Darhuber



Prof.dr.ir. F Toschi



Prof.dr.ir. MEH van Dongen (em)

In 2006 prof. M.E.H. (Rini) van Dongen retired as head of the research group Gas Dynamics and obtained emeritus status. In 2007 prof. Anton Darhuber was appointed as his successor. Prof. A. (Mico) Hirschberg was interim leader of the group Gas Dynamics in 2006 and 2007. On January 1, 2008 the research group Gas Dynamics was officially renamed into Mesoscopic Transport Phenomena (MTP). On January 1, 2009 the head of the group Low-Temperature Physics (LTE) prof. A.T.A.M. (Fons) de Waele retired and LTE became a part of MTP. Therefore, currently three major lines of research coexist in MTP: the first corresponds to the activities of the former group Gas Dynamics, i.e. research on aero-acoustics and condensation phenomena; the second involves fluid dynamics at small lengthscales, where interfacial typically dominate over inertial effects. The third corresponds to the activities of the former group Low-Temperature Physics, i.e. research on thermo-acoustics.

In September 2008, prof. Federico Toschi was appointed professor in the Department of Applied Physics and became a member of MTP. He is working in the field of statistical physics, fluid dynamical turbulence and micro-/nanofluidics. In February 2009, Jens Harting was appointed Assistant Professor in the group MTP. His expertise rests with large-scale Lattice Boltzmann simulations of suspension dynamics as well as micro- and meso-scale flows.

The research activities related to gas dynamics concern the study of wave phenomena in gases. Aero-acoustics is the study of the interaction between sound and flows. The research concerns the study of wave generation by elementary processes in flows, with the focus on confined flows and sound generation by vortices. This work has many important industrial applications. Condensation phenomena are studied using gas-dynamical devices such as expansion wave tubes to obtain fundamental information about the physics of nucleation and droplet growth in complex gas mixtures. This involves the development of models for the properties of molecular clusters in the nanometer range at extreme conditions far below the freezing point, for which bulk liquid properties are unknown.

Research in the area of micro- and nano-fluidics comprises both fundamental and application-inspired topics ranging from fluid physics at nano-scales to manufacturing processes of optoelectronic devices. Current and commencing projects concern dip- and die-coating of chemically patterned substrates, flows driven by temperature and concentration gradients, as well as flows involving phase changes.

Research activities of the former group LTE concern pulse-tube refrigeration, thermoacoustics, and vortex cooling. These topics have a common thermodynamic and hydrodynamic background. They provide cooling without moving parts in the cold regions of the system. All topics address new physical questions in gas dynamics with the aim of unraveling basic working principles.

**PROJECT AIM**

A system of colloidal particles suspended in two immiscible fluids (water and oil) will be considered. There will be used the lattice Boltzmann method to simulate the two fluids, the suspended particles will be simulated by molecular dynamics. The shape of the particles will be ellipsoidal, rodlike platletlike and cylindrical. Furthermore, Janus particles will be investigated.

**PROGRESS**

Improvements of particle-particle interactions for anisotropic particles in multiphase flow haven been proposed and single/few particles systems are currently under investigation.

**DISSERTATIONS**

-

**SCIENTIFIC PUBLICATIONS**

-

**PROJECTLEADERS**

J Harting

**RESEARCHTHEME**

Mathematical and computational methods for fluid flow analysis

**PARTICIPANTS**

Florian Günther

**COOPERATIONS**

STW

**FUNDED**

STW

University -

FOM -

STW 100%

NWO Other -

Industry -

TNO -

GTI -

EU -

Scholarships -

**START OF THE PROJECT**

2010

**INFORMATION**

J Harting

040 247 3766

j.harting@tue.nl

F Günther

040 247 5140

f.s.guenther@tue.nl

**PROJECT LEADERS**

J Harting

**RESEARCH THEME**

Mathematical and computational methods for fluid flow analysis

**PARTICIPANTS**

Sebastian Schmieschek

**COOPERATIONS**

University of Stuttgart

**FUNDED**

University of Stuttgart  
University 100%  
FOM -  
STW -  
NWO Other -  
Industry -  
TNO -  
GTI -  
EU -  
Scholarships -

**START OF THE PROJECT**

2009

**INFORMATION**

S Schmieschek  
040 247 4215  
s.m.p.schmieschek@tue.nl

**PROJECT AIM**

Development and application of the software LB3D for problems of fluid flows of multiple phases as well as multiple components in confined, complex geometries. Research focuses on a better understanding of models for non-ideal and complex fluid mixtures and the implementation and improvement of boundary conditions to enable more realistic simulations of contact line dynamics.

**PROGRESS**

Applications of a high Knudsen enabled LB scheme to dilute gas flows in complex geometries. Successful simulations of binary mixtures in porous media, calculations of relative permeabilities. Research and improvement of boundary conditions towards a more realistic model of wetting behaviour. Application and improvement of boundary conditions to phenomenological model systems exhibiting surface slip.

**DISSERTATIONS**

-

**SCIENTIFIC PUBLICATIONS**

-

**PROJECT AIM**

To find out whether ferromagnetic particles can be a suitable alternative to conventional EOR techniques, and whether pulsed electromagnetic fields could be used to drive these particles to preferred regions. To have control over the movement of the particles will be a major advantage of the proposed method.

**PROGRESS**

The oil position is one focused on numerical simulations. Permeabilities of digitized rock geometries have been calculated, paving the way for better characterization of realistic porous media as found in nature (and oil fields in particular). Spinodal decomposition of two fluids inside such a porous medium have been studied qualitatively. Pickering emulsions and 'bijels' have been quickly revisited, to allow the oil to get some feeling for the matter. Currently, the behaviour of a single droplet (stabilized by particles) is being considered. Parameters currently under investigation are the number of particles used in the system, varying strengths of the interaction between fluids and particles and strength of a shear imposed upon the system.

**DISSERTATIONS**

-

**SCIENTIFIC PUBLICATIONS**

1. Testud P., Auregan Y., Moussou P. & Hirschberg A. , The whistling potentiality of an orifice in a confined flow using an energetic criterion, J. Sound and Vibration, 325, 769-780 (2009).

**PROJECT LEADERS**

J Harting, A Steeb

**RESEARCH THEME**

Complex structures of fluids

**PARTICIPANTS**

SCJ Frijters

**COOPERATIONS**

Shell-FOM IPP

**FUNDED**

Shell-FOM IPP

University -

FOM 100%

STW -

NWO Other -

Industry -

TNO -

GTI -

EU -

Scholarships -

**START OF THE PROJECT**

2010

**INFORMATION**

J Harting

040 247 3766

jharting@tue.nl

www.harting.ws

**PROJECT LEADERS**

AA Darhuber, F Toschi

**RESEARCH THEME**

Complex dynamics of fluids

**PARTICIPANTS**

A Hirschberg, MEH van Dongen

**COOPERATIONS**

X. Pelorson (Gipsa, fr), A.M. van Hirtum (Gipsa, fr), J.Gilbert (LAUM, fr), B. Fabre (LAM, fr), A. Barney (ISVR, UK).

**FUNDED**

CNRS	
University	100%
FOM	-
STW	-
NWO Other	-
Industry	-
TNO	-
GTI	-
EU	-
Scholarships	-

**START OF THE PROJECT**

1998

**INFORMATION**

A.Hirschberg  
040 247 2163  
A.Hirschberg@tue.nl

**PROJECT AIM**

Using in-vitro experiments we study the effects of the interaction between air flow and oscillations of flexible walls at conditions relevant for speech and cough. Goal is the development of physical models which can support the diagnostics of pathologies by means of signal analysis.

**PROGRESS**

A review paper has been written for Annual Review of Fluid Mechanics (Aeroacoustics of Musical instruments) including a discussion of voice production.

**DISSERTATIONS**

-

**SCIENTIFIC PUBLICATIONS**

-

# FLOW-INDUCED PULSATIONS IN GAS TRANSPORT SYSTEMS : PREDICTION, PREVENTION AND INFLUENCE ON VOLUME FLOW MEASUREMENTS

## PROJECT AIM

The quantitative prediction of unsteady shedding of vortices in confined flows and of the interaction of these vortices with acoustic waves. Prediction of self-sustained flow-instabilities in high-pressure gas transport systems and the impact of such instabilities on volume-flow measurements. Recently the focus of the project has shifted to fundamental aspects of the design of mufflers and the whistling of corrugated pipes. Main focus is the detailed modeling of the flow at corrugations. Applications range from musical toys to oscillation in water level of rivers with groynes.

## PROGRESS

Within the European project Aether, the study of grazing flow along perforated walls has been extended to the case of mixed grazing-bias flow. Also the aero-acoustical response of complex pipe systems with closed side-branches has been considered. Systems of 15 undep side-branches and 6 deep side-branches have been studied. Within a STW project the whistling of corrugated pipes has been studied. Firstly a parametric study has been carried out to determine the effect of flow velocity, corrugation geometry, static pressure and pipe length. Secondly a theoretical model has been developed, which is based on the numerical simulation of the response of a single cavity by means of an incompressible laminar flow model. The model predicts within 2% the Strouhal number for self-sustained oscillation. The amplitude of the oscillations are overestimated by a factor 4. Thirdly a model has been developed to predict the sound radiation by a corrugated pipe used as musical toy, the "hummer". Sound is produced by swirling the pipe over the head while holding it at one end. The sound pattern is determined by the interference of the sound radiated by the two open pipe terminations.

## DISSERTATIONS

-

## SCIENTIFIC PUBLICATIONS

1. Tonon, D. , Willemst, J.F.H., Hirschberg, A., Föller, S , Polifke, W Flow-induced pulsations in double closed branch systems,16th AIAA/CEAS Aeroacoustics Conference (31st AIAA Aeroacoustics Conference) 2010, Article number 2010-3930.
2. Nakiboglu G, Belfroid SPC, Willems JFH, Hirschberg A., Whistling behavior of periodic systems: Corrugated pipes and multiple side branch system, Int. J. Mechanical Sciences, 52, 1458-1470 (2010).
3. Nakiboglu G, Belfroid SPC, Tonon D, Willems JFH, Hirschberg A. A parametric study on the whistling of multiple side branch system as a model for corrugated pipes, American Society of Mechanical Engineers, Pressure Vessels and Piping Division (Publication) PVP ,Volume 4, 2010, Pages 389-398.
4. Tonon D, Landry BJT, Belfroid SPC, Willems JFH, Hofmans GCJ, Hirschberg A. Whistling of a pipe system with multiple side branches: Comparison with corrugated pipes, J. Sound and Vibration, 329, 1007-1024 (2010).
5. Kooijman G, Hirschberg A, Auregan Y, Influence of mean flow profile and geometrical ratios on scattering of sound at a sudden area expansion in a duct, J. Sound and Vibration, 329, 607-626 (2010).

## PROJECT LEADERS

AA Darhuber, F Toschi

## RESEARCH THEME

Complex dynamics of fluids

## PARTICIPANTS

A Hirschberg, MEH van Dongen, HWM HOeijmakers, JFH Willems, FMR van Uittert, H Manders, E de Cocq, D. Tonon, G. Nakiboglu, O Rudenko, L Minelli (Bsc trainee Poli. Torino),

## COOPERATIONS

UTwente, Kema, TNO, Shell, NLR, VKI, ASML, EDF, LAUM (Université du Maine, fr), LMS (Be), University of Cambridge, Cerfac (fr), TU Munchen, KU IEuven, LTU (Lulea, Sw), IST (Lisbon), Rolls Royce (UK)

## FUNDED

FOM	
University	25%
FOM	-
STW	50%
NWO Other	-
Industry	-
TNO	-
GTI	-
EU	25%
Scholarships	-

## START OF THE PROJECT

1983

## INFORMATION

A Hirschberg  
040 247 2163  
A.Hirschberg@tue.nl

#### PROJECT LEADERS

AA Darhuber

#### RESEARCH THEME

Complex dynamics of fluids

#### PARTICIPANTS

AA Darhuber, BJ Brasjen, JA Vieyra Salas

#### COOPERATIONS

Holst Centre Eindhoven

#### FUNDED

DPI	
University	25%
FOM	-
STW	-
NWO Other	-
Industry	-
TNO	-
GTI	-
EU	-
Scholarships	75%

#### START OF THE PROJECT

2007

#### INFORMATION

AA Darhuber  
a.a.darhuber@tue.nl

#### PROJECT AIM

The investigation and optimization of the hydrodynamics of die-coating to fabricate active layers of organic light emitting diodes (OLEDs) of uniform thickness and composition based on solution-processing. Means to enhance the influence of surface energy patterns at high coating speeds will be explored as well as methods for mitigation and elimination of evaporation-driven material redistribution.

#### PROGRESS

Experiments re. evaporation of nominally pure liquids on chemically patterned surfaces were conducted and results agree qualitatively with numerical simulations. Numerical simulations have been performed to calculate the evaporative flux in the gas phase using a prescribed height profile and in the liquid phase to obtain the dynamic evolution of the height profile with a prescribed evaporative flux. A self-consistent simulation coupling both domains is in progress. We conducted experiments regarding dip- and die-coating of chemically patterned surfaces. We performed numerical simulations regarding the dewetting dynamics on these surfaces to study the influence on film thickness homogeneity over large areas.

#### DISSERTATIONS

-

#### SCIENTIFIC PUBLICATIONS

1. J. A. Vieyra Salas, A. A. Darhuber. Evaporation of liquids on chemically patterned surfaces. *Chemical Engineering & Processing: Process Intensification* published online, doi:10.1016/j.cep.2010.09.009.
2. B. J. Brasjen, A. A. Darhuber. Dip-coating of chemically patterned surfaces *Chemical Engineering & Processing: Process Intensification*. published online, doi:10.1016/j.cep.2010.09.021.
3. B. Brasjen, A. A. Darhuber. Coating and stability of thin liquid films on chemically patterned surfaces. *Proceedings 15th Int. Coating Science & Technology Symp. (Minneapolis, 12-15 Sept. 2010)*.
4. J. A. Vieyra Salas, A. A. Darhuber. Evaporation of thin liquid films on chemically patterned surfaces. *Proceedings 15th Int. Coating Science & Technology Symp. (Minneapolis, 12-15 Sept. 2010)*.

### PROJECT AIM

Systematic investigation and modeling of the surfactant induced flows at micro- and nanoscales. Quantification of the spreading dynamics of surfactants on liquid films in various geometries, ranging from simple test cases to natural porous media. Development of strategies how to use surfactants to increase oil recovery rates.

### PROGRESS

Using both experiments and numerical simulations, we studied surfactant spreading on thin liquid films deposited on chemically patterned surfaces. On liquid rivulets, upon which a droplet of surfactant is deposited, a rim develops in the rivulet height profile that is moving away from the deposited surfactant droplet. It is located just behind the leading edge of the surfactant, and to good approximation the rim position  $x_{\text{rim}}(t)$  follows a power law behavior  $x_{\text{rim}} \sim t^a$ , where the spreading exponent  $a$  quantifies the displacement efficiency of a given surfactant. Experiments conducted for both soluble and insoluble surfactants are in quantitative agreement with the numerical simulations.

### DISSERTATIONS

-

### SCIENTIFIC PUBLICATIONS

1. M. Hanyak, D. Sinz, A. A. Darhuber. Surfactant spreading on thin liquid films on chemically patterned surfaces. Proceedings Int. Conference on Multiphase Flow 2010 (May/June 2010, Tampa, Florida).
2. D. Sinz, M. Hanyak, A. A. Darhuber. Self-propulsion of surfactant droplets on inclined liquid films. Proceedings Int. Conference on Multiphase Flow 2010 (May/June 2010, Tampa, Florida).

### PROJECT LEADERS

AA Darhuber

### RESEARCH THEME

Complex dynamics of fluids

### PARTICIPANTS

AA Darhuber, Myroslava Hanyak,  
David Sinz

### COOPERATIONS

Shell International Exploration and  
Production B.V.

### FUNDED

STW, TU/e, Shell University	25%
FOM	-
STW	65%
NWO Other	-
Industry	10%
TNO	-
GTI	-
EU	-
Scholarships	-

### START OF THE PROJECT

2008

### INFORMATION

AA Darhuber  
a.a.darhuber@tue.nl



## DEWETTING OF ULTRATHIN WATER LAYERS ON HYDROPHOBIC SURFACES

### PROJECT LEADERS

AA Darhuber

### RESEARCH THEME

Complex dynamics of fluids

### PARTICIPANTS

AA Darhuber, J Zeegers,

C Berendsen

### COOPERATIONS

ASML

### FUNDED

FOM

University -

FOM 50%

STW -

NWO Other -

Industry 50%

TNO -

GTI -

EU -

Scholarships -

### START OF THE PROJECT

2010

### INFORMATION

AA Darhuber

a.a.darhuber@tue.nl

### PROJECT AIM

The aim of this project is to study the physics of dewetting of submicron thick aqueous layers on partially wetting surfaces. The evaporation of these films causes technological difficulties, as cooling due to the large latent heat of evaporation of water leads to inhomogeneous thermal contractions of substrates. At the focus is the question whether the dewetting and break-up process of the water layer into droplets can be influenced regarding the size distribution and arrangement of the resulting droplets.

### PROGRESS

A numerical model for the dynamics of spontaneous and induced break-up of model liquids has been developed. An experimental setup for dry-spot nucleation induced by an air-jet has been built and systematic experiments can now commence. A second setup for temperature-gradient-induced dry-spot nucleation has been designed and is currently being finalized.

### DISSERTATIONS

-

### SCIENTIFIC PUBLICATIONS

-

**PROJECT AIM**

Characterization and optimization of solution-based growth of organic semiconductor crystals.

**PROGRESS**

We investigated of the morphology of solution-based crystal growth in the vicinity of receding contact lines of a volatile solvent. We systematically study the influence of coating speed, solution concentration and evaporation conditions and were able to support the experimental results by scaling relations. Semiconductor devices fabricated by means of dip-coating exhibited a systematic dependence of mobility on the coating parameters. Near-record-mobilities were achieved.

**DISSERTATIONS**

-

**SCIENTIFIC PUBLICATIONS**

1. Rogowski, RZ; Darhuber, AA. Crystal Growth near Moving Contact Lines on Homogeneous and Chemically Patterned Surfaces. LANGMUIR Volume: 26 Issue: 13 Pages: 11485-11493 Published: 2010.

**PROJECTLEADERS**

AA Darhuber

**RESEARCHTHEME**

Complex dynamics of fluids

**PARTICIPANTS**

AA Darhuber, R Rogowski

**COOPERATIONS**

Holst Centre Eindhoven, Dick Broer and Cees Bastiaansen, Dept. of Chem. Eng. & Chemistry, TU/e N. Stingelin-Stutzman, Imperial College, London, UK

**FUNDED**

DPI	
University	25%
FOM	-
STW	-
NWO Other	-
Industry	-
TNO	-
GTI	-
EU	-
Scholarships	75%

**START OF THE PROJECT**

2009

**INFORMATION**

AA Darhuber

a.a.darhuber@tue.nl

**PROJECT LEADERS**

J Zeegers

**RESEARCH THEME**

Complex dynamics of fluids

**PARTICIPANTS**

R Liew, J Zeegers

**COOPERATIONS**

-

**FUNDED**

STW

University -

FOM -

STW 80%

NWO Other -

Industry 20%

TNO -

GTI -

EU -

Scholarships -

**START OF THE PROJECT**

2009

**INFORMATION**

J Zeegers

040 247 4212

j.c.h.zeegers@tue.nl

**PROJECT AIM**

Developing a vortex tube swirling flow system to separate condensate out of gas flow.

**PROGRESS**

Apparatus has been bought to do measurements. Currently we are building up equipment to start measurements.

**DISSERTATIONS**

-

**SCIENTIFIC PUBLICATIONS**

-

## MICROCOOLER

### PROJECT AIM

Design, analysis and development of a small scale thermoacoustic traveling wave cooler.

### PROGRESS

The project itself has ended in 2010 and a PhD thesis is being written at this moment. Promotion is expected to take place later this year (probably October)

### DISSERTATIONS

-

### SCIENTIFIC PUBLICATIONS

-

### PROJECTLEADERS

J Zeegers, HJM ter Brake

### RESEARCHTHEME

Complex dynamics of fluids

### PARTICIPANTS

Y Li, J Zeegers, HJM ter Brake

### COOPERATIONS

-

### FUNDED

MicroNed	
University	-
FOM	-
STW	-
NWO Other	100%
Industry	-
TNO	-
GTI	-
EU	-
Scholarships	-

### START OF THE PROJECT

2005

### INFORMATION

J Zeegers

040 247 4212

[j.c.h.zeegers@tue.nl](mailto:j.c.h.zeegers@tue.nl)

## HIGH AMPLITUDE OSCILLATORY GAS FLOW IN INTERACTION WITH SOLID BOUNDARIES

### PROJECT LEADERS

J Zeegers

### RESEARCH THEME

Complex dynamics of fluids

### PARTICIPANTS

P Aben

### COOPERATIONS

STW

### FUNDED

STW

University -

FOM -

STW 80%

NWO Other -

Industry 20%

TNO -

GTI -

EU -

Scholarships -

### START OF THE PROJECT

2005

### INFORMATION

J Zeegers

040 247 4212

j.c.h.zeegers@tue.nl

### PROJECT AIM

The goal of this project was to understand the interaction of high amplitude acoustic waves with solid boundaries as it takes place in thermoacoustic engines. Effects of non-linearities, and vortex shedding so called fluid structure interaction has been investigated.

### PROGRESS

This project has ended in 2010.

### DISSERTATIONS

1. Paul Aben, High-amplitude thermoacoustic flow interacting with solid boundaries.

### SCIENTIFIC PUBLICATIONS

-

## DROPLET BREAKUP IN HOMOGENEOUS AND ISOTROPIC TURBULENCE

### PROJECT AIM

Droplet emulsions are key to many natural and industrial processes. In presence of an external flow, droplets undergo deformation, breakup and coagulation. In a turbulent flow, breakup of droplets larger than the Kolmogorov scale is governed by the interplay between the surface tension force and turbulent fluctuations. We study the breakup of droplets in a stationary homogeneous and isotropic flow. We consider droplets with the same density of the transporting fluid. The droplets and the fluid are numerically modeled by means of a multicomponent Lattice-Boltzmann method. The turbulent fluid is maintained through a large scale stirring force. The radius of stable droplets is larger than the Kolmogorov scale and the interface thickness smaller than the Kolmogorov scale.

### PROGRESS

The figure below shows clearly the droplet deformation, break-up and aggregation at different times during the simulation. At dilute droplet concentration limit we verify the Kolmogorov-Hinze criteria. The dataset has also been used to study the probability distribution function of the droplet radius in the statistically stationary droplets dispersion at different volume fraction.

### DISSERTATIONS

-

### SCIENTIFIC PUBLICATIONS

1. F. Toschi, P. Perlekar, L. Biferale, and M. Sbragaglia, Droplet breakup in homogeneous and isotropic turbulence, arXiv:1010.1795.

### PROJECT LEADERS

F Toschi

### RESEARCH THEME

Mathematical and computational methods for fluid flow analysis

### PARTICIPANTS

Prasad Perlekar

### COOPERATIONS

Prof. L. Biferale, Univ. Tor Vergata, Italy. Dr. M. Sbragaglia, Univ. Tor Vergata, Italy

### FUNDED

TUE	
University	100%
FOM	-
STW	-
NWO Other	-
Industry	-
TNO	-
GTI	-
EU	-
Scholarships	-

### START OF THE PROJECT

2010

### INFORMATION

F Toschi

040 247 3911

f.toschi@tue.nl

A droplet immediately after a breakup event



### PROJECT LEADERS

F Toschi, J Harting

### RESEARCH THEME

Mathematical and computational methods for fluid flow analysis

### PARTICIPANTS

F Janoschek (PhD student)

F Mancini (guest MSc student)

R Kusters (BSc student)

### COOPERATIONS

ACB Bogaerds, FN van de Vosse (Biomed. eng.); PD Anderson, HEH Meijer (Mech. eng.)

### FUNDED

TU/e High Potential Research Program (2009)

University 100%

FOM -

STW -

NWO Other -

Industry -

TNO -

GTI -

EU -

Scholarships -

### START OF THE PROJECT

2009

### INFORMATION

F Toschi

040 247 3911

f.toschi@tue.nl

J Harting

040 247 3766

j.harting@tue.nl

<http://mtp.phys.tue.nl>

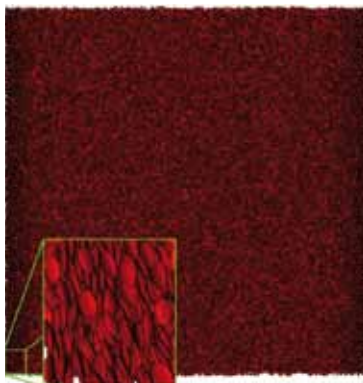

### PROJECT AIM

Blood may be treated as a dense suspension of red blood cells in blood plasma. Typical length scales vary over several orders of magnitude. Current computational models treat blood as a homogeneous fluid or model a limited number of cells at high resolution. Our aim is to bridge the gap between both approaches with a simplified yet still particulate method of high efficiency. We will develop phenomenological cell-cell and cell-wall interaction models based on experimental and numerical work done by other groups on the single-cell level and provide a link to flow properties at larger scales which might be used to improve continuous blood models.

### PROGRESS

In 2010, we presented our approach of a coarse-grained model for computational hemodynamics to a broader scientific audience by means of our first journal publication and presentations at several international conferences. The computing resources granted by DEISA at the end of the previous year allowed to perform many large-scale simulations: we tested a new technique for viscosity measurement in Kolmogorov flow, studied tube flow of blood under various conditions and investigated the rotational behavior of cells in shear flow. The latter work was performed as part of a MSc thesis. In a BSc project, our model was extended to account for the tank-treading motion of the cell membrane in simple 2D shear flows. Further work was carried out on the improvement of the short range interactions of cells in our model. This work will be continued during the next months.

### DISSERTATIONS

1. Numerical studies on statistical properties of red blood cell-like particles. F. Mancini. MSc thesis, University of Rome "Tor Vergata" & Eindhoven University of Technology (2010).
2. Tank-treading motion of an ellipsoidal particle in a Couette flow. R. Kusters. BSc thesis, Eindhoven University of Technology (2010).

### SCIENTIFIC PUBLICATIONS

1. Simplified particulate model for coarse-grained hemodynamics simulations. F. Janoschek, F. Toschi, J. Harting. *Physical Review E* 82, 056710 (2010).
2. Rotational behavior of red blood cells in suspension---a mesoscale simulation study. F. Janoschek, F. Mancini, J. Harting, F. Toschi. *Phil. Trans. R. Soc. London Series A* (in press; 2010).
3. Hemodynamics at the mesoscale: a coarse-grained lattice Boltzmann-molecular dynamics approach. F. Janoschek, J. Harting, F. Toschi. *Proc. 5th Europ. Conf. Comp. Fluid Dynamics (ECCOMAS CFD 2010; 2010)*.
4. Mesoscale hemodynamics with coarse-crained lattice Boltzmann-molecular dynamics simulations. F. Janoschek, J. Harting, F. Toschi. *Proc. 5th Int.Conf. Multiscale Materials Modeling (MMM2010; 2010)*.

## POPULATION DYNAMICS IN TURBULENT FLOWS

### PROJECT AIM

Population dynamics deals with the study of birth, death and growth processes of biological species. These processes are severely affected by the local ecosystems, by the presence of nutrients, and by the local population density. Turbulence is normally known to increase mixing and diffusion; but, remarkably, population dynamics in a turbulent environment shows localization (e.g. patchy regions of planktons on the ocean surface). The aim of the present project is to study the interplay of these two mechanisms to understand population dynamics of species in turbulent environments.

### PROGRESS

We have performed a study of population dynamics of single species in a model turbulent surface flow. Our study quantifies the role of turbulence on the patchiness of the turbulent population (see Fig. 1) as well as the effect of compressibility. After these preliminary studies we plan to investigate the role of discrete fluctuations to understand the effect of turbulence on the fixation time of mutations.

### DISSERTATIONS

-

### SCIENTIFIC PUBLICATIONS

1. P. Perlekar, R. Benzi, D.R. Nelson, and F. Toschi, Population Dynamics at High Reynolds number, Phys. Rev. Lett. 105, 114501 (2010).

Pseudo-color plot of population concentration in a model for compressible turbulent surface flow. The dark green indicates regions of high population concentration whereas white indicate low population concentration.

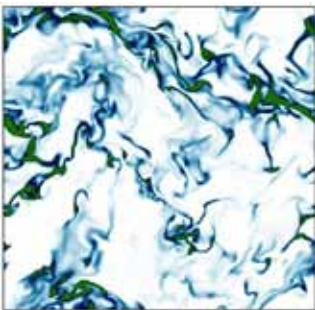

### PROJECT LEADERS

F Toschi

### RESEARCH THEME

Mathematical and computational methods for fluid flow analysis

### PARTICIPANTS

P Perlekar, F Toschi

### COOPERATIONS

Prof. R. Benzi, Univ. Tor Vergata, Italy. Prof. D.R. Nelson, Harvard University, USA

### FUNDED

TUE	
University	100%
FOM	-
STW	-
NWO Other	-
Industry	-
TNO	-
GTI	-
EU	-
Scholarships	-

### START OF THE PROJECT

2009

### INFORMATION

F Toschi

040 247 3911

f.toschi@tue.nl



**PROJECT LEADERS**

F Toschi

**RESEARCH THEME**

Mathematical and computational methods for fluid flow analysis

**PARTICIPANTS**

S Srivastava

**COOPERATIONS**

ASML, Océ

**FUNDED**

FOM

University -

FOM 100%

STW -

NWO Other -

Industry -

TNO -

GTI -

EU -

Scholarships -

**START OF THE PROJECT**

2009

**INFORMATION**

F Toschi

040 247 3911

f.toschi@tue.nl

**PROJECT AIM**

The project aims at the development, validation and use of the lattice-Boltzmann method for the simulation of various geometries where contact line dynamics is relevant. These problems arise due to the complex geometric structure of the geometry, like in the immersion lithography and the ink-jet printhead.

**PROGRESS**

In order to study the dynamics of advancing contact line in the immersion lithography problem, we started working on the plunging plate problem. The plunging plate problem in 2D involves the study of contact line instabilities when a solid wettable plate is pushed in side a liquid bath. We are using multiphase D2Q9 lattice Boltzmann method based on Shan-Chen model for the direct simulation of the problem. The contact line speed is measured in terms of capillary number

$$Ca = U\mu/\gamma$$

Our simulations are in agreement with the theory that the viscous dissipation rate is maximum close to the contact line and negligible away from the contact line.

**DISSERTATIONS**

-

**SCIENTIFIC PUBLICATIONS**

-

Figure shows the velocity field (liquid on the left and vapor on the right) close to the contact line; colours shows the log value of the viscous dissipation rate. Here the plate (at bottom) was moving horizontally towards left (Capillary number was  $Ca = 0.16$ ). Equilibrium contact angle ( $Ca=0$ ) was 45 degree and viscosity ratio was 0.17.

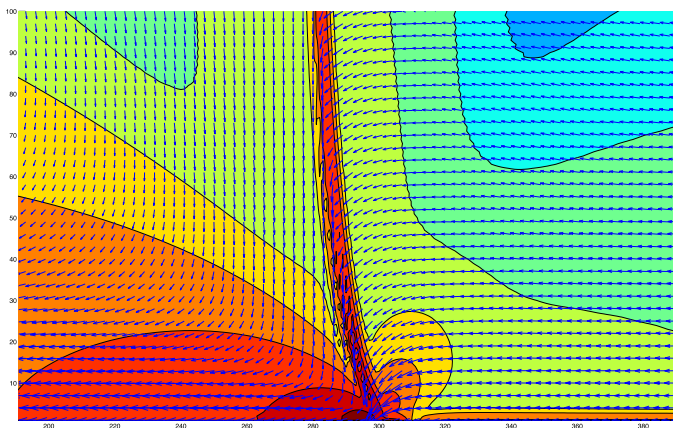





Prof.dr.ir. GJF van Heijst



Prof.dr. HJH Clercx



Prof.dr. H Kelder



Prof.dr.ir. BJ Geurts

The research in this section concerns transport phenomena, in particular as occurring in turbulent flows. An important line of approach is that vortex dynamics, in which elementary processes are studied in rather isolated configurations. Special attention is given to the influence of body forces associated with background rotation and density stratification. Such situations are met in industrial settings and also within the framework of geophysical fluid dynamics. In addition to transport in turbulent flows, the dynamics of granular media and 3D viscous mixing is studied.

The following main lines of research can be distinguished:

1. Spectral and transport properties of 3D turbulence
2. Dispersion in quasi-2D turbulence
3. Atmospheric physics
4. Granular media and viscous mixing

In most of these themes the research approach is a combination of laboratory experiments, numerical simulation, and theoretical modelling.

**PROJECT AIM**

It is the aim of this research project to develop a better insight in the role of stratification on fluid particle dispersion by direct numerical simulation of forced stratified turbulence with constant mean background density gradient. Additionally, the role of the dispersion of either heavy (aerosols) or light (plankton) inertial particles in forced stratified turbulence will be investigated.

**PROGRESS**

This project has been finished with the thesis by M. van Aartrijk (Oct. 2008).

**DISSERTATIONS**

-

**SCIENTIFIC PUBLICATIONS**

1. Aartrijk, M. van & H.J.H. Clercx - Vertical inertial particle dispersion in stably stratified turbulence: the influence of the Basset force. *Phys. Fluids* 22, 013301 1-9 (2010).
2. Aartrijk, M. van & H. J.H. Clercx - The dynamics of small inertial particles in weakly stratified turbulence. *J. Hydro-envir. Res.* 4, 103-114 (2010).
3. Aartrijk, M. van & H.J.H. Clercx - Dispersion of (light) inertial particles in stratified turbulence. In: *Direct and Large-Eddy Simulation VII*, eds. V. Armenio, B.J. Geurts, and J. Frohlich, Springer Netherlands, pp. 455-461 (2010).
4. Hinsberg, M.A.T. van, J.H.M. ten Thije Boonkkamp & H.J.H. Clercx - An efficient, second order method for the approximation of the Basset history force. CASA Report No. 10-45, Eindhoven: Technische Universiteit Eindhoven (2010).

**PROJECTLEADERS**

HJH Clercx

**RESEARCHTHEME**

Complex dynamics of fluids

**PARTICIPANTS**

M van Aartrijk, W Kramer,  
HJH Clercx

**COOPERATIONS**

Prof V Armenio (Univ. Trieste, Italy),  
Prof E Meiburg (UCSB, USA), Dr  
JHM ten Thije Boonkkamp (TU/e-W),  
Dr KB Winters (Scripps, USA).

**FUNDED**

NWO-VICI	-
University	-
FOM	-
STW	-
NWO Other	100%
Industry	-
TNO	-
GTI	-
EU	-
Scholarships	-

**START OF THE PROJECT**

2004

**INFORMATION**

HJH Clercx  
040 247 2680  
h.j.h.clercx@tue.nl  
www.fluid.tue.nl

**PROJECT LEADERS**

GJF van Heijst, HJH Clercx

**RESEARCH THEME**

Complex dynamics of fluids

**PARTICIPANTS**RAD Akkermans, LPJ Kamp,  
RR Triefling, HJH Clercx, GJF van  
Heijst**COOPERATIONS**Prof DC Montgomery (Dartmouth  
College, USA), Dr MG Wells (Yale,  
USA), Dr L Zavala Sanson (CICESE,  
Mexico)**FUNDED**

FOM	
University	-
FOM	100%
STW	-
NWO Other	-
Industry	-
TNO	-
GTI	-
EU	-
Scholarships	-

**START OF THE PROJECT**

2005

**INFORMATION**GJF van Heijst  
040 247 2722  
g.j.f.v.heijst@tue.nlHJH Clercx  
040 247 2680  
h.j.h.clercx@tue.nl  
www.fluid.tue.nl**PROJECT AIM**

It is the aim of this research project to develop a better insight in the spectral and transport properties of quasi-two-dimensional flows, the dynamics of vortices in shallow fluid layers, and the effects of domain boundaries (solid walls) on (quasi-)2D turbulence. For this purpose, substantial effort will be put in the further development of sophisticated flow measurement techniques such as high-resolution PTV and stereo-PIV.

**PROGRESS**

This project has been finished with the thesis of RAD Akkermans (June 2010).

**DISSERTATIONS**

1. Akkermans, R.A.D. - 3D Structures and dispersion in shallow fluid layers. PhD thesis, Eindhoven University of Technology, The Netherlands (2010).

**SCIENTIFIC PUBLICATIONS**

1. Akkermans, R.A.D., L.P.J. Kamp, H.J.H. Clercx & G.J.F. van Heijst - Three-dimensional flow in electromagnetically driven shallow two-layer fluids. Phys. Rev. E 82, 026314 1-11 (2010).
2. Kunnen, R.P.J., R.R. Triefling & G.J.F. van Heijst - Vortices in time-periodic shear flow. Theor. Comp. Fluid Dyn. 24, 315-322 (2010).
3. Tenreiro, M.L., L. Zavala Sanson, G.J.F. van Heijst & R.R. Triefling - Experiments and simulations on self-organization of confined quasi-2D turbulent flows with discontinuous topography. Phys. Fluids 22, 025101 1-14 (2010).
4. Triefling R.R., C.E.C. Dam & G.J.F. van Heijst - Dynamics of two identical vortices in linear shear. Phys. Fluids 22, 117104 1-13 (2010).

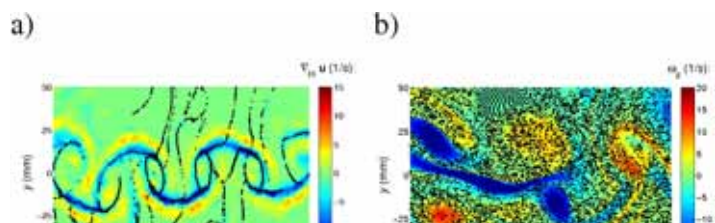

Numerically obtained snapshot of the tracer distribution, initially released on a uniform grid, on the free surface of an electromagnetically driven shallow flow (left) and in a 2D simulation with the same forcing (right). In the latter case we find a homogeneous distribution of tracers while in shallow flows the tracers collect in regions of converging flow.

## LAGRANGIAN MIXING ANALYSIS OF HEAT TRANSFER: A NEW WAY FOR THERMAL OPTIMISATION

### PROJECT AIM

Principal objective of the proposed study is an in-depth analysis of the Kenics static mixer by Lagrangian mixing analysis of heat transfer. The study is divided into two subprojects:

1. Topological mixing analysis of heat transfer in the Kenics mixer (Esubalew Demissie; Wbt)
2. Experimental heat-transfer and mixing analysis of the Kenics mixer (Ozge Baskan)

The project at Applied Physics focuses on the experimental characterisation of Lagrangian mixing properties in case studies by measurement of 3D fluid trajectories and the evolution of 3D concentration fields using advanced optical measurement techniques. Benchmarking of numerical thermal mixing analyses and testing of the prototype thermal-analysis tools for advanced data processing. Experimental performance tests of optimised Kenics mixers in the laboratory set-up and in industrial test facilities.

### PROGRESS

The project started in November 2010. A two-dimensional flow experiment has been designed and is currently being build to study heat transfer in periodically forced 2D shallow viscous flows. Numerical analysis of the thermal eigenmodes has been started.

### DISSERTATIONS

-

### SCIENTIFIC PUBLICATIONS

-

### PROJECTLEADERS

HJH Clercx

### RESEARCHTHEME

Complex dynamics of fluids

### PARTICIPANTS

O Baskan, HJH Clercx

### COOPERATIONS

Dr MFM Speetjens (TU/e-Wbt),  
MSc E Demissie (TU/e-Wbt),  
Dr G Metcalfe (CSIRO, Australia)

### FUNDED

STW	
University	-
FOM	-
STW	100%
NWO Other	-
Industry	-
TNO	-
GTI	-
EU	-
Scholarships	-

### START OF THE PROJECT

2010

### INFORMATION

HJH Clercx  
040 247 2680  
h.j.h.clercx@tue.nl  
www.fluid.tue.nl

**PROJECT LEADERS**

W van de Water, GJF van Heijst

**RESEARCH THEME**

Complex dynamics of fluids

**PARTICIPANTS**

H Bocanegra Evans, GJF van Heijst,  
W van de Water

**COOPERATIONS**

Dr NJ Dam (TU/e-Wbt).

**FUNDED**

FOM  
 University -  
 FOM 100%  
 STW -  
 NWO Other -  
 Industry -  
 TNO -  
 GTI -  
 EU -  
 Scholarships -

**START OF THE PROJECT**

2009

**INFORMATION**

W van de Water  
 040 247 3443  
 w.v.d.water@tue.nl  
 www.fluid.tue.nl

**PROJECT AIM**

We study the dynamics of droplets in a turbulent flow and concentrate on preferential concentration. The idea is to tag selected droplets in a turbulent air flow by making them glow. This is done by dissolving European chelate molecules in the droplets, illuminating them with a strong laser, and following the phosphorescent droplets using a fast intensified camera.

**PROGRESS**

The project started 1 October 2009. The basic ingredients of this challenging experiment, as shown in Fig.1, are now in place. Figure 1(b) illustrates that the phosphorescent lifetime of the tagged droplets is  $O(\text{ms})$ , which matches the Kolmogorov time of the flow and allows us to follow the motion of droplet constellations over small-eddy times. A turbulence chamber which uses synthetic jets as drivers has been fabricated. Preliminary results of the flow characterization (Fig.2) show a deviation from the ideal, homogeneous flow desired, while the isotropy reached is remarkable. Currently, the issue regarding the homogeneity of the flow is being addressed.

**DISSERTATIONS**

-

**SCIENTIFIC PUBLICATIONS**

-

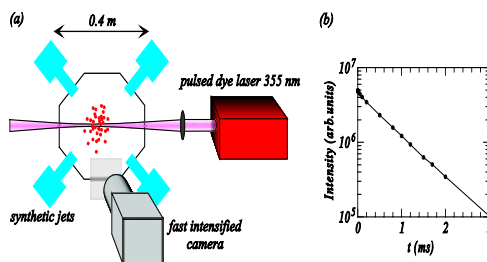

(a) Schematic view of the setup  
 (b) Decay of phosphorescence of the tagged droplets.

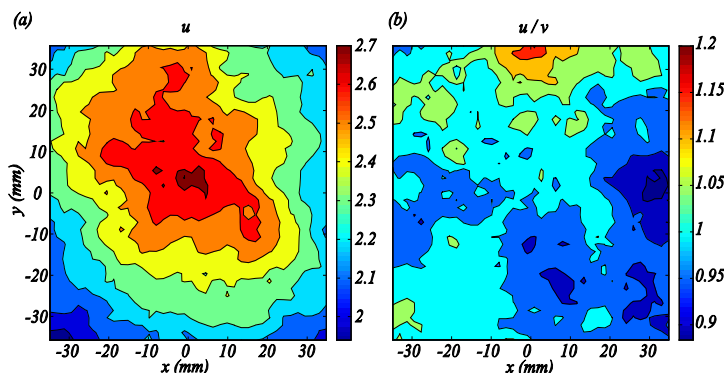

(a) Homogeneity of turbulence in the zero-mean flow turbulence chamber  
 (b) Isotropy

**PROJECT AIM**

We use an active grid to tailor turbulent flows, for example to produce the simplest anisotropic turbulent flow: homogeneous shear, to simulate the atmospheric boundary layer in a windtunnel, or to create turbulence with large Reynolds numbers.

**PROGRESS**

To make turbulence, the grid must be driven randomly. The grid consists of a regular mesh of axes with attached vanes (see Fig. 1) whose orientation is controlled by random numbers. The question is what the statistical properties of these random numbers should be to stir turbulence. We generate these random numbers using a simple turbulence model: the Gledzer-Ohkitani-Yamada (GOY) shell model. Thus we are stirring turbulence with turbulence. The random numbers (the random velocity field) generated by this model have integral time and length scales and the question is how these scales must be tuned to the wind-tunnel turbulence. As Fig. 1 illustrates, turbulence with the largest Reynolds number and which is most isotropic, must be stirred with random numbers whose integral length and time scales match those of the wind-tunnel turbulence.

**DISSERTATIONS**

-

**SCIENTIFIC PUBLICATIONS**

1. Cekli, H.E. & W. van der Water - Tailoring turbulence with an active grid. Exp. Fluids 49, 408-416 (2010).
2. Cekli, H.E., C. Tipton & W. van de Water - Resonant enhancement of turbulent energy dissipation. Phys. Rev. Lett. 105, 044503 1-4 (2010).

**PROJECTLEADERS**

W van de Water, GJF van Heijst

**RESEARCHTHEME**

Complex dynamics of fluids

**PARTICIPANTS**

HE Cekli, GJF van Heijst, W van de Water

**COOPERATIONS**

-

**FUNDED**

FOM	
University	-
FOM	100%
STW	-
NWO Other	-
Industry	-
TNO	-
GTI	-
EU	-
Scholarships	-

**START OF THE PROJECT**

2007

**INFORMATION**

W van de Water  
 040 247 3443  
 w.v.d.water@tue.nl  
 www.fluid.tue.nl

Left: A photograph of the active grid. (a) energy input in turbulence as a function of the ratio of integral time scales of windtunnel turbulence and GOY model random numbers, shown for different shell truncations of the GOY velocity field. (b) Anisotropy of wind-tunnel turbulence

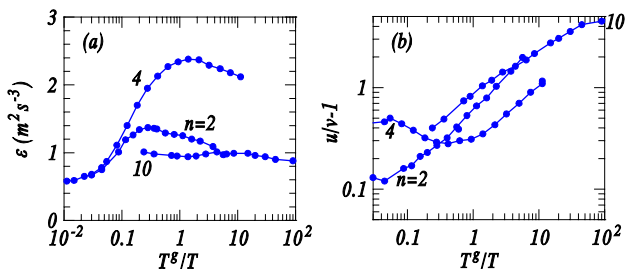



**PROJECT LEADERS**

GJF van Heijst, HJH Clercx

**RESEARCH THEME**

Complex dynamics of fluids

**PARTICIPANTS**

AR Cieslik, RAD Akkermans, LPJ  
Kamp, HJH Clercx, GJF van Heijst

**COOPERATIONS**

Prof DC Montgomery (Dartmouth  
College, USA), Dr MG Wells (Yale,  
USA)

**FUNDED**

FOM	
University	-
FOM	100%
STW	-
NWO Other	-
Industry	-
TNO	-
GTI	-
EU	-
Scholarships	-

**START OF THE PROJECT**

2005

**INFORMATION**

GJF van Heijst  
040 247 2722  
g.j.f.v.heijst@tue.nl

HJH Clercx  
040 247 2680  
h.j.h.clercx@tue.nl  
www.fluid.tue.nl

**PROJECT AIM**

It is the aim of this research project to develop a better insight in the spectral and transport properties of quasi-two-dimensional flows, the dynamics of vortices in shallow fluid layers, and the effects of domain boundaries (solid walls) on (quasi-)2D turbulence. For this purpose, substantial effort will be put in the further development of sophisticated flow measurement techniques such as high-resolution PTV and stereo-PIV.

**PROGRESS**

This project has been concluded with the thesis by AR Cieslik (Jan. 2009).

**DISSERTATIONS**

-

**SCIENTIFIC PUBLICATIONS**

1. Cieslik, A.R., L.P.J. Kamp, H.J.H. Clercx & G.J.F. van Heijst - Three-dimensional structures in a shallow flow. *J. Hydro-envir. Res.* 4, 89-101 (2010).

## EXPERIMENTS ON LAGRANGIAN STATISTICS IN ROTATING TURBULENCE

### PROJECT AIM

It is the aim of this research project to develop insight in the Lagrangian statistics of rotating turbulence and the single- and pair-dispersion properties of small particles in rotating turbulence. For this purpose an existing 3D Particle Tracking Velocimetry method will be made suitable for rotating turbulence experiments.

### PROGRESS

This project has been finished with the thesis of L. Del Castello (Oct. 2010).

### DISSERTATIONS

- 1 Del Castello, L. - Table-top rotating turbulence: an experimental insight through Particle Tracking. PhD thesis, Eindhoven University of Technology, The Netherlands (2010).

### SCIENTIFIC PUBLICATIONS

-

### PROJECT LEADERS

HJH Clercx

### RESEARCH THEME

Complex dynamics of fluids

### PARTICIPANTS

L Del Castello, HJH Clercx

### COOPERATIONS

Prof C Cambon (ENS Lyon, France), Prof A Tsinober (Univ. Tel Aviv, Israel), W Kinzelbach (ETH Zürich, Switzerland), B Luethi (ETH Zürich, Switzerland)

### FUNDED

NWO-VICI	-
University	-
FOM	-
STW	-
NWO Other	100%
Industry	-
TNO	-
GTI	-
EU	-
Scholarships	-

### START OF THE PROJECT

2005

### INFORMATION

HJH Clercx

040 247 2680

[h.j.h.clercx@tue.nl](mailto:h.j.h.clercx@tue.nl)

[www.fluid.tue.nl](http://www.fluid.tue.nl)

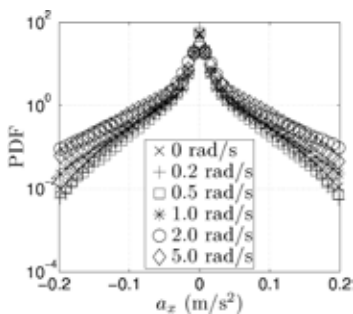

PDFs of the horizontal (left) and vertical (right) components of the acceleration for all (non-)rotating experiments. The emergence of large scale columnar flow structures is reflected in these PDFs. Rotation enhances the tails of the horizontal acceleration PDFs while those of the vertical acceleration PDFs are suppressed.

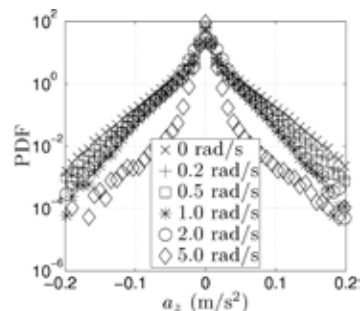

## A NEW WAY OF UNDERSTANDING CHAOTIC WIND BURSTING AT NIGHT

### PROJECT LEADERS

BJH van de Wiel, HJH Clercx,  
GJF van Heijst

### RESEARCH THEME

Complex dynamics of fluids

### PARTICIPANTS

JMM Donda, BJH van de Wiel,  
HJH Clercx, GJF van Heijst

### COOPERATIONS

Dr A Moene (WUR), Prof H Jonker  
(TUD), Dr Baas (KNMI)

### FUNDED

Vidi NWO-ALW  
University -  
FOM -  
STW -  
NWO Other 100%  
Industry -  
TNO -  
GTI -  
EU -  
Scholarships -

### START OF THE PROJECT

2006

### INFORMATION

BJH van de Wiel  
040 247 4285  
b.j.h.v.d.wiel@tue.nl  
www.fluid.tue.nl

### PROJECT AIM

The project aims to find the physical mechanism that drives intermittent (discontinuous) turbulence in the nocturnal atmospheric boundary layer. During intermittency, periods with 'laminar' flow are interrupted by chaotic bursts of turbulence and a significant transport of heat, moisture and momentum occurs. Key-tools are theoretical analysis combined with Direct Numerical Simulation techniques.

### PROGRESS

The candidate started recently (Oct. 2010). In a previous study on two phase pipe flow in a laboratory it was shown that different flow regimes (as intermittent turbulence) may occur for different forcings. Those regimes show a striking similarity with atmospheric flow regimes. The candidate started by simulating those regimes by constructing a so-called 'minimal model', which consists of two coupled non-linear differential equations with parameterized mixing physics. In future research the results will be generalized such as to improve insight in atmospheric mixing processes.

### DISSERTATIONS

-

### SCIENTIFIC PUBLICATIONS

1. Wiel, B.J.H. van de, A.F. Moene, G.J. Steeneveld, P. Baas, F.C. Bosveld & A.A.M. Holtslag - A conceptual view on inertial oscillations and nocturnal low-level jets. *J. Atmos. Sci.* 67, 2679-2689 (2010).

# EFFECTS OF ROTATION IN QUASI TWO-DIMENSIONAL TURBULENCE IN A THIN FLUID LAYER

## PROJECT AIM

The aim of the project is to gain insight in the dynamics of vortex structures in a shallow fluid layer under the influence of background rotation. The project combines laboratory experiments and numerical flow simulations..

## PROGRESS

This project has been concluded with the PhD thesis of M. Duran Matute (Nov. 2010).

## DISSERTATIONS

1. Duran Matute, M. - Dynamics of shallow flows with and without background rotation. PhD thesis, Eindhoven University of Technology, The Netherlands (2010).

## SCIENTIFIC PUBLICATIONS

1. Duran Matute, M., L.P.J. Kamp, R.R. Triefling & G.J.F. van Heijst - Scaling of shallow axisymmetric flows. J. Fluid. Mech. 648, 471-484 (2010).
2. Duran Matute, M., M, J. Albagnac, L.P.J. Kamp & G.J.F. van Heijst - Dynamics and structure of decaying shallow dipole vortices. Phys. Fluids 22, 116606 1-9 (2010).
3. Triefling R.R., G.J.F. van Heijst & Z. Kizner - Barotropic elliptical dipoles in a rotating fluid. Theor. Comp. Fluid Dyn. 24, 111-115 (2010).
4. Triefling, R.R., G.J.F. van Heijst & Z. Kizner - Laboratory experiments on multipolar vortices in a rotating fluid. Phys. Fluids 22, 094104 1-12 (2010).

## PROJECT LEADERS

GJF van Heijst

## RESEARCH THEME

Complex dynamics of fluids

## PARTICIPANTS

M Duran Matute, LPJ Kamp, RR Triefling, GJF van Heijst

## COOPERATIONS

Prof Z Kizner (Israel)

## FUNDED

CONACYT	
University	-
FOM	-
STW	-
NWO Other	-
Industry	-
TNO	-
GTI	-
EU	-
Scholarships	100%

## START OF THE PROJECT

2006

## INFORMATION

GJF van Heijst  
040 247 2722  
g.j.f.v.heijst@tue.nl  
www.fluid.tue.nl

**PROJECT LEADERS**

GJF van Heijst

**RESEARCH THEME**

Complex dynamics of fluids

**PARTICIPANTS**

F Fontenele Araujo, RR Trieling,

GJF van Heijst

**COOPERATIONS**

Prof H Nijmeijer (TU/e-Wbt)

**FUNDED**

TUE

University 100%

FOM -

STW -

NWO Other -

Industry -

TNO -

GTI -

EU -

Scholarships -

**START OF THE PROJECT**

2007

**INFORMATION**

GJF van Heijst

040 247 2722

g.j.f.v.heijst@tue.nl

www.fluid.tue.nl

**PROJECT AIM**

The aims of the project are:

- to quantify and validate the efficiency of mixing;
- to explore the controllability of the flow through external excitation.

**PROGRESS**

This project has been closed at 31 October 2009.

**DISSERTATIONS**

-

**SCIENTIFIC PUBLICATIONS**

1. Hoeijmakers, M., F. Fontenele Araujo, G.J.F. van Heijst, H. Nijmeijer & R.R. Trieling - Control of mixing via entropy tracking. Phys. Rev. E 81, 066302 1-7 (2010).

**PROJECT AIM**

It is the aim of these research projects to develop a better insight in the spectral and transport properties of quasi-two-dimensional flows, the dynamics of vortices in rotating and stratified fluids, and the effects of domain boundaries (solid walls) on (quasi-)2D turbulence.

**PROGRESS**

This project has been finished with the thesis by G.H. Keetels (June 2008).

**DISSERTATIONS**

-

**SCIENTIFIC PUBLICATIONS**

1. Keetels, G.H., H.J.H. Clercx & G.J.F. van Heijst - On the origin of spin-up processes in decaying two-dimensional turbulence. *Eur. J. Mech. B/Fluids* 29, 1-8 (2010).
2. Shivamoggi, B.K., G.J.F. van Heijst & J.J. Rasmussen - Divorticity and dihelicity in two-dimensional hydrodynamics. *Phys. Lett. A* 374, 2309-2311 (2010).

**PROJECTLEADERS**

HJH Clercx, GJF van Heijst

**RESEARCHTHEME**

Complex dynamics of fluids

**PARTICIPANTS**

GH Keetels, W Kramer, GJF van Heijst, HJH Clercx

**COOPERATIONS**

K Schneider (Univ. Marseille, France), Prof CH Bruneau (Univ. of Bordeaux, France), Prof BK Shivamoggi (UCL, Orlando, USA), Prof JJ Rasmussen (DTU-Risoe, Denmark).

**FUNDED**

FOM	-
University	-
FOM	100%
STW	-
NWO Other	-
Industry	-
TNO	-
GTI	-
EU	-
Scholarships	-

**START OF THE PROJECT**

2003

**INFORMATION**

HJH Clercx, 040-247 2680

[h.j.h.clercx@tue.nl](mailto:h.j.h.clercx@tue.nl)

[www.fluid.tue.nl](http://www.fluid.tue.nl)

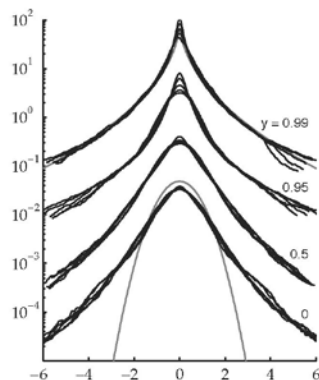
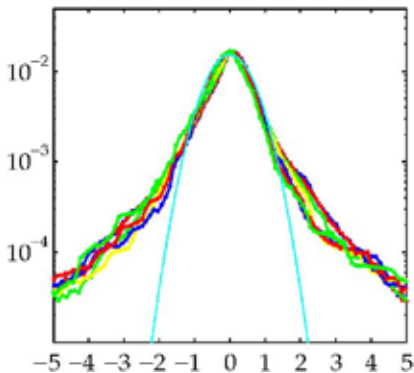

Probability density functions for forced 2D turbulence in bounded domains. Left: bounded square domain; right: periodic channel domain. A Gaussian distribution is given for comparison. The interior flow is in both cases characterized by similar PDFs: Gaussian core and exponential tails. Close to the no-slip walls the probability of observing very weak and very strong vorticity increments is increased at the expense of fluctuations at average intensity.

**PROJECT LEADERS**

HJH Clercx

**RESEARCH THEME**

Complex dynamics of fluids

**PARTICIPANTS**

E Aparicio Medrano, W Kramer, BJH van de Wiel, HJH Clercx

**COOPERATIONS**

Prof V Armenio (Univ Triest, Italy)  
 Prof E Meiburg (UCSB, USA), Dr KB Winters (Scripps, USA), Dr RE Uittenbogaard (Deltares), Prof M Scheffer (WUR)

**FUNDED**

NWO-VICI, Deltares  
 University -  
 FOM -  
 STW -  
 NWO Other 50%  
 Industry -  
 TNO -  
 GTI 50%  
 EU -  
 Scholarships -

**START OF THE PROJECT**

2006

**INFORMATION**

HJH Clercx  
 040 247 2680  
 h.j.h.clercx@tue.nl  
 www.fluid.tue.nl

**PROJECT AIM**

The aim of this project is twofold. In a first step the effects of rotating and or buoyancy on oscillating/pulsating channel flow subject to wind stress at the free surface will be studied. The second objective concerns the quantification of the vertical turbulent transport of phytoplankton by DNS and the associated process of scum formation at the free surface. This part concerns a combined study involving numerical simulations (TU/e), field observations (Deltares) and laboratory experiments (WUR).

**PROGRESS**

The oscillating stratified (by surface heating) turbulent channel flow subjected to a wind stress is investigated by means of Direct Numerical Simulations and Large Eddy Simulations. This model serves as a simplified description of a fluid column in a tidal driven estuary. The generation of turbulence near the bottom wall and the free surface has been investigated and the vertical transport and mixing has been studied. The density stratification suppresses vertical fluctuations and, hence, limits the influence of the wind stress to the upper fluid layers. In a separate study the vertical transport of phytoplankton in weak turbulence with and without stratification is considered. As a first step field studies have been conducted to obtain data on the physical and biological properties of a typical lake. DNS of the vertical transport of phytoplankton in homogeneous isotropic turbulence are in progress.

**DISSERTATIONS**

-

**SCIENTIFIC PUBLICATIONS**

1. Kramer, W., H.J.H. Clercx & V. Armenio - Turbulent oscillating channel flow subjected to a free-surface stress. *Phys. Fluids* 22, 090510 1-12 (2010).
2. Kramer, W., V. Armenio & H.J.H. Clercx - Turbulent oscillating channel flow subjected to wind stress. In: *Direct and Large-Eddy Simulation VII*, eds. V. Armenio, B.J. Geurts, and J. Frohlich, Springer Netherlands, pp. 25-31 (2010).

Buoyancy regulation of microcystis. Due to photosynthesis the cells become heavier (formation of carbohydrates) and without light they become lighter due to respiration.

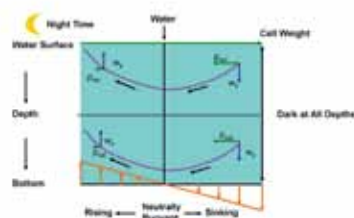
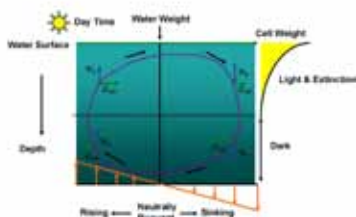

### PROJECT AIM

Large scale coherent flows play an important role in both geophysical fluid as well in fusion, since they interact with the turbulence and can give rise to transport barriers. It turns out that these phenomena in fluids and plasma can be described by the same equation. Therefore a relatively simple fluid dynamics experiment is proposed, with the aim to study how zonal flows affect turbulence and turbulent transport and how these flows are sustained in the improved confinement mode. Comparisons fluid–plasmas by experiments and numerical simulations are an integral part of this research. In this project visualisation of the effect of flow on turbulence is a key element, whereas the fluid dynamics experiment will also serve as a test bed for control methods (link with project “Control of plasma transport by plasma flow” which is being conducted at Dept. Mech. Engineering (TU/e).

### PROGRESS

This project started in November 2010. Literature study has been conducted on basic fusion phenomena, turbulent transport in MHD and 2D flows, and laboratory experiments in shallow fluids. Numerical simulations of magnetically driven liquid metal (alloy; fluent at room temperature), aimed at exploration of the relevant parameter space for turbulence experiments in shallow fluid layers (COMSOL), are currently being conducted. Three different geometries (semi-infinite domain, duct and annular geometry) are being considered with emphasis on boundary layer dynamics and generation of 3D recirculating flows.

### DISSERTATIONS

-

### SCIENTIFIC PUBLICATIONS

-

### PROJECTLEADERS

HJH Clercx, GJF van Heijst

### RESEARCHTHEME

Complex dynamics of fluids

### PARTICIPANTS

VH Fernandes, LPJ Kamp, GJF van Heijst, HJH Clercx

### COOPERATIONS

Prof N Lopes Cardozo (TU/e-TN), Dr R Jaspers (TU/e-TN), Prof M Steinbuch (TU/e-Wbt), Prof M de Baar (FOM-Nieuwegein; TU/e-Wbt).

### FUNDED

TUE	
University	100%
FOM	-
STW	-
NWO Other	-
Industry	-
TNO	-
GTI	-
EU	-
Scholarships	-

### START OF THE PROJECT

2010

### INFORMATION

HJH Clercx  
040 247 2680  
h.j.h.clercx@tue.nl

GJF van Heijst  
040 247 2722  
g.j.f.v.heijst@tue.nl  
www.fluid.tue.nl



## UNRAVELLING 3D MIXING NEAR THE SURFACE OF ACTUATED BEADS

### PROJECT LEADERS

HJH Clercx

### RESEARCH THEME

Complex dynamics of fluids

### PARTICIPANTS

NR Moharana, RR Trieling, GJF van Heijst, HJH Clercx

### COOPERATIONS

Prof M Prins (TU/e-TN; Philips), Dr

AM de Jong (TU/e-TN),

Prof J den Toonder (TU/e-Wbt;

Philips), Dr MFM Speetjens (TU/e-Wbt).

### FUNDED

STW

University -

FOM -

STW 100%

NWO Other -

Industry -

TNO -

GTI -

EU -

Scholarships -

### START OF THE PROJECT

2010

### INFORMATION

HJH Clercx

040 247 2680

[h.j.h.clercx@tue.nl](mailto:h.j.h.clercx@tue.nl)

[www.fluid.tue.nl](http://www.fluid.tue.nl)

### PROJECT AIM

This project started in March 2010 and is part of a larger research programme on magneto-active mixing and catching by small beads for microfluidic biosensor applications. It concerns the full exploitation of the scavenging properties of magnetic beads in microfluidic devices, control of fluid mixing, and the enhancement of the capture of (biological) targets by the beads. Key in this process is knowledge of the unsteady streamline pattern around a moving and rotating sphere and a detailed understanding of the local mixing properties nearby the sphere surface. Quantitative information, obtained from a laboratory experiment (on macroscopic scale), combined with numerical modelling will be used to optimize the mixing and capturing processes. Actuation protocols will be devised to enhance the capture probability of target particles by the bead.

### PROGRESS

The regime of suitable actuation protocols for a rigid sphere in a viscous fluid is currently being explored. This includes symmetry analysis of generic forcing protocols (to uncover periodic lines that play a central role in characterizing the mixing properties in the flow), numerical analysis of the chaotic streamline pattern, and simulation of the dispersion of small (passive) target particles for selected actuation protocols of the rigid sphere. An experiment aimed at quantifying mixing is currently being designed.

### DISSERTATIONS

-

### SCIENTIFIC PUBLICATIONS

-

# DYNAMIC BEHAVIOUR OF A HIGH-ALTITUDE LONG-ENDURANCE (HALE) WING

## PROJECT AIM

A new design High-Altitude Long-Endurance wing is currently under development in the EU project Vortexcell2050. For several reasons (structural and fuel load) it is desirable to have relatively thick wings. However, thick wings promote flow separation and/or massive vortex shedding, reducing flight performance significantly. The new design airfoil will be equipped with a cavity "vortex cell" in the wing in order to prevent flow separation. In this cavity a vortex will be trapped with active flow control. The goal of the current PhD project is to gain insight in the dynamic behavior of such a wing with a cavity and to explore which numerical CFD methods are suitable for estimating the unsteady forces on such an airfoil.

## PROGRESS

This project has been finished with the thesis of W.F.J. Olsman (May 2010).

## DISSERTATIONS

1. Olsman, W.F.J. - Influence of a cavity on the dynamical behaviour of an airfoil. PhD thesis, Eindhoven University of Technology, The Netherlands (2010).

## SCIENTIFIC PUBLICATIONS

1. Olsman, W.F.J., J.H. Willems, S.J. Hulshoff, A. Hirschberg & R.R. Trieling - Acoustic forcing to simulate the plunging motion of an airfoil. *J. Sound and Vibration* 329, 3679-3690 (2010).
2. Olsman, W.F.J., A. Hirschberg & R.R. Trieling - High frequency measurements on airfoils with cavities. In: *Proceedings of the 16th AIAA/CEAS Aerocoustics Conference*, 7-9 June 2010, Stockholm, Sweden. (May 2010).

## PROJECTLEADERS

GJF van Heijst

## RESEARCHTHEME

Complex dynamics of fluids

## PARTICIPANTS

WFJ Olsman, RR Trieling, GJF van Heijst

## COOPERATIONS

Prof A Hirschberg (TU/e-TN), Dr SH Hulshoff (TUD), Dr R Savelsberg (Univ of Southampton, UK).

## FUNDED

EU	
University	-
FOM	-
STW	-
NWO Other	-
Industry	-
TNO	-
GTI	-
EU	100%
Scholarships	-

## START OF THE PROJECT

2006

## INFORMATION

GJF van Heijst  
040 247 2722  
g.j.f.v.heijst@tue.nl  
www.fluid.tue.nl

**PROJECT LEADERS**

HJH Clercx

**RESEARCH THEME**

Complex dynamics of fluids

**PARTICIPANTS**

J Znaeni, RR Trieling, GJF van Heijst, HJH Clercx

**COOPERATIONS**

Dr MFM Speetjens (TU/e-Wbt), Prof VV Meleshko (Kiev National Taras Shevchenko University, Ukraine), Prof W Kinzelbach (ETH Zürich, Switzerland)

**FUNDED**

FOM	
University	-
FOM	100%
STW	-
NWO Other	-
Industry	-
TNO	-
GTI	-
EU	-
Scholarships	-

**START OF THE PROJECT**

2007

**INFORMATION**

HJH Clercx  
040 247 2680  
h.j.h.clercx@tue.nl  
www.fluid.tue.nl

**PROJECT AIM**

Mass transport in laminar flows depends essentially on the topology of the Lagrangian fluid paths. Of great practical relevance are the fundamental mechanisms that cause such fluid paths to become chaotic; this implies efficient mass transport and is the desired state in typical laminar transport processes. Aim of the project is investigation of such fundamental "chaotization" mechanisms. The project specifically concentrates on the "chaotization" of the Lagrangian fluid paths of 3D Stokes flows by nonlinear perturbation via fluid inertia. This is investigated by theoretical, numerical and experimental methods.

**PROGRESS**

Long term 3D particle tracking experiments (3D PTV) have been performed to have access to the Lagrangian fluid paths. Coherent structures are present in the flow and play an important role in the mixing process by geometrically determining the tracers transport. These measurements are currently being compared to data from numerical simulation. A new experimental setup was designed and built. It is devoted to explore a bigger range of forcing than the current setup. Experiments are in progress.

**DISSERTATIONS**

-

**SCIENTIFIC PUBLICATIONS**

1. Pouransari, Z., M.F.M. Speetjens & H.J.H. Clercx - Formation of coherent structures in three-dimensional laminar mixing flows. *J. Fluid Mech.* 654, 5-34 (2010).

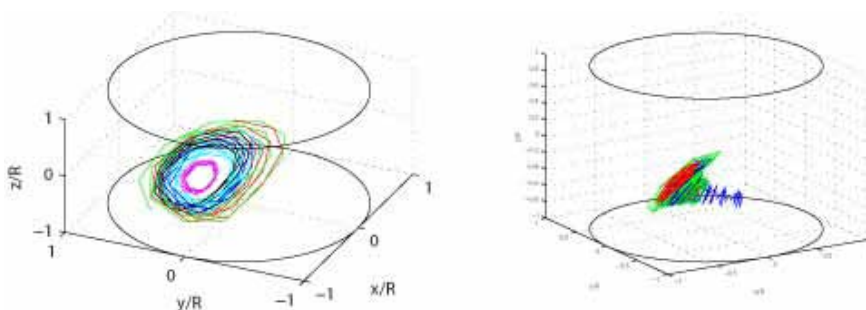

Coherent structures in the Poincaré map: elliptical islands (left) and funnels (right) after 500 forcing iterations

**PROJECT AIM**

The detailed interaction between sand and wind determines the shape of dunes that walk unaltered through deserts (so-called barchan dunes). This project aims to understand this elementary interaction in a setup where gravity is modulated using a vertically oscillated sand bed (see Fig. 1).

**PROGRESS**

In the final phase of this project we have concentrated on the relative importance of the basic aeolian transport mechanisms: saltation and creep. Creep refers to grains crawling over the surface, after being dislodged by grains that jump in the turbulent boundary layer over the sand heap (saltation)

Sand creep was measured using a variant of Particle Image Velocimetry. The creep velocities are small, and it appears the dune erosion is carried by a dense granular layer that moves in the wind, suspended just above the crest of the dune.

**DISSERTATIONS**

-

**SCIENTIFIC PUBLICATIONS**

-

Experimental setup in which the dynamics of small barchan dunes are studied in a turbulent boundary layer. The length scale of these dunes is dramatically reduced by modulating gravity.

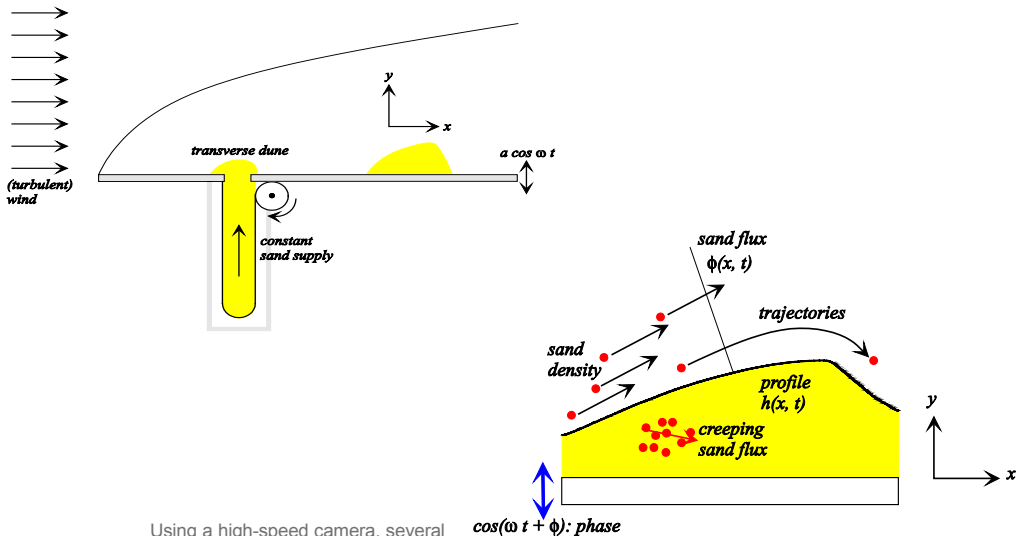

Using a high-speed camera, several quantities related to sand transport by wind can be measured.

**PROJECT LEADERS**

W van de Water, GJF van Heijst

**RESEARCH THEME**

Complex structures of fluids

**PARTICIPANTS**

D Snouck, GJF van Heijst, W van de Water

**COOPERATIONS**

Yang Zhang (Xi'an Jiaotong University, Shaanxi Province, China)

**FUNDED**

FOM	
University	-
FOM	100%
STW	-
NWO Other	-
Industry	-
TNO	-
GTI	-
EU	-
Scholarships	-

**START OF THE PROJECT**

2005

**INFORMATION**

W van de Water

040 247 3443

w.v.d.water@tue.nl

www.fluid.tue.nl

**PROJECT LEADERS**

HJH Clercx

**RESEARCH THEME**

Complex dynamics of fluids

**PARTICIPANTS**

RJAM Stevens, V Lavezzo, BJ Geurts, GJF van Heijst, HJH Clercx

**COOPERATIONS**

Prof F Toschi (TU/e-TN), Prof R Verzicco (Univ. Bari, Italy), Prof D Lohse (Univ. Twente), Prof G Ahlers (UCSB, USA), Dr EMJ Komen (NRG-ECB), Dr RPJ Kunnen (RWTH, Germany).

**FUNDED**

FOM	
University	-
FOM	100%
STW	-
NWO Other	-
Industry	-
TNO	-
GTI	-
EU	-
Scholarships	-

**START OF THE PROJECT**

2008

**INFORMATION**

HJH Clercx  
 040 247 2680  
 h.j.h.clercx@tue.nl  
 www.fluid.tue.nl

Instantaneous fluid temperature isocontours at Rayleigh number  $Ra=2 \cdot 10^7$

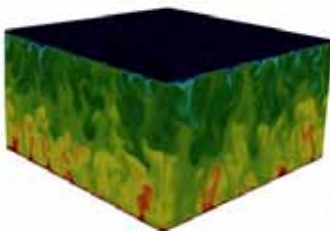

**PROJECT AIM**

The aim of this research project is threefold: 1) understanding of the effect of background rotation on Rayleigh-Bénard convection (RBC) and the role of Ekman boundary layers on the emergence of coherent structures in the flow, 2) heat transport measurements in (rotating) RBC in cylindrical convection cells, and 3) analysis of the dispersion of particles with (thermal) inertia and its subsequent feedback on the flow. For this purpose both laboratory experiments (SPIV measurements of the flow in a cylindrical convection cell) and direct numerical simulations have been performed (both cylindrical geometry and channel geometry).

**PROGRESS**

Currently, Nusselt measurements have been conducted for rotating RBC in cylinders with diameter over height aspect ratios equal to one, four-third and two. The currently available numerical codes for computation of turbulent RBC between two parallel plates have been restructured for HPC applications. The dynamics of particles with (thermal) inertia has been included and tested and large-scale numerical simulations are being conducted (within the DCCP programme of NWO-NCF).

**DISSERTATIONS**

-

**SCIENTIFIC PUBLICATIONS**

1. Kunnen, R.P.J., H.J.H. Clercx & B.J. Geurts - Vortex statistics in turbulent rotating convection. *Phys. Rev. E* 82, 036306 1-12 (2010).
2. Kunnen, R.P.J., B.J. Geurts & H.J.H. Clercx – Experimental and numerical investigation of turbulent convection in a rotating cylinder. *J. Fluid Mech.* 642, 445-476 (2010).
3. Lavezzo, V., A. Soldati, S. Geraschenko, Z. Warhaft, and L. R. Collins - On the role of gravity and shear on inertial particle accelerations in near-wall turbulence. *J. Fluid Mech.* 658, 229-246 (2010).
4. Stevens, R.J.A.M., H.J.H. Clercx & D. Lohse - Optimal Prandtl number for heat transfer in rotating Rayleigh-Bénard convection. *New J. Phys.* 12, 075005, 1-8 (2010).
5. Stevens, R.J.A.M., H.J.H. Clercx & D. Lohse - Boundary layers in rotating weakly turbulent Rayleigh-Bénard convection. *Phys. Fluids* 22, 085103 1-13 (2010).
6. Stevens, R.J.A.M., H.J.H. Clercx, and D. Lohse - Warmtetransport in een roterende turbulente stroming. *Ned. Tijdschrift voor Nat.* 76, 54-57 (2010).
7. Weiss, S. R.J.A.M. Stevens, J.-Q. Zhong, H.J.H. Clercx, D. Lohse & G. Ahlers - Finite-size effects lead to supercritical bifurcations in turbulent rotating Rayleigh-Benard convection. *Phys. Rev. Lett.* 105, 224501 1-4 (2010).



Instantaneous snapshot of particle positions. Particles are coloured with their temperature: red hot/high temperature and in blue cold/low temperature (the color scale is based on particle initial temperature).

**PROJECT AIM**

It is the aim of this project to reach a better understanding of stress distributions in static granular material, the dynamics of moving (excited) granular mixtures, the dynamical behaviour of particles in plasmas and the mixing behaviour of 3D viscous flows.

**PROGRESS**

In direct collaboration with Prof.dr. S.A. Trigger (Moscow) research has been carried out on a number of different aspects of granular systems. The related work on dusty plasmas has also resulted in a few publications.

**DISSERTATIONS**

-

**SCIENTIFIC PUBLICATIONS**

1. Bobrov, V.B., S.A. Trigger & G.J.F. van Heijst - Exact relation in the density functional theory. Europhys. Lett. 92, 57001 1-4 (2010).
2. Bobrov, V.B., S.A. Trigger, G.J.F. van Heijst & P.P.J.M. Schram - Kramers-Kronig relations for the dielectric function and the static conductivity of Coulomb systems. Europhys. Lett. 90, 10003 1-4 (2010).
3. Bobrov, V.B., S.A. Trigger, G.J.F. van Heijst & P.P.J.M. Schram - Virial theorem for an inhomogeneous medium, boundary conditions for the wave functions, and stress tensor in quantum statistics. Phys. Rev. E 82, 010102 1-3 (2010).
4. Dubinova, D.D., P.P.J.M. Schram & J. van Dijk – Dust particle current in the presence of an external electric field. J. Phys. A 43, 365501 1-10 (2010).
5. Trigger, S.A., W. Ebeling, G.J.F. van Heijst, P.P.J.M. Schram & M. Sokolov - On anomalous diffusion in a plasma in velocity space. Phys. Plasmas 17, 042102 1-8 (2010).

**PROJECTLEADERS**

GJF van Heijst

**RESEARCHTHEME**

Complex structures of fluids

**PARTICIPANTS**

GJF van Heijst, PPJM Schram

**COOPERATIONS**

Prof SI Trigger (Moscow, Russia)

**FUNDED**

NWO	
University	-
FOM	-
STW	-
NWO Other	100%
Industry	-
TNO	-
GTI	-
EU	-
Scholarships	-

**START OF THE PROJECT**

2000

**INFORMATION**

GJF van Heijst  
 040 247 2722  
[g.j.f.v.heijst@tue.nl](mailto:g.j.f.v.heijst@tue.nl)  
[www.fluid.tue.nl](http://www.fluid.tue.nl)

## ATTRIBUTING THE SOURCES OF TROPOSPHERIC OZONE FROM SPACE: CONSTRAINING BIOGENIC VOC EMISSIONS AND EMISSIONS FROM BIOMASS BURNING.

### PROJECT LEADERS

KF Boersma, PF Levelt, GJF van Heijst

### RESEARCH THEME

Complex dynamics of fluids

### PARTICIPANTS

MHA van Geel, GCM Vinken, WW Verstraeten, KF Boersma

### COOPERATIONS

KNMI, BIRA, Harvard-Smithsonian

### FUNDED

NWO-VIDI	
University	-
FOM	-
STW	-
NWO Other	100%
Industry	-
TNO	-
GTI	-
EU	-
Scholarships	-

### START OF THE PROJECT

2010

### INFORMATION

KF Boersma  
040 247 2160  
k.f.boersma@tue.nl  
www.fluid.tue.nl  
www.knmi.nl/~boersma

### PROJECT AIM

Ozone is produced in the troposphere by photochemical oxidation of volatile organic compounds (VOCs) and CO in the presence of nitrogen oxides. These precursors have large and changing anthropogenic sources and some natural sources may be perturbed by climate change. In this project, we will use satellite data as top-down constraints on emissions of isoprene, and derive emissions of HCHO and NO<sub>x</sub> from biomass burning. We focus on 3 tasks, the first two focused on biogenic emissions, the third on biomass burning. We will first evaluate isoprene chemistry in TM5. We then proceed and apply satellite observations of HCHO columns from the GOME(-2), SCIAMACHY, and OMI instruments to better estimate isoprene emissions from biogenic sources and fires.

### PROGRESS

The Ph.D.-candidate started working on this project on 01-11-2010. In her first two months on the project she has been successfully setting up the chemistry-transport model (TM5) at our computing system at the TU/e. She also started the analysis of GOME-2 retrievals of HCHO columns.

### DISSERTATIONS

-

### SCIENTIFIC PUBLICATIONS

1. Veefkind, J. P., K. F. Boersma, J. Wang, T. Kurosu, N. Krotkov & P. F. Levelt - Global Analysis of the Relation between Aerosols and Short-lived Trace Gases. *Atmos. Chem. Phys. Discuss.* 10, 18919-18951 (2010).
2. Huijnen, V., J. E. Williams, M. van Weele, T. P. C. van Noije, M. Krol et al. - The global chemistry transport model TM5: description and evaluation of the tropospheric chemistry version 3.0. *Geosci. Model Dev.* 3, 445-473 (2010).

# ATTRIBUTING THE SOURCES OF TROPOSPHERIC OZONE FROM SPACE: MAPPING NO<sub>2</sub> EMISSIONS WITH SATELLITE OBSERVATIONS

## PROJECT AIM

Ozone is produced in the troposphere by photochemical oxidation of volatile organic compounds (VOCs) and CO in the presence of nitrogen oxides. These precursors have large and changing anthropogenic sources and some natural sources may be perturbed by climate change. In this project, we will exploit NO<sub>2</sub> column data from SCIAMACHY, OMI, and GOME(-2) as top-down constraints on emissions of NO<sub>x</sub>, building on earlier work with GOME and OMI. We will first improve the description of a number of physical and chemical processes relevant to NO<sub>x</sub> emissions in the global models we will use (TM5, GEOS-Chem). We then apply satellite observations of NO<sub>2</sub> columns from the GOME(-2), SCIAMACHY, and OMI instruments to better estimate NO<sub>x</sub> emissions from different categories, including international shipping, lightning, biomass burning, and anthropogenic emissions.

## PROGRESS

The Ph.D-candidate started working on this project on 01-10-2010. In his first two months on the project he has been successfully setting up the computing infrastructure, and the chemistry-transport model (GEOS-Chem) at our computing system at the TU/e. He also implemented a parameterization to better describe non-linear chemistry within shipping plumes in the GEOS-Chem model.

## DISSERTATIONS

-

## SCIENTIFIC PUBLICATIONS

1. Zhou, Y., D. Brunner, R. J. D. Spurr, K. F. Boersma, M. Sneep, C. Popp & B. Buchmann - Accounting for surface reflectance anisotropy in satellite retrievals of tropospheric NO<sub>2</sub>. *Atmos. Meas. Tech.* 3, 1185-1203 (2010).
2. Huijnen, V., H. J. Eskes, B. Amstrup, R. Bergstrom, K. F. Boersma et al. - Comparison of OMI NO<sub>2</sub> tropospheric columns with an ensemble of global and European regional air quality models. *Atmos. Chem. Phys.* 10, 3273-3296 (2010).
3. Yoshida, Y., B. N. Duncan, C. Retscher, K. E. Pickering, E. A. Celarier, J. Joiner, K. F. Boersma & J. P. Veefkind - The impact of the 2005 Gulf hurricanes on pollution emissions as inferred from Ozone Monitoring Instrument (OMI) nitrogen dioxide. *Atmos. Env.* 44, 1443-1448 (2010).
4. Hains, J., K. F. Boersma, M. Kroon, R. J. Dirksen, H. Volten et al. - Testing and Improving OMI DOMINO Tropospheric NO<sub>2</sub> Using Observations from the DANDELIONS and INTEX-B Validation Campaigns. *J. Geophys. Res.* 115, D05301 (2010).
5. Lamsal, L. N., R. V. Martin, A. van Donkelaar, E. A. Celarier, E. J. Bucela, K. F. Boersma, R. Dirksen, C. Luo & Y. Wang - Indirect Validation of Tropospheric Nitrogen Dioxide Retrieved from the OMI Satellite Instrument: Insight into the Seasonal Variation of Nitrogen Oxides at Northern Midlatitudes. *J. Geophys. Res.* 115, D05302 (2010).
6. Lin, J. T., M. McElroy & K. F. Boersma - Constraint of Anthropogenic NO<sub>x</sub> Emissions in China from Different Sectors: A New Methodology Using Multiple Satellite Retrievals. *Atmos. Chem. Phys.* 10, 63-78 (2010).

## PROJECT LEADERS

KF Boersma, PF Levelt, GJF van Heijst

## RESEARCH THEME

Complex dynamics of fluids

## PARTICIPANTS

GCM Vinken, MHA van Geel, WW Verstraeten, KF Boersma

## COOPERATIONS

KNMI, Harvard University

## FUNDED

NWO-VIDI	
University	-
FOM	-
STW	-
NWO Other	100%
Industry	-
TNO	-
GTI	-
EU	-
Scholarships	-

## START OF THE PROJECT

2010

## INFORMATION

KF Boersma  
040 247 2160  
k.f.boersma@tue.nl  
www.fluid.tue.nl  
www.knmi.nl/~boersma



# VALIDATION OF TROPOSPHERIC TRACE GAS RETRIEVAL (FOCUS ON NITROGEN DIOXIDE) BY SATELLITES WITH GROUND BASED MEASUREMENTS

## PROJECT LEADERS

HM Kelder, PF Levelt, GJF van Heijst

## RESEARCH THEME

Complex dynamics of fluids

## PARTICIPANTS

T Vlemmix, AJM Piters, HM Kelder, PF Levelt

## COOPERATIONS

KNMI

## FUNDED

SRON	
University	100%
FOM	-
STW	-
NWO Other	-
Industry	-
TNO	-
GTI	-
EU	-
Scholarships	-

## START OF THE PROJECT

2007

## INFORMATION

PF Levelt  
levelt@knmi.nl  
www.fluid.tue.nl

## PROJECT AIM

Ground-based NO<sub>2</sub> observations for satellite validation. The aim of the project is to retrieve tropospheric nitrogen dioxide (NO<sub>2</sub>) concentrations from high resolution spectral observations of scattered sunlight. This NO<sub>2</sub> product is used to validate retrievals from the OMI and SCIAMACHY satellite instruments.

## PROGRESS

In 2010 the MAX-DOAS retrieval algorithm was further developed in order to infer the vertical distribution of NO<sub>2</sub> within the troposphere, which is especially relevant for validation of satellite derived tropospheric NO<sub>2</sub> columns. Radiative transfer simulations have been performed to investigate the potential of ground based MAX-DOAS observations to discriminate between NO<sub>2</sub> layers at different altitudes in the troposphere. The simulations have shown that MAX-DOAS measurements are sensitive to NO<sub>2</sub> between 0 and 10 km altitude, although the sensitivity decreases with altitude. Based on these conclusions a retrieval algorithm was developed with 3 selected free parameters for the NO<sub>2</sub> retrieval. This retrieval algorithm has been tested in various ways and was applied to observations performed during the CINDI campaign (Cabauw, The Netherlands, 2009). A reasonable agreement was found with both LIDAR tropospheric NO<sub>2</sub> column observations and in-situ observations of NO<sub>2</sub> surface concentrations (see figures). The results will be published in AMTD, spring 2011.

## DISSERTATIONS

-

## SCIENTIFIC PUBLICATIONS

- Vlemmix, T., A.J.M. Piters, P. Stammes, P. Wang & P.F. Levelt - Retrieval of tropospheric NO<sub>2</sub> using the MAX-DOAS method combined with relative intensity measurements for aerosol correction. Atmos. Meas. Tech. Discuss. 3, 1-50 (2010).
- Roscoe, H. K., M. Van Roozendaal, C. Fayt, A. du Piesanie, N. Abuhassan, T. Vlemmix et al. - Intercomparison of slant column measurements of NO<sub>2</sub> and O<sub>4</sub> by MAX-DOAS and zenith-sky UV and visible spectrometers. Atmos. Meas. Tech. 3, 1629-1646 (2010).

Comparison of partial tropospheric NO<sub>2</sub> columns measured by a LIDAR (RIVM) and MAX-DOAS (KNMI) during the CINDI campaign 2009

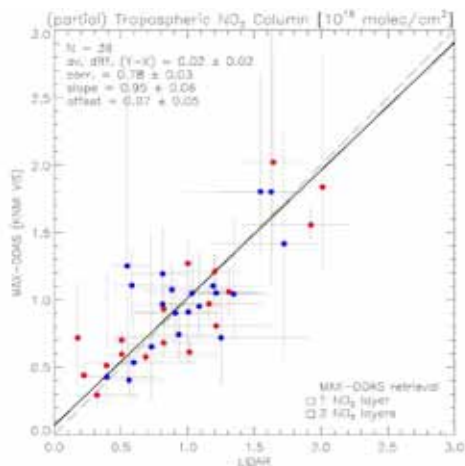





Prof.dr. LPH de Goey

The goal of the research programme of the 'Combustion Technology Group' is to gain insight in and knowledge on reacting flows in order to develop new and improve existing models of combustion systems. The models are used to guide new developments in the struggle to come to more efficient and clean conversion systems of fossil and sustainable fuels for a sustainable society. The knowledge and models developed are based on thorough physical and chemical understanding of the processes. This means that the gap between fundament and application has to be bridged continuously by transforming models describing physical/chemical behaviour on the smallest scales to models for the macroscopic scale of the full system. The knowledge is based on 'generic' theoretical and numerical insights for the propagation and structure of idealised flames and their interaction with acoustic waves, turbulent structures and inert/reacting surfaces. Most models for the combustion chemistry are based on a combination of the so-called laminar flamelet concept and chemical reduction methods leading to new techniques like FGM.

There is also a close entanglement of theoretical/numerical and experimental research. Available diagnostic techniques are e.g. flame visualisation, absorption techniques, LDV, PIV, LIF and Rayleigh scattering. Validation with the available laser-diagnostic measurement systems in the laboratory and real applications is carried out to disentangle the processes taking place on the various length and time scales. These measurements are carried out in flat (non-)adiabatic flames stabilised on the Heat Flux burner, laminar flames on Bunsen-type burners, flat turbulent flames on a weak-swirl burner, biomass grid, tube and bed reactors, optically-accessible combustion vessels and optically-accessible engines. Application areas are: small-scale laminar combustion systems, combustion of bio-fuels, engines and gas turbines. The application area of combustion engines is of particular interest.

# STRETCH EFFECTS ON HYDROGEN/METHANE/AIR LAMINAR FLAME PROPAGATION AND EXTINCTION (STRELA)

## PROJECT AIM

The main scientific objective of the proposed research is to establish mechanisms through which flame stretch affects propagation and extinction of lean (limit) single-front methane/hydrogen/air flames. To meet this objective, it is proposed to carry out a detailed experimental investigation of upward propagation and extinction of lean/limit flames in vertical cylindrical channels of different diameters, closed at the upper end and opened at the bottom end.

## PROGRESS

Ultra-lean hydrogen-methane air flames in a standard flammability tube have been studied experimentally. A transition from the flame-cap regime, observed near flammability limits, to the rising-bubble-like flames at increased fuel gas concentrations was observed and experimentally studied. Flames gas-dynamic structure was examined using the Particle Image Velocymetry Method and their temperature fields measured by the Thin Filament Pyropepy method. It was found that flame caps reside on the top of a moving upward mass of hot gas, which has the shape of a rising hot bubble. A local counter-flow gas dynamic pattern is formed at the top part of such bubble, and the flame cup surface is located along the stagnation surface. A weak secondary cone-like flame is observed below the main flame front of a flame cup. The transition to the bubble-like flame occurs without sudden changes of the flame shape, but with an abrupt increase, of the heat release rate in the flame front and abrupt changes in the combustion products flow pattern.

## DISSERTATIONS

-

## SCIENTIFIC PUBLICATIONS

1. Y. Shoshin, J.A. van Oijen, A. Sepman, L.P.H. de Goeij, Experimental and computational study of the transition to the flame ball regime at normal gravity, Proc. Combust. Inst., 33, in press, 2010.
2. Y. Shoshin, L.P.H. de Goeij, Experimental study of lean flammability limits of methane/hydrogen/air mixtures in tubes of different diameters, Experimental Thermal and Fluid Science 34 (2010) 373–380.
3. Y.L. Shoshin, J.A. van Oijen, L.B.W. Peerlings, B.J.C. van Bakel, L.P.H. de Goeij, Measured and simulated temperature fields of ultra-lean flames propagating in hydrogen- methane-airmixtures in a half opened vertical tube, in Proceedings of SPEIC10 - Towards Sustainable Combustion - Tenerife, Spain 16-18 June, 2010.

## PROJECT LEADERS

LPH de Goeij

## RESEARCH THEME

Complex structures of fluids

## PARTICIPANTS

Y Shoshin, J van Oijen

## COOPERATIONS

-

## FUNDED

European Commission, FP7 Marie

Curie Program, IIF

University -

FOM -

STW -

NWO Other -

Industry -

TNO -

GTI -

EU 100%

Scholarships -

## START OF THE PROJECT

2008

## INFORMATION

Y Shoshin

040 247 5689

Y.S.Shoshin@tue.nl

## STUDY OF ELECTRIC FIELD INFLUENCE ON LAMINAR PREMIXED FLAMES

### PROJECT LEADERS

LPH de Goey

### RESEARCH THEME

Complex structures of fluids

### PARTICIPANTS

EN Volkov, VN Kornilov

### COOPERATIONS

-

### FUNDED

AETHER (EU)

University -

FOM -

STW -

NWO Other -

Industry -

TNO -

GTI -

EU 100%

Scholarships -

### START OF THE PROJECT

2008

### INFORMATION

EN Volkov

040 247 5689

E.Volkov@tue.nl

### PROJECT AIM

The aim of the project is to study the mechanism of influence of an electric field on laminar Premixed CH<sub>4</sub>/air flame and to improve our understanding of this complex phenomenon. Main emphasis will be placed on assessment of the applicability of electric fields (both constant and alternating) for damping thermoacoustic instabilities in the case of burner stabilized, laminar flames.

### PROGRESS

The influence of a DC EF on the thermoacoustic behavior of a laminar CH<sub>4</sub>/air flames is studied. The obtained results show that the DC EF can be used to modify the thermoacoustic transfer function (TF) of multiple Bunsen-type flames. The application of the EF leads to better stabilization of the flames. In contrast to flat flames the change in TF can be achieved without secondary ionization. The magnitude of the EF influence, however, depends on the flame anchoring. The maximal effect is observed for lifted flames. The main effect of the EF on the flame TF can be characterized as a change in the phase slope, which is equivalent to a change in the TF time delay. The most plausible mechanism of this modification is a change in the convective time delay due to the better flame anchoring.

### DISSERTATIONS

-

### SCIENTIFIC PUBLICATIONS

1. E.N. Volkov, V.N. Kornilov and L.P.H. de Goey, "Influence of DC Electric Field on Thermo-Acoustic Transfer Function of Multiple Bunsen-Type Flames," Proceedings of 17th International Congress on Sound and Vibration, Cairo, Egypt, 18-22 July, 2010, Article 660, pp. 1-8.

## THERMO-ACOUSTICS OF BUNSEN TYPE PREMIXED FLAMES

### PROJECT AIM

The aim of this project is to characterize the acoustic behavior of flames (transfer function) experimentally in different combustion regimes (flat flame, Bunsen type laminar flames and turbulent flames) and to propose a phenomenological fit function for the measured flames. This information of transfer function is then used for (in)stability prediction of a simplified boiler using the acoustic network modeling approach.

### PROGRESS

- An experimental setup was build and measurement module/method is developed for identifying the thermo-acoustic behavior of transient/ turbulent flames.
- The acoustic response (i.e. Transfer function) of single Bunsen flames in different combustion regimes (laminar, transient and weakly turbulent) was measured.
- Dependence of the characteristics of the Transfer function due to changes in flame/perforation pattern is found.
- A relationship between system acoustic time delay ( $\tau_0$ ) and perturbation convective time ( $\tau_c$ ) is found for all measured flame types.
- The instability map of a simplified boiler (flame in tube) was obtained by the acoustic network modeling approach and is compared with experimentally obtained results.

### DISSERTATIONS

-

### SCIENTIFIC PUBLICATIONS

1. M. Hoeijmakers, V. N. Kornilov, M. Manohar, Ines Lopez, H. Nijmeijer and L.P.H. de Goey. Modeling thermo-acoustic combustion instability with the complex flame transfer function as a parameter, in Proceedings of the 17th International Congress on Sound and Vibration; Cairo, Egypt, 18-22 July 2010.

### PROJECTLEADERS

LPH de Goey

### RESEARCHTHEME

Complex dynamics of fluids

### PARTICIPANTS

Manohar, V Kornilov

### COOPERATIONS

AETHER

### FUNDED

STW, EU	
University	-
FOM	-
STW	-
NWO Other	25%
Industry	75%
TNO	-
GTI	-
EU	-
Scholarships	-

### START OF THE PROJECT

2006

### INFORMATION

Manohar

040 247 3819

manohar@tue.nl

www.wtb.tue.nl

<http://w3.wtb.tue.nl/nl/organisatie/>

combustion\_technology/

**PROJECT LEADERS**

JA van Oijen, LPH de Goey

**RESEARCH THEME**

Complex dynamics of fluids

**PARTICIPANTS**

N Speelman

**COOPERATIONS**

Bosch, Nefit BV

**FUNDED**

Bosch, Nefit BV

University -

FOM -

STW -

NWO Other -

Industry 100%

TNO -

GTI -

EU -

Scholarships -

**START OF THE PROJECT**

2010

**INFORMATION**

JA van Oijen

040 247 3133

j.a.v.oijen@tue.nl

www.combustion.tue.nl

**PROJECT AIM**

The purpose of this research is to develop a combustion control and diagnostics sensor based on flame ionization for condensing boiler applications. The flame ionization sensor measures the electrical conduction of the charged species generated during the combustion process to detect flashback and combustion instabilities, and to monitor equivalence ratio. In particular, the focus is on developing models to integrate the electric field emanating from the electrode with the lean premixed combustion process and ion reaction/transport submodels to simulate the electrode test results and optimize its position and shape.

**PROGRESS**

The project was started in October 2010 and since then literature in the field of combustion in the presence of electrical fields has been studied.

**DISSERTATIONS**

-

**SCIENTIFIC PUBLICATIONS**

-

## REDUCED CHEMISTRY MODELS FOR LARGE EDDY SIMULATIONS OF PARTIALLY-PREMIXED COMBUSTION

### PROJECT AIM

Development, implementation and validation of the Flamelet Generated Manifold (FGM) reduction method (combustion chemistry tabulation) for simulation (LES and DNS) of complex combustion chemistry in partially-premixed turbulent flames. The applicability of the Coherent Flamelet Model/ Flame Surface Density Model is validated for the simulation of stratified flames as can occur in (stationary) gas turbines. Direct Numerical Simulations (DNS) of a planar stratified Bunsen flame will allow the a priori validation of a combustion model which accounts for the subgrid fluctuations in mass burning rate. This model for the filtered mass burning rate can subsequently be used in Large Eddy Simulations (LES) of stratified flames.

### PROGRESS

In 2010, a paper on a priori analysis of different types of FGM databases for the simulation of the Sandia Flames has been published in *Flow, Turbulence and Combustion*. Currently, DNS simulations of turbulent planar Bunsen flames ( $Re_\lambda=35$ ;  $Ka=10$ ) are performed using a parallelized low-Mach DNS/LES code. Along the slot a stratification is applied as can be seen from the two instantaneous snapshots below in which the color denotes local equivalence ratio. From multiple fully-resolved realizations, both in terms of turbulence and reaction layer, data like local flame thickness and curvature is extracted to validate the applicability of the FGM reduction method for these flames. Subsequently, DNS results are filtered over sub-volumes corresponding to filter widths typically used in LES simulations. It is assessed whether the Flame Surface Density model is applicable for stratified flames as well as for premixed flames and, if so, how the mass burning rate should be modeled.

### DISSERTATIONS

-

### SCIENTIFIC PUBLICATIONS

1. A priori analysis of Flamelet Generated Manifolds for simulation of turbulent partially-premixed methane-air flames. (W.J.S. Ramaekers, J.A. van Oijen and L.P.H. de Goey, *Flow, Turbulence and Combustion*, 84:439-458 (2010).

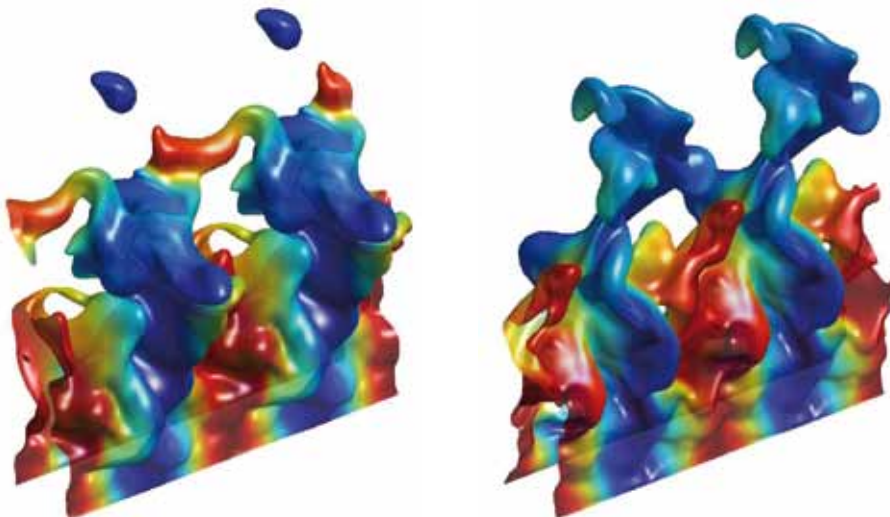

### PROJECT LEADERS

JA van Oijen, LPH de Goey

### RESEARCH THEME

Complex dynamics of fluids

### PARTICIPANTS

WJS Ramaekers

### COOPERATIONS

TIMECOP-AE (EU) project

Rolls-Royce Deutschland

### FUNDED

EU	
University	-
FOM	-
STW	-
NWO Other	-
Industry	-
TNO	-
GTI	-
EU	100%
Scholarships	-

### START OF THE PROJECT

2007

### INFORMATION

JA van Oijen

040 247 3133

j.a.v.oijen@tue.nl

www.combustion.tue.nl



**PROJECT LEADERS**

JA van Oijen, LPH de Goey

**RESEARCH THEME**

Complex dynamics of fluids

**PARTICIPANTS**

SE Abtahizadeh

**COOPERATIONS**

University of Groningen, TATA Steel, NUMECA.

**FUNDED**

STW, NVV, TATA Steel, NUMECA

University -

FOM -

STW 72%

NWO Other -

Industry 28%

TNO -

GTI -

EU -

Scholarships -

**START OF THE PROJECT**

2010

**INFORMATION**

JA van Oijen

040 247 3133

j.a.v.oijen@tue.nl

www.combustion.tue.nl

**PROJECT AIM**

In this project, MILD combustion by using highly preheated and diluted oxidizer and/or fuel streams will be studied to provide lower peak temperatures and as a result, low NO<sub>x</sub> emissions. Towards this end, 1D simulations of counterflow diffusion flames will be done to study the consequences of the composition of the fuel and/or oxidizer on spatial flame structure. Two-dimensional simulations of a coflow burner will be performed to compare with measurements. Based on the computational results obtained, a reduced chemical model for MILD combustion will then be developed and implemented in codes for simulation of turbulent combustion in JHC burners.

**PROGRESS**

The main characteristics of MILD combustion have been studied by modeling 1D counterflow diffusion flames (CFDF) in cases where the fuel and/or oxidizer streams were preheated and diluted with various amounts of products. Special attention is given to the influence of initial and boundary conditions of the simulations. Towards this end, a numerical model is implemented consisting of a network of PSR and CFDF solvers including exhaust gas recirculation (EGR) and heat loss effects. Comparison between different cases with the same amount of EGR shows that the fuel dilution case has the lowest temperature and the lowest NO. Unsteady igniting CFDF were also studied in detail for different cases with the same overall dilution level. Shorter ignition delay is observed when both streams are diluted instead of only one.

**DISSERTATIONS**

-

**SCIENTIFIC PUBLICATIONS**

1. S.E. Abtahizadeh, J.A. van Oijen, L.P.H. de Goey, Numerical study of dilution effects on main characteristics of Mild combustion, Winner of the second poster prize, COMBURA 2010, Maastricht, Oct. 2010.

**PROJECT AIM**

The focus of this project is on MILD combustion, which is characterized by a high degree of preheating and dilution of the reactants and offers the possibility of a sustainable, emission-free energy production. The project encompasses a multi-scale approach that starts with an exploration of the small-scale fundamental processes causing the outstanding properties of MILD combustion. This fundamental knowledge is then translated via numerical studies of lab-scale burners into design tools for large-scale industrial combustion devices. To investigate the reaction structures that arise in MILD combustion, high-fidelity numerical models will be employed.

**PROGRESS**

Combustion at MILD conditions has been investigated in numerical simulations of one-dimensional laminar counterflow diffusion flames employing detailed chemistry and transport models. These so-called flamelets will be used to generate look-up tables for accurate and efficient modeling of chemical kinetics in direct numerical simulations of turbulent jet-in-hot-coflow flames.

**DISSERTATIONS**

-

**SCIENTIFIC PUBLICATIONS**

-

**PROJECTLEADERS**

JA van Oijen

**RESEARCHTHEME**

Complex dynamics of fluids

**PARTICIPANTS**

JA van Oijen

**COOPERATIONS**

-

**FUNDED**

NWO (VIDI)

University -

FOM -

STW 50%

NWO Other 50%

Industry -

TNO -

GTI -

EU -

Scholarships -

**START OF THE PROJECT**

2010

**INFORMATION**

JA van Oijen

040 247 3133

[j.a.v.oijen@tue.nl](mailto:j.a.v.oijen@tue.nl)

[www.combustion.tue.nl](http://www.combustion.tue.nl)

## TWO-LINE ATOMIC FLUORESCENCE FOR TEMPERATURE MEASUREMENT IN FLAMES

### PROJECT LEADERS

LPH de Goey, NJ Dam

### RESEARCH THEME

Complex dynamics of fluids

### PARTICIPANTS

A Manteghi, LPH de Goey, RJM Bastiaans

### COOPERATIONS

-

### FUNDED

TUE

University 100%

FOM -

STW -

NWO Other -

Industry -

TNO -

GTI -

EU -

Scholarships -

### START OF THE PROJECT

2009

### INFORMATION

NJ Dam

040 2472117

n.j.dam@tue.nl

www.combustion.tue.nl

### PROJECT AIM

Developing two-line atomic fluorescence using Ga or In atoms to the measurement of temperature fields near auto-ignition of diesel-type fuels and under conditions typical for a diesel engine.

### PROGRESS

Spectra of both Ga and In atoms in flames have been seen, both in emission and excitation, using an ultrasonic seeder. A setup for seeding Ga atoms into hot gas has been tested, but needs modification. As an independent temperature measurement technique we consider Coherent Rayleigh-Brillouin Scattering. The setup has been developed at the Radboud University of Nijmegen. Test measurements on pure gases have been performed, and the effect of coherence time of the pump laser has been studied.

### DISSERTATIONS

-

### SCIENTIFIC PUBLICATIONS

-

## A STEPPED APPROACH IN EXPERIMENTAL RESEARCH TOWARDS LOWER SOOT EMISSION IN DIESEL ENGINES (FROM MOLECULE TO REAL ENGINE)

### PROJECT AIM

In order to understand the characteristics of soot formation in diesel combustion, this research aims at building a bridge between the process of soot formation in a real engine and soot formation in some more simple combustion devices. In addition, we focus on future fuel from second generation bio-fuels, as the production of biomass waste could be a good choice not only for a reduction of CO<sub>2</sub>, but also for lower soot emission. Consequently, the main conclusion of this research will involve the selection of second generation bio-fuel for lower soot emission from diesel engines, based on the studies of the effects of fuel structure and composition on soot formation in various combustion devices.

### PROGRESS

- 1) Made 10 kinds of C<sub>6</sub>H<sub>12</sub>O<sub>6</sub>, 1,2 fuels and blends with primary reference fuels (PRF) with the same Cetane Number and the same oxygen percentage;
- 2) Completed the measurements of the characteristics of combustion and emission of first 5 kinds of blends on full metal-engine;
- 3) Got stable flame of the first 5 kinds of blends on the high-pressure burner (HPVB);
- 4) Preparation of the measurements of soot formation of these blends on the HPVB.

### DISSERTATIONS

-

### SCIENTIFIC PUBLICATIONS

1. Lei ZHOU, C.A.J.Leermakers, M.H.de Oliveira, C.C.M.Luijten, N.J. Dam, L.P.H de Goey, "Research of Soot Emission of Alternative Fuels by a Combination of Engine Tests and Laser Diagnostics", EGS (European Graduate School on Sustainable Energy Technology) meeting, Nyborg, 9th. Dec. 2010.

### PROJECT LEADERS

LPH de Goey

### RESEARCH THEME

Mathematical and computational methods for fluid flow analysis

### PARTICIPANTS

L Zhou, CAJ Leermakers, MH de Oliveira, CCM Luijten, NJ Dam

### COOPERATIONS

DAF, Lund University

### FUNDED

European Graduate School	
University	-
FOM	-
STW	-
NWO Other	-
Industry	-
TNO	-
GTI	-
EU	100%
Scholarships	-

### START OF THE PROJECT

2009

### INFORMATION

L ZHOU

040 247 3731

l.zhou@tue.nl

www.combustion.tue.nl

#### PROJECT LEADERS

CCM Luijten

#### RESEARCH THEME

Complex dynamics of fluids

#### PARTICIPANTS

CCM Luijten, MH de Andrade  
Oliveira, M Yu, MD Boot

#### COOPERATIONS

DAF Trucks NV, Lund University

#### FUNDED

TUE	
University	100%
FOM	-
STW	-
NWO Other	-
Industry	-
TNO	-
GTI	-
EU	-
Scholarships	-

#### START OF THE PROJECT

2005

#### INFORMATION

CCM Luijten  
040 2475347  
C.C.M.Luijten@tue.nl  
www.combustion.tue.nl

#### PROJECT AIM

This project aims to make a cross-coupling between developments in fuels and engines. On the engine side, the most important (class of) new combustion concept is PCCI: premixed charge compression ignition. PCCI, however, puts different requirements to the fuel than conventional combustion (more specifically, a lower CN is required to enhance premixing). On the fuels side, important trends are the introduction of alternative fuels: biodiesel, ethanol and synthetic fuels, but also more dedicated fuels that were identified as promising with respect to (low) emissions in earlier research. By studying these "new" fuels in a variety of test setups (including a diffusion burner, a high pressure cell for spray studies and several engines), a broad spectrum of data is gathered on the combustion behaviour of these fuels.

#### PROGRESS

Two papers on real gas effects in sprays, conceived in 2009, were published in 2010 [1,2]. The high pressure cell (HPVB) for detailed fuel studies was utilized for two measurement campaigns at Lund University, to lay the groundwork for advanced laser diagnostics at elevated pressures (see project of M.H. de Andrade Oliveira). The Eindhoven High Pressure Cell (for spray studies), was utilized to do some dual fuel explorative tests for Wärtsilä Finland [3], see also project of M. Yu. Results of earlier work to check the possibility of using thermosphosphors for temperature measurements after precombustion, were published in 2010 [4]. We continued to explore two ideas of MD Boot, resulting in several additional publications.

#### DISSERTATIONS

1. M.D. Boot, Approaches to improve mixing in compression ignition engines, PhD.Thesis, 2010, Technische Universiteit Eindhoven. Advisors: R.S.G. Baert, L.P.H. de Goey. Co-advisor: C.C.M. Luijten.

#### SCIENTIFIC PUBLICATIONS

1. C.C.M. Luijten, C. Kurvers, Real gas effects in mixing-limited diesel spray vaporization models, *Atomization and Sprays*, 20(7), 595-609, (2010).
2. C. Kurvers, C.C.M. Luijten, Real Gas Effects in Siebers' Mixing-limited Spray Vaporization Model, *SAE Technical Papers*, -, 2010-01-1497, (2010).
3. M. Yu, C.C.M. Luijten, Project Report: dual fuel gas-diesel direct injection (Wärtsilä / TU/e confidential).
4. M. Yu, G. Särner, C.C.M. Luijten, M. Richter, L.E.M. Aldén, R.S.G. Baert, L.P.H. de Goey, Survivability of thermographic phosphors (YAG:Dy) in a combustion environment, *Meas. Sci.Techn.*, 21(3), 037002, (2010).
5. M.D. Boot, C.C.M. Luijten, L.M.T. Somers, E.P. Rijk, B.A. Albrecht, Spray Impingement in the Early Direct Injection Premixed Charge Compression Ignition Regime, *SAE Technical Papers*, -, 2010-01-1501, (2010).
6. J.J.E. Reijnders, M.D. Boot, C.C.M. Luijten, L.P.H. de Goey, P.J.M. Frijters, Porous fuel air mixing enhancing nozzle (PFAMEN), *SAE Int. J. Engines*, 2(2), 400-410, (2010).
7. R.H.L. Eichhorn, M.D. Boot, C.C.M. Luijten, Throttle Loss Recovery using a Variable Geometry Turbine, *SAE Technical Papers*, -, 2010-01-1441, (2010).
8. R.H.L. Eichhorn, M.D. Boot, C.C.M. Luijten, Waste energy driven air conditioning system (WEDACS), *SAE Int. J. Engines*, 2(2), 477-492, (2010).
9. C.C.M. Luijten, Spray combustion in engines, in *J.M.B.C. Course on Combustion*; Editors: J.A. van Oijen, L.P.H. de Goey and D.J.E.M. Roekaerts, 353-390, Technische Universiteit Eindhoven / J.M. Burgerscentrum.

## TOWARDS CLEAN DIESEL ENGINE COMBUSTION (SUB PROJECT: CHARACTERIZATION OF MIXTURE STRATIFICATION IN AN OPTICALLY ACCESSIBLE ENGINE)

### PROJECT AIM

Premixed charge compression ignition (PCCI) is one of the most promising combustion strategies for internal combustion engines, since PCCI combustion is able to realize very low soot and nitric oxide emissions while maintaining high fuel efficiency. To achieve PCCI combustion with limited heat release rates, the influence of charge stratification on combustion will be investigated. In this project methods are investigated to achieve and measure charge stratification. The mixing process is investigated by measuring in-cylinder velocities using time resolved particle image velocimetry (TR-PIV). Also the spray injection is investigated in combination with PIV.

### PROGRESS

Time resolved PIV measurements have been performed on an optically accessible engine as a function of crank angle position, position in cylinder, compression ratio and rotational speed. The setup is updated with a new cylinderhead and dedicated injection equipment. The mixing of multiple spray injections have been investigated using TR-PIV as well. In the final year of this project, 2011, combusting sprays will be investigated and in-cylinder temperature fields are measured using toluene-PLIF.

### DISSERTATIONS

-

### SCIENTIFIC PUBLICATIONS

-

### PROJECT LEADERS

LPH de Goey

### RESEARCH THEME

Complex dynamics of fluids

### PARTICIPANTS

RPC Zegers, M Yu, NJ Dam, CCM Luijten

### COOPERATIONS

Radboud University Nijmegen, DAF, Shell global solutions, Wärtsilä, TNO

### FUNDED

STW	
University	-
FOM	-
STW	90%
NWO Other	-
Industry	10%
TNO	-
GTI	-
EU	-
Scholarships	-

### START OF THE PROJECT

2007

### INFORMATION

RPC Zegers  
040 247 2393  
r.p.c.zegers@tue.nl  
www.combustion.tue.nl

## TOWARDS CLEAN DIESEL ENGINE COMBUSTION (SUB PROJECT: PCCI SPRAY COMBUSTION IN HIGH PRESSURE CELL)

### PROJECT LEADERS

LPH de Goey

### RESEARCH THEME

Complex dynamics of fluids

### PARTICIPANTS

M Yu, RPC Zegers, NJ Dam,  
CCM Luijten

### COOPERATIONS

Lund University, Radboud University  
Nijmegen, DAF, Shell global  
solutions, Wärtsilä, TNO

### FUNDED

STW	
University	-
FOM	-
STW	85%
NWO Other	-
Industry	15%
TNO	-
GTI	-
EU	-
Scholarships	-

### START OF THE PROJECT

2007

### INFORMATION

M Yu  
040 247 5995  
m.yu@tue.nl  
www.combustion.tue.nl

### PROJECT AIM

Premixed charge compression ignition (PCCI) is one of the most promising combustion strategies for internal combustion engines, since PCCI combustion is able to realize very low soot and nitric oxide emissions while maintaining high fuel efficiency. To obtain a more detailed understanding of PCCI combustion process, we aim to investigate a limit set of fuel spray mixing/reacting events.

The objectives include:

- Characterize of flow/temperature field prior to fuel injection (thermophosphor, Rayleigh Scattering, Raman Scattering etc.)
- Image the spray behavior and mixing progress during/after injection (Schlieren, LIF, etc.)
- Build an experimental database for numerical models.

### PROGRESS

The setup for Rayleigh Scattering and Raman Scattering method has been build, the evaluation of both methods is in progress. Schlieren and laser light scattering measurements have been performed on an optically accessible constant volume high pressure cell. The survivability of thermal graphic phosphors in a combustion environment has been tested. Experimental work on Dual fuel injection has been performed but the injector is not suitable for the Eindhoven Higher Pressure Cell (EHPC) condition. The LIF technique developed at RUN, to measure 2D temperature fields quantitatively, is being prepared in EHPC.

### DISSERTATIONS

-

### SCIENTIFIC PUBLICATIONS

1. M. Yu, G. Särner, C.C.M. Luijten, M. Richter, L.E.M. Aldén, R.S.G. Baert, L.P.H. de Goey, Survivability of thermographic phosphors (YAG:Dy) in a combustion environment, Meas. Sci. Techn., 21(3), 037002, (2010).

# DEVELOPMENT AND APPLICATION OF A LAMINAR COFLOW BURNER TO STUDY COMBUSTION OF MODERN AUTOMOTIVE (BIO-)FUELS AT HIGH PRESSURE, USING ADVANCED LASER DIAGNOSTICS

## PROJECT AIM

It is attempted to build a bridge between laminar flame burners (in which simple fuels are burnt at atmospheric pressure) and the much more complex and demanding environment found in practical combustion engines. This is accomplished by designing and constructing a high pressure vessel and diffusion burner and integrating these with an evaporation system. This setup will enable the study of realistic automotive (bio-) fuels, applying advanced optical diagnostics techniques that will be assessed in cooperation with the Lund Institute of Technology. This assessment will shed light on the applicability of these methods in sooty environments at high pressure.

## PROGRESS

Last year, it was carried out, in experimental setup described above and in the references below, an extensive laser diagnostic measurement campaign (of about 6 months) at Lund University (Sweden). The experiments characterized the combustion behavior of important surrogate liquid fuels. This was done by measuring the important parameters as OH (hydroxyl radicals), PAH (polycyclic aromatics hydrocarbons) and soot (particulate matter) at several operational conditions. Also investigations about the behavior of laser some techniques has been done at elevated pressure and is under analysis. The experimental data obtained in this campaign is currently been used by modelers involved in Computational Fluid Dynamics (CFD) at TU/e to assess and improve their models. Besides that, the capabilities of this experimental setup have been extended by integrating a highly accurate injection system allowing investigations in laminar flames of gaseous fuels doped with very small amounts ( $\pm 2000$  ppm) of liquid compounds. This extension and approach (doped flames) increase the possibilities for experimental investigation of a wide range of liquid fuels (also the more aggressive ones) due to the small amounts needed. The first use of this capability was done in cooperation with another PhD student when the free-radical chemistry of tar was experimentally and numerically investigated. Furthermore, a heat flux burner was integrated with a high pressure vessel and new measurements of burning velocities at elevated pressures using the heat flux method were carried out. At the moment the writing of the thesis and papers are in progress.

## DISSERTATIONS

-

## SCIENTIFIC PUBLICATIONS

1. M. H. de Andrade Oliveira, A. Manteghi, L. M. Verhoeven, P. R. Bloemen, C.C.M. Luijten, N. Dam, L.P.H. de Goey, Qualitative measurements of PAH, soot and OH in a laminar co-flow flame doped with aromatics compounds, Freising, Germany, European Graduate School on Sustainable Energy Conference Poster (2010).
2. M.H. de Andrade Oliveira, L.M. Verhoeven, C.C.M. Luijten, J.A. van Oijen, L.P.H. de Goey, Laminar co-flow flames doped with polycyclic aromatic hydrocarbons - an experimental and numerical study, , Beijing, China, 33rd International Symposium on Combustion (2010).
3. M.H. de Andrade Oliveira, H. Bladh, N.-E. Olofsson, J. Johnsson, P.-E. Bengtsson, L.P.H de Goey, Experimental characterization of soot formation in hydrocarbon liquid fuel, Beijing, China, 33rd International Symposium on Combustion (2010).

## PROJECT LEADERS

CCM Luijten, LPH de Goey, M Aldén

## RESEARCH THEME

Complex dynamics of fluids

## PARTICIPANTS

MH de Andrade Oliveira

## COOPERATIONS

Lund Institute of Technology (Sweden).

## FUNDED

TU/e, EU (Large Scale Facility at Lund University, optical diagnostic measurements)

University 100%

FOM -

STW -

NWO Other -

Industry -

TNO -

GTI -

EU -

Scholarships -

## START OF THE PROJECT

2007

## INFORMATION

MH de Andrade Oliveira

40 247 5995

M.H.Oliveira@tue.nl

www.combustion.tue.nl



# DEVELOPING COMPREHENSIVE DIESEL COMBUSTION MODEL FOR HDDI TO PREDICT HEAT RELEASE RATE AND EMISSIONS (MAINLY SOOT)

## PROJECT LEADERS

LMT Somers, LPH de Goey

## RESEARCH THEME

Mathematical and computational methods for fluid flow analysis

## PARTICIPANTS

S Ayyapureddi

## COOPERATIONS

DAF Trucks Eindhoven,  
TNO Eindhoven

## FUNDED

Senter Novem	
University	-
FOM	-
STW	-
NWO Other	90%
Industry	10%
TNO	-
GTI	-
EU	-
Scholarships	-

## START OF THE PROJECT

2009

## INFORMATION

Sridhar Ayyapureddi  
040 247 3731  
s.ayyapureddi@tue.nl  
www.tue.nl

Enthalpy variation (scatter plot) of  
incylinder gas at different CA

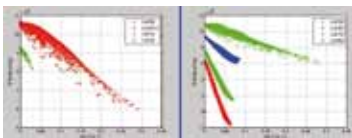

## PROJECT AIM

The prime aim of the current project is to use reduced chemical reaction models to model detailed chemistry of diesel combustion, in a way to reduce the cost and time involved in numerical simulation.

- Accounting heat losses using enthalpy variation effect during HDDI diesel engine combustion
- Modeling diesel soot. This can be realised with an attempt by coupling FGM\* with STARCD\*\* for non-premixed or diffusion flames to model conventional diesel combustion. And introducing extended mechanism for emissions reaction mechanisms

## PROGRESS

A study was carried out to investigate the possibility of using partially premixed counter flow flames (PPCFs) along with pure diffusion counter flow flames (DCF) in diesel combustion chemistry tabulation. To study the influence of turbulent flow, the flamelet manifold is constructed based on these PPCFs and the database is implemented in CFD (STAR CD) to model diesel spray combustion in a constant volume chamber. The inferences from this study of the igniting behavior of DCFs & PPCFs is that no significant change in the ignition timing (ignition delay) is formed whereas the position of ignition location differs, which might affect the flame liftoff length. Enthalpy variation during the engine cycle is studied to estimate the relevant enthalpy values for the oxidizer and fuel stream for flamelet calculations. This is important in order to capture the enthalpy defect due to the radiation and cooling losses in-situ which effect the emission formation during the diesel combustion. In the present study even without heat-loss, the enthalpy scatter plots with enthalpy distribution as shown in Fig1. As such an additional control variable (enthalpy) will be implemented to model diesel combustion. The phenomenological soot models gained good attention in recent literature and a good literature survey was carried out and a summary report on literature survey was written with the evolution of 9-step soot models. The phenomenological soot model includes global rate expressions for physical processes of particle inception, surface growth, coagulation, and oxidation to account for the rate of change of particle number density, soot volume fraction, precursor radicals and growth. The complete methodology comprises of three major steps – turbulent flow modeling to solve fuel-air mixing which resolves mixture fraction - modeling ignition, combustion using sources of progress variable from pre-tabulated chemistry which was build based on 1D flamelet code - calculating the source terms for soot related variables from the phenomenological soot model. This attempt is to investigate the possibility to implement soot models with chemistry by decoupling soot and gas-phase chemistry. The main challenge is to close the source terms variances by incorporating the effects of turbulent mixing on oxidation of soot.

## DISSERTATIONS

-

## SCIENTIFIC PUBLICATIONS

1. Ayyapureddi, L.M.T. Somers, L.P.H. de Goey, Modeling Diesel Spray Combustion Using Partially Premixed Flames in Flamelet Generated Manifold, 8th Asian-Pacific Conference on Combustion, Hyderabad, India (2010).

## CROSSING THE COMBUSTION MODES IN DIESEL ENGINES (XCiDE)

### PROJECT AIM

The development of a well established understanding of the processes occurring in the cylinder in different combustion regimes will be indispensable since new combustion concepts make diesel engines much more complex. The project aims to gain a better understanding of the new combustion concepts and develop numerical models that capture the complex combustion phenomena in these concepts. For the latter the FGM approach will be extended and applied in a CFD approach. To validate the models and even more to increase the fundamental knowledge of the new combustion concepts, high speed laser diagnostic techniques are developed. Application of these techniques to an optically accessible engine will help to understand and possibly explore new pathways for future engines and combustion concepts.

### PROGRESS

As PCCI-like combustion is governed by auto ignition and not by flame propagation, multi-zone approaches are believed to be a feasible approximation for this combustion regime. Still, a CFD model is utilized to estimate the mixing event which is required as an initial condition for the multi-zone modeling. The interaction between CFD and multi-zone model is well accomplished and the effects of different stratification levels and inter-zonal mixing is studied. The optically accessible engine has been equipped with a Delphi prototype fuel injector and a cylinder pressure indication system. For excitation of minor combustion species, a Sirah Credo HS dye laser has been acquired. The current high speed camera has been equipped with Intensified Relay Optics to intensify the UV signal of the fluorescing minor species. This combination of equipment is subject to further tests for a proof of concept.

### DISSERTATIONS

-

### SCIENTIFIC PUBLICATIONS

1. U. Egüz, C.A.J. Leermakers, L.M.T. Somers and L.P.H. de Goey, 'Multi-zone Modeling of PCCI Combustion with CFD Coupling for Stratification', Proceedings of Spec. 2010, Tenerife, 16-18 June 2010.

### PROJECT LEADERS

LPH de Goey, LMT Somers, NJ Dam

### RESEARCH THEME

Mathematical and computational methods for fluid flow analysis

### PARTICIPANTS

XU Egüz, CAJ Leermakers

### COOPERATIONS

DAF

### FUNDED

STW, DAF, Delphi, Shell, Avantium University	-
FOM	-
STW	-
NWO Other	70%
Industry	30%
TNO	-
GTI	-
EU	-
Scholarships	-

### START OF THE PROJECT

2009

### INFORMATION

U Egüz  
040 247 3286  
u.eguz@tue.nl

CAJ Leermakers  
c.a.j.leermakers@tue.nl  
www.combustion.tue.nl

**PROJECT LEADERS**

LPH de Goey, LMT Somers

**RESEARCH THEME**

Mathematical and computational methods for fluid flow analysis

**PARTICIPANTS**

C Bekdemir, M Meijer

**COOPERATIONS**University of California, San Diego  
Institut Français du Pétrolé (IFP)**FUNDED**

STW, DAF/PACCAR, Shell	
University	-
FOM	-
STW	90%
NWO Other	-
Industry	10%
TNO	-
GTI	-
EU	-
Scholarships	-

**START OF THE PROJECT**

2008

**INFORMATION**C Bekdemir  
040 247 3286  
c.bekdemir@tue.nl  
www.combustion.tue.nlM Meijer  
m.meijer@tue.nl  
www.combustion.tue.nl

Three snapshots of a simulation of combustion in a diesel engine showing the temperature distribution and fuel spray.

**PROJECT AIM**

Development, implementation and validation of a surrogate fuel concept for diesel engine combustion. The project combines both experimental and numerical work. The aim for the experimental part is to study surrogate fuels under engine relevant conditions in different fundamental set-ups with advanced optical diagnostics. The blend will be adapted such that both chemical and physical properties match the Diesel fuel as close as possible. The numerical work is performed by means of RaNS/LES and Flamelet Generated Manifold (FGM) based CFD in idealized and real engine conditions. Ultimately leading to a combined approach that can be applied to simulate fuel spray combustion and predict emission formation in engines, accurately and efficiently.

**PROGRESS**

In modern diesel engines, spray formation and combustion are the main processes that challenge engineers. Several ways to model fuel sprays (flow and turbulence) exist starting using RaNS and LES approaches. The latter can be much more detailed in the sense that they resolve large eddies and therefore inherently introduce stronger inhomogeneity like observed in practice. Concerning ignition and combustion a tabulated chemistry approach (FGM) is to be adopted. In order to apply these models successfully in the design of engines, appropriate and accurate diesel fuel characteristics have to be captured. On one hand, the thermo-physical properties of the fluid are important due to the vaporization and mixing processes that are involved. On the other hand, reaction kinetics plays an important role as the gas phase combusts. Since diesel fuel consists of many different hydrocarbon components it is a very complex fuel to model. Therefore a surrogate fuel will be developed to use in realistic injection and combustion simulations. Experiments in a constant volume combustion chamber are executed to study the behaviour of n-heptane fuel injections. Different optical (laser) diagnostics are implemented together with (high speed) camera systems. Other experimental set-ups are of interest as well. A start has been made with the implementation of a high pressure co-flow burner which is suitable to test diesel surrogate fuels. A complete diesel engine test bench is under construction where the final surrogate fuel candidate can be compared to a standard diesel in terms of combustion phasing and emission formation.

**DISSERTATIONS**

-

**SCIENTIFIC PUBLICATIONS**

1. C. Bekdemir, E.P. Rijk, L.M.T. Somers, L.P.H. de Goey, B.A. Albrecht, On the Application of the Flamelet Generated Manifold (FGM) Approach to the Simulation of an Igniting Diesel Spray, SAE Technical Paper, 2010-01-0358
2. C. Bekdemir, L.M.T. Somers, L.P.H. de Goey, Modeling diesel engine combustion using pressure dependent Flamelet Generated Manifolds, Proceedings of the Combustion Institute 33 (2011) 2887-2894.

## ENGINE EFFICIENCY : MODELING FUEL-AIR MIXING AND AUTO-IGNITION IN A DIESEL ENGINE-LIKE ENVIRONMENT

### PROJECT AIM

Numerically study fuel-air mixing, auto-ignition and combustion in partially Premixed Charge Compression Ignition (PCCI) engine condition, using the FGM method along with the Livengood-Wu method for autoignition. Study fuels with different auto-ignition behavior and their effects on combustion. Also FGM generated by performing perfect stirred reactor calculation will be explored.

### PROGRESS

FGM method has been developed to study combustion at diesel engine condition. The method is to build manifolds through a series of perfect stirred reactor calculations. A Livengood-Wu(LW) method is designed to study autoignition delay effects on combustion. Fuels with different autoignition delay are being studied, both experimentally and numerically, to examine the designed FGM-LW method. In the experiment, fuel sprays are injected into pressurized constant volume chamber, mimic a diesel engine condition at combustion. STAR-CD is used for CFD modeling, n-heptane and iso-octane are the two fuels selected to study. Pressure rise due to heat release in the chamber are studied both experimentally and numerically, followed by further investigation of flame structure from modeling work.

### DISSERTATIONS

-

### SCIENTIFIC PUBLICATIONS

-

### PROJECT LEADERS

LMT Somers

### RESEARCH THEME

Mathematical and computational methods for fluid flow analysis

### PARTICIPANTS

Z Hu

### COOPERATIONS

Eindhoven University of Technology (TU/e); Shell Global Solutions

### FUNDED

EU Marie Curie ToK  
Industry-Academia Partnership Scheme "engine efficiency"  
University 33%

FOM -

STW -

NWO Other -

Industry -

TNO -

GTI -

EU 67%

Scholarships -

### START OF THE PROJECT

2009

### INFORMATION

Z Hu

+44 151 373 7290

Hu.Zhixin@shell.com

www.combustion.tue.nl

#### PROJECT LEADERS

RJM Bastiaans

#### RESEARCH THEME

Mathematical and computational  
methods for fluid flow analysis

#### PARTICIPANTS

JA van Oijen, LPH de Goey, Y  
Shoshin

#### COOPERATIONS

MS Day, A Donini, A Fancello,  
A Verbeek, T Cardoso de Souza,  
M Goswami, S Mukhopadhyay,  
A Konnov, R Hermanns

#### FUNDED

University, STW, EU FP7

University 50%

FOM -

STW -

NWO Other 25%

Industry 25%

TNO -

GTI -

EU -

Scholarships -

#### START OF THE PROJECT

2010

#### INFORMATION

RJM Bastiaans

040 247 4836

r.j.m.bastiaans@tue.nl

www.combustion.tue.nl

#### PROJECT AIM

The aim of the project is to develop credible physical models to simulate turbulent (partially) premixed combustion in gas turbines. This is conducted by starting with a reduction of the chemistry by application of Flamelet Generated Manifolds technique in combination with Direct Numerical Simulation. Turbulent closures are tested and appropriate LES and RANS models are developed. More and more physics is taken into account by including diffusion effects in the combustion and also extinction. In particular, the use of hydrogen as energy carrier is investigated. In particular: the flameballs project was started.

#### PROGRESS

Successful simulations FGM-DNS simulations are presented in the literature. It is found that the effect of flame stretch can be successfully taken into account in these simulations. Thus turbulent combustion by using LES and RANS is possible. These kind of calculations are carried out and presented in literature for several applications. It is also shown that the turbulent source term of the conversion can be modeled accurately based on the stretch theory of de Goey for methane combustion. Besides this several technical issues connected to the interaction of models and numerics are published. The influence of the highly diffusive effect of hydrogen addition to methane on a turbulent lean slot burner is investigated. Moreover more applications are studied and published.

#### DISSERTATIONS

-

#### SCIENTIFIC PUBLICATIONS

1. R.T.E. Hermanns, A. Konnov, R.J.M. Bastiaans, L.P.H. de Goey, K. Lucka, H. Köhne, Effects of temperature and composition on the laminar burning velocity of  $\text{CH}_4 + \text{H}_2 + \text{O}_2 + \text{N}_2$  flames, *Fuel*, 89(1), 114-121, (2010).
2. J.A.M. de Swart, R.J.M. Bastiaans, J.A. van Oijen, L.P.H. de Goey, R.S. Cant, Inclusion of preferential diffusion in simulations of premixed combustion of hydrogen/methane mixtures with flamelet generated manifolds., *Flow, Turbulence and Combustion*, 85, 473-511, (2010).

# FLAME BALLS, CELLS AND CUSPS IN ULTRA-LEAN HYTHANE-AIR (FLAME BALLS)

## PROJECT AIM

This project is a continuation of the STRELA project. The main scientific objective of the proposed research is to establish mechanisms through which flame stretch affects propagation and extinction of lean (limit) single-front methane/hydrogen/air flames. To meet this objective, it is proposed to carry out a detailed experimental investigation of upward propagation and extinction of lean/limit flames in vertical cylindrical channels of different diameters, closed at the upper end and opened at the bottom end.

## PROGRESS

Ultra-lean hydrogen-methane air flames in a standard flammability tube have been studied experimentally. A transition from the flame-cap regime, observed near flammability limits, to the rising-bubble-like flames at increased fuel gas concentrations was observed and experimentally studied. Flame gas-dynamic structure was examined using the Particle Image Velocymetry Method and their temperature fields measured by the Thin Filament Pyrometry method. It was found that flame caps reside on the top of a moving upward massive of hot gas, which has the shape of a rising hot bubble. A local counter-flow gas dynamic pattern is formed at the top part of such bubble, and the flame cup surface is located along the stagnation surface. A weak secondary cone-like flame is observed below the main flame front of a flame cup. The transition to the bubble-like flame occurs without sudden changes of the flame shape, but with an abrupt increase, at least by the order of value, of the heat release rate in the flame front and abrupt changes in the combustion products flow pattern.

This is a project of a post-doc for 3 years.

## DISSERTATIONS

-

## SCIENTIFIC PUBLICATIONS

1. Y. Shoshin, J.A. van Oijen, A. Sepman, L.P.H. de Goeij, Experimental and computational study of the transition to the flame ball regime at normal gravity, Proc. Combust. Inst., 33, in press, 2010.
2. Y. Shoshin, L.P.H. de Goeij, Experimental study of lean flammability limits of methane/hydrogen/air mixtures in tubes of different diameters, Experimental Thermal and Fluid Science 34 (2010) 373– 380.

## PROJECT LEADERS

RJM Bastiaans, LPH de Goeij

## RESEARCH THEME

Complex structures of fluids

## PARTICIPANTS

Y Shoshin, J Oijen

## COOPERATIONS

NUON

## FUNDED

STW, NUON

University -

FOM -

STW 100%

NWO Other -

Industry -

TNO -

GTI -

EU -

Scholarships -

## START OF THE PROJECT

2010

## INFORMATION

R Bastiaans

040 247 4836

r.j.m.bastiaans@tue.nl

**PROJECT LEADERS**

RJM Bastiaans, LPH de Goey, BJ Geurts

**RESEARCH THEME**

Mathematical and computational methods for fluid flow analysis

**PARTICIPANTS**

Thiago Cardoso de Souza

**COOPERATIONS**

Twente University

**FUNDED**

STW	
University	-
FOM	-
STW	100%
NWO Other	-
Industry	-
TNO	-
GTI	-
EU	-
Scholarships	-

**START OF THE PROJECT**

2009

**INFORMATION**

Thiago Cardoso de Souza  
040 247 3731  
t.cardoso.de.souza@tue.nl  
www.tue.nl

**PROJECT AIM**

In the present research our goal is to optimizing turbulent combustion in low swirl burners by adding resonant mixing perturbations. To accommodate some requirements a multi-scale approach is proposed, in which lean premixed conditions should be combined, through a proper balance, with resonant smaller scale flow perturbations in order to increase the flame surface.

**PROGRESS**

At the moment the implementation of the Flamelet Generated Manifold as the combustion modelling technique coupled with CFD software has been finished. This gives the necessary tool to model turbulent premixed combustion in a realistic low swirl burner. Nevertheless, at this point a more fundamental study will start to be performed. This analysis will be addressed mainly in the context of DNS simulations performed in a simplified geometry. The detailed picture of turbulence and chemistry interactions will be obtained through these DNS simulations, which in turn will provide a detailed view of how turbulent scales, modulated through a forcing condition, can affect the structures of the flame surface and therefore lead to a possible increase of the local burning rate.

**DISSERTATIONS**

-

**SCIENTIFIC PUBLICATIONS**

1. T. Cardoso de Souza, R.J.M. Bastiaans, B.J. Geurts, L.P.H. de Goey, Numerical Analysis of a Swirl Stabilized Premixed Combustor with the Flamelet Generated Manifold approach, in Direct and Large-Eddy Simulation VIII; Editors: Kuerten, Geurts, Fröhlich, Armenio, Eindhoven, Netherlands, Accepted, (2010).

### PROJECT AIM

In the current project detailed knowledge for modeling of combustion with alternative fuels will be developed. This is done by means of detailed descriptions in the framework of Computational Fluid Dynamics (CFD). The ultimate goal is to predict the combustion process of gas turbines, including complex physical real fuel phenomena (temperature-traverse, NOx, preferential diffusion, thermo diffusive effects, extinction etc.). To that end the promising flamelet generated manifolds (FGM) technique will be extended in this project. The technique is developed in its basic form at TU/e and has been continuously tested and extended to more general situations over the last years.

### PROGRESS

Most of the time of this first year was used to study the bibliography associated to premixed combustion in gasturbines. Andrea: Introduction to Chem1D, generation of sets of laminar flamelets for hydrogen and methane combustion. Processing of the data of DNS of freely propagating premixed lean hydrogen flames. Ansys CFX installation and introduction, cold flow simulations of the SimVal combustor geometry, RANS and LES. Comparison with the available experimental data. Combustion RANS simulations with the available models of the SimVal and DLR-Stuttgart combustor. Sudipto: Chem1D familiarisation, generation of Methane-Air Flamelets, Building of manifold for Stratified combustion, Simulation of stratified combustion with low mach number LES code.

### DISSERTATIONS

-

### SCIENTIFIC PUBLICATIONS

1. Series ERCOFTAC - Conference: Direct and Large Eddy Simulation VIII - title: "A Priori Assessment of the Potential of Flamelet Generated Manifolds to Model Lean Turbulent Premixed Hydrogen Combustion", authors: A. Donini, R.J.M. Bastiaans, J.A. van Oijen, M.S. Day and L.P.H. de Goey.

### PROJECTLEADERS

RJM Bastiaans, LPH de Goey,  
JA van Oijen

### RESEARCHTHEME

Mathematical and computational  
methods for fluid flow analysis

### PARTICIPANTS

A Donini, S Mukhopadhyay

### COOPERATIONS

Siemens Power Generation (SPG)  
Rolls Royce Deutschland (RRD)

### FUNDED

University, STW, SPG, RRD  
University 50%  
FOM -  
STW 50%  
NWO Other -  
Industry -  
TNO -  
GTI -  
EU -  
Scholarships -

### START OF THE PROJECT

2010

### INFORMATION

RJM Bastiaans  
040 247 4836  
r.j.m.bastiaans@tue.nl



**PROJECT LEADERS**

RJM Bastiaans, AA Konnov, LPH  
de Goey

**RESEARCH THEME**

Mathematical and computational  
methods for fluid flow analysis

**PARTICIPANTS**

A Fancello, M Goswami

**COOPERATIONS**

European Turbine Network

**FUNDED**

ETN – H2 -IGCC

University -

FOM -

STW -

NWO Other -

Industry -

TNO -

GTI -

EU 100%

Scholarships -

**START OF THE PROJECT**

2009

**INFORMATION**

RJM Bastiaans

040 247 4836

r.j.m.bastiaans@tue.nl

**PROJECT AIM**

The H2-IGCC project, co-funded by the European Union's 7th Framework Programme for Research And Development, is based on the initiative outlined in the European Turbine Network's (ETN). The subproject regarding TU Eindhoven is divided in two parts: Numerical (I) and Experimental (II). Development of RANS and LES models will be based on Flamelet Generated Manifold (FGM) techniques with a special focus on preferential diffusion effects, partial unpremixedness and local extinction. These effects govern thermodiffusive instabilities which interact with turbulence in a complicated way. The Simulations will be done with the use of the open source software Open FOAM. (II) The design and development of gas turbine combustors used for H2-rich syngas IGCC combustion systems is based on detailed computer models that require combustion properties like flame speed and adiabatic flame temperature at conditions of high pressure and temperature. Hence, it is required to evaluate such combustion properties and have good knowledge of kinetics of Syngas (CO, CH4, H2, CO2) at gas turbine conditions.

**PROGRESS**

Numerical simulations on a dumped combustor with Open FOAM and simulations using a RANS solver for cold flow have been performed. A transport scalar passive transport equation with source term has been added to the model. At the moment, the progress of the work regards the setting up of Flamelet Generated Manifold technique an Open FOAM. About the experimental part, a new setup for the flame speed measurement regarding Hydrogen has been designed, with a particular attention to high pressure level. An updated Chemical Reaction Mechanism for H2/CO/O2 system with NOx prediction has been designed. Soon experiments will be performed for pressures greater than 5 bar.

**DISSERTATIONS**

-

**SCIENTIFIC PUBLICATIONS**

-

## ACTIVE MODEL-BASED SUPPRESSION OF THERMO-ACOUSTIC INSTABILITIES IN GAS-FIRED HOUSEHOLD BOILERS AND HEATERS

### PROJECT AIM

Applying active (feedback) control in order to suppress thermo-acoustic instabilities in gas-fired household boilers and heaters. A true model-based control mechanism, firmly rooted in combustion theory, based on our previous work concerning laminar flame dynamics will be used. Sensors and actuators are an explicit part of the research. In production type boiler equipment, an actual implementation will be tested.

### PROGRESS

Transfer functions of burner-stabilized flames are defined using a modal analysis technique. The correspondence of these transfer functions, without a dead time component, to measure transfer functions is near perfect. This means that linear control techniques are applicable to synthesize controllers to suppress thermo-acoustic instabilities. For the sensor and actuator research, studies to develop a cheap chemiluminescence sensor and to determine the actuator authority of an electric field on premixed flames are conducted. In order to quantify the influence of an electric field the change in laminar burning velocity (direct current) and change in OH\* radical chemiluminescence (alternating current) are measured.

### DISSERTATIONS

-

### SCIENTIFIC PUBLICATIONS

-

### PROJECT LEADERS

I Lopez, H Nijmeijer, LPH de Goey

### RESEARCH THEME

Complex dynamics of fluids

### PARTICIPANTS

JDBJ van den Boom, VN Kornilov, I Lopez, H Nijmeijer, LPH de Goey

### COOPERATIONS

ATAG Verwarming Nederland B.V., Remeha B.V., AGPO Ferolli, Honeywell B.V., TNO Industrie en Techniek, Bekaert Combustion Technology. B.V., Eco Ceramics B.V.

### FUNDED

STW	
University	-
FOM	-
STW	100%
NWO Other	-
Industry	-
TNO	-
GTI	-
EU	-
Scholarships	-

### START OF THE PROJECT

2004

### INFORMATION

I Lopez

040 247 2611

I.Lopez@tue.nl

[www.combustion.tue.nl](http://www.combustion.tue.nl)

## FUTURE FUELS

### PROJECT LEADERS

MD Boot

### RESEARCH THEME

Complex dynamics of fluids

### PARTICIPANTS

N Leermakers, L Zhou, B Somers, C Luijten, N Dam, E Hensen

### COOPERATIONS

Volvo Car (Sweden), DAF Trucks (Eindhoven), DSM (Geleen)

### FUNDED

STW /Province N-Brabant	
University	-
FOM	-
STW	100%
NWO Other	-
Industry	-
TNO	-
GTI	-
EU	-
Scholarships	-

### START OF THE PROJECT

2010

### INFORMATION

MD Boot  
040 246 2393  
M.D.Boot@tue.nl  
www.combustion.tue.nl

### PROJECT AIM

Future Fuels is a new research theme within the Combustion Technology Group (Prof. De Goey) of the TU/e. Main research questions are:

- What would the engine want to drink to produce low emissions?
- How can we produce such fuels from oil (initially) and biomass (later on)?

### PROGRESS

In the past year, low cetane (i.e. low reactive) fuels and co-burning of gaseous fuels were investigated in heavy-duty diesel engines. Both had an advantageous effect on overall engine performance, particularly soot emissions due to enhanced (pre-)mixing.

### DISSERTATIONS

-

### SCIENTIFIC PUBLICATIONS

1. J.J.E. Reijnders, M.D. Boot, C.C.M. Luijten, L.P.H. de Goey, P.J.M. Frijters, Porous fuel air mixing enhancing nozzle (PFAMEN), SAE Int. J. Engines, 2(2), 400-410, (2010).
2. M.D. Boot, C.C.M. Luijten, L.M.T. Somers, E.P. Rijk, B.A. Albrecht, Spray Impingement in the Early Direct Injection Premixed Charge Compression Ignition Regime, SAE Technical Papers, -, 2010-01-1501, (2010).
3. R.H.L. Eichhorn, M.D. Boot, C.C.M. Luijten, Throttle Loss Recovery using a Variable Geometry Turbine, SAE Technical Papers, -, 2010-01-1441, (2010).
4. R.H.L. Eichhorn, M.D. Boot, C.C.M. Luijten, Waste energy driven air conditioning system (WEDACS), SAE Int. J. Engines, 2(2), 477-492, (2010).





Prof.dr.ir. JJH Brouwers

The programme of the group covers theoretical, numerical and experimental research on selected subjects in process technology. The subjects range from fundamentals to applications. The aims are to contribute to scientific issues relevant to the field, to develop tools for applying scientific results on practical cases and to design machinery and apparatus using these results. Many research activities are carried out in co-operation with and with support of industry.

#### THE SUBJECTS OF RESEARCH ARE:

### 1. *Stochastic processes and turbulence*

The stochastic process of turbulence is a key issue in process technology, since fluid flow in process apparatus is generally turbulent and predicting flow quantities is a central issue in their design. A theory is being developed for stochastic turbulence, which involves asymptotically exact solution methods and reveals the truncation errors. Concerning numerical research, faster and more efficient numerical methods for DNS and LES models for particle-laden turbulent flow are being developed. Experimental research into inhomogeneous turbulence at intermediate and high Reynolds number is carried out by means of 3D-PTV in turbulent pipe flow.

### 2. *Phase-transitional flow*

Fluid flow in which a phase change occurs is of considerable importance in process technology. The research is focused on boiling, (dropwise) condensation and sublimation. The research is generic, aiming at results that are applicable in numeric codes and for the design of unit operations. As examples, the dependencies of drag and lift force coefficients on acceleration of bubbles and particles have been studied and the effect of the velocity field caused by condensation directly downstream of the inlet of a confined steam jet on self-similarity has been investigated. Current research focuses on inertia-dominated interaction of flow and bubbles or particles and on basic mechanisms of condensation and sublimation. The approach followed is analytical, experimental and numerical.

### 3. *Development of new process technology*

The insights gained in the first two topics are applied to new concepts of process technology, mainly in the area of rotational equipment, separation apparatus and heat and mass exchangers. These projects are carried out in close cooperation with industry and comprise the design, manufacturing and testing of new equipment. Centrifugal phase separation offers excellent opportunities for innovation. The group has a strong position in this field by the patented concept of rotational particle separation. A new development is the design where rotation is generated by swirl of the flow itself, which is particularly suited at high fluid pressures and receives much interest from the oil industry. A new in-house born idea is the wall-de-sublimator, which avoids the formation of aerosols by de-sublimating vapors on cooled surfaces of narrow-channeled heat exchangers. A relatively new means of ship propulsion is based on waterjets driven by pumps. The group studies the effects of non-uniform intake flow on performance and forces of the pump. A project on the development of a numerical method for unsteady flow in rotating machinery just started.

**PROJECT AIM**

In this project interaction between different kinds of particles and between particles and flow will be studied in which the properties of the particles, such as size, shape, temperature and chemical composition change in time because of combustion and flow of the surrounding gas. Particles will be treated as point particles, but detailed numerical simulations will be carried out to obtain correlations for the forces on a particle.

**PROGRESS**

An existing DNS code for Lagrangian simulations of point particles has been extended with equations for temperature and species concentration. Two-way coupling between gas and particle temperature has been incorporated.

**DISSERTATIONS**

-

**SCIENTIFIC PUBLICATIONS**

-

**PROJECTLEADERS**

JGM Kuerten

**RESEARCHTHEME**

Complex dynamics of fluids

**PARTICIPANTS**

E Russo, JGM Kuerten, CWM van der Geld

**COOPERATIONS**

JA van Oijen, Y Haseli (TU/e)

EM Gucho, G Brem, BJ Geurts (UT)

**FUNDED**

STW	
University	-
FOM	-
STW	100%
NWO Other	-
Industry	-
TNO	-
GTI	-
EU	-
Scholarships	-

**START OF THE PROJECT**

2010

**INFORMATION**

JGM Kuerten

040 247 2362

[j.g.m.kuerten@tue.nl](mailto:j.g.m.kuerten@tue.nl)

[www.wtb.tue.nl/woc/ptc](http://www.wtb.tue.nl/woc/ptc)

**PROJECT LEADERS**

CWM van der Geld

**RESEARCH THEME**

Complex dynamics of fluids

**PARTICIPANTS**

M Grooten, CWM van der Geld

**COOPERATIONS**

Klima, Verhulst, fac. Wsk, Innovation Handling

**FUNDED**

Faculteit W

University 100%

FOM -

STW -

NWO Other -

Industry -

TNO -

GTI -

EU -

Scholarships -

**START OF THE PROJECT**

2007

**INFORMATION**

CWM van der Geld

040 247 2923

c.w.m.v.d.geld@tue.nl

www.wtb.tue.nl/woc/ptc

**PROJECT AIM**

To increase our understanding of the basic mechanisms of dropwise condensation and of sublimation, and to apply the knowledge thus gained to the improvement of the design of compact condensers.

**PROGRESS**

The results of measurements in a dedicated set-up with infrared camera, high-speed camera, a new humidity sensor designed by Innovation Handling have been used to verify expectations based on maximum drop size dependencies of heat transfer and drainage rates. Two new types of compact condenser plates have been developed in cooperation with the group MATE of our faculty. They comprise special patterns of alternatively hydrophilic and hydrophobic plate material to promote drainage. Another type of plate condenser has been developed to enable direct comparison of dropwise and filmwise condensation. Measurements with these plates were completed and analyzed and results have been summarized in two publications, which were submitted.

**DISSERTATIONS**

-

**SCIENTIFIC PUBLICATIONS**

1. M.H.M. Grooten, C.W.M. van der Geld, The effect of the angle of inclination on the operation limiting heat flux of long R-134a filled thermosyphons. <http://link.aip.org/link/?JHR/132/051501>, ASME J. of Heat Transfer, 132(5), 1-30, (2010).
2. W. van Schaik, M.H.M. Grooten, T. Wernaart, C.W.M. van der Geld, High accuracy acoustic relative humidity measurement in duct flow with air, Sensors & Actuators A, 10, 7421-7433, (2010).
3. M.H.M. Grooten, C.W.M. van der Geld, The Importance of Drainage in Dropwise Condensation From Flowing Air-Steam Mixtures, in International Heat Transfer Conference (IHTC14); Editors: Jung-Ho Kim. Order No. I846DV, August 8-13, 2010 • Washington, DC, United States, ISBN 978-0-7918-3879, (2010).

**PROJECT AIM**

The aims of the project are the development and validation of a new physical model that can be used in the simulation of the heating process of fluids by direct steam injection at relatively high temperatures and short residence times. To this end a combination of the diffuse interface method and large-eddy simulation has been used and dedicated experiments have been carried out.

**PROGRESS**

The experimental results have been completed and analyzed. A model is made to facilitate interpretation of the results. The diffuse interface method has been extended to non-isothermal flow and simulations of colliding droplets have been studied for various values of the Prandtl and Weber number.

**DISSERTATIONS**

1. A. Pecenko, Numerical simulation methods for phase-transitional flow, PhD. Thesis, 2010, TU/e. Advisors: J.J.H. Brouwers, J.G.M. Kuerten, Co-advisor: C.W.M. van der Geld.
2. N. Clerx, Experimental study of direct contact condensation of steam in turbulent duct flow, PhD. Thesis, 2010, TU/e. Advisors: J.J.H. Brouwers, J.P. Celata, Co-advisor: C.W.M. van der Geld.

**SCIENTIFIC PUBLICATIONS**

1. A. Pecenko, J.G.M. Kuerten, C.W.M. van der Geld, A diffuse-interface approach to two-phase isothermal flow of a Van der Waals fluid near the critical point. *Int. J. Multiphase Flow*, 36(1), 558-569, (2010).
2. A. Pecenko, J.G.M. Kuerten, The Diffuse Interface Method with Korteweg Approach for Isothermal, Two-Phase Flow of a Van der Waals Fluid, in *Direct and Large-Eddy Simulation VII*; Editors: V. Armenio, B.J. Geurts, J. Fröhlich, Trieste, Italy, 375-380, (2010).

**PROJECTLEADERS**

CWM van der Geld, JGM Kuerten

**RESEARCHTHEME**

Complex dynamics of fluids

**PARTICIPANTS**

N Clerx, A Pecenko, CWM van der Geld, JGM Kuerten

**COOPERATIONS**

NIZO food research, Stork Food & Dairy Systems B.V.

**FUNDED**

STW	
University	-
FOM	-
STW	100%
NWO Other	-
Industry	-
TNO	-
GTI	-
EU	-
Scholarships	-

**START OF THE PROJECT**

2006

**INFORMATION**

CWM van der Geld  
 040 247 2923  
 c.w.m.v.d.geld@tue.nl  
 www.wtb.tue.nl/woc/ptc



#### PROJECT LEADERS

CWM van der Geld, JGM Kuerten

#### RESEARCH THEME

Complex dynamics of fluids

#### PARTICIPANTS

C Baltis, CWM van der Geld, JGM Kuerten.

#### COOPERATIONS

DAF, Spirotech B.V.

#### FUNDED

STW

University -

FOM -

STW 100%

NWO Other -

Industry -

TNO -

GTI -

EU -

Scholarships -

#### START OF THE PROJECT

2010

#### INFORMATION

CWM van der Geld

040 247 2923

c.w.m.v.d.geld@tue.nl

www.wtb.tue.nl/woc/ptc

#### PROJECT AIM

The effect of flow on boiling bubble detachment from a heated plane wall is investigated for the effects mentioned in the title. Experiments serve to validate a model based on the diffuse interface method that will be further developed.

#### PROGRESS

In 2010, new deforming bubble detachments have been recorded, highlighting the effect of viscosity. Experiments performed with a dedicated test rig in microgravity arranged by the parabolic flight of an airplane, in cooperation with IMFT in France, have been analyzed. A new analyzing tool has been developed. Experiments performed of intravenous boiling, for medical applications in a special test section have been analyzed and reported. In November 2010 ir. C. Baltis joined the team to work on the experiments mentioned in the title.

#### DISSERTATIONS

-

#### SCIENTIFIC PUBLICATIONS

1. C.W.M. van der Geld, R. van den Bos, P.W.M. van Ruijven, T. Nijsten, H.A. Neumann, M.J.C. van Gemert, The heat pipe resembling action of boiling bubbles in endovenous laser ablation, doi 10.1007/s10103-010-0780-2, *Lasers in Medical Science*, 25(6), 907-909, (2010).
2. C.W.M. van der Geld, Shape oscillations of a boiling bubble, *Multiphase Science and Technology*, 22(2), 157-175, (2010).
3. C.W.M. van der Geld, J.G.M. Kuerten, Axisymmetric dynamics of a bubble near a plane wall., *J. Fluid Mech.*, 640, 267-305, (2009).

# STATISTICAL ANALYSIS OF TURBULENT TWO-PHASE PIPE FLOW BY MEANS OF EXPERIMENTS

## PROJECT AIM

The aim of this research is to determine the statistical properties of inhomogeneous turbulence at intermediate and high Reynolds numbers and the effect of particles with inertia on these properties.

## PROGRESS

The previously implemented changes in the 3D PTV test set-up, amongst which three new cameras and an improved illumination system and new trajectory reconstruction software, turned out to have a big impact on the set-up. As a result of a year of struggling and testing the measurement accuracies and possibilities are well understood now. Flows of particles with inertia in water have been measured. More testing and measurements will be carried out next year.

## DISSERTATIONS

-

## SCIENTIFIC PUBLICATIONS

-

## PROJECTLEADERS

CWM van der Geld, JGM Kuerten

## RESEARCHTHEME

Complex dynamics of fluids

## PARTICIPANTS

JL Goes Oliveira, CWM van der Geld, JGM Kuerten

## COOPERATIONS

-

## FUNDED

TUE	
University	100%
FOM	-
STW	-
NWO Other	-
Industry	-
TNO	-
GTI	-
EU	-
Scholarships	-

## START OF THE PROJECT

2003

## INFORMATION

CWM van der Geld  
040 247 2923  
c.w.m.v.d.geld@tue.nl  
[www.wtb.tue.nl/woc/ptc](http://www.wtb.tue.nl/woc/ptc)

**PROJECT LEADERS**

JGM Kuerten

**RESEARCH THEME**

Complex dynamics of fluids

**PARTICIPANTS**

W Michalek, JGM Kuerten

**COOPERATIONS**Prof. dr. A. Soldati, Dr. C. Marchioli,  
University of Udine, Italy**FUNDED**

STW, TU/e, DEISA	
University	25%
FOM	-
STW	75%
NWO Other	-
Industry	-
TNO	-
GTI	-
EU	-
Scholarships	-

**START OF THE PROJECT**

2003

**INFORMATION**JGM Kuerten  
040 247 2362  
j.g.m.kuerten@tue.nl  
www.wtb.tue.nl/woc/ptc**PROJECT AIM**

The aim of this project is the study of dispersion of non-passive particles in turbulent non-isothermal channel flow by means of DNS and LES. Especially models for subgrid contributions in case LES is used for the fluid flow are developed and tested, both for particle velocity and particle temperature.

**PROGRESS**

Dispersion of non-passive particles in turbulent non-isothermal channel flow is studied by means of DNS and LES. A model for the subgrid contribution in the particle equation of motion has been developed and shows a substantial improvement in the statistical results of LES. The dynamic eddy-viscosity model and especially the approximate deconvolution model yield results which agree well with DNS results for a range of particle relaxation times. In 2010 DNS at  $Re_\tau=395$  has been performed and results are compared with LES. Moreover, an equation for temperature as a passive scalar has been added. It appears that ADM results for the temperature are less accurate than results based on the dynamic eddy-diffusivity model.

**DISSERTATIONS**

-

**SCIENTIFIC PUBLICATIONS**

-

**PROJECT AIM**

The aim of this research is to develop a model for the calculation of the thickness of deposition that results after evaporation of a solvent from a droplet and of the distribution of (bio)molecules on/in the substrate.

**PROGRESS**

Models for individual processes of evaporation, spreading and sorption of a microscopic drop on a porous or non-porous substrate have been further developed. The methods have been combined and validation with experimental results and results based on numerical simulation of the full Navier-Stokes equation has been performed. A start has been made with extension of the model for convection and diffusion of the dissolved phase to allow for vertical concentration dependence.

**DISSERTATIONS**

-

**SCIENTIFIC PUBLICATIONS**

1. D.P. Siregar, J.G.M. Kuerten, H.M.A. Wijshoff and L.T.M. van der Linden: Numerical simulation of the absorption of a droplet in a porous medium, in Porous media and its application in science, engineering and industry, AIP Conference proceeding vol. 1254, pp. 135-140.

**PROJECTLEADERS**

JGM Kuerten

**RESEARCHTHEME**

Complex dynamics of fluids

**PARTICIPANTS**

DP Siregar, CWM van der Geld, JGM Kuerten

**COOPERATIONS**

WUR, Philips Research. Océ

**FUNDED**

STW	
University	-
FOM	-
STW	100%
NWO Other	-
Industry	-
TNO	-
GTI	-
EU	-
Scholarships	-

**START OF THE PROJECT**

2008

**INFORMATION**

JGM Kuerten  
 040 247 2362  
[j.g.m.kuerten@tue.nl](mailto:j.g.m.kuerten@tue.nl)  
[www.wtb.tue.nl/woc/ptc](http://www.wtb.tue.nl/woc/ptc)



Prof.dr.ir. AA van Steenhoven



Prof.dr. A Dietzel



Prof.dr. H Zondag

Research in the field of Energy Technology at a Mechanical Engineering Department requires the combination of fundamental research together with the study of practical systems. Our group restricts its fundamental research to the field of Heat Transfer and the practical system study to Small-scale Energy Systems with a strong emphasis on Sustainability.

The approach is to combine advanced experimental, analytical and numerical techniques to investigate fundamental issues in heat transfer and to design, construct and test real energy conversion systems. In this way, the research also contributes to the engineering and research training of the mechanical engineering students. The research is concentrated on three topics:

#### **A. HEAT TRANSFER AND TRANSITIONAL FLOWS**

The research in this area is aimed at a better understanding of the fundamental characteristics of transitional flows in general. Flow cases that are studied are bypass transition along a flat plate (related to turbine blade cooling) and the mixed convection around a heated cylinder (related to electronics cooling). In these studies the attention is mainly focused on the physics of the 3D-transition of these types of flows and its influence on the heat transfer. Another research line concentrates on laminar (thermal) transport phenomena in compact fluid-dynamical systems.

#### **B. MICRO-SCALE HEAT TRANSFER**

The aim of this research line is to achieve a better understanding of the heat and mass transfer processes at the small scales. The focus is on evaporative cooling of electronic components, on multi-scale analyses to enhance the efficiency of compact heat storage and the dynamics of actuated super-paramagnetic particles as integrated fluid drivers in micro systems. On the smallest scales the physical processes on different scales are studied by coupling Molecular-Dynamics analyses with a Direct Simulation Monte Carlo model.

#### **C. HEAT-TRANSFER ENGINEERING**

The research activities in this area focus more on the system-level instead of the phenomenon-level. Two main research projects are fouling of heat exchangers as used in waste- incinerators and biomass-gasifiers, and heat transfer models for the human body under normal and surgical conditions.

More information about the research activities in these areas can be found on our website: [www.energy.tue.nl](http://www.energy.tue.nl)

**PROJECT AIM**

Transition to turbulence in a mixed convection and a wire-disturbed wake flow behind a circular cylinder is investigated within this project. Both experiments and numerical simulations are executed in order to assess the effect of several disturbances and to obtain a better understanding of the phenomena, which take place during transition to a turbulent flow.

**PROGRESS**

The three-dimensional transition of the flow behind a circular cylinder with a near-wake wire disturbance has been investigated experimentally using PIV and flow visualization techniques, as well as numerically using SEM simulations. The research revealed that by placing a small control wire parallel to the cylinder the shedding pattern behind the cylinder changes and Mode-C transition appears in the wake. The nature of the Mode-C instability consists of formation of secondary vortices with a period-doubling character. The spanwise wavelength of the instability is measured as 2.2 cylinder diameters, which is approximately the same as in Mode-E for the heated cylinder case. Extensive side-view plane and cross-stream plane PIV measurements have been performed to quantify the vortex dynamics and to gain insight into the physical phenomena.

**DISSERTATIONS**

-

**SCIENTIFIC PUBLICATIONS**

1. Yildirim, C.C.M. Rindt, A.A. van Steenhoven. Vortex dynamics in a wire-disturbed cylinder wake. Physics of Fluids, 22:094101, 2010.

**PROJECTLEADERS**

CCM Rindt, AA van Steenhoven

**RESEARCHTHEME**

Complex structures of fluids

**PARTICIPANTS**

I Yildirim, PR Bloemen

**COOPERATIONS**

GJF van Heijst, Fac. of Applied Physics, TU/e

**FUNDED**

FOM	
University	-
FOM	100%
STW	-
NWO Other	-
Industry	-
TNO	-
GTI	-
EU	-
Scholarships	-

**START OF THE PROJECT**

1996

**INFORMATION**

CCM Rindt  
040 247 2978  
c.c.m.rindt@tue.nl  
www.energy.tue.nl

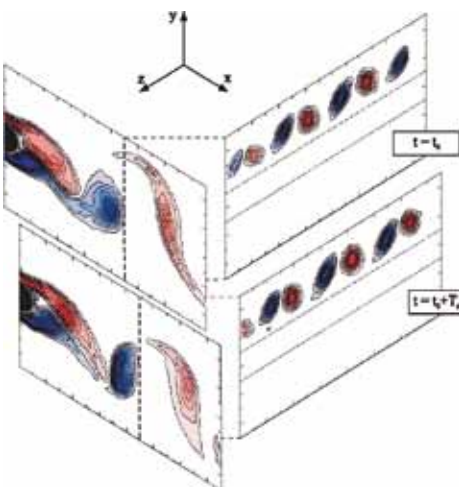

Side-view and cross-view vortical structures for the wired-cylinder case showing the period doubling effect.

**PROJECT LEADERS**

HC de Lange, AA van Steenhoven

**RESEARCH THEME**

Complex dynamics of fluids

**PARTICIPANTS**

PR Bloemen, J Klinkenberg

**COOPERATIONS**

L Brandt, D Henningson and  
P Schlatter, KTH Stockholm,  
Sweden

**FUNDED**

TU/e	
University	100%
FOM	-
STW	-
NWO Other	-
Industry	-
TNO	-
GTI	-
EU	-
Scholarships	-

**START OF THE PROJECT**

2000

**INFORMATION**

HC de Lange  
040 247 2129  
h.c.d.lange@tue.nl  
www.energy.tue.nl

**PROJECT AIM**

Bypass transition of a boundary layer takes place at high mainstream turbulence levels. It is governed by the intrusion of non-linear disturbances into the viscous sublayer. This study aims at understanding the nature of the transition process and also the control of the transitional process.

**PROGRESS**

Flows laden with hard, spherical particles have been considered using both modal and non-modal analysis. Two limits have been studied: heavy and light particles. In the latter case more interaction terms are included in the system, such as the added mass and fluid acceleration terms. The results so far showed that particles can result in an increase of the critical Reynolds number. However, non-modal analysis showed that particles have no effect on stability. For both heavy and light particles, it is found that the optimal interaction takes place when the particle interaction time equals the period of the disturbance wave. For light particles the optimal interaction takes place in a regime where the used Eulerian approach might not be valid. Therefore, the research will be extended with DNS of particle laden flows with finite sized particles to gain more insight in the nature of the instabilities. Besides this, particle behaviour, such as clustering and particle-particle interactions can be studied. Furthermore, in a water channel a combined visualization and PIV/PTV technique will be used to study both the onset and the development of the boundary layer instability with and without particles. These results will then be combined with the numerical studies. In addition, our transition delay research (co-funded through the EU FP6 project RI-031513 and the FP7 project RI-222919, for support within the DEISA Extreme Computing Initiative) lead to the conclusion that downstream travelling surface waves delay (or even erase) bypass transition (see figure).

**DISSERTATIONS**

-

**SCIENTIFIC PUBLICATIONS**

1. H.C. de Lange and L. Brandt, Drag reduction on external surfaces induced by wall waves, Proceedings Direct and Large-Eddy simulation 8, ed. H.Kuerten, Eindhoven, the Netherlands, 2010.

The effect of added downstream travelling waves on disturbances in a boundary layer subjected to main stream turbulence. At  $t=0$  (top) the control waves are added and on subsequent times the bypass transition is delayed and eventually even erased.

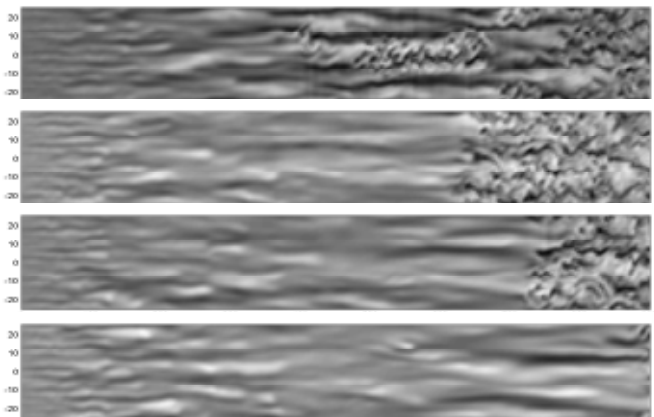

**PROJECT AIM**

Key issues in cutting-edge technologies (e.g. micro-electronics, lithographic systems) are massive heat removal and thermal homogenisation. Boiling heat transfer affords solutions to both issues and will play a central role in next-generation thermal-management schemes. However, to this end better control of the boiling process is essential. The study takes a first step towards this aim by the model-based development of control strategies for regulation of boiling under dynamic operating conditions in a representative 3D boiling system.

**PROGRESS**

Numerical and theoretical studies on the dynamics of the 2D closed-loop boiling system have been continued. A stronger link between the continuous and discrete models has been established so as to admit rigorous analyses using general nonlinear-systems methods. Moreover, succesful stabilisation and regulation of essentially heterogeneous states of the 2D system has been accomplished (left figure). Current activities focus on design of an observer and extension of the control strategy for stabilisation and regulation of 3D boiling states (right figure).

**DISSERTATIONS**

-

**SCIENTIFIC PUBLICATIONS**

1. R.W. van Gils, M.F.M. Speetjens, H. Nijmeijer, Feedback stabilisation of a one-dimensional nonlinear pool-boiling system, *Int. J. Heat Mass Transfer, Int. J. of Heat and Mass Transfer*, 53, 2393-2403, (2010).
2. R.W. van Gils, M.F.M. Speetjens, H. Nijmeijer, Feedback stabilisation of two-dimensional non-uniform pool-boiling states, in *Advanced Computational Methods and Experiments in Heat Transfer (Heat Transfer XI)*; Editors: B. Sundén, U. Mander and C.A. Brebbia, July 14-16, Tallin, Estonia, 215 – 226.
3. R.W. van Gils, M.F.M. Speetjens, H. Nijmeijer, Feedback stabilization of transition boiling states, in *Proceedings of the 2010 12th IEEE Intersociety Conference on Thermal and Thermomechanical Phenomena in Electric Systems (ITherm 2010)*, June 2 - 5, 2010; Bally's, Las Vegas, United States, paper044.

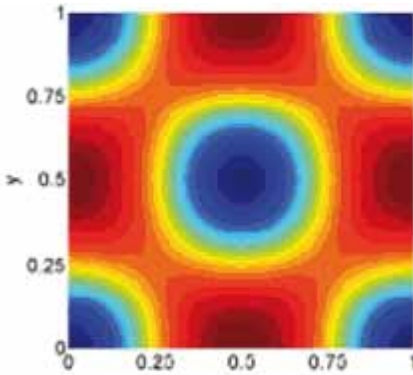
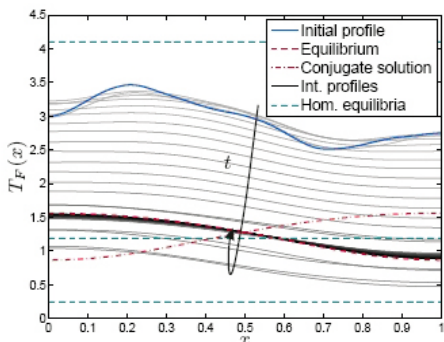

Formation and stabilisation of heterogeneous steady states on the fluid-heater interface of heater elements. Panel a: regulation of an initial temperature profile towards an unstable heterogeneous boiling state (dashed) in 2D system. Panel b: typical unstable state in 3D system; bluish and redish regions are “low” (wet) and “high” (dry) temperature zone.

**PROJECTLEADERS**

MFM Speetjens, H Nijmeijer

**RESEARCHTHEME**

Complex dynamics of fluids

**PARTICIPANTS**

RW van Gils

**COOPERATIONS**

A Reusken & S Maier-Paape, Dept. Mathematics, RWTH, Aachen, Germany, W Marquardt, Dept. Mechanical Engineering, RWTH, Aachen, Germany

**FUNDED**

TU/e-W until May 2010; HTAS Range-Extender Innovations as of May 2010

University	-
FOM	-
STW	-
NWO Other	100%
Industry	-
TNO	-
GTI	-
EU	-
Scholarships	-

**START OF THE PROJECT**  
2008

**INFORMATION**

MFM Speetjens  
040 247 5428  
m.f.m.speetjens@tue.nl  
www.energy.tue.nl



**PROJECT LEADERS**

MFM Speetjens, AA van Steenhoven

**RESEARCH THEME**

Complex structures of fluids

**PARTICIPANTS**

Z Liu, PR Bloemen

**COOPERATIONS**

HJH Clercx & GJF van Heijst, Dept. Applied Physics, TU/e, VV Meleshko, Kiev National Taras Shevchenko University, Ukraine, G Metcalfe, CSIRO-MMT, Melbourne, Australia, A Reusken, Dept. Mathematics, RWTH, Aachen, Germany

**FUNDED**

TU/e-W	
University	100%
FOM	-
STW	-
NWO Other	-
Industry	-
TNO	-
GTI	-
EU	-
Scholarships	-

**START OF THE PROJECT**

2007

**INFORMATION**

MFM Speetjens  
040 247 5428  
m.f.m.speetjens@tue.nl  
www.energy.tue.nl

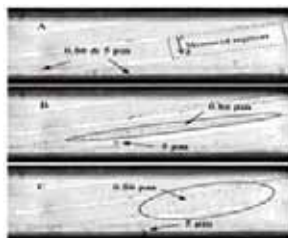
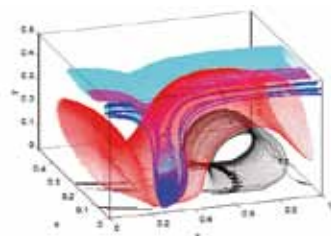
**PROJECT AIM**

The heat transfer in (laminar) micro-flows depends essentially on the topology of the Lagrangian fluid paths. Aim of the study is to investigate the fundamental connection between heat transfer and flow topology and to explore its potential with regard to control and optimisation of heat transfer in micro-flows.

**PROGRESS**

Further numerical studies have been performed on manipulation of the flow topology by way of AC electro-osmosis (ACEO), possibly in combination with other forcing mechanisms (left figure). This exposed a wide variety of flow topologies and transport properties that may have great potential for application in micro-flows. Moreover, further experimental studies on practical applications of ACEO micro-flows – and their particular transport properties – are in progress. Present efforts concentrate on particle separation (right figure) and mixing within bubbles.

**DISSERTATIONS**

-

**SCIENTIFIC PUBLICATIONS**

1. D.J.H.N. van der Donk, A.J.H. Frijns, Z. Liu, R.J.S. Derks, A.H. Dietzel, Experimental validation of a novel particle separation mechanism using AC electroosmosis, in Proceedings of the 2nd European Conference on Microfluidics; Editors: Stéphane Colin and Gian Luca Morini, Toulouse, France, uFLU10-74, (2010).
2. Z. Pouransari, M.F.M. Speetjens, H.J.H. Clercx, Formation of coherent structures by fluid inertia in three-dimensional laminar flows, *J. Fluid Mech.*, 654(-), 5-33, (2010).
3. M.F.M. Speetjens, A.A. van Steenhoven, Visualisation of heat transfer in 3D unsteady flows, *Int. J. Thermal Sci.*, 49(7), 1103-1114, (2010).
4. M.F.M. Speetjens, Chaotic mixing: a sure way for optimal thermal conditions?, in Proceedings of IHTC14 2010 ASME International Heat Transfer Conference; Editors: -, Washington DC, United States.
5. M.F.M. Speetjens, The effect of chaotic mixing on heat transfer in continuous thermal processes at low Peclet numbers, in Proceedings of ICNMM2010 2010 ASME International Conference on Nanochannels, Microchannels, and Minichannels; Editors: S. Kandlikar, M. King, Montreal, Canada.
6. M.F.M. Speetjens, A.A. van Steenhoven, Heat and mass transfer made visible, in 6th International Conference on Diffusion in Solids and Liquids: Mass Transfer, Heat Transfer and Microstructure and Properties, ; Editors: A. Oechsner, G.E. Murch, Paris, France.
7. M.F.M. Speetjens, Chaotic mixing: a sure way for efficient heat transfer?., in Fifth International Conference on Thermal Engineering: Theory and Applications May 10-14, 2010; Editors: M. Hasnaoui & M.Z. Saghir, Marrakesh, Morocco.

Transport in ACEO micro-flows. Panel (a): complex flow topology created by combination of ACEO and axial pressure gradient. Panel (b): particle separation. Large particles continue with the pressure-driven main horizontal flow; small particles are deflected by the ACEO flow set up by the inclined electrodes.

**PROJECT AIM**

There is a tendency that mechanical and electrical component become smaller and smaller. Since most components produce heat when operating, local, enhanced microchannel cooling becomes essential in order to ensure its performance and to ensure the life span of such a micro-component. Macroscopic models for heat transfer are not sufficient to describe the cooling mechanisms on this scale anymore. Therefore particle-based models have to be used. The goal of this project is to study the convective heat transfer and evaporative cooling in micro-devices by Molecular Dynamics (MD) and Direct Simulation Monte Carlo (DSMC) techniques and to develop a multi-scale simulation method.

**PROGRESS**

Firstly, evaporative cooling in microchannels was studied. Special attention was given to the gas-liquid-solid interface, since in that region locally the heat transfer is enhanced. Since on these small scales the boundary and interface conditions are very important for the overall performance of the device, we choose the approach in which we started with modelling and understanding the essential physical phenomena at a molecular level. The enhanced heat transfer, modeled by our MD code, was compared to the results obtained by the continuum microregion model developed by P. Stephan et al. (IJHMT 35:383-391, 1992). They showed good agreement, but the evaporative resistance at the liquid-vapor interface was under predicted by the continuum model. Furthermore, the model was extended to able to model more complex 3D-geometries: radial and functional implicit boundary condition have been implemented on our MD simulation code. The method has been used to study the effect of different geometries and for different Knudsen number s on the gas flow in micro- nanochannels.

**DISSERTATIONS**

1. E.A.T.van den Akker, Particle-based evaporation models and wall interaction for microchannel cooling, PhD. Thesis, 2010, Eindhoven University of Technology  
Advisors: A.A. van Steenhoven, P.A.J. Hilbers; Co-advisor: A.J.H. Frijns.

**SCIENTIFIC PUBLICATIONS**

1. E.A.T. van den Akker, A.J.H. Frijns, P.A.J. Hilbers, P. Stephan, A.A. van Steenhoven, Molecular Simulation of the Microregion, in 2nd International GASMEMS Workshop; Editor: A.J.H. Frijns, Les Embiez, France, CD, (2010).
2. A.J.H. Frijns, E.A.T. van den Akker, P.A.J. Hilbers, P. Stephan, A.A. van Steenhoven, Evaporative microchannel cooling: an atomistic approach, in: Proceedings of the 14th International Heat Transfer Conference (IHTC14); Washington, DC, United States, IHTC14-22839, (2010).
3. J.Kim, A.J.H. Frijns, A.A. van Steenhoven, Development of a Molecular Dynamics Simulation Model for Heat Transfer in Vapors, in 2nd International GASMEMS Workshop; Editor: A.J.H. Frijns, Les Embiez, France, CD, (2010).

**PROJECTLEADERS**

AJH Frijns, AA van Steenhoven

**RESEARCHTHEME**

Mathematical and computational methods for fluid flow analysis

**PARTICIPANTS**

EAT van den Akker, JH Kim

**COOPERATIONS**

PAJ Hilbers, AJ Markvoort, Biomedical Engineering, TU/e, A Frezotti, Milan

**FUNDED**

MicroNed, GASMEMS (Marie-Curie, FP7)

University	25%
FOM	-
STW	-
NWO Other	-
Industry	25%
TNO	-
GTI	-
EU	50%
Scholarships	-

**START OF THE PROJECT**

2002, 2009

**INFORMATION**

AJH Frijns  
040 247 4825  
a.j.h.frijns@tue.nl  
www.energy.tue.nl

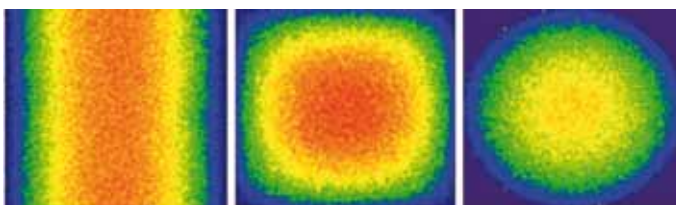

Velocity fields for a nano-slit and for nanochannels with rectangular and circular cross-sections

**PROJECT LEADERS**

SV Nedeaa, AA van Steenhoven

**RESEARCH THEME**

Mathematical and computational methods for fluid flow analysis

**PARTICIPANTS**

EJ Arlemark, A Frijns

**COOPERATIONS**GASMEMS ([www.gesmems.eu](http://www.gesmems.eu))AOES (<http://www.aoes.com>)INFICON (<http://www.inficon.com>)**FUNDED**

Seventh Framework Programme (ITN-FP7/2007-2013) grant agreement n° 215504

University	-
FOM	-
STW	-
NWO Other	-
Industry	-
TNO	-
GTI	-
EU	100%
Scholarships	-

**START OF THE PROJECT**

2010

**INFORMATION**

SV Nedeaa

040 247 5410

[s.v.nedeaa@tue.nl](mailto:s.v.nedeaa@tue.nl)[www.energy.tue.nl](http://www.energy.tue.nl)**PROJECT AIM**

As predictions of out-gassing processes and cooling of computer circuits are becoming more important, modeling of gas interactions with surfaces is a topic gaining increasing interest among researchers. The main aim of this appointment is to derive a technique which can qualitatively simulate multi-scale gas flow behavior, with emphasis on heat transfer for dense or dilute gases. In order to simulate such cases a hybrid method will be implemented in the toolkit OpenFOAM. The hybrid method will involve molecular dynamics (MD) and direct simulation Monte Carlo, producing the solution of the Enskog equation (DSMC-ensk). Hybrid methods are promising for solving multi-scale gas flows since the most detailed gas/surface interactions can be captured by the precise MD method while the DSMC-ensk method provides a more cost efficient description of the bulk gas.

**PROGRESS**

The first task of the project aim has been completed by making the necessary modifications of the conventional DSMC method needed to simulate denser gases. This has been achieved by allowing DSMC-ensk to produce the solution of the Enskog equation incorporating consideration of the spatial finite extent of molecules, as opposed to DSMC producing the solution of the Boltzmann equation, where molecular collisions has a local character. Preliminary knowledge of various molecular descriptions has been gathered for the two techniques involved in the hybrid method i.e. MD using soft-spheres and DSMC-ensk using hard-spheres. This comprises an important step within the project aim since both techniques are required to produce similar results for cases where they both are considered applicable. Also, preliminary investigation is being performed concerning how to modify the DSMC-ensk particles in order to achieve post-collision velocities which are more correlated to the velocities obtained from MD.

**DISSERTATIONS**

-

**SCIENTIFIC PUBLICATIONS**

1. E.J. Arlemark, S. Kokou Dadzie, J. M. Reese, An Extension to the Navier-Stokes-Equations to Incorporate Gas Molecular Collisions With Boundaries, 041006-8. *Journal of Heat Transfer* 132 (4) (2010).
2. P. Spijker, A.J. Markvoort, S.V. Gaastra - Nedeaa, P.A.J. Hilbers, Computation of accommodation coefficients and the use of velocity correlation profiles in molecular dynamics simulations, *Phys. Rev. E*, 81, 011203, (2010).

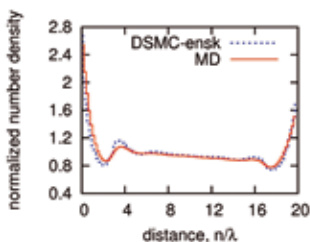
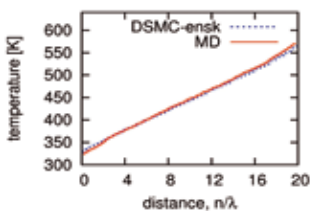

MD and DSMC-ensk simulation techniques are used to obtain the shown molecular number density profiles and temperature profiles of a quiescent dense gas confined between two parallel planar walls which are 20 mean free paths apart. The left wall set to a temperature of 300 Kelvin and the right wall is set to 600 Kelvin.

# MOLECULAR DYNAMICS TO ENHANCE EFFICIENT COMPACT HEAT STORAGE

## PROJECT AIM

This study focuses on the dynamics of hydration and dehydration reactions of salt hydrates ( $MgSO_4 \cdot 7H_2O$ ,  $MgCl_2 \cdot xH_2O$  etc) from a molecular point of view. The project aims to identify the molecular and structural parameters which limits the kinetics and usability of salt hydrates as thermochemical heat storage materials. This study will help to classify such materials based on the storage efficiency, usability, kinetics, reusability etc. This information can be used to identify the best suitable material for thermochemical heat storage.

## PROGRESS

Reactive force field method (ReaxFF) has been validated as a satisfactory tool to simulate reactive molecular systems. The viability of the method to model condensation of water vapor during cooling has been verified. The radial distribution functions of water has been computed using ReaxFF molecular dynamics method and satisfactory agreement is found with the accepted literature values. Also changes in internal energy computed for water between different thermodynamic states shows satisfactory agreement with steam tables. The ability of ReaxFF to model chemical reactions has been tested by successfully modeling Carbon-oxidation reaction. DFT (density functional theory) calculations are being done to optimize the force field to model hydration and dehydration reactions of  $MgSO_4$ . Once a good force field is obtained, hydration and dehydration reactions can be modelled using ReaxFF-molecular dynamics method.

## DISSERTATIONS

-

## SCIENTIFIC PUBLICATIONS

-

## PROJECT LEADERS

SV Nedea, CCM Rindt,  
AA van Steenhoven

## RESEARCH THEME

Mathematical and computational  
methods for fluid flow analysis

## PARTICIPANTS

E lype

## COOPERATIONS

A van Duin, (Associate Professor,  
Mechanical and Nuclear  
Engineering, Penn State University.)  
HA Zondag (ECN)

## FUNDED

European Graduate School

University 100%

FOM -

STW -

NWO Other -

Industry -

TNO -

GTI -

EU -

Scholarships -

## START OF THE PROJECT

2009

## INFORMATION

SV Nedea

040 247 5410

s.v.nedea@tue.nl

www.energy.tue.nl

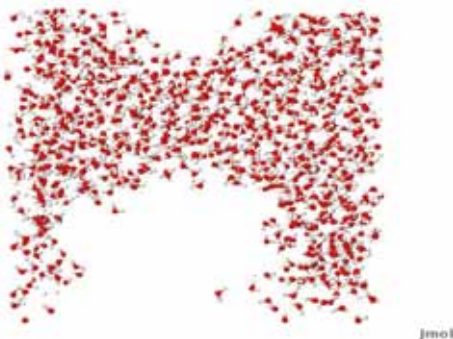

Molecular dynamic simulation of water

**PROJECT LEADERS**

CCM Rindt, AA van Steenhoven,  
HA Zondag

**RESEARCH THEME**

Mathematical and computational  
methods for fluid flow analysis

**PARTICIPANTS**

K Ermakov, C Ferchaud (ECN)

**COOPERATIONS**

Energy research Centre of the  
Netherlands (ECN)

**FUNDED**

ADEM	
University	-
FOM	-
STW	-
NWO Other	-
Industry	-
TNO	-
GTI	100%
EU	-
Scholarships	-

**START OF THE PROJECT**

2010

**INFORMATION**

CCM Rindt  
040 247 2978  
c.c.m.rindt@tue.nl  
www.energy.tue.nl

**PROJECT AIM**

A promising concept for seasonal heat storage in the built environment is based on the reversible sorption process of water vapor. Therefore experimentally validated micro- and meso-scale models are developed for the hydration and dehydration processes taking place in powdery samples of crystalline salt hydrates. The processes are a combination of heat and vapor transport in the crystalline matrix structure of the grains taking into account the presence of fractures/dislocations and cracks, and in the pore structure of the powdery samples (in between the grains).

**PROGRESS**

- Literature survey on the project background, theoretical aspects of the hydration and dehydration processes and current research status was carried out.
- Mathematical models for the hydration/dehydration processes within the grains were investigated.
- Existing mathematical models for the mass and heat transfer in between the grains were analyzed.
- A number of methods for the flow in between the grains was investigated: Fictitious domain methods and Lattice-Boltzmann method.
- A report was written containing the theoretical information, description of the project and different methods together with their advantages and disadvantages in connection with the project.

**DISSERTATIONS**

-

**SCIENTIFIC PUBLICATIONS**

1. R. Santbergen, C.C.M. Rindt, H.A. Zondag, R.J.C.. van Zolingen, Detailed analysis of the energy yield of systems with covered sheet-and-tube PVT collectors, *Solar Energy*, 84, 867-878, (2010).
2. R. Santbergen, J.M. Goud, M. Zeman, J.A.M. van Roosmalen, R.J.C.. van Zolingen, The AM 1.5 Absorption factor of thin-film solar cells, *Solar Energy Mater. Solar Cells*, 94, 715-723, (2010).

Hydration/dehydration processes within the grains

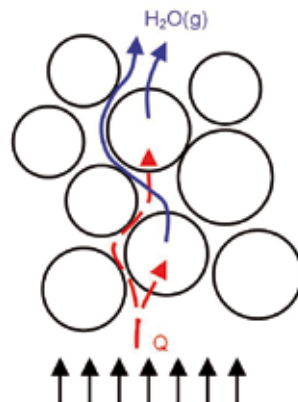

**PROJECT AIM**

The aim of the project is to enhance the selectivity of gas-sensors by covering it with a window. Ideally this window will only transmit the targeted gas molecules and obstruct all other particles. In a first approach, passive polymer membranes will be used. Finally, an active system will be designed and tested to actively sample and operate at non-equilibrium to further enhance the selectivity and response-time of the sensor.

**PROGRESS**

A literature study has been done looking at perm-selective membranes, gas sensor principles, gas permeation and membrane fabrication. A setup has been designed and built to characterize the permeation of different gasses through different membranes. Simulations have been performed to predict typical experiments that will be done using this setup.

**DISSERTATIONS**

-

**SCIENTIFIC PUBLICATIONS**

1. R.J.S. Derks, A.J.H. Frijns, M.W.J. Prins, A.H. Dietzel, Multibody interactions of actuated magnetic particles used as fluid drivers in microchannels, *Microfluidics and nanofluidics*, 9, 357-364, (2010).
2. M. Matteucci, F.G.A. Homburg, S. van Pelt, A.H. Dietzel, A reconfigurable superparamagnetic bead filter for microfluidic detection of bio-material, *Microelectronic Engineering*, 8(5-8), 5, (2010).
3. S. van Pelt, R. Derks, M. Matteucci, M. Fougat Hansen and A.H. Dietzel, Flow-orthogonal bead oscillation in a microfluidic chip with a magnetic anisotropic flux-guide array, *Biomedical Microdevices*, DOI 10.1007/s10544-010-9503-5, (2010).

**PROJECTLEADERS**

AH Dietzel, AJH Frijns

**RESEARCHTHEME**

Complex structures of fluids

**PARTICIPANTS**

S van Pelt

**COOPERATIONS**

NXP, DSM, Holst Center

**FUNDED**

CATRENE / PASTEUR

University -

FOM -

STW -

NWO Other -

Industry -

TNO -

GTI -

EU 100%

Scholarships -

**START OF THE PROJECT**

2009

**INFORMATION**

AH Dietzel

040 2475235

a.h.dietzel@tue.nl

www.energy.tue.nl

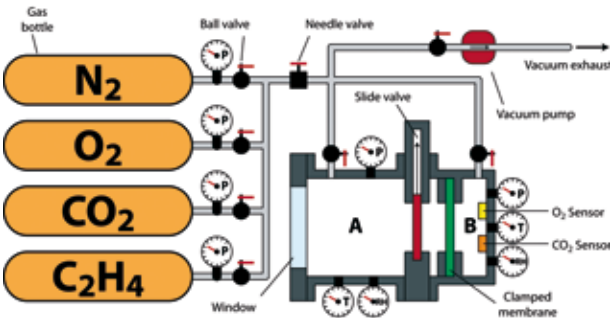

Experimental set-up

**PROJECT LEADERS**

Y Bellouard, AH Dietzel

**RESEARCH THEME**

Complex structures of fluids

**PARTICIPANTS**

A Schaap

**COOPERATIONS**

Norwegian Water Research Institute  
(providing specimens)

**FUNDED**

Eindhoven University of Technology

University      100%

FOM              -

STW              -

NWO Other      -

Industry        -

TNO              -

GTI              -

EU                -

Scholarships   -

**START OF THE PROJECT**

2010

**INFORMATION**

AH Dietzel

040 2475235

a.h.dietzel@tue.nl

www.energy.tue.nl

**PROJECT AIM**

The identification of algae species is useful and important for monitoring water quality and conditions for health and environmental applications. This project aims to develop a chip-based approach to identifying and classifying algae species in water in real-time, using microfluidics with integrated optical and/or other sensors. We use a femtosecond laser to create arbitrarily shaped microchannels and optical waveguides in fused silica, which allows optofluidic integration on a single substrate.

**PROGRESS**

A new PhD student joined the group to work on this new project in November of last year; progress to date has focussed on the analysis of data from a previous prototype and on the design of an improved system.

**DISSERTATIONS**

-

**SCIENTIFIC PUBLICATIONS**

1. D. Tiwari, Y.J. Bellouard, A.H. Dietzel, M. Ren, E. Rubingh, E. Meinders, Dynamical Observation of Femtosecond-Laser-Induced Bubbles in Water Using a Single Laser Source for Probing and Sensing. Applied Physics Express, 3(-), 127101, (2010).

## REDUCTION OF GAS COOLER FOULING IN BIOMASS GASIFIERS

### PROJECT AIM

Fouling of heat exchange equipment used for the recovery of waste heat is an important constraint with respect to the use of such equipment. Because of fouling, the efficiency of such apparatus drops. In the worst case, fouling leads to total failure of the heat exchanger with enormous economical consequences. In this project, numerical and experimental approaches are implemented to investigate the factors governing particulate fouling.

### PROGRESS

Fouling is defined as the accumulation of particles on a heat exchanger surface forming a layer of very low thermal conductivity which causes maintenance problems leading to economic losses. As observed in large-scale biomass gasifiers, the character of the fouling layer is related to the local gas temperature, velocity and condensable species present in the gas. Controlled dry particulate fouling experiments have been carried out to investigate the factors that affect fouling like: gas phase velocity, particle type, particle size, concentration, condensation and gas phase temperature. The experiments are carried out in a specially designed high-temperature, up to 500 degrees Celsius, test-rig. Results indicate that the gas phase velocity has a strong influence on the deposition rates and beyond a certain critical flow velocity, deposition ceases. Along with the controlled fouling experiments, experiments for particle impaction over a liquid coated substrate have been carried out to determine the sticking and removal behavior in the presence of a thin liquid film. The results will be used to develop particle sticking as input to CFD-codes.

### DISSERTATIONS

-

### SCIENTIFIC PUBLICATIONS

1. M.S. Abd-Elhady, S. Abd-Elhady, C.C.M. Rindt, A.A. van Steenhoven, Force propagation speed in a bed of particles due to an incident particle impact, *Advanced Powder Technology*, 21(2), 150-164, (2010).

### PROJECTLEADERS

CCM Rindt, AA van Steenhoven

### RESEARCHTHEME

Mathematical and computational methods for fluid flow analysis

### PARTICIPANTS

KK Sathyanarayananrao Subbarao,  
PR Bloemen

### COOPERATIONS

L Rabou, ECN Petten

### FUNDED

Agentschap NL	
University	-
FOM	-
STW	-
NWO Other	-
Industry	-
TNO	-
GTI	100%
EU	-
Scholarships	-

### START OF THE PROJECT

2007

### INFORMATION

CCM Rindt  
040 247 2978  
c.c.m.rindt@tue.nl  
www.energy.tue.nl

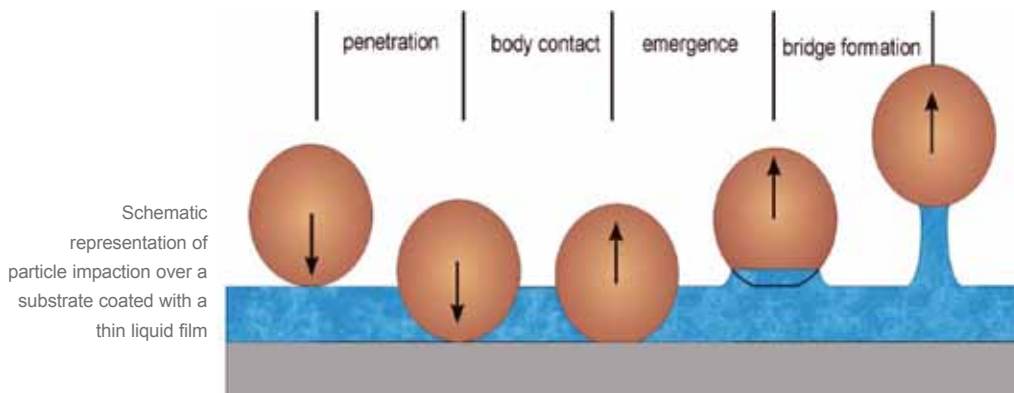



## PROJECT LEADERS

AJH Frijns, AA van Steenhoven

## RESEARCH THEME

Mathematical and computational methods for fluid flow analysis

## PARTICIPANTS

BRM Kingma, WD van MarkenLichtenbelt

## COOPERATIONS

University of Maastricht, University Hospital Maastricht, TU/e, Dept. of Architecture, Building and Planning

## FUNDED

AgentschapNL	
University	-
FOM	-
STW	-
NWO Other	-
Industry	100%
TNO	-
GTI	-
EU	-
Scholarships	-

## START OF THE PROJECT

1999

## INFORMATION

AJH Frijns,  
040 247 4825  
a.j.h.frijns@tue.nl  
www.energy.tue.nl

## PROJECT AIM

The goal of this project is to develop dynamic and human specific thermo-physiological model to predict the heat transfer and temperature distribution in the human body. The model will be used for medical applications and for the prediction of thermal comfort in the built environment.

## PROGRESS

Our thermo-physiological model ThermoSEM is further improved by the introduction of a neurological based thermoregulation model. The new model outcomes are compared with experiments on volunteers. Good agreement is shown for blood flow, and for skin and core temperatures for young adults as well as for elderly. This thermo-physiological model will also be used to predict the thermal responses to (changes in) the indoor climate. It will be extended such that, from the skin temperatures and core temperatures, the thermal sensation can be predicted. This will be used to achieve energy savings in housings while ensuring thermal comfort for the occupants.

Furthermore, the model is extended with a cardio-vascular module such that blood pressure can be predicted as well. It is successfully applied to model blood pressure changes during haemodialysis.

## DISSERTATIONS

-

## SCIENTIFIC PUBLICATIONS

1. B.R.M. Kingma, A.J.H. Frijns, W.H.M. Saris, A.A. van Steenhoven, W. van Marken Lichtenbelt, Cold induced vasoconstriction at forearm and hand skin sites: the effect of age, *Eur J Appl Physiol*, 109(5), 915-921, (2010).
2. B.R.M. Kingma, W.H.M. Saris, A.J.H. Frijns, A.A. van Steenhoven, W.D. van Marken Lichtenbelt, Modeling skin blood flow: a neuro-physiological approach, in *Proceedings of the International Conference on Fuzzy Computation and 2nd International Conference on Neural Computation*; Valencia, Spain, 156-162, (2010).
3. D. Fiala, A. Psikuta, G. Jendritzky, S. Paulke, D.A.. Nelson, W. van Marken Lichtenbelt, A.J.H. Frijns, Physiological modeling for technical, clinical and research applications, *Front Biosci*, S2, 939-968, (2010).
4. N.M.W. Severens, W. van Marken Lichtenbelt, A.J.H. Frijns, B.R.M. Kingma, B.A.J.M. de Mol, A.A. van Steenhoven, Measurement of model coefficients of skin sympathetic vasoconstriction, *Physiol. Meas.*, 31, 77-93, (2010).
5. N.M.W. Severens, W. van Marken Lichtenbelt, A.J.H. Frijns, A. van Ooij, M.A.E. Marcus, B.A.J.M. de Mol, A.A. van Steenhoven, Temperature and surgical wound heat loss during orthopaedic surgery: computer simulations and measurements, *Can. J. Anesthesia*, 57(4), 381-382, (2010).

Bio-neural model for predicting heat transfer and characteristic result

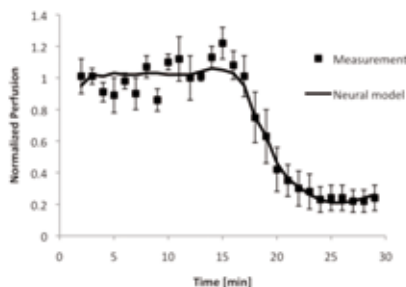
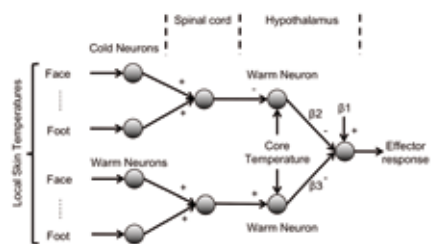



## CENTRE FOR ANALYSIS, SCIENTIFIC COMPUTING AND APPLICATIONS (CASA)



Prof.dr. RMM Mattheij

The Centre for Analysis, Scientific Computing and Applications (CASA) combines all activities related to analysis at the Department of Mathematics and Computer Science of Eindhoven University of Technology. Its major research objective is to develop new and improve existing mathematical (both analytical and numerical) methods for a wide range of applications in science and engineering. More specifically, the research aims at developing and integrating methods and ideas from mathematical modelling, analysis of partial differential equations and scientific computing. This area of research is commonly known as Computational Science and Engineering (CSE). This is reflected by extensive collaboration with researchers in the technical sciences.

Also contact and cooperation with industrial partners is vital. The chairs participating in CASA are Applied Analysis, Variational Methods and Scientific Computing. Within CASA the research related to fluid dynamics deals with aero-acoustics, porous media, viscous and viscoelastic equations and CFD.

### PROJECT AIM

- Hydro-acoustic instabilities in sheared flows.
- Boundary condition for mean flow profiles with vanishing boundary layer thickness.
- The critical layer in shear flows.

### PROGRESS

Instability analysis of an incompressible flow with a linear velocity profile. An enhanced Ingard-Myers type boundary condition for a mean flow with vanishing boundary layer thickness. An analytical formula for the critical thickness in an incompressible linear setup, where the flow becomes absolutely unstable.

### DISSERTATIONS

-

### SCIENTIFIC PUBLICATIONS

1. Rienstra, S.W., Darau, M. (2010). Mean flow boundary layer effects of hydrodynamic instability of impedance wall. In R.J. Astley, G. Gabard (Eds.), IUTAM Symposium on Computational Aero-Acoustics for Aircraft Noise Prediction (Southampton, UK, March 29-31, 2010). (Procedia Engineering, Vol. 6, pp. 124-132).
2. Brussee, R., Darau, M., Dworzynska, M., Fan, Y., Koeleman, P., Kowalczyk, P., Samson, J., Schlömer, N., Swist, T., Wijk, A.C.C. van (2010). Indoor navigation in peer to peer networks. Proceedings of the 5th ESA Workshop on Satellite Navigation Technologies. Noordwijk: ESTEC.
3. Brussee, R., Darau, M., Dworzynska, M., Fan, Y., Koeleman, P., Kowalczyk, P., Schlömer, N., Swist, T., Wijk, A.C.C. van (2010). Position estimating in peer-to-peer networks. Proceedings of the 72nd European Study Group Mathematics with Industry (SWI 2010, Amsterdam, The Netherlands, January 25-29, 2010). (pp. 10-24). Amsterdam: CWI.

### PROJECT LEADERS

S Rienstra, B Mattheij, S Balint

### RESEARCH THEME

Mathematical and computational methods for fluid flow analysis

### PARTICIPANTS

M Darau

### COOPERATIONS

West University of Timisoara, Romania, University of Cambridge, DAMTP

### FUNDED

TUE	
University	100%
FOM	-
STW	-
NWO Other	-
Industry	-
TNO	-
GTI	-
EU	-
Scholarships	-

### START OF THE PROJECT

2008

### INFORMATION

S Rienstra

040 247 4603

s.w.rienstra@tue.nl

**PROJECT LEADERS**

RMM Matheij

**RESEARCH THEME**

Mathematical and computational methods for fluid flow analysis

**PARTICIPANTS**

MA Etaati, AS Tijsseling

**COOPERATIONS**

Prof.dr. ATAM de Waele

**FUNDED**

STW

University -

FOM -

STW 100%

NWO Other -

Industry -

TNO -

GTI -

EU -

Scholarships -

**START OF THE PROJECT**

2005

**INFORMATION**

MA Etaati

06 1900 4022

m.a.etaati@tue.nl

**PROJECT AIM**

The project concerns pulse-tube refrigerators of the Stirling type for the important temperature region of 4 Kelvin and below. The system that we propose will operate at frequencies which are an order of magnitude higher and pressure amplitudes which are an order of magnitude lower than usual. A numerical model describing oscillating Helium flow in multi-stage coolers has been developed. The main goals in this project include numerical analysis of the fluid flow in the system as well as optimization in terms of geometry of single-stage and three-stage PTRs.

**PROGRESS**

The governing equations are conservation laws including the full Navier-Stokes equations. A one-dimensional model of a three-stage PTR both for tubes and regenerators has been developed. In this model the Van der Waals equation of state is used for the real gas. All material properties of the gas and the regenerator solids are considered to be temperature dependent. In the simulation six orifice settings are to be adjusted to reach the lowest possible temperature. This temperature occurs when the cooling power at the third stage becomes zero. We first validated our simulation against experimental work done at the Low Temperature Group of the Applied Physics Department of TU/e on a PTR operating at low frequency. In the second step a high-frequency three-stage PTR was simulated and analyzed. The developed software is intended to become a design tool for cryogenic engineers.

**DISSERTATIONS**

-

**SCIENTIFIC PUBLICATIONS**

-

**PROJECT AIM**

Numerical simulation and shape optimisation of blow moulding processes.

**PROGRESS**

A 2D axial-symmetrical blow moulding simulation model has been developed. This model simulates the blow stage of manufacturing hollow containers, e.g. bottles or jars. In a blow stage a preform is brought into a mould and subsequently blown into a mould shape. The simulation model is based on level set methods. Applications presented are glass blowing and PET stretch blow moulding. The inverse problem for glass blowing is to determine an optimal preform from the desired container shape. The solvability and sensitivity of the inverse problem are analysed. Numerical shape optimization is used to find a solution to the inverse problem. The method describes the glass-air interfaces of the preform by parametric curves, e.g. splines, Bezier curves, and finds the optimal positions of the control points of the curves.

**DISSERTATIONS**

-

**SCIENTIFIC PUBLICATIONS**

1. Groot, J. A. W. M., Giannopapa, C. G., and Mattheij, R. M. M. A computer simulation model for the stretch blow moulding process of polymer containers. In Proceedings of the ASME 2010 Pressure Vessels & Piping Division / K-PVP Conference (July 18-22, 2010).
2. Groot, J. A. W. M., Mattheij, R. M. M., and Giannopapa, C. G. Modelling preform and mould shapes in blow moulding (submitted/under review). In Proceedings 16th European Conference on Mathematics for Industry (July 26-30, 2010).

**PROJECTLEADERS**

RMM Mattheij, CG Giannopapa

**RESEARCHTHEME**

Mathematical and computational methods for fluid flow analysis

**PARTICIPANTS**

-

**COOPERATIONS**

-

**FUNDED**

TUE	
University	100%
FOM	-
STW	-
NWO Other	-
Industry	-
TNO	-
GTI	-
EU	-
Scholarships	-

**START OF THE PROJECT**

2007

**INFORMATION**

JAWM Groot  
040 247 5546  
j.a.w.m.groot@tue.nl

**PROJECT LEADERS**

RMM Mattheij, AS Tijsseling

**RESEARCH THEME**

Mathematical and computational methods for fluid flow analysis

**PARTICIPANTS**

Qingzhi Hou

**COOPERATIONS**

University of Nottingham

**FUNDED**

The Chinese Ministry of Education

University -

FOM -

STW -

NWO Other -

Industry -

TNO -

GTI -

EU -

Scholarships 100%

**START OF THE PROJECT**

2008

**INFORMATION**

Qingzhi Hou

040 247 5546

q.hou@tue.nl

**PROJECT AIM**

Smoothed Particle Hydrodynamics (SPH) numerical techniques are used to model the important problem of liquid slugs moving at high speeds in pipelines. The impact of such slugs at pipe bends, pumps and valves may cause great material damage. Fluid-structure interaction is taken into account to accurately estimate the impact forces. Slug flow, waterhammer and column separation are the phenomena dealt with. Experimental data obtained for the controlled filling and emptying of a large-scale pipe are used for validation.

**PROGRESS**

A series of laboratory experiments on the controlled filling and emptying of pipelines, and on unsteady friction, has been carried out at Deltares, Delft, within the framework of the European Hydralab III project. The experimental data have been analysed and a test report written. The SPH method has been explored and applied to a set of one- and two-dimensional test problems including waterhammer, column separation and heat conduction. Several corrections to SPH have been investigated and tested.

**DISSERTATIONS**

-

**SCIENTIFIC PUBLICATIONS**

1. Bergant A., van 't Westende J.M.C., Koppel T., Gale J., Hou Q., Pandula Z. & Tijsseling A.S. 2010 Water hammer and column separation due to accidental simultaneous closure of control valves in a large scale two-phase flow experimental test rig. Proc. of the 2010 ASME Pressure Vessels and Piping Division Conf., Bellevue, Washington, USA, July 2010, Paper PVP2010-26131.
2. Tijsseling A.S., Hou Q., Svingen B. & Bergant A. 2010 Acoustic resonance in a reservoir-pipeline-orifice system. Proc. of the 2010 ASME Pressure Vessels and Piping Division Conf., Bellevue, Washington, USA, July 2010, Paper PVP2010-25083.
3. Hou Q.Z., Tijsseling A.S. & Mattheij R.M.M. 2010 An improvement for singularity in 2-D corrective smoothed particle method with application to Poisson problem. Proc. of the 16th ECMI Conf., ECMI 2010 (Editor M. Günther), Wuppertal, Germany, July 2010.

# SOUND PROPAGATION IN A DUCT WITH SHEARED FLOW AND NON-LOCALLY REACTING LINERS

## PROJECT AIM

The goal of the project is to further develop and make available a class of semi-analytical solutions (based on modes) for the propagation and attenuation of sound in flow ducts, aiming in particular to the reduction of noise from the auxiliary power unit (APU, a turbine engine) of aircraft. Here, the walls of the duct are covered with acoustically damping material, i.c. non-locally reacting liners (e.g. metallic foam). Furthermore, the mean flow exhibits strong shear and temperature gradients. Keywords: duct acoustics, aeroacoustics.

## PROGRESS

A new code based on numerical continuation has been developed. This code is capable of handling non-uniform mean flow, non-uniform temperature and locally reacting impedance walls. The numerical results have been compared to results from other existing codes. Furthermore, analytical WKB-type solutions have been used in combination with this code to compute sound propagation in a duct which has an impedance that varies slowly in the axial direction. These numerical results have been compared to the numerical results of an approach where the duct is subdivided in different segments which have constant impedance.

## DISSERTATIONS

-

## SCIENTIFIC PUBLICATIONS

-

## PROJECT LEADERS

RMM Mattheij, P Sijtsma,  
SW Rienstra

## RESEARCH THEME

Mathematical and computational  
methods for fluid flow analysis

## PARTICIPANTS

P Sijtsma (supervisor NLR), SW  
Rienstra (supervisor), RMM Mattheij  
(promotor), M Oppeneer (PhD-  
student)

## COOPERATIONS

Airbus

## FUNDED

National Aerospace Laboratory NLR  
University -  
FOM -  
STW -  
NWO Other -  
Industry -  
TNO -  
GTI 100%  
EU -  
Scholarships -

## START OF THE PROJECT

2009

## INFORMATION

P Sijtsma  
0527 248661  
sijtsma@nlr.nl



**PROJECT LEADERS**

RMM Matheij, J Dam, JHM ten Thije Boonkkamp

**RESEARCH THEME**

Mathematical and computational methods for fluid flow analysis

**PARTICIPANTS**

PI Rosen Esquivel

**COOPERATIONS**

-

**FUNDED**

Ballast Nedam  
 University -  
 FOM -  
 STW -  
 NWO Other -  
 Industry 100%  
 TNO -  
 GTI -  
 EU -  
 Scholarships -

**START OF THE PROJECT**

2008

**INFORMATION**

PI Rosen Esquivel  
 040 247 3162  
 p.i.rosenesquivel@tue.nl

**PROJECT AIM**

Development of techniques for the construction of lower dimensional models (nodal, or 1D models) and/or efficient CFD methods, for simulating flow transport in components of the cryogenic industry. The models should be adequate for their use in the simulation of a network of interconnected process components, and for optimization purposes. The main effects to be captured are those generated by wall-shape, some other possible factors to study are: wall heat transfer, natural convection, turbulence, transitional flow and phase-transition.

**PROGRESS**

The case of laminar flow in axially symmetric pipes has been treated in analytically and numerically. By combining an analytical formula for the friction factor with the method of slow variations, we were able to develop approximate expressions for the friction factor. These expressions appear in terms of one dimensional integrals, which are extremely fast to compute, when compared to traditional CFD methods. The method has been validated and published in a conference paper. The numerical alternative is based on a FEM model for the problem of periodic corrugated pipes. This model has been validated and put into use for studying the problem of wall-shape optimization. The results of this research are currently under preparation for their publication.

**DISSERTATIONS**

-

**SCIENTIFIC PUBLICATIONS**

1. P.I. Rosen Esquivel, J.H.M ten Thije Boonkkamp, J.A.M. Dam, R.M.M. Matheij. "Efficient estimation of the friction factor for forced laminar flow in axially symmetric corrugated pipes". Proceedings of ASME 2010 3rd Joint US-European Fluids Engineering Summer Meeting, Montreal Canada.

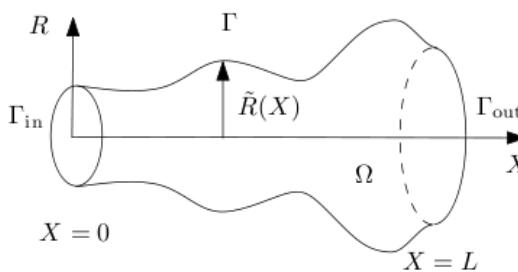

**FIGURE 1.** Axisymmetric pipe with center line along the  $X$ -axis.  $\Gamma$  stands for the wall of the pipe,  $\Gamma_{in}$  for the cross section at  $X = 0$  and  $\Gamma_{out}$  the cross section at  $X = L$

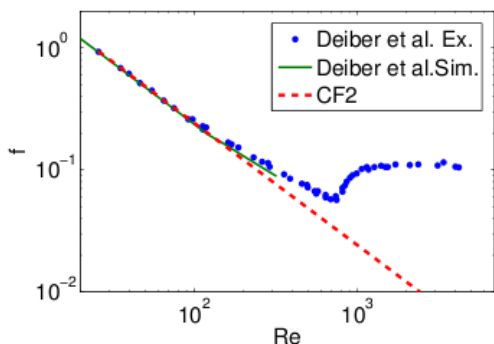

**FIGURE 4.** Experimental results (blue dots), 2D numerical solution (solid green line) for the friction factor by Deiber et al. [14, p. 642], and approximation obtained with correction factor  $CF2$  (41) (dashed line)





Prof.dr.ir. CJ van Duijn



Prof.dr. JJM Slot

The Eindhoven Applied Analysis group focuses on modeling, analysis of nonlinear differential equations and related computational methods. This diverse expertise is applied to a broad spectrum of problems arising in the engineering sciences, physics and industry. The philosophy is to contribute to the solution of relevant problems in these applied sciences as well as to participate in the development of the underlying mathematical framework. At the moment the main areas of applications are fluid mechanics, rheology, material science (including polymers) and porous media. For example:

#### **Porous media**

Porous media are (micro-) structures that appear in many disciplines of science and engineering, like ground water hydrology, soil mechanics, petroleum engineering, bioremediation, agricultural science, tissue engineering, or paper production. Typical for such problems is that different phenomena take place on different scales. One of the research topics is upscaling microstructures to macromodels. Examples are problems from hydrology, like groundwater flow, in particular seawater intrusion in coastal waters, contamination of aquifers, or subsurface storage of materials.

#### **Thermo acoustics**

Thermo acoustics, broadly speaking, deals with all kinds of acoustic effects in which heat conduction and entropy variations in the gaseous medium play a role. Although the study of these phenomena dates back to Lord Rayleigh, it has increasingly become an active area of research with lots of potential applications ranging from upgrading of industrial waste heat to environmentally friendly refrigeration. A focal area of interest is the development of mathematical models for the two main classes of thermo acoustic devices: prime movers that convert heat into sound and heat pumps that convert sound into heat.

#### **Aero acoustics**

One of the many measures taken to reduce the noise of aircraft engines is the application of acoustic lining in the inlet and bypass duct. In order to optimize the damping properties we need to model the sound propagation through the duct. By utilizing the inherent slow variation of a typical flow duct we found an analytic asymptotic solution of the problem that appeared to compare very favorably with proven numerical solutions. This solution was the starting point of a series of similar solutions for related cases, while it has been used to produce a superior matching procedure to connect CFD-type source data to the acoustic field, which is now being used throughout Europe to support CAA implementations.

#### **Rheology**

Rheology is the branch of science focusing on the flow and deformation behavior of complex materials. Complex materials often contain long molecules and/or particles that give them particular flow and deformation behavior in comparison with simple fluids like water or simple solids like pure metals. Examples can be found in industry, the environment, living systems and around the house: paints, polymer processing, production of tires, ink, glues, pharmaceutical -, agricultural - and cosmetic products, in oil production, production of photographic materials, displays and magnetic tapes, food products such as mayonnaise, cheese, margarine, domestic products like toothpaste and liquid detergents, mud, clay, blood and saliva. As in all branches of science also in rheology, in addition to experiment, mathematical modeling and numerical simulation play a very important role. From its inception in the beginning of the last century, when it involved almost exclusively continuum mechanics and constitutive modeling, rheology heavily relies on disciplines belonging to classical applied mathematics, such as differential equations, functional analysis, perturbation theory etc. However, with the increasing focus on the relationship between microscopic structure/processes and macroscopic properties of these complex materials nowadays, probability theory and in particular the theory of stochastic processes has become an essential discipline too. Currently, two focal areas of interest are the constitutive modeling of concentrated solutions of main chain liquid crystalline polymers and that of melts of entangled arbitrarily branched polymers.

**PROJECT AIM**

This work addresses mathematical and numerical analysis questions related to non-standard porous media flow models, and investigate the effect of different capillary pressure assumptions. In particular, we seek for non-standard entropy solutions to two-phase porous media flow problems, as limit cases when the capillary effects vanish.

**PROGRESS**

In 2010 we continued investigating the nonlinear and possibly degenerate models arising as two-phase flow porous media model involving a dynamic capillary pressure. Firstly, we consider a simpler model, where the degeneracy only appears in the second order term. The existence and uniqueness of weak solution were proved. The convergence of the corresponding numerical scheme was also proved, with some numerical simulations provided. Then we prove the existence of the weak solution for a more complex model, where the degeneracy appears in the third order term. Three papers were submitted.

**DISSERTATIONS**

-

**SCIENTIFIC PUBLICATIONS**

-

**PROJECTLEADERS**

CJ van Duijn

**RESEARCHTHEME**

Mathematical and computational methods for fluid flow analysis

**PARTICIPANTS**

Y Fan, IS Pop, CJ van Duijn

**COOPERATIONS**

Dr. C. Cances (Paris), Dr. C.

Choquet (Marseille), Prof. dr.ir.

S.M. Hassanizadeh (Utrecht), Prof.

dr.ir. R. Helmig (Stuttgart), Prof. dr.

A. Mikelic (Lyon), Prof. dr. ir. L.A.

Peletier(Leiden)

**FUNDED**

TUE

University 100%

FOM -

STW -

NWO Other -

Industry -

TNO -

GTI -

EU -

Scholarships -

**START OF THE PROJECT**

2008

**INFORMATION**

Y Fan

040 247 4847

y.fan@tue.nl

**PROJECT LEADERS**

P Notten, MA Peletier, IS Pop

**RESEARCH THEME**

Complex dynamics of fluids

**PARTICIPANTS**K Kumar, TL van Noorden, P Notten,  
MA Peletier, IS Pop**COOPERATIONS**

Prof. R. Helmig (Stuttgart)

Prof. W. Jäger (Heidelberg)

Prof. A. Mikelić (Lyon)

Dr. M. Neuss-Radu (Heidelberg)

**FUNDED**

STW

University -

FOM -

STW 100%

NWO Other -

Industry -

TNO -

GTI -

EU -

Scholarships -

**START OF THE PROJECT**

2008

**INFORMATION**

K Kumar

040 247 4847

K.Kumar@tue.nl

**PROJECT AIM**

The project is related to the development of all-solid state rechargeable batteries having a high storage capacity. Such devices have a complex 3D geometry for the electrodes to enhance the surface area. The challenges are in the development of the appropriate technologies for the formation of these electrodes. In particular we focus on chemical vapor deposition processes (CVD), with the aim of getting a deeper understanding of the reactions taking place in a complex geometry.

**PROGRESS**

Depending on the size of the reaction domain, the changes in the pore structure that are due to the deposition process may or may not be neglected. In mathematical terms, the models are defined in a fixed, respectively variable geometry, when the deposition layer generates a free boundary at the pore scale. We have developed mathematical models for both situations and carried out numerical simulations for both the fixed geometry and variable geometry showing a good agreement with the experimental results obtained for the deposition of Titanium dioxide inside trenches of different diameters. This work has implied determining the physical and chemical parameters. Furthermore, to understand the flow in a domain with variable geometry, we have considered a thin strip with reactions taking place at the lateral boundaries of the strip under dominant transport conditions. We have derived upscaled equations for the solute concentration, which are similar to the Taylor dispersion and we have performed numerical simulations to compare the upscaled equations with other simpler upscaled equations. We have studied the rigorous homogenization process for the reactive flows for a periodic array of cells and proved the validity of upscaled equations. Furthermore, we have derived effective boundary conditions replacing the oscillatory boundary for the situation when the geometry changes at the microscale.

**DISSERTATIONS**

-

**SCIENTIFIC PUBLICATIONS**

1. Thornton, A., Weinhart, T., Bokhove, O., Zhang, B., Sar, D.M. van der, Kumar, K., Pisarenco, M., Rudnaya, M., Savcenko, V., Rademacher, J., Zijlstra, J., Szabelska, A., Zyprych, J., Schans, M. van der, Timperio, V., Veerman, F. (2010). Modeling and optimization of algae growth. Proceedings of the 72nd European Study Group Mathematics with Industry (SWI 2010, Amsterdam, The Netherlands, January 25-29, 2010). (pp. 54-85). Amsterdam: CWI.

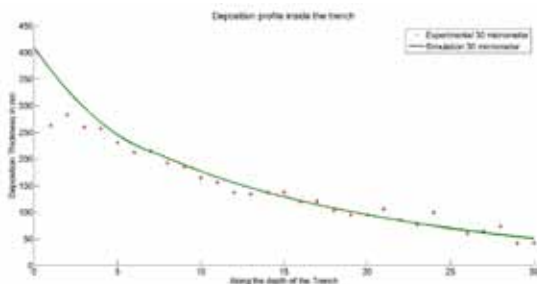
Film thickness profile in trenches of 30  $\mu\text{m}$  wide

## CONSTITUTIVE MODELING OF CONCENTRATED SOLUTIONS OF MAIN-CHAIN LIQUID CRYSTALLINE POLYMERS

### PROJECT AIM

The primary objective of this project is to develop a molecularly based constitutive model for the rheological behavior of concentrated solutions of main-chain liquid crystalline polymers (LCP) that may show nematic order. The model will be restricted to monodomain (single director) morphologies and the main focus will be on the role that chain flexibility plays in this behavior.

### PROGRESS

In 2010 a Rouse-like model for the description of highly-ordered concentrated solutions of LCP was developed and in the framework of this model the linear viscoelastic response in elongational flow was analysed. These results were presented in June at the TU/e-CASA-day and in October at the Annual Meeting of the Society of Rheology. The code to simulate the viscoelastic properties in the shear flow was developed. On the basis of simulations the behavior of the monodomain LCP solution was analyzed. In the last quarter of 2010 we focused on studying the possibilities to include entanglements in the above mentioned Rouse-like model. It was decided to treat entanglements by means of introducing slip-links. This work is still in progress.

### DISSERTATIONS

-

### SCIENTIFIC PUBLICATIONS

1. O.Matveichuk, J.J.M.Slot CASA report 10-73. A Rouse-like model for highly-ordered main-chain liquid crystalline polymers containing hairpins.

### PROJECTLEADERS

JJM Slot

### RESEARCHTHEME

Complex dynamics of fluids

### PARTICIPANTS

O Matveichuk

### COOPERATIONS

Prof. dr. J. Molenaar (WUR),

Prof. dr. S. Picken (TUD),

Teijin Aramid R&D

### FUNDED

Teijin-Aramid BV

University -

FOM -

STW -

NWO Other -

Industry 100%

TNO -

GTI -

EU -

Scholarships -

### START OF THE PROJECT

2008

### INFORMATION

JJM Slot

040 247 4381

[jj.m.slot@tue.nl](mailto:jj.m.slot@tue.nl)

**PROJECT LEADERS**

JJM Slot

**RESEARCH THEME**

Complex dynamics of fluids

**PARTICIPANTS**

Volha Shchetnikava

**COOPERATIONS**

Prof. dr. P.D. Iedema, UvA

**FUNDED**

Dutch Polymer Institute (DPI)

University -

FOM -

STW -

NWO Other 100%

Industry -

TNO -

GTI -

EU -

Scholarships -

**START OF THE PROJECT**

2009

**INFORMATION**

JJM Slot

040 247 4381

j.j.m.slot@tue.nl

**PROJECT AIM**

The primary objective of this project is to develop a molecularly based constitutive model for the rheological behavior of polymer melts consisting of arbitrary branched polymer molecules. An industrially relevant and prime example of such a system is provided by a melt of low-density polyethylene (LDPE). As such a system shows such an extreme variation in molecular composition, a description of this composition can only be given in statistical terms. Hence, the idea is to describe such a system by a finite set (ensemble) of representative molecular structures (topologies). Such an ensemble can be obtained via a combination of kinetic modeling and Monte Carlo simulation. The work on kinetic modeling and Monte Carlo simulation will be done at the University of Amsterdam in a twin PhD project (not part of the JMBC).

**PROGRESS**

We have reached the conclusion that extending the tube theory to the case of arbitrary branched polymers is a very difficult and daunting task. Therefore, we decided to switch to another theoretical approach, namely the well-known Curtiss-Bird theory. This theory is part of more elaborate framework, the so called phase-space kinetic theory of polymer liquids. First we started investigating the potential of this theory for the case of unentangled branched polymers. We have formulated the theory and derived an expression for the stress relaxation modulus for the case of a time-dependent shear flow. We want to study how the rheological response of ensembles of arbitrary branched polymers depends on the architectural complexity of the polymer molecules. Also, we have started to address the problem of how to introduce entanglements in this model. One of the ideas that we are currently investigating is that of sliplinks.

**DISSERTATIONS**

-

**SCIENTIFIC PUBLICATIONS**

-







Prof.dr.ir. FN van de Vosse

The Cardiovascular Biomechanics group at the department of Biomedical Engineering aims to promote the use of experimentally validated predictive mathematical modeling, both in diagnosis and selection of therapy in clinical practice as well as in research and development in the medical device industry. The research in the group is divided in 4 areas of which the first is embedded in JMBC.

### **1. HEMODYNAMICS**

Hemodynamic factors such as like local pressure, velocity, wall shear stress and wall deformation are crucial for the proper functioning of the vascular system, the heart and its native valves. These factors play a key role in the genesis of vascular disease and, when measured properly, can also be predictive for the development of cardiovascular disease. Hemodynamics research in the group is focused on the development of mathematical models and the corresponding computational methods based on finite and spectral element approximations. These models are used to understand the functioning and response of the cardiovascular system. The models range from 0D lumped parameter and 1D wave propagation models of the entire cardiovascular system to 3D models of local fluid-structure interaction in specific arterial segments and heart valve dynamics. Both microscopic (blood as a suspension) as well as macroscopic (blood-wall interaction) scales are considered. In vitro laboratory experiments and measurement techniques are designed and used to validate the outcome of the computational simulations.

### **2. MECHANICS AND ADAPTATION**

Cardiovascular mechanics research is focused on the understanding of the mechanical response of vascular and cardiac tissue to mechanical loads, caused by the pulse wave propagation and cardiac contraction, as well as external forces caused by medical interventions.

### **3. INSTRUMENTATION AND DEVICES**

Medical instrumentation and devices like ultrasound image modalities, pressure and flow sensors, particularly those used for advanced diagnostic measurements.

### **4. CLINICAL RESEARCH**

Through pilot or full clinical studies, in which patient data are gathered and used as input for patient specific modelling, evaluation of the predictive value of mathematical models to predict outcome of medical intervention can be performed.

# VASCULAR REMODELING AFTER THE CREATION OF AN ARTERIOVENOUS FISTULA FOR HEMODIALYSIS

## PROJECT AIM

Hemodialysis dependent patients, need a well-functioning vascular access to connect them with the dialyzer. Usually, the vascular access is surgically created by making a connection between an artery and a vein in the arm. For the planning of the type of vascular access for each individual patient, it is very important to preoperatively predict the postoperative flow increase and vessel remodeling. A lumped patient-specific computer simulation model, based on preoperative MRA and duplex data, is developed to give insight in the postoperative blood flow increase and failure incidence for different fistula configurations.

## PROGRESS

We aim at supporting vascular access surgery by using a pulse wave propagation model for flow prediction. Model input consists of patient data, which is often sparse, incomplete and imprecise. This largely affects the uncertainty and reliability of the model prediction. The goal of the current phase of the study is to depict the contribution of each model parameter to the uncertainty in the postoperative flow prediction by means of a sensitivity analysis. The wave propagation model of the arm vasculature contains 76 parameters describing vessel geometry, mechanical behaviour and boundary conditions. A variance-based method is used to determine the importance of each model parameter.

## DISSERTATIONS

-

## SCIENTIFIC PUBLICATIONS

1. W. Huberts, E.M.H. Bosboom, A. Bode, R.N. Planken, J.H.M. Tordoir, F.N. van de Vosse, A computational model to support the decision-making in vascular access planning, in 17th Congress of the European Society of Biomechanics; Edinburgh, United Kingdom (2010).
2. T. Lavrijsen, W. Huberts, A. Bode, E.M.H. Bosboom, F.N. van de Vosse, Determination of the dynamic behaviour of the cephalic vein, in 17th Congress of the European Society of Biomechanics; Edinburgh, United Kingdom (2010).
3. J.W. Kroon, W. Huberts, E.M.H. Bosboom, F.N. van de Vosse, On linearization, discretization and coupling of 0D and 1D models for estimating vascular hemodynamics, in 6th World Congress on Biomechanics; Singapore, Singapore, (2010).

## PROJECTLEADERS

FN van de Vosse, EMH Bosboom

## RESEARCHTHEME

Complex dynamics of fluids

## PARTICIPANTS

W Huberts

## COOPERATIONS

Maastricht University Medical Centre (MUMC). Philips Research

## FUNDED

FP7 ARCH

University -

FOM -

STW -

NWO Other -

Industry -

TNO -

GTI -

EU 100%

Scholarships -

## START OF THE PROJECT

2006

## INFORMATION

W Huberts

040 247 4060

W.Huberts@tue.nl

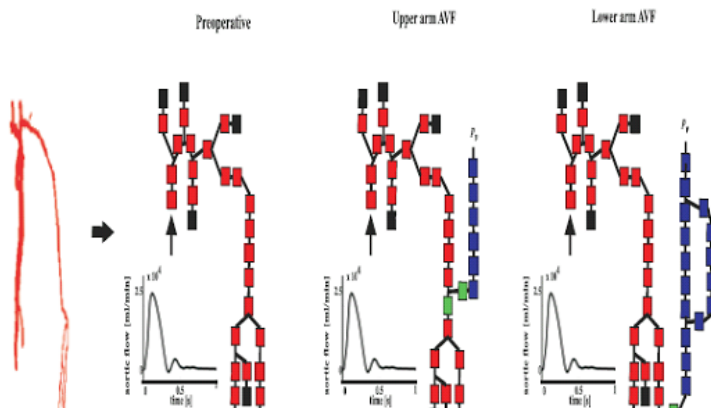

Vascular Network model to predict blood flow after vascular creation of an arteriovenous shunt of the left arm

**PROJECT LEADERS**

FN van de Vosse, ACB Bogaerds

**RESEARCH THEME**

Complex dynamics of fluids

**PARTICIPANTS**

G Mulder

**COOPERATIONS**

Philips Healthcare, University of Sheffield

**FUNDED**

Philips Healthcare.  
 University -  
 FOM -  
 STW -  
 NWO Other -  
 Industry 100%  
 TNO -  
 GTI -  
 EU -  
 Scholarships -

**START OF THE PROJECT**

2006

**INFORMATION**

G Mulder  
 040 247 5169  
 g.mulder@tue.nl

**PROJECT AIM**

Cerebral aneurysms are localized, thin walled dilatations of the arterial wall in the brain. The major risk is rupture, for which a parametric estimate is sought. A 1D wave propagation model and 3D computational fluid dynamics (CFD) model are combined in order to make full use of each model's strength. A biomechanical analysis of flow and stress based on patientspecific input is used to improve the diagnostics. The computational methods are validated using clinical measurements of pressure and flow and 3D PIV measurements in in-vitro set-ups.

**PROGRESS**

The aim of the study in this period was to evaluate the necessity of, and requirements for, full patient-specific modelling, i.e., both geometry and boundary conditions based on patient data. To this purpose, the flow waveforms obtained with several models from literature and a patient-specific geometry of the arterial tree has been compared. Furthermore, a protocol for a full patient-specific 1D model, including the boundary conditions, has been developed.

**DISSERTATIONS**

-

**SCIENTIFIC PUBLICATIONS**

1. Mulder, A.C.B. Bogaerds, P.M.J. Rongen, F.N. van de Vosse, The influence of contrast agent injection on physiological flow in the circle of Willis, Med. Eng. Phys., 33(2), 195-203, (2010).

The geometry is derived from patient-data, affecting the flow waveforms at the boundaries of the 3D model.

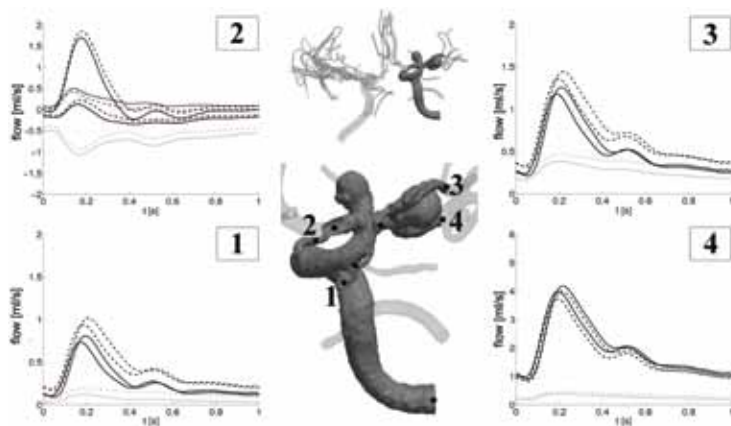

**PROJECT AIM**

In healthy blood vessels, flow is in general laminar and standard computational methods like finite element or finite volume methods based on the linearized Navier-Stokes equations can be used. Distal to mechanical heart valves also transitional (transition to turbulence) flow with small scale local velocity fluctuations can be found. This study will focus on the implementation of spectral elements for fluid structure interaction. The simulations will be compared to flow experiments obtained with PIV, LDA or ultra sound measurements in an in-vitro set-up.

**PROGRESS**

We propose a fully Coupled Overlapping Domain (COD) technique to couple the fixed grid fluid domain with an Arbitrary Lagrangian Eulerian (ALE) moving grid fluid domain. This allows for an optimal conformal coupling between the fluid elements and the structural elements. Rather than employing an iterative strategy between the two fluid layers as is common for Chimera systems, we build a single consistent system for the transient Navier-Stokes equations on the total fluid domain using the standard integration of the elements on the fixed grid that are intersected by the fluid-fluid interface. Using this COD method, an embedded coupling at the fluid-fluid interface is employed. Although, the method that is proposed here, is not restricted to the choice of the discretizations of the fluid domains, we employ Crouzeix-Raviart elements on the ALE fluid domain and a spectral element equivalent (QN-PN-1) on the background mesh. As an example, the figure shows the computational grid and snapshots of the 2-dimensional transient flow around an elastic beam (Re = 150, flow from left to right)

**DISSERTATIONS**

-

**SCIENTIFIC PUBLICATIONS**

1. B.W.A.M.M. Beulen, A.C. Verkaik, N. Bijmens, M.C.M. Rutten, F.N. van de Vosse, Perpendicular ultrasound velocity measurement by 2D cross-correlation of RF data: part B. Volume flow estimation in curved vessels, *Exp. Fluids*, 49(6), 1219-1229, (2010).

Snapshots of the instantaneous vorticity field (right). Also shown is the initial computational domain (left) and the nodal points on the elements of the 'background' spectral (N = 5) mesh that contain degrees of freedom (insert)

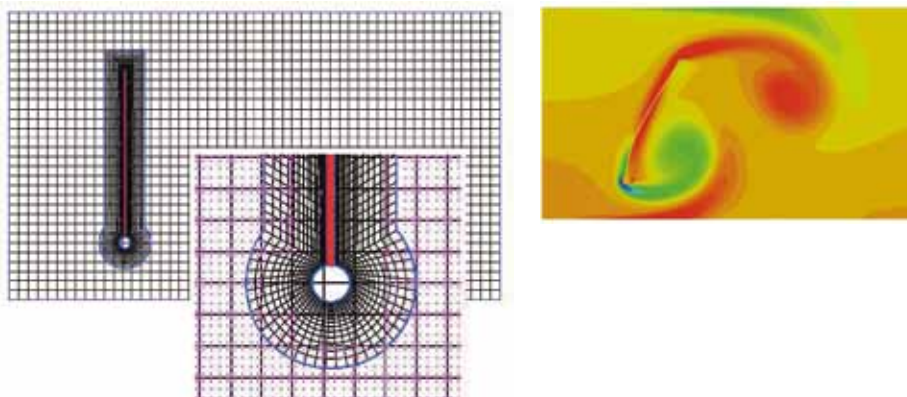

**PROJECTLEADERS**

FN van de Vosse, ACB Bogaerds

**RESEARCHTHEME**

Mathematical and computational methods for fluid flow analysis

**PARTICIPANTS**

AC Verkaik

**COOPERATIONS**

TU/e Mechanical Engineering

**FUNDED**

TUE	
University	100%
FOM	-
STW	-
NWO Other	-
Industry	-
TNO	-
GTI	-
EU	-
Scholarships	-

**START OF THE PROJECT**

2008

**INFORMATION**

AC Verkaik

040 247 3047

A.C.Verkaik@tue.nl

**PROJECT LEADERS**

FN van de Vosse, ACB Bogaerds

**RESEARCH THEME**

Complex dynamics of fluids

**PARTICIPANTS**

RCH van der Burgt

**COOPERATIONS**

TU/e Mechanical Engineering

TU/e Applied Physics

**FUNDED**

TU/e High Potential Research

Program: Blood in Motion

University 100%

FOM -

STW -

NWO Other -

Industry -

TNO -

GTI -

EU -

Scholarships -

**START OF THE PROJECT**

2009

**INFORMATION**

R van der Burgt

040 247 5169

r.c.h.v.d.burgt@tue.nl

**PROJECT AIM**

Because of the high volume contents of red blood cells (RBCs) in blood, mechanics of a single RBC plays a large role in plasma mixing and lateral transport of its components. Therefore, a characterization of the dynamical parameters of RBCs under different flow conditions is needed. Our strategy involves estimation of mechanical properties of the RBC using an inverse analysis which combines both numerical and experimental tools.

**PROGRESS**

An FSI model of the cross-slot, based on the fictitious domain method, is built. (Re)positioning of a RBC to the center is investigated. The boundary conditions of the outflow channels are determined every time step by the coupled feedback system. This model functions as a tool to perform studies to demanded system specifications in terms of valve dynamics, feedback frequency, image analysis, and channel dimensions. 2D-FSI parameter studies provide a useful tool for the design of the cross-slot experiment. With the results of the FSI simulations, experimental setup components have been specified.

**DISSERTATIONS**

-

**SCIENTIFIC PUBLICATIONS**

-

Left: Cross-slot geometry. Fluid velocity is zero at the stagnation point. The cell is repositioned to the center by shifting the stagnation point. This can be achieved by changing the flow ratio of the outflow channels  $Q_1 : Q_2$ . Desired flow ratio is determined by a feedback loop that uses cell position  $x$  as input. Right: FSI results: 2 frames, 2.4 seconds apart, that show trapping of the middle cell in the center.

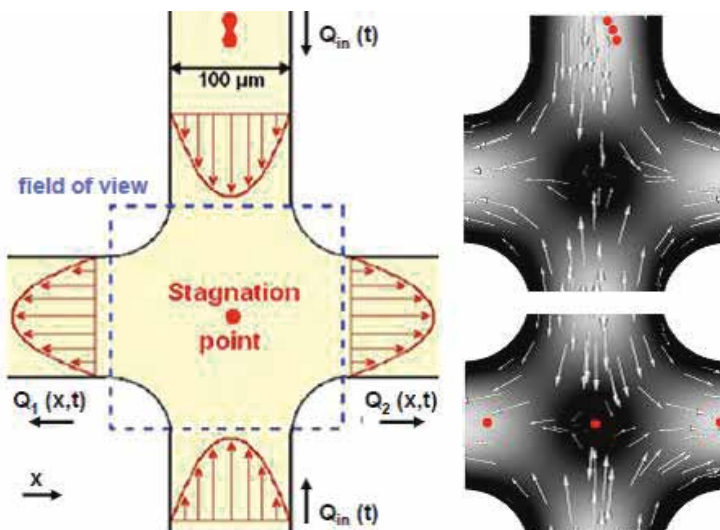

**PROJECT AIM**

Blood coagulation is the complex process by which blood forms clots. It involves the interplay between biochemical and physical processes that occur at different scales. All these factors can be summarized with the Virchow's triad: deviation from normal physiological hemodynamics, injuries to the vascular endothelium layer and changes of the constituents of blood. Aim of the project is to understand how macroscopic changes in blood flow result in the initiation of the coagulation cascade. In order to resolve this question it is necessary to analyze hemodynamics at the macroscopic level (i.e. continuum scale) coupled with the mesoscopic one (i.e. red blood cells scale).

**PROGRESS**

A mesoscopic subproblem is associated to each macroscopic integration point; on each subproblem boundary conditions based on the macroscopic velocity gradient tensor are imposed. By means of each mesoscopic solution, the macroscopic stress tensor is obtained by averaging the mesoscopic stresses over the mesoscopic domain. In order to test the numerical coupling, the momentum equation coupled with the incompressibility constraint is solved on the macroscopic scale (where a quadratic velocity profile is imposed at the inlet) and the Stokes problem is solved on the mesoscopic scale. The macroscopic velocity field and pressure distribution are in good agreement with the standard Poiseuille flow. The next step to validate the numerical coupling is to introduce time on both levels. In this case, the mesoscopic domain moves in time according to the macroscopic shear profile and to the mesoscopic time step. In order to move the mesoscopic mesh in a consistent way, an arbitrary Lagrangian-Eulerian method on the mesoscopic level will be implemented.

**DISSERTATIONS**

-

**SCIENTIFIC PUBLICATIONS**

-

Concurrent coupling scheme: a mesoscopic subproblem is associated to each macroscopic integration point. All problems are discretized using the finite element method (FEM).

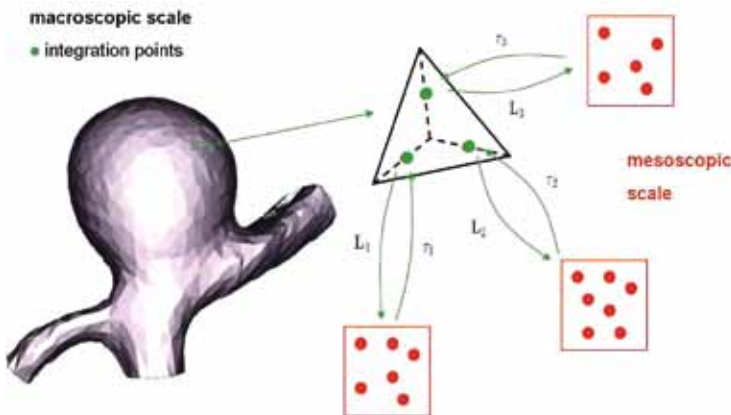

**PROJECT LEADERS**

FN van de Vosse, ACB Bogaerds

**RESEARCH THEME**

Complex dynamics of fluids

**PARTICIPANTS**

F Storti

**COOPERATIONS**

TU/e Mechanical Engineering

TU/e Applied Physics

**FUNDED**

TU/e High Potential Research

Program: Blood in Motion

University 100%

FOM -

STW -

NWO Other -

Industry -

TNO -

GTI -

EU -

Scholarships -

**START OF THE PROJECT**

2010

**INFORMATION**

F Storti

f.storti@tue.nl



Prof.dr.ir. JAM Kuipers



Prof.dr.ir. M van Sint Annaland

The research group SMR participates amongst others in the OSPT and the JMBC for fluid mechanics and focuses on fundamentals of the discipline of chemical reaction engineering. Our main area of interest is the quantitative description of transport phenomena (including fluid flow) and the interplay with chemical transformations in multiphase chemical reactors. The generation of new knowledge and the development of new reactor models with improved predictive capability for this industrially important class of chemical reactors constitutes an important goal of our research activities. Through the intended co-operation with other (application oriented) research groups, both fundamental aspects and those closely related to applications will be studied through concerted action. The main research topics of the new group SMR can be divided into the following three areas: Multiphase Reactors, Advanced Experimental Techniques and Novel Reactors, which will be discussed below in more detail.

An important area of attention is the development of advanced reactor models for multiphase reactors with industrial relevance. At present our research focuses on the hydrodynamics in these reactors because it is generally recognized that the lack of understanding of the flow phenomena is one of the central difficulties in the design and scale-up of multiphase reactors. In the near future the interplay of flow phenomena with chemical reactions will be studied in great detail. We use various types of CFD models (both commercial codes but mostly "in house" made codes) to study the relevant hydrodynamic phenomena at all relevant length and time scales (i.e. at the microscopic, mesoscopic and macroscopic scale). In our group both multifluid models are being developed and models which treat the dispersed phase (particles, bubbles or droplets) in a discrete manner accounting for possible encounters between the dispersed elements.

The second important area of our research deals with the development of advanced experimental techniques to measure key quantities (i.e. local volume fractions and velocities of the dispersed and continuous phase). As an example we can mention the development of the digital particle image velocimetry technique to measure in a non-intrusive manner the velocity map of both the liquid phase and dispersed gas bubbles in (dense) gas-liquid dispersions. This type of flow very often arises in a variety of gas-liquid contactors/reactors. In this area we co-operate with specialists within the J.M. Burgerscentrum for fluid mechanics. Of course this research activity is intimately connected to the first research topic. Our third important area of research deals with the development of novel (multiphase) reactors with emphasis on integration and intensification of relevant process steps. As an example we can mention here the Rapid Reaction Cycling Reverse Flow (RRCRF) which integrates (in a thermal sense) endothermic and exothermic heterogeneously catalyzed chemical reactions where the endothermic reaction causes rapid (reversible) catalyst deactivation. These types of chemical reaction systems often arise in practice for instance in the production of lower alkenes from the corresponding alkanes via heterogeneously catalyzed dehydrogenation. The knowledge and tools developed within the other two areas of attention provide a sound basis to place this research activity on a firm footing.

# CHARACTERIZATION OF THE FLUID DYNAMICS AND DISCRETE PARTICLE MODELLING OF A NOVEL SPOUTED BED APPARATUS

## PROJECT AIM

To develop a spouted bed reactor for material which are difficult to fluidised and investigate the influence of operating parameters on bed dynamics under dry and wet conditions by considering heat and mass transfer effects.

## PROGRESS

The experimental setup for a spouted bed reactor has been constructed accomplished with digital camera for further analysis like particle image velocimetry (PIV) and digital image analysis (DIA). Furthermore, theoretical investigations are formed by considering combination of immersed boundary method and discrete particle model.

## DISSERTATIONS

-

## SCIENTIFIC PUBLICATIONS

-

## PROJECT LEADERS

JAM Kuipers, NG Deen

## RESEARCH THEME

Mathematical and computational methods for fluid flow analysis

## PARTICIPANTS

VS Sutkar

## COOPERATIONS

Prof. S. Heinrich., Dr. S. Antonyuk  
Hamburg University of Technology

## FUNDED

STW & DFG	
University	-
FOM	-
STW	100%
NWO Other	-
Industry	-
TNO	-
GTI	-
EU	-
Scholarships	-

## START OF THE PROJECT

2010

## INFORMATION

JAM Kuipers  
040 247 4158  
J.A.M.Kuipers@TUE.nl  
[www.chem.tue.nl/smr](http://www.chem.tue.nl/smr)



**PROJECT LEADERS**

JAM Kuipers, M van Sint Annaland

**RESEARCH THEME**

Complex dynamics of fluids

**PARTICIPANTS**

T Kolkman

**COOPERATIONS**

-

**FUNDED**

Dutch Polymer Institute

University -

FOM -

STW -

NWO Other 100%

Industry -

TNO -

GTI -

EU -

Scholarships -

**START OF THE PROJECT**

2008

**INFORMATION**

JAM Kuipers

040 247 4158

J.A.M.Kuipers@TUE.nl

www.chem.tue.nl/smr

**PROJECT AIM**

The main objective of this research project is to develop detailed understanding and quantitative descriptive tools for dense fluidized gas-solid suspensions, in which one of the reactants and/or a dedicated component is injected into the bed as a liquid (through bottom or top spraying/atomization), taking into account the associated heat effects. The impact of operating conditions on the fluidization behavior will also be quantified experimentally. The results will be used in further development and validation of advanced in-house developed CFD models. These can subsequently be used to support the design and optimization of engineering-scale gas-phase polymerization reactors with special emphasis on the thermal aspects of the operation.

**PROGRESS**

Demonstration of unique novel experimental approach to directly observe and study agglomerates in and, simultaneously, the hydrodynamics of a fluidized bed with liquid injection using a combination of Particle Image Velocimetry and Infrared Thermography. Major extension of Discrete Particle Model to take into account mass and heat transfer.

**DISSERTATIONS**

-

**SCIENTIFIC PUBLICATIONS**

-

### PROJECT AIM

A front tracking model will be used to simulate small bubbly flow systems in very much detail. The objective is to derive hydrodynamic and mass and heat transfer closures from the simulation results for the regime of high gas volume fractions (i.e. high superficial gas velocities). Swarm effects, i.e., the effects of the presence and behavior of neighboring bubbles, on the mass, momentum, and heat transfer rates will be quantified in the form of correlations, which will be used in other sub-projects of this FOM programme to study bubbly flows on a larger scale (with higher level models).

### PROGRESS

Simulation have been run to derive a closure for the drag force on bubbles in a swarm, dependent on the gas fraction and the bubble size. In addition, we have simulated bi-disperse bubble swarms to derive a similar closure, but now also based on the swarm composition. To simulate mass and heat transfer, a mass-transfer model has been built which is ready to implement in the Front Tracking model.

### DISSERTATIONS

-

### SCIENTIFIC PUBLICATIONS

1. W. Dijkhuizen, I. Roghair, M. Van Sint Annaland, and J.A.M. Kuipers. DNS of gas bubbles behavior using an improved 3D front tracking model—Model development. *Chemical Engineering Science*, 65(4):1427–1437, 2010.
2. W. Dijkhuizen, I. Roghair, M. Van Sint Annaland, and J.A.M. Kuipers. DNS of gas bubbles behavior using an improved 3D front tracking model—Drag force on isolated bubbles and comparison with experiments. *Chemical Engineering Science*, 65(4):1415–1426, 2010.

### PROJECT LEADERS

JAM Kuipers, M Van Sint Annaland,  
NG Deen

### RESEARCH THEME

Mathematical and computational  
methods for fluid flow analysis

### PARTICIPANTS

I Roghair, YM Lau

### COOPERATIONS

D. Lohse, J. Martinez Mercado, R.  
Lakkaraju

### FUNDED

FOM, AkzoNobel, DSM, Shell, Tata  
Steel  
University -  
FOM 50%  
STW -  
NWO Other -  
Industry 50%  
TNO -  
GTI -  
EU -  
Scholarships -

### START OF THE PROJECT 2007

### INFORMATION

JAM Kuipers  
040 247 4158  
J.A.M.Kuipers@TUE.nl  
www.chem.tue.nl/smr

**PROJECT LEADERS**

NG Deen, JAM Kuipers

**RESEARCH THEME**

Mathematical and computational methods for fluid flow analysis

**PARTICIPANTS**

QIE Segers

**COOPERATIONS**

-

**FUNDED**

European Research Council

University -

FOM -

STW -

NWO Other -

Industry -

TNO -

GTI -

EU 100%

Scholarships -

**START OF THE PROJECT**

2010

**INFORMATION**

JAM Kuipers

040 247 4158

J.A.M.Kuipers@TUE.nl

www.chem.tue.nl/smr

**PROJECT AIM**

Selection of proper test system with dyes for concentration measurements in bubbly flows with and without wires.

Measurement of heat and mass transfer rate as function of wire-mesh layout and bubble-mesh distance in flat bubble column.

**PROGRESS**

Literature study into Front Tracking method and Immersed Boundary method in computational fluid dynamics. Getting acquainted with the DNS code readily developed in the group. Calculation of some test cases in 2D and 3D and evaluating with literature.

**DISSERTATIONS**

-

**SCIENTIFIC PUBLICATIONS**

-

## DEVELOPMENT OF SIMULATION MODELS FOR POLYDISPERSED GAS SOLID FLUIDIZED BED REACTORS

### PROJECT AIM

This project is concerned with the modeling at the largest scale, using the KTGF, with a focus on the effects of polydispersity, starting with bidispersity. For this, novel closures for the solid phase viscosity and gas-solid momentum exchange have to be developed and/or implemented. Subsequently, all the steps taken initially for binary systems of fluidized beds are to be extended to general poly-disperse systems.

### PROGRESS

Detailed and somewhat satisfactory comparison was made for mono-dispersed system between a newly developed Multi-Fluid Model and the more established Two Fluid Model and the Discrete Element Model. Further studies were carried out on the sensitivity of the MFM to key parameters like maximum particle fraction, restitution coefficient and drag models for bi-dispersed beds.

### DISSERTATIONS

-

### SCIENTIFIC PUBLICATIONS

1. Olasaju Olaofe, M. van der Hoef, J.A.M. Kuipers. Bubble formation at a single orifice in a 2D gas-fluidised bed. World Congress on Particle Technology (WCPT) 6, Nuremberg, Germany.
2. Olasaju Olaofe, Albert Bokkers, Martin van Sint Annaland, Martin van der Hoef and Hans Kuipers. Multi-Fluid Model Simulation of Bed Expansion, Particle Mixing and Segregation in Bi-disperse Gas Fluidized Beds. 7th International Conference on Multiphase Flow, ICMF 2010, Tampa, FL, USA.

### PROJECT LEADERS

JAM Kuipers, MA van der Hoef

### RESEARCH THEME

Mathematical and computational methods for fluid flow analysis

### PARTICIPANTS

OO Olaofe

### COOPERATIONS

-

### FUNDED

NWO	
University	-
FOM	-
STW	-
NWO Other	100%
Industry	-
TNO	-
GTI	-
EU	-
Scholarships	-

### START OF THE PROJECT

2008

### INFORMATION

JAM Kuipers  
040 247 4158  
J.A.M.Kuipers@TUE.nl  
[www.chem.tue.nl/smr](http://www.chem.tue.nl/smr)

## AUTOTHERMAL MEMBRANE REACTOR FOR THE PRODUCTION OF ULTRA-PURE HYDROGEN WITH INTEGRATED CO<sub>2</sub> CAPTURE

### PROJECT LEADERS

JAM Kuipers, M van Sint Annaland

### RESEARCH THEME

Mathematical and computational methods for fluid flow analysis

### PARTICIPANTS

JF de Jong

### COOPERATIONS

Inorganic Membrane Group,  
University of Twente, the  
Netherlands

### FUNDED

SenterNovem  
University -  
FOM -  
STW -  
NWO Other 100%  
Industry -  
TNO -  
GTI -  
EU -  
Scholarships -

### START OF THE PROJECT

2007

### INFORMATION

M van Sint Annaland  
040 247 2241  
M.v.SintAnnaland@TUE.nl  
www.chem.tue.nl/smr

### PROJECT AIM

By means of fundamental research and an experimental demonstration unit, this project aims to provide proof-of-principle on the novel reactor concept with palladium membranes as well as perovskite membranes for oxygen separation. The effect of the presence of – and permeation through – membranes inside a fluidized bed hydrodynamics (in particular particle circulation patterns and bubble size distribution) will form the basis for a strong reactor design. This reactor will be built and tested.

### PROGRESS

A pseudo-2D setup has been built to investigate the phenomena inside a fluidized bed using Particle Image Velocimetry (PIV). The focus lies in the beginning on permeation through vertical membranes for which gas addition as well as gas extraction is investigated. The experimental results are then compared to the Discrete Particle Model (DPM). In order to simulate membrane tubes, the Immersed Boundary Method (IBM) was implemented into the model and tested.

### DISSERTATIONS

-

### SCIENTIFIC PUBLICATIONS

-



Snapshot of eight immersed membrane tubes in a DPM simulation

## COALESCENCE, BREAKUP & SCALE EFFECTS IN HETEROGENEOUS BUBBLY FLOW

### PROJECT AIM

To attain a validated Euler-Lagrange model for the description of heterogeneous bubbly flow, with the incorporation of coalescence and breakup of bubbles.

### PROGRESS

A breakup model has been implemented in an Euler-Lagrange framework. Within this model, breakup of a bubble is based on a force balance between the turbulent stresses, which tend to deform the bubble shape, and the surface restoring forces (surface tension). Due to some arbitrary parameters in the model, simulations are performed to determine their effects on the overall bubbly flow. Also a from DNS-derived drag closure, which takes into the account the swarm effects, has been implemented and investigated.

### DISSERTATIONS

-

### SCIENTIFIC PUBLICATIONS

1. Lau, Y.M., Deen, N.G. and Kuipers, J.A.M., Bubble Breakup in Euler-Lagrange Simulations of Bubbly Flow, 7th International Conference on Multiphase Flow, ICMF 2010, Tampa, FL, USA.

### PROJECT LEADERS

JAM Kuipers, NG Deen

### RESEARCH THEME

Mathematical and computational methods for fluid flow analysis

### PARTICIPANTS

YM Lau

### COOPERATIONS

-

### FUNDED

FOM, AkzoNobel, DSM, Shell and Tata Steel

University

-

FOM

50%

STW

-

NWO Other

-

Industry

50%

TNO

-

GTI

-

EU

-

Scholarships

-

### START OF THE PROJECT

2008

### INFORMATION

JAM Kuipers

040 247 4158

J.A.M.Kuipers@TUE.nl

[www.chem.tue.nl/smr](http://www.chem.tue.nl/smr)

**PROJECT LEADERS**

NG Deen, JAM Kuipers

**RESEARCH THEME**

Mathematical and computational methods for fluid flow analysis

**PARTICIPANTS**

D Jain

**COOPERATIONS**

-

**FUNDED**

European Research Council

University -

FOM -

STW -

NWO Other -

Industry -

TNO -

GTI -

EU 100%

Scholarships -

**START OF THE PROJECT**

2010

**INFORMATION**

JAM Kuipers

040 247 4158

J.A.M.Kuipers@TUE.nl

www.chem.tue.nl/smr

**PROJECT AIM**

The particle behavior varies within the liquid layer depending on the liquid physical properties such as viscosity, surface tension, layer thickness, and on particle properties as density ratio, impact velocity, etc. The project objective is to analyze and postulate the dependence of the coefficient of restitution of a particle in a liquid layer on various physical parameters. The simulation model used in current study is based on basic momentum (Navier-Stokes equation) and Continuity equations to overcome the disadvantages of phenomenological models. This model then will be used to find the correlations for restitution coefficient of particle-fluid interaction. This information will then be utilized to model the behavior in industrial scale fluidized beds.

**PROGRESS**

Literature study has been performed for the prevailing models and experimental results for the particle impaction and the analysis techniques have been studied. Results confirm that the thin liquid layers and high impact velocities lead to bounce back from the liquid layer while more thickness and low velocities lead to particle sticking back in liquid film. Moreover, trends for overall restitution coefficient values with varying impact velocities and film thicknesses match well with the experimental curves obtained from a previous study. Since, the results from our simulation model are found to be in good agreement with the experimental findings, we are looking forward understand the phenomenon at more basic level.

**DISSERTATIONS**

-

**SCIENTIFIC PUBLICATIONS**

-

Simulation results (left); Experimental results (right) Ref. Antonyuk et al. 2009; Influence of impact velocity on restitution coefficient of Al<sub>2</sub>O<sub>3</sub> granules impacting on water layers with varying thickness

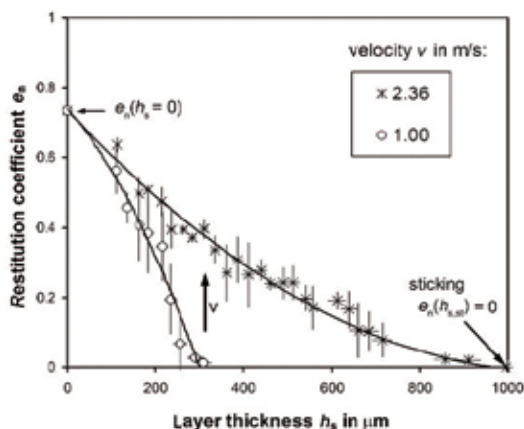
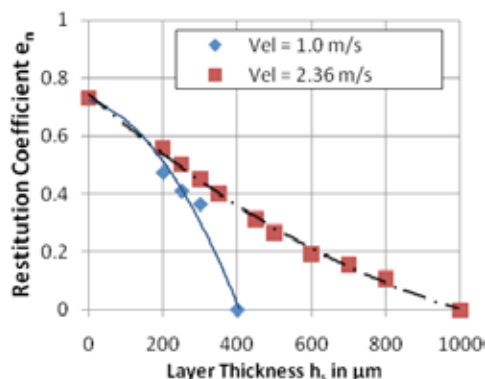

# NEXT GENERATION MICROREACTORS FOR ULTRA-PURE H<sub>2</sub> PRODUCTION

## PROJECT AIM

The objective of this research is to design a micro-fluidized bed membrane reactor for ultra-pure H<sub>2</sub> production based on the studies in concerted action by detailed simulations using advanced fundamental models and advance experimental techniques.

## PROGRESS

Simulation works on the regime transition (specially the regime transition from bubbling fluidization to turbulent fluidization) in micro fluidized bed and the effect of gas permeation through membranes on the hydrodynamics of the membrane assisted micro fluidized bed haven been carried out. Novel experimental setups have been designed and constructed for hydrodynamic study using Particle Image Velocimetry and Digital Image Analysis techniques at differential operating conditions. Infrared camera as a novel noninvasive experimental technique has been applied for gas back mixing study.

## DISSERTATIONS

-

## SCIENTIFIC PUBLICATIONS

1. Junwu Wang, Lianghui Tan, M.A. van der Hoef, M. van Sint Annaland and J.A.M. Kuipers (2010): From bubbling to turbulent fluidization: Advanced onset of regime transition in micro-fluidized beds, Chemical Engineering Science, Volume 66, issue 9, 1 May 2011, pages 2001-2007.

## PROJECT LEADERS

M van Sint Annaland

## RESEARCH THEME

Mathematical and computational methods for fluid flow analysis

## PARTICIPANTS

N Dang, L Tan

## COOPERATIONS

Dr. O Bokhove (UT)

## FUNDED

STW	
University	-
FOM	-
STW	100%
NWO Other	-
Industry	-
TNO	-
GTI	-
EU	-
Scholarships	-

## START OF THE PROJECT

2009

## INFORMATION

M van Sint Annaland

040 247 2241

M.v.SintAnnaland@TUE.nl

[www.chem.tue.nl/smr](http://www.chem.tue.nl/smr)

Effect of gas permeation through membranes on the solid circulation pattern in the micro membrane fluidized bed (outlet superficial gas velocity=0.05m/s)

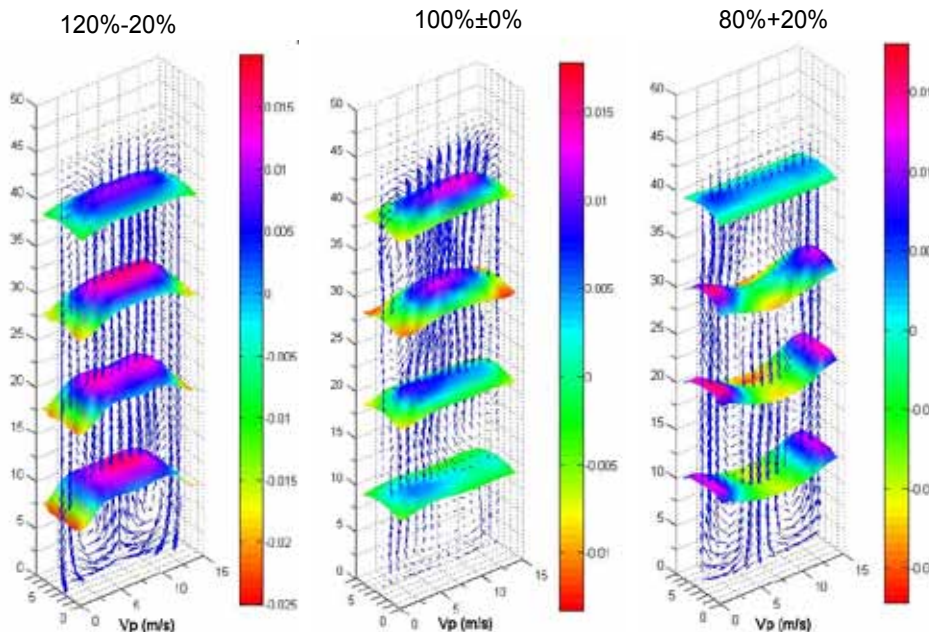



**PROJECTLEADERS**

M van Sint Annaland

**RESEARCHTHEME**

Complex dynamics of fluids

**PARTICIPANTS**

HM Slagter

**COOPERATIONS**

-

**FUNDED**

DPI

University -

FOM -

STW -

NWO Other 100%

Industry -

TNO -

GTI -

EU -

Scholarships -

**START OF THE PROJECT**

2010

**INFORMATION**

M van Sint Annaland

040 247 2241

M.v.SintAnnaland@TUE.nl

www.chem.tue.nl/smr

**PROJECT AIM**

The main objective of this PhD research is to fundamentally understand and quantitatively describe the complex interaction between the hydrodynamics in the fluidized bed and the sorption and transport phenomena in/around polymer particles. A combined computational and experimental approach is used in this research. The in-house developed CFD models will be adapted to account for sorption and swelling effects of the particles and their influence on the collision parameters. For the validation of the numerical models a pseudo 2D, dense fluidized bed will be used. Constructed and non-invasive optical measuring techniques like PIV and DIA will be used.

**PROGRESS**

Literature study into the behavior of the fluidized bed with respect to the properties of the particles and the computational models which will be used. First simulations are done and analyzed.

**DISSERTATIONS**

-

**SCIENTIFIC PUBLICATIONS**

-

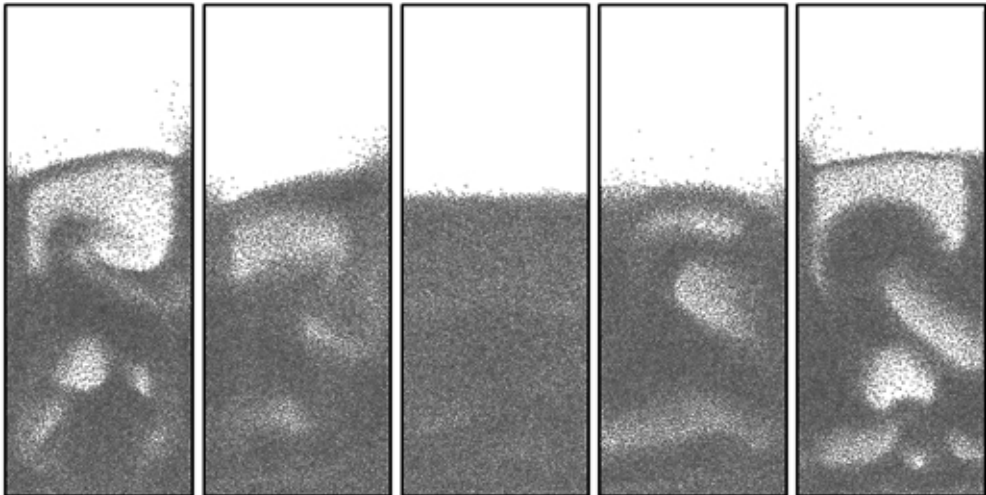

Results of computer simulations with a discrete particle model investigating the influence of collisional parameters. Centre: ideal solids without collisional energy dissipation; Left: smaller normal restitution coefficient; Right: higher friction coefficient.

## DIRECT NUMERICAL SIMULATION OF MOMENTUM AND HEAT TRANSFER IN DENSE GAS-SOLID FLOWS

### PROJECT AIM

The objective of this study is to proposed new momentum and heat correlations for dense arrays of non-spherical particles (e.g. cylindrical particle) for both creeping flow and moderate Reynold flow based on accurate numerical data from simulation. The basis of our research approach is the direct numerical simulation level of modeling, in which the exchange of mass, momentum and heat can be modeled without the use of any assumptions or empirical correlations.

### PROGRESS

Using the Immersed Boundary method, we calculate the drag force on an isolated cylinder in an unbounded fluid, for which theoretical estimates exist. To mimic an infinite array , we use periodic boundary conditions, so that we effectively model a very dilute square array of cylinders. A correction is applied to reduce the effect of the periodic images. The Immersed Boundary method has been extended to solve heat transfer problems. The simulations of some well known test cases have been conducted to validate the accuracy of the method on solving heat transfer problems.

### DISSERTATIONS

-

### SCIENTIFIC PUBLICATIONS

-

### PROJECTLEADERS

JAM Kuipers, MA van der Hoef

### RESEARCHTHEME

Mathematical and computational methods for fluid flow analysis

### PARTICIPANTS

H Tavassoli

### COOPERATIONS

-

### FUNDED

ERC	
University	-
FOM	-
STW	-
NWO Other	-
Industry	-
TNO	-
GTI	-
EU	100%
Scholarships	-

### START OF THE PROJECT

2010

### INFORMATION

JAM Kuipers  
040 247 4158  
J.A.M.Kuipers@TUE.nl  
[www.chem.tue.nl/smr](http://www.chem.tue.nl/smr)

**PROJECT LEADERS**

JAM Kuipers, MA van der Hoef

**RESEARCH THEME**

Mathematical and computational methods for fluid flow analysis

**PARTICIPANTS**

A Patil

**COOPERATIONS**

-

**FUNDED**

European Research Council

University -

FOM -

STW -

NWO Other -

Industry -

TNO -

GTI -

EU 100%

Scholarships -

**START OF THE PROJECT**

2010

**INFORMATION**

JAM Kuipers

040 247 4158

J.A.M.Kuipers@TUE.nl

www.chem.tue.nl/smr

**PROJECT AIM**

The aim of the project is to extend the multi-scale modeling of gas-fluidized beds with mass and heat transfer, where previously only momentum transfer between the gas and solid phase was considered.

**PROGRESS**

Presently a preliminary understanding of the Discrete particle model (DPM) code is being done in order to get the knowledge to build a new DPM code. The DPM code is primarily made of two parts: the Eulerian part which models the fluid flow and the Lagrangian part which models the discrete particle flow. The Eulerian flow is simulated on a grid and coupled with the solid phase flow using interaction parameters like drag coefficient. In order to evaluate such parameters the gas porosity of the grid cells are needed to be calculated. For this purpose solid volume in cells is calculated by directly evaluating volume of the particles in given cells. So the particles on the cell wall need to be evaluated with cut volume of the particles (sphere cap volume) only. In order to obtain computing efficiency a fictional cube of volume same as the sphere is used instead. This implementation was made to the DPM to evaluate the cut volume.

**DISSERTATIONS**

-

**SCIENTIFIC PUBLICATIONS**

-

## POLYDISPERSED GRANULAR FLOWS THROUGH INCLINED CHANNELS

### PROJECT AIM

The aims of the project are

- Study the flow behavior of dry granular material on inclined non-rotating and rotating channels.
- Prediction of influences of polydispersity and non-uniformity of the particles, rotation and particle segregation.
- To compare the simulation results with experimental measurements.

### PROGRESS

Literature studies have been done on granular flow through inclined channels(chutes). Getting acquainted with DEM simulation software which is modified for flow of monodispered dry granular particles. Simulation work is in progress using 3D discrete particle model to study the flow behaviour of dry granular matter through an inclined rectangular channel.

### DISSERTATIONS

-

### SCIENTIFIC PUBLICATIONS

-

### PROJECTLEADERS

JAM Kuipers, MA van der Hoef,  
HJH Clercx

### RESEARCHTHEME

Mathematical and computational  
methods for fluid flow analysis

### PARTICIPANTS

SS Shirsath

### COOPERATIONS

-

### FUNDED

STW and Tata Steel	
University	-
FOM	-
STW	100%
NWO Other	-
Industry	-
TNO	-
GTI	-
EU	-
Scholarships	-

### START OF THE PROJECT

2010

### INFORMATION

JAM Kuipers  
040 247 4158  
J.A.M.Kuipers@TUE.nl  
[www.chem.tue.nl/smr](http://www.chem.tue.nl/smr)

**PROJECT LEADERS**

JAM Kuipers, MA van der Hoef

**RESEARCH THEME**

Complex dynamics of fluids

**PARTICIPANTS**

SHL Kriebitzsch

**COOPERATIONS**

Prof. A.J.C. Ladd (Florida)

**FUNDED**

NWO

University -

FOM -

STW -

NWO Other 100%

Industry -

TNO -

GTI -

EU -

Scholarships -

**START OF THE PROJECT**

2006

**INFORMATION**

JAM Kuipers

040 247 4158

J.A.M.Kuipers@TUE.nl

www.chem.tue.nl/smr

**PROJECT AIM**

Fully resolved simulations of industrially sized fluidized beds are still far beyond the capabilities of current computers. Thus coarsened models have to be used, which do not resolve the flow on length scales comparable to the size of the fluidized particles. To account for physical effects on these small scales, such as momentum exchange between gas and solids, closures are required. Aim of this project is to obtain closures for the drag force in poly-disperse particle gas system using results obtained from lattice Boltzmann and CFD-IBM simulations.

**PROGRESS**

Two different immersed boundary methods were implemented in an in-house CFD code and extensively validated. The hydrodynamic force acting on particles in low-Reynolds number flow was compared to results obtained from lattice-Boltzmann simulations and to exact solutions of the Stokes equation, that were obtained by multipole expansion. Excellent agreement was found provided that a hydrodynamic diameter was used, which was obtained by comparison of the drag on particles in a dilute periodic simple cubic array. Simulations of small systems of  $O(1000)$  fluidized particles are now on the way and will be compared to DPM simulations of the same system.

**DISSERTATIONS**

-

**SCIENTIFIC PUBLICATIONS**

-

Hydrodynamic interaction of 2 particles

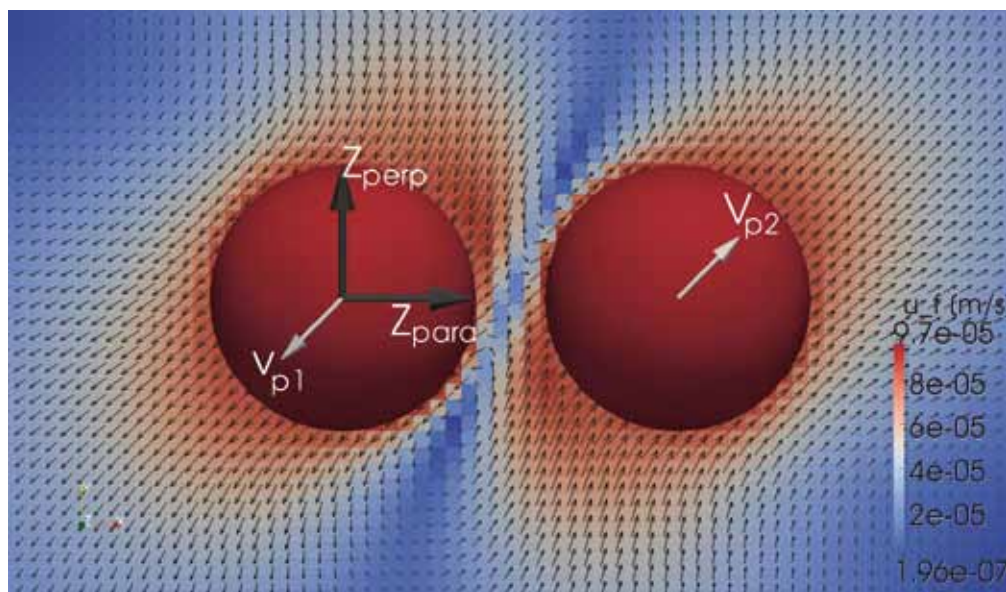





Prof.dr. WJ Briels

At Computational Biophysics we study the rheological properties of complex soft matter. Typical systems are multiphase systems consisting of hard particles, like the rod-like fd virus, dispersed in a Newtonian liquid or soft structures, like spherical or worm-like micelles or lipid bi-layers, resulting from self-assembling amphiphiles dissolved in water. Close to equilibrium the rheological properties are determined by the structural properties of the dispersed phase. Since these structures are usually stabilized by free energies in the order of several  $kT$ , they can easily be modified by applying flow gradients, which then give rise to a modification of the rheological properties as well. Well known phenomena resulting from this interplay between structure and flow are shear thinning, shear banding or temporal oscillations of optical and rheological properties in liquid crystalline polymer solutions.

The tools that we use belong to the field of particle based computer simulations. Since a full description of the observed phenomena requires a multi scale approach, our simulation methods range from simple molecular dynamics to Langevin dynamics and Brownian dynamics. Molecular dynamics simulations are mainly used to calculate free energies at small scales which govern the interactions at the mesoscopic scales. Our strength here is to a large extent in developing new methods. At the mesoscopic level we have developed a new model to describe polymer melt dynamics and are presently working on a new model to describe the rheology of living polymers and worm-like micelles. In the realm of Brownian dynamics, we have introduced event-driven algorithms.

Because the systems under study are mostly of biological relevance, last year the group adopted the name computational biophysics (CBP).

## STRUCTURE FORMATION IN COLLOIDAL SUSPENSIONS IN FLOW AND NEAR WALLS

### PROJECT AIM

Particle based simulations are used to study structure formation of colloids in various types of solvents and flows. The solvents to be simulated range from simple Newtonian to strongly shear-thinning visco-elastic fluids. Flows envisaged include stationary and oscillatory shear, and elongational flows. Colloids will range from spheres to rods and plates. Besides flow, the influence of walls will be studied as well.

### PROGRESS

Two shear-thinning viscoelastic fluids, a polymer and a worm-like micellar solutions, were simulated using the Responsive Particle Dynamics (RaPiD) method. Their rheological properties agree well with experiments. Colloids dispersed in the non-sheared fluids mix homogeneously. Under shear flow, however, the colloids in the worm-like micellar solution align to form strings along the flow direction, see figure, while the colloids in the polymer solution remain randomly distributed. These observations are in agreement with recent experiments. We are currently investigating the still unknown mechanism behind this alignment. Simulations on the influence of walls in these system have started.

### DISSERTATIONS

-

### SCIENTIFIC PUBLICATIONS

-

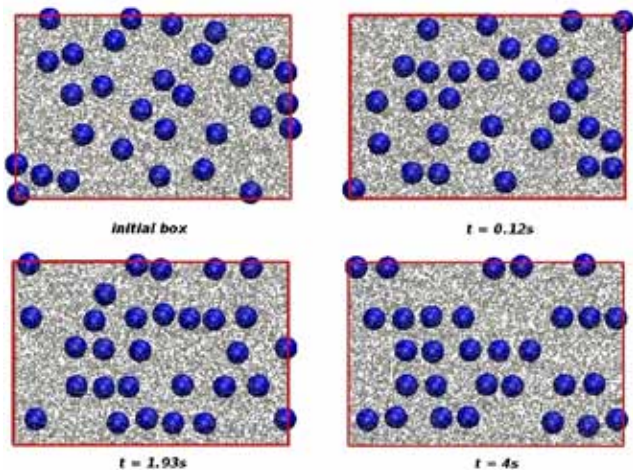

### PROJECTLEADERS

WJ Briels

### RESEARCHTHEME

Complex dynamics of fluids

### PARTICIPANTS

IS Santos de Oliveira, WK den Otter

### COOPERATIONS

JT Padding (UT & Leuven, B)

Prof.dr. J Vermant (Leuven, B)

Prof.dr. JKG Dhont (Jülich, D)

### FUNDED

EU - nanodirect

University -

FOM -

STW -

NWO Other -

Industry -

TNO -

GTI -

EU 100%

Scholarships -

### START OF THE PROJECT

2008

### INFORMATION

WJ Briels

053 489 2947

w.j.briels@utwente.nl

<http://cbp.tnw.utwente.nl/>



**PROJECT LEADERS**

WJ Briels

**RESEARCH THEME**

Complex dynamics of fluids

**PARTICIPANTS**

L Liu, WK den Otter

**COOPERATIONS**

JT Padding (UT &amp; Leuven, B)

**FUNDED**

EU - dynacop

University -

FOM -

STW -

NWO Other -

Industry -

TNO -

GTI -

EU 100%

Scholarships -

**START OF THE PROJECT**

2009

**INFORMATION**

WJ Briels

053 489 2947

w.j.briels@utwente.nl

<http://cbp.tnw.utwente.nl/>**PROJECT AIM**

Topologically complex polymers, such as star or comb or H-shaped branched polymers, exhibit complex dynamics and rheology, and often show hierarchical relaxation over many different time scales. This in turn affects the processing and properties of their melts, which is a major issue in the industrial application of these polymers.

**PROGRESS**

In order to simulate long branched polymers in an efficient manner, we have developed a hybrid of responsive particle dynamics (RaPiD) and twentanglement. Each RaPiD particle represents an entire linear chain, i.e. an arm of a branched polymer, by a suitably chosen equation of motion including transient memory effects. The uncrossability constraints introduced by the twentanglement algorithm prevents the arms from crossing each other. Simulations are running to study the influence of the topology on the mean square displacement and stress auto-correlation, which will provide information on topology-related relaxation processes. The relaxation processes and time will be compared against theoretical predictions and on-going experiments in collaborating groups within the dynacop network.

**DISSERTATIONS**

-

**SCIENTIFIC PUBLICATIONS**

1. JT Padding, E van Ruymbeke, D Vlassopoulos and WJ Briels, Computer simulations of the rheology of concentrated star polymer suspensions. *Rheol. Acta.* 49, 473 (2010).

### PROJECT AIM

The aim of this study is to gain a comprehensive understanding of the dynamics and material properties of suspensions and gels of fibrillar amyloid aggregates. Significant insight into the dynamics will come from coarse-grained simulations of the fibers using part of the twentanglement method, in combination with multi-particle collision dynamics (MPCD) for the surrounding solvent. Results from simulation will provide considerable guidance in the choice of experiments and in the final analysis of the results from atomic force microscope (AFM) experiments. These experiments will be performed, in parallel with the simulations, in the nanobiophysics (NBP) group.

### PROGRESS

We have reviewed the microrheology techniques used in this field, and gained experience in using the MPCD program central to this part of the project. The simulation code for the calculation of the stress relaxation modulus has been implemented. Initial results for the rheology of concentrated suspensions have been obtained. After discussions with Martin Bennink and Sudhir Hursal of their experimental results for  $\beta$ -lactoglobulin fibrills and bulk rheology data of  $\beta$ -lactoglobulin gels, we have created a model for concentrated fibre suspension and performed some initial simulations of these systems. In addition we have done some analytic calculations for the response of an AFM immersed in a viscoelastic liquid. These should provide an accurate method for the use of an AFM as a rheometer.

### DISSERTATIONS

-

### SCIENTIFIC PUBLICATIONS

1. T.A. Hunt, S. Bernardi and B.D. Todd, A new algorithm for extended nonequilibrium molecular dynamics simulations of mixed flow. *J. Chem. Phys.* 133, 154116 (October 2010).

### PROJECT LEADERS

WJ Briels, ML Bennink (NBP, UT)

### RESEARCH THEME

Complex dynamics of fluids

### PARTICIPANTS

TA Hunt, V Subramaniam (NBP, UT)

### COOPERATIONS

JT Padding (UT & Louvain, B)

### FUNDED

FOM, (Bio-Related Materials network)

University -

FOM 100%

STW -

NWO Other -

Industry -

TNO -

GTI -

EU -

Scholarships -

### START OF THE PROJECT

2010

### INFORMATION

WJ Briels

053 489 2947

w.j.briels@utwente.nl

<http://cbp.tnw.utwente.nl/>

**PROJECT LEADERS**

WJ Briels

**RESEARCH THEME**

Complex dynamics of fluids

**PARTICIPANTS**

A Imperio

**COOPERATIONS**

JT Padding (UT & Leuven, B)

**FUNDED**

EU - nanodirect

University -

FOM -

STW -

NWO Other -

Industry -

TNO -

GTI -

EU 100%

Scholarships -

**START OF THE PROJECT**

2008

**INFORMATION**

WJ Briels

053 489 2947

w.j.briels@utwente.nl

<http://cbp.tnw.utwente.nl/>

**PROJECT AIM**

Particle based simulations are used to study structure formation of colloids in various types of solvents and flows. The solvents to be simulated range from simple Newtonian to strongly shear-thinning visco-elastic fluids. Flows envisaged include stationary and oscillatory shear, and elongational flows. Colloids will range from spheres to rods and plates. Besides flow, the influence of walls will be studied as well.

**PROGRESS**

The friction tensors of spherical and rod-shaped particles confined to microcavities have been calculated. Both flat and cylindrical slits were considered. Hydrodynamic interactions between particle and wall, which were simulated using stochastic rotation dynamics (SRD), cause an overall enhancement of the friction tensor components. The friction enhancements in reasonable approximation scale inversely proportional with the closest distance between the particle and the wall. Currently these frictions are used to analyse experimental data, by evanescent light scattering, of particle dynamics in a slit. In addition to the two publications listed below, one manuscript is accepted and one is under review.

**DISSERTATIONS**

-

**SCIENTIFIC PUBLICATIONS**

1. A. Neild, J.T. Padding, L. Yu, B. Bhaduri, W.J. Briels and T.W. Ng, Translational and rotational coupling in Brownian rods near a solid surface. Phys. Rev. E 82, 041126 (October 2010).





Prof.dr. D Lohse



Prof.dr. A Prosperetti



Prof.dr.ir. L van Wijngaarden

The Physics of Fluids group in Twente works on a variety of aspects in fluid mechanics, in particular on those related to bubbles. The focus of our work is the fundamental understanding of the phenomena of the physics of fluids, bubbles and jets, which we undertake by experimental, numerical and theoretical means. Besides in the J.M.Burgers Center, our research is embedded in the Research Institute of Mechanics, Processes and Control IMPACT, the MESA+ Institute, and the Research Institute for Biomedical Technology BMTi of the University of Twente. The group receives external research funds mainly from FOM, but also from STW, NWO, SenterNovem, EU and several companies. The focus research areas of the group are:

#### **TURBULENCE AND TWO-PHASE FLOW**

Fully developed turbulence is one of the big unsolved problems in fluid dynamics. The main question is the distribution of rare events, which has important implications for, e.g., flight safety. We approach this problem from a fundamental point of view, both experimentally, theoretically, and numerically. One particular important type of turbulence is turbulence (partly) driven by body forces, such as buoyancy. This can happen by either thermally driving the turbulence or also by driving the turbulence through bubbles or dispersed particles. Both will be advected by the flow but also act back on the surrounding liquid (two-way coupling). To be able to describe flow with many bubbles or particles efficiently, one needs an effective force description, on which and with which we work in several projects within our group. Finally, we are also interested in the radial dynamics of single bubbles in hydrodynamic or acoustic fields.

#### **GRANULAR FLOW**

Granular flows are fundamentally different from any other type of flow. In our research we focus on the clustering phenomenon that finds its origin in the inelastic collisions between the particles. There is much emphasis on the onset of clustering, which happens via a phase transition which is studied in both compartmentalized and continuous systems. Another line of our research deals with the impact of objects on very fine, decompactified sand, in which we explore the applicability of fluid models to granular systems. We uncovered links to distant phenomena like asteroid impact and a dry variety of quicksand.

#### **MICRO- AND NANOFUIDICS**

The physics of fluids at the microscale can be quite different from macrofluidic behavior. Here we study disturbing bubbles in microchannels found in ink jet printing. By patterning surfaces on sub-micron scales we try to identify individual 'nanobubbles' which may lead to a quantitative understanding of wall slip. These patterned surfaces may also serve as nucleation sites for cavitation bubbles generated through intense negative pressures.

#### **BIOMEDICAL FLOW**

Bubbles have various applications in the biomedical field. Coated microbubbles are used in ultrasound imaging to enhance the contrast in cardiac or liver perfusion images. Bubbles can be targeted to specific cells for molecular imaging to non-invasively detect the presence and location of diseases such as cancer or atherosclerosis. Furthermore, the bubbles can be exploited to generate acoustic streaming and jetting near cell boundaries which leads to permeation, destruction or removal of target cells.

**PROJECT AIM**

The aim of the project is to understand the dynamics of an impact on liquids, including the resulting void collapse and jet formation. Both experimental and numerical methods are used.

**PROGRESS**

Using a combination of visualization techniques and numerical simulations we showed that the air inside the cavity reaches supersonic speeds just before pinch-off. The results have been published recently (Phys. Rev. Lett. 104, 024501 (2010)). By impacting disks with a harmonic disturbance we further investigated the collapse of non-axisymmetric cavities. An excellent agreement with a linear theory has been found, and non-linear behaviour is studied. The publication about the jet formation has drawn extra attention by a Physicals Review Focus article.

**DISSERTATIONS**

1. S. Gekle Impact on Liquids: Void Collapse and Jet Formation (Nov. 13th, 2009). Cum Laude.

**SCIENTIFIC PUBLICATIONS**

1. S. Gekle, J. M. Gordillo, D. van der Meer and D. Lohse. High-speed jet formation after solid object impact. Phys. Rev. Lett. 102, 034502 (2009).
2. Bergmann, R.P.H.M., Andersen, A., Meer, D. van der & Bohr, T. Bubble Pinch-Off in a Rotating Flow. Phys. Rev. Lett. 102, 204501 (2009).
3. Bolaños-Jiménez, R., Sevilla, A., Martínez-Bazán, C., van der Meer, D., & Gordillo, J. M. The effect of liquid viscosity on bubble pinch-off. Phys. Fluids 21, 072103 (2009).
4. S. Gekle, J. H. Snoeijer, D. Lohse, and D. van der Meer. Approach to universality in axisymmetric bubble pinch-off. Phys. Rev. E. 80, 036305 (2009).
5. R. Bergmann, D. van der Meer, S. Gekle, A. van der Bos, and D. Lohse. Controlled impact of a disk on a water surface: cavity dynamics. J. Fluid Mech. 633, 381-409 (2009).

**PROJECTLEADERS**

D Lohse, D van der Meer

**RESEARCHTHEME**

Complex dynamics of fluids

**PARTICIPANTS**

S Gekle, IR Peters, OR Enríquez, D van der Meer

**COOPERATIONS**

University of Sevilla, Spain

**FUNDED**

University of Twente, FOM	
University	50%
FOM	50%
STW	-
NWO Other	-
Industry	-
TNO	-
GTI	-
EU	-
Scholarships	-

**START OF THE PROJECT**

2006

**INFORMATION**

D van der Meer  
053 489 2387  
d.vandermeer@utwente.nl

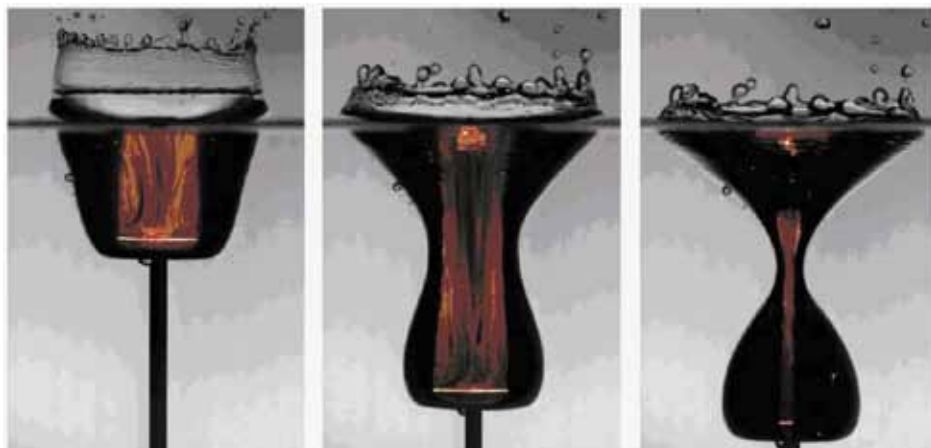

**PROJECT LEADERS**

M Versluis

**RESEARCH THEME**

Complex dynamics of fluids

**PARTICIPANTS**

EC Gelderblom, K Kooiman,  
N de Jong, M Böhmer, D Lohse

**COOPERATIONS**

Erasmus Medical Centre, Philips  
Research

**FUNDED**

EC	
University	-
FOM	-
STW	-
NWO Other	-
Industry	-
TNO	-
GTI	-
EU	100%
Scholarships	-

**START OF THE PROJECT**

2008

**INFORMATION**

E Gelderblom  
053 489 4213  
e.c.gelderblom@utwente.nl

**PROJECT AIM**

Detailed knowledge on the complex dynamics of ultrasound contrast agents has been gained through the use of the Brandaris 128 high speed imaging facility. For visualization of drug release from loaded microbubbles fluorescence imaging is required. However, the nanoseconds timescales at which bubble oscillations, rupture and release take place makes time-resolved fluorescence imaging extremely challenging. The goal of this project is to do ultra high-speed fluorescence imaging of bubble oscillations and drug release at the timescales of bubble oscillations and rupture to gain insight in the mechanisms for local intravenous drug delivery.

**PROGRESS**

An ultra high-speed fluorescence imaging facility was constructed based on the Brandaris 128 high speed imaging system combined with a 5W CW laser (532nm). Oscillations of phospholipid coated microbubbles were recorded with frame rates up to 3 Mfps. These recordings showed phenomena such as dye shedding from the bubble wall and an inhomogeneous dye distribution, which are impossible to see in bright field. Ultra high-speed fluorescence recordings of up to 18 Mfps of oil-filled polymeric microcapsules (Philips Research) with a high dye concentration mixed in the hexadecane liquid core demonstrated a photo-acoustic effect.

**DISSERTATIONS**

-

**SCIENTIFIC PUBLICATIONS**

- Emmer, M., Vos, H.J., Goertz, D.E., Wamel, A. van, Versluis, M., & Jong, N. de. Pressure-Dependent Attenuation and Scattering of Phospholipid-Coated Microbubbles at Low Acoustic Pressures. *Ultrasound in Med. and Biol.* 35, 102-111 (2009).
- Jong, N. de, Emmer, M., Wamel, A. van, & Versluis, M. Ultrasonic characterization of ultrasound contrast agents. *Med Biol Eng Comput* 47, 861-873 (2009).
- Kooiman, K., Böhmer, M.R., Emmer, M., Vos, H.J., Chlon, C., Shi, W.T., Hall, C.S., Winter, S.H. de, Schroën, K., Versluis, M., Jong, N. de, & Wamel, A. van. Oil-filled polymer microcapsules for ultrasound-mediated delivery of lipophilic drugs. *J. Controlled Release* 133, 109-118 (2009).
- Emmer, M., Vos, H., Versluis, M. & Jong, N. de. Radial modulation of single microbubbles. *IEEE Transactions on Ultrasonics, Ferroelectrics, and Frequency Control* 56, 2370-2379 (2009).
- Borsboom, J.M.G., Bouakaz, A., & Jong, N. de. Pulse Subtraction Time Delay Imaging Method for Ultrasound Contrast Agent Detection. *IEEE Transactions on Ultrasonics, Ferroelectrics, and Frequency Control* 56, 1151-1158 (2009).
- Novell, A., Meer, S. van der., Versluis, M., Jong, N. de, Bouakaz, A. Contrast Agent Response to Chirp Reversal: Simulations, Optical Observations, and Acoustical Verification. *IEEE Transactions on Ultrasonics, Ferroelectrics, and Frequency Control* 56, 1199-1206 (2009).
- Zijlstra, A.G., Janssens, T., Wostyn, K., Versluis, M., Mertens, P.M., & Lohse, D. High speed imaging of 1 MHz driven microbubbles in contact with a rigid wall. *Solid State Phenomena* 145-146, 7-10 (2009).

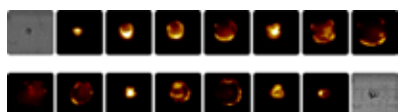

**PROJECT AIM**

Floating particles form clusters on a surface wave in various ways. It is known that the physical properties of the floaters and the wave regime have effects on the clustering. However, it is not fully understood how the particle distribution and their dynamics depend on the particle concentration:

- \* Do the clusters disappear in higher concentrations?
- \* Do the particles move purely at random or do they move cooperatively?

In this study, we would like to answer these questions both by performing experiments and by using statistical analysis borrowed from Lagrangian turbulence and colloidal physics. Our main interest is to understand the variations in the mobility and in the structural properties of the clusters by increasing the concentration and the relevant wave parameters, and in this way, to study physics near the jamming point.

**PROGRESS**

In a first set of experiments we have varied the particle concentration for similar standing wave conditions. For low particle concentrations (left picture), we observe that hydrophobic light particles form very stable clusters at the antinodes. For higher concentrations (right picture), surprisingly, the same particles form clusters at the nodes. The explanation lies in the collective, attractive capillary interaction among particles which counteracts the tendency of the particles to move toward the antinodes. The transition between the two regimes has been studied as a function of the intermediate particle concentration and the transition interval has been determined experimentally.

When the clusters sit more at nodes in the intermediate concentration, the longer time dependent structures has been observed. Using a particle tracking method, the structural differences in the particle clustering have been analyzed by correlating the wave structure and the concentration, and by the pair correlation function. Currently we are analyzing the transition interval in more details, and analyzing longer time series to identify and to distinguish different time regimes.

**DISSERTATIONS**

-

**SCIENTIFIC PUBLICATIONS**

-

**PROJECTLEADERS**

D Lohse, D van der Meer

**RESEARCHTHEME**

Complex dynamics of fluids

**PARTICIPANTS**

C Sanli, D van der Meer, D Lohse

**COOPERATIONS**

-

**FUNDED**

FOM-program Rheophysics:

Connecting Jamming and Rheology

University -

FOM 100%

STW -

NWO Other -

Industry -

TNO -

GTI -

EU -

Scholarships -

**START OF THE PROJECT**

2008

**INFORMATION**

D Lohse

053 489 8076

d.lohse@utwente.nl

[http:// pof.tnw.utwente.nl](http://pof.tnw.utwente.nl)

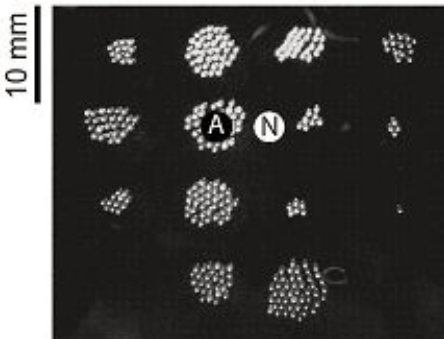

Figure 1: Antinode clusters at low particle concentration on a standing wave.

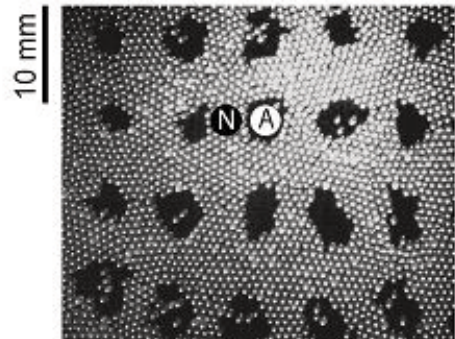

Figure 2: Node clusters at high particle concentration on a standing wave.



**PROJECT LEADERS**

D Lohse

**RESEARCH THEME**

Complex dynamics of fluids

**PARTICIPANTS**

DPM van Gils, C Sun, S Huisman,  
D Lohse

**COOPERATIONS**

TUD: Hydro- & Aerodynamics and  
Kramers Laboratorium, MARIN,  
Spaarnwater

**FUNDED**

STW  
University -  
FOM -  
STW 100%  
NWO Other -  
Industry -  
TNO -  
GTI -  
EU -  
Scholarships -

**START OF THE PROJECT**

2007

**INFORMATION**

D Lohse  
053 489 8076  
d.lohse@utwente.nl  
http:// pof.tnw.utwente.nl

DPM van Gils  
053 489 4682  
d.p.m.vangils@tnw.utwente.nl

**PROJECT AIM**

The overall aim is to find the mechanisms that are responsible for the ship's frictional drag reduction (DR) by air lubrication of the boundary layer flow. The focus lies on the efficiency, persistence, and scaling laws of these mechanisms. One major aim is to study DR in a stationary and stable flow and to this end, the UT has designed a turbulent Taylor-Couette setup (max.  $Re \sim 2 \cdot 10^6$ ) which is operational since July 2009. It will be used to study the behavior of two-phase flow in a boundary layer and the influence of wall characteristics such as roughness and hydrophobicity. This setup with two independently rotating cylinders and bubble injection has the advantage that it allows for statistically stationary flow and accurate resistance measurements by means of the applied torque on the inner rotating drum. Moreover, the bubble distribution in this stationary case will be measured and its effect on the overall torque will be theoretically analyzed. Utilizing a four-point optical fiber probe can give direct experimental proof on the bubble mechanism responsible for DR.

**PROGRESS**

The T3C is taken into operation since July 2009 and the accuracy and stability of all the global parameters like rotation rate, fluid temperature and torque are examined and found to be well controlled. At this moment, an experiment in cooperation with Spaarnwater is in progress to investigate the effects of different foul-release and/or hydrophobic ship coatings to the skin drag in single and two-phase flows. Upcoming experiments will be 1) characterizing the flow profile inside the gap utilizing LDA in the case of co- and counter rotating cylinders, and 2) reproducing with larger accuracy the effect of bubbly induced drag reduction as described in Van den Berg et al., Bubbly Turbulent Drag Reduction Is a Boundary Layer Effect. Phys. Rev. Lett. 98, 084501 (2007). Next the flush mounted shear stress sensors will be worked out.

**DISSERTATIONS**

-

**SCIENTIFIC PUBLICATIONS**

-

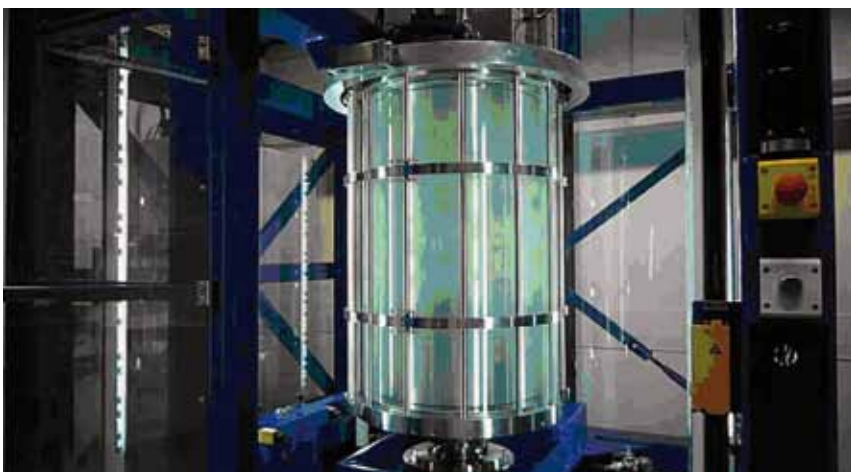

**PROJECT AIM**

Typical actuators using the principle of thermodynamic phase change are slow because diffusion processes rule the dynamics. This project however aims to investigate the possibility to use an explosive thermo-dynamic phase change to generate a force by releasing heat at a large rate, which would make fast actuators possible.

**PROGRESS**

The code developed for performing computations of two phase flow with phase change has been applied to study the dynamics of vapor bubbles in confined geometries. Specifically simulation of vapor bubbles in a cylindrical tube and vapor bubbles between two circular discs have been performed and compared to experiment. The simulation results for the tube geometry correspond well to experimental results and to the 1D model that we developed. For the disc case a model based on the cylindrical Rayleigh-Plesset equation was developed but satisfactory results were not achieved. The code however was more successful in capturing the bubble dynamics. This is due to the bubble shape during its growth and collapse, which was not accounted for in the model but is of crucial importance.

**DISSERTATIONS**

-

**SCIENTIFIC PUBLICATIONS**

1. Sun, C., Can, E., Dijkink, R., Lohse, D. & Prosperetti, A. Growth and collapse of a vapour bubble in a microtube: the role of thermal effects. *J. Fluid Mech.* 632, 5-16 (2009). See also: "Focus on Fluids" by M. Brenner, *J. Fluid Mech.* 632, 1-4 (2009).
2. Zhang, Q. & Prosperetti, A. Pressure-driven flow in a two-dimensional channel with porous walls. *J. Fluid Mech.* 631, 1 - 21 (2009).

**PROJECT LEADERS**

A Prosperetti, D Lohse

**RESEARCH THEME**

Complex dynamics of fluids

**PARTICIPANTS**

E Can, C Sun, D Lohse,  
A Prosperetti

**COOPERATIONS**

Prof. Dr. M. Elwenspoek, University of Twente, Mesa+, University of Twente

**FUNDED**

STW	
University	-
FOM	-
STW	100%
NWO Other	-
Industry	-
TNO	-
GTI	-
EU	-
Scholarships	-

**START OF THE PROJECT**

2006

**INFORMATION**

A Prosperetti  
053 489 3086  
a.prosperetti@tnw.utwente.nl

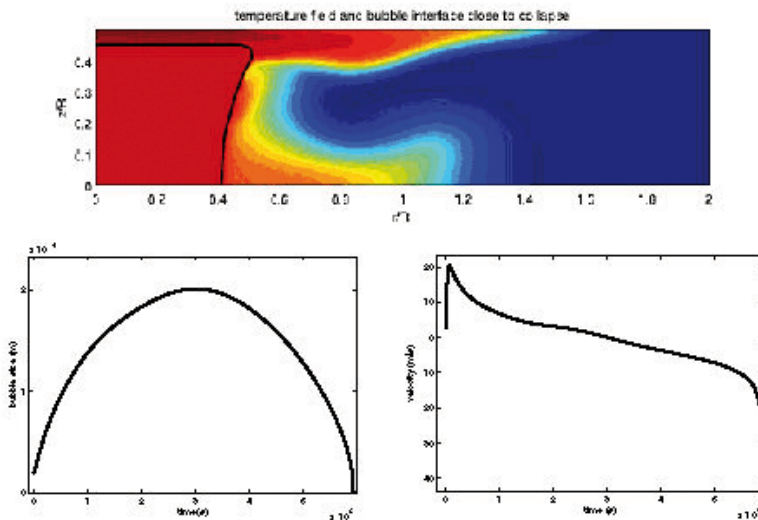

**PROJECT LEADERS**

D Lohse

**RESEARCH THEME**

Complex dynamics of fluids

**PARTICIPANTS**

BM Borkent, S Das, H Gelderblom,  
JRT Seddon, JH Weijs, W Walczyk,  
JH Snoeijer, L van Wijngaarden,  
D Lohse

**COOPERATIONS**

Chair Solid State Physics  
University of Twente (S. Caynak,  
MSc. O. Bliznyuk, Dr. E.S. Kooij,  
Prof. Dr. Ir. H.J.W. Zandvliet, Prof.  
Dr. Ir. B. Poelsema)  
University of Siegen (Dr. H.  
Schönherr), Institut de Physique de  
Rennes (G. Le Caër, B. Dollet)  
Harvard University (Prof. Dr. M.P.  
Brenner)

**FUNDED**

FOM, STW-Nanoned, EU University	-
FOM	35%
STW	35%
NWO Other	-
Industry	-
TNO	-
GTI	-
EU	30%
Scholarships	-

**START OF THE PROJECT**

2003 (STW)  
2009 (FOM, EU, university)

**INFORMATION**

D Lohse  
053 489 8076  
d.lohse@utwente.nl  
www.pof.tnw.utwente.nl

**PROJECT AIM**

Immersing hydrophobic substrates in water leads to the surprising formation of nanoscopic bubbles adhered to the substrate. Several fundamental questions exist, for example: Why do surface nanobubbles not disappear through diffusion, how do they form, and how are they affected by substrate topography? To answer these questions, we employ experimental (including atomic force microscopy), numerical (including molecular dynamics), and theoretical methods. The ultimate aims of this research are to understand the behaviour of gas-liquid-substrate interactions at the nanoscale, as well as to control slip in nano/micro-fluidic devices.

**PROGRESS**

AFM experiments revealed that the volume of the nanobubbles formed increases with gas concentration and liquid temperature. Contamination increases the contact angle of surface nanobubbles; in a relatively clean experiment the contact angle is closer to its macroscopic value. Nanobubbles form in a structured way, with a preferred radius and spacing between individual bubbles. An analytical model of diffusion in a potential field is used to investigate whether a potential gradient can lead to a gas influx at the contact line large enough to balance to the diffusive gas outflux, and stabilize the bubble. Preliminary MD simulations indicate that such a gas influx at the contact line can occur. Additionally, a theoretical study on the influence of surfactants on nanobubble stability is performed.

**DISSERTATIONS**

1. PhD thesis: Interfacial phenomena in micro- and nanofluidics: nanobubbles, cavitation, and wetting. B. M. Borkent, October 2, 2009. Cum Laude.
2. MSc thesis: Characterization of surface nanobubbles by means of atomic force microscopy. W. Walczyk, August 14, 2009.

**SCIENTIFIC PUBLICATIONS**

1. Borkent, B.M., Schönherr, H., Le Caër G., Dollet, B. & Lohse, D. Preferred sizes and ordering in surface nanobubble populations. *Phys. Rev. E* 80, 036315 (2009).
2. Borkent, B.M., Gekle, S., Prosperetti, A., & Lohse, D. Nucleation threshold and deactivation mechanisms of nanoscopic cavitation nuclei. *Phys. Fluids* 21, 102003 (2009).
3. Heijnen, G.L., Quinto-Su, P.A., Zhao, X., & Ohl, C.D. Cavitation within a droplet. *Phys. Fluids* 21, 091102 (2009). Winning entry from the 26th Annual Gallery of Fluid Motion 2009.
4. Yang, S., Tsai, P., Kooij, E.S., Prosperetti, A., Zandvliet, H.J.W., & Lohse, D. Electrolytically Generated Nanobubbles on Highly Orientated Pyrolytic Graphite Surfaces *Langmuir* 25, (3) 1466–1474 (2009).

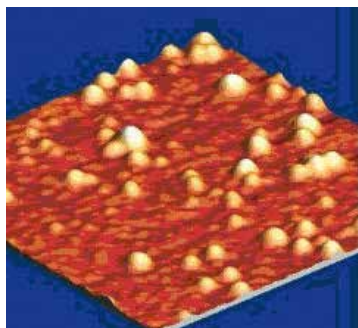

**PROJECT AIM**

Static granular matter is traditionally studied in terms of contact forces between the particles only. Recent experimental evidence shows that this framework is insufficient to describe loosely packed fine granular matter: The influence of the interstitial air needs to be taken into account. This influence becomes particularly strong where the contact forces between the grains become vanishingly small, i.e., close to the jamming point. The objective of this project is to study in detail how the ambient, interstitial air influences the structure of loosely packed, static granular matter close to the jamming point.

**PROGRESS**

In one of the first experiments the pressure difference over and the air flow through the sand bed is measured during the events caused by an impacting ball: splash and penetration, jet formation, and granular eruption. The experiments are done at different container pressures and different release heights.

**DISSERTATIONS**

-

**SCIENTIFIC PUBLICATIONS**

1. Lohse, D. & Meer, D. van der. Granular media: Structures in sand streams Nature 459, 1064-1065 (2009).

**PROJECTLEADERS**

D van der Meer, MA van der Hoef,  
JAM Kuipers, D Lohse

**RESEARCHTHEME**

Complex dynamics of fluids

**PARTICIPANTS**

Tess Homan

**COOPERATIONS**

-

**FUNDED**

FOM	
University	-
FOM	100%
STW	-
NWO Other	-
Industry	-
TNO	-
GTI	-
EU	-
Scholarships	-

**START OF THE PROJECT**

2009

**INFORMATION**

T Homan  
053 489 4473  
t.a.m.homan@utwente.nl  
<http://pof.tnw.utwente.nl/>

**PROJECT LEADERS**

D Lohse

**RESEARCH THEME**

Complex dynamics of fluids

**PARTICIPANTS**

RJAM Stevens, D Lohse

**COOPERATIONS**

Prof. Dr. H.J.H. Clercx (Eindhoven, Netherlands), Prof. Dr. G.J.F. van Heijst (Eindhoven, Netherlands), Dr. J.Q. Zhong (Santa Barbara, USA), Prof. Dr. G. Ahlers (Santa Barbara, USA), Prof. Dr. R. Verzicco (Tor Vergata, Italy)

**FUNDED**

FOM  
 University -  
 FOM 100%  
 STW -  
 NWO Other -  
 Industry -  
 TNO -  
 GTI -  
 EU -  
 Scholarships -

**START OF THE PROJECT**

2008

**INFORMATION**

D Lohse  
 053 489 8076  
 d.lohse@utwente.nl;  
 http:// pof.tnw.utwente.nl

RJAM Stevens  
 053 489 4682  
 r.j.a.m.stevens@tnw.utwente.nl

**PROJECT AIM**

Turbulent convection under rotation about a vertical axis is a simple model system for industrial and geophysical systems. Examples include flow in the atmosphere, oceans, the inner core of the earth, giant gas planets and the outer layer of the sun. The aim of this research project is to investigate the effect of background rotation on Rayleigh-Bénard convection. With a cylindrical Rayleigh-Bénard cell, which is placed on a rotating table, we can accurately measure the heat transport in the system. These measurements are supplemented by numerical studies which give full access to the full flow domain to study changes in the flow structure.

**PROGRESS**

The experimental measurements and the results from direct numerical simulations (DNS) show that the heat transport in the system can increase up to 30 % due to rotation. This increased heat transfer is due to Ekman-pumping, i.e. rising and falling plumes of hot and cold fluid are stretched into vertical vortices that suck fluid out of the thermal boundary layers adjacent to the bottom and top plates. There is an optimal Pr number (with fixed Ra and Ro) for the heat transport enhancement, see figure 1, because the efficiency of Ekman pumping is limited for high and low Pr. For low Pr the efficiency is limited by the large thermal diffusivity, i.e. the heat that is sucked out of the thermal BL spreads out horizontally. For high Pr the efficiency is limited because the temperature of the fluid that is sucked out of the thermal BLs is relatively low.

**DISSERTATIONS**

-

**SCIENTIFIC PUBLICATIONS**

1. Zhong, J.Q., Stevens, R.J.A.M., Clercx, H.J.H., Verzicco, R., Lohse, D., & Ahlers, G. Prandtl-, Rayleigh-, and Rossby-Number Dependence of Heat Transport in Turbulent Rotating Rayleigh-Bénard Convection. Phys. Rev. Lett. 102, 044502 (2009). See also the cover of that issue.
2. Stevens, R.J.A.M., Zhong, J.Q. Clercx, H.J.H., Ahlers, G., & Lohse, D. Transitions between turbulent states in rotating Rayleigh-Bénard convection. Phys. Rev. Lett. 103, 024503 (2009).
3. Stevens, R.J.A.M., Clercx, H.J.H., Lohse, D. Optimal Prandtl number for heat transfer in rotating Rayleigh-Bénard convection. Submitted to NJP, see arXiv:0912.0816 (2009).

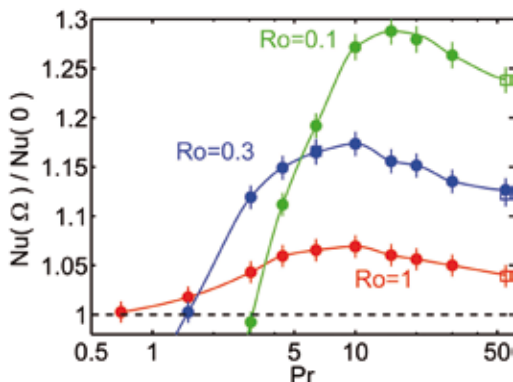

Normalized heat transfer as function of Pr for Ra = 10<sup>8</sup> and different Ro [3].

**PROJECT AIM**

We develop model systems for shear thickening suspensions and probe their rheology and configurational changes close to the vibration-induced jamming point. The work is motivated by recent work describing the formation of persistent holes and finger like protrusions in thin layers of cornstarch that are shaken at high accelerations. These phenomena must be connected to the shear-thickening properties of the cornstarch and a change from a fluid to a more solid-like, jammed state, as it is unknown what mechanism causes these shapes. In a first series of experiments, a layer of cornstarch will be vibro-fluidized using a shaker. The experiment will be repeated in an index-matched suspension of micron-sized glass spheres (diameter 10-50µm) allowing us to also measure the microscopic properties of the fluid.

**PROGRESS**

Experiments where mixtures of water and cornstarch/glass beads were done. For cornstarch we explored the effects of shaking strength, frequency, layer depth and concentration and the different kinds of distortions were mapped into a phase diagram. For glass beads preliminary experiments structures were found to be less stable. A 2nd direction was initiated in which we are studying the impact and sedimentation of a metal sphere into a shear thickening liquid bed. In these experiments we find that the sphere approaches the bottom in an oscillatory way which we believe to be caused by the shear thickening behavior of the liquid.

**DISSERTATIONS**

-

**SCIENTIFIC PUBLICATIONS**

-

**PROJECTLEADERS**

D Lohse, D van der Meer

**RESEARCHTHEME**

Complex dynamics of fluids

**PARTICIPANTS**

D van der Meer, S von Kann, J Snoeijer

**COOPERATIONS**

Part of FOM programme:  
Rheophysics: Connecting jamming and rheology

**FUNDED**

FOM	
University	-
FOM	100%
STW	-
NWO Other	-
Industry	-
TNO	-
GTI	-
EU	-
Scholarships	-

**START OF THE PROJECT**

2008

**INFORMATION**

S von Kann  
s.vonkann@tnw.utwente.nl  
<http://pof.tnw.utwente.nl>



Formation of persistent holes and finger like protrusions in thin layers of cornstarch that are shaken at high accelerations.

**PROJECT LEADERS**

M Versluis

**RESEARCH THEME**

Complex dynamics of fluids

**PARTICIPANTS**

B Verhaagen, L Heijnen

**COOPERATIONS**

L van der Sluis, L Jiang (Academic Center for Dentistry, Amsterdam, Netherlands), C Boutsoukis (Dental School, Aristotle University, Thessaloniki, Greece)

**FUNDED**

STW  
 University -  
 FOM -  
 STW 100%  
 NWO Other -  
 Industry -  
 TNO -  
 GTI -  
 EU -  
 Scholarships -

**START OF THE PROJECT**

2007

**INFORMATION**

M Versluis  
 053 489 6824  
 m.versluis@utwnete.nl

B Verhaagen  
 053 489 3084  
 b.verhaagen@tnw.utwente.nl

**PROJECT AIM**

Ultrasonic irrigation of the root canal is found to be much more efficient than conventional root canal irrigation using a syringe, in which bacteria often remain, leading to re-infection. Why ultrasonic irrigation is more effective is not known, however. Through experiments and numerical simulations we try to elucidate the cleaning mechanisms (streaming, cavitation, or other mechanisms) involved in root canal cleaning, with the final goal of improving root canal irrigation even more.

**PROGRESS**

A computational model (developed by Christos Boutsoukis, Aristotle University of Thessaloniki, Greece) of flow from a needle in a root canal has been validated with high-speed PIV. The results from this study (flow velocity, replacement efficiency, shear stress, pressure) and other studies using the CFD model will be published soon. Meanwhile, work has been done on the measurement of the pressure developed during irrigation of the root canal. Also, studies on different aspects (e.g. different driving frequencies) of ultrasonic irrigation have been started and recently a master student has started his work on the influence of particles added to the ultrasonically activated fluid.

**DISSERTATIONS**

-

**SCIENTIFIC PUBLICATIONS**

1. S.D. de Groot, B. Verhaagen, M. Versluis, M.-K. Wu, P.R. Wesselink, & L.W.M. van der Sluis. Laser-activated irrigation within root canals: cleaning efficacy and flow visualization. *Int. Endod. J.* 42, 1077-1083 (2009).

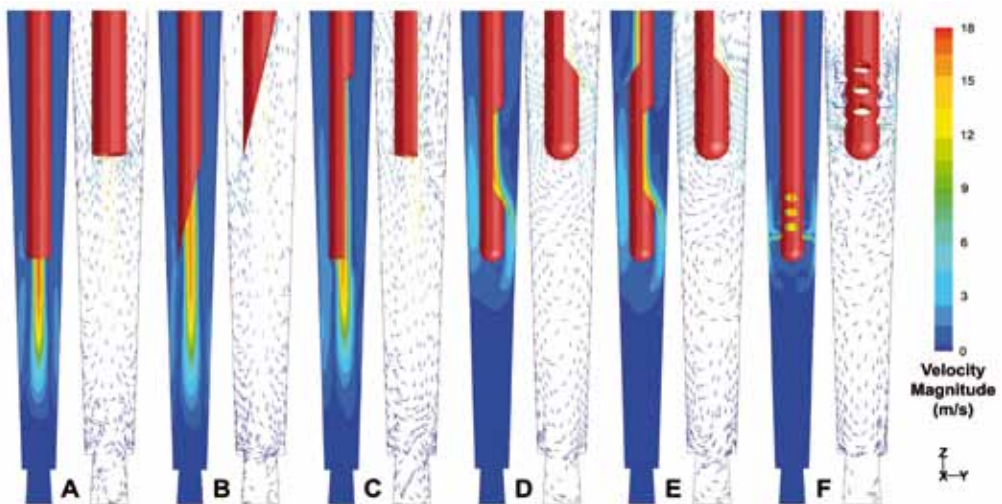

**PROJECT AIM**

The aim of the project is to gain understanding in the physical mechanism of ultrasonic cleaning with particular interest for the removal of nano sized particles from silicon wafers as is commonly applied in semiconductor industry.

**PROGRESS**

The previous set of experiments have revealed a particular type of cavitation bubble dynamics which results in the removal of nanoparticles due to strong focussing of fluid motion towards the boundary. Due to the notorious uncontrollability of cavitation these experiments are very difficult to reproduce which prompted the development of an improved setup to address this issue. This setup enables control over both gas content and the sound field. In addition, the controlled generation of bubbles needed for cleaning is required and investigated. Here, a new phenomenon where microbubbles are continuously generated from micropits was discovered (see image). A theoretical and experimental study is underway to quantify the hydrodynamic force required to dislodge a nano-particle from a substrate.

**DISSERTATIONS**

-

**SCIENTIFIC PUBLICATIONS**

1. S. Brems, M. Hauptmann, E. Camerotto, A. Pacco, S. Halder, A.G. Zijlstra, G. Doumen, T. Bearda, P.M. Mertens. Impact of Acoustical Reflections on Megasonic Cleaning Performance ECS Transactions, 25 (5) 287-294 (2009).
2. Zijlstra, A.G., Janssens, T., Wostyn, K., Versluis, M., Mertens, P.M., & Lohse, D. High speed imaging of 1 MHz driven microbubbles in contact with a rigid wall. Solid State Phenomena 145-146, 7-10 (2009).

**PROJECTLEADERS**

M Versluis, D Lohse, P Mertens

**RESEARCHTHEME**

Complex dynamics of fluids

**PARTICIPANTS**

AG Zijlstra, M Versluis, PM Mertens, S Brems, D Fernandez Rivas

**COOPERATIONS**

IMEC, Leuven Belgium

**FUNDED**

IMEC, Leuven Belgium	
University	-
FOM	-
STW	-
NWO Other	-
Industry	100%
TNO	-
GTI	-
EU	-
Scholarships	-

**START OF THE PROJECT**

2007

**INFORMATION**

A Zijlstra  
053 489 4213  
a.g.zijlstra@tnw.utwente.nl

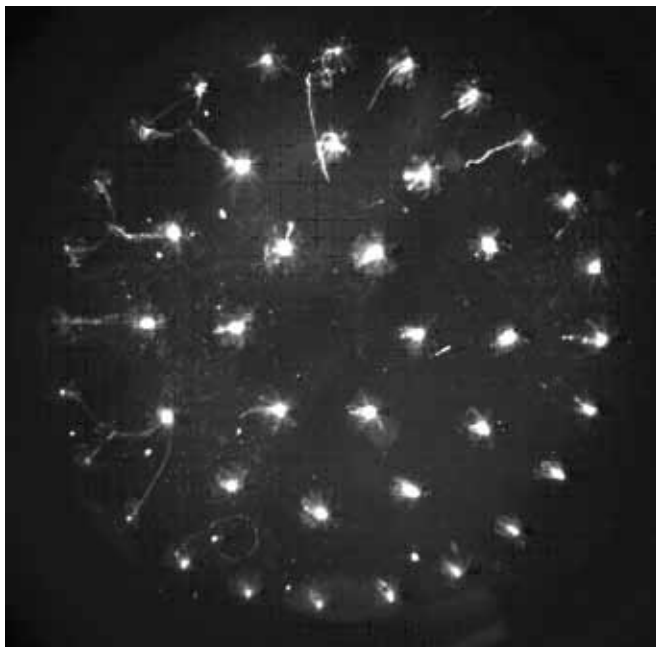

Generation of microbubbles by an array of micropits ( $r=10$ ) in a 200 kHz acoustic field.



**PROJECT LEADERS**

M Versluis, N de Jong, D Lohse

**RESEARCH THEME**

Complex dynamics of fluids

**PARTICIPANTS**

M Overvelde, V Garbin, T Hay,  
B Dollet, J Sijl, N de Jong, D Lohse,  
M Versluis

**COOPERATIONS**

Bracco Research S.A., Biomedical  
Engineering Erasmus MC

**FUNDED**

University -  
FOM -  
STW -  
NWO Other -  
Industry -  
TNO -  
GTI -  
EU -  
Scholarships -

**START OF THE PROJECT**

-

**INFORMATION**

M Versluis  
053 489 6824  
m.versluis@utwente.nl

**PROJECT AIM**

Molecular imaging with ultrasound is a promising non-invasive technique for disease-specific imaging, enabling for instance the diagnosis of thrombus and inflammation. Selective imaging is performed by using ultrasound contrast agents containing ligands on their shell, which bind specifically to the target molecules. To improve molecular imaging diagnosis with ultrasound one would be able to distinguish adherent microbubbles from freely circulating ones. The simplest approach is to wash-out all the freely circulating microbubbles and image the remaining bubbles. The disadvantage is that it takes 5 to 10 minutes before all freely circulating bubbles are cleared by the liver and that there is no new supply of bubbles. Therefore it would be beneficial to distinguish acoustically between adherent and freely circulating microbubbles.

**PROGRESS**

We investigated the influence of targeting on the dynamics of the microbubbles, in particular on the frequency of maximum response, by recording the radial response of individual microbubbles as a function of the applied acoustic pressure and frequency. The frequency of maximum response of adherent microbubbles was found to be over 50% lower than for bubbles in the unbounded fluid and over 30% lower than that of a bubble in contact with the wall. The change is caused by adhesion of the bubbles to the wall as no influence was found solely by the presence of the targeting ligands on the bubble dynamics. The shift in the frequency of maximum response may prove to be important for molecular imaging applications with ultrasound as these applications would benefit from an acoustic imaging method to distinguish adherent from freely circulating microbubbles.

**DISSERTATIONS**

1. Sijl, J. (2009, December, 16). "Ultrasound contrast agents - optical and acoustical characterization", University of Twente, (Enschede, The Netherlands: Physics of Fluids group). Promotoren: Prof. dr. D. Lohse and Prof. dr. ir. N. de Jong.

**SCIENTIFIC PUBLICATIONS**

1. Valeria Garbin, Benjamin Dollet, Marlies Overvelde, Dan Cojoc, Enzo Di Fabrizio, Leen van Wijngaarden, Andrea Prosperetti, Nico de Jong, D Lohse, Michel Versluis. History force on coated microbubbles propelled by ultrasound. *Physics of Fluids*, 21(9) 092003. (2009).
2. Mie scattering distinguishes the topological charge of an optical vortex: a homage to Gustav Mie. Valeria Garbin, Giovanni Volpe, Enrico Ferrari, Michel Versluis, Dan Cojoc and Dmitri Petrov. *New J. Phys* 11, 013046 (2009).
3. Emmer, M., Vos, H., Versluis, M. & Jong, N. De. Radial modulation of single microbubbles. *IEEE Transactions on Ultrasonics, Ferroelectrics, and Frequency Control* 56, 2370-2379 (2009).

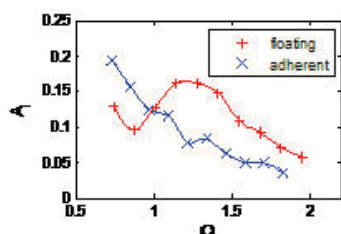

Resonance curves of a phospholipid-coated bubble floating against the wall (red) and adherent to the wall (blue) insonified with a pressure Pa = 100 kPa.

**PROJECT AIM**

One of the major goals in research on granular matter is to achieve some granular hydrodynamic description. In many situations such a description works, however, in others it breaks down. The origin of the breakdown of the granular hydrodynamic approach is the clustering. Therefore the aim of the project is to analyze the system properties at the phase transition towards clustering in detail.

**PROGRESS**

We could first experimentally explore and then theoretically understand (by linear stability analysis) the phase diagram of shaken granular matter for large aspect ratios. For this geometry the continuum approach works excellently. We moreover have experimentally realized a granular ratchet and described its characteristics.

**DISSERTATIONS**

-

**SCIENTIFIC PUBLICATIONS**

1. Gerner, H.J. van, Caballero Robledo, G.A., Meer, D. van der, Weele, K. van der, & Hoef, M.A. van der. Coarsening of Faraday Heaps: Experiment, Simulation, and Theory. Phys. Rev. Lett. 103, 028001 (2009).
2. Weele, K. van der, Kanellopoulos, G., Tsiavos, C. & Meer, D. van der. Transient granular shock waves and upstream motion on a staircase. Phys. Rev. E 80, 011305 (2009).
3. Eshuis, P., Weele, K. van der, Calzavarini, E., Lohse, D. & Meer, D. van der. Exploring the limits of granular hydrodynamics: A horizontal array of inelastic particles. Phys. Rev. E 80, 011302 (2009).
4. Weele, K. van der, Kanellopoulos, G., Tsiavos, C. & Meer, D. van der. Transient granular shock waves and upstream motion on a staircase. Phys. Rev. E 80, 011305 (2009).
5. H.J. van Gerner, K. van der Weele, M.A. van der Hoef, and D. van der Meer, "Air-induced inverse Chladni patterns", to be submitted to J. Fluid Mech. (2009).
6. H.J. van Gerner, M.A. van der Hoef, D. van der Meer, and K. van der Weele, "Gravity-induced inverse Chladni patterns", to be submitted to Phys. Rev. E (2009).

**PROJECT LEADERS**

D Lohse, D van der Meer

**RESEARCH THEME**

Complex dynamics of fluids

**PARTICIPANTS**

D Lohse, K van der Weele, D van der Meer, PG Eshuis

**COOPERATIONS**

Prof. Dr. S. Luding, UT, Prof. M. Alam, Bangalore, Prof. J.A.M. Kuipers, UT, Dr. Martin van der Hoef, UT

**FUNDED**

FOM-program Physics of Granular Matter (03PGM02)

University	-
FOM	100%
STW	-
NWO Other	-
Industry	-
TNO	-
GTI	-
EU	-
Scholarships	-

**START OF THE PROJECT**

2003

**INFORMATION**

D Lohse  
053 489 8076  
d.lohse@utwente.nl  
<http://pof.tnw.utwente.nl>

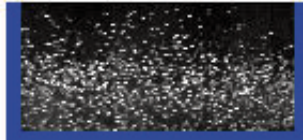
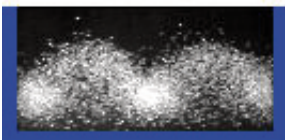

**PROJECT LEADERS**

D Lohse

**RESEARCH THEME**

Complex dynamics of fluids

**PARTICIPANTS**

D Lohse, RJAM Stevens

**COOPERATIONS**

Prof. S. Grossmann, University of Marburg, Germany, Prof. G. Ahlers, University of California at Santa Barbara, United States, Prof. K.Q. Xia, The Chinese University of Hong Kong, Shatin

**FUNDED**

FOM Programme on Turbulence

University	-
FOM	100%
STW	-
NWO Other	-
Industry	-
TNO	-
GTI	-
EU	-
Scholarships	-

**START OF THE PROJECT**

2003

**INFORMATION**

D Lohse

053 489 8076

d.lohse@utwente.nl

http://pof.tnw.utwente.nl

**PROJECT AIM**

The three aims of the project "High Rayleigh number thermal convection" are:

1. To investigate the irregular reversals of the large-scale circulation (the so called "wind" of turbulence).
2. To extend Grossmann-Lohse theory to non-Boussinesq effects on the heat flux, different geometries (aspect-ratio dependence), and boundary conditions (rough walls).
3. To check the theory against experimental and numerical data.

**PROGRESS**

The main focus of the last year was on Non-Oberbeck-Boussinesq effects, which we explored both experimentally (in collaboration with G. Ahlers), theoretically, and numerically.

**DISSERTATIONS**

-

**SCIENTIFIC PUBLICATIONS**

1. Ahlers, G., Grossmann, S., & Lohse, D. Heat transfer and large scale dynamics in turbulent Rayleigh-Bénard convection. *Rev. of Mod. Phys.* 81, 503-538 (2009).
2. Stevens, R.J.A.M., Zhong, J.Q., Clercx, H.J.H., Ahlers, G. & Lohse, D. Transitions between Turbulent States in Rotating Rayleigh-Bénard Convection. *Phys. Rev. Lett.* 103, 024503 (2009).
3. Zhong, J.Q., Stevens, R.J.A.M., Clercx, H.J.H., Verzicco, R., Lohse, D., & Ahlers, G. Prandtl-, Rayleigh-, and Rossby-Number Dependence of Heat Transport in Turbulent Rotating Rayleigh-Bénard Convection. *Phys. Rev. Lett.* 102, 044502 (2009). See also the cover of that issue.
4. Sugiyama, K., Calzavarini, E., Grossmann, S., & Lohse, D. Flow organization in two-dimensional non-Oberbeck-Boussinesq Rayleigh-Bénard convection in water. *J. Fluid Mech.* 637, 105-135 (2009).
5. Oresta, P., Verzicco, R., Lohse, D., & Prosperetti, A. Heat transfer mechanisms in bubbly Rayleigh-Bénard convection. *Phys. Rev. E* 80, 026304 (2009).

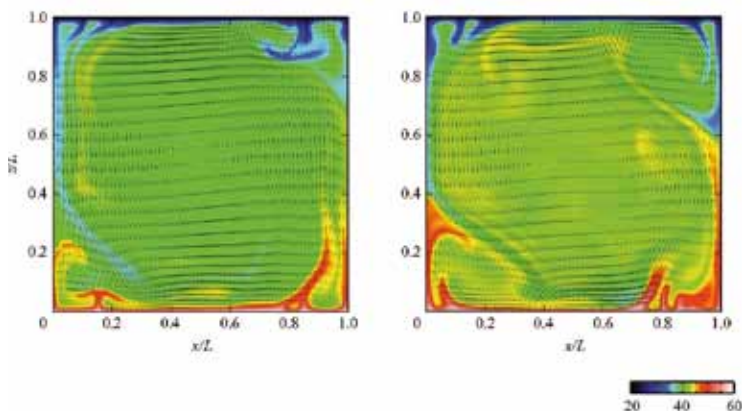

Snapshots of the velocity (arrows) and temperature (colour) fields for  $Ra = 10^8$  at  $T_m = 40^\circ\text{C}$ , working fluid water, (a) corresponds to the OB case (all material properties are kept temperature independent, taken at  $T_m$ ), (b) corresponds to the NOB case, both with the same  $\Delta = 40\text{K}$ . The temperature colour scheme is in degrees C, same in both panels.

**PROJECT AIM**

This project will emphasize on improvement of the energy efficiency sonochemical reactors by at least one order of magnitude by miniaturizing reactors to gain full control over the cavitation process and all its energetic aspects. Improvement of the energy efficiency by one order of magnitude will make the energy consumption of the process equivalent to the energy consumption of a conventional industrial stirred tank reactor, which will make sonochemical microreactors feasible. The major objective of the project is to design, develop and test energy efficient sonochemical microreactors.

**PROGRESS**

We achieved stable hydrodynamic cavitation in a microchannel. No conversion of the oxidation of phenol and potassium iodide using a hydrodynamic cavitation microchip has been measured. Surface controlled cavitation experiments have been reproduced. No conversion of potassium iodide in controlled surface cavitation events has been measured. An ODE model simulating dynamics and radical production was developed and further extended by inclusion of heat and mass transport. Considering the crucial role of temperature in chemical production, a PDE model for the temperature field inside the bubble has been developed in order to investigate the limits of applicability of the ODE model.

**DISSERTATIONS**

-

**SCIENTIFIC PUBLICATIONS**

-

**PROJECTLEADERS**

D Lohse

**RESEARCHTHEME**

Mathematical and computational methods for fluid flow analysis

**PARTICIPANTS**

L Stricker, A Prosperetti, C Sun

**COOPERATIONS**

TU Eindhoven Prof. Dr. J.T.F. Keurentjes, UT, Prof. Dr. J.G.E. Gardeniers, Ir. J. Rooze, D. Fernandez Rivas

**FUNDED**

STW	
University	-
FOM	-
STW	100%
NWO Other	-
Industry	-
TNO	-
GTI	-
EU	-
Scholarships	-

**START OF THE PROJECT**

2009

**INFORMATION**

D Lohse  
053 489 8076  
d.lohse@utwente.nl  
[http:// pof.tnw.utwente.nl](http://pof.tnw.utwente.nl)

**PROJECT LEADERS**

D Lohse

**RESEARCH THEME**

Complex dynamics of fluids

**PARTICIPANTS**

P Tsai, D Lohse

**COOPERATIONS**

Chair Membrane Technology, University of Twente (Dr. A. Peters, Dr. R. Lammertink, Prof. Dr. M. Wessling), Chair Catalytic Systems & Micro Devices (Prof. dr. L. Lefferts)

**FUNDED**

University Spearhead programme,

University 100%

FOM -

STW -

NWO Other -

Industry -

TNO -

GTI -

EU -

Scholarships -

**START OF THE PROJECT**

2009

**INFORMATION**

D Lohse

053 489 8076

d.lohse@utwente.nl

http:// pof.tnw.utwente.nl

**PROJECT AIM**

Hydrophobic microstructures can exhibit superhydrophobic behavior with effective contact angles of 160° and even beyond. The Cassie's law describes such a state of composite wetting: an effective contact angle for the droplet is determined by surface heterogeneities, i.e. surface posts alternating with air pockets trapped below the droplet. In some cases, this superhydrophobicity can break down. After some initial infiltration the fluid can spread and the droplet impregnates through the microstructure, resulting into the smaller contact angle of the so-called "Wenzel state". In addition, a natural evaporating process can trigger this heterogenous to homogenous wetting transition. The project aims include 1) accurate measurements of the critical droplet size, 2) the water penetration dynamics, and 3) the physical mechanism of the Cassie-Baxter to Wenzel wetting transition triggered by evaporation.

**PROGRESS**

We have experimentally investigated the wetting transition from a Cassie-Baxter to a Wenzel state triggered by evaporation. An initially mm-sized water droplet can undergo the transition upon hydrophobic microstructures as the droplet evaporates down to a few hundred of microns in diameter. The transition point was determined by the bottom views using a high-speed camera (see Figure 1) when water starts to invade into the microstructures, marked by the dark areas in Figure 1. The long-time dynamics of the droplet shape was filmed at about 1 fps (Figure 2) to obtain the contact angle dynamics. The apparent contact angle was observed to be decreasing, with a slow (steep) decrease for the Cassie-Baxter (Wenzel) state, and the infiltration dynamics at this transition was studied. A theoretical model was established to estimate the surface energies for both a pure Cassie-Baxter and a pure Wenzel state. We found that a Cassie-Baxter droplet costs less surface energy initially and as evaporation goes on a Wenzel droplet is favored based on the surface energy argument.

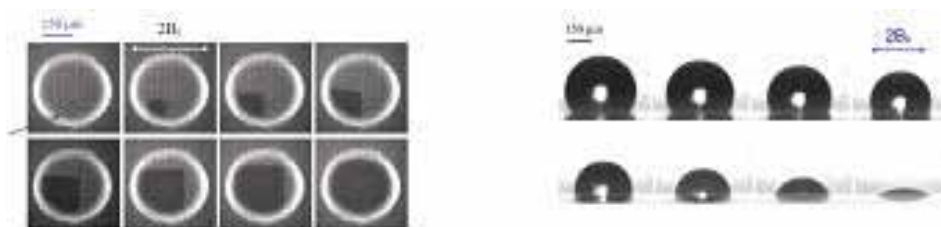

Snapshots of the bottom-view reveal the water infiltration dynamics at the transition from a Cassie-Baxter to a Wenzel wetting state triggered by evaporation. Here, the square lattice have the dimension with  $a = 5, w = 5$ , and  $h = 10 \mu\text{m}$ . The dark areas indicate the water imbibition, while the air pockets present in the bright areas enclosed by a rather bright circumference marked by the droplet base. These images are sequentially recorded at  $t = 0, 30, 58, 72, 116, 180, 236$  and  $310$  ms from the transitional point, determined by the first frame where a small initial infiltration point is observed (marked by an arrow). Figure 2: Snapshots of the side-views of an evaporating droplet with the time interval 15 s between the images, revealing the decrease of the contact angle. The dash lines, marking the drop base, separate the main droplet from its mirror image. The arrow shows the length scale of the critical diameter  $2B_c$  at the wetting transition, determined from the bottom views.

## DISSERTATIONS

-

## SCIENTIFIC PUBLICATIONS

1. Tsai, P., Peters, A.M., Pirat, C., Wessling, M., Lammertink, R.G.H., & Lohse, D. Quantifying effective slip length over micropatterned hydrophobic surfaces. *Phys. Fluids* 21, 112002 (2009).
2. Tsai, P., Pacheco, S., Pirat, C., Lefferts, L. & Lohse, D. Drop Impact upon Micro- and Nanostructured Superhydrophobic Surfaces. *Langmuir* 25, (20) 12293-12298 (2009). See also cover of that issue.
3. Yang, S., Tsai, P., Kooij, E.S., Prosperetti, A., Zandvliet, H.J.W., & Lohse, D. Electrolytically Generated Nanobubbles on Highly Orientated Pyrolytic Graphite Surfaces *Langmuir* 25, (3) 1466–1474 (2009).
4. Peters, A.M., Pirat, C., Sbragaglia, M., Borkent, B.M., Wessling, M., Lohse, D. & Lammertink, R.G.H. Cassie-Baxter to Wenzel state wetting transition: Scaling of the front velocity. *Eur. Phys. J. E* 29, 391–397 (2009).

# NON INVASIVE MOLECULAR TUMOR IMAGING AND KILLING (NIMTIK)

## PROJECT LEADERS

M Versluis, T van Leeuwen

## RESEARCH THEME

Complex dynamics of fluids

## PARTICIPANTS

J Sijl, S Manohar, M Versluis,  
T van Leeuwen, N de Jong, D Lohse

## COOPERATIONS

Biophysical Engineering, University  
of Twente; Erasmus Medical Center

## FUNDED

BMTI Portfolio, University of Twente	
University	100%
FOM	-
STW	-
NWO Other	-
Industry	-
TNO	-
GTI	-
EU	-
Scholarships	-

## START OF THE PROJECT

2004

## INFORMATION

M Versluis  
053 489 6824  
m.versluis@tnw.utwente.nl

## PROJECT AIM

Here we focus on the development of a non-invasive method for early detection of tumors. By attaching specific bio-chemical target markers to microbubbles or by labeling antibodies to cancer cells the transport can be directed. Also the target site can be visualized using ultrasound imaging. This may eventually lead to an increased detection rate of tumors or e.g. thrombosis. We also work on the eradication of localized tumors. In addition to the ultrasound techniques applied in our group the NIMTIK project also includes molecular imaging in the field of photo-acoustics and optical tomography. The synthesis of contrast particles for these techniques is under the guidance of the polymer chemists, while the optimization and signal analysis for each detection method is the task of the electrical engineers.

## PROGRESS

We have used the Brandaris ultrahigh-speed camera to investigate the radial dynamics of differently sized phospholipid coated microbubbles optically. In this experimental study we have varied both the driving pressure amplitude and frequency to investigate the dependence of the non-linear subharmonic and "compression-only" behavior of phospholipid coated microbubbles on the oscillation amplitude of the bubble wall. From the comparison between the experimental results and the numerical simulations we found that the initial surface tension of the bubble determines both its subharmonic and its "compression-only" behavior. These findings are valuable for the application of phospholipid coated microbubbles in medical ultrasound imaging. By controlling the initial conditions of the microbubbles, their non-linear/subharmonic behavior can be enhanced leading to an improved contrast to tissue ratio in contrast-enhanced ultrasound imaging.

## DISSERTATIONS

1. Sijl, J. (2009, December, 16). "Ultrasound contrast agents - optical and acoustical characterization", University of Twente, (Enschede, The Netherlands: Physics of Fluids group). Promotoren: Prof. dr. D. Lohse and Prof. dr. ir. N. de Jong.

## SCIENTIFIC PUBLICATIONS

1. Marcia Emmer, Hendrik J. Vos, Michel Versluis, and Nico de Jong. Radial Modulation of Single Microbubbles. *IEEE T. Ultrason. Ferr.* 56, 2370 (2009).
2. Nico de Jong, Marcia Emmer, Annemieke van Wamel and Michel Versluis. Ultrasonic characterization of ultrasound contrast agents. *Med. Biol. Eng. Comput.* 47, 861-873 (2009).
3. A. Novell, S.M. van der Meer, M. Versluis, N. de Jong, A. Bouakaz. Contrast agent response to chirp reversal: Simulations, optical observations and acoustical verification. *IEEE T. Ultrason. Ferr.* 56, 1199 (2009).
4. Marcia Emmer, Hendrik J. Vos, David E. Goertz, Annemieke van Wamel, Michel Versluis, and Nico de Jong. Pressure-dependent attenuation and scattering of phospholipid-coated microbubbles at low acoustic pressures *Ultrasound Med. Biol.* 35, 102 (2009).

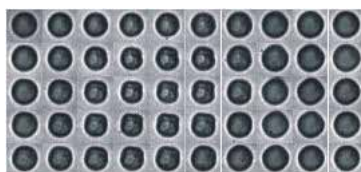

An example of "compression-only" behavior of a phospholipid coated microbubble, recorded with the Brandaris ultrahigh-speed camera. The optical images, show buckling of the phospholipid shell resulting from a high concentration of phospholipids on the bubble shell.

**PROJECT AIM**

The goal of the project is to characterize and quantify bubble accumulation (clustering) within the turbulent structures of the flow, and to study how bubbles affect the prevailing turbulence. Employment of novel experimental techniques is necessary, such as 3D Particle Tracking Velocimetry (PTV) and Phase Sensitive Constant Temperature Anemometry (CTA). The experimental results will provide useful information for the closures of front tracking simulations and point-like particle simulations as well.

**PROGRESS**

First experiments to study Lagrangian statistics of microbubbles in isotropic turbulence with  $Re_\tau > 200$  have been performed. Experiments are performed at the Twente Water Tunnel using a 3D-Particle Tracking system to obtain the microbubbles' positions in a measurement volume of  $5 \times 5 \times 5 \text{ cm}^3$ . Microbubbles with size compared to Kolmogorov's lengthscale of the flow ( $\approx 100 \text{ }\mu\text{m}$ ) are generated using a porous ceramic plate. Using the positions we can construct the particles' trajectories and get velocities and accelerations along them. PDFs of velocity and acceleration can thus be calculated (see figure below). At the moment we want to obtain longer trajectories aiming at better long-time Lagrangian statistics. For this we need to implement an algorithm to connect interrupted segments of the trajectories.

**DISSERTATIONS**

-

**SCIENTIFIC PUBLICATIONS**

-

**PROJECT LEADERS**

D Lohse

**RESEARCH THEME**

Complex dynamics of fluids

**PARTICIPANTS**

J Martínez Mercado, V Prakash,  
Y Tagawa, C Sun

**COOPERATIONS**

AKZO-Nobel, Corus, DSM, Shell,  
Prof. J.A.M. Kuipers, UT, Dr. M. van  
St. Annaland, UT, Dr. N. Deen, UT  
Dr. E. Calzavari, Dr. K. Sugiyama

**FUNDED**

FOM-IPP Programme: Fundamentals  
in heterogeneous bubbly flow.

University	-
FOM	100%
STW	-
NWO Other	-
Industry	-
TNO	-
GTI	-
EU	-
Scholarships	-

**START OF THE PROJECT**

2007

**INFORMATION**

D Lohse

053 489 8076

d.lohse@utwente.nl

http://pof.tnw.utwente.nl

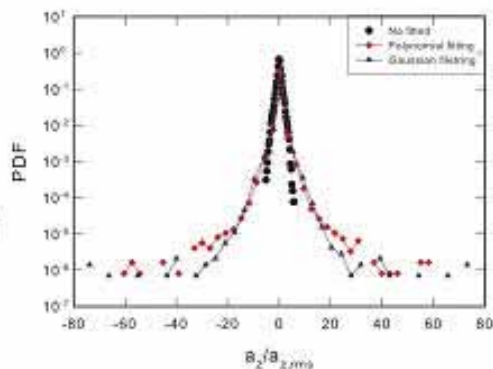
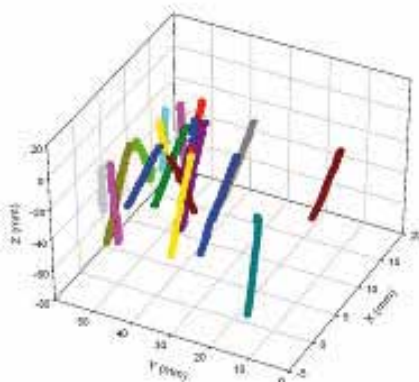



**PROJECT LEADERS**

JH Snoeijer

**RESEARCH THEME**

Complex dynamics of fluids

**PARTICIPANTS**

TS Chan, KG Winkels, D Lohse

**COOPERATIONS**

ASML BV, Veldhoven

**FUNDED**

FOM, ASML and, EU

University -

FOM 35%

STW -

NWO Other -

Industry 35%

TNO -

GTI -

EU 30%

Scholarships -

**START OF THE PROJECT**

2008

**INFORMATION**

JH Snoeijer

053 489 3085

j.h.snoeijer@tnw.utwente.nl

**PROJECT AIM**

The aim of this project is to study the instabilities of advancing and receding contact lines, both theoretically and experimentally. Most work in the literature has focused on contact line dynamics in the viscosity dominated regime, neglecting outer flow effects or inertia. However in situations close to instabilities the latter two assumption might be violated. This occurs, for example, in the context of immersion lithography, and therefore the project is in close collaboration with ASML. The main issues to be addressed in this project are: stability of contact lines over a broad range of velocities, bubble entrapment, high Reynolds number motion, constant acceleration and oscillations.

**PROGRESS**

For the theoretical approach, a numerical code based on a new two phase lubrication type model, is developed to study the critical speed for air entrainment near an advancing contact line. Results are verified with existing data from literature. With the used approach, new aspects of the air entrainment mechanism will be studied. For the experimental study, experiments are carried out on a turntable setup at ASML to investigate the effect of velocity on the dynamics of receding contact lines. Results are compared with theoretical models from literature that predict (i) a relation between the dynamic contact angle and the tip openings angle; and (ii) an exponential dependence of the tip curvature on the sliding velocity. Both predictions are in qualitative agreement with the experimental data. For further investigations, a similar turntable has been build at the University of Twente, which is capable of accurately rotating a glass wafer ( $\varnothing$  30 mm) with controlled velocity and acceleration.

**DISSERTATIONS**

-

**SCIENTIFIC PUBLICATIONS**

-

a) simplified sketch of the situation in immersion lithography systems, b) instabilities at the receding contact line.

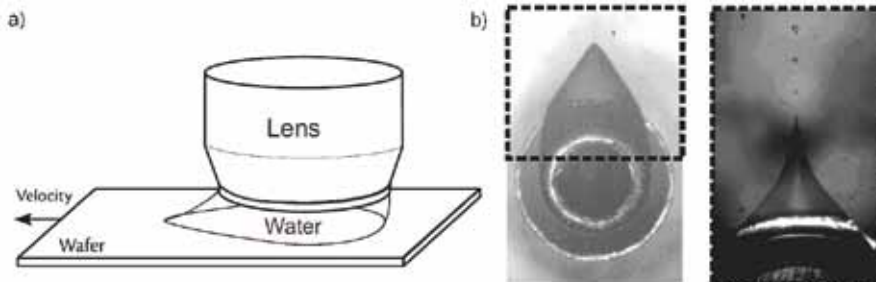

**PROJECT AIM**

A bubble that is entrained in the ink channel of a piezo-driven inkjet print head often leads to malfunction. This project works on an acoustic method to detect, prevent and understand the air entrapment. To complement the acoustic measurements, visual recordings of the droplet formation and air-entrapment are being done with high-speed cameras which verify the acoustic readings. In another part of the project the acoustics and the bubble-channel interaction inside the channel are modeled. In addition to the improvement of the stability of a print head, the dynamics of a bubble inside a confined space are studied in this project.

**PROGRESS**

The parameter space of bubble dynamics in an inkjet printhead has been investigated theoretically. A nonlinear model that describes the bubble dynamics in a confined space has been developed. With this model, theoretical predictions were confirmed. To find the relevant parameters for the droplet formation process, a second order accurate droplet formation model was developed, in which both droplet coalescence and separation can be simulated. Preliminary results from this model are shown in the figure below on the right hand side. Detailed experiments are conducted to verify the model and confirm the parameter study.

**DISSERTATIONS**

1. Roger Jeurissen. Bubbles in inkjet printheads: analytical and numerical models, October 23, 2009.

**SCIENTIFIC PUBLICATIONS**

1. R. Jeurissen, A. van der Bos, H. Reinten, M. van den Berg, H. Wijshoff, J. de Jong, M. Versluis, D. Lohse, Acoustic measurement of bubble size in an inkjet printhead, J. Acoust. Soc. Am. 126, (5) 2184-2190 (2009).

**PROJECTLEADERS**

D Lohse

**RESEARCHTHEME**

Complex dynamics of fluids

**PARTICIPANTS**

JA van der Bos, R Jeurissen, RJ Dijkink, TW Driessen, M Versluis

**COOPERATIONS**

H Reinten, H Wijshoff, M van den Berg, J de Jong (all Océ Technologies B.V.)

**FUNDED**

Océ Technologies, STW, MicroNed, HiPrins	
University	-
FOM	-
STW	35%
NWO Other	-
Industry	50%
TNO	-
GTI	-
EU	15%
Scholarships	-

**START OF THE PROJECT**

2005 - R Jeurissen  
 2006 - A van der Bos  
 2010 - T Driessen

**INFORMATION**

R Jeurissen  
 077 359 2717  
 r.j.m.jeurissen@tnw.utwente.nl

A van der Bos  
 053 489 4213  
 j.a.vanderbos@tnw.utwente.nl

T Driessen  
 06 24711850  
 T.W.Driessen@tnw.utwente.nl

D Lohse  
 053 489 8076  
 d.lohse@utwente.nl  
 http:// pof.tnw.utwente.nl

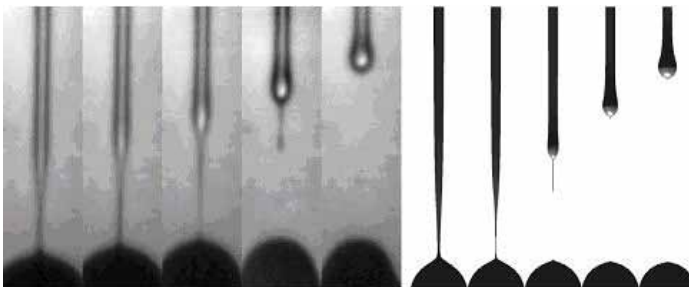

**PROJECT LEADERS**

D Lohse, M Versluis

**RESEARCH THEME**

Complex dynamics of fluids

**PARTICIPANTS**

W van Hoeve, M Versluis, D Lohse

**COOPERATIONS**MedSpray, Oce, Friesland-Campina,  
Prof. M. Brenner, Harvard**FUNDED**

MicroNed	
University	-
FOM	-
STW	-
NWO Other	-
Industry	100%
TNO	-
GTI	-
EU	-
Scholarships	-

**START OF THE PROJECT**

2007

**INFORMATION**

W van Hoeve  
053 489 4473  
w.vanhoeve@tnw.utwente.nl

**PROJECT AIM**

The aim of the project is to understand and control the formation of monodisperse droplets and bubbles. Bubbles and droplets with a well-controlled and narrow size distribution are important in several industrial and medical applications, e.g. in food industry the production of monodisperse powders through spray-drying results in a reduction of transportation and energy costs, in drug inhalation technology monodisperse droplets lead to an improved lung targeting, and in diagnostic ultrasound imaging monodisperse microbubbles can be used as ultrasound contrast agents.

**PROGRESS**

In this project we study the formation of microdroplets through the spontaneous breakup of a microscopically thin liquid jets into droplets. A liquid that is forced to flow through a nozzle at sufficient large velocity forms a jet that is inherently unstable. A small disturbance introduced by mechanical vibrations or thermal fluctuations will grow when its wavelength exceeds the jet's circumference. The wave that grows fastest is the optimum wavelength for jet breakup and governs the droplet size. This phenomenon is known as "Rayleigh breakup". We study the formation of these microdroplets using ultra high-speed microscopic imaging and within a lubrication approximation model.

**DISSERTATIONS**

-

**SCIENTIFIC PUBLICATIONS**

-

Time series of the spontaneous breakup of a liquid jet into a continuous stream of microdroplets.

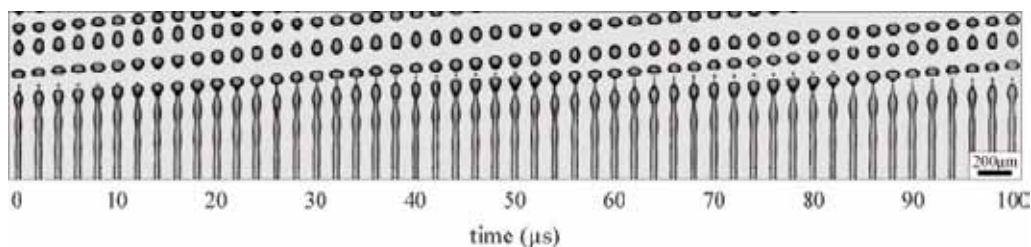





Prof.dr. F Mugele

### MISSION

The goal of the PCF group is to understand and control the structure and the mechanical properties of liquids and interfaces on length scales ranging from molecular to submillimeter scales. The activities fall in three main categories: i) nanofluidics, ii) (electro)wetting & microfluidics, iii) soft matter mechanics. Our nanofluidics research focuses on understanding the range of validity of macroscopic continuum physics and in its breakdown upon approaching molecular scales, where physico-chemical aspects become increasingly important. In microfluidics, many properties of fluids, in particular drops, are controlled by interfacial effects. By patterning surfaces and in particular by making use the electrowetting effect we control the shape, the motion, and the generation of microdrops. These processes involve various challenging fundamental issues, such as contact angle hysteresis, the dynamics of contact lines, and hydrodynamic singularities. The soft matter mechanics activities focus on correlations between the internal structure of various types of complex fluids ranging from colloidal suspensions to living cells and their macroscopic viscous and elastic properties.

By improving the physical understanding of fundamental phenomena we contribute to the improvement of various technological processes involving fluid motion on small scales, including oil recovery, immersion lithography, and inkjet printing. This work is frequently carried out in collaboration with industrial partners including BP, Shell, ASML, Océ, Liquavista, sometimes within government sponsored consortia such as FOM-IPPs, sometimes in direct collaboration. A major project on enhanced oil recovery started in late 2009 and became fully operational in 2010. In this context, the group intensified its activities in the area of physical chemistry of liquid-liquid and solid-liquid interfaces. In late 2010, Prof. Mugele obtained a NWO-VICI grant to investigate the properties of superhydrophobic surfaces that are functionalized by electric fields. One major goal of the project is to explore various applications of such smart surfaces for microfluidics, ultrasound detection, and in particular optofluidics.

## AFM SPECTROSCOPY OF CONFINED LIQUIDS

### PROJECT AIM

The goal is to get a quantitative understanding of the mechanical properties of liquids on small scales. To reach this goal we want to perform high resolution force measurements using atomic force microscopy. With an ultralow noise AFM system the molecular and surface forces in liquids will be determined. In particular we want to use Brownian force spectroscopy because it allows for the direct reconstructing interaction energies in thermal equilibrium with unprecedented resolution.

### PROGRESS

We set up an ultra-low noise AFM system. We examine the amplitude and phase of the AFM cantilever driven at very small amplitude upon approaching the tip towards the surface in a liquid medium. From the measured behavior of amplitude and phase we extracted both conservative interaction forces as well as dissipative forces of the nano-confined liquid films of octamethyltetrasiloxane confined between the tip and a solid (HOPG) substrate. This model liquid is known to display liquid layering. At the moment MD simulations are performed to get a better understanding of the system. The dynamic behavior of the cantilever has been modeled both analytically as numerically and the results are compared to the measurements. We have built an environmental control (to control temperature and humidity) for the AFM in order to study the behavior of the nano-confined liquids close to the freezing temperature. We have found that the conservative forces in liquids that are commensurate with the surface change dramatically when the freezing temperature is approached. Moreover, we have studied the effect of humidity on the adhesion of an AFM cantilever on hydrophilic and hydrophobic surfaces.

### DISSERTATIONS

-

### SCIENTIFIC PUBLICATIONS

1. On the shape of surface nanobubbles. B.M. Borkent, S. de Beer, F. Mugele, D. Lohse, *Langmuir*, 26, 260 (2010).
2. Instability of confined water films between elastic surfaces. S. de Beer, D. 't Mannetje, S. Zantema, F. Mugele, *Langmuir*, 26, 3280 (2010).
3. Plakkende gekko's. Waarom kan een gekko op muren en plafonds lopen? S. de Beer, A. Klaassen, B. Stel, F. Mugele, *NTvN* 76, 236 (2010).
4. Do epitaxy and temperature affect oscillatory solvation forces? S. de Beer, P. Wennink, M. van der Weide-Grevelink, F. Mugele, *Langmuir* 26, 13245 (2010).
5. Dissipation and the oscillatory solvation forces in confined liquids studied with small-amplitude atomic force spectroscopy. S. de Beer, D. van den Ende, F. Mugele, *Nanotechnology* 21, 325703 (2010).

### PROJECT LEADERS

F Mugele

### RESEARCH THEME

Complex structures of fluids

### PARTICIPANTS

S de Beer, F Mugele

### COOPERATIONS

-

### FUNDED

FOM

University -

FOM 100%

STW -

NWO Other -

Industry -

TNO -

GTI -

EU -

Scholarships -

### START OF THE PROJECT

2007

### INFORMATION

S de Beer

053 489 3093

s.j.a.debeer@utwente.nl

utwente.nl/tnw/pcf

**PROJECT LEADERS**

F Mugele

**RESEARCH THEME**

Complex dynamics of fluids

**PARTICIPANTS**

H Gu, MHG Duits, F Mugele

**COOPERATIONS**

-

**FUNDED**

MicroNed	
University	-
FOM	-
STW	-
NWO Other	-
Industry	100%
TNO	-
GTI	-
EU	-
Scholarships	-

**START OF THE PROJECT**

2006

**INFORMATION**

H Gu  
053 489 4236  
h.gu@tnw.utwente.nl  
utwente.nl/tnw/pcf

**PROJECT AIM**

The aim of this project was to explore the combination of electrowetting (EW) technology and droplet-based two-phase flow (TPF) platform, which would bring the advantages of both worlds together: (i) high throughput (from pressure-driven channel-based TPF) and (ii) precise control over each individual droplet (from EW).

**PROGRESS**

I. We designed and developed a new microfluidic platform which can offer on-demand droplet formation (DOD) and on-demand merging (MOD). DOD was implemented using the principle of EW. Using two synchronized DOD injectors, MOD was achieved via electrocoalescence.

II. We designed and developed a microfluidic tensiometer that is capable of measuring interfacial tensions between two liquids, directly from a force balance. This functionality is obtained by using a tapered microchannel, which offers a range of possible interface curvatures..

**DISSERTATIONS**

-

**SCIENTIFIC PUBLICATIONS**

1. H Gu, MHG Duits, F Mugele, "A hybrid microfluidic chip with electrowetting functionality using ultraviolet (UV)-curable polymer", Lab on a Chip, 10, 1550 (2010).
2. H Gu, MHG. Duits, F Mugele, "Controlled drop generation for digital microfluidic systems by means of electrowetting", Proceeding of the 14th international conference on micro total analysis systems, 2010, 1808-1810.

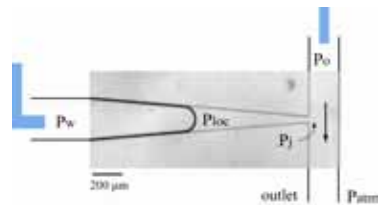
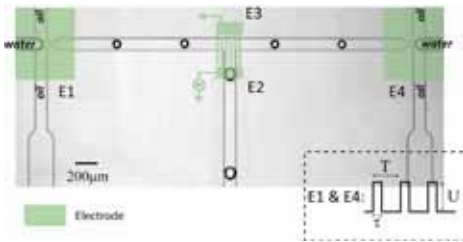

## IMBIBITION OF WATER INTO OIL-FILLED MICROCHANNELS WITH COMPLEX WALL PROPERTIES

### PROJECT AIM

At the level of individual pores, the efficiency of oil recovery is governed by the spontaneous and pressure driven imbibition of brine and the subsequent mobilization and flow of oil (and water) through the complex pore network. Chemical heterogeneity and topographic roughness control the initial distribution of oil and water in the pore space as well as the flow resistance experienced by mobilized oil. In this project, we will address these issues by generating microfluidic channels with specifically designed and controllable wall patterns to elucidate the fundamental physical processes underlying the mobilization of oil in porous media.

### PROGRESS

- We studied how solid layers are formed at the interface between aqueous salt solutions and decane with stearic acid, by monitoring the evolution of its mechanical, optical, and chemical properties. The cationic composition and pH of the aqueous phase have a strong influence on both the formation and the final properties of the interfacial layer.
- We validated time-resolved electrowetting as a method to determine dynamic interfacial tension for small fluid volumes.
- We studied the morphological transitions between the axisymmetric barrel and asymmetric clamshell states of drops on cylindrical fibers. We determined the stability limits of both morphologies and identified a regime in the morphology diagram where both states are mechanically stable. We find that the soft barrel state is easily deformed by non-axisymmetric perturbations.
- We started developing microfluidic devices to study how the interaction of a droplet with chemically or topographically patterned channel walls influences the flow field and hydrodynamic resistance in a microchannel.

### DISSERTATIONS

-

### SCIENTIFIC PUBLICATIONS

-

### PROJECT LEADERS

F Mugele

### RESEARCH THEME

Complex dynamics of fluids

### PARTICIPANTS

R de Ruiter, MHG Duits, F Mugele

### COOPERATIONS

Max Planck Institute for Dynamics and Self-Organization, University of Copenhagen, BP

### FUNDED

BP	
University	-
FOM	-
STW	-
NWO Other	-
Industry	100%
TNO	-
GTI	-
EU	-
Scholarships	-

### START OF THE PROJECT

2009

### INFORMATION

R de Ruiter  
053 489 3093  
r.deruiter-1@tnw.utwente.nl  
utwente.nl/tnw/pcf/



**PROJECTLEADERS**

F Mugele

**RESEARCHTHEME**

Complex dynamics of fluids

**PARTICIPANTS**

J de Ruiter, HTM van den Ende,

F Mugele

**COOPERATIONS**

Industrial partners: Océ, TNO, OTB

**FUNDED**

HIPRINS

University -

FOM -

STW -

NWO Other -

Industry 100%

TNO -

GTI -

EU -

Scholarships -

**START OF THE PROJECT**

2009

**INFORMATION**

J de Ruiter

053 489 3134

j.deruiter@tnw.utwente.nl

utwente.nl/tnw/pcf

**PROJECT AIM**

High-end printing of graphics and electronics requires a high degree of control of the spreading process of ink on the printing medium. The complex composition of both the surface and the ink makes the motion of the contact line and the spreading of the liquid a complex problem. The goal of the project is to understand the physical principles of spreading of model inks on model surfaces.

**PROGRESS**

We study the spreading dynamics of completely wetting droplets (pL-volume) on surfaces of variable roughness, set by the density of silica microspheres on a glass substrate. The local spreading rate  $n(R\sim t^n)$  shows a dependence on roughness, which varies with the subsequent spreading morphologies of the droplet. Starting from a spherical cap, a foot extends from the spreading and subsequently retracting reservoir, which finally results in a film-spreading regime. It is visually confirmed that the fluid does not merely imbibe the open spaces between the microspheres, but rather wets the complex surface structure in two steps: from the macroscopic wetting front a thin film extends that nucleates the formation of a meniscus at a nearby particle. The particle is subsequently engulfed by the front. We proceed to study the microscopic wetting details.

**DISSERTATIONS**

-

**SCIENTIFIC PUBLICATIONS**

-

## ELECTROWETTING CONTROLLED CONTACT LINE DYNAMICS

### PROJECT AIM

The goal of this project is to improve the understanding of both the physics of pinning and depinning of contact lines on structured surfaces and the dynamics of moving contact lines on such surfaces using electrowetting, with the ultimate goal of improving the performance of both immersion lithography and inkjet printing systems.

### PROGRESS

We studied the behaviour of small droplets sliding on surfaces with a high contact angle hysteresis (20-30°) under the influence of AC electrowetting. We found that the sliding velocity increases linearly with the applied voltage squared, while the minimum volume for a droplet to slide decreases linearly with the same. Using a force balance based on contact line friction, hysteresis, and a driving gravitational force these can both be modelled accurately. We began experiments on the rotary-table system. We especially focused on using interferometry to study the shape of droplets, although there are significant problems, notably the relatively large angle between the liquid and substrate, to overcome. Moreover, we now have a system to implement electrowetting on the large scales needed on the rotary-table system.

### DISSERTATIONS

-

### SCIENTIFIC PUBLICATIONS

-

### PROJECTLEADERS

F Mugele

### RESEARCHTHEME

Complex dynamics of fluids

### PARTICIPANTS

DJCM 't Mannetje, CU Murade, HTM van den Ende, F Mugele

### COOPERATIONS

FOM IPP

### FUNDED

FOM	
University	-
FOM	100%
STW	-
NWO Other	-
Industry	-
TNO	-
GTI	-
EU	-
Scholarships	-

### START OF THE PROJECT

2008

### INFORMATION

DJCM 't Mannetje

053 489 3089

[d.j.c.m.tmannetje@tnw.utwente.nl](mailto:d.j.c.m.tmannetje@tnw.utwente.nl)

[utwente.nl/tnw/pcf/](http://utwente.nl/tnw/pcf/)

**PROJECT LEADERS**

F Mugele

**RESEARCH THEME**

Complex structures of fluids

**PARTICIPANTS**

D Ebeling, F Mugele

**COOPERATIONS**

Max Planck Institute for Dynamics and Self-Organization, University of Copenhagen, BP

**FUNDED**

BP	
University	-
FOM	-
STW	-
NWO Other	-
Industry	100%
TNO	-
GTI	-
EU	-
Scholarships	-

**START OF THE PROJECT**

2009

**INFORMATION**

Daniel Ebeling  
053 489 3093  
Daniel.Ebeling@utwente.nl  
utwente.nl/tnw/pcf/

**PROJECT AIM**

- Analysis of tip-sample interaction forces in electrolyte solutions by means of atomic force microscopy
- Analysis of salt specific effects
- Analysis of concentration dependence

**PROGRESS**

Force interactions were measured by atomic force microscopy for aqueous solutions of different salts and different concentrations. Dynamic force spectroscopy was employed for this purpose which allowed the usage of sharp AFM tips and gives better lateral resolution than the standard techniques. The obtained results show a dependence on the concentration and the valency of the used electrolyte solution.

**DISSERTATIONS**

-

**SCIENTIFIC PUBLICATIONS**

-

**PROJECT AIM**

To study the effect of confinement on phase transitions of fluids. To investigate the stability of confined water layer in hydrophobic channel and phase-equilibrium. To develop theoretical understanding for the effect of hydrophobic surface on phase-equilibria.

**PROGRESS**

A chip consisting of nanochannels has been designed and fabricated. Our current focus is on instrumentation particularly on optimization of setup for studying effect of confinement on phase equilibrium. A preliminary study on hydrophobization of flat Si-SiO<sub>2</sub> terminated surface has been conducted and this process will be optimized for hydrophobization of channels.

**DISSERTATIONS**

-

**SCIENTIFIC PUBLICATIONS**

-

**PROJECTLEADERS**

MG Duits, F Mugele

**RESEARCHTHEME**

Complex structures of fluids

**PARTICIPANTS**

D Tiwari, MG Duits, F Mugele

**COOPERATIONS**

FOM IPP

**FUNDED**

NWO	
University	-
FOM	-
STW	-
NWO Other	100%
Industry	-
TNO	-
GTI	-
EU	-
Scholarships	-

**START OF THE PROJECT**

2010

**INFORMATION**

F Mugele  
 f.mugele@utwente.nl  
 utwente.nl/tnw/pcf/

## SUPPRESSING THE COFFEE STAIN EFFECT: HOW TO CONTROL COLLOIDAL SELF-ASSEMBLY IN EVAPORATING DROPS USING ELECTROWETTING

### PROJECT LEADERS

F Mugele

### RESEARCH THEME

Complex structures of fluids

### PARTICIPANTS

H Burak Eral, D Mampallil, F Mugele

### COOPERATIONS

-

### FUNDED

NWO

University -

FOM -

STW -

NWO Other 100%

Industry -

TNO -

GTI -

EU -

Scholarships -

### START OF THE PROJECT

2010

### INFORMATION

B Eral

53 489 2650

[h.b.eral@tnw.utwente.nl](mailto:h.b.eral@tnw.utwente.nl)

[utwente.nl/tnw/pcf/](http://utwente.nl/tnw/pcf/)

### PROJECT AIM

Evaporating drops of colloidal suspensions and solutions of non-volatile species leave behind ring-like solid residues along the contact line. This coffee stain effect – named after the most widely known representative of this class of structures – leads to an undesired inhomogeneous distribution of solutes, commonly encountered in coating and printing applications involving volatile solvents. Combinatorial analysis methods such as fluorescent microarrays and Mass spectroscopy are specific examples where the inhomogeneity of the residual deposits compromises the overall performance of a system. These combinatorial methods are frequently utilized to analyze essential biomolecules including DNA and proteins. We aim to control and suppress the Coffee stains using Electrowetting (EW). EW provides a noninvasive method to interfere and manipulate the underlying physics of colloidal self-assembly in evaporating drops.

### PROGRESS

We studied the influence of electrowetting on the formation of undesired solute residues, so-called coffee stains, during the evaporation of drop containing non-volatile solvents. Electrowetting is found to suppress coffee stains of both colloidal particles of various sizes as well as DNA solutions for alternating (AC) frequencies ranging from a few Hertz to a few tens of kHz. Two main effects are shown to contribute to the suppression: (i) the time-dependent electrostatic force prevents pinning of the three phase contact line. (ii) internal flow fields generated by AC electrowetting counteract the evaporation driven flux and thereby prevents the accumulation of solutes along the contact line.

### DISSERTATIONS

-

### SCIENTIFIC PUBLICATIONS

-

### PROJECT AIM

We want to understand how diffusion of colloidal particles in confined geometries can alter the diffusion. This underexplored area in physical chemistry touches several fundamental issues and has potential for applications of colloids in microfluidic chips. The question: How does diffusion evolves under confinement? will be addressed with techniques such as Confocal Microscopy, Particle tracking and microfluidic methods for confinement.

### PROGRESS

Video microscopy and particle tracking were used to measure the spatial dependence of the diffusion coefficient ( $D\alpha$ ) of colloidal particles in a closed cylindrical cavity. Both height and radius of the cylinder were equal to 9.0 particle diameters. The number of trapped particles was varied between 1 and 16, which produced similar results. In the center of the cavity,  $D\alpha$  turned out to be 0.75 times  $D_0$  measured in bulk liquid. On approaching the cylindrical wall, a transition region of about 3 particle diameters wide was found, in which the radial and azimuthal components of  $D\alpha$  decrease to respective values of 0.1 and 0.4 times  $D_0$ , indicating asymmetric diffusion. Hydrodynamic simulations of local drag coefficients for hard spheres produced very good agreement with experimental results. These findings indicate that the hydrodynamic particle-wall interactions are dominant, and that the complete 3D geometry of the confinement needs to be taken into account to accurately predict the spatial dependence of diffusion.

### DISSERTATIONS

-

### SCIENTIFIC PUBLICATIONS

1. Anisotropic and hindered diffusion of colloidal particles in a cylinder, H.B.Eral, M.Duits, J.M.Oh, D.van den Ende, F.Mugele Langmuir, 2010, 26 (22), pp 16722–16729.

### PROJECT LEADERS

F Mugele

### RESEARCH THEME

Complex dynamics of fluids

### PARTICIPANTS

HB Eral, MHG Duits, HTM van den Ende, F Mugele

### COOPERATIONS

-

### FUNDED

NWO-CW	
University	-
FOM	-
STW	-
NWO Other	100%
Industry	-
TNO	-
GTI	-
EU	-
Scholarships	-

### START OF THE PROJECT

2006

### INFORMATION

B Eral  
53 489 2650  
h.b.eral@tnw.utwente.nl,  
utwente.nl/tnw/pcf/

## RHEOLOGICAL STUDY OF JAMMING AND GLASS TRANSITION IN DENSE SUSPENSIONS OF SOFT PARTICLES

### PROJECT LEADERS

F Mugele, HTM van den Ende

### RESEARCH THEME

Complex structures of fluids

### PARTICIPANTS

HTM van den Ende, O Deshmukh

### COOPERATIONS

-

### FUNDED

FOM

University -

FOM 100%

STW -

NWO Other -

Industry -

TNO -

GTI -

EU -

Scholarships -

### START OF THE PROJECT

2009

### INFORMATION

HTM van den Ende

053 489 3105

[h.t.m.vandenende@utwente.nl](mailto:h.t.m.vandenende@utwente.nl)

[utwente.nl/tnw/pcf/](http://utwente.nl/tnw/pcf/)

### PROJECT AIM

1. To probe the structural rearrangements in jammed system at the onset of nonlinear behavior.

2. To study the evolution dynamical heterogeneities in glassy systems.

### PROGRESS

Using particle tracking microrheology, we studied the glass transition in dense suspensions of thermosensitive microgel particles. These suspensions can be tuned reversibly between the glass state at low temperature and the liquid state at high temperature. We measured the mean squared displacement (MSD) of the tracer particles as a function of temperature, which clearly showed the transition from a liquid like state to a glassy state. We also determine the local viscoelastic moduli ( $G'$  and  $G''$ ), from the MSDs using the Generalized Stokes-Einstein Relation. With particle tracking, one probes the viscoelastic moduli in a lower frequency range than with macrorheology, which makes it possible to determine the mean relaxation time that is inaccessible with macrorheology. We also studied the effect of the size of probe particles used for our measurements. It was observed that using very large probe particles induced localised effects that affected the measurements.

### DISSERTATIONS

-

### SCIENTIFIC PUBLICATIONS

-

## STABILITY OF CONFINED WATER LAYERS IN HYDROPHOBIC NANOCHANNELS

### PROJECT AIM

1. To study phase-transition in nanochannel.
2. To study stability of confined water layer in hydrophobic nanochannel.
3. To develop theoretical understanding for the effect of hydrophobic surface on phase-equilibria.

### PROGRESS

The result of capillarity filling in nanochannel is published in *Microfluidics and Nanofluidics*. New nanochannel is designed for measuring the phase shift in nano-confinement. The evaporation phenomena in nanochannel is observed and a simple model to predict the evaporation rate is developed. The result shows that the evaporation rate can be explained with the simple model in reasonable accuracy. The boiling point shifts in various thicknesses of nanochannels are also examined. For that purpose, the temperature control system is newly set-up with the accuracy of less than 0.1 degree.

### DISSERTATIONS

-

### SCIENTIFIC PUBLICATIONS

1. JM Oh, T Faez, S de Beer and F Mugele, Capillarity-driven dynamics of water-alcohol mixtures in nanofluidic channels, *Microfluid. Nanofluid.* 9, 123-129 (2010).

### PROJECTLEADERS

F Mugele

### RESEARCHTHEME

Complex structures of fluids

### PARTICIPANTS

F Mugele, HTM van den Ende, M van der Weide-Grevelink, JM Oh, D Tiwari

### COOPERATIONS

-

### FUNDED

NanoNed Network	
University	-
FOM	-
STW	-
NWO Other	-
Industry	100%
TNO	-
GTI	-
EU	-
Scholarships	-

### START OF THE PROJECT

2008

### INFORMATION

JM Oh  
053 489 3089  
j.m.oh@utwente.nl  
utwente.nl/tnw/pcf/



**PROJECT LEADERS**

F Mugele

**RESEARCH THEME**

Complex structures of fluids

**PARTICIPANTS**

D Mampallil Augustine, HTM van den Ende

**COOPERATIONS**

-

**FUNDED**

MicroNed network

University -

FOM -

STW -

NWO Other -

Industry 100%

TNO -

GTI -

EU -

Scholarships -

**START OF THE PROJECT**

2007

**INFORMATION**

HTM van den Ende

053 489 3105

H.T.M.vandenEnde@tnw.utwente.nl

utwente.nl/tnw/pcf/

**PROJECT AIM**

Development of a micro-rheometer driven by Electro-Osmotic Flow (EOF). By measuring the flow profile, for instance by optical techniques, one can determine the "stress"-shear rate" relation of complex fluids in a micro channel. With this rheometer the behavior of emulsions and non-Newtonian fluids containing protein aggregates flowing through micro channels will be studied. Study of the behavior of small clusters flowing through a micro channel will be studied, especially the interaction of the droplets/clusters with a DC and low frequency AC electric field. As an application the feasibility of particle separation in parallel flow will be investigated.

**PROGRESS**

A method to characterize EOF in microchannels is developed. With this method, the surface charge/zeta potential of the channel walls can be determined. Electro osmotic shear flow is produced inside the channel by chemically or electrically modifying the zeta potential of the channel wall. For the electric modification, suitable voltages were applied on the embedded gate electrodes on the channel walls. By varying the voltage, the shear rate can be controlled. Currently the characterization of the device was carried out using Newtonian liquids (eg: aqueous electrolytes).

**DISSERTATIONS**

-

**SCIENTIFIC PUBLICATIONS**

1. Dileep Mampallil, Dirk van den Ende, Frieder Mugele, Electrophoresis 2010, 31, 563–569.
2. Dileep Mampallil, Dirk van den Ende and Frieder Mugele, Proc. of the 14th International Conference on Micro Total Analysis Systems (MicroTAS), Groningen, Eds. S. Verpoorte, H. Andersson-Svahn, J. Emmeus, N. Pamme, 1124, 2010.

## FORMATION AND STABILITY OF (MONO)LAYERS UNDER VARYING PH AND SALT CONCENTRATION

### PROJECT AIM

- Implementation of ellipsometry for studies of thin films on optically isotropic and anisotropic substrates, and various interfaces: solid-gas, gas-liquid (BAM), liquid-liquid
- Analysis of salt concentration and pH effects on film formation and stability.

### PROGRESS

Ellipsometry was implemented for studies on thin films. Extension for, measurements on liquid-liquid interfaces was designed and a prototype was build. Pressure-area isotherms of fatty acid on sub-phase with varying salt concentration and pH were measured. Monolayers were transferred on solid substrates and examined with Ellipsometry (thickness and homogeneity).

### DISSERTATIONS

-

### SCIENTIFIC PUBLICATIONS

-

### PROJECTLEADERS

F Mugele

### RESEARCHTHEME

Complex structures of fluids

### PARTICIPANTS

A Brzozowska, F Mugele

### COOPERATIONS

BP

### FUNDED

BP

University -

FOM -

STW -

NWO Other -

Industry 100%

TNO -

GTI -

EU -

Scholarships -

### START OF THE PROJECT

2009

### INFORMATION

A Brzozowska

053 489 3096

A.M.Brzozowska@utwente.nl

utwente.nl/tnw/pcf/



Prof.dr.ir. EWC van Groesen

In our group AAMP we study natural phenomena or help to design and improve technical apparatus or processes. We investigate the propagation of surface waves on a layer of fluid, the shock propagation caused by volcano eruptions through the earth, and the way how light gets reflected and transmitted through different materials.

We study these aspects with a set of suitable mathematical techniques that we extend and improve constantly. Our understanding of the phenomena is reflected in the mathematical models, which are updated and improved with increased understanding from theoretical investigations and simulations. Except for their mathematical structure with intrinsic beauty, our investigations are often 'useful': for hydrodynamic laboratories we advise how to generate the wave fields that they want to produce in their tanks to test ships in realistic situations, the calculations of seismic events may lead to an understanding which earth quakes give rise to large tsunamis, the design of optical devices with nano-scale structures helps to advance telecommunication, etc.

The topics mentioned above are very diverse in their appearance, and cover length scales ranging from  $10^{-9}$  till  $10^7$  meter. The beauty of the mathematical descriptions is that they are actually quite similar: the major physical process is the evolution of waves, or an abstraction of it. Special properties that depend on the application are reflected in the mathematical structure of the wave equations that are at the basis of the models. For instance, energy or momentum conservation corresponds to symmetries in the mathematical formulations. Specific methods that we use include variational methods, which exploit the remarkable fact that often a certain optimality property can be found in the phenomenon. Except for theoretical methods, often supported with computer algebraic calculations, regularly we design larger or smaller simulation tools of a numerical nature.

For the design of these numerical schemes we aim to keep the special properties of our theoretical models as well, leading to consistent finite dimensional version of the infinite dimensional models.

The research in water waves contains various topics. Characteristic is that for irrotational flows we approach the problems in a unified consistent modelling way. This is based on the fact that upon neglecting dissipation, the full free surface equations have a basic variational structure (Luke, 1967), with the free surface equations described by a Hamiltonian system (Zakharov 1968, Broer 1974). In our modelling of specific wave fields, we exploit this structure by finding approximations of the kinetic energy part of the Hamiltonian. This is used for approximate models described by pde's like the shallow water equations, Boussinesq-, KdV and NLS-type of equations.

For numerical simulations, this structure is exploited to find consistent discretizations by variational restriction: the functionals defined on infinite dimensional spaces are restricted to finite dimensional subspaces, which may be high dimensional but may also be much more restricted by including essential properties of the phenomenon in the description, depending on the specific cases.

Within the basic approach, we include various active or passive boundary conditions, depending on the application (to generate waves by wave flaps for hydrodynamic laboratories, or bottom motions for seismic applications), or to allow a reflection-free description for calculations on numerical artificial windows. Locally, the activities are grouped in the projects Math Modelling and consistent Numerical Simulations, Free flows and Extreme Waves, Coastal Waves, and Seismic generation of waves.

**PROJECT AIM**

Wave groups propagating in the coastal zone experience combined effects of wave non-linearity, bathymetry, wave-current interaction and wave breaking. Long wave generation is one effect which plays an important role in coastal morphodynamics and the motion of moored ships, just as the large spatial variability of high waves. The aim of this project is to come to improved modeling and understanding of waves in the coastal area, including aspects of tsunami waves.

**PROGRESS**

The Finite Element implementation of the Variational Boussinesq Model was extended and generalized to several optimized vertical profile functions for waves above varying bottom. The AB-model was extended to varying bottom and to include reflected waves. Both codes performed very well in simulating irregular waves over a slope when compared to MARIN measurements. Results presented at the MARIN bench mark meeting in November 2010 are submitted for publication. In the project on effective boundary conditions we extended the conditions to 2HD and performed simulations with a shallow water model in 2D.

**DISSERTATIONS**

1. G. Klopman, Variational Boussinesq modelling of surface gravity waves over bathymetry, ISBN 978-90-365-3037-8, 27 May 2010, University of Twente.

**SCIENTIFIC PUBLICATIONS**

1. G. Klopman, E. van Groesen, M. Dingemans, A variational approach to Boussinesq modelling of fully non-linear water waves, Journal Fluid Mechanics 657 (2010) 36-63.

**PROJECTLEADERS**

EWC van Groesen

**RESEARCHTHEME**

Mathematical and computational methods for fluid flow analysis

**PARTICIPANTS**

I Lakhturov, D Adytia, W Kristina, Andonowati

**COOPERATIONS**

LabMath-Indonesia, Bandung Indonesia, MARIN Wageningen

**FUNDED**

UT, STW, NWO-ALW	
University	25%
FOM	-
STW	20%
NWO Other	50%
Industry	-
TNO	-
GTI	5%
EU	-
Scholarships	-

**START OF THE PROJECT**  
2003

**INFORMATION**

E van Groesen  
053 489 3413  
groesen@math.utwente.nl

## GENERATION OF DETERMINISTIC EXTREME WAVES IN HYDRODYNAMIC LABORATORIES

### PROJECT LEADERS

EWC van Groesen

### RESEARCH THEME

Mathematical and computational methods for fluid flow analysis

### PARTICIPANTS

Lie She Liam, I. Lakhturov, A Latifah, Andonowati, Mashuri

### COOPERATIONS

LabMath-Indonesia, Bandung Indonesia, MARIN Wageningen

### FUNDED

UT, STW, MARIN	
University	20%
FOM	-
STW	75%
NWO Other	50%
Industry	-
TNO	-
GTI	5%
EU	-
Scholarships	-

### START OF THE PROJECT

2002

### INFORMATION

E van Groesen  
053 489 3413  
groesen@math.utwente.nl

### PROJECT AIM

The study of deformations of surface waves is focused on 'extreme waves'. The motivation comes from generating large amplitude waves in hydrodynamic laboratories. We investigate the maximal amplification factor that can be obtained from nonlinear effects in various wave groups (BF-instability, bi-harmonic deformations, soliton interactions), and properties of 'extremal waves' for increasingly more complicated model equations.

### PROGRESS

For the Variational Boussinesq Model with one or more vertical potential profiles determined by Airy's theory of potential flows, and restricted to waves above flat bottom, we extended the new kinetic energy optimization principle. The resulting numerical code showed good results compared to focussing wave group experiments at MARIN. The numerical implementation of the AB2-equation, an improvement of the KP-equation, has been tested against specifically designed and executed measurements at MARIN. Research started on characterization and prediction of freak waves using phase information. Third order analytic approximates with the AB-equation showed very good results compared to MARIN measurements of bi-chromatic waves.

### DISSERTATIONS

-

### SCIENTIFIC PUBLICATIONS

1. L. She Liam & E. van Groesen, Variational derivation of KP-type equations, *Physics Letters A*, 374(2010) 411-415.
2. N. Karjanto & E. van Groesen, Qualitative comparisons of experimental results on deterministic freak wave generation based on modulational instability, *Journal of Hydro-environment Research* 3(2010) 186-192.
3. E. van Groesen, Andonowati, L. She Liam & I. Lakhturov, Accurate modelling of uni-directional surface waves, *Journal of Computational and Applied Mathematics* 234 (2010) 1747-1756 .





Prof.dr.ir. JWW van der Vegt



Prof.dr. HJH Clercx



Prof.dr.ir. BJ Geurts



Prof.dr.ir. JGM Kuerten

The research in the Numerical Analysis and Computational Mechanics (NACM) group in the Department of Applied Mathematics of the University of Twente concentrates on two main topics:

- ♦ The development, analysis and application of numerical algorithms for the (adaptive) solution of partial differential equations for problems originating from the physical and technical sciences, in particular (discontinuous Galerkin) finite element methods.
- ♦ Mathematical modeling of complex physical problems to make them accessible for computation, in particular for turbulence and geophysical problems. In order to support these activities a significant research effort is directed towards the development of hpGEM, an object oriented toolkit for finite element methods, written in C++, and suitable for high performance parallel computers. Important applications are in the fields of gas dynamics, wet chemical etching of microstructures, fluid structure interaction, two phase flows both dispersed and with free surfaces, water waves, large eddy simulation of turbulent flows, geophysical flows and computational electromagnetics. Many of these projects are conducted in close collaboration with groups in physics and chemical technology, large technological research institutes (NLR, MARIN, WL Delft Hydraulics, KNMI), and industry (DSM, AKZO and Shell).

The research is conducted in the research institute IMPACT and the research in two-phase flows is part of the UT spearhead program "Dispersed multiphase flows". The NACM group participates in the 3TU Center of Excellence for Multiscale Phenomena.

# COMPLEX WAVE-CURRENT INTERACTIONS IN A NUMERICAL WAVE TANK

## PROJECT AIM

Our aim is to develop a stable and accurate finite element method to model nonlinear free surface waves based on variational principles. In this method, we seek a finite element discretization that stems from a discrete variational formulation rather than a weak formulation. The advantage is that the resulting numerical discretization will preserve energy conservation, phase-space structure and variational structure. Further, the numerical scheme will show no decay in amplitude and will be suitable for long time simulations. A 2D potential flow solver is already developed and its extension to accommodate a wave maker and subsequently to a 3D potential flow solver are in development. Comparison will be made with laboratory data of 3D inertial waves by The Royal Netherlands Institute of Sea Research (NIOZ) and with wave tank data of the Maritime Research Institute Netherlands (MARIN).

## PROGRESS

A variational finite element method has been developed for nonlinear free surface waves based on Mile's variational principle. Numerical discretization constitute a variational finite element discretization in space and a symplectic discretization in time. Resulting numerical scheme conserves discrete energy and shows no decay in amplitude (see figure a & b). However, a dispersion error is observed for long time simulations for nonlinear waves propagating with uniform speed. The dispersion error can be significantly minimized by a correct combination of high order space and time discretization, but the key feature, i.e., stability of numerical scheme is achieved. We are now extending the variational finite element method to accommodate the wave maker and subsequently, validating with experimental data.

## DISSERTATIONS

-

## SCIENTIFIC PUBLICATIONS

1. Colin Cotter and Onno Bokhove, 2010: Water wave model with accurate dispersion and vertical vorticity. *Peregrine Commemorative Issue J. Eng. Maths.* 67, 33-54.
2. Ramkrishna Pasumarthy, Vijaya R. Ambati. Arjan J. van der Schaft, Port-Hamiltonian discretization for open channel flows, Memorandum 1927, Dept. of Applied Mathematics, University of Twente, Enschede. ISSN 1874-4850. <http://eprints.eemcs.utwente.nl/18651/>

Numerical solution of nonlinear Fenton waves propagating with uniform speed at initial (a) and final time (b); where, T is the time period. Observe that there is no decay in the amplitude of the wave profile. However, a dispersion error is seen through a phase shift between initial and final wave profile.

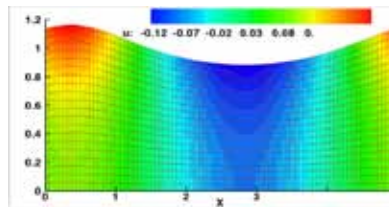
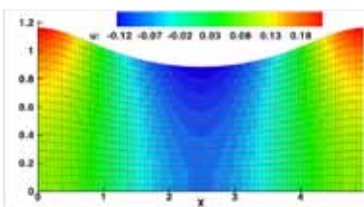

## PROJECT LEADERS

O Bokhove, JJW van der Vegt

## RESEARCH THEME

Mathematical and computational methods for fluid flow analysis

## PARTICIPANTS

S Nurijanyan, E Gagarina, VR Ambati

## COOPERATIONS

MARIN, NIOZ, Delft Hydraulics, Alkyon Hydraulic Consultancy & Research, and TU Delft Marine Technology

## FUNDED

STW	
University	-
FOM	-
STW	100%
NWO Other	-
Industry	-
TNO	-
GTI	-
EU	-
Scholarships	-

## START OF THE PROJECT

2008

## INFORMATION

VR Ambati  
053 489 3397  
[v.r.ambati@math.utwente.nl](mailto:v.r.ambati@math.utwente.nl)  
[www.math.utwente.nl/~ambativr](http://www.math.utwente.nl/~ambativr)

[o.bokhove@math.utwente.nl](mailto:o.bokhove@math.utwente.nl)  
[www.math.utwente.nl/~bokhoveo/](http://www.math.utwente.nl/~bokhoveo/)

[S.Nurijanyan@math.utwente.nl](mailto:S.Nurijanyan@math.utwente.nl)  
[www.math.utwente.nl/~nurijanyans](http://www.math.utwente.nl/~nurijanyans)

[e.gagarina@math.utwente.nl](mailto:e.gagarina@math.utwente.nl)  
[www.math.utwente.nl/~ambativr](http://www.math.utwente.nl/~ambativr)



**PROJECT LEADERS**

BJ Geurts

**RESEARCH THEME**

Mathematical and computational methods for fluid flow analysis

**PARTICIPANTS**

-

**COOPERATIONS**

Prof. H.J.H. Clercx (TUE/UT)

Prof. D.D. Holm (Imperial College)

Prof. E. Titi (UC Davis-Weizmann)

**FUNDED**

UT

University 100%

FOM -

STW -

NWO Other -

Industry -

TNO -

GTI -

EU -

Scholarships -

**START OF THE PROJECT**

-

**INFORMATION**

BJ Geurts

053 489 4125

b.j.geurts@utwente.nl

**PROJECT AIM**

The goal of this project is the development of multiscale models for the simulation of complex flows under turbulent conditions and through porous domains. Consequences of rotation, buoyancy combustion and interacting particles on flow-structuring are studied.

**PROGRESS**

Work was continued on the modulation of turbulence and a basic immersed boundary method was developed for flow in complex domains. A comprehensive error-analysis was executed.

**DISSERTATIONS**

-

**SCIENTIFIC PUBLICATIONS**

1. Geurts, B.J., Pratte, Stolz, S., P., Roux, V, Nordlund, M., Stabbert, R., Winkelmann, Ch.: 2010. Penetration of sub-micron aerosol droplets in composite cylindrical filtration elements, *Int. J. Heat Fluid Flow* doi:10.1016/j.ijheatfluidflow.2010.11.002.
2. Meyers, J., Meneveau, C., Geurts, B.J.: 2010. Error-landscape-based multi-objective calibration of the Smagorinsky eddy-viscosity using high-Reynolds-number decaying turbulence data, *Phys. Fluids* 22, 125106, doi:10.1063/1.3526758.
3. Kunnen, R.P.J., Clercx, H.J.H., Geurts, B.J.: 2010. Vortex statistics in turbulent rotating convection, *Phys. Rev. E* 82, doi: 10.1103/PhysRevE.82.036306.
4. Mourik, S. van, Geurts, B.J., Zwart, H., Keesman, K.: 2010. Modelling and controller design for a UV disinfection plant. *European Journal of Control* 16(2), 119-128.
5. Bos, F. van der, Geurts, B.J.: 2010. Computational error-analysis of discontinuous Galerkin discretization applied to large-eddy simulation of homogeneous turbulence, *Comput. Methods in Appl. Mech. Eng.* 199, 903-915, doi:10.1016/j.cma.2009.08.026.
6. Kunnen, R.P.J., Geurts, B.J., Clercx, H.J.H.: 2010. Experimental and numerical investigation of turbulent convection in a rotating cylinder, *J. Fluid Mech.* 642, 445 - 476.

**PROJECT AIM**

The target of the project is to understand aerosol particle dynamics in porous media. This will be done by performing numerical simulations and analysis of aerosol property evolution in complex geometries due to evaporation, condensation and collision.

**PROGRESS**

An existing Lagrangian particle tracking method was modified to assure physical consistency of the dynamics of massless particles near a solid/fluid interface within a porous media. This, in particular, provides a more accurate estimate of the impaction filtration efficiency of porous filters. The new algorithm is tested and verified for a structured porous medium. Currently, a model for filtration due to impaction as well as diffusion is being developed.

**DISSERTATIONS**

-

**SCIENTIFIC PUBLICATIONS**

1. Ghazaryan, L. and Lopez Penha, D.J. and Geurts, B.J. and Stolz, S. and Winkelmann, C. (2010) Simulation of impaction filtration by a porous filter. In: Proceedings of the 3rd International Conference on Porous Media and its Applications in Science, Engineering, and Industry, 20-25 June 2010, Montecatini, Italy. pp. 129-134. AIP Conference Proceedings 1254 (1). American Institute of Physics. ISSN 0094-243X.
2. Ghazaryan, L. and Lopez Penha, D.J. and Geurts, B.J. and Stolz, S. and Winkelmann, C. (2010). Simulation of impaction filtration of aerosol droplets in porous media. In: Proceedings of the V European Conference on Computational Fluid Dynamics ECCOMAS CFD 2010, 14-17 June 2010, Lisbon, Portugal.

**PROJECT LEADERS**

BJ Geurts

**RESEARCH THEME**

Mathematical and computational methods for fluid flow analysis

**PARTICIPANTS**

L Ghazaryan

**COOPERATIONS**

Philip Morris International – Dr.

Steffen Stolz

**FUNDED**

Philip Morris International

University -

FOM -

STW -

NWO Other -

Industry 100%

TNO -

GTI -

EU -

Scholarships -

**START OF THE PROJECT**

2008

**INFORMATION**

L Ghazaryan

053 489 3414

[l.ghazaryan@utwente.nl](mailto:l.ghazaryan@utwente.nl)

**PROJECT LEADERS**

BJ Geurts

**RESEARCH THEME**

Mathematical and computational  
methods for fluid flow analysis

**PARTICIPANTS**

J Mikhal

**COOPERATIONS**

Prof. Dr. Ir. C. H. Slump, SAS  
Group, EEMCS Department,  
University of Twente

**FUNDED**

University of Twente  
University      100%  
FOM              -  
STW              -  
NWO Other      -  
Industry        -  
TNO              -  
GTI              -  
EU                -  
Scholarships   -

**START OF THE PROJECT**

2008

**INFORMATION**

J Mikhal  
053 489 3414  
j.mikhal@ewi.utwente.nl

**PROJECT AIM**

Perform computational modeling, analysis and classification of flow topologies that occur in aneurysms in the human brain. Evaluation of the probability of rupture, and long-time stability are important factors.

**PROGRESS**

Work was concentrated around different model geometries of cerebral aneurysms. An Immersed Boundary method was developed to improve the representation near solid/fluid boundaries. Both constant – and pulsatile flow were implemented and analysed. Variations in the amplitude of the pulsatile lead to a range of complex dynamic behaviour of the flow inside model aneurysms, that is currently being investigated. A paper is being written on the basic simulation method. A companion physical experiment was build and executed – the result was negative in the sense that the required low Reynolds number could not be achieved with sufficient confidence experimentally. The simulation software was parallelized on the basis of OpenMP.

**DISSERTATIONS**

-

**SCIENTIFIC PUBLICATIONS**

1. Julia Mikhal, David J. Lopez Penha, Steffen Stolz, Bernard J. Geurts  
'Application of an immersed boundary method to flow in cerebral aneurysms and porous media.' In Proceedings of ASME Fluids Engineering Summer Meeting 2010, Montreal, Quebec, Canada, 01-04 August 2010.
2. Julia Mikhal, David J. Lopez Penha, Cornelis H. Slump, Bernard J. Geurts  
'Immersed boundary method predictions of shear stresses for different flow topologies occurring in cerebral aneurysms.' In Proceedings of V European Conference on Computational Fluid Dynamics, ECCOMAS CFD 2010, Lisbon, Portugal, 14-17 June 2010.

# SPACE–TIME DISCONTINUOUS GALERKIN FINITE ELEMENT METHOD FOR TWO-FLUID FLOWS

## PROJECT AIM

The computation of multifluid flows requires a special treatment of the interface, both in order to preserve accuracy but also to ensure conservation. This project develops a new discontinuous Galerkin finite element discretization which combines a novel local refinement technique of space-time meshes with an accurate treatment of the interface using specially developed numerical fluxes and a level set technique.

## PROGRESS

A novel numerical method for two-fluid flow computations was developed, which combines the space–time discontinuous Galerkin finite element discretization with the level set method and cut-cell based interface tracking. The space–time discontinuous Galerkin (STDG) finite element method offers high accuracy, an inherent ability to handle discontinuities and a very local stencil, making it relatively easy to combine with local hp-refinement. The front tracking is incorporated via cut-cell mesh refinement to ensure a sharp interface between the fluids. To compute the interface dynamics the level set method (LSM) is used because of its ability to deal with merging and breakup. The interface conditions are incorporated in the numerical flux at the interface and the STDG discretization ensures that the scheme is conservative as long as the numerical fluxes are conservative. The numerical method was applied to one and two dimensional two-fluid test problems using the Euler equations.

## DISSERTATIONS

1. Sollie, W.E.H. (2010) Space-time discontinuous Galerkin finite element method for two-fluid flows. PhD thesis, Univ. of Twente. ISBN 978-90-365-3008-8.

## SCIENTIFIC PUBLICATIONS

-

## PROJECT LEADERS

JJW van der Vegt

## RESEARCH THEME

Mathematical and computational methods for fluid flow analysis

## PARTICIPANTS

WEH Sollie, JJW van der Vegt,  
O Bokhove

## COOPERATIONS

-

## FUNDED

University of Twente	
University	100%
FOM	-
STW	-
NWO Other	-
Industry	-
TNO	-
GTI	-
EU	-
Scholarships	-

## START OF THE PROJECT

2002

## INFORMATION

JJW van der Vegt  
053 489 5628

[j.j.w.vandervegt@math.utwente.nl](mailto:j.j.w.vandervegt@math.utwente.nl)

[www.home.math.utwente.nl/~vegtjjw](http://www.home.math.utwente.nl/~vegtjjw)

#### PROJECT LEADERS

JJW van der Vegt

#### RESEARCH THEME

Mathematical and computational methods for fluid flow analysis

#### PARTICIPANTS

S Rhebergen, JJW van der Vegt, O Bokhove, T Julianto

#### COOPERATIONS

Dr. H. van der Ven, NLR

#### FUNDED

EU ADIGMA project, STW

University	-
FOM	-
STW	25%
NWO Other	-
Industry	-
TNO	-
GTI	-
EU	75%
Scholarships	-

#### START OF THE PROJECT

2009

#### INFORMATION

JJW van der Vegt

053 489 5628

[j.j.w.vandervegt@math.utwente.nl](mailto:j.j.w.vandervegt@math.utwente.nl)

[wwwhome.math.utwente.nl/~vegtjjw](http://wwwhome.math.utwente.nl/~vegtjjw)

#### PROJECT AIM

Multigrid methods are an important technique to solve the algebraic equations resulting from a discontinuous Galerkin finite element discretization. For lower order accurate DG discretizations of advection dominated flows this results in an efficient numerical algorithm, but with increasing order of accuracy this performance rapidly decreases. This project aims at developing new multigrid algorithms using a theoretical analysis of the error transformation operator for higher order accurate DG discretizations. This is important for many fluid dynamics problems which frequently occur at high Reynolds numbers.

#### PROGRESS

New optimized multigrid smoothers using point-implicit and semi-implicit Runge-Kutta methods were developed using three-level Fourier analysis of the complete hp-multigrid algorithm for fourth order accurate DG discretizations of 2D advection dominated flows. These algorithms, in combination with semi-coarsening multigrid, result in a large improvement of multigrid efficiency for higher order accurate DG discretizations. The multigrid performance remains very good even on highly stretched meshes.

#### DISSERTATIONS

1. Rhebergen, S. (2010) Discontinuous Galerkin finite element methods for (non) conservative partial differential equations. PhD thesis, University of Twente. ISBN 978-90-365-2964-8.

#### SCIENTIFIC PUBLICATIONS

1. Rhebergen, S. and van der Vegt, J.J.W. and van der Ven, H. (2010) Multigrid optimization for space-time discontinuous Galerkin discretizations of advection dominated flows. In: ADIGMA - A European Initiative on the Development of Adaptive Higher-Order Variational Methods for Aerospace Applications. Notes on Numerical Fluid Mechanics and Multidisciplinary Design 113. Springer-Verlag, Berlin, pp. 257-269. ISBN 978-3-642-03706-1.

### PROJECT AIM

The main aim of the project is the computational study of the dynamics of aerosols in turbulent flows. Emphasis will be given on the detailed numerical simulation of the various physical phenomena associated with the aerosol. We focus on the evolving size distribution of droplets undergoing evaporation and condensation in homogeneous isotropic turbulent flow. We also investigate the effect of thermophoresis and turbophoresis on the droplets in turbulent channel flow.

### PROGRESS

In our work we have studied the mathematical modelling and the DNS of the motion of aerosol droplets undergoing phase change due to evaporation and condensation in homogeneous isotropic forced turbulence. We first developed a mathematical model which incorporates only the mass coupling between the continuum and the dispersed phase and we performed simulations with this model. We computed the evolving probability distribution function (PDF) of the droplets' radii as a result of the phase change. We extended the model by incorporating the coupling of the flow of energy between the continuum and the dispersed phase. We implemented the new model and designed a testing and validation plan for this new implementation.

### DISSERTATIONS

-

### SCIENTIFIC PUBLICATIONS

1. Deb, B.S. and Ghazaryan, L. and Geurts, B.J. and Clercx, H.J.H. and Kuerten, J.G.M. and van der Geld, C.W.M (2010). The effect of phase transitions on the droplet size distribution in homogeneous isotropic turbulence. In: Proceedings of the V European Conference on Computational Fluid Dynamics ECCOMAS CFD 2010, 14-17 June 2010, Lisbon, Portugal. 01416. Technical University of Lisbon. ISBN 978-989-96778-1-4.
2. Deb, B.S. and Ghazaryan, L. and Geurts, B.J. and Clercx, H.J.H. and Kuerten, J.G.M. and van der Geld, C.W.M (2010). Effect of evaporation and condensation on droplet size distribution in turbulence. In: ERCOFTAC WORKSHOP Direct and Large-Eddy Simulation 8 DLES8, 7-9 July 2010, Eindhoven, The Netherlands.

### PROJECT LEADERS

BJ Geurts

### RESEARCH THEME

Mathematical and computational methods for fluid flow analysis

### PARTICIPANTS

B Sundar Deb, JGM Kuerten

### COOPERATIONS

Dr. A.K. Kuczaj. NRG –ECN. NL,  
Dr. D. Lakehal, ASCOMP GmbH.  
Switzerland, Dr. F. Menter, ANSYS  
Germany. GmbH, Ir. J Kruijthof.  
DAF Trucks. NL, Dr. J.G.M Kuerten.  
TU-Eindhoven

### FUNDED

STW	-
University	-
FOM	-
STW	100%
NWO Other	-
Industry	-
TNO	-
GTI	-
EU	-
Scholarships	-

### START OF THE PROJECT

2008

### INFORMATION

B Sundar Deb  
053 489 3460  
b.s.deb@utwente.nl



Prof.dr.ir. HWM Hoeijmakers



Prof.dr.ir. A Hirschberg

Research within the group Engineering Fluid Dynamics deals with theoretical, numerical and experimental studies, aimed for applications in Mechanical Engineering. The research focusses on the following fields:

#### **FLUID MECHANICS OF ROTATING FLOW MACHINERY**

The flow in centrifugal pumps and around wind turbine blades is studied experimentally and numerically, with the objective of developing methods for predicting the performance of these machines. This relates to head, efficiency and cavitation characteristics for pumps and generated power for wind turbines. The methods are used as tools for improving the design of these rotating machines. Also methods for inverse design and optimisation are considered. A new rotating test-rig has been developed for experimental studies of the flow in impeller channels.

#### **AERO-ACOUSTICS**

For Computational Aeroacoustics Discontinuous Galerkin finite-element methods for unstructured grids are developed for computing sound propagation in fluids. The capabilities of these methods are analysed analytically. Within the field of Experimental Aeroacoustics the generation of sound by objects is studied. For this an aero-acoustic test facility has been developed that is based on a closed circuit wind tunnel. The (0.7x0.9 m<sup>2</sup>) free-jet test-section (maximum velocity 65 m/s) of the silent wind tunnel is enclosed by a 6x6x4m<sup>3</sup> anechoic chamber.

#### **MULTI-PHASE FLOWS AND FLOWS WITH PHASE TRANSITION**

Models and unstructured-grid computational methods are developed for high-speed, swirling or non-swirling, condensing flows of mixtures of gases and liquids in complex geometries. Topics of interest are slipping droplets in turbulent flow and the prediction of the evolution of droplet radius distribution. Models and unstructured-grid computational methods are developed for liquid flows with unsteady sheet cavitation. Finally, phase transition is a driving mechanism in the study of ice accretion on aircraft wings in flight. Separation of oil/water mixtures is considered within a centrifugal force field generated in swirling pipe flows.

#### **FLUID-STRUCTURE INTERACTION AND FLOW CONTROL**

Research on fluid-structure interaction focuses on the flow-induced vibrations of compressor valves and on the unsteady motion of bluff bodies, in particular of gas bubbles and solid spheres induced by vortex shedding. Flow control is developed for application to wind turbine blades and diffusers. Both numerical and experimental investigations are conducted.

#### **THIN-FILM FLOWS**

The flow in narrow domains between deforming surfaces under extreme conditions is studied theoretically as well as experimentally. An example is the lubricant film in roller bearings, i.e. Elasto-Hydrodynamic Lubrication. The theoretical research involves modelling, development of efficient numerical solution algorithms and the use of these tools to derive general design rules for practical use. The experimental research employs a ball-on-disk apparatus and involves validation of predictions as well as the study of grease lubrication phenomena.

**BIO-PHYSICAL FLOWS**

This research deals with the flow in lungs, in particular the flow-induced deformation of the elastic lung tubes and the deposition of aerosols in lungs. Research is aimed at developing new diagnostic and therapeutic tools.



**PROJECT LEADERS**

NP Kruyt, HWM Hoeijmakers

**RESEARCH THEME**

Mathematical and computational methods for fluid flow analysis

**PARTICIPANTS**

RW Westra, NP Kruyt, K van Andel, HWM Hoeijmakers

**COOPERATIONS**

Flowserve BV

**FUNDED**

Senter, UT  
University -  
FOM -  
STW 25%  
NWO Other -  
Industry -  
TNO -  
GTI -  
EU 75%  
Scholarships -

**START OF THE PROJECT**

1998

**INFORMATION**

NP Kruyt  
053 489 2528  
n.p.kruyt@utwente.nl

**PROJECT AIM**

The hydraulic performance of pumps is studied both numerically and experimentally. For the numerical flow simulation a potential-flow method has been developed for the flow inside centrifugal and mixed-flow pumps. The method includes loss models and a cavitation inception model. The method has been extended to include a transpiration-type of model for the effect of sheet cavitation. The experimental work is carried out in the new Rotating Flow facility.

**PROGRESS**

In 2010 further work has been carried out and publication of results has been realized. The Rotating Flow facility is being redesigned so that higher rotational speeds become possible.

**DISSERTATIONS**

-

**SCIENTIFIC PUBLICATIONS**

-

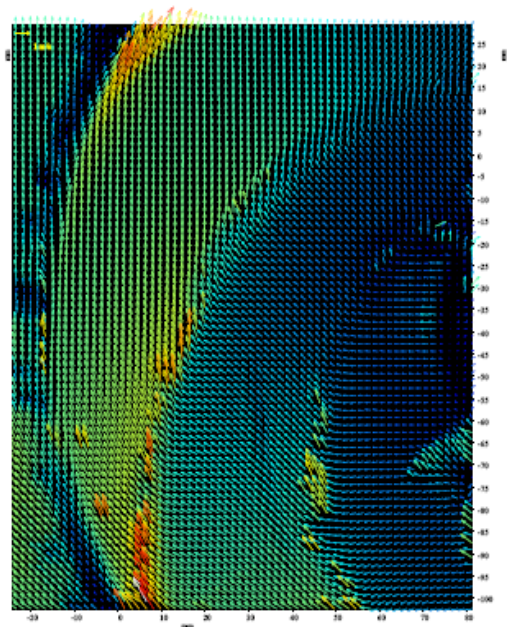
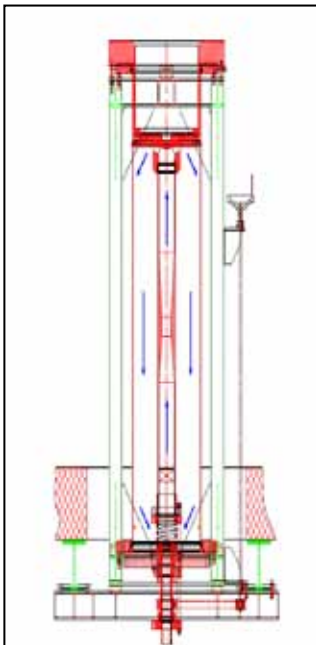

**PROJECT AIM**

Using the augmented potential-flow method developed for the prediction of the hydraulic performance of centrifugal and mixed flow pumps two types of design methods for three-dimensional configurations are investigated: (i) inverse-design methods and (ii) optimization methods. The validation of the computational methods has been carried out in the newly developed Rotating Flow facility, by PIV-measurements of the relative velocity field.

**PROGRESS**

A three-dimensional inverse-design method for impellers of centrifugal pumps has been developed, by which an impeller geometry is obtained that meets the prescribed hydraulic characteristics (rotational speed, flow rate, head and loading). Optimisation methods have been developed in which the performance of centrifugal pump impellers is optimised with respect to required head, low losses and optimal cavitation characteristics. The relative velocity field has been measured at various operating conditions using PIV, in the newly developed Rotating Flow facility. A publication has been effected.

**DISSERTATIONS**

-

**SCIENTIFIC PUBLICATIONS**

1. Westra, R.W. & Broersma, L. & Andel, K. van & Kruyt, N.P. (2010)  
PIV measurements and CFD computations of secondary flow in a centrifugal pump impeller. Journal of Fluids Engineering (Transactions of the ASME) 132 061104.

**PROJECT LEADERS**

NP Kruyt, HWM Hoeijmakers

**RESEARCH THEME**

Mathematical and computational methods for fluid flow analysis

**PARTICIPANTS**

RW Westra, NP Kruyt, K van Andel, HWM Hoeijmakers

**COOPERATIONS**

Flowserve BV, Urenco Aerospace, Johnson Pump, IHC Parts & Services, NLR, Marin

**FUNDED**

STW,UT	
University	-
FOM	-
STW	25%
NWO Other	-
Industry	-
TNO	-
GTI	-
EU	75%
Scholarships	-

**START OF THE PROJECT**

2003

**INFORMATION**

NP Kruyt  
053 489 2528  
n.p.kruyt@utwente.nl



**PROJECT LEADERS**

HWM Hoeijmakers, A Hirschberg

**RESEARCH THEME**

Mathematical and computational methods for fluid flow analysis

**PARTICIPANTS**

H de Vries, ETA van der Weide,  
A Hirschberg, HWM Hoeijmakers

**COOPERATIONS**

ECN

**FUNDED**

ECN, UT

University 30%

FOM -

STW -

NWO Other -

Industry -

TNO -

GTI 70%

EU -

Scholarships -

**START OF THE PROJECT**

2000

**INFORMATION**

HWM Hoeijmakers

053 489 4838

h.w.m.hoeijmakers@utwente.nl

**PROJECT AIM**

CFD methods for unsteady flows are developed for the aero-elastic behavior of flexible windturbine blades. The methods considered range from inviscid flow methods coupled to boundary-layer methods to time-accurate RANS methods. The flow conditions to be considered include cases with dynamic stall. Means for flow control are explored, both experimentally and computationally.

**PROGRESS**

In 2010 the research into the application of flow control devices, such as synthetic jets, on wind turbine rotor blades has continued, both experimentally and computationally. On the computational side of the research, the Unsteady Reynolds-averaged Navier-Stokes (URANS) method, which was developed in this project, has been combined with boundary conditions to simulate synthetic jet actuation. Subsequently, a parameter study of synthetic jet actuation for load control on a NACA 0018 airfoil has been started. Besides main-flow parameters and geometry parameters, this study includes actuation parameters such as the dimensionless actuation frequency and the dimensionless momentum addition by the jet. The URANS method is characterized by 2nd order accurate discretizations in space and time, an edge-based finite-volume formulation on unstructured, hybrid, two- or three-dimensional grids, parallelization using domain decomposition and an implicit solution method using algebraic agglomeration-based multigrid. On the experimental side of the research, the developed experimental set-up to test synthetic jet actuation on a NACA 0018 in Twente's silent wind tunnel has been adapted to include improved actuators.

**DISSERTATIONS****SCIENTIFIC PUBLICATIONS**

1. Konijn, B.J., Hoeijmakers, H.W.M., Jaarsma, F., Soemarwoto, B.I., Cock, K.M.J. de: 'One Dimensional Flow Theory for Diffuser Augmented Wind Turbines', (DVD). In S. Voutsinas & T. Chaviaropoulos (Eds.), Proceedings TORQUE 2010 The Science of making Torque from Wind, Heraklion, Crete, Greece, June 28 – 20, 2010. Paper 130, 9 pages.

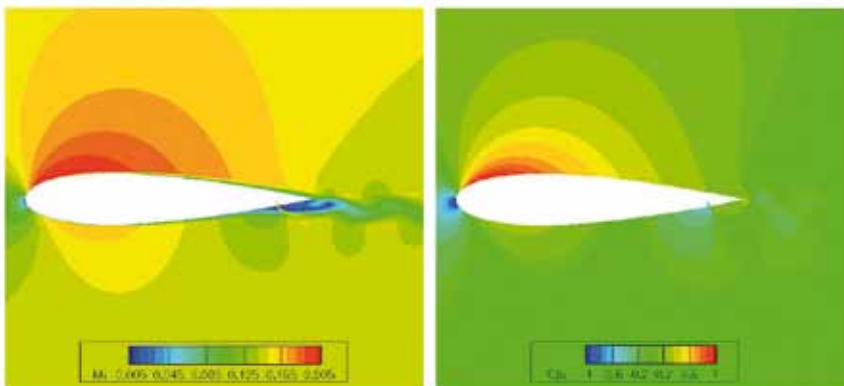

**PROJECT AIM**

Development of aerodynamic analysis tools and integration of these tools into a gradient based optimization framework such that the performance of wind turbine blades can be optimized according to a (user defined) objective function.

**PROGRESS**

In the optimization procedure the shape of the wind turbine blade will be modified during each design iteration. To accommodate the change in blade shape, the choice was made to employ multi-block overset grids for the discretization of the flow domain. A suitable method to establish the block connectivity was investigated and the choice was made to use a so-called implicit hole cutting method for this purpose. Furthermore, a ray-casting algorithm was implemented, which is used to identify cells that reside inside a geometrical entity that is in the flow domain. For the ray-casting procedure a non-overlapping surface grid is required, this is achieved by applying zipper grids in the regions where surface grids overlap each other.

**DISSERTATIONS**

-

**SCIENTIFIC PUBLICATIONS**

-

**PROJECT LEADERS**

HWM Hoeijmakers, ETA van der Weide

**RESEARCH THEME**

Mathematical and computational methods for fluid flow analysis

**PARTICIPANTS**

SH Jongsma, ETA van der Weide, HWM Hoeijmakers

**COOPERATIONS**

Suzlon Blade Technology

**FUNDED**

Suzlon Blade Technology	
University	-
FOM	-
STW	-
NWO Other	-
Industry	100%
TNO	-
GTI	-
EU	-
Scholarships	-

**START OF THE PROJECT**

2008

**INFORMATION**

ETA van der Weide  
053 489 2593  
e.t.a.vanderweide@utwente.nl

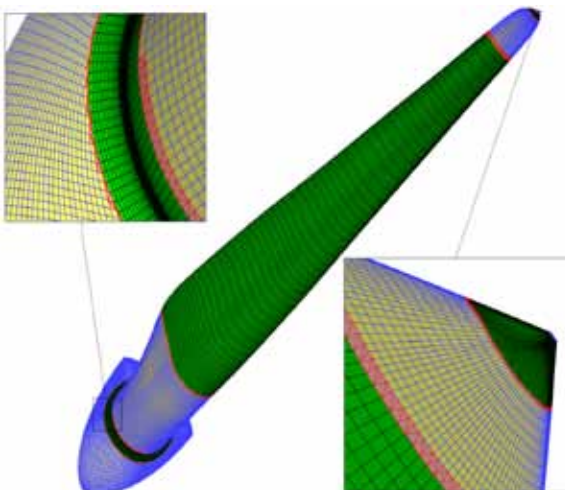

Surface grid on one blade and part of the nose cone, including zipper grid.

**PROJECT LEADERS**

HWM Hoeijmakers, ETA van der Weide

**RESEARCH THEME**

Mathematical and computational methods for fluid flow analysis

**PARTICIPANTS**

JM Tomas, H de Vries, ETA van der Weide, HWM Hoeijmakers

**COOPERATIONS**

-

**FUNDED**

EU (CleanSky Project)

University -

FOM -

STW -

NWO Other -

Industry -

TNO -

GTI -

EU 1005%

Scholarships -

**START OF THE PROJECT**

2009

**INFORMATION**

ETA van der Weide

053 489 2593

e.t.a.vanderweide@utwente.nl

**PROJECT AIM**

Investigate the possibility to apply synthetic jet flow control on the flaps of aircraft wings in order to increase the lift during take off and landing. The goal of this research is to determine the specifications of a synthetic jet flow control device in order to accomplish the desired effects.

**PROGRESS**

A spanwise row of jets through slots, which are equal in size and have equal distance from one another, has been applied to the trailing edge flap of the DLR-F15 airfoil in order to reduce the region of separated flow occurring when no actuation is applied. It is found that such a method of flow control can effectively reduce flow separation. The improvement in lift due to actuation is higher when shorter slots are applied compared to the optimized slots for an infinitely long wing using the NACA-0018 airfoil. However, to reach the same momentum coefficient the jet velocity must be increased. In this way the mass coefficient  $M_j$  can be reduced, i.e. less air is needed for actuation, while a higher jet velocity needs to be achieved.

**DISSERTATIONS**

-

**SCIENTIFIC PUBLICATIONS**

1. Jasper M. Tomas , Edwin T. van der Weide , Hein de Vries , Harry W.M. Hoeijmakers. Numerical Simulation of Flow Control by Synthetic Jet Actuation. 27th ICAS conference, Paper 371, Nice 2010.

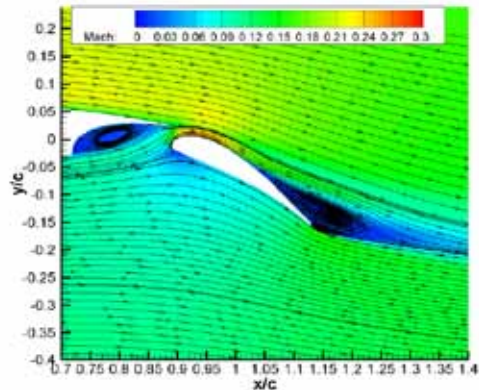

Without flow control

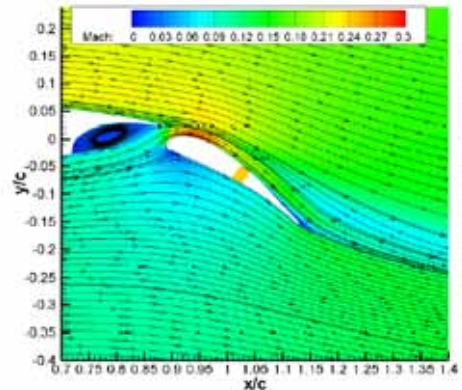

With flow control

**PROJECT AIM**

Computational Fluid Dynamics methods for unsteady flows are extended to numerically simulate flows including sound waves. Configurations aimed for are the flow over discontinuities, cavities, airfoils, blunt bodies, etc. Validation of computational results is pursued employing the Aero-Acoustic Test facility with a 0.9\*0.7 m2 (65 m/s) open-jet test section within an anechoic room of 6x6x4 m3.

**PROGRESS**

The linearized Euler equations in three spatial dimensions including source terms, as a physical-mathematical model for acoustic wave propagation in non-uniform background flow are considered. A Discontinuous-Galerkin (DG) Finite-Element method has been developed, employing tetrahedral or hexahedral elements and polynomial basis functions up to first degree for tetrahedral and up to third degree for hexahedral elements. SNGR methods for the prediction of broad band noise of obstructions in a duct are considered. PIV experiments have been carried out at the LEA for verification of theoretical predictions. The prediction of whistling tones by bluff bodies in free field conditions is considered based the analogy of Curle using as input LES incompressible flow simulations.

**DISSERTATIONS**

-

**SCIENTIFIC PUBLICATIONS**

-

**PROJECT LEADERS**

HWM Hoeijmakers, A Hirschberg

**RESEARCH THEME**

Complex dynamics of fluids

**PARTICIPANTS**

CH Venner, A Hirschberg HWM Hoeijmakers, ETA v.d. Weide, G Guilloud, C Schram, D Marx

**COOPERATIONS**

TNO, TU/e, VKI, LEA (Université Poitiers)

**FUNDED**

UT, EU (Aether project)	
University	25%
FOM	-
STW	-
NWO Other	-
Industry	-
TNO	-
GTI	-
EU	75%
Scholarships	-

**START OF THE PROJECT**

1999

**INFORMATION**

HWM Hoeijmakers  
053 489 4838  
h.w.m.hoeijmakers@utwente.nl

**PROJECT LEADERS**

A Hirschberg, HWM Hoeijmakers

**RESEARCH THEME**

Complex dynamics of fluids

**PARTICIPANTS**

A Mueller, E v.d. Wijden, J Dorneanu, A Hirschberg, P Rambaud

**COOPERATIONS**

VKI, TUDelft, LMS (Be)

**FUNDED**

UT, EU (Aether project, salary A.

Mueller)

University 25%

FOM -

STW -

NWO Other -

Industry -

TNO -

GTI -

EU 75%

Scholarships -

**START OF THE PROJECT**

1999

**INFORMATION**

A Hirschberg

053 489 4428

a.hirschberg@tue.nl

**PROJECT AIM**

Investigate experimentally the flow over discontinuities, cavities, airfoils, blunt bodies, etc. For this purpose the existing 0.9\*0.7 m2 (50 m/s) closed test section aerodynamic wind tunnel has been developed to an Aero-Acoustic Test facility (silent wind tunnel) with 0.9\*0.7 m2 (65 m/s) open jet test section within a 6x6x4m3 anechoic chamber.

**PROGRESS**

The whistling of a rod with square cross section placed with its axis normal to the flow has been measured as a function of the angle of incidence for Reynolds numbers up to 150 000. For angle of attack between 23 and 45 degree one observes two flow conditions, depending on the flow history. The first display strong whistling associated with periodic vortex shedding. The second is silent. Numerical simulations with incompressible LES and URANS have been carried out. The sound radiation predicted by means of Curle's analogy is compared to measurements.

**DISSERTATIONS**

-

**SCIENTIFIC PUBLICATIONS**

-

Zijaanzicht nieuw

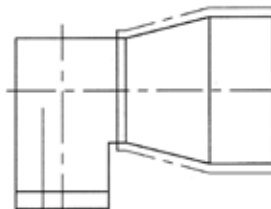

## EFFICIENT SOLUTION METHODS FOR N-COMPONENT CONDENSATION.

### PROJECT AIM

The objective of is to advance analysis of droplet size distributions in inviscid condensing flow. The background for this activity lies in the increasing demand from process industry for detailed and accurate data on condensing flows.

### PROGRESS

A computationally efficient method for the calculation of the binary cluster size distribution has been derived. The method is based on the phase path analysis algorithm, which was originally derived for single-component condensation. The method has been extended by constructing the binary general dynamic equation, which introduces clusters at a source point in two component composition space. The location of this source point is determined by the Gibbs free energy of formation and the impingement rates of the two constituents. The resulting model describes the binary cluster size distribution along a line in composition-space. The solution of the binary general dynamic equation is compared with the solution of formally exact binary Becker–Döring equations for a typical nucleation pulse experiment. The cluster composition and the integral properties of the size distribution agree very well. The computational work related to the phase path analysis algorithm is five orders of magnitude less than the computational work related to the Becker–Döring equations. In addition, a multigrid algorithm has been developed enabling faster solution of the cluster size distribution for N-component nucleation from the N-component Becker–Döring equations. The theoretical elaboration is valid for an arbitrary number of condensing components, making the simulation of many-component nucleating systems feasible. The method is applied to steady state ternary nucleation to demonstrate its efficiency. The results are used as a validation for existing ternary nucleation theories. The non-steady state ternary problem provides useful insight into the initial stages of the nucleation process.

### DISSERTATIONS

-

### SCIENTIFIC PUBLICATIONS

1. Putten DS van, Sidin RSR, Hagmeijer R. Efficient approximation of the cluster size distribution in binary condensation. (artikelnr 184511). J Chem. Phys. 2010,132,18.
2. Putten, D.S. van, Sidin, R.S.R., Hagmeijer, R.: Efficient algorithm for design and analysis of binary condensation experiments. Tampa, Florida, USA, International Conference on Multiphase Flow 2010, May 30 - June 4, 2010.

### PROJECTLEADERS

R Hagmeijer, HWM Hoeijmakers

### RESEARCHTHEME

Mathematical and computational methods for fluid flow analysis

### PARTICIPANTS

DS van Putten, R Hagmeijer, HWM Hoeijmakers

### COOPERATIONS

Twister BV

### FUNDED

Twister BV	
University	100%
FOM	-
STW	-
NWO Other	-
Industry	-
TNO	-
GTI	-
EU	-
Scholarships	-

### START OF THE PROJECT

2008

### INFORMATION

R Hagmeijer  
053 489 5605  
R.Hagmeijer@utwente.nl  
www.ts.ctw.utwente.nl/rob



**PROJECT LEADERS**

HWM Hoeijmakers, GH Schnerr

**RESEARCH THEME**

Mathematical and computational methods for fluid flow analysis

**PARTICIPANTS**

AH Koop, GH Schnerr,  
HWM Hoeijmakers

**COOPERATIONS**

UT, TUD, TU Munchen. Marin,  
Wartsila, Flowserve, IHC, Holland  
Roer Propellers, RNN

**FUNDED**

STW, UT	
University	10%
FOM	-
STW	90%
NWO Other	-
Industry	-
TNO	-
GTI	-
EU	-
Scholarships	-

**START OF THE PROJECT**

2003

**INFORMATION**

HWM Hoeijmakers  
053 489 4428  
h.w.m.hoeijmakers@utwente.nl

**PROJECT AIM**

Three-dimensional flows with steady and unsteady sheet cavitation are considered such as occur on hydrofoils. Computational methods are developed based on an unstructured-grid finite-volume method coupled to a dispersed-bubble model for cavitation as developed in prof. Schnerr's group in München. The project is a cooperation between the group at the UT and the group of prof. van Terwisga at Delft University of Technology where experiments are designed and carried out for obtaining data for validation of the computational results.

**PROGRESS**

An unstructured-grid Euler method for compressible flow has developed for flows with cavitation. The method assumed the liquid and the vapor to be compressible and the liquid-vapor mixture to be in mechanical and thermal equilibrium. Various upwind schemes have been implemented. Results show that the method gives promising results for the flow around 2D and 3D hydrofoils. The latter results are compared with experimental results obtained by Foeth & Terwisga in the Delft Cavitation Tunnel. In 2010 a new project has been defined (MIP-IOP) on vortex cavitation that has been granted. It will start in 2011.

**DISSERTATIONS**

-

**SCIENTIFIC PUBLICATIONS**

1. Huckriede, K.W., Koop, A.H., Hospers, J.M., Hoeijmakers, H.W.M.: 'Finite-Volume Method with Transpiration Boundary Conditions for Flow about Oscillating Wings', (DVD). In George K. Muellner & George Jacobs (Eds.), Conference Proceedings 48th AIAA Aerospace Sciences Meeting (DVD). Orlando, Florida, USA, January 4-7, 2010.
2. Koop, A.H., Hoeijmakers, H.W.M.: 'Unsteady Sheet Cavitation on Three-dimensional Hydrofoil', (DVD). In Curtiss & Balachandar (Eds.), Conference Proceedings 7th International Conference on Multiphase Flow, ICMF2010, Tampa, Florida, USA, May 30 – June 4, 2010. Paper 3.1.2, 12 pages.

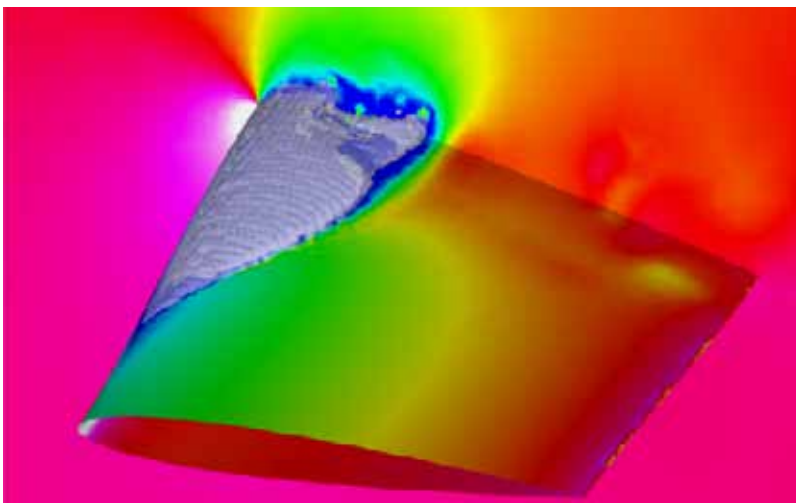

**PROJECT AIM**

Numerical simulation of ice accretion on aircraft wings in flight at (extreme) icing conditions, including effects of splashing of large super-cooled droplets on impact, droplet breakup in high-shear regions of the flow, droplet coalescence.

**PROGRESS**

Starting point has been a potential flow method coupled to a Lagrangian method to predict the water collection efficiency and to Messinger's model for the freezing thin layer of water along the surface. This method has been extended to poly-disperse droplet distributions and the capability to treat multi-element airfoil sections. Also a splashing-droplet model as well as a bouncing-droplet model has been adapted and implemented. Furthermore an Eulerian method for predicting the water collection efficiency has been developed, which is more suitable for complex configurations. Furthermore an unstructured-grid Euler method for compressible flow has adapted for coupling to the ice-accretion models.

**DISSERTATIONS**

-

**SCIENTIFIC PUBLICATIONS**

1. Hoppers, J.M., Hoeijmakers, H.W.M.: 'Eulerian Method for Ice Accretion on Multiple Element Airfoil Section', (DVD). In George K. Muellner & George Jacob (Eds), Conference Proceedings 48th AIAA Aerospace Sciences Meeting (DVD). ), Orlando, Florida, USA, January 4-7, 2010. Paper AIAA 2010-1236, 13 pages.
2. Hoppers, J.M., Hoeijmakers, H.W.M.: 'Eulerian Method for Ice Accretion on Multiple-Element Airfoils', (DVD). In Curtiss & Balachandar (Eds.), Conference Proceedings 7th International Conference on Multiphase Flow, ICMF2010, Tampa, Florida, USA, May 30 – June 4, 2010. Paper 171.1, 14 pages.
3. Hoppers, J.M., Hoeijmakers, H.W.M.: 'Numerical Simulation of SLD Ice Accretions' ICAS2010-2.4 ST2, CD-rom en online.. In Ian Grant (Ed.), Proceedings 27th Congress of the International Council of the Aeronautical Sciences (pp. 1-15). Nice: International Council of the Aeronautical Sciences.

**PROJECTLEADERS**

HWM Hoeijmakers

**RESEARCHTHEME**

Mathematical and computational methods for fluid flow analysis

**PARTICIPANTS**

JM Hoppers, HWM Hoeijmakers

**COOPERATIONS**

TU Darmstadt, CIRA, INTA, ONERA,

**FUNDED**

EU, UT	
University	20%
FOM	-
STW	-
NWO Other	-
Industry	-
TNO	-
GTI	-
EU	80%
Scholarships	-

**START OF THE PROJECT**

2008

**INFORMATION**

HWM Hoeijmakers  
 053 489 4428  
[h.w.m.hoeijmakers@utwente.nl](mailto:h.w.m.hoeijmakers@utwente.nl)

Calculated droplet distributions [kg/m3], region near the leading edge, 236 µm MVD, bin 1 (16 µm)

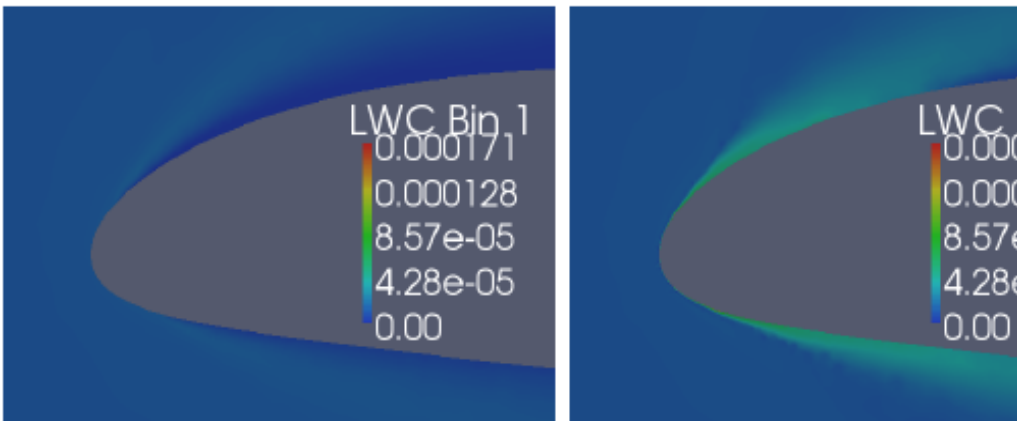

**PROJECT LEADERS**

HWM Hoeijmakers

**RESEARCH THEME**

Mathematical and computational methods for fluid flow analysis

**PARTICIPANTS**

JJ Slot, HWM Hoeijmakers

**COOPERATIONS**TUD, Tue, Shell, FMC Technologies  
- CDS Engineering BV, Frames,  
Wintershall, WUR**FUNDED**

ISPT, UT	
University	20%
FOM	-
STW	-
NWO Other	-
Industry	-
TNO	-
GTI	-
EU	80%
Scholarships	-

**START OF THE PROJECT**

2008

**INFORMATION**HWM Hoeijmakers  
053 489 4428  
h.w.m.hoeijmakers@utwente.nl**PROJECT AIM**

Modeling and numerical simulation of swirling flow of oil/water mixtures aimed at separation. An experimental set-up is developed at TU Delft for experimental investigation of these flows and providing data for validation. At Wageningen University the behavior of oil-water mixtures is studied at the micro-scale, including droplet coalescence and the effect of surfactants.

**PROGRESS**

Using CFD, the single-phase swirling water flow in the inline bulk oil-water separator has been considered in detail and agree well with experimental measurements. The results show a complex flow pattern with regions of reversed flow. Two-fluid models are currently employed to study the flow field and separation characteristics. Two-phase experiments are carried out and it will be used to validate the numerical models for these flows. Evolution of the droplet size distribution of the dispersed oil phase will be computed using populations balance models. These models are tailored to this specific application by using experimental research carried out at WUR.

**DISSERTATIONS**

-

**SCIENTIFIC PUBLICATIONS**

1. Slot, J. J. Campen, L. J. A. M., Hoeijmakers, H. W. M. en Mudde, R. F., Separation of Oil Droplets in Swirling Water Flow, International Conference on Multiphase Flow 2010, Tampa, Florida, USA.

Results droplet tracking in design of inline separator

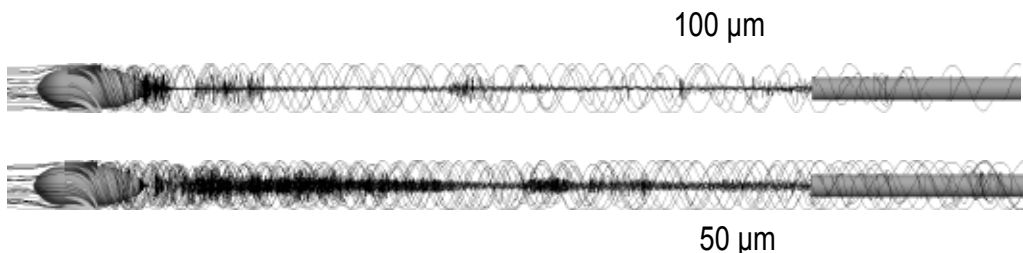

# MULTIPHASE FLOW EFFECTS IN COMPACT PRODUCED-WATER TREATMENT EQUIPMENT

## PROJECT AIM

The physical phenomena occurring during produced-water treatment are studied numerically. Oil droplet, and gas bubble trajectories will be predicted for both swirling flow and settling conditions. Influence of effects such as a history term are required for prediction of trajectories. Collision and coalescence are important factors for advanced compact produced-water treatment. Occurrence of such effects is predicted making use of droplet and bubble trajectories.

## PROGRESS

A Lagrangian particle tracking method has been developed for generic flow fields. Both implicit Crank-Nicolson, and explicit fourth order Runge-Kutta schemes have been implemented. History force has been identified as force that needs to be investigated. A new expression for the history kernel has been obtained using experimental data from literature to extend existing Reynolds dependent kernel. A Lattice Boltzmann Method code for gas, with extension to fluids via body force, has been developed to investigate influences on history force in detail. Both explicit and implicit schemes have been implemented. 2-D flow about a cylinder has been investigated to explore the method, and the method has been extended to 3-D flow about a sphere.

## DISSERTATIONS

-

## SCIENTIFIC PUBLICATIONS

1. Influence of the history term in a Lagrangian method for oil-water separation” – 7th International Conference on Multiphase Flow 2010, Florida, Tampa.

## PROJECT LEADERS

HWM Hoeijmakers

## RESEARCH THEME

Mathematical and computational methods for fluid flow analysis

## PARTICIPANTS

DF van Eijkeren, HWM Hoeijmakers

## COOPERATIONS

FMC Technologies/CDS Separation Systems.

## FUNDED

FMC Technologies/CDS Separation Systems

University	-
FOM	-
STW	-
NWO Other	-
Industry	100%
TNO	-
GTI	-
EU	-
Scholarships	-

## START OF THE PROJECT

2009

## INFORMATION

DF van Eijkeren

053 489 2482

d.f.vaneijkeren@utwente.nl

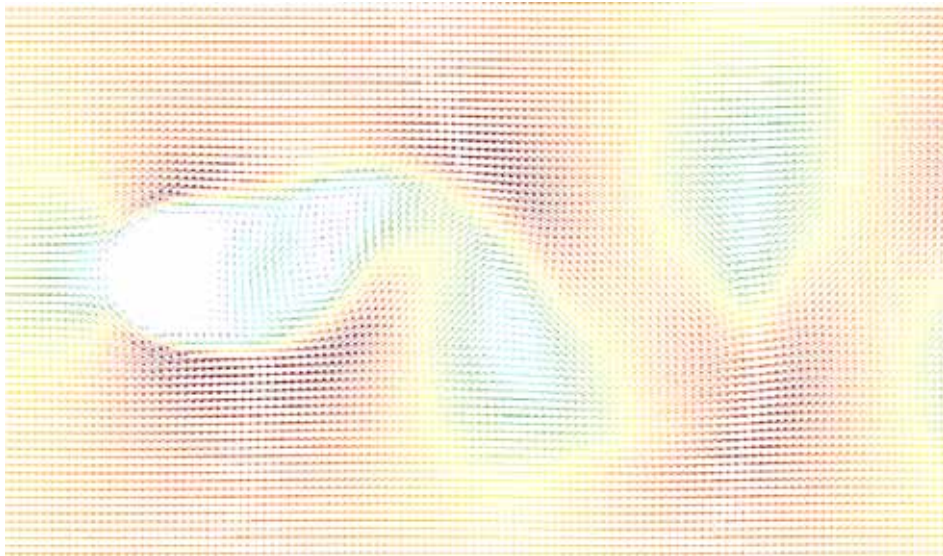

**PROJECT LEADERS**

HWM Hoeijmakers, CH Venner

**RESEARCH THEME**

Mathematical and computational methods for fluid flow analysis

**PARTICIPANTS**

CH Venner, HWM Hoeijmakers, M van Zoelen (SKF) PM Lugt (SKF), J Snoeijer (PoF, UT)

**COOPERATIONS**

INSA-de Lyon, France, SKF ERC, VOJA

**FUNDED**

University	50%
FOM	-
STW	-
NWO Other	-
Industry	50%
TNO	-
GTI	-
EU	80%
Scholarships	-

**START OF THE PROJECT**

2007

**INFORMATION**

CH Venner  
053 489 2488  
c.h.venner@utwente.nl

**PROJECT AIM**

Development of accurate thin film/layer flow models and numerical simulation algorithms for the prediction of lubricant film formation capacity and lubrication life in rolling element bearing contacts in relation to operating conditions, lubricant rheology (oil-grease), and supply conditions (starved-flooded).

**PROGRESS**

The general ‘inlet length’ mechanism governing the film formation and response to dynamic variations in EHL contacts has been re-investigated and shown to imply self similarity in the solution in a similar way as found in the so-called ‘Bretherton problem’ of droplet flow in a narrow tube. Using developed models and computational methods narrow elliptic contacts have been studied. The results have revealed that the ratio central to minimum film in such contacts is a function of the same single non-dimensional parameter reflecting ‘inlet control’. The results imply a major step forward to generalized film thickness formula valid for all point contacts. Free surface thin layer flow models have been used to optimize rolling element shape to minimize lubricant loss by pressure ejection to extend lubrication life of bearings. Film formation of grease in a model ElastoHydrodynamic lubrication has been studied in the contact between a steel ball and a coated glass disc using optical interferometry. Grease exhibits complex rheological behavior which provides challenging possibilities for film optimization in bearings by ‘smart grease composition’ and ‘active local redistribution’. The results have shown that grease lubricated contacts operate in a heavily starved regime and film thickness is mostly very insensitive to speed unless local resupply by low viscous material (base-oil) occurs.

**DISSERTATIONS**

**SCIENTIFIC PUBLICATIONS**

1. Zoelen, M.T. van, Venner, C.H., Lugt, P.M.: Free Surface Thin Layer Flow in Bearings Induced by Centrifugal Effects. Tribol. trans., (ISSN 1040-2004), 53(3), 297-307.
2. Zoelen, M.T. van, Venner, C.H., Lugt, P.M.: The Prediction of Contact Pressure-Induced Film Thickness Decay in Starved Lubricated Rolling Bearings. Tribol. trans., (ISSN 1040-2004), 53(6), 831-841.
3. Canzi, A., Lubrecht, A.A., Venner, C.H.: Film Thickness Predictions in Elastohydrodynamically Lubricated Elliptical Contacts. Proc. ImechE, Part J. J. of Engineering Tribology, (ISSN 1350-6501) 224(9), 917-923.
4. Venner, C.H., and Lubrecht, A.A.: Revisiting Film Thickness in Slender EHL Contacts, Proc. ImechE, part C., J. of Mechanical Engineering Science (ISSN 0954-4062), 224, 2549-2448.

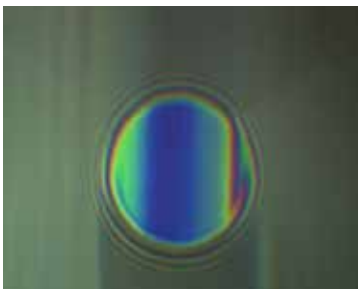

Interferometric image of the film thickness in a grease lubricated contact between a steel ball and glass disc (left). Central film thickness versus rolling speed for grease lubrication compared to base oil lubrication.

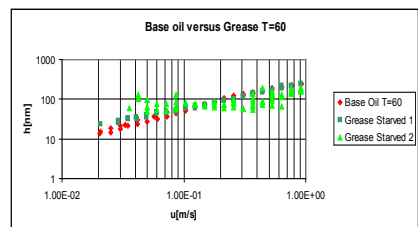

**PROJECT AIM**

Development of a mixed lubrication model based on physical first principles representing relevant aspects on different scales to predict the behaviour of concentrated contacts as appearing between rolling elements and raceways in rolling element bearings under extreme operating conditions of very limited lubricant supply.

**PROGRESS**

Development of a concept for mixed contact modeling and a multigrid algorithm for the efficient numerical solution. The model is based on a “bottom-up” approach, from dry contact to fully lubricated situation. The dry contact model uses linear elasticity theory. The pressure in dynamic pockets or dents filled with fluid (oil) is generated by fluid behaviour. As a first step a dry contact with a single dent in which a volumetric compression law is used has been used as a model problem. The next step is to assume more elastic flow equations in the pockets and to model multiple pockets or islands. To be able to identify pockets and contact regions from actually measured results image analysis methods will be used from the field of “vision”. In particular emphasis will be on multiscale image segmentation. Experiments will be carried out in a controlled single contact setting using optical interferometry and high speed camera equipment to generate data to validate and guide further model development.

**DISSERTATIONS**

-

**SCIENTIFIC PUBLICATIONS**

-

**PROJECT LEADERS**

CH Venner, HWM Hoeijmakers

**RESEARCH THEME**

Mathematical and computational methods for fluid flow analysis

**PARTICIPANTS**

E van Emden, CH Venner, HWM Hoeijmakers, GE Morales-Espejel (SKF)

**COOPERATIONS**

SKF

**FUNDED**

SKF	
University	-
FOM	-
STW	-
NWO Other	-
Industry	100%
TNO	-
GTI	-
EU	-
Scholarships	-

**START OF THE PROJECT**

2009

**INFORMATION**

CH Venner  
053 489 2488  
c.h.venner@utwente.nl

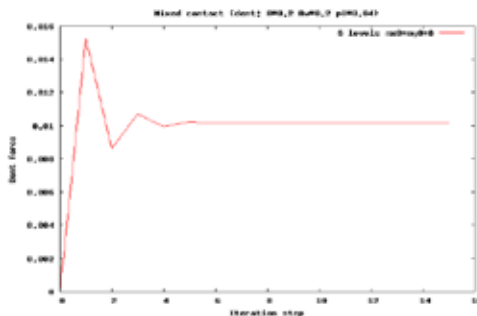
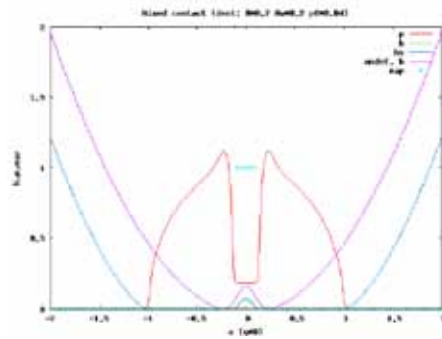
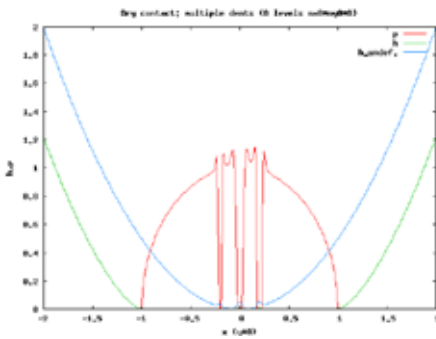

**PROJECT LEADERS**

NP Kruyt

**RESEARCH THEME**

Mathematical and computational methods for fluid flow analysis

**PARTICIPANTS**

NP Kruyt

**COOPERATIONS**

University of Waterloo, Canada,  
University of Leeds, Université  
Joseph Fourier, Grenoble, France

**FUNDED**

UT

University 100%

FOM -

STW -

NWO Other -

Industry -

TNO -

GTI -

EU -

Scholarships -

**START OF THE PROJECT**

2003

**INFORMATION**

NP Kruyt

053 489 2528

n.p.kruyt@utwente.nl

**PROJECT AIM**

The study of the (micro-mechanical) behavior of slowly flowing granular materials, in particular of the relation between microscopic behaviour and the macroscopic, continuum behaviour.

**PROGRESS**

The accuracy of three-dimensional, micromechanical expressions for the strain tensor have been investigated. The most accurate one, due to Bagi, has been used to study the deformation characteristics of granular materials from the micromechanical viewpoint. Elastic properties of granular materials in the isotropic state have been investigated theoretically. Links between macroscopic plasticity and microscopic behaviour have been studied.

**DISSERTATIONS**

-

**SCIENTIFIC PUBLICATIONS**

1. Kruyt, N.P. (2010). Three-dimensional lattice-based dispersion relations for granular materials IUTAM-ISIMM Symposium on Mathematical Modeling and Physical Instances of Granular Flows, AIP Conference Proceedings Vol.1227, pp.405–415, eds. J.D. Goddard & J.T. Jenkins & P. Giovine.
2. Kruyt, N.P. (2010). Micromechanical study of plasticity of granular materials Comptes Rendus Mécanique 338 596–603.
3. Kruyt, N.P. & Agnolin, I. & Luding, S. & Rothenburg, L. (2010). Micromechanical study of elastic moduli of loose granular materials. Journal of the Mechanics and Physics of Solids 58 1286–1301.
4. Durán, O. & Kruyt, N.P. & Luding, S. (2010). Micro-mechanical analysis of deformation characteristics of three-dimensional granular materials. International Journal of Solids and Structures 47 2234–2245.
5. Durán, O. & Kruyt, N.P. & Luding, S. (2010). Analysis of three-dimensional micro-mechanical strain formulations for granular materials: evaluation of accuracy. International Journal of Solids and Structures 47 251–260.

**PROJECT AIM**

Inhalation of therapeutic aerosols to treat lung diseases (e.g. asthma) is a problem since the upper airways (nose/mouth region) acts as a natural filter (especially for small subjects (e.g. children). Results of in vitro measurements and CFD calculations show considerable differences. More over the difficult geometry and non stationair breathing patterns complicate the calculations. The ultimate aim is to predict how and which aerosols should be inhaled to maximize deposition in the required regions and avoid uper airway deposition in the individual patient.

**PROGRESS**

In the last year a master student (T. Huijgen) worked on his master thesis on CFD calculations for the flow and spray in inhalers and comparison with experiments.

**DISSERTATIONS**

-

**SCIENTIFIC PUBLICATIONS**

-

**PROJECTLEADERS**

HWM Hoeijmakers, FHC de Jongh

**RESEARCHTHEME**

Mathematical and computational methods for fluid flow analysis

**PARTICIPANTS**

FHC de Jongh, HWM Hoeijmakers

**COOPERATIONS**

MST, UVA-AMC, Medspray

**FUNDED**

UT	
University	100%
FOM	-
STW	-
NWO Other	-
Industry	-
TNO	-
GTI	-
EU	-
Scholarships	-

**START OF THE PROJECT**

1998

**INFORMATION**

FHC de Jongh  
053 489 4428  
f.h.c.dejongh@utwente.nl





Prof.dr.ir. ThH van der Meer

The research activities of the Thermal Engineering Group mainly concentrate on thermal conversion processes for industrial applications from the disciplines thermodynamics, transport phenomena and fluid mechanics. The research aims at an increasing use of renewable fuels, and at a more efficient and clean utilization of fossil fuels. The projects are organized around three central themes: thermal conversion processes of fuels, turbulent gaseous combustion and thermo-acoustics, and instationary heat transfer.

The research theme thermal conversion processes of fuels is part of the research programme of the OSPT (research school on process technology)

The research theme Turbulent gaseous combustion and thermo-acoustics is related to questions on ignition, extinction, flame stability, pollutant formation, combustion noise and its interaction with the combustion chamber structure. Numerical models are developed (within CFX), and experimental research is done like flow visualisation, acoustic measurements and laser diagnostics like laser induced fluorescence and Ramen/Rayleigh spectroscopy for the in-flame measurements of temperature and species concentrations. the underlying physical-chemical processes. Currently a large EU-project, named LIMOUSINE, with three PhD's and a post doc is ongoing on the topic of thermo-acoustics in gas turbines. Next there are several projects within the STW perspective program Clean Combustion Concepts.

The research theme "instationary heat transfer" is related to heat transfer in piston compressors, a pulsed compression reactor and new materials for enhanced heat transfer in regenerators and heat exchangers based on carbon nano-fibers attached to the heat transfer surface.

## PROJECT AIM

This project generates knowledge needed in the design and operation of ultra clean, efficient and reliable natural gas partial combustion systems to produce syngas. Computational fluid dynamics modeling is applied to predict fuel rich turbulent combustion at elevated pressure. The modeling involves prediction of major and minor chemical species, radiative heat loss and soot precursor species. These are linked to a soot formation and transport model for particle size distribution. Multiple combustion regimes are explored, The CFD model is validated by 6 bar/300 kW laboratory tests, including gas composition, soot particle size, nature and number density.

## PROGRESS

The reaction progress combustion model CFI is developed for ultra rich turbulent combustion of gaseous hydrocarbons at elevated pressures. In 2010 the modeling of the instantaneous chemical reaction source term using a single variable has been made accurate for rich conditions by implementation of a parameterized curve fit on basis of a laminar premixed flame calculation and a correlation for the flame speed as a function of equivalence ratio. Subsequently the chemistry model has been extended to include radiative heat loss by means of an additional scalar transport variable. The test rig has been made operational. A device has been developed and manufactured for sampling and diluting the flue gas with a view to particle measurement. A TSI particle sizing instrument has been purchased.

## DISSERTATIONS

-

## SCIENTIFIC PUBLICATIONS

-

## PROJECTLEADERS

JBW Kok

## RESEARCHTHEME

Mathematical and computational methods for fluid flow analysis

## PARTICIPANTS

M Woolderink, JBW Kok, ThH van der Meer

## COOPERATIONS

Shell Global Solutions Amsterdam, Aalborg Industries Nijmegen, Automotive Centre Eindhoven, DAF trucks, Ansys Abingdon

## FUNDED

STW, Shell Global Solutions Amsterdam	-
University	-
FOM	-
STW	-
NWO Other	85%
Industry	15%
TNO	-
GTI	-
EU	-
Scholarships	-

## START OF THE PROJECT

2009

## INFORMATION

JBW Kok

053 489 2582

[j.b.w.kok@utwente.nl](mailto:j.b.w.kok@utwente.nl)

[www.thw.ctw.utwente.nl](http://www.thw.ctw.utwente.nl)

## LIMOUSINE: LIMIT CYCLES OF PRESSURE OSCILLATIONS IN GAS TURBINE COMBUSTORS

### PROJECT LEADERS

JBW Kok

### RESEARCH THEME

Mathematical and computational methods for fluid flow analysis

### PARTICIPANTS

SK Tarband Veeraraghavan,  
JBW Kok, R Alemela,  
ThH van der Meer

### COOPERATIONS

Project in cooperation with DLR, CERFACS, Imperial College, Keele University, University of Zaragoza, University of Brno, Siemens Muelheim, Ifa Muenchen, Ansys Abingdon.

### FUNDED

European Union: Marie Curie ITN program  
University -  
FOM -  
STW -  
NWO Other -  
Industry 100%  
TNO -  
GTI -  
EU -  
Scholarships -

### START OF THE PROJECT

2008

### INFORMATION

JBW Kok  
053 489 2582  
j.b.w.kok@utwente.nl  
www.thw.ctw.utwente.nl

### PROJECT AIM

LIMOUSINE aims at the development of numerical tools to predict the chain of events leading to mechanical failure of gas turbine combustors due to limit cycles of low frequency pressure oscillations. Explored is the interaction and the feed back mechanisms between combustion dynamics, acoustics, aerodynamics and structural vibration. Essential is that not only the operating points with linear instability are identified, but also the nonlinear mechanisms leading to amplitude saturation.

### PROGRESS

In the project European wide 17 PhD students are active, coordinated by the University of Twente. At the UT 4 PhD students and one Post Doc are employed in the area of fluid mechanics, structural vibration and mechanical failure. Key element in the project is a UT designed generic lab scale combustor that is operated in limit cycle pressure oscillation. Numerical studies (CFD) for transient turbulent combustion in this combustor were performed. The numerical modeling used transient RANS methods taking into account acoustic phenomena and interaction with combustion. The simulations showed development of a limit cycle oscillation. The results were found to be dependent on the combustion model used. Further improvement is necessary on the implementation of the acoustic boundary conditions.

### DISSERTATIONS

-

### SCIENTIFIC PUBLICATIONS

1. Santosh Tarband Veeraraghavan, Reddy Alemela and Jim Kok, Dynamics of the bluff body stabilized flame in a model combustor using CFD, Proceedings of the 17th International Congress on Sound and Vibration (ICSV17), (CD-ROM proceedings) (ISBN: 978-83-60716-71-7), 2010.

# LIMOUSINE: LIMIT CYCLES OF PRESSURE OSCILLATIONS IN GAS TURBINE COMBUSTORS.

## PROJECT AIM

LIMOUSINE aims at the development of numerical tools to predict the chain of events leading to mechanical failure of gas turbine combustors due to limit cycles of low frequency pressure oscillations. Explored is the interaction and the feed back mechanisms between combustion dynamics, acoustics, aerodynamics and structural vibration. Essential is that not only the operating points with linear instability are identified, but also the nonlinear mechanisms leading to amplitude saturation.

## PROGRESS

In the project European wide 17 PhD students are active, coordinated by the University of Twente. At the UT 4 PhD students and one Post Doc are employed in the area of fluid mechanics, structural vibration and mechanical failure. Key element in the project is a UT designed generic lab scale combustor that is operated in limit cycle pressure oscillation. Laboratory tests were performed on a prototype combustor. This was found to operate in high amplitude limit cycle operation at 100 Hz. By means of laser vibrometer measurements this oscillation was shown to be related to a vibration on a wall eigenfrequency that coupled to the flame. A new combustor with a toolbox like assembly was designed and manufactured. Tests showed this operated very stable under all conditions and to very low fuel equivalence ratio as low as 0.3. This phenomenon is currently investigated. Preliminary tests show this to be caused by low mixing rates of fuel and air.

## DISSERTATIONS

-

## SCIENTIFIC PUBLICATIONS

1. Juan Carlos Roman Casado, Reddy Alemela and Jim Kok, Combustion Dynamics coupled to Structural Vibration, Proceedings of the 17th International Congress on Sound and Vibration (ICSV17), (CD-ROM proceedings) (ISBN: 978-83-60716-71-7).

## PROJECT LEADERS

JBW Kok

## RESEARCH THEME

Mathematical and computational methods for fluid flow analysis

## PARTICIPANTS

JC Roman Casado, JBW Kok, R Alemela, ThH van der Meer

## COOPERATIONS

Project in cooperation with DLR, CERFACS, Imperial College, Keele University, University of Zaragoza, University of Brno, Siemens Muelheim, Ifta Muenchen, Ansys Abingdon.

## FUNDED

European Union: Marie Curie ITN program

University	-
FOM	-
STW	-
NWO Other	-
Industry	100%
TNO	-
GTI	-
EU	-
Scholarships	-

## START OF THE PROJECT

2008

## INFORMATION

JBW Kok  
053 489 2582  
j.b.w.kok@utwente.nl  
www.thw.ctw.utwente.nl

## LIMOUSINE: LIMIT CYCLES OF PRESSURE OSCILLATIONS IN GAS TURBINE COMBUSTORS.

### PROJECT LEADERS

JBW Kok

### RESEARCH THEME

Mathematical and computational methods for fluid flow analysis

### PARTICIPANTS

M Kapucu, JBW Kok, R Alemela, ThH van der Meer

### COOPERATIONS

Project in cooperation with DLR, CERFACS, Imperial College, Keele University, University of Zaragoza, University of Brno, Siemens Muelheim, Ifa Muenchen, Ansys Abingdon.

### FUNDED

European Union: Marie Curie ITN program

University	-
FOM	-
STW	-
NWO Other	-
Industry	100%
TNO	-
GTI	-
EU	-
Scholarships	-

### START OF THE PROJECT

2008

### INFORMATION

JBW Kok

053 489 2582

j.b.w.kok@utwente.nl

www.thw.ctv.utwente.nl

### PROJECT AIM

LIMOUSINE aims at the development of numerical tools to predict the chain of events leading to mechanical failure of gas turbine combustors due to limit cycles of low frequency pressure oscillations. Explored is the interaction and the feed back mechanisms between combustion dynamics, acoustics, aerodynamics and structural vibration. Essential is that not only the operating points with linear instability are identified, but also the nonlinear mechanisms leading to amplitude saturation.

### PROGRESS

In the project European wide 17 PhD students are active, coordinated by the University of Twente. At the UT 4 PhD students and one Post Doc are employed in the area of fluid mechanics, structural vibration and mechanical failure. Key element in this project is the UT 100 kW/bar, 1-5 bar combustor that is operated with preheated air. Target is to bring the combustor in limit cycle pressure oscillation and investigate the saturated amplitude behaviour. An acoustic network model has been brought to very accurate prediction in the stable operating case. The boundary conditions depend on the flow condition and have been shown to be very important.

### DISSERTATIONS

-

### SCIENTIFIC PUBLICATIONS

1. Pozarlik, A., Kok, J.B.W., Numerical prediction of combustion induced vibro-acoustical instabilities in a gas turbine combustor., Proceedings of the 16th International Congress on Sound and Vibration (ICSV16), (CD-ROM proceedings) (ISBN: 978-83-60716-71-7).

# FLUISTCOM: 2-WAY WALL/FLUID INTERACTION IN GAS TURBINE COMBUSTORS

## PROJECT AIM

FLUISTCOM investigates the fundamental scientific aspects in the field of fluid-structure interaction for turbulent combustion systems. The project is motivated by the recent push towards leaner combustion technologies and reduced emissions. Such lean premixed combustion systems are prone to thermo-acoustic instabilities that can induce intolerable vibrations of the chamber walls.

## PROGRESS

Key element in this project is the UT 100 kW/bar, 1-5 bar combustor that is operated with preheated air. Coupled simulations are performed of the flow in the combustor and the vibrating liner structure. Taken into account are acoustic effects, combustion and two way interaction. The simulations are validated by laboratory test runs.

## DISSERTATIONS

1. A. Pozarlik: Vibro-acoustical instabilities induced by combustion dynamics in gas turbine combustors.

## SCIENTIFIC PUBLICATIONS

1. Pozarlik, A., Kok, J.B.W., Experimental investigation of the thermo-acoustic instabilities coupled with wall vibrations, Proceedings of the 17th International Congress on Sound and Vibration (ICSV17), (CD-ROM proceedings) (ISBN: 978-83-60716-71-7), 2010 .

## PROJECT LEADERS

JBW Kok

## RESEARCH THEME

Mathematical and computational methods for fluid flow analysis

## PARTICIPANTS

A Pozarlik, JBW Kok,  
ThH van der Meer

## COOPERATIONS

Project in cooperation with DLR, CERFACS, CIMNE, Queen's College Belfast, Siemens

## FUNDED

European Union: Marie Curie ITN program

University	-
FOM	-
STW	-
NWO Other	-
Industry	100%
TNO	-
GTI	-
EU	-
Scholarships	-

## START OF THE PROJECT

2004

## INFORMATION

JBW Kok

053 489 2582

[j.b.w.kok@utwente.nl](mailto:j.b.w.kok@utwente.nl)

[www.thw.ctw.utwente.nl](http://www.thw.ctw.utwente.nl)

**PROJECT LEADERS**

JBW Kok

**RESEARCH THEME**

Complex dynamics of fluids

**PARTICIPANTS**

U Lekic, JBW Kok,  
ThH van der Meer

**COOPERATIONS**

Oxford University, Ansys, Stirling  
Cryogenics, Thales Cryogenics,  
Grasso

**FUNDED**

STW, Ansys, Stirling Cryogenics,  
Thales Cryogenics, Grasso  
University -  
FOM -  
STW -  
NWO Other 90%  
Industry 10%  
TNO -  
GTI -  
EU -  
Scholarships -

**START OF THE PROJECT**

2005

**INFORMATION**

JBW Kok  
053 489 2582  
j.b.w.kok@utwente.nl  
www.thw.ctw.utwente.nl

**PROJECT AIM**

The aim of the project is the formulation of design rules for unlubricated PCC's derived from experiments and numerical simulations. Numerical models are developed to provide a better understanding of matched materials in a PCC and their response under given circumstances. The numerical research combines Finite Element Methods (FEM) and Computational Fluid Dynamics (CFD) methods in an integrated approach for both the working fluid behaviour and the solid wall behaviour during compression and expansion in start-up and nominal operating conditions.

**PROGRESS**

Experimental and numerical results are postprocessed. Correlations were made between instantaneous heat flux and the pressure temperature history induced by the piston motion. Results are interpreted against the background of thermodynamics. The PhD thesis has been written.

**DISSERTATIONS**

-

**SCIENTIFIC PUBLICATIONS**

1. Lekic, U., Kok, J.B.W., Heat transfer and fluid flows in gas springs, Open Thermodynamics Journal, pp.13-26 (14), ISSN: 1874-396X, 2010.

**PROJECT AIM**

A numerical study investigates a new heat exchanger material existing of a fine metallic structure, e.g. a metallic foam. The surface of this material carbon is covered with carbon nano fibers (CNF's). These fibers influence the fluid flow, and enlarge the heat exchanging surface. Preliminary experimental research has shown that the presence of these CNF's can enhance heat transfer by 50%. This depends very much on the CNF density and on the structure of the CNF itself. This numerical study gives directions in optimizing this new material.

**PROGRESS**

A stochastic model for three-dimensional CNF's structural description is developed. This model takes into account concentration, diameter, orientation angle and length of the fibers, for a each fiber independently. A three-dimensional fluid-dynamic and thermal-dynamic numerical code including heat transfer has been developed for the prediction of the thermal behavior of the CNF's attached to a wall using the lattice Boltzmann equation. The predicted thermal behavior of the CNF's shows that there is a high heat transfer enhancement through the CNF's layer. It has also been shown that conductive heat transfer has a dominant effect on heat transfer from air through the CNF's to the wall. For a volume percentages of the CNF's up to 23 % the increased heat flux appears to be linear.

**DISSERTATIONS**

-

**SCIENTIFIC PUBLICATIONS**

1. N. Pelevic, Th. H. van der Meer, Boundary conditions for the three – dimensional thermal lattice Boltzmann method and its application to flows with heat transfer in a rectangular micro-channel, Proceedings of 19th Discrete Simulation of Fluid Dynamics Conference, Rome, Italy, 2010.
2. N. Pelevic, Th. H. van der Meer, Numerical modeling of new heat exchangers materials, Proceedings of the 14th International Heat Transfer Conference, Washington, USA, 2010.

**PROJECTLEADERS**

ThH van der Meer

**RESEARCHTHEME**

Complex dynamics of fluids

**PARTICIPANTS**

N Pelevic

**COOPERATIONS**

-

**FUNDED**

SenterNovem, ATAG

University -

FOM -

STW -

NWO Other 50%

Industry 50%

TNO -

GTI -

EU -

Scholarships -

**START OF THE PROJECT**

2008

**INFORMATION**

ThH van der Meer

053 489 2562

t.h.vandermeer@utwente.nl



#### PROJECT LEADERS

ThH van der Meer

#### RESEARCH THEME

Complex dynamics of fluids

#### PARTICIPANTS

T Roestenberg

#### COOPERATIONS

EnConTech BV, Shell Global Solutions

#### FUNDED

Senter Novem University -  
FOM -  
STW -  
NWO Other -  
Industry 100%  
TNO -  
GTI -  
EU -  
Scholarships -

#### START OF THE PROJECT

2007

#### INFORMATION

ThH van der Meer  
053 489 2562  
t.h.vandermeer@ctw.utwente.nl

#### PROJECT AIM

Production processes of base chemicals such as synthetic gas, ethylene or acetylene, take place at high temperatures and are currently very energy-intensive and inefficient. A new reactor type promises a breakthrough in the energy efficiency, capital costs and mobility of these production processes. The novel pulsed compression technology that is under investigation in this project has been proven in a "proof of principle reactor". However, run times of longer than approximately 30 sec were not attainable. This project aims to supply the required knowledge about the heating of both reactor and piston, to achieve run times in the order of one hour.

#### PROGRESS

A new reactor, specifically designed for the investigation of thermo dynamical effects in the novel pulsed compression reactor, has been constructed. The new reactor incorporates various techniques for measuring temperature and pressure fluctuations at various positions in the reactor. The reactor has been used to generate a large database of measurements. Various parameters that influence the process in the reactor have been investigated.

#### DISSERTATIONS

-

#### SCIENTIFIC PUBLICATIONS

1. Oral presentation ICCEE 2010, Bali. Presentation title: "Pulsed compression technology: A breakthrough in chemical engineering".
2. Roestenberg, T., Glushenkov, M.J., Kronberg, A.E., Krediet, H.J., vd Meer, Th.H., "Heat transfer study of the pulsed compression reactor", Chemical engineering science, 65 (2010) 88-91.
3. Roestenberg, T., Glushenkov, M.J., Kronberg, A.E., vd Meer, Th.H., "On the controllability and run-away possibility of a totally free piston, pulsed compression reactor", Chemical engineering science, 65 (2010) 4916-4922.
4. Roestenberg, T., Glushenkov, M.J., Kronberg, A.E., vd Meer, Th.H., "Experimental study and simulation of syngas generation from methane in the Pulsed Compression Reactor", Fuel, article in press, doi:10.1016/j.fuel.2010.11.002.

**PROJECT AIM**

The aim of the project is to study in depth the effect of carbon nano-fibers deposited on heat transfer surface for heat transfer to/ from a fluid. At first materials will be synthesized in a very controlled manner by growing carbon nano-fibers with in situ measurements of the weight increase and the heat of reaction of the synthesis process. Heat transfer to/from the new materials will be determined experimentally. Structural and morphological effect of the CNFs on heat transfer will be studied and optimal configuration will be derived. A production facility for the synthesis of carbon nano-fibers will be designed and built. Finally the performance of the new materials can be determined at ECN in test rigs of a thermo-acoustic and a thermo-chemical heat pump.

**PROGRESS**

Heat transfer measurement procedures are formulated. Small cylindrical surfaces are chosen as heat transfer surfaces to measure convective heat transfer coefficient and compare results from with and without carbon nano-fibers. Heat transfer set-up is designed and currently is under construction. Using catalytic vapor deposition technique, successful synthesis of carbon nano-fibers on the surface of the nickel wire is made but parameter adjustments for different morphologies and topologies of the carbon nano-fibers are still under investigation.

**DISSERTATIONS**

-

**SCIENTIFIC PUBLICATIONS**

-

**PROJECTLEADERS**

ThH van der Meer

**RESEARCHTHEME**

Complex dynamics of fluids

**PARTICIPANTS**

TJ Taha, ThH van der Meer

**COOPERATIONS**

ECN

**FUNDED**

EL&I

University -

FOM -

STW -

NWO Other -

Industry 100%

TNO -

GTI -

EU -

Scholarships -

**START OF THE PROJECT**

2010

**INFORMATION**

TJ Taha

053 489 2559

t.j.taha@ctw.utwente.nl

**PROJECT LEADERS**

ThH van der Meer

**RESEARCH THEME**

Complex dynamics of fluids

**PARTICIPANTS**

AA Verbeek

**COOPERATIONS**

Dr.ir. RJM Bastiaans, Prof.dr.ir. BJ Geurts

**FUNDED**

STW, Electrabel Nederland,  
Laborelec, Ansys Germany, TTS/  
Ansaldo  
University -  
FOM -  
STW -  
NWO Other 90%  
Industry 10%  
TNO -  
GTI -  
EU -  
Scholarships -

**START OF THE PROJECT**

2010

**INFORMATION**

ThH van der Meer  
053 489 2562  
t.h.vandermeer@ctw.utwente.nl

**PROJECT AIM**

The idea of this project is to optimize low swirl burners by adding resonant mixing perturbations. To that end both practical and fundamental research is needed. Physical experiments are crucial to find out a priori the resonant regimes in actual combustors under realistic conditions, in which the low swirl stabilization concept works with good specifications. The experiments will provide data for validation of the findings of the numerical simulations. Numerical simulation by means of DNS and LES, is an essential tool to understand the complex flame dynamics.

**PROGRESS**

Literature review: Low swirl burner and resonant turbulence phenomenon  
Design Low Swirl Burner with a turbulence generator that is capable of modulating energy feed. Setting up measurement techniques:

- Single probe Constant Temperature Anemometry
- CH and OH flame chemiluminescence
- OH PLIF for flame surface density measurements

**DISSERTATIONS**

-

**SCIENTIFIC PUBLICATIONS**

-

# HITAC BOILER: HEAVY FUEL-OIL COMBUSTION IN A HITAC BOILER

## PROJECT AIM

The objectives of this project is to investigate computationally the combustion of heavy fuel oil with high temperature air in conditions representative for oil combustion in a boiler, and the spray combustion models will be developed and validated by literature flame, the Delft flame in the laboratory and an industrial test of combustion in a 9 MW boiler. Knowledge of these will be used to exploit the principles of HiTAC to create conditions with low NOX formation, uniform heat flux and to optimize the water-steam cycle to create an economically attractive, robust and reliable boiler system.

## PROGRESS

Theories and literature related to discretisation techniques, meshing, turbulence models, combustion models, spray models, and measuring techniques were studied. Experimental data obtained by John F. Widmann and Cary Presser at the National Institute of Standards and Technology (NIST) were chosen for validation of spray combustion models. In the simulation of the NIST flame, the features of this case and the previous research were studied and analyzed. The meshing method, finite difference scheme, and the near-wall treatment are discussed in order to obtain a better prediction of the turbulence. The boundary conditions, such as inlet air velocity components, heat transfer through the walls, radial location of the spray, and the droplet diameter distribution were analyzed and discussed based on the experimental data. With the Linearized Instability Sheet Atomization model (LISA) for atomization and Eddy Dissipation model (EDM) for combustion, the sensitivities of the dispersion angle, sheet constant and ligament constant and their influences on the predicted results were investigated. Moreover, besides EDM, the flamelet model with the detailed reaction mechanism of methanol was employed for the simulation. Knowledge of these models will be used in the subsequent simulation of the Delft flame under HiTAC condition, and will be extended for heavy fuel oil.

## DISSERTATIONS

-

## SCIENTIFIC PUBLICATIONS

-

## PROJECT LEADERS

ThH van der Meer

## RESEARCH THEME

Mathematical and computational methods for fluid flow analysis

## PARTICIPANTS

S Zhu

## COOPERATIONS

TU Delft, Stork Thermeq, Shell Global Solutions Int.

## FUNDED

STW, Nederlandse Vlamvereniging University	-
FOM	-
STW	100%
NWO Other	-
Industry	-
TNO	-
GTI	-
EU	-
Scholarships	-

## START OF THE PROJECT

2009

## INFORMATION

ThH van der Meer

053 489 2562

t.h.vandermeer@utwente.nl

## MULTI SCALE MECHANICS (MSM)



Prof.dr.rer.nat. S Luding

The group Multi Scale Mechanics (MSM) is part of the Mechanical Engineering department, and the Engineering Fluid Dynamics group, with MSM-research in the areas of multi-scale fluid- and solid mechanics, micro-macro approaches, particle and contact mechanics, micro-fluidics, and self-healing materials. Multi Scale Mechanics deals with fluids and solids, where various physical phenomena take place at different length-scales at the same time. Thus, Multi Scale Mechanics can involve very small and very large objects, very fast and very slow processes. Starting from atoms, the meso-scale with domains and particles is the next larger level and buildings, machines and constructions are the large structures involved. How does the mechanics on the small level affect the behavior at the larger levels? Micro-Macro theory is one way to predict and describe this, but also advanced numerical simulations help us to understand this. Thus, for application, Multi Scale Mechanics is needed to understand modern, advanced materials. Involving theory, numerical simulation and experiments for validation, these research results can then be used to optimize the design and the efficiency of buildings, machines, and materials.

### PROJECT AIM

The project's broad goal is to understand the effect of microscopic particle properties on the macroscopic continuum behavior of granular materials. The long term objective is to devise a physically based constitutive model which depends explicitly on a limited set of these parameters.

### PROGRESS

In connection with our previous study on isotropic compression of polydisperse packings of spheres, we performed triaxial test simulations using DEM to analyze the effect of polydispersity and particle friction on the macroscopic behavior of granular packings. An increase in polydispersity leads to a decrease in confining pressure at constant volume fraction, after isotropic compression, and macroscopic friction increases with particle friction. We systematically calibrated a simple hypoplastic constitutive model with the numerical test results to determine the dependence of material parameters of the model on the polydispersity and friction of the particles. A clear trend is observed in a certain material coefficient with increasing friction. The effect of polydispersity on material coefficients depends on initial packing conditions i.e. whether they are prepared at constant initial volume fraction or constant initial pressure.

### DISSERTATIONS

-

### SCIENTIFIC PUBLICATIONS

1. F. Göncü, O. Duran, and S. Luding. Constitutive relations for the isotropic deformation of frictionless packings of polydisperse spheres, [ C. R. Mecanique 338 (10-11), 570-586, 2010 ].
2. F. Göncü and S. Luding. From ``soft'' particle simulations to macroscopic constitutive relations World Congress Particle Technology 6, Nuremberg, CD-Proceedings, 4 pages, Nürnberg Messe GmbH (Ed.), March 2010, ISBN-978-3-00-030570-2.

### PROJECT LEADERS

S Luding

### RESEARCH THEME

Mathematical and computational methods for fluid flow analysis

### PARTICIPANTS

F Göncü, S Luding

### COOPERATIONS

-

### FUNDED

Delft Center for Computational Science and Engineering (DCSE)

University 100%

FOM -

STW -

NWO Other -

Industry -

TNO -

GTI -

EU -

Scholarships -

### START OF THE PROJECT

2008

### INFORMATION

F Goncu

053 489 2694

f.goncu@utwente.nl

**PROJECT LEADERS**

S Luding

**RESEARCH THEME**

Complex dynamics of fluids

**PARTICIPANTS**

RM Hartkamp, A Ghosh, S Luding

**COOPERATIONS**

B.D. Todd (Swinburne University of Technology), P.J. Davis (RMIT), S. Bernardi (Griffith University), A.P. Markesteijn (TUD)

**FUNDED**

MicroNed	
University	50%
FOM	-
STW	-
NWO Other	-
Industry	50%
TNO	-
GTI	-
EU	-
Scholarships	-

**START OF THE PROJECT**

2006

**INFORMATION**

S Luding  
053 489 4212  
s.luding@utwente.nl

**PROJECT AIM**

During the past few years molecular dynamics has been a widely applied tool to simulate fluid confined in micro/nano geometries. What makes interfacial fluids fundamentally different from the bulk fluid is the fact that their density varies considerably over microscopic distances. A class of such strongly inhomogeneous fluids are those confined in very narrow spaces by solid boundaries. In the present project the goal is to study the transport properties of such fluids, investigate the effect of wall-fluid interaction, surface roughness and wall-morphology on the flow behavior.

**PROGRESS**

In this project we simulate planar Poiseuille flow of a Lennard-Jones fluid in channels of various widths in the nanoscale regime. Furthermore, the flow properties in channels with various boundary conditions, body forces, densities and temperatures are compared. We obtain average stress and strain profiles across the channel and the local viscosity can be estimated from stress-strain relations as function of density. Anisotropic stress is found near the walls of the channel; the influence of various parameters on the anisotropy are studied. Understanding and quantifying the non-Newtonian behavior is a first step towards deriving a constitutive model that governs the behavior of a strongly confined fluid. A constitutive framework is proposed in order to quantify the relation between the stress tensor and strain rate, temperature, density and other profiles.

**DISSERTATIONS**

-

**SCIENTIFIC PUBLICATIONS**

1. R.M. Hartkamp and S. Luding, "A continuum approach applied to a strongly confined Lennard-Jones fluid", Fifth International Conference on Multiscale Materials Modeling. Freiburg, Germany, October 2010.
2. R.M. Hartkamp and S. Luding, "Anisotropic Lennard-Jones fluids in a nanochannel", International Conference on Multiphase Flow. Tampa, Florida, May 2010.
3. R.M. Hartkamp, A. Ghosh and S. Luding, "Wall-induced order in anisotropic Lennard-Jones fluid in a nanochannel", World Congress Particle Technology 6, Nuremberg, 4 pages, CD-Proceedings, April 2010.

**PROJECT AIM**

The goal is to obtain quantitative agreements between element test experiments and DEM simulations for cohesive powders. Element tests are small laboratory tests that allow measuring and classifying the bulk behavior of powder systems with a control of the stress-strain path. Only when this agreement is established, the way to various applications in powder transport or processing is open. There is an established procedure for dry powders, but bears many challenges for sticky, cohesive powders like those relevant in the food industry.

**PROGRESS**

The Discrete element method (DEM) is used to simulate the strain-controlled Uniaxial compression of frictionless polydisperse spheres above the jamming volume fraction in a biaxial box. A simple linear viscoelastic contact model is used and the evolution of coordination number, fraction of rattlers as a function of volume fraction has been studied. Also, analytical prediction of the scaled pressure as a function of volumetric strain for an isotropic system compares well with our uniaxial simulation for different polydispersities where the particles are frictionless. Concerning anisotropy, we study the evolution of the first deviatoric stress (between the fixed periodic walls) and the second deviatoric stress (between the horizontal and the vertical plane). From the evolution of anisotropy, typical system bulk properties (stiffness and friction coefficient can be seen. From this, bulk properties measured from laboratory experiments including stiffness and friction coefficient can be validated. The ongoing challenge is to implement more realistic contact models and perform experiments. In the future, the challenge is to theoretically describe the behaviour of these materials under different deformation modes. We will theoretically study the deviatoric fabric (anisotropy) and compare results with numerical simulations.

**DISSERTATIONS**

-

**SCIENTIFIC PUBLICATIONS**

-

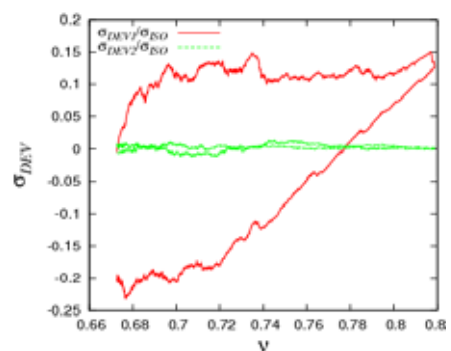
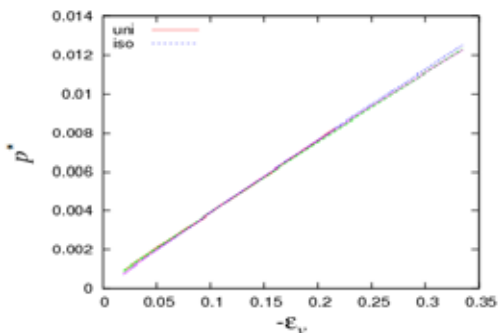

Plot of the scaled pressure as a function of the (negative) volumetric strain for an isotropic and uniaxial dataset (left) and the evolution of the first and second deviatoric stress as a function of the volume fraction (right).

**PROJECT LEADERS**

S Luding

**RESEARCH THEME**

Complex dynamics of fluids

**PARTICIPANTS**

O Isaiah Imole, N Kumar

M Wojtkowski

**COOPERATIONS**

Nestle Research Center, Switzerland

TU Braunschweig, UT Compiègne

**FUNDED**

EU Marie Curie Initial Training

Network

University -

FOM -

STW -

NWO Other -

Industry -

TNO -

GTI -

EU 100%

Scholarships -

**START OF THE PROJECT**

2010

**INFORMATION**

O Isaiah Imole

053 489 3061

[o.i.imole@utwente.nl](mailto:o.i.imole@utwente.nl)



**PROJECT LEADERS**

S Luding, M Ramioli

**RESEARCH THEME**

Mathematical and computational methods for fluid flow analysis

**PARTICIPANTS**

M Robinson

**COOPERATIONS**

Nestlé Research Center

**FUNDED**

Marie Curie Initial Training Network

University -

FOM -

STW -

NWO Other -

Industry -

TNO -

GTI -

EU 100%

Scholarships -

**START OF THE PROJECT**

2010

**INFORMATION**

M Robinson

050 750 1449

m.j.robinson@ctw.utwente.nl

**PROJECT AIM**

A validated CFD-DEM simulation will be developed and used to analyse the decompaction and dispersion of the powder bed by a water jet. For a wet particle bed, the challenges will include the correct modelling of the liquid-particle coupling over a wide range of porosities. For the dry particle bed there will also be a wide range of particle saturation (relative ratio of interstitial liquid and air). We wish to determine which operating conditions give rise to particular dynamical regimes and to understand the temporal and spatial distribution of the particles in the cell.

**PROGRESS**

A two-way coupled SPH-DEM simulation tool has been developed, based on the locally averaged NS equations by Anderson and Jackson (1967). This has been applied to single and multiple particle sedimentation test problems. Some initial simulations of a water jet impacting on a granular bed have been performed. The relative strengths of the various drag terms (eg. Added mass force, history force, lift force etc) have been compared using a simple analytical model and the same physical parameters as the experimental results.

**DISSERTATIONS**

-

**SCIENTIFIC PUBLICATIONS**

-

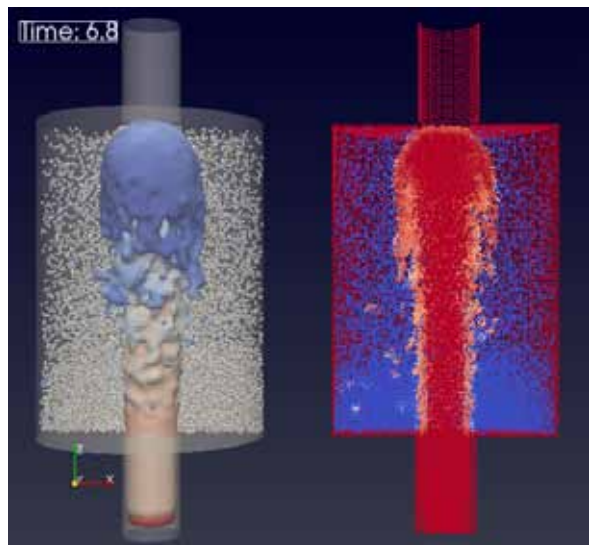

SPH-DEM simulation of a water jet impacting on a granular bed. Constant velocity fluid inlet from the bottom of the cell. Left: water free surface coloured by velocity. Right: SPH and DEM particles coloured by porosity

**PROJECT AIM**

To probe the connections between jamming, shear banding and microstructures in numerical simulations of Brownian and non-Brownian systems with various interaction forces, shear rates, stress regimes.

**PROGRESS**

DEM simulations are being used to study the shear banding in “split bottom ring shear cell” where a slow, quasi-static deformation leads to wide shear bands which are away from side walls. From a single simulation, by applying averaging continuum quantities can be computed. The typical characteristic of quasi-static system is rate-independence. For different driving rates the system is validated to be rate independent. Yield locus for different driving rates are found to collapse on top of each other. Contact friction on the other hand is found to increase the strength of the material. While contact adhesion leads to a non-linear and pressure dependent yield locus, which is found to grow with adhesion. To study this, statistical analysis for force and overlap is done.

**DISSERTATIONS**

-

**SCIENTIFIC PUBLICATIONS**

1. A. Singh and S. Luding, Flow behavior at different shear rates for dry powders, WCPT6, Nuremberg, Nürnberg Messe GmbH (Ed.), March 2010, ISBN-978-3-00-030570-2.
2. A. Singh and S. Luding, Effect of contact-cohesion on wide shear bands, “Does Dimensionality Matter?”, MPIPKS, Dresden, Germany. (Poster)
3. A. Singh, V. Magnanimo and S. Luding, Micro-structure analysis in shear bands for cohesive-frictional powder, Disorder and Heterogeneity in Physics 2010, Santiago, Chile. (Oral talk and Poster).

**PROJECT LEADERS**

S Luding

**RESEARCH THEME**

Complex dynamics of fluids

**PARTICIPANTS**

A Singh, V Magnanimo, A Thornton

**COOPERATIONS**

AR Thornton

**FUNDED**

FOM	
University	-
FOM	100%
STW	-
NWO Other	-
Industry	-
TNO	-
GTI	-
EU	-
Scholarships	-

**START OF THE PROJECT**

2009

**INFORMATION**

A Singh  
053 489 2694  
A.Singh@ctw.utwente.nl

Termination Locus for increasing contact adhesion (Left), and contact friction (Right) between particles

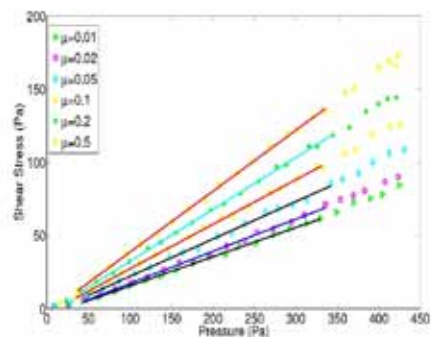
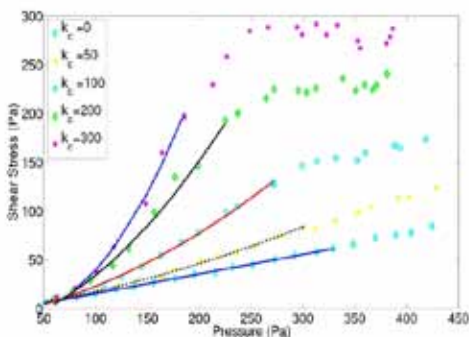

**PROJECT LEADERS**

S Luding

**RESEARCH THEME**

Mathematical and computational methods for fluid flow analysis

**PARTICIPANTS**

S Srivastava, K Yazdchi

**COOPERATIONS**

Ingelheim Boehringer Germany, University of Magdeburg, CSIRO Australia

**FUNDED**

STW (Project No. 10120)  
 University -  
 FOM -  
 STW 100%  
 NWO Other -  
 Industry -  
 TNO -  
 GTI -  
 EU -  
 Scholarships -

**START OF THE PROJECT**

2009

**INFORMATION**

S Srivastava  
 053 489 3345  
 s.srivastava@utwente.nl  
 www.utwente.nl/ctw/mmsm

**PROJECT AIM**

The goal of this project is to develop a multi-scale computational framework for modeling fluid-particle interactions for industrially relevant problems e.g. flow through porous media and fluidized beds. The key component of this framework is a Delaunay triangulation which is used as both an efficient contact detection tool for moving particles and for solving flow using unstructured finite element method. This approach reduces the data structure and computational overhead for storing both particles and triangulation and provides efficient coupling between particle motions and fluid flow.

**PROGRESS**

Multi-scale modeling of many common industrial systems e.g. fluidized beds; flow in porous media involve fluid-particle interactions. A new method of coupling fluids with particles using Delaunay triangulation is presented. Delaunay triangulation is a simple and efficient tool for detecting contact in granular/particulate media simulations using the Discrete Element Method (DEM). We utilize this triangulation for simultaneously solving the continuum equations of fluid dynamics using stabilized higher order finite element Method (FEM) on a moving mesh. Thus, our mesh serves a two-fold purpose in the simulation and provides a natural setting for multi-scale coupling between fluid and particles. A salient computational feature of our methodology is that both fluid and particles data are stored in a single hierarchical data structure (i.e. the triangulation). The momentum exchange between fluid and particles is based on various empirical drag model(s) which allows for explicit coupling between fluid and particles. Our coarse triangulation is also suitable for FEM with moving nodes (particles) since it is often more robust with respect to mesh distortion. Using numerical examples we compute permeability of the media and validate our results with fully resolved FEM simulations.

**DISSERTATIONS**

-

**SCIENTIFIC PUBLICATIONS**

1. K. Yazdchi, S. Srivastava and S. Luding, On the transition from creeping to inertial flow in arrays of cylinders, Proceedings of IMECE, 2010, Vancouver, British Columbia, Canada.
2. K. Yazdchi, S. Srivastava and S. Luding, Multi-Scale permeability of particulate and porous media, World Congress on Particle Technology 6, 2010, Nuremberg, Germany.

(a) A snapshot of the coarse Delaunay mesh with particles at triangle vertices. (b) Fluid flow through a 5x5 array of circular disks using our approach. (c) Comparison of average flow obtained in (b) with fine mesh simulations in Ansys

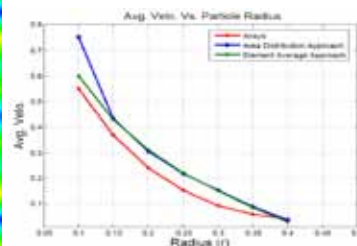
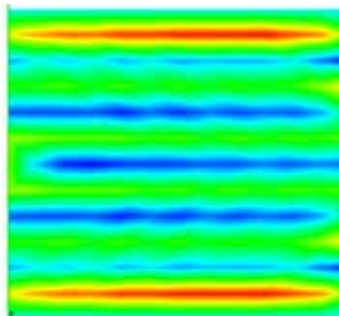
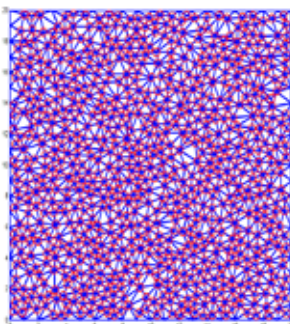

## PROJECT AIM

The primary propose of the project is to develop a new HMM model for granular flow, coupling a micro-scale discrete element model to the macro-scale continuum granular flow model. The new model will be verified through some test cases where closures are known experimentally or theoretically, such as for dry granular flows in a uniform channel with a rough bottom. Additionally, an investigation of segregation in granular flows will be undertaken.

## PROGRESS

Both micro- and macroscale models for granular flow have been developed and implemented. The microscale model consists of a Discrete Element model (DEM) governed by Newtonian mechanics, whereas the macroscale model is a Discontinuous Galerkin finite element solver built on the in-house HPGEM package. To compare the DEM simulation results with continuum models a course-graining (CG) function is used. During this year, a thorough investigation of CG kernels (statistics), with particular attention to the boundaries of the flow, has been undertaken revealing new insights. There are currently several publications in preparation from this project on the DEM statistics, friction laws across variable bottom roughness and comparison of segregation rates between theory and DEM.

## DISSERTATIONS

-

## SCIENTIFIC PUBLICATIONS

-

## PROJECTLEADERS

O Bokhoven

## RESEARCHTHEME

Mathematical and computational methods for fluid flow analysis

## PARTICIPANTS

T Weinhart, AR Thornton

## COOPERATIONS

-

## FUNDED

Institute of Mechanics, Processes and Control, Twente (IMPACT)

University 100%

FOM -

STW -

NWO Other -

Industry -

TNO -

GTI -

EU -

Scholarships -

## START OF THE PROJECT

2009

## INFORMATION

S Luding

053 489 4212

s.luding@utwente.nl

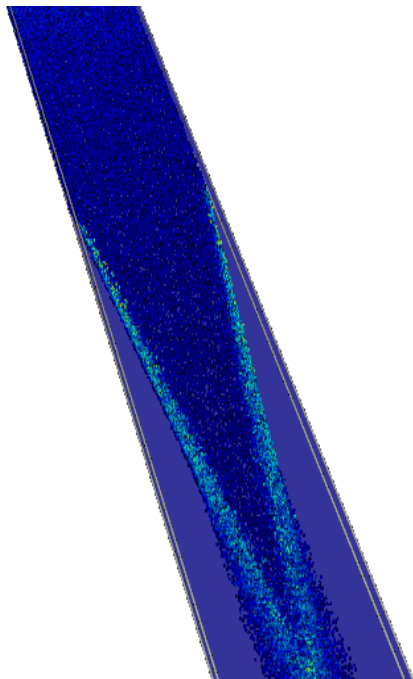

DEM simulation with 400,000 particles, color indicating flow height. Flow of granular materials through a contraction; two shocks are generated on either side of the contraction and interact at a triple point.

**PROJECT LEADERS**

S Luding

**RESEARCH THEME**

Complex dynamics of fluids

**PARTICIPANTS**

N Kumar, Ol Imole, M Wojtkowski

**COOPERATIONS**

NESTLE, DEM Solutions, ITASCA

**FUNDED**

EU

University -

FOM -

STW -

NWO Other -

Industry -

TNO -

GTI -

EU 100%

Scholarships -

**START OF THE PROJECT**

2010

**INFORMATION**

N Kumar

053 489 3061

n.kumar@ctw.utwente.nl

**PROJECT AIM**

The focus of this project is the determination of macroscopic models and constitutive laws from the microscopic DEM simulations. Only when a procedure for this is established, the way to applications in powder transport or processing is feasible. The bulk behavior of powder systems depends on the contact properties of their constituents. Only in few cases, it is possible to perform the “micro-macro transition” from contact properties to continuum quantities.

**PROGRESS**

An analytical expression for the pressure as function of physical strain (not classical) is proposed for poly-disperse packings, assuming uniform deformation. Comparison of analytical expressions for different types of compression modes is also conducted which agrees with the theoretical predictions. Application of deviatoric (or shear) strain lead to the structural anisotropy in the system. Evolution of pressure as well as deviatoric stresses is related to the anisotropy of the structure which confirms the scaling relation of the fabric in presence of friction. Pressure dependency on the bulk-modulus is also done in this work. Dependency of loading cycle on critical parameters such as jamming volume fraction is also studied. Trace of fabric tensor as a function of size distribution for isotropic compression and its deviation for the case of uniaxial and deviatoric are also studied. Concerning anisotropy, the challenge is to compare the numerical simulation with the developed theory. It needs to be done to see the evolution of the deviatoric stresses and normalized deviatoric stresses with the deviatoric fabric and deviatoric strain.

**DISSERTATIONS**

-

**SCIENTIFIC PUBLICATIONS**

-

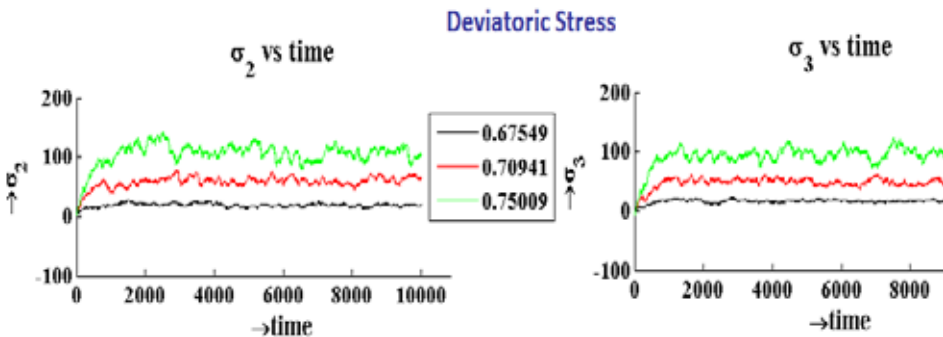

2nd and 3rd deviatoric stresses for deviatoric experiments at different initial volume fractions

### PROJECT AIM

Goal of the project is to develop a multi-scale computational method that uses a single hierarchical data-structure as basis – involving also multiple fields. Starting from meso-scopic structures (particles or domains) a grid is constructed on a hierarchical, tree-based data structure. The hierarchical approach allows for micro-macro transition, coupling of different fields, and coarsening or refinement – where possible or needed, respectively.

### PROGRESS

A novel method for contact detection for arbitrary particle size distributions is developed and confirmed by DEM simulations. It has applications in computer simulations of widely distributed in particle size materials, like for example, concrete, powders, mixtures. With proposed contact detection method we investigate numerically the effect of polydispersity on pressure in a system. The global equation of state for polydisperse spheres is derived from J. T. Jenkins' bi-disperse equation. The theoretical bounds for pressure in polydisperse systems are obtained.

### DISSERTATIONS

-

### SCIENTIFIC PUBLICATIONS

1. V. Ogarko, S. Luding, Data structures and algorithms for contact detection in numerical simulation of discrete particle systems, in: Proceedings of the 6th World Congress on Particle Technology WCPT6, Nuremberg, 2010.

### PROJECT LEADERS

S Luding

### RESEARCH THEME

Complex dynamics of fluids

### PARTICIPANTS

V Ogarko, K Yazdchi, S Srivastava

### COOPERATIONS

Prof. Dr. Hans Kuipers, DEM solutions (Dr. John Favier), CeParTec GmbH (Dr. Torsten Gröger), CSIRO (Dr. Paul Cleary).

### FUNDED

STW, Industry	
University	-
FOM	-
STW	75%
NWO Other	-
Industry	25%
TNO	-
GTI	-
EU	-
Scholarships	-

### START OF THE PROJECT

2008

### INFORMATION

V Ogarko

v.ogarko@utwente.nl

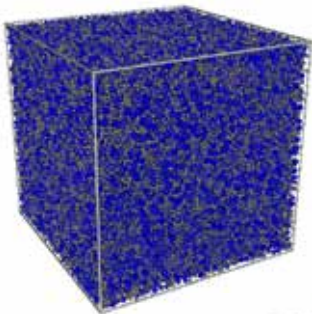

Particle systems with 40% volume fraction, 125001 particles, and a) uniform size distribution, b) uniform volume distribution, i.e., the distribution of the volume of the particles is constant. Colour is by relative size.

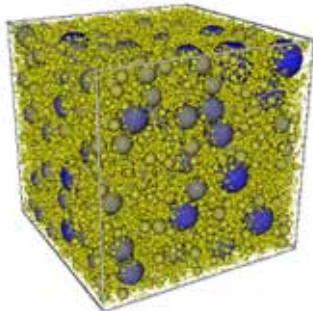

### PROJECT LEADERS

S Luding

### RESEARCH THEME

Complex structures of fluids

### PARTICIPANTS

V Magnanimo, D Krijgsman, N Kumar

### COOPERATIONS

-

### FUNDED

-

University	100%
FOM	-
STW	%
NWO Other	-
Industry	-
TNO	-
GTI	-
EU	-
Scholarships	-

### START OF THE PROJECT

2010

### INFORMATION

V Magnanimo  
053 489 5363  
v.magnanimo@utwente.nl  
www.utwente.nl/ctw/msm/

### PROJECT AIM

Dense granular materials behave differently from fluids or solids. Classical continuum theories fail in describing granular matter and its properties (as dilatancy, yield limit, anisotropy and ratcheting) when the onset of flowing is approached. In fact, the behavior at macro-scale is strongly related to smaller-scale field variables and kinetic processes. Our goal is to solve this lack with a multiscale approach, coupling discrete and continuum. Getting insights from Discrete Element Method (DEM) simulations a continuum in-homogeneous model will be developed and implemented to describe the macroscopic behavior of the material in terms of homogeneous local properties.

### PROGRESS

In this first year, a local constitutive model with anisotropy has been developed and applied to 2D (homogeneous) axial-symmetric deformation. The simplified model involves only scalar quantities and a new ingredient, the anisotropy. As opposed to isotropic materials, shear strain can cause e.g. dilation and hence compressive stresses, when anisotropy is considered. The shear stress ratio and the anisotropy evolve non-linearly to their critical-state limit when shear deformations increase and the flowing failure is approached. The local field variables are expressed in terms of material parameters, measured by DEM simulations, leading to a complete calibration of the predictive model. When applied to cyclic isobaric deformation, the model was capable of showing ratcheting, leading to an increase (decrease) of volume in each cycle. The step now in progress is the formulation of the model for arbitrary orientations of the stress-, strain- and anisotropy-tensors.

### DISSERTATIONS

-

### SCIENTIFIC PUBLICATIONS

1. S. Luding and S. Perdahcioglu, "A local constitutive model with anisotropy for various homogeneous 2d biaxial deformation modes". CIT, accepted for publication (2010).
2. V. Magnanimo and S. Luding, "A local constitutive model with anisotropy for ratcheting under 2D axial-symmetric isobaric deformation", Granular Matter, accepted for publication (2010).
3. L. La Ragione and V. Magnanimo, "Inherent anisotropy and coordination number for a granular assembly in a laboratory test", submitted to Mechanics of Materials (2010).
4. V. Magnanimo, L. La Ragione and S. Luding, "A micromechanical numerical analysis for triaxial compression of granular materials", in conference proceedings of Fifth International Conference on Multiscale Materials Modeling, 4-8 October 2010, Friburg (Ed. P. Gumbsch and E. van der Giessen), Fraunhofer Verlag (2010).

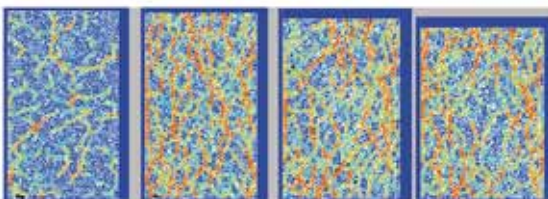

# MODELING OF LONG-RANGE INTERACTION FORCES AND CLUSTERING PHASE DIAGRAM

## PROJECT AIM

The objective of this Ph.D. project is to develop a three dimensional Molecular Dynamics (MD) environment and hydrodynamic theory for modeling long-range interaction forces based on hierarchical algorithms. The aim is both to model attractive/repulsive Coulomb interactions in homogeneous systems and compare the results with theoretical work.

## PROGRESS

In the last year, we focused mainly in the study of a new event-driven algorithm, that permits the simulation of cluster of particles. The method was used to study the formation of fractals with a in a cluster-cluster aggregation process. We also studied the stability analysis of the granular gas in presence of long range interactions: since the collision rate depends explicitly in the temperature, the equations are non-linear. We are currently working on this problem.

## DISSERTATIONS

-

## SCIENTIFIC PUBLICATIONS

1. Consequences of using different pair-correlation functions on the stability properties of the Homogeneous Cooling State for a monodisperse system of near-elastic disks, S. González and S. Luding, Eur. Phys. J. Special Topics 179, 55-68 (2010).
2. An event driven algorithm for fractal cluster formation, S. Gonzalez, A. R. Thornton, and S. Luding, in press, CPC 2010.

## PROJECT LEADERS

S Luding

## RESEARCH THEME

Complex dynamics of fluids

## PARTICIPANTS

S Gonzalez, AR Thornton, S Luding

## COOPERATIONS

T Pöschel, Erlangen (Germany)

## FUNDED

FOM	
University	-
FOM	100%
STW	-
NWO Other	-
Industry	-
TNO	-
GTI	-
EU	-
Scholarships	-

## START OF THE PROJECT

2009

## INFORMATION

S Gonzalez

053 489 3371

j.s.l.gonzalezbriones@utwente.nl

Fractal dimension as a function of packing fraction for systems with 106 particles. The dots are the simulation results while the solid line is just a guide to the eye. In the inset, two examples of the structures obtained for two different densities, dilute and dense. The structures are colored from red to blue depending on the distance to the central particle [2].

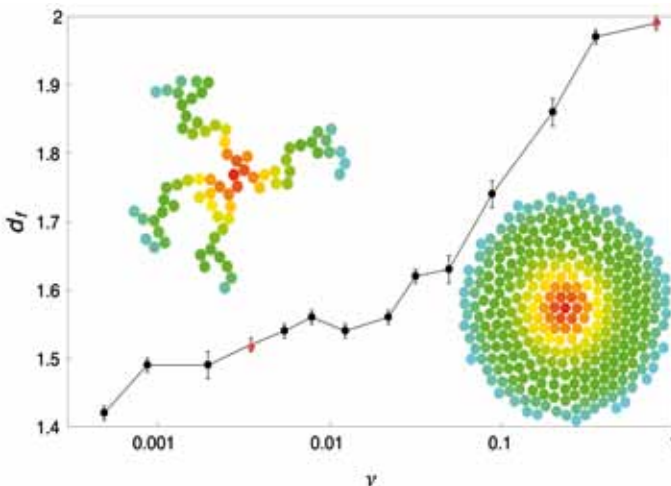



## BRIDGING THE GAP BETWEEN PARTICULATE SYSTEMS AND CONTINUUM THEORY

### PROJECT LEADERS

S Luding, V Magnanimo

### RESEARCH THEME

Complex structures of fluids

### PARTICIPANTS

D Krijgsman

### COOPERATIONS

Prof R.P. Behringer

### FUNDED

NWO

University -

FOM -

STW -

NWO Other 100%

Industry -

TNO -

GTI -

EU -

Scholarships -

### START OF THE PROJECT

2010

### INFORMATION

D Krijgsman

053 494 732

d.krijgsman@utwente.nl

### PROJECT AIM

To bridge the gap between discrete (micro) and continuum (macro) concepts for the modeling and better understanding of particulate systems, using micro-macro transition methods. Modern discrete particle-based models can describe the particles in detail, but are of limited value for studying industrial processes and natural phenomena, since too many particles are involved. Continuum methods on the other hand are successfully applied in engineering. However, they rely on empirical constitutive laws with phenomenological parameters that disregard the discrete nature of particles and micro-structures. Micro-macro transition methods combine advantages of discrete and continuum models.

### PROGRESS

A novel local constitutive model based on observations from Discrete Element simulations has been developed for the small scale deformation of a quasi steady bi-axial geometry. The model consists of a nonlinear evolution equation for both shear stress and anisotropy during deviatoric (shear) deformation, to model the history dependence, while only involving only four material parameters. Several simulations are performed to test the accuracy for different deformation modes (see for example the Figure). Future work includes, extending the model to the general three dimensional cases and implementing it in a FEM method. With this method the stresses and strains on macro scale applications can be predicted by taking the evolution of the material structure into account.

### DISSERTATIONS

-

### SCIENTIFIC PUBLICATIONS

1. S. Luding and S. Perdahcioglu, A local constitutive model with anisotropy for various homogeneous 2D bi-axial deformation modes, CIT, submitted (2010), re-submitted (27.01.2011).
2. V. Magnanimo and S. Luding, A local constitutive model with anisotropy -- ratcheting under 2D bi-axial isobaric deformation, Granular Matter, submitted (2010).

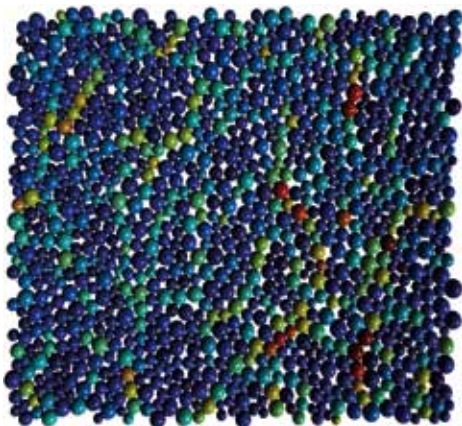

Snapshot of a 2D shear deformation experiment. Particles are colored by potential energy. Some particles have a much higher potential energy (and thus contribution to the stress field) than their neighboring Particles. These groups of particles are called stress chains and are frequently observed in granular materials.

# PREDICTIVE MODELS FOR ELEMENT TESTS: TOWARDS COHESIVE POWDERS IN THE FIELD OF DISCRETE ELEMENT METHODS (DEM)

## PROJECT AIM

This project focuses on parameter identification for DEM and (using these parameters) the goal is predictive DEM simulation of selected element tests of powders. New and more realistic models for cohesive powders are to be identified, implemented and tested against experiments. After quantitative agreement is established with experiments, the challenge is to provide a predictive tool that can not only reproduce, but also foresee the powder behavior in various different situations. Only when this is established, the way to various applications in powder transport or processing is open. The predictive power of such models will be finally ascertained also for larger scale systems.

## PROGRESS

Literature review on the contact models and algorithm search was done. Particular experiments were implemented and executed. The same system was also implemented in the numerical simulations. Comparison of results from the experiments and simulation are in progress. Summer schools in Vienna, Ludwigshafen were attended for enhancing our knowledge. The research plan for the next six months was presented to the PARDEM consortium. System for bulk simulation for different contact models: Free flow of grains is observed with experiments and simulations. Contacts models implemented:

- non-linear visco-elastic (Kuwabara-Kono contact model)
- elasto-plastic model, this is not called the Thornton-Tomas model

Parameters of structure of system:

- Hourglass with double opened holes between boxes
- Size of each box : 50mm x 50mm x 70mm
- 10,000 grains and size of holes: 12mm, 14mm, 16mm

Parameters observed (expectation): time of flow (wet grain should flow longer), porosity (dry grains should have more packed structure due to higher oscillations), differences in force acting on the bottom of the box.

## DISSERTATIONS

-

## SCIENTIFIC PUBLICATIONS

1. "Rapeseed impact against a flat surface: Physical testing and DEM simulation with two contact models", Wojtkowski M., Horabik J., Molenda M., Pecen J., Powder Technology Volume 198, Issue 1, 20 February 2010, Pages 61-68.

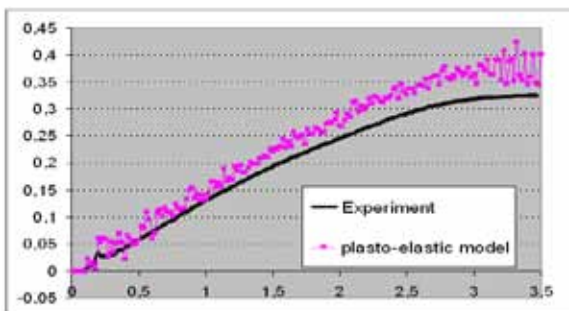

Force acting on bottom in function of time for plasto-elastic contact model (black line is from experiment)

## PROJECT LEADERS

S Luding

## RESEARCH THEME

Complex dynamics of fluids

## PARTICIPANTS

M Wojtkowski, O Imole

## COOPERATIONS

NESTLE, Switzerland, NASA

## FUNDED

EU

University -

FOM -

STW -

NWO Other -

Industry -

TNO -

GTI -

EU 100%

Scholarships -

## START OF THE PROJECT

2010

## INFORMATION

M Wojtkowski

WojtkowskiMB@utwente.nl

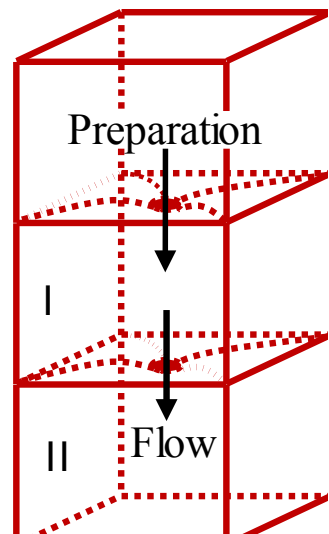

# H-MSM HIERARCHICAL MULTI-SCALE MODELING: A SINGLE DATA STRUCTURE FOR MICRO-MACRO AND MULTI PHASE/FIELD MODELS

## PROJECT LEADERS

S Luding

## RESEARCH THEME

Mathematical and computational methods for fluid flow analysis

## PARTICIPANTS

K Yazdchi, V Ogarko, S Srivastava

## COOPERATIONS

IMPACT, DEM Solutions, CSIRO

## FUNDED

STW

University -

FOM -

STW 75%

NWO Other -

Industry 25%

TNO -

GTI -

EU -

Scholarships -

## START OF THE PROJECT

2008

## INFORMATION

K Yazdchi

053 489 3345,

k.yazdchi@utwente.nl

www2.msm.ctw.utwente.nl/kyazdchi/

index.html

## PROJECT AIM

The goal of this project is to develop a multi-scale computational method that uses a single hierarchical data-structure as basis – involving also multiple fields. Starting from meso-scopic structures (particles or domains) a grid is constructed on a hierarchical data structure. Algorithms and methods from various disciplines like computational fluid dynamics (CFD), molecular dynamics (MD), finite element method (FEM), etc., have to be combined. The scientific challenge is to understand systems with strongly different particle sizes with gas-, fluid-, and solid-like behavior at the same time. This involves multi-physics, micro-systems, (moving) interfaces and multi-field problems in general. More specific, such systems occur in grinding or comminution and transport of particulate systems – before and during processing of modern, high-performance materials.

## PROGRESS

The basic properties of Delaunay Triangulation (DT) data structures are reviewed. The major advantage of Delaunay edges/triangles/tetrahedra is that, they can be used not only for contact detection but also for our FEM/CFD coupling as a mesh and for the micro-macro transition. In the next stage, An analytical-numerical approach is developed for computing the macroscopic permeability of (dis)ordered fibrous porous media taking into account their micro-structure. In particular, the effects of particle shape, orientation and volume fraction, on the overall permeability are studied in detail. The representation proposed is compared with the well known Carman-Kozeny (CK) equation. At this moment, we are studying the correlations between macroscopic properties, like permeability, and Delaunay edge statistics in random fibrous media. The results from this study can be used for verification and validation, i.e., as a closure relation, of more advanced coarse-grained models for particle-fluid interaction and for the coupling of DEM with FEM for moving particles.

## DISSERTATIONS

-

## SCIENTIFIC PUBLICATIONS

1. K. Yazdchi, S. Srivastava and S. Luding, On the transition from creeping to inertial flow in arrays of cylinders, Proceedings of IMECE, 6 pages, Vancouver, British Columbia, 2010, ISBN-978-0-7918-3891-4.
2. K. Yazdchi, M. Salehi, On Viscoelasticity in CNT-Reinforced Polymer Composites, Proceedings of IMECE, 6 pages, Vancouver, British Columbia, 2010, ISBN-978-0-7918-3891-4.
3. K. Yazdchi, S. Srivastava and S. Luding, Multi-Scale permeability of particulate and porous media, World Congress Particle Technology 6, Nuremberg, CD-Proceedings, 4 pages, Nürnberg Messe GmbH (Ed.), March 2010, ISBN-978-3-00-030570-2.
4. V. Ogarko, S. Luding, Data structures and algorithms for contact detection in numerical simulation of discrete particle systems, World Congress Particle Technology 6, Nuremberg, CD-Proceedings, 4 pages, Nürnberg Messe GmbH (Ed.), March 2010, ISBN-978-3-00-030570-2.





Prof.dr. SJMH Hulscher

The work of the “Water Engineering and Management (WEM) group was originally mainly devoted to the modelling of sand waves on the seabed. First it was shown, that the seabed patterns in the North Sea can be explained as free instabilities of the seabed. Subsequently, the modelling of sand waves was extended and refined. The group has worked on a scientific and practical tool for fully nonlinear modelling of sand waves. Over the last five years, the offshore morphodynamic work has broadened to rivers, coasts and blue-ice. Alternate bars in a flume were compared with (Ginzburg-)Landau-type models. The group was the first to explore data assimilation for morphodynamic predictions. Further work concentrated on using data assimilation to combine field data with sand wave amplitude models for maintenance dredging management of navigation channels and sand wave-related pipeline problems. Also, North Sea data were analysed and a new bed mode, called long bedwaves, was discovered. The origin of nearshore bars was addressed. A method was developed for modelling human interferences in a morphodynamic setting. This has opened perspectives for a new approach towards modelling large-scale sand mining in shallow seas. A project for developing tools for evaluation of human interference in the North Sea for optimal management of the seabed started recently and sediment transport concerning near-shore sand pits is being investigated. Since 2000 the group has studied the use of morphodynamical models in a societal context. Recently, a method for decision making based on quantitative information including uncertainties was developed in the multidisciplinary project Flyland, which opens the field of designing an assessment framework for appropriate modelling.

### PROJECT AIM

On the bed of the North Sea sand waves are present, which grow up to 25% of the water depth and migrate at a speed of tens of meters per year. These sand waves can pose a hazard to offshore constructions, navigation, pipelines and telecommunication cables. On the other hand, bed forms can protect the coastline against storms. The bottom of the North Sea is also covered by a great number of organisms live in and on the bottom of the sea. These organisms try to optimize their habitat, resulting in bio-geomorphological interactions. The precise interaction between the biological activity and geomorphodynamics is not known at this moment. Such knowledge is of great interest for reliable long-term geomorphodynamic predictions, especially in marine environments with large biological activities.

### PROGRESS

Model and flume experiments are executed in which the biogeomorphological interactions are further analysed.

### DISSERTATIONS

-

### SCIENTIFIC PUBLICATIONS

1. Borsje, B.W., van Wesenbeeck, B., Dekker, F., Paalvast, P., Bouma, T.J., de Vries, M.B., 2010. How ecological engineering can serve in coastal protection. *Ecological Engineering*, accepted. doi: 10.1016/j.ecoleng.2010.11.027.
2. Borsje, B.W., van der Werf, J.J., Kruijt, M.A., Hulscher, S.J.M.H., Herman, P.M.J., 2010. Modeling biogeomorphological interactions in underwater nourishments for the Dutch sandy coast. *Proceedings of the 32nd International Conference on Coastal Engineering (ICCE)*, Shanghai, China.
3. Borsje, B.W., van Wesenbeeck, B., Dekker, F., Paalvast, P., Bouma, T.J., van Katwijk, M.M., de Vries, M.B., 2010. How ecological engineering can serve in coastal defence strategies. In: (Eds). *Proceedings of the NCK-days 2010*, Zeeland, The Netherlands, pp. 30.

### PROJECT LEADERS

SJMH Hulscher

### RESEARCH THEME

Mathematical and computational methods for fluid flow analysis

### PARTICIPANTS

BW Borsje, PMJ Herman, SJMH Hulscher, MB de Vries

### COOPERATIONS

Deltares

### FUNDED

STW	
University	100%
FOM	-
STW	-
NWO Other	-
Industry	-
TNO	-
GTI	-
EU	-
Scholarships	-

### START OF THE PROJECT

2007

### INFORMATION

BW Borsje  
053 489 4038  
b.w.borsje@utwente.nl



**PROJECT LEADERS**

SJMH Hulscher, CM Dohmen-Janssen

**RESEARCH THEME**

Complex dynamics of fluids

**PARTICIPANTS**

EM Horstman, CM Dohmen-Janssen, SJMH Hulscher, PMJ Herman, TJ Bouma, EL Webb, DA Friess, C Sudtongkong, D Galli, T Balke

**COOPERATIONS**

Singapore-Delft Water Alliance, Deltares, National University of Singapore, Public Utilities Board Singapore, Rajamangala University of Technology Srivijaya, Chulalongkorn University

**FUNDED**

Singapore-Delft Water Alliance	
University	25%
FOM	-
STW	-
NWO Other	-
Industry	75%
TNO	-
GTI	-
EU	-
Scholarships	-

**START OF THE PROJECT**

2009

**INFORMATION**

E Horstman  
053 489 35 46  
E.M.Horstman@utwente.nl  
www.utwente.nl/ctw/wem/organisatie/  
medewerkers/horstman.doc

**PROJECT AIM**

Quantify the bio-physical interactions that control the dissipation of hydrodynamic energy and sediment transport and deposition in coastal mangroves. Develop a process-based hydrodynamic and morphodynamic model to describe the attenuation of hydrodynamic energy by bio-physical interactions within coastal mangroves and the effects on the local morphology. Determine the potential use of coastal mangroves to attenuate hydrodynamic energy and the effect on the local morphology, using this process-based model.

**PROGRESS**

The past year has been spent on planning and preparing for the fieldwork campaign. Hydrodynamic equipment (ADV, ADCP, HR ADCP) and sediment trapping techniques have been compared to select the equipment/methods best suitable for our field studies. Field sites have been visited in Singapore, Malaysia and Thailand and research permits have been requested for in these three countries. An extensive fieldwork campaign of 5 months is now taking place in two mangrove estuaries at the Andaman coast of Southern Thailand. Wave heights, current velocities, suspended sediment concentrations, sediment deposition, bottom elevation and vegetation density are being monitored along two contrasting transects through the mangroves (6 points, up to 300 m) and in a mangrove creek catchment (16 points, 100x100 m<sup>2</sup>).

**DISSERTATIONS**

-

**SCIENTIFIC PUBLICATIONS**

1. Horstman, E.M., Dohmen-Janssen, C.M., Balke, T., Bouma, T.J., Friess, D.A., Galli, D., Webb, E.L., Herman, P.M.J. & Hulscher, S.J.M.H. (2010). Measuring short-term biophysical interactions in coastal mangroves in matang, Malaysia. In Book of abstracts NCK-Days 2010, 25-26 March 2010, Westkapelle, The Netherlands (pp. 41-41). Delft: NCK.
2. Horstman, E.M., Balke, T., Dohmen-Janssen, C.M., Bouma, T.J., Herman, P.M.J. & Hulscher, S.J.M.H. (2010). The best way of measuring flow patterns on tidal marshes. In 32nd International Conference on Coastal Engineering, June 30 - July 5, 2010, Shanghai, China (pp. 404). Shanghai: ICCE 2010 local organizing committee.



## PROCESS-BASED MODELING OF SEDIMENT TRANSPORT UNDER WAVES IN THE SHEET-FLOW REGIME

### PROJECT AIM

The main objective of this project is the development of a validated process-based numerical model for sand transport under progressive surface wave in the sheet-flow regime. A second objective is to gain insight in the effects and relative importance of various processes on sediment transport by application of the model on cases with various hydrodynamic and morphological conditions. To enable implementation of results from phase 1&2 into morpho-dynamic models on engineering scale, the third objective is to develop a parameterization of the model results.

### PROGRESS

The main progress of last year (2010) was the inclusion of free surface effects in a 1DV RANS boundary layer model with  $k-\epsilon$  turbulence closure. The model has been validated quite extensively on experimental data of the flow in the wave boundary layer. A remarkable free surface effect is the generation of 'real wave streaming', an additional onshore directed wave-averaged boundary layer current. The model has been used to quantify the relevance of this mechanism for current and bed shear stress. Furthermore, the influence of this process on sediment transport has been investigated. It was shown that the streaming indeed contributes significantly to onshore sediment transport, but that it can not be the only explanation for the different transport rates found in wave flumes (with a free surface) and oscillating flow tunnels (without a free surface).

### DISSERTATIONS

-

### SCIENTIFIC PUBLICATIONS

1. Wouter Kranenburg, Jan Ribberink, Rob Uittenbogaard; 'Sand transport by surface waves: numerical reproduction of recent experiments', Book of Abstracts, 32th ICCE, June 30- July 5, 2010, Shanghai, China.
2. Wouter Kranenburg, Jan Ribberink and Rob Uittenbogaard; 'Sand transport by surface waves: can streaming explain the onshore transport?', Proceedings of 32th ICCE, Shanghai, China, 2010.
3. Wouter Kranenburg, Jan Ribberink, Rob Uittenbogaard; 'Net currents in the wave boundary layer: balance of wave shape and free surface effects', Proceedings Coastal Sediments 2011, accepted.

### PROJECT LEADERS

SJMH Hulscher

### RESEARCH THEME

Complex dynamics of fluids

### PARTICIPANTS

WM Kranenburg, JS Ribberink, RE Uittenbogaard, SJMH Hulscher

### COOPERATIONS

Closely linked to: SANTOSS (Sand Transport in Oscillatory flow in the Sheet-flow regime) and Hydralab IV-WISE

### FUNDED

Hydralab III-SANDS (EU-project)

Hydralab IV-WISE (EU-project)

University of Twente

University -

FOM -

STW -

NWO Other -

Industry 50%

TNO -

GTI -

EU 50%

Scholarships -

### START OF THE PROJECT

2008

### INFORMATION

WM Kranenburg

053 489 2959

w.m.kranenburg@utwente.nl

www.wem.ctw.utwente.nl



#### PROJECT LEADERS

SJM Hulscher, CM Dohmen-Janssen

#### RESEARCH THEME

Mathematical and computational methods for fluid flow analysis

#### PARTICIPANTS

OJM van Duin, S Naqshband,  
FM Sterlini-van der Meer,  
JS Ribberink, R Schielen,  
AJ Paalberg

#### COOPERATIONS

Deltares, HKV, Rijkswaterstaat,  
Waterdienst, University of  
Braunschweig

#### FUNDED

NWO/STW, University of Twente,  
Deltares/RWS, HKV  
University 45%  
FOM -  
STW -  
NWO Other 50%  
Industry 5%  
TNO -  
GTI -  
EU -  
Scholarships -

#### START OF THE PROJECT

2010

#### INFORMATION

OJM van Duin  
O.J.M.vanDuin@utwente.nl

S Naqshband  
S.Naqshband@utwente.nl

#### PROJECT AIM

Subproject 1: Dune evolution and transition to plane beds (van Duin)

The overall objective of this subproject is to model and better understand (1) the (processes leading to) the transition to upper-stage plane beds, (2) the evolution and occurrence of specific dune morphologies (e.g. superimposed dunes, low-angle dunes) and (3) the roughness associated with the aforementioned bed configurations.

Subproject 2: The influence of suspended sediment transport on dune evolution (Naqshband) The overall objective of this subproject is to model and better understand the effects of suspended load on (1) dune morphology, (2) dune evolution and (3) transition from dunes to upper stage plane beds.

#### PROGRESS

This research project started with a literature study on dunes and sediment transport, and an exploration of the dune evolution model developed by Paarlberg et al. [2009]. The second part of the first year research has been filled with writing research proposal and defending it successfully in a formal meeting, in front of the Disciplinary council of Civil Engineering. Furthermore, several planned courses are completed in the first year of research e.g. course on Turbulence, Technical editing and writing, and Programming in Engineering. In addition, a first step has been taken to extend the dune evolution model by incorporating suspended sediment transport. To realize transition of dunes to upper stage plane beds, the bed load transport equation used in the current model will be adjusted as well. Finally, laboratory experiments are planned to be carried out this year (summer) to give us insight in the behaviour of dunes and upper stage plane beds.

#### DISSERTATIONS

-

#### SCIENTIFIC PUBLICATIONS

1. Naqshband, S., Sterlini-van der Meer, F. M., Dohmen-Janssen, C.M. & Hulscher, S.J.M.H. (2010). On the influence of suspended sediment transport on dune evolution. In E. Stouthamer (Ed.), NCR-days 2010. Book of Abstracts, abstract no. 21 (pp.1). Delft: NCR.
2. Duin, O.J.M. van, Ribberink, J.S., Dohmen-Janssen, C.M., Hulscher, S.J.M.H. (2010). River dune evolution and the transition to plane beds. In E. Stouthamer (Ed.), NCR-days 2010. Book of abstracts (pp. 1-2). Delft: NCR.

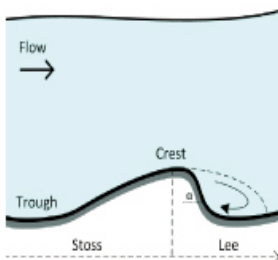

## ANALYSIS OF CHANGE IN THE MARINE ENVIRONMENT. SUPPORT FOR ENVIRONMENTAL MONITORING PROCEDURES

### PROJECT AIM

In recent years, offshore wind power has emerged as a promising renewable energy resource. However, if we want to guarantee that these developments are also ecologically sustainable it is important to assess the impact of offshore windfarms on marine fauna. This work addresses the research effort made in the field of spatio-temporal data analysis methods to investigate the ability to assess impact, knowing that issues such as species behavior and survey characteristics play a role. Specifically, the focus is on the effects that wind farms may have on the displacement of birds from the construction area.

### PROGRESS

We have extended the previously developed impact assessment method to be suited for statistical power analysis. In this manner, the amount of influence that species behavior and survey characteristics have on the ability to detect impact can be analyzed. Our results showed that the environmental conditions at the time of the survey is the most influential factor on power. This is followed by survey effort and species abundance in the reference situation. Spatial dependence in species numbers at local scales affects power, but its effect is smaller for the scenarios investigated. Moreover, we have investigated the effect of patterns in seabird abundance that are not understood or can not be deterministically modelled on the ability to detect impact. This showed that overestimation and underestimation of power occurs, depending on the temporal changes in the spatial pattern of environmental conditions between pre- and post-construction periods of an offshore wind farm.

### DISSERTATIONS

-

### SCIENTIFIC PUBLICATIONS

1. B. Pérez Lapeña, K. Wijnberg, S. J. M. H. Hulscher, A. Stein (2010). Environmental impact assessment of offshore wind farms: a simulation-based approach. *Journal of Applied Ecology*, 47: 1110–1118.

### PROJECT LEADERS

SJM Hulscher, KM Wijnberg

### RESEARCH THEME

Complex dynamics of fluids

### PARTICIPANTS

Blanca Pérez Lapeña (researcher), Prof. dr. Suzanne Hulscher (promotor), Dr. Kathelijne Wijnberg (daily supervisor). Dr. Jan de Leeuw (external supervisor as to 31-01-09) Prof. dr. Ir. Alfred Stein (promotor as of 01-02-09)

### COOPERATIONS

RWS, IMARES, NoordzeeWind

### FUNDED

UT/BSIK	
University	50%
FOM	-
STW	-
NWO Other	-
Industry	50%
TNO	-
GTI	-
EU	-
Scholarships	-

### START OF THE PROJECT

2006

### INFORMATION

B Perez Lapeña.

053 489 4446

b.perez-lapena@ctw.utwente.nl

wem.ctw.utwente.nl

**PROJECT LEADERS**

PC Roos

**RESEARCH THEME**

Complex dynamics of fluids

**PARTICIPANTS**

PC Roos

**COOPERATIONS**

Advanced Consultancy Romke Bijker, Deltares, Rijkswaterstaat Directie Noordzee, Netherlands Hydrographic Service, Saxion Hogescholen, Witteveen+Bos

**FUNDED**

NWO-STW (VENI grant)  
University 33%  
FOM -  
STW 66%  
NWO Other -  
Industry -  
TNO -  
GTI -  
EU -  
Scholarships -

**START OF THE PROJECT**

2006 (ended May 2010)

**INFORMATION**

PC Roos  
053 489 5608  
p.c.roos@utwente.nl

**PROJECT AIM**

The aim of this VENI project is to develop hydrodynamic and morphodynamic modelling tools that provide insight in large-scale seabed patterns and their response to sea level rise and sand extraction. A further goal is to bridge a methodological gap in the field of morphodynamic modeling by developing idealized models in interaction with engineering modelers.

**PROGRESS**

The final part of the project focused on the impact of mega-scale sand extraction from the North Sea on tidal dynamics. An idealized study was conducted to gain insight in the impact of a trench (about 200 km long, 10 km wide and several m deep), located in front of the Dutch coast. As closure of the project, a workshop was organized on 27 april 2010 where the results from this idealized model study were compared to those using a typical engineering study. The workshop was attended by scientists, engineers from dredging and consultancy firms as well as coastal managers.

**DISSERTATIONS**

-

**SCIENTIFIC PUBLICATIONS**

1. Roos, P.C. & J.J. van der Werf (2010) Mega-scale sand extraction from the North Sea, Hydro Int. 14(6), 14-17.
2. Idier, D., S. Hommes, C. Briere, P.C. Roos, D.-J.R. Walstra, M.A.F. Knaapen & S.J.M.H. Hulscher (2010). Morphodynamic Models Used to Study the Impact of Offshore Aggregate Extraction: a Review. J. Coast. Res. 51, 39-52. doi: 10.2112/SI51-004.1.
3. Brière, C., P.C. Roos, E. Garel & S.J.M.H. Hulscher (2010). Modelling the Morphodynamics of the Kwinte Bank, Subject to Sand Extraction. J. Coast. Res. 51, 117-126. doi: 10.2112/SI51-011.1.

Impact of mega-scale sand extraction trench on tidal dynamics. (a) Amphidromic system without trench, (b) with trench (tidal range in m). Finally, (c) shows the differences in tidal range due to the trench.

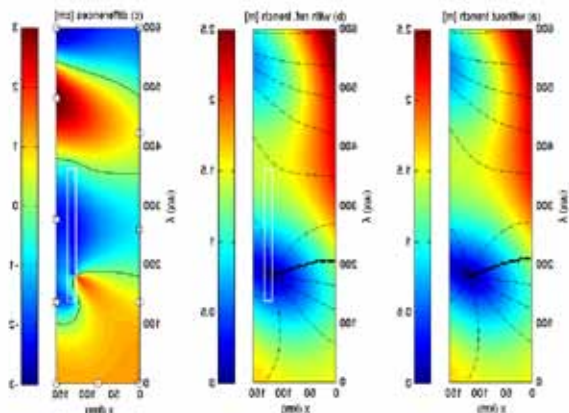





Prof.dr.ir. HB Levinsky

The mission of the Combustion Science and Engineering program is to:

- ♦ provide insight into the fundamental physical and chemical processes responsible for the behavior of high-temperature reacting systems, such as flames and low-temperature plasmas,
- ♦ conceive ways to control this behavior based on the insight gained,
- ♦ “translate” the results obtained into terms useful for engineering practice,
- ♦ disseminate the knowledge generated to both the scientific and practical communities,
- ♦ analyze the technical consequences of energy policy choices.

Combustion can be defined as a self-sustaining transition of a system from a non-equilibrium state, e.g., unreacted fuel and oxidizer, to equilibrium, accompanied by energy release. The combustion of even the simplest fossil fuel, methane, is exceptionally complex. Hundreds of elementary reactions involving many tens of chemical species are intimately coupled to energy and mass transport, yielding a spatial structure: the flame. The coupling of chemical reaction to transport renders the details of flame structure sensitive to external factors, and changes in fluid flow, heat transfer and identity of the fuel have major impacts on combustion properties (ignition, flame extinction, pollutant formation). The emphasis of the program is to formulate a microscopically correct and theoretically coherent description of the energy conversion process.

Since the only reliable source of information on this process is experiment, we develop and use non-invasive laser-spectroscopic methods (such as laser-induced fluorescence, spontaneous and coherent anti-stokes Raman scattering) to analyze stationary and instationary high-temperature reacting systems. Deeper insight is gained into system behavior by performing theoretical analyses of the phenomena under study, including the use of advanced numerical codes that solve the full conservation equations (i.e., including detailed transport and chemistry).

#### CURRENT ACTIVITIES

The majority of the current projects concern the effects of hydrogen addition on fossil fuel combustion. The results of these studies are used to point out the technical consequences of the future integration of hydrogen into the energy supply. Particularly, the limitations posed by the combustion behavior of hydrogen in existing equipment will have a major impact on any transition to a hydrogen economy.

- ♦ Flame structure: In two projects, laser diagnostics are developed and applied in flames at low pressure (to enlarge the size of the primary reaction zone) to study key intermediates responsible for pollutant formation, particularly NO<sub>x</sub> and soot. Analysis of the experimental results and comparison with those from numerical models help identify the shortcomings in the models, such as potentially incorrect boundary conditions, uncertainties in transport phenomena and failures in chemical mechanisms. Also, the possible effects of hydrogen addition to natural gas and other alkanes (suggested in energy policy for the transition to sustainable energy) on oxidation mechanism and pollutant formation are examined. Further, in a third project, the flame structure of pure hydrogen flames and hydrogen/alkane flames at atmospheric pressure are being studied. Here, the peculiar transport properties of hydrogen are particularly manifested.

- ♦ Ignition phenomena: A RCM is being built for a dual purpose: to assess the effects of sustainable fuels (hydrogen and biogas) on alkane ignition (related to engine knock) and to serve as an instrument with which, in combination with laser diagnostics currently being developed, elementary chemical processes in ignition are to be studied.
- ♦ Laser diagnostics: Raman, IR-absorption and laser-fluorescence methods are being developed for quantitative analysis of high-temperature reacting systems.

**PROJECT LEADERS**

HB Levinsky, AV Mokhov

**RESEARCH THEME**

Complex structures of fluids

**PARTICIPANTS**

AV Sepman

**COOPERATIONS**

TU/e, Tata, Numeca

**FUNDED**

STW, Tata, Numeca

University -

FOM -

STW -

NWO Other 70%

Industry 30%

TNO -

GTI -

EU -

Scholarships -

**START OF THE PROJECT**

2009

**INFORMATION**

HB Levinsky (KEMA)

050 7009739

www.flame.fmns.rug.nl

**PROJECT AIM**

Combustion using highly preheated air, together with diluted air and/or fuel, is a clean combustion concept that combines high efficiency and low pollutant emissions in industrial heating processes. To permit the optimization of NO<sub>x</sub> control, and to provide insight into the ultimate low-NO<sub>x</sub> potential of these methods, in this research we investigate the paths to NO formation in dilute, high temperature combustion. Towards this end, we perform quantitative laser-diagnostic measurements of flame structure, using LIF, Raman and TDLAS methods in the laminar coflow geometry, combined with detailed numerical simulations of the structure of the reaction zone.

**PROGRESS**

A study of the use of different molecules to determine the gas temperature in the range 300-2200 K by Raman scattering was performed. The results show that N<sub>2</sub>, CO, CO<sub>2</sub>, H<sub>2</sub>O and O<sub>2</sub> generally give temperatures that agree to within 50 K, and in the worst case (at the highest temperatures) within 100 K. Using modern laser (30 W power) and detection (new sensitive cameras) technology excellent reproducibility over the entire range of temperature can be obtained. Measurements of NO (LIF) and HCN (TDLAS) in fuel-rich-premixed methane, ethane and propane flames with and without added hydrogen show only a modest effect of hydrogen addition on the Fenimore mechanism of NO formation in these fuels. Comparisons of simulations of the flame systems with the measurements shows that new mechanisms of NO formation, and particularly regarding the oxidation of NCN, can reproduce the experimental results reasonably.

**DISSERTATIONS**

-

**SCIENTIFIC PUBLICATIONS**

-







Prof.dr. AEP Veldman

The group Computational Mechanics and Numerical MathemThe group Computational Mechanics and Numerical Mathematics at the University of Groningen focuses on the development of numerical solution methods for partial differential equations in general, and for (aero- and hydrodynamic) flow simulation in particular (CFD). Keywords for our algorithmic developments are symmetry-preserving discretization, Cartesian cut-cell approach, sharp-interface methods, efficient sparse-matrix solvers and large-scale continuation methods. It is our strategy to combine all algorithmic innovations from the individual research projects into one coherent CFD concept, such that all projects can profit from each other.

Application areas are direct and large-eddy simulation of turbulent flow, free-surface flow in aerospace (sloshing onboard spacecraft) and maritime engineering (hydrodynamic wave loading), oceanography (stability of the global ocean circulation), bio-medical fluid dynamics (hemodynamics) and heat transport (Rayleigh-Bénard flow). We plan to extend our thus far mainly mono-disciplinary flow problems towards multi-physics: fluid-structure interaction, two-phase flow, atmospheric flow and turbulent combustion. In the process of knowledge transfer, the in-house developed computer codes ComFlo and MRILU play an important role. atics at the University of Groningen focuses on the development of numerical solution methods for partial differential equations in general, and for (aero- and hydrodynamic) flow simulation in particular (CFD). Keywords for our algorithmic developments are symmetry-preserving discretization, Cartesian cut-cell approach, sharp-interface methods, efficient sparse-matrix solvers and large-scale continuation methods. It is our strategy to combine all algorithmic innovations from the individual research projects into one coherent CFD concept, such that all projects can profit from each other.

Application areas are direct and large-eddy simulation of turbulent flow, free-surface flow in aerospace (sloshing onboard spacecraft) and maritime engineering (hydrodynamic wave loading), oceanography (stability of the global ocean circulation), bio-medical fluid dynamics (hemodynamics) and heat transport (Rayleigh-Bénard flow). We plan to extend our thus far mainly mono-disciplinary flow problems towards multi-physics: fluid-structure interaction, two-phase flow, atmospheric flow and turbulent combustion. In the process of knowledge transfer, the in-house developed computer codes ComFlo and MRILU play an important role.

Snapshot of a simulated turbulent flow at  $Re=3900$

**PROJECT AIM**

A main area of research concerns turbulent flow simulation. Turbulence modeling keeps computational effort within reasonable limits, but a price is paid in terms of accuracy. Thus research into direct numerical simulation (DNS) methods that resolve all length and time scales is envisaged. Our group concentrates on improving numerical techniques (space discretization and time integration) with which the price of DNS can be reduced significantly. Additionally, steps towards mathematical-based LES modeling are made.

**PROGRESS**

The central theme of the project is to model and simulate turbulence in such a way that the symmetry and conservation properties of the Navier-Stokes equations are preserved. In cooperation with MARIN a PhD-project was started which aims to extend the symmetry-preserving discretization method to unstructured grids at high Reynolds numbers. Also with MARIN discretization on curvilinear grids was studied. The joint work with UPC (Barcelona) on symmetry-preserving regularization models for turbulence is continued. In particular, spatial filters for unstructured meshes have been considered. In cooperation with NLR a PhD-project was started in which a detailed numerical simulation method for turbulent flow over aircraft wings will be developed. A new dynamic eddy viscosity model was developed together with the Center for Turbulence Research at Stanford University.

**DISSERTATIONS**

-

**SCIENTIFIC PUBLICATIONS**

1. F.X. Trias, R.W.C.P. Verstappen, A. Gorobets, M. Soria, A. Oliva, Parameter-free symmetry-preserving regularization modeling of a turbulent differentially heated cavity. *Computers and Fluids* 39(10) (2010) 1815-1831.
2. F.X. Trias, R.W.C.P. Verstappen, On the construction of discrete filters for symmetry-preserving regularization models. *Computers and Fluids*, August 2010.
3. J.A. Helder and R.W.C.P. Verstappen, On restraining convective subgrid-scale production in Burgers' equation. *ECCOMAS CFD 2010, Lisbon*, paper 1632.
4. Julian E. Jaramillo, Carlos D. Perez-Segarra, Oriol Lemkuhl and Assensi Oliva, Detailed numerical study of turbulent flows in air curtains. *Proc. ECCOMAS CFD 2010, Lisbon (2010)* paper 1697.
5. F. Xavier Trias, Andrey Gorobets, Roel Verstappen and Assensi Oliva, Regularization modeling of wall-bounded turbulent flows. *Proc. ECCOMAS CFD 2010, Lisbon (2010)* paper 1670.
6. F. Trias, A. Gorobets, A. Oliva, R.C.W.P. Verstappen, Turbulent flow around a square cylinder: direct numerical simulation and regularization modeling. In: H. Kuerten, et al. (eds) *Proceedings DLES8, Eindhoven (2010)*.
7. F.X. Trias, A. Gorobets, A. Oliva and R. Verstappen, Turbulent flow in a differentially heated cavity: direct numerical simulation and regularization modeling. *Proc. 14th Int. Heat Transfer Conf., Washington DC, USA, 2010*.
8. Roel W.C.P. Verstappen, When does eddy viscosity restrict the dynamics to large eddies? *Proc. ECCOMAS CFD 2010, Lisbon (2010)* paper 1302.
9. R. Verstappen and F.X. Trias, Symmetry-preserving regularization models of the Navier-Stokes equations. *ECCOMAS CFD 2010, Lisbon (2010)* paper 1304.

**PROJECT LEADERS**

RWCP Verstappen

**RESEARCH THEME**

Mathematical and computational methods for fluid flow analysis

**PARTICIPANTS**

HJ Bandringa, AJA Kort, JA Helder, W Rozema, M Younas, RWCP Verstappen, AEP Veldman, FW Wubs, J Jaramillo (UPC), FX Trias (UPC), P Moin (Stanford)

**COOPERATIONS**

NLR, MARIN, TUD, UT, Politechnical University of Catalunya (Barcelona, E), Stanford University (USA)

**FUNDED**

Agentschap.nl (EZ), Ubbo Emmius Fonds (RUG), AGAUR (Spain)

University	20%
FOM	-
STW	-
NWO Other	-
Industry	-
TNO	-
GTI	-
EU	-
Scholarships	60%
EZ	20%

**START OF THE PROJECT**

1996

**INFORMATION**

RWCP Verstappen

050 363 3958

R.W.C.P.Verstappen@rug.nl

www.math.rug.nl/~veldman/DNS/

dns-home

10. Roel W.C.P. Verstappen, Regularizations of turbulent flow. In: J.C.F. Pereira and A. Sequeira (eds.) Proc. ECCOMAS CFD 2010, Lisbon (2010) paper 1630.
11. R. Verstappen, An eddy-viscosity model based on the invariants of the rate-of-strain tensor. In: H. Kuerten, et al. (eds) Proceedings DLES8, Eindhoven (2010)
12. Roel Verstappen, When does eddy viscosity damp subfilter scales sufficiently? Proc. 19th Polish Nat. Fluid Dyn. Conf. KKMP 2010, Poznan, Poland, 2010.
13. R.W.C.P. Verstappen, S.T. Bose, J. Lee, H. Choi and P. Moin, A dynamic eddy-viscosity model based on the invariants of the rate-of-strain. Proc. Summer Program 2010, CTR, Stanford University, p. 183-192 (2010).
14. R. Verstappen, S. Bose, J. Lee, H. Choi and P. Moin, A new dynamic eddy viscosity model for LES. Proc. 63rd Ann. Meeting APS Div. Fluid Mech., Nov. 2010, Bull. Amer. Phys. Soc. 55 (2010) p. 265.
15. Roel Verstappen, When does eddy viscosity damp subfilter scales sufficiently? In: M.V. Salvetti et al. (eds), Quality and Reliability of Large-Eddy Simulations II, ERCOFTAC Series 16, Springer Science+Business, p.. 421-430 (2010).

**PROJECT AIM**

A fast-growing application area of our ComFlo simulation method is maritime technology. In close cooperation with MARIN and the offshore industry, focus is on the numerical prediction of hydrodynamic wave loading (green water, slamming) and sloshing in ship tanks.

**PROGRESS**

Early 2010, the ComFLOW-3 project on hydrodynamic wave loading reached full speed by filling the last PhD vacancies. Physical emphasis is on modelling viscous effects during wave impact (e.g. sloshing and side-by-side mooring) and on wave generation and absorption. Numerical efficiency is improved with local grid refinement and parallelization. Main collaborators are TU Delft, MARIN, Deltares and FORCE Technology Norway. Cooperation with Hyundai Heavy Industries (Korea) was intensified by a one-year research visit of dr. Moon (on hydroelasticity).

**DISSERTATIONS**

-

**SCIENTIFIC PUBLICATIONS**

1. T. Bunnik and A.E.P. Veldman, Modelling the effect of sloshing on ship motions. In: Proc. 29th Conf. on Ocean, Offshore and Arctic Eng. OMAE2010, Shanghai, China (2010) paper OMAE-20458, 9 pages.
2. Roel Luppés, Arthur E.P. Veldman and Peter R. Wellens, Absorbing boundary conditions for wave simulations around offshore structures. In: J.C.F. Pereira and A. Sequeira (eds.) Proc. ECCOMAS CFD 2010, Lisbon (2010) CD-ROM paper 1200, 17 pages.

Air entrapment during wave impact in sloshing experiment (MARIN)



**PROJECT LEADERS**

AEP Veldman

**RESEARCH THEME**

Mathematical and computational methods for fluid flow analysis

**PARTICIPANTS**

HJL van der Heiden, R Luppés, P van der Plas, AEP Veldman; B Duz (TUD), RHM Huijsmans (TUD), T Bunnik (MARIN), PR Wellens (Deltares), JS Moon (HHI)

**COOPERATIONS**

TU Delft, MARIN, Deltares, FORCE Technology (Norway), Hyundai Heavy Industries (Korea)

**FUNDED**

STW	
University	-
FOM	-
STW	100%
NWO Other	-
Industry	-
TNO	-
GTI	-
EU	-
Scholarships	-

**START OF THE PROJECT**

1999

**INFORMATION**

AEP Veldman  
 050 363 3988  
 a.e.p.veldman@rug.nl  
 www.math.rug.nl/~veldman/comflow/  
 comflow.html

**PROJECT LEADERS**

FW Wubs

**RESEARCH THEME**

Mathematical and computational methods for fluid flow analysis

**PARTICIPANTS**

H Kirbaş, FW Wubs, RWCP Verstappen, AEP Veldman

**COOPERATIONS**

University of Leuven

**FUNDED**

University	100%
FOM	-
STW	-
NWO Other	-
Industry	-
TNO	-
GTI	-
EU	-
Scholarships	-

**START OF THE PROJECT**

2004

**INFORMATION**

FW Wubs  
050 363 3994  
f.w.wubs@rug.nl  
www.math.rug.nl/~wubs

**PROJECT AIM**

Research focuses on numerical methods to investigate stability and bifurcation behaviour of large-scale problems from our other research applications. Of particular interest are the stability of the global ocean circulation and of coherent structures in turbulent flow.

**PROGRESS**

The project, initiated by dr. Lust who has left the department in 2008, focuses on the computation of self-sustaining coherent structures (unstable periodic solutions) in flow models in the turbulent regime. In this way a link with our turbulent flow research is established. Interfaces were written to connect Fortran codes defining discretizations of the Navier-Stokes code to Trilinos. This allows to use the Trilinos package LOCA for continuation of steady states and periodic solutions.

**DISSERTATIONS**

-

**SCIENTIFIC PUBLICATIONS**

-

**PROJECT AIM**

The repeated solution of large systems of equations in most simulation methods makes the quest for improved matrix solvers another major research area. In-house a multilevel preconditioner (MRILU) and a two level preconditioner for CFD problems (HYMLS) have been developed. Application area is the modelling of flow patterns in global ocean circulation (with UU-IMAU) and the study of the behavior of flows beyond but close to the transition point.

**PROGRESS**

In the research on sparse-matrix solvers the new two-level structure preserving factorization has been implemented in Trilinos and performance tests were done on the Huygens supercomputer for the 3D lid driven cavity. On a 64 cubed grid, till 32 processors good speed-up was attained as long as the solution time of the reduced system is negligible. Further speed-up is expected if the method is transformed to a multilevel method.

**DISSERTATIONS**

-

**SCIENTIFIC PUBLICATIONS**

1. Erik Bernsen, Henk A. Dijkstra, Jonas Thies, Fred W. Wubs, The application of Jacobian-free Newton-Krylov methods to reduce the spin-up time of ocean general circulation models. *J. Comput. Phys.* 229(21) (2010) 8167-8179.
2. J. Thies and F.W. Wubs, A robust parallel ILU solver with grid-independent convergence for the coupled steady incompressible Navier-Stokes equations. In: J.C.F. Pereira and A. Sequeira (eds.) *Proc. ECCOMAS CFD 2010, Lisbon* (2010) CD-ROM paper 1421, 13 pages.

**PROJECTLEADERS**

FW Wubs

**RESEARCHTHEME**

Mathematical and computational methods for fluid flow analysis

**PARTICIPANTS**

J Thies, FW Wubs, HA Dijkstra (UU)

**COOPERATIONS**

IMAU (UU), UL Bruxelles (B), TU Braunschweig (D), RAL (UK), Ege University (Turkey)

**FUNDED**

ALW	
University	-
FOM	-
STW	-
NWO Other	100%
Industry	-
TNO	-
GTI	-
EU	-
Scholarships	-

**START OF THE PROJECT**

1994

**INFORMATION**

FW Wubs  
050 363 3994  
f.w.wubs@rug.nl  
www.math.rug.nl/~wubs

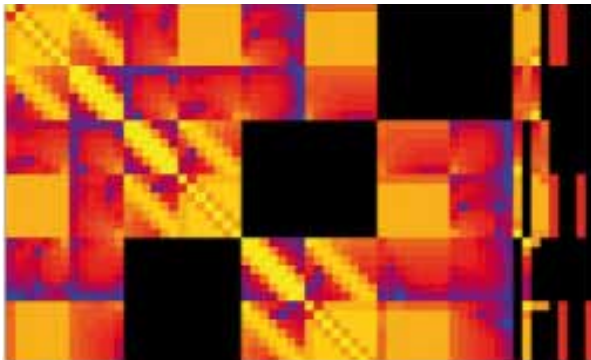

Fill pattern of a Schur complement matrix.

**PROJECT LEADERS**

B Carpentieri

**RESEARCH THEME**

Mathematical and computational methods for fluid flow analysis

**PARTICIPANTS**

B Carpentieri, YF Jing (Chengdu)

**COOPERATIONS**

University of Chengdu (China)

**FUNDED**

University	100%
FOM	-
STW	-
NWO Other	-
Industry	-
TNO	-
GTI	-
EU	-
Scholarships	-

**START OF THE PROJECT**

2010

**INFORMATION**

B Carpentieri

050 363 3939

b.carpentieri@rug.nl

**PROJECT AIM**

The project aims at developing Krylov subspace solvers for general nonsymmetric linear systems. Applications are sparse nonsymmetric problems in quantum mechanics and dense complex non-Hermitian problems in electromagnetic scattering. The work extends to the development of sparse eigensolvers for Maxwell's equations in the analysis of dielectric waveguides.

**PROGRESS**

The research on numerical methods for electromagnetics has been initiated by dr. B. Carpentieri, who joined the group in January 2010. This activity aims at studying numerical techniques for solving highly oscillatory problems. It has led to the development of novel Krylov subspace iterative solvers (BiCOR and CORS) and parallel preconditioners for high frequency analysis of large structures. In combination with the Fast Multipole Method, these solvers have been applied to the modeling of a full Airbus A318 aircraft (with EADS-CCR, Toulouse) and the NASA almond benchmark for Radar Cross Section calculation.

**DISSERTATIONS**

-

**SCIENTIFIC PUBLICATIONS**

1. B. Carpentieri, Y.-F. Jing and T.-Z. Huang, A novel Lanczos-type procedure for computing eigenelements of Maxwell and Helmholtz problems. *Progress In Electromagnetics Research PIER* 110 (2010) 81-101.
2. Yan-Fei Jing, Ting-Zhu Huang, Yong Duan and Bruno Carpentieri, A comparative study of iterative solutions to linear systems arising in quantum mechanics, *J. Comput. Phys.* 229(22) (2010) 8511-8520.
3. B. Carpentieri, Y.-F. Jing and T.-Z. Huang, Lanczos biconjugate A-orthonormalization methods for surface integral equations in electromagnetism. *PIERS Proceedings*, Xian, China, March 22-26 (2010), 678-682.
4. B. Carpentieri, Recent advances in fast integral solution methods for electromagnetic scattering analysis of high frequency structures. *Proceedings of the Workshop on Advances in Modeling and Optimization of High Frequency Structures*, Reykjavik University, Iceland, 21-22 August 2010, 2 pages.
5. B. Carpentieri, Y.-F. Jing and T.-Z. Huang, BiCOR and CORS: two fast convergent and economical iterative algorithms for solving nonsymmetric linear systems. *Proc. 2nd IMA Conf. Numerical Linear Algebra and Optimisation*, University of Birmingham, UK, 13-15 September 2010, 2 pages.

Surface current distribution on the Airbus A318 aircraft (with EADS, Toulouse).



**PROJECT AIM**

The project focuses on the aerodynamic optimization of turbine blades. The simulation approach builds on viscous-inviscid boundary-layer interaction. The numerical coupling between boundary layer and inviscid outer flow is similar to that used in our bio-medical project.

**PROGRESS**

An extensive analysis has been made of the mathematical character of the (interacting) boundary-layer equations and its consequences for the numerical solution process. In particular the (change in) direction of the underlying characteristics has been studied, with and without inviscid interaction. Focus has been on unsteady two-dimensional flow, and steady three-dimensional flow. The numerical algorithms are investigated with geometrically simple model problems: troughs and dents featuring separated flow.

**DISSERTATIONS**

-

**SCIENTIFIC PUBLICATIONS**

1. H.A. Bijleveld and A.E.P. Veldman, Rotorflow: a quasi-simultaneous interaction method for the prediction of aerodynamic flow over wind turbine blades. In: S. Voutsinas and T. Chaviaropoulos (eds.) TORQUE 2010: The Science of Making Torque from Wind, Heraklion, Crete (2010) pp. 247-254.

**PROJECTLEADERS**

AEP Veldman

**RESEARCHTHEME**

Mathematical and computational methods for fluid flow analysis

**PARTICIPANTS**

HA Bijleveld, AEP Veldman

**COOPERATIONS**

ECN

**FUNDED**

ECN

University -

FOM -

STW -

NWO Other -

Industry -

TNO -

GTI 100%

EU -

Scholarships -

**START OF THE PROJECT**

2008

**INFORMATION**

AEP Veldman

050 363 8988

a.e.p.veldman@rug.nl

www.math.rug.nl/~veldman

Wind turbine park.







Prof.dr.ir. ML van Hecke

The Granular and Disordered Media Group of Martin van Hecke investigates the slow flow and jamming of granulates, foams and macro emulsions. We focus on the interplay between mesoscopic organization and macroscopic flow features, and we combine video imaging with rheological measurements. We work closely together with the theory group of Vincenzo Vitelli. Topics we are currently working on include the flow and yielding of agitated granular media, sound in sand and the fluctuating flow of foam.

**PROJECT AIM**

An unusual characteristic of the jamming transition is the difference in scaling of the bulk and shear modulus of frictionless, soft particles near jamming. We probe this scaling by compressing a bidisperse foam monolayer sandwiched between a glass plate and a fluid surface. We also determine the weakly nonlinear effective bubble-bubble interaction in a 1D chain of bubbles under compression.

**PROGRESS**

We have been able to control the temperature of the entire experiment by using PID feedback, since changes in temperature cause the bubbles to change in size. Additionally, we have been able to show that under compression the foam system behaves nonlinearly. Video of each experiment is also taken to track the bubble motion under compression.

**DISSERTATIONS**

-

**SCIENTIFIC PUBLICATIONS**

1. Corwin, E et al. "A model of random packing of polydisperse frictionless spheres ", *Soft Matter*, 6, 2949-2959 (2010).
2. A.O.N. Siemens and M. van Hecke: Jamming: A Simple Introduction. *Physica A* 389, 4255 (2010).

**PROJECTLEADERS**

ML van Hecke

**RESEARCHTHEME**

Complex dynamics of fluids

**PARTICIPANTS**

Alexander Siemens

**COOPERATIONS**

-

**FUNDED**

University	-
FOM	100%
STW	-
NOW Other	-
Industry	-
TNO	-
GTI	-
EU	-
Scholarships	-

**START OF THE PROJECT**

2009

**INFORMATION**

A Siemens  
 071 527 5447  
 siemens@physics.leidenuniv.nl

**PROJECT LEADERS**

ML van Hecke

**RESEARCH THEME**

Complex dynamics of fluids

**PARTICIPANTS**

K Nichol

**COOPERATIONS**

-

**FUNDED**

University	-
FOM	100%
STW	-
NOW Other	-
Industry	-
TNO	-
GTI	-
EU	-
Scholarships	-

**START OF THE PROJECT**

2008

**INFORMATION**

K Nichol

+31 (0)71 527 5447

nichol@physics.leidenuniv.nl

**PROJECT AIM**

To probe the fluidization of granular media by flow.

**PROGRESS**

In 2010 we published in PRL our observations that flow, somewhere in a granular system, appears to fluidize the whole system. As a result, we find a novel state of granular matter, where the grains appear stationary, but collectively the material has zero yield stress.

**DISSERTATIONS**

-

**SCIENTIFIC PUBLICATIONS**

1. K. Nichol, A. Zanin, R. Bastien, E. Wandersman and M. van Hecke, Flow-induced Agitations Create a Granular Fluid, PRL 104 078302.

**PROJECT AIM**

To demonstrate and explain how proximity to jamming, the nonequilibrium transition to rigidity in disordered materials, controls the rheology of foams, emulsions and related materials, using both analytical and numerical methods.

**PROGRESS**

In 2010 we published in PRL a scaling model that, for the first time, clearly connects the physics of the static jamming transition to the rheology of disordered materials in shear flow. The model makes explicit predictions for nontrivial, nonlinear flow properties, relates microscopic physics to macroscopic observables, and has been confirmed both in numerics and experiments performed both at Leiden and elsewhere. Ongoing work is analyzing and confirming the assumptions underlying the model, as well as extending our numerical and analytical toolbox to describe oscillatory rheology.

**DISSERTATIONS**

-

**SCIENTIFIC PUBLICATIONS**

1. Model for the scaling of stresses and fluctuations in flows near jamming. B.P. Tighe, E. Woldhuis, J.J.C. Remmers, W. van Saarloos, and M. van Hecke. Phys. Rev. Lett. 105, 088303 (2010).
2. Couette flow of two-dimensional foams. G. Katgert, B.P. Tighe, M.E. Moebius, and M. van Hecke. EPL 90, 54002 (2010).
3. The force network ensemble for granular packings. B.P. Tighe, J.H. Snoeijer, T.J.H. Vlugt, and M. van Hecke. Soft Matter 6, 2908-2917 (2010).
4. Force balance in canonical ensembles of static granular packings. B.P. Tighe and T.J.H. Vlugt. J. Stat. Mech. P01015 (2010).

**PROJECTLEADERS**

ML van Hecke

**RESEARCHTHEME**

Complex dynamics of fluids

**PARTICIPANTS**

BP Tighe

**COOPERATIONS**

-

**FUNDED**

- University -
- FOM -
- STW -
- NOW Other -
- Industry -
- TNO -
- GTI -
- EU -
- Scholarships -

**START OF THE PROJECT**

2010

**INFORMATION**

BP Tighe  
 071 527 5520  
 btighe@ilorentz.org  
 ilorentz.org/~btighe



Prof.dr.ir. B Koren

In Koren's Scientific Computing group (Leiden University and Centrum Wiskunde & Informatica, Amsterdam), advanced numerical techniques are developed. Applications are computational problems in fluid dynamics, magnetohydrodynamics and risk management. At present, emphasis lies on the development of:

- ♦ immersed boundary methods for flow computations around complex moving and/or deforming bodies,
- ♦ a computational method for wind-farm aerodynamics, and
- ♦ a numerical method for the Hamilton-Jacobi-Bellman equation, for the control of the heights of primary dikes in the Netherlands. Research has also been started on the investigation of:
  - ♦ Edge Localized Modes in tokamak plasmas, by further development and application of computational tools.

# DEVELOPMENT OF AN IMMERSED BOUNDARY METHOD FOR THE EULER EQUATIONS

## PROJECT AIM

Development of an Euler-flow method, in which bodies of arbitrary shape and motion are immersed in a fixed, uniform, cartesian finite-volume grid, and in which the corresponding boundary conditions are embedded in the neighboring fixed-grid fluxes.

## PROGRESS

The new two-dimensional immersed-boundary algorithm for convection problems, that has been proposed and analyzed last year, was extended to the Euler equations of gas dynamics. In the algorithm, the computational domain is divided into equally sized, rectangular finite volumes that are fixed in space. Boundaries are approximated by straight line segments that may be inside the cells. The boundary conditions are embedded in the relevant fluxes in the immediate neighborhood. The Euler-flow test case considered is the standard case of a massive, solid circular cylinder in a channel with flat parallel walls, that is being hit and set into motion by a blast wave. The cylinder movement is described by Newton's second law of motion and by collision laws for when it hits the channel walls.

## DISSERTATIONS

-

## SCIENTIFIC PUBLICATIONS

1. Y. Hassen and B. Koren, A novel 2D finite-volume method for convection problems with embedded moving boundaries, Proceedings ICFD Conference on Numerical Methods for Fluid Dynamics, Reading (2010).

## PROJECT LEADERS

B Koren

## RESEARCH THEME

Mathematical and computational methods for fluid flow analysis

## PARTICIPANTS

YJ Hassen

## COOPERATIONS

Delft Research Center for Computational Science and Engineering (DRC-CSE) and CWI

## FUNDED

TU Delft (DRC-CSE) and CWI University	50%
FOM	-
STW	-
NWO Other	-
Industry	50%
TNO	-
GTI	-
EU	-
Scholarships	-

## START OF THE PROJECT

2006

## INFORMATION

B Koren

020 592 4114

Barry.Koren@cw.nl

<http://homepages.cwi.nl/~barry>

**PROJECT LEADERS**

B Koren

**RESEARCH THEME**

Mathematical and computational methods for fluid flow analysis

**PARTICIPANTS**

B Sanderse

**COOPERATIONS**

ECN and CWI

**FUNDED**

ECN and CWI

University -

FOM -

STW -

NWO Other -

Industry 100%

TNO -

GTI -

EU -

Scholarships -

**START OF THE PROJECT**

2008

**INFORMATION**

B Koren

020 592 4114

Barry.Koren@cw.nl

<http://homepages.cwi.nl/~barry>

**PROJECT AIM**

The Dutch government plans that a significant portion of the Dutch future energy need is to be produced by wind farms at the North Sea. A wind farm is a large set of wind turbines, often positioned in some matrix form. Various research questions still exist with respect to wind farms; economical, ecological and technological. A major technological question is how to position and design the separate wind turbines, such that the energy production of the wind farm as a whole is maximal. The goal of this project is to make a step towards answering this question.

**PROGRESS**

Research focused on time-integration methods for the unsteady incompressible Navier-Stokes equations, particularly on:

- energy-conserving, high-order time-accurate Gauss-Legendre Runge-Kutta methods;
- computationally efficient Runge-Kutta methods for high-order temporal accuracy of pressure;
- energy conservation by linear implicit midpoint and linear implicit four-stage Runge-Kutta methods; and
- a general framework for Runge-Kutta methods applied to incompressible Navier-Stokes.

Research on symmetry-preserving finite-volume methods was also continued. A paper on it was presented at the ECCOMAS CFD Conference in Lisbon. Further, a review paper on computational wind-farm aerodynamics was finished and accepted for publication by the journal Wind Energy.

**DISSERTATIONS**

-

**SCIENTIFIC PUBLICATIONS**

1. B. Sanderse and B. Koren, Analysis of fourth-order accurate symmetry-preserving boundary conditions for the incompressible Navier-Stokes equations, Proceedings of the ECCOMAS Computational Fluid Dynamics Conference (ECCOMAS CFD 2010), Lisbon, on CD-ROM (2010).

# INVESTIGATION OF EDGE LOCALIZED MODES BY FURTHER DEVELOPMENT AND APPLICATION OF COMPUTATIONAL TOOLS

## PROJECT AIM

Edge Localized Modes (ELMs) are disruptive magnetohydrodynamic (MHD) instabilities observed in torus-shaped fusion devices in which an extremely hot plasma is confined magnetically (tokamaks) for the eventual goal of energy production. The project aim is to acquire a deeper understanding of the nonlinear development of ELMs. This is required to predict their impact on next-generation tokamaks, like ITER, and to find ways to control or trigger ELMs in an early stage of their development.

## PROGRESS

Research on the MHD equilibrium and spectrum of toroidally rotating tokamak plasmas was continued. Three journal papers were prepared on it, submitted and accepted for publication. Some additional research on the spectrum of toroidally rotating tokamak plasmas in equilibrium was started. Further, a successful start was made with the use of the full-MHD JOREK code for the present ELMs research.

## DISSERTATIONS

-

## SCIENTIFIC PUBLICATIONS

-

## PROJECT LEADERS

B Koren, HJ de Blank

## RESEARCH THEME

Complex dynamics of fluids

## PARTICIPANTS

JW Haverkort

## COOPERATIONS

FOM Institute for Plasma Physics  
"Rijnhuizen", CWI

## FUNDED

FOM (FOM Program 120, "Burn Control")

University	-
FOM	100%
STW	-
NWO Other	-
Industry	-
TNO	-
GTI	-
EU	-
Scholarships	-

## START OF THE PROJECT

2009

## INFORMATION

JW Haverkort

020 592 4161

J.W.Haverkort@cwI.nl

homepages.cwi.nl/~haverkor/



**PROJECTLEADERS**

B Koren, HJ de Blank

**RESEARCHTHEME**

Complex dynamics of fluids

**PARTICIPANTS**

B van Es

**COOPERATIONS**

FOM Institute for Plasma Physics  
"Rijnhuizen", CWI

**FUNDED**

FOM (FOM Program 120, "Burn  
Control")

University	-
FOM	100%
STW	-
NWO Other	-
Industry	-
TNO	-
GTI	-
EU	-
Scholarships	-

**START OF THE PROJECT**

2010

**INFORMATION**

B Koren  
020 592 4114  
Barry.Koren@cw.nl  
<http://homepages.cwi.nl/~barry>

**PROJECT AIM**

Edge Localized Modes (ELMs) are disruptive magnetohydrodynamic (MHD) instabilities observed in torus-shaped fusion devices in which an extremely hot plasma is confined magnetically (tokamaks) for the eventual goal of energy production. The project aim is to find ways to control and mitigate ELMs in an early stage of their development.

**PROGRESS**

In tokamak plasmas, diffusion coefficients may differ many orders of magnitude in distinct directions. The difference is particularly large between directions parallel and normal to magnetic field surfaces. Research focused on special discretization methods for 2D model diffusion problems with strong anisotropic diffusion. Further, a fundamental study was started to find the complete eigenstructure (eigenvalues, eigenvectors and Riemann invariants) of the full, ideal MHD equations. The aim is: the development of a new approximate Riemann solver for the ideal MHD equations with high physical content. Two-fluid flow aspects may become important in this. A paper on two-fluid flow (not yet MHD) was prepared and accepted by the Journal of Computational Physics.

**DISSERTATIONS**

-

**SCIENTIFIC PUBLICATIONS**

1. J.J. Kreeft and B. Koren, A new formulation of Kapila's five-equation model for compressible two-fluid flow, and its numerical treatment, Journal of Computational Physics, 229, 6220-6242 (2010).





Prof.dr.ir. J.L. van Leeuwen

The current main theme of the Experimental Zoology Group is the biomechanics and development of the locomotion and feeding system in fish and other vertebrates (such as amphibians, reptiles and horses), in an evolutionary perspective and in relation to animal welfare. Mechanisms of development, growth and adaptation are studied at several levels of structural organisation, from molecules to ecosystem. This integrates several research lines such as (1) architectural organisation and remodelling of muscle and skeletons in larval and juvenile fish and horses, (2) biofluid dynamics of swimming in larval fish, (3) effects of training on growth of the muscular system, signified by for instance molecular expression patterns, and (4) structural development and function of the equilibrium system. We have also an ecomorphology line of research that relates form and function at the organismal level to the actual niches and adaptive radiation in the natural environment.

### **THE FOLLOWING RESEARCH LINES ARE CARRIED OUT**

1. Biomechanics of development in teleost fish
2. Biofluid dynamics of swimming and flight
3. Biomechanics of horses
4. Biomechanics of tongues and tentacles
5. Biomechanics of sensory systems
6. Biofluid dynamics of sponges and tunicates

**PROJECT AIM**

We study vortex dynamic strategies of swimming and flying. In particular, we determine whether animals tune their locomotory kinematics to exploit the dynamics of vortices to maximize performance and to simplify control. We explore to what extent such strategies are adopted by zebrafish larvae and fruit flies, that propel themselves in a similar Reynolds regime. We aim to unravel whether fish and insects exploit common vortex dynamic mechanisms.

**PROGRESS**

In the past year, we published our FEM analysis of a realistic dragonfly wing model (1). The FEM model is automatically generated from a micro-CT scan of a Dragonfly forewing. The results show that dragonfly wings have natural frequencies several times higher than the flapping frequency, contrary to the previous results obtained with more limited semi 2D wing models. We also showed that the vortex wakes of flapping foils can be chaotic, which makes the forces they generate harder to predict due to the limited forecast horizon (2). Lentink co-edited a special issue on bio-inspired flight for the Journal of Bioinspiration & Biomimetics with papers on insect, maple seed, bird, gecko and snake flight and robots inspired there-off (3). Articles from this issue were featured in the world wide media including the Economist and the New York Times. Finally team Lentink won the Dutch Academic Year Prize 2010 with their project "Vliegkunstenaars" based on the natural flight research of Lentink and co-workers. This project will educate the Dutch general public how to use high-speed video cameras to film flying animals and plant seeds in their natural environment and study their flight in slow-motion. Participants can use our 30 high-speed Casio cameras and our Phantom v710 camera. The Phantom camera can be operated for up to 10 hrs in the field and can film in HD at 7500 fps in full color using lenses from extreme macro to tele. The project is support by The Dutch Academic year Prize, Wageningen University, Vision Research, Casio, and the Dutch National Police Force. More information: [www.vliegkunstenaars.wur.nl](http://www.vliegkunstenaars.wur.nl). Finally, Van Leeuwen wrote a perspectives paper for Science on the explosive spore release in Sphagnum mosses, in which a ring-vortex is formed in a highly unsteady particle flow (4).

**DISSERTATIONS**

1. D. Lentink (2008) Exploring the Biofluidynamics of Swimming and Flight.

**SCIENTIFIC PUBLICATIONS**

1. Jongerius, S.R.; Lentink, D. (2010) Structural Analysis of a Dragonfly Wing. *Experimental Mechanics* 50 (9), 1323 - 1334.
2. Lentink, D.; van Heijst, G.J.F.; Muijres, F.T.; van Leeuwen, J.L. (2010) Vortex interactions with flapping wings and fins can be unpredictable. *Biology Letters* 6 (3), 394 - 397.
3. Lentink, D.; Biewener, A.A. (2010) Editorial: Nature-inspired flight - beyond the leap. *Bioinspiration & biomimetics* 5 (4), 040201.
4. Van Leeuwen, J.L. (2010) Launched at 36,000g. *Science* 329 (5990), 395 - 396.

**PROJECTLEADERS**

JL van Leeuwen, D Lentink

**RESEARCHTHEME**

Complex dynamics of fluids

**PARTICIPANTS**

D Lentink

**COOPERATIONS**

Prof. Dr. M.H. Dickinson (Caltech)

Prof.dr.ir. G.J.H. van Heijst (TUE)

Prof.dr. U.K. Müller (Fresno)

Prof.dr. H. Liu (Chiba)

**FUNDED**

University	25%
FOM	-
STW	-
NWO Other	75%
Industry	-
TNO	-
GTI	-
EU	-
Scholarships	-

**START OF THE PROJECT**

start PhD project: 2004 (diss. 2008)

start NWO ALW: 2007

**INFORMATION**

D Lentink

0317 4 83965

[david.lentink@wur.nl](mailto:david.lentink@wur.nl)

JL van Leeuwen

0317 4 82267

[johan.vanleeuwen@wur.nl](mailto:johan.vanleeuwen@wur.nl)

<http://www.ezo.wur.nl/UK>



**PROJECT LEADERS**

JL van Leeuwen, D Lentink

**RESEARCH THEME**

Complex dynamics of fluids

**PARTICIPANTS**

S Henrion

**COOPERATIONS**

T. Vercruyssen MSc, Biomechanical Engineering, TU Delft

**FUNDED**

Delphi Consortium and WU

University 10%

FOM -

STW -

NWO Other -

Industry 90%

TNO -

GTI -

EU -

Scholarships -

**START OF THE PROJECT**

2010

**INFORMATION**

S Henrion

06 38989546

sebastian.henrion@wur.nl

www.ezo.wur.nl/UK/Staff/Henrion/

**PROJECT AIM**

Undulating fin propulsion as used by seahorses and sepia (nearly rigid-bodied animals) offers many advantages: from stable, low speed swimming, hovering at certain depths to an unsurpassed manoeuvrability. However, the mechanisms of thrust production and manoeuvring through undulating fins attached to a rigid body are largely unknown. The aim at a fundamental biological (biofluidynamics) level is to unravel the mechanisms between fin and body kinematics on the aforementioned animals and their locomotory behaviour. Later on, PIV will be used to analyse the fluid-dynamics of undulatory fin propulsion. The knowledge gained from locomotion and fluid-dynamic experiments with the animals will serve as a guideline for the design of a multifunctional, highly manoeuvrable bio-inspired underwater sensor platform. This underwater robot will be optimized with respect to efficiency and manoeuvrability, both by free swimming experiments and hydrodynamic modelling.

**PROGRESS**

Biological research

This project started August 2010. So far, much effort was put in the development of an experimental set up, including:

- Installation of aquaria for holding seahorses, pipefish and sepia.
- Design of the first locomotion experiment: high-speed video setup for the analysis of fin and body kinematics of start and stop maneuvers, and steady forward swimming (seahorses).
- Initiation of several graduation projects on seahorse and sepia locomotory behaviour and training (essential for the design of relevant locomotion experiments).
- Design of drag measurements on seahorses and sepia.
- Implementation and further development of Lighthill-Blake model (analytical model for thrust production by undulatory swimming).

Technical research

An undulatory fin is being designed to enable efficiency measurements and free swimming tests, including start and stop manoeuvres and steady forward swimming. The results of this experiment will lead to information on the robot stability, available and optimal kinematic variable space, maneuverability and input for the integrative control model of the robot (the latter is developed at TU Delft).

**DISSERTATIONS**

-

**SCIENTIFIC PUBLICATIONS**

-





Prof.dr. LRM Maas

Research in this theme focuses on the interactions between the water motion, sediment transport and bottom changes in coastal seas and estuaries. Both sandy and mud-dominated coastal systems are investigated. The following approaches are used to gain more understanding of hydrodynamic and morphodynamic processes: collection and analysis of field observations, simulations with complex numerical models and interpretation of these results, development and analysis of idealized mathematical models.

## PROJECT AIM

To study the appearance and robustness of internal wave attractors in a variety of two and three-dimensional experimental settings. Also attention is paid to the implications of the presence of wave attractors for the transport of fluid and dissolved substances.

## PROGRESS

Internal wave attractors have been demonstrated to occur over a (continuous) range of frequencies, under a range of perturbations (of both geometry and stratification) and both in two as well as in three-dimensional circumstances. The latter was shown to occur by tomographic methods.

## DISSERTATIONS

1. Jeroen Hazewinkel, Attractors in stratified fluids (12 March 2010).

## SCIENTIFIC PUBLICATIONS

1. Hazewinkel J.; Maas, L.R.M.; Dalziel, S.B. (2010) Tomographic reconstruction of internal wave patterns in a paraboloid. Experiments in Fluids (in press).
2. Hazewinkel, J.; Tsimitri, C.; Maas, L.R.M. and Dalziel, S.B. (2010). Observations on the robustness of internal wave attractors to perturbations. Physics of Fluids 22, 107102.

## PROJECT LEADERS

LRM Maas, A Doelman, S Dalziel

## RESEARCH THEME

Complex structures of fluids

## PARTICIPANTS

J Hazewinkel

## COOPERATIONS

Dr. S Dalziel (Cambridge UK)

## FUNDED

University	-
FOM	50%
STW	-
NWO Other	50%
Industry	-
TNO	-
GTI	-
EU	-
Scholarships	-

## START OF THE PROJECT

2006

## INFORMATION

LRM Maas

0222 369419

maas@nioz.nl

www.nioz.nl/maas



**PROJECT LEADERS**

LRM Maas, Th Gerkema, H van Haren

**RESEARCH THEME**

Complex dynamics of fluids

**PARTICIPANTS**

A Rabitti

**COOPERATIONS**

Prof. Th. Dauxois (ENS Lyon)

**FUNDED**

University	-
FOM	-
STW	-
NWO Other	100%
Industry	-
TNO	-
GTI	-
EU	-
Scholarships	-

**START OF THE PROJECT**

2009

**INFORMATION**

LRM Maas  
0222 369419  
maas@nioz.nl  
www.nioz.nl/maas

**PROJECT AIM**

Aim is to unravel the dynamics of the equatorial region ( $\pm 1$  degree) that differs dynamically from other parts of the ocean. Attention is paid to the possibility of internal wave attractors being excited in off-equatorial regions, affecting the equatorial zonal mean flow. This is done by (1) in situ measurements of physical and acoustic fields along a cross-equatorial transect; (2) use of satellite data; (3) comparison to theoretical and numerical model predictions; and (4) by development of these models.

**PROGRESS**

Internal wave dynamics has been studied both in theory and experiments. A new experiment demonstrates that the free internal wave regime extends from zero frequency to the buoyancy frequency. Internal wave ray dynamics in three-dimensional spherical or spherical shell fluid domains has been studied showing that rays may be trapped on certain meridional planes. This stresses the importance of earlier studies that presumed motion to be confined to meridional planes.

**DISSERTATIONS**

-

**SCIENTIFIC PUBLICATIONS**

-



# WHO & WHERE

---





### **Mechanical Engineering and Marine Technology**

*Mechanical Engineering - Mekelweg 2 - 2628 CD Delft*

- ◆ Prof.dr.ir. J Westerweel 015 278 6887 j.westerweel@tudelft.nl
- Prof.dr. JCR Hunt 015 278 2904 jcrh@cpom.ucl.ac.uk
- Prof.dr.ir. G Ooms 015 278 1176 g.ooms@tudelft.nl
- Prof.dr.ir. B Eckhardt 015 278 2904 bruno.eckhardt@physik.uni-marburg.de
- ◆ Prof.dr.ir. BJ Boersma 015 278 7979 b.j.boersma@tudelft.nl

*Marine Technology - Mekelweg 2 - 2628 CD Delft*

- ◆ Prof.dr.ir. RHM Huijsmans 015 278 2889 r.h.m.huijsmans@tudelft.nl
- Prof.dr.ir. TJC van Terwisga 015 278 6860 t.v.terwisga@tudelft.nl
- ◆ Prof.dr.ir. C van Rhee 015 278 3973 c.vanrhee@tudelft.nl

### **Electrical Engineering, Mathematics and Computer Science**

*Applied Mathematical Analysis - Mekelweg 4 - 2628 CD Delft*

- ◆ Prof.dr.ir. C Vuik 015 278 5530 c.vuik@tudelft.nl
- Prof.dr.ir. P Wesseling 015 278 3631 p.wesseling@tudelft.nl
- ◆ Prof.dr.ir. AW Heemink 015 278 5813 a.w.heemink@tudelft.nl

### **Applied Science**

*Multi-Scale Physics - Leeghwaterstraat 39 - 2628 CB Delft*

- ◆ Prof.dr.ir. HEA van den Akker 015 278 5000 h.e.a.vandenakker@tudelft.nl
- Prof.dr.ir. S Sundaresan 015 278 5000 sundar@princeton.edu
- Prof.dr. AP Siebesma 015 278 4720 a.p.siebesma@tudelft.nl
- Prof.dr. HJJ Jonker 015 278 6157 h.j.j.jonker@tudelft.nl
- ◆ Prof.dr.ir. CR Kleijn 015 278 2835 c.r.kleijn@tudelft.nl
- ◆ Prof.dr. RF Mudde 015 278 2834 r.f.mudde@tudelft.nl
- Prof.dr.ir. RAWM Henkes 015 278 1323 r.a.w.m.henkes@tudelft.nl
- ◆ Prof.dr. DJEM Roekaerts 015 278 2470 d.j.e.m.roekaerts@tudelft.nl

*Physics of Nuclear Reactors - Mekelweg 15 - 2629 JB Delft*

- ◆ Prof.dr.ir. THJJ van der Hagen 015 278 2105 t.h.j.j.vanderhagen@tudelft.nl

*DelftChemTech - Julianalaan 136 - 2628 BL Delft*

- ◆ Prof.dr.ir. M-O Coppens 015 278 4399 m.o.coppens@tudelft.nl

### **Aerospace Engineering**

*Kluyverweg 2 - 2600 GB Delft*

- ◆ Prof.dr.ir. H Bijl 015 278 5373 h.bijl@tudelft.nl
- Prof.dr.ir. F Scarano 015 278 9111 f.scarano@tudelft.nl
- Prof.dr.ir. PG Bakker 015 278 5907 p.g.bakker@tudelft.nl

### **Civil Engineering and Geosciences**

*Stevinweg 1 - 2628 CN Delft*

- ◆ Prof.dr.ir. GS Stelling 015 278 5426 g.s.stelling@tudelft.nl
- Prof.dr.ir. WSJ Uijtewaal 015 278 1371 w.s.j.ujtewaal@tudelft.nl

TUE | 040 247 9111 | PO Box 513 - 5600 MB Eindhoven

---

### Applied Physics

- ◆ Prof.dr.ir. AA Darhuber 040 247 2046 a.a.darhuber@tue.nl
- Prof.dr. F Toschi 040 247 3911 f.toschi@tue.nl
- Prof.dr.ir. MEH van Dongen 040 247 3194 m.e.h.v.dongen@tue.nl
- ◆ Prof.dr.ir. GJF van Heijst 040 247 2722 g.j.f.v.heijst@tue.nl
- Prof.dr. H Kelder 040 247 5212 h.kelder@tue.nl | kelder@knmi.nl
- Prof.dr. HJH Clercx 040 247 2680 h.j.h.clercx@tue.nl
- Prof.dr.ir. BJ Geurts 040 247 4285 b.j.geurts@tue.nl

### Mechanical Engineering

- ◆ Prof.dr. LPH de Goey 040 247 2938 l.p.h.d.goey@tue.nl
- Prof.dr.ir. RSG Baert 040 247 3167 r.s.g.baert@tue.nl
- Prof. LEM Aldén 040 247 2938 marcus.alden@forbrf.lth.se
- ◆ Prof.dr.ir. JJH Brouwers 040 247 5397 j.j.h.brouwers@tue.nl
- ◆ Prof.dr.ir. AA van Steenhoven 040 247 2132 a.a.v.steenhoven@tue.nl
- Prof.dr. AH Dietzel 040 247 5235 a.h.dietzel@tue.nl
- Prof.dr. HA Zondag 040 247 2719 h.a.zondag@tue.nl

### Mathematics and Computer Science

- ◆ Prof.dr. RMM Mattheij 040 247 2080 r.m.m.mattheij@tue.nl
- Prof.dr. F Toschi 040 247 3911 f.toschi@tue.nl
- ◆ Prof.dr.ir. CJ van Duijn 040 247 2855 c.j.v.duijn@tue.nl
- Prof.dr. JJM Slot 040 247 2184 j.j.m.slot@tue.nl

### Biomedical Engineering

- ◆ Prof.dr.ir. FN van de Vosse 040 247 4218 f.n.v.d.vosse@tue.nl

### Chemical Engineering

#### *Multiphase Reactors Group*

- ◆ Prof.dr.ir. JAM Kuipers 040 247 4158 j.a.m.kuipers@tue.nl

#### *Chemical Process Intensification*

- ◆ Prof.dr.ir. M van Sint Annaland 040 247 2241 m.v.sintannaland@tue.nl

UT | 053 489 9111 | PO Box 217 - 7500 AE Enschede

---

### Applied Physics

- ◆ Prof.dr. WJ Briels 053 489 2947 w.j.briels@utwente.nl
- ◆ Prof.dr. D Lohse 053 489 8076 d.lohse@utwente.nl
- Prof.dr. A Prosperetti 053 489 9111 prosperetti@jhu.edu
- Prof.dr.ir. L van Wijngaarden 053 489 3086 l.vanwijngaarden@tnw.utwente.nl
- Prof.dr. R Verzicco 053 489 2470 r.verzicco@utwente.nl
- ◆ Prof.dr. F Mugele 053 489 3094 f.mugele@utwente.nl

### Electrical Engineering, Mathematics and Computer Science

#### *Mathematical Sciences*

- ◆ Prof.dr.ir. EWC van Groesen 053 489 3413 e.w.c.vangroesen@utwente.nl
- ◆ Prof.dr.ir. JWW van der Vegt 053 489 5628 j.j.w.vandervegt@utwente.nl
- Prof.dr. HJH Clercx 053 489 3408 h.j.h.clercx@utwente.nl
- Prof.dr.ir. BJ Geurts 053 489 4125 b.j.geurts@utwente.nl
- Prof.dr.ir. JGM Kuerten 040 247 2362 j.g.m.kuerten@tue.nl

## Engineering Technology

### *Mechanical Engineering*

- ◆ Prof.dr.ir. HWM Hoeijmakers 053 489 4838 h.w.m.hoeijmakers@utwente.nl
- ◆ Prof.dr.ir. A Hirschberg 040 247 2163 a.hirschberg@tue.nl
- ◆ Prof.dr.ir. ThH van der Meer 053 489 2562 t.h.vandermeer@utwente.nl
- ◆ Prof.dr. S Luding 053 489 4212 s.luding@ctw.utwente.nl

### *Water Engineering and Management*

- ◆ Prof.dr. SJMH Hulscher 053 489 4256 s.j.m.h.hulscher@utwente.nl

RUG | 050 363 9111 | PO Box 800 - 9700 AV Groningen

---

## Mathematics and Natural Sciences

### *Chemistry*

- ◆ Prof.dr.ir. HB Levinsky 050 363 4544 h.b.levinsky@chem.rug.nl

### *Mathematics*

- ◆ Prof.dr. AEP Veldman 050 363 3988 veldman@math.rug.nl

RUN | 024 361 6161 | PO Box 9010 - 6525 ED Nijmegen

---

## Science

### *Applied Molecular Physics*

- ◆ Prof.dr. JJ ter Meulen 024 365 3022 h.termeulen@science.ru.nl
- ◆ Prof.dr.ir. W van de Water 040 247 3443 w.v.d.water@tue.nl

UL | 071 527 5505 | PO Box 9506 - 2300 RA Leiden

---

## Mathematics and Natural Sciences

### *Kamerlingh Onnes Lab*

- ◆ Prof.dr. M van Hecke 071 527 5482 mvhecke@physics.leidenuniv.nl

### *Mathematical Institute*

- ◆ Prof.dr.ir. B Koren 020 592 4114 barry.koren@math.leidenuniv.nl

WUR | 0317 477 477 | PO Box 9101 - 6701 BH Wageningen

---

## Applied Mathematics

### *Biometris*

- ◆ Prof.dr. J Molenaar 0317 486042 jaap.molenaar@wur.nl

## Experimental Zoology Group

### *Animal Sciences*

- ◆ Prof.dr.ir. JL van Leeuwen 0317 482267 johan.vanleeuwen@wur.nl

UU | 030 253 9111 | PO Box 80125 - 3508 TC Utrecht

---

## Physics and Astronomy

### *Institute for Marine and Atmospheric research Utrecht (IMAU)*

- ◆ Prof.dr. LRM Maas 0222 369 419 maas@nioz.nl

### Board of Directors

Prof.dr.ir. G Lodewijks (TUD, Chairman)	015 278 9111	g.lodewijks@tudelft.nl
Ir. AJ Dalhuijsen (VSL)	015 269 1500	adalhuijsen@vsl.nl
Prof.dr.ir. CR Kleijn (TUD)	015 278 2835	c.r.kleijn@tudelft.nl
Prof.dr.ir. JJW van der Vegt (UT)	053 489 5628	j.j.w.vandervegt@utwente.nl
Prof.dr.ir. GMW Kroesen (TUE)	040 247 4357	g.m.w.kroesen@tue.nl

### Management Team

Prof.dr.ir. GJ van Heijst (TUE)	040 247 2722	g.j.f.v.heijst@tue.nl
Prof.dr. D Lohse (UT)	053 489 8076	d.lohse@utwente.nl
Prof.dr.ir. J Westerweel (TUD)	015 278 6887	j.westerweel@tudelft.nl

### Industrial Board

Ir. Veraar (TNO Defence and Safety)	015 284 3395	ronald.veraar@tno.nl
Dr.ir. J Baltussen (AKZO-Nobel)	026 366 1479	joop.baltussen@akzonobel-chemicals.com
B Vreman		- bert.vreman@akzonobel.com
Ir. A van Berkel (TNO Science & Industry)	055 549 3759	arij.vanberkel@tno.nl
Ir. AJ Dalhuijsen (VSL)	015 269 1500	adalhuijsen@vsl.nl
Prof.dr.ir. J den Toonder (Philips)	040 274 3306	jaap.den.toonder@philips.com
Dr. RPJ Duursma (Tata Steel)	0251 492 363	rene.duursma@tatasteel.com
Ir. J Longo (ESA/ESTEC)	071 565 4781	jose.longo@esa.int
Ir. G Hommersom (Dow Benelux)	0115 67 4102	ghommersom@dow.com
Dr.ir. J Janssen (Unilever)	010 460 6324	jo.janssen@unilever.com
Dr.ir. M Veenman (DSM)	046 476 1240	Maurice.Veenman@dsm.com
Ir. JJ Meerman (Teijin Aramid)	088 268 9367	hans.meerman@teijinaramid.com
Prof.dr.ir. AE Mynett (Unesco)	015 285 8580	a.mynett@unesco-ihe.org
Dr. B Oskam (NLR)	020 511 3357	oskam@nlr.nl
Dr.ir. HJ Prins (Marin)	0317 493 405	h.j.prins@marin.nl
Ir. H Reinten (Oce)	077 359 4061	hans.reinten@oce.com
Ir. M Riepen (ASML)	040 268 3000	michel.riepen@asml.nl
Dr. HJ Riezebos (Gasunie)	050 521 2583	h.j.riezebos@gasunie.nl
Ir. G Saccoccia (ESA/ESTEC)	071 565 4781	giorgio.saccoccia@esa.int
Ir. Van Garrel (NRG Petten)	0224 564170	vangarrel@ecm.nl
Ir. P Veenstra (Shell)	020 630 3384	peter.veenstra@shell.com
Ir. H Vos (TNO Science & Industry)	015 269 2311	hugo.vos@tno.nl
F Visser (Flowserve)		- fvisser@flowserve.com

### PhD Students Representatives

K Nichol (LU)	071 527 5482	nichol@physics.leidenuniv.nl
V Koschatzky (TUD)	015 278 2861	v.koschatzky@tudelft.nl
M Boot (TUE)	040 247 5689	m.d.boot@tue.nl
J Thies (RUG)	050 363 6474	jonas@math.rug.nl
M Mirzaei (RUN)	024 365 32880	m.mirzaei@science.ru.nl
I Roghair (UT)	053 489 9111	i.roghair@utwente.nl



## PhD Students Contact Group

h.j.l.van.der.heiden@rug.nl

TUD	AJ Greidanus	015 278 4194	a.j.greidanus@tudelft.nl
	M Olivero	015 278 9479	m.olivero@tudelft.nl
	T Collignon	015 278 7608	t.p.collignon@tudelft.nl
	R Malekzadeh	015 278 3210	r.malekzadeh@tudelft.nl
	D Violato	015 278 5902	d.violato@tudelft.nl
	P Smit	015 278 9111	p.b.smit@tudelft.nl
TUE	BJ Brasjen	040 247 5892	b.j.brasjen@tue.nl
	R Zegers	040 247 2393	r.p.c.zegers@tue.nl
	PHMW Panhuis	040 247 5515	p.h.m.w.panhuis@tue.nl
	HM Slagter	040 247 3685	h.m.slagter@tue.nl
UT	R de Ruiter	053 489 1096	r.deruiter-1@tnw.utwente.nl
	D van Gils	053 489 4682	d.p.m.vangils@utwente.nl
	W Kranenburg	053 489 2959	w.m.kranenburg@ctw.utwente.nl
	DF van Eijkeren	053 489 2482	d.f.vaneijkeren@utwente.nl
	AA Verbeek	053 489 2507	a.a.verbeek@utwente.nl
RUG	HJL van der Heiden	050 363 3970	h.j.l.van.der.heiden@rug.nl
RUN	-	-	-
LU	-	-	-
UU	-	-	-

### JM Burgerscentrum (The Netherlands)

Prof.dr.ir. G Ooms, scientific director 015 278 1176 g.ooms@tudelft.nl  
I Hoekstein-Philips, JMBC secretariat 015 278 3216 jmburgerscentrum@tudelft.nl  
Mekelweg 2  
2628 CD Delft

### Burgers Program Maryland

James M Wallace, Professor, Dept. of Mechanical Engineering  
[www.eng.umd.edu/~wallace](http://www.eng.umd.edu/~wallace)  
Gemstone Program Director  
[www.gemstone.umd.edu/](http://www.gemstone.umd.edu/)  
Chair, Burgers Program for Fluid Dynamics  
[www.burgers.umd.edu/](http://www.burgers.umd.edu/)  
T 301 314 6695  
F 301 314 8469  
E [wallace@eng.umd.edu](mailto:wallace@eng.umd.edu)

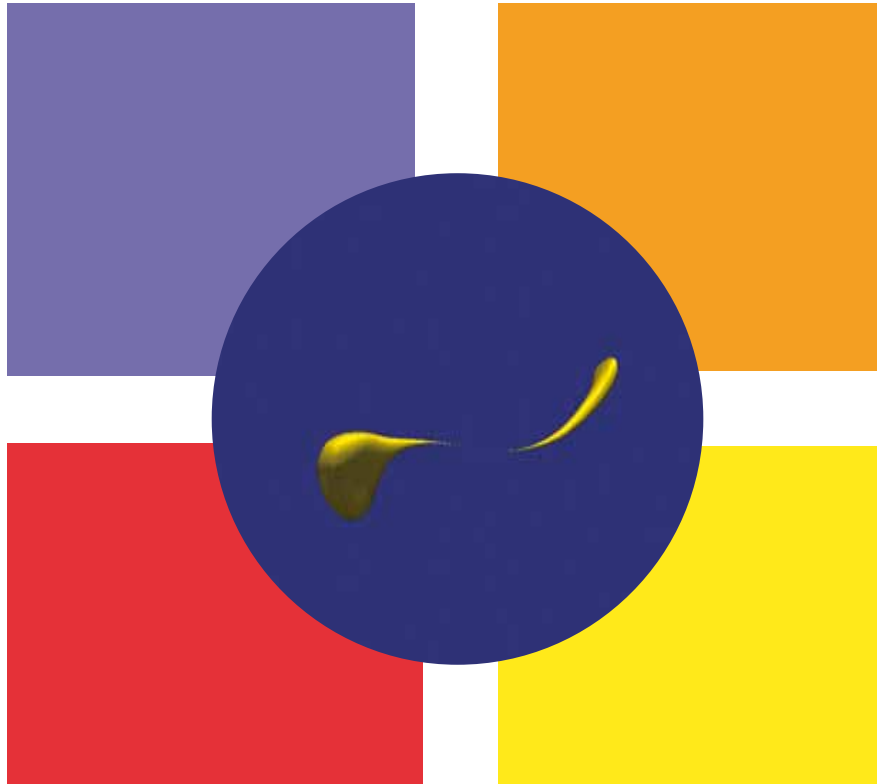

JMBC Annual Report & Research Programme  
2010-2011