

2013

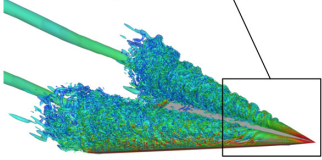

2014

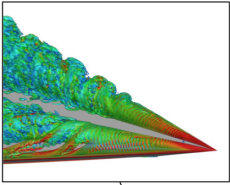
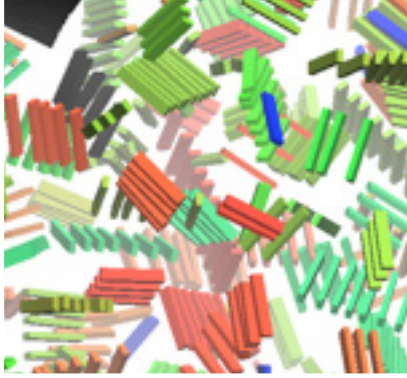
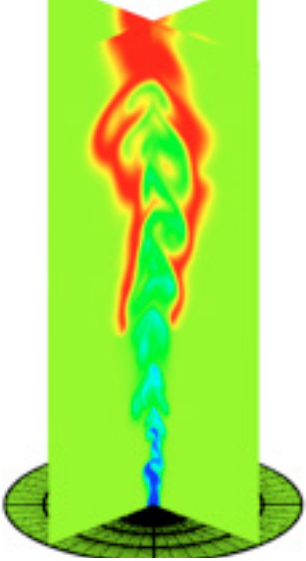
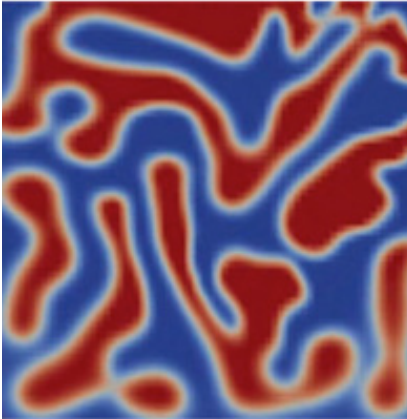

ANNUAL REPORT & RESEARCH PROGRAMME

ANNUAL REPORT & RESEARCH PROGRAMME 2013-2014

JM Burgerscentrum
Research School for Fluid Mechanics

TUD, TUE, UT, RUG, WUR, UU

© May 2014, JM Burgerscentrum

All rights reserved. No part of this publication may be reproduced in any form by print, photoprint, microfilm or any other means without written permission of the rightful claimant(s). This restriction concerns the entire publication or any part of it.

CORRESPONDENCE FOR REPRODUCTION

JM Burgerscentrum
Attn. Mrs. I Hoekstein
Mekelweg 2
2628 CD Delft
The Netherlands
T 015 278 3216
F 015 278 2979
E jmburgerscentrum@tudelft.nl
www.jmburgerscentrum.nl

Burgers Program for Fluid Dynamics (University of Maryland, USA)
www.enme.umd.edu/burgers/

Contributions of the participating groups, Industrial Advisory Board and Contactgroups. Final editing : Prof.dr.ir. G Ooms and Mrs. I Hoekstein of the JM Burgerscentrum.

Design and lay-out : I Hoekstein
Printed by : NIVO, Delft

PREFACE



Prof.dr.ir. G Lodewijks
Chairman of the JMBC Board



Prof.dr.ir. G Ooms
Scientific Director

As in preceding years this annual report of the J.M. Burgerscentrum provides an overview of the activities of our research school during last year (2013). The core of the report consists of the description of the research projects, carried out by the JMBC groups. In each report the relevant information (title, theme, staff involved, project aim, achievements, publications, funding source, application, etc.) is given. Also some research highlights are presented. It provides also general information about the research school, such as goals, organization, relation with industries and technological institutes. Moreover some autobiographical notes of Burgers are given.

In 2013 we received a positive final judgement by the ECOS (Accreditation Committee of the Royal Netherlands Academy of Sciences) about the re-accreditation of our research school. In this judgement the ECOS paid particular attention to two main aspects: (1) the educational – and supervision program and (2) the organisation of the research school. In the evaluation it is concluded that both aspects satisfy to a large degree the international quality norms. The ECOS wrote in its report that the educational program is of high quality. With respect to the quality and cohesion of the scientific mission the ECOS followed the positive conclusions and advice given in the SEP-evaluations of the JMBC groups. The ECOS mentioned that the JMBC has a strong link with industry, which is important for a practical application of the research. It is enthusiastic about the fact, that the PhD-students have no problem finding a job after finishing their study. Our research school has been accredited for the coming six years.

A meeting on numerical methods for multiphase flows was organized in the aula building of the TU-Delft between JMBC-groups active in this field and representatives from industries and technological institutes that deal with multiphase flow problems. There are several techniques available nowadays for the numerical modelling of multiphase flows and it is important that users in industries and institutes are aware which method is best for their problems. The idea of the meeting was twofold: (1) explain the practical problems to the JMBC-experts via presentations from representatives of industries and institutes, and (2) bring industries and institutes up-to-date about the numerical techniques via presentations of JMBC-experts. During the morning session there were presentations by representatives from industries and institutes. The emphasis of the morning session was on the problems that are encountered in industries and institutes when numerically solving multiphase flow problems. During lunch an inventory was made of the numerical problems as discussed during the morning session. During the afternoon session a number of professors of the JMBC gave presentations, during which they tried to answer to the problems as discussed by representatives of industries and institutes during the morning session and lunch session. Thereafter conclusions were drawn and a plan of action was made.

There was again a considerable interest for the annual event (Burgersdag) of the JMBC, which was held in Delft. The Burgersdag was opened by the rector of the TU-Delft. The Burgers Lecture given by prof. Henk Dijkstra of Utrecht University, was excellent. The presentations by the PhD-students in parallel sessions were interesting and well attended.

A number of newly appointed professors have started their participation in the J.M. Burgerscentrum: Michel Versluis, Jacco Snoeijer, Gerrit Kroesen and

David Smeulders.

The appointment of the current scientific director of the JMBC ends on 1 July 2014. On that date his successor will be appointed.

Due to the enthusiasm and the combined knowledge, skills and facilities of the participating research groups, the JMBC remains to be a very stimulating, multidisciplinary environment for advanced research in fluid mechanics and for the education of talented graduate and postgraduate students. The board and the management team of the JMBC highly value the large effort of the staff of the JMBC in reaching the goals of the research school.

Prof.dr.ir G. Lodewijks
Chairman of the JMBC-Board

Prof.dr.ir. G. Ooms
Scientific Director

CONTENTS



CONTENTS

ORGANISATION

| | |
|----|--|
| 13 | Introduction |
| 14 | Participating universities and groups |
| 16 | Industrial Board |
| 17 | Contactgroup “Multiphase Flow” |
| 17 | Contactgroup “Computational Fluid Dynamics (CFD)” |
| 17 | Contactgroup “Combustion” |
| 18 | Contactgroup “Lattice-Boltzmann techniques” |
| 19 | Contactgroup “Turbulence” |
| 19 | Contactgroup “Experimental Techniques” |
| 20 | Contactgroup “Biological Fluid Mechanics” |
| 21 | Contactgroup “Microfluidics” |
| 21 | Burgers Program for Fluid Dynamics at the University of Maryland |
| 23 | Introduction to autobiographical notes of Burgers composed in 1954 |

HIGHLIGHTS

| | |
|----|--|
| 41 | Simulations of turbulent compressible flow with little artificial dissipation <i>W Rozema (RUG/NLR), JC Kok (NLR), RWCP Verstappen (RUG), AEP Veldman (RUG)</i> |
| 43 | Acoustic droplet vaporization <i>O Shpak, D Lohse, M Versluis (UT)</i> |
| 45 | Non-invasive measurements in reactive granular flows <i>M van Sint Annaland, F Gallucci, I Roghair (TU/e)</i> |
| 47 | Added-mass effects and partitioned iterative solution methods <i>EH van Brummelen (TU/e)</i> |

RESEARCH

| | |
|----|---|
| 51 | Introduction |
| 51 | Description of the research themes |
| 51 | Review of progress in research projects |

TUD

| | |
|-----|---|
| 55 | Fluid Mechanics |
| 85 | Marine Technology |
| 89 | Dredging Engineering |
| 99 | Numerical Analysis |
| 113 | Mathematical Physics |
| 119 | Transport Phenomena |
| 147 | Product and Process Engineering |
| 161 | Nuclear Energy and Radiation Applications |
| 165 | Aerodynamics |
| 177 | Environmental Fluid Mechanics |
| 191 | Geoscience and Remote Sensing |

| | |
|---|-----|
| TUE | |
| Mesoscopic Transport Phenomena | 199 |
| Vortex Dynamics and Turbulence | 211 |
| Transport in Permeable Media | 235 |
| Elementary processes in gas discharges | 247 |
| Combustion Technology | 253 |
| Process Technology | 275 |
| Energy Technology | 283 |
| Multiscale Engineering Fluid Dynamics | 293 |
| Microsystems | 297 |
| Cardiovascular Biomechanics | 305 |
| Centre for Analysis, Scientific Computing and Applications (CASA) | 311 |
| Multiphase Reactors Group | 323 |
| UT | |
| Computational Biophysics | 349 |
| Physics of Fluids | 355 |
| Physics of Complex Fluids | 373 |
| Soft matter, Fluidics and Interfaces | 383 |
| Applied Analysis & Mathematical Physics (AAMP) | 389 |
| Mathematics of Computational Science | 391 |
| Multiscale Modeling and Simulation | 397 |
| Engineering Fluid Dynamics | 403 |
| Thermal Engineering | 425 |
| Multiscale Mechanics | 435 |
| Water Engineering and Management | 449 |
| RUG | |
| Computational Mechanics and Numerical Mathematics | 461 |
| WUR | |
| Experimental Zoology Group | 467 |
| UU | |
| Institute for Marine and Atmospheric Research Utrecht (IMAU) | 469 |
| Dynamical Oceanography at IMAU | 471 |
| WHO AND WHERE | |
| Participating groups and project leaders | 475 |
| JMBC Board of Directors | 478 |
| Management Team | 478 |
| Industrial Board | 478 |
| PhD students Contact Group | 479 |
| JM Burgerscentrum (The Netherlands) | 479 |
| Burgers Program for Fluid Dynamics (University of Maryland, USA) | 479 |

ORGANISATION



ORGANISATION

The JM Burgerscentrum (JMBC) is the Dutch research school for fluid mechanics. The Delft University of Technology is the coordinating university. The main goals of the JMBC are:

- ♦ Stimulation of co-operation of the participating groups with respect to their research efforts. It is the desire to be one of the leading institutes for fluid mechanics in the world.
- ♦ Organization of advanced courses for PhD-students. Researchers from industries and technological institutes also attend these courses.
- ♦ Co-operation with industries and technological institutes. The aim is to promote the use of up-to-date knowledge on fluid mechanics for solving practical problems.
- ♦ Strengthen the contacts between Dutch fluid mechanics research groups at universities and the international fluid mechanics community.

About 60 professors with their groups participate in the JMBC. These groups are located at the Delft University of Technology, Eindhoven University of Technology, University of Twente, the University of Groningen, Wageningen University and Utrecht University. They are from a number of disciplines; such as Civil Engineering; Mechanical Engineering; Maritime Technology; (Applied) Physics; Aerospace Engineering; Applied Mathematics and Chemical Technology. The professors with their senior staff form the council of project leaders, which meets regularly. There are about 300 PhD-students in the JMBC.

The JMBC has a scientific director who is responsible for the management of the research school; the JMBC secretary assists him. Three times per year he justifies his actions to the Board of the JMBC, and asks the Board for advice with respect to proposed new activities. He is also assisted by the Management Team, which consists of the local directors from the Delft University of Technology (also responsible for the groups at the University of Leiden), Eindhoven University of Technology (also responsible for the groups at the University of Wageningen and Utrecht University) and the University of Twente (also responsible for the groups at the University of Groningen).

The research projects carried out by the JMBC-groups have been ordered in a number of research themes. The reason for this ordering is to present in each theme a combination of projects which have coherence. The themes are:

- ♦ Complex dynamics of fluids
- ♦ Complex structures of fluids
- ♦ Mathematical and computational methods for fluid flow analysis.

The JM Burgerscentrum has many good contacts with industries and technological institutes in The Netherlands. For that reason there is an Industrial Board, in which Unilever, TataSteel, Philips, AKZO-Nobel, Teijin Aramid, Shell, DOW Benelux, ASML, DSM, Océ, NLR, NMI/VSL, TNO-Science and Industry, TNO-Defence and Safety, TNO-Oil - and Energy Industry, MARIN, Deltares, KEMA, ESTEC, ECN/NRG, FlowServe and Vortech participate. The Industrial Board meets regularly with the scientific director to discuss new activities of relevance to industries and technological institutes.

Each year (also in 2013) there are many scientific contacts with research groups in other countries. For that reason there are often external visitors to the JMBC groups. JMBC staff also regularly visits foreign fluid-mechanics groups, and presents their work at international conferences. The number of publications from JMBC staff in well-known scientific journals is considerable.

Together with Engineering Mechanics (the research school on solid mechanics) the JMBC forms the Centre for Fluid and Solid Mechanics. This Centre has been recognized as a centre of excellence in The Netherlands and has received significant funding by the Dutch Government for stimulating new research areas in fluid and solid mechanics.

The JMBC has attracted top-experts in different fields of fluid mechanics to the JMBC. These experts have been appointed as JMBC-professors or Centre-of-Excellence professor at the three Technological Universities and are financed by the Boards of the Technological Universities or by the Centre for Fluid and Solid Mechanics. They contribute considerably to the achievements of the research school. An important activity of the JMBC is the organisation of the annual meeting of the research school (Burgersdag). This year about 250 persons attended the meeting. The theme of the meeting was research by JMBC PhD-students.

OVERVIEW OF THE CONTRIBUTION OF THE PARTICIPATING GROUPS OF THE JMBC

| University and (sub)faculty | Project leaders | Scientific staff (fte) | Support staff (fte) | PhD students (fte) |
|----------------------------------|---|------------------------|---------------------|--------------------|
| TUD | | | | |
| Mechanical Engineering | J Westerweel, DJEM Roekaerts, RAWM Henkes, JCR Hunt, G Ooms, B Eckhardt | 4.4 | 2.0 | 19.2 |
| Maritime Engineering | BJ Boersma | 5.7 | 2.0 | 12.0 |
| | RHM Huijsmans, TJC van Terwisga | 1.6 | - | 8.0 |
| Applied Mathematics | C van Rhee | 1.0 | - | 4.0 |
| | C Vuik, P Wesseling, AWH Heemink | 6.8 | - | 10.4 |
| Chemical Engineering | CR Kleijn, RF Mudde, HEA van den Akker, S Sundaresan | 1.95 | 3.2 | 11.2 |
| | M Kreutzer | 2.1 | 0.5 | 6.0 |
| Radiation Science & Techn. | THJJ van der Hagen (M Rohde) | 2.6 | 2.0 | 1.6 |
| Aerospace Engineering | H Bijl, F Scarano, PG Bakker | 9.0 | 5.0 | 32.0 |
| Civil Eng. & Geosciences | GS Stelling, WSJ Uijtewaal | 6.5 | - | 11.2 |
| | HJJ Jonker, P Siebesma | 0.8 | 0.3 | 7.2 |
| TUE | | | | |
| Applied Physics | AA Darhuber, MEH van Dongen | 2.2 | 0.8 | 4.0 |
| | HJH Clercx, GJ van Heijst, F Toschi, BJ Geurts | 4.6 | 1.0 | 9.3 |
| | K Kopinga, OCG Adan | 1.2 | - | 7.2 |
| Mechanical Engineering | LPH de Goey (RJM Bastiaans), B Johansson | 1.9 | 5.0 | 14.4 |
| | JJH Brouwers | 2.0 | - | 4.0 |
| | DMJ Smeulders, AA van Steenhoven, HA Zondag | 2.1 | 1.8 | 10.0 |
| | JMJ den Toonder | 0.7 | - | 6.4 |
| | EH van Brummelen | 0.7 | - | 0.8 |
| Biomedical Engineering | FN van de Vosse | 0.2 | - | 3.2 |
| Mathematics and Computer Science | B Koren, WHA Schilders, F Toschi | 0.8 | - | 3.2 |
| | CJ van Duijn, MA Pelletier, IS Pop, JJM Slot | 2.4 | - | 3.2 |
| Chemical Eng. & Chemistry | JAM Kuipers, M van Sint Annaland | 2.0 | 1.8 | 10.8 |
| | GMW Kroesen | 0.2 | 1.2 | 6.0 |

| University and (sub)faculty | Project leaders | Scientific staff (fte) | Support staff (fte) | PhD students (fte) |
|-----------------------------|--|------------------------|---------------------|--------------------|
| UT | | | | |
| Applied Physics | WJ Briels | 2.4 | - | 5.6 |
| | D Lohse, D van der Meer, A Prosperetti, JF Dijkman L van Wijngaarden, R Verzicco F Mugele | 9.5 | - | 22.8 |
| Chemical Engineering | RGH Lammertink | 0.7 | 0.8 | 5.6 |
| Mathematical Sciences | EWC van Groesen | 0.5 | - | 3.0 |
| | JJW van der Vegt | 1.5 | - | 5.0 |
| | BJ Geurts, JGM Kuerten, HJH Clercx | 2.3 | - | 2.4 |
| Mechanical Engineering | HWM Hoeijmakers, A Hirschberg | 2.0 | 2.6 | 7.2 |
| | ThH van der Meer | 1.1 | 0.4 | 8.8 |
| | S Luding | 3.1 | - | 9.0 |
| Water Engineering & Manag. | SJM Hulscher | 4.0 | - | 6.0 |
| RUG | | | | |
| Mathematics | AEP Veldman | 1.9 | - | 5.6 |
| WUR | | | | |
| Experimental Zoology | JL van Leeuwen | 0.5 | - | 0.9 |
| UU | | | | |
| Physics and Astronomy | LRM Maas | 0.2 | - | 0.8 |
| | H Dijkstra | 0.3 | - | 0.8 |

The calculation of fte's is based on:

Professor 0,3 fte | Part-time professor 0.1 fte | Associated professor and assistant professor 0,4 fte | post-doc 1,0 fte |

Support Staff 1.0 | PhD-student 0,8 fte

OVERVIEW OF UNIVERSITY PARTICIPANTS

| University | Scientific staff (fte) | Support staff (fte) | PhD-students (fte) |
|------------|------------------------|---------------------|--------------------|
| TUD | 42.45 | 15.0 | 122.8 |
| TUE | 21.0 | 11.6 | 82.5 |
| UT | 30.2 | 5.8 | 85.4 |
| RUG | 1.9 | - | 5.6 |
| WUR | 0.5 | - | 0.9 |
| UU | 0.5 | - | 1.6 |
| Total | 96.55 | 32.4 | 298.8 |

INDUSTRIAL BOARD

It is a privilege to contribute a few words to the Annual Report of the J.M. Burgers Centre, the research school for fluid dynamics in The Netherlands. In the time I have been member of the Industrial Advisory Board of the J.M. Burgers Centre I have witnessed a continuous increase of the industrial participants, with presently Shell, Unilever, TataSteel, Philips, AKZO-Nobel, Teijin Aramid, and DOW. This illustrates the present position of the well recognised research school.

The interest of the Dutch Industry for the use of OpenFOAM was noted some years ago. The response from the assembled industries during the first sounding meetings underpinned a surprising interest in the initiative. The list of industries is:

Benelux, ASML, DSM , Océ , NLR, NMI/VSL, TNO-Science and Industry, TNO-Defence and Safety, TNO-Oil - and Energy Industry, MARIN, Deltares, KEMA, ESTEC, ECN/NRG and FlowServe.

The idea is that OpenFOAM is an ideal platform for knowledge transfer from Universities and institutions to the participating industries. To achieve this, the initiative group prepared an application of the OpenMIND programme for STW support. The supporting industries were convinced of the good application perspective, but the application was judgment as insufficient. Looking backward, all involved in the initiative remain very supportive. The number of collaborative industrially supported projects which use OpenFOAM continues to grow, which illustrates the continued support of industry. Note that the continued support of our scientific director Prof. Gijs Ooms and the support of Ilse Hoekstein-Philips within the Burgers Centre has been an essential contribution to the collaborations.

One example of a well recognised event is the Burgers Day where PhD's were demonstrating and sharing their developments. The sustained huge number of visitors of the Burgers Day illustrate that the community is living and developing well. I thank the Scientific Director of the Burgers Centre and the Office for leading this living community to the volume is has nowadays.

The present state of the economy in The Netherlands, and in Europe did not directly impact the collaborative projects. However, the Industrial Board will consider the possibility of new collaborations which might fit better in the present industrial climate.



Dr. RPJ Duursma
Tatasteel
Chairman of the Industrial Advisory
Board



Prof.dr.ir. AE Mynett
UNESCO-IHE
Chairman of the Industrial Advisory
Board



Prof.dr.ir. RAWM Henkes
Delft University of Technology



Dr.ir. NG Deen
Eindhoven University of Technology



Prof.dr.ir. AEP Veldman
University of Groningen



Prof.dr. DJEM Roekaerts
Delft University of Technology

CONTACTGROUP “MULTIPHASE FLOW”

The objective of the Contactgroup Multiphase Flow is to stimulate interaction and collaboration between researchers, developers, and users in the area of multiphase flow from universities, institutes and industries. This is done through organizing regular meetings (once or twice per year) aimed at getting to know each other's activities and to learn about developments and applications of multiphase flow technology. This will provide a good forum to identify the needs of the users and to bring to the attention new possibilities for applying multiphase flow research results. Industry, a research institute or a university in turn act as host of the meetings. The program consists of a series of lectures on a specific theme and a visit of some of the local multiphase flow facilities.

Examples of themes covered are: dynamic multiphase flows, multiphase flows with surface-active agents, multiphase flow measurements and innovation with multiphase flow. On 22nd May 2013 a one-day meeting was held at Tata Steel in IJmuiden. The theme of that day was “Multiphase Flow and Turbulence”. The day was jointly organized with the Contactgroup “Turbulence”.

CONTACTGROUP “COMPUTATIONAL FLUID DYNAMICS (CFD)”

The aim of the contactgroup “Computational Fluid Dynamics” is to exchange knowledge and experience in developing and applying CFD methods. Hereto, on 13 December 2013 a meeting was organized around simulation methods for flows with complex boundaries, such as free-surface flow and two-phase flow. A number of PhD students enthusiastically presented their research projects. The meeting was organized in cooperation with Deltares in Delft. A tour along some of their experimental facilities was included in the programme, which was attended by around 30 participants.

CONTACTGROUP “COMBUSTION”

The JMBC has groups active in combustion research at the universities of Delft, Eindhoven, Groningen, and Twente. The contactgroup combustion is an informal network between these groups. These groups also participate in the STW-platform ‘Clean and Efficient Combustion’ to enhance the mutual collaboration between the different groups and to interest more industrial parties for the fundamental research on combustion.

The annual COMBURA symposium was organized for the 12th time. It took place in Maastricht on October 9 and 10. This symposium is the major annual event in the Netherlands for exchange of information on combustion research and its applications. It is a joint initiative of the STW-platform, the Nederlandse Vlam Vereniging NVV (Dutch section of the International Flame Research Foundation IFRF) and the Dutch section of the Combustion Institute. The afternoon of the first day was devoted to the eight research projects within the STW program on Clean Combustion Concepts (CCC), all of which are executed by research groups of the JM Burgers Centre. At the symposium three keynote lectures were held, with topics ranging from operability of industrial power plants (Dick van der Vecht and Frederik Serne), via semi-industrial combustion research (Dr. Tomasz Klajny (IFRF)) to new developments in turbulent combustion modeling (Prof. Dr. Heinz Pitsch (RWTH Aachen)).

The J.M. Burgerscentrum Course on Combustion took place at Eindhoven University of Technology from October 29 until November 1. The program covered laminar and turbulent combustion, theory and experiments, fundamentals and applications. Lecturers were coming not only from the JMBC groups but also from abroad: Prof. Thomas Dreier (University Duisburg-Essen) gave a lecture about new developments in laser diagnostics in combustion and Dr. Roy Hermanns (Oel-Waerme Institute) gave a lecture about vaporization and liquid fuel combustion.

CONTACTGROUP “LATTICE-BOLTZMANN TECHNIQUES”

The JMBC contact group on “Lattice-Boltzmann techniques” was first established in 2002. The Lattice-Boltzmann schemes can be seen both as flexible and efficient solvers for macroscopic fluid equations or as particle-based simulation techniques which make close contact with the kinetic theory of gases. It is this last feature that allowed, in recent years, the partial disclosing of the huge potential of the method. The Lattice Boltzmann method has demonstrated great accuracy and performance in dealing with multiphase and multicomponent flows, from laminar to turbulent, in presence of simple or complex boundary conditions. The contact group promotes the organisation of educational and research events.



Prof.dr. F Toschi
Eindhoven University of Technology



Prof.dr.ir. BJ Boersma
Delft University of Technology



Dr.ir. WP Breugem
Delft University of Technology



Prof.dr.ir. J Westerweel
Delft University of Technology



Dr. M Versluis
University of Twente

CONTACTGROUP “TURBULENCE”

The contactgroup “Turbulence” organizes yearly meetings between researchers of the JM Burgerscentrum active in the field of turbulence with the aim to strengthen contact between them and to exchange results and experience. PhD students and other researchers are given the opportunity to present their results in an informal setting that promotes discussion. Researchers that are not affiliated to the JM Burgerscentrum are also welcome to participate in our meetings. If you want to be invited for our meetings, please send an email to Wim-Paul Breugem at w.p.breugem@tudelft.nl with subject “jmhc turbulence mailing list”.

Past meetings of our contactgroup were held in IJmuiden (a joint meeting with the contactgroup Multiphase Flow at Tata Steel in May 2013), Groningen (April 2012), Eindhoven (April 2011) and Delft (June 2010). The next meeting will presumably be held in May 2014. More information on our meetings is available at www.pe.tudelft.nl/~wim/jmhc_turb_contactgroup

CONTACTGROUP “EXPERIMENTAL TECHNIQUES”

The Contact Group Experimental Techniques forms a platform where experiments and experimental techniques can be discussed and evaluated. The main function of the contact group is to organize meetings in which the practice of experimenting can be discussed. An important contribution of the contact group is the organization of the JMBC course on Experimental Techniques in Fluid Mechanics. The course is very popular among the JMBC members as it gives a broad overview of advanced experimental techniques commonly used in fluid mechanics laboratories. The next course will be held 2-6 June 2014 at the University of Twente.

CONTACTGROUP “BIOLOGICAL FLUID MECHANICS”

More and more research is conducted at the interface of biology and fluid mechanics. This happens within many disciplines, from physiology (e.g. the interaction between blood flow and vessel walls) to aerodynamics (e.g. flapping flight). However, all deal with the interaction between fluids and a complex, changing geometry. One of the main challenges is to bridge the gaps between physics (esp. fluid mechanics) and medical and health sciences. To stimulate this relatively young field of research and bring together researchers, a new contact group was started in 2006. While the contactgroup is formally a part of the J.M. Burgerscentrum, the participation from researchers from non-affiliated universities, medical centers and institutes is encouraged. Recent activities include mini-symposia in Wageningen (Experimental Zoology Group) and Eindhoven.

The Bio-Fluid Mechanics course (March 2009: about 40 participants) was jointly supported by the JM Burgers Centre and the ERCOFTAC organization by advertising the course amongst their members, via the website and by some financial means. Topics included: a recap of basics of fluid mechanics, external flows (swimming and flying, interaction of plankton and turbulence), internal flows (microcirculation, hemodynamics in large arteries, flow in flexible tubes, respiratory system, etc.). Examples of relevant experimental techniques, as well as simulation techniques were discussed. A new course is scheduled for 2014.



Prof.dr.ir. F van de Vosse
Eindhoven University of Technology



Dr.ir. C Poelma
Delft University of Technology



Prof.dr. F Mugele
University of Twente



Prof.dr. J den Toonder
Philips Research
Eindhoven University of Technology



Prof.dr.ir. J Westerweel
Delft University of Technology



Prof.dr. JM Wallace
University of Maryland

CONTACT GROUP “MICROFLUIDICS”

The contact group “Microfluidics” was established in 2005. The purpose of the contact group is to bring together students and postdocs interested in fluid dynamic aspects of microfluidics and give them a forum for presenting their results and exchanging ideas. Topics of interest include wetting and capillarity-driven flows, two-phase flow, drop generation, emulsification, contact line dynamics, flow visualization and measurement techniques. During the 2012 spring meeting of the contact group on May 31st in Eindhoven, 10 PhD students presented their recent progress and discussed their results with colleagues from other groups of the Tu/e, TUD, and UT. The next meeting is planned for late spring in Delft and will be announced to all members of the contact group in due time. Students and researchers who are interested in the activities of the group are invited to contact the organizers of the contact group and have their name added to the mailing list. On April 15-19, members of the contact group organize the JMBC course “Capillarity-driven flows in microfluidics”, which will take place in De Lutte, close to Twente. Participants are invited to apply for the course as usual via the JMBC website.

BURGERS PROGRAM FOR FLUID DYNAMICS AT THE UNIVERSITY OF MARYLAND

Inspired by the intellectual heritage of Johannes M. Burgers, who had a second career at the University of Maryland (1955 - 1981) after his retirement at the Technical University of Delft as Professor of Aero and Hydrodynamics, the mission of the Burgers Program for Fluid Dynamics is to enhance the quality and international visibility of the research and educational programs in fluid dynamics and related areas at the University of Maryland in partnership with the J.M. Burgerscentrum (JMBC) in The Netherlands. Fluid dynamics in this context is viewed to include a broad range of dynamics, from nanoscales to geophysical scales, in simple and complex fluids. The establishment of the Burgers Program for Fluid Dynamics was celebrated with an inaugural symposium at the University of Maryland in November 2004. Gijs Ooms, Scientific Director of the JMBC gave a lecture on the life and legacy Burgers on this occasion. At the second Burgers Symposium in 2005, James Wallace gave a talk celebrating the contributions of Frans T. M. Nieuwstadt, recently deceased Director of the Laboratory for Aero and Hydrodynamics of the Technical University of Delft and a founder of the JMBC.

The interdisciplinary Burgers Program encompasses over 70 faculty members spread over 22 different units in the College of Computer, Mathematical and Natural Sciences and the A. James Clark School of Engineering. For detailed information go to <http://www.burgers.umd.edu/>.

Burgers visiting faculty and student exchanges

In 2003 the Burgers Program created a Burgers Visiting Professorship in fluid dynamics. We have been able to attract a number of distinguished professors from universities abroad to spend up to a year at the University of Maryland working with our faculty and their graduate students and post-doctoral fellows. The first (2004-2005) Burgers Visiting Professor was Bruno Eckhardt of the Phillips Universität in Marburg. In 2005-2006 our Burgers Associate Professors were Sasa Kenjeres of TU Delft and Serge Simoëns of the Ecole Centrale de Lyon. Since then, our Burgers Visiting Professors have been Jerry Westerweel of TU Delft for three months in 2007, Willem van de Water of the Eindhoven University of Technology for 2 months in 2008, W. van Saarloos of Leiden University for two weeks, also in 2008, W. J. Briels of Twente University for two months in 2010, Marie Farge of the Ecole Normale Supérieure, Paris for one month in 2011, Henk Dijkstra of Utrecht University for two months in 2012 and Ulrike Feudel of the University of Oldenburg for six months in 2013. In addition, quite a number of graduate students from JMBC have had visits of several months at Maryland with our faculty. Faculty from the University of Maryland are encouraged to spend a sabbatical at one of the Dutch Universities associated with JMBC. Kenneth Kiger, who was a speaker at the Burgersdag 2006, earlier had spent a sabbatical year with the JMBC research group in Delft.

Burgers lectureship

We have also initiated an annual Burgers Lecture which is given by a distinguished visitor who comes to the campus for several days or even weeks in November. This is always the keynote lecture at our annual Burgers Symposium, which takes place in the week before the annual Division of Fluid Dynamics meeting of the American Physical Society. In 2003 Frans Nieuwstadt, was our lecturer. Since then, Bruno Eckhardt, Charles Meneveau of Johns Hopkins University, Gijs Ooms, Detlef Lohse of Twente University, Wim van Saarloos, Kees Vuik of TU Delft, Wim Briels, Marie Farge, Henk Dijkstra and Ulrike Feudel have been our Burgers Lecturers.

Annual graduate student/post-doctoral fellow showcase symposium with Johns Hopkins University

In collaboration with the Center for Applied and Environmental Fluid Mechanics of Johns Hopkins University, the Burgers Program has put on an annual graduate student/post-doctoral fellow showcase symposium in the spring of each year, beginning in April, 2005. The venue for the symposium alternates between sites each year. After a keynote address by a faculty member from the visiting institution, students and research associates give short presentations on their research. Members of the fluid dynamics community from around the region are invited to attend the symposium with the hope that the presentations will interest these attendees and create employment opportunities for the presenters. Since 2012, faculty, graduate students and post-doctoral fellows at the George Washington University in Washington, D.C. have also participated in the symposium.

Tutorial summer school on fluid dynamics

This initiative was inaugurated in late May 2010, with plans to try to offer it every year. The level of instructions for these schools is aimed somewhat beyond that of a first graduate course in the subject area. The subject of the first School was Turbulence. Almost 40 graduate student and post-doc participants from the U.S. and other countries, including nine from JMBC, attended. Subsequently, successful Tutorial Schools on Granular Flows - From Simulations to Astrophysical Applications was held in June of 2011 and on Data Assimilation in Geoscience was held in June 2013. In June 2014, a School on Regional Climate Modeling will be held.

Fluid dynamics reviews seminars

This seminar series, which has continued for fifty years at the University of Maryland, has been incorporated into the Burgers Program. It is supported by the Minta Martin research fund. The format allows for faculty and their students and post-docs from the Burgers Program as well as for visitors to give presentations five or six times per semester. The seminar series has sponsored the visits of a long list of very distinguished speakers over the many years it has been a part of the campus' intellectual life.



Prof.dr. J.V Sengers
University of Maryland



Prof.dr.ir. G Ooms
JM Burgerscentrum

INTRODUCTION TO AUTOBIOGRAPHICAL NOTES OF BURGERS COMPOSED IN 1954

J.V. Sengers and G. Ooms

Johannes (Jan) M. Burgers was born in Arnhem in The Netherlands on January 13, 1895. His potential as an outstanding scholar was recognized early and he started to work as a Professor of “Aerodynamics, hydrodynamics, and their applications” in the Department of Mechanical Engineering, Shipbuilding Engineering, and Electrical Engineering of the Technical University in Delft in 1918, two months before he received his PhD in the Physical and Mathematical Sciences from the University of Leiden as a graduate student of Paul Ehrenfest. Jan Burgers became one of the prominent scholars in fluid mechanics during the first half of the 20th century. William F. Durand of Stanford University considered Jan Burgers as one of the “Big Four” in fluid mechanics at the time, the other three being Theodore von Kármán, Ludwig Prandtl, and Geoffrey I. Taylor. In 1955 Jan Burgers moved to the USA to become a Research Professor at the Institute for Fluid Dynamics and Applied Mathematics of the University of Maryland. When Burgers reached the mandatory retirement age of 70 in 1965, the University of Maryland took the exceptional step of enabling him to remain professionally active as a Research Professor on a part-time basis for many more years. He died on June 7, 1981. A considerable amount of information about Jan Burgers can be found in a volume edited by F.T.M. Nieuwstadt and J.A. Steketee [1]. This volume also contains biographical information.

The Burgers Archives contain two sets of extensive autobiographical notes written by J.M. Burgers in 1962 at the University of Maryland, one dealing with the period of his youth in Arnhem and one other dealing with his experiences as a student at the University in Leiden. We have published these two sets of autobiographical notes in 2007 on the occasion of 15th anniversary of the JM Burgers Centre [2].

Subsequently we have found another set of autobiographical notes, earlier written by Burgers in 1954. To understand the motivation behind these autobiographical notes, we need to return to the time that Burgers was a graduate student of Paul Ehrenfest [3, 4]. Ehrenfest, born in Vienna, had married the Ukrainian and Russian-educated Tatiana Afanasyeva. After working for some time in St Petersburg, where the couple became friends with the physicist Abram Joffe, Ehrenfest had been appointed as professor of theoretical physics in Leiden in 1912. However, Ehrenfest continued to keep close contacts with Russia. After the Bolsjevik revolution, Ehrenfest shared with some intellectuals at the time the hope that through socialism a new culture could be realized with a close harmony of science and society. This inspired some of the students of Ehrenfest, including Jan Burgers [5]. In 1918, the Communist Party of Holland (CPH) was formed and Burgers joined the group of intellectuals involved in this party. Around 1930 Burgers became disenchanted with the CPH because of the undemocratic Soviet influences which had penetrated the CPH and he formally resigned as a member of the CPH in 1933.

The contacts of Jan Burgers with the U.S. started in 1931, when he spent some time at the California Institute of Technology (Caltech), Pasadena, CA, upon the invitation of Durand. After World War II, Burgers was invited to visit the Naval Ordnance Laboratory in Maryland and Caltech in California in 1949. Subsequently, Burgers and his wife returned to the US for the entire

1950-1951 academic year, where Burgers became involved in many professional activities throughout the U.S.

Burgers had found his experiences in the U.S. very inspiring and he had favorably reacted to the possibility of moving to the U.S. , which eventually led to a formal invitation in 1951 for Burgers to become a research professor at the University of Maryland. Hence, on October 25, 1951 Jan Burgers and his second wife, Anna M. Burgers-Verhoeven, applied for a U.S. immigration visa at the American Consulate in Rotterdam. However, it was the McCarthy era with a virulent anti-communist climate in the U.S. Because of his past affiliation with the communist party in the Netherlands, Jan Burgers was informed that no immigration visa would be granted to him and his wife. This was a very serious setback leading to a lot of activity involving various colleagues and administrators trying to resolve the problem. Eventually, Burgers was invited to come for an interview at the American Consulate in Rotterdam in early February 1954 to discuss the visa problem. He was told that any reconsideration of his visa application would require that he prepare a detailed report explaining his political activities and what he had done opposing communism. In response to this interview, Jan Burgers prepared a statement in March 1954 concerning the personal development of his political opinions, which was submitted to the American Consulate.

While the document was prepared by Burgers in support of his U.S. visa application, it is a fascinating historic document elucidating the evolution of his ideas about science and society and his personal struggle to reconcile these two aspects in his personal life. It also provides insight in the cultural atmosphere of the first half of the 20th century. Excerpts from this document can be found in the volume of Nieuwstadt and Steketee [1]. As mentioned earlier, we published some autobiographical notes of Burgers in 2007 on the occasion of the 15th anniversary of the JM Burgers Centre (JMBC). The period 2013-2014, covered in the present annual report of JMBC, coincides with the 10th anniversary of the Burgers Program at the University of Maryland, established in 2003 in close coordination with JMBC. Since the autobiographical notes of 1954 are intimately related to the desire of Jan Burgers to embark on a second career in the U.S., this would seem to be a proper occasion to make these autobiographical notes available in their entirety. The notes below are a transcript of the original ones found in the archives with some minor editorial adjustments. We believe that these notes are of interest to those who admire Jan Burgers as a scholar and as a person and who appreciate his scientific heritage in The Netherlands and in the U.S.

J.M. BURGERS

Statement concerning the development of my political opinions (March 1954)

From my parental home I have received the urge to form an independent judgment and to think freely. I also learned the utmost importance of moral and intellectual honesty, and of faithfulness. Together with that, I was educated in the conviction that one must strive towards enlightenment for everybody and towards providing every man and woman with the possibility of living without poverty and fear. I learned to consider peoples of other nations as being just as valuable and important as those of my own country.

Moreover, from my parental home I received the desire to inquire and to understand. My father had great abilities



expounding popular science; his wide interests, which my mother shared as far as she could, were communicated to my brother and me. In this way we were introduced into the elements of physics, astronomy, geology and biology, and at an early date we were shown the wonders revealed by the microscope. Gradually we took over from our mother the task of assisting father with his popular lectures and demonstrations, and we helped him when he was collecting or arranging material for these lectures. The secondary school, which we visited in our native city Arnhem, widened my interests towards ancient history and geography. Nevertheless, since I was good at mathematics and physics, the latter subjects became preponderant and determined my further career. My brother took to physical chemistry.

In 1914, when I was nineteen, I went to the University of Leiden to study mathematics and physics. I listened in particular to lectures of Lorentz, Kamerlingh Onnes and Ehrenfest. Among these three, it was Ehrenfest (who gave the main course in theoretical physics) who has had the greatest influence on me, through his sincere and complete friendship and through his powerful analytic mind, which deepened in me the desire for inquiry and understanding without limit and without fear. In later years I understood that I possessed something which Ehrenfest missed: a conviction of the meaning of life, a faith in the sense of all things around us, which I owe to my father. This has protected me and has helped me over difficulties that Ehrenfest has not been able to conquer.

My student years coincided with the war of 1914-1918 in Europe, which had cruelly shattered the ideals we had cherished in my parental home. The development of the war brought atrocities and the beginnings of suppressions of freedom, which later on have become more and more severe in several parts of the world. Under these circumstances it is not strange that young people, like me, were deeply struck by the fact that in the beginning of 1917 a regime of oppression was overthrown in Russia. We were even more impressed by the first words of peace that were spoken in November of that same year by the group of men who had then come to power in that country. In comparison with the stagnant ideas of the other political groups, it looked that under the conditions then existing, the program of the men who tried to find some solution out of the terrible plight in which the Russian people found itself, was the best approximation available to the ideals of freedom from want and freedom from oppression, which always stood before me. I use the word "approximation" intentionally: as a scientist I am convinced that our thoughts cannot be otherwise than approximations to a truth which itself is beyond us; one pursues an approximation so long till one is prepared to discard it when it is superseded by a better one.

Under these circumstances I felt induced to take up contact with a group of "left-wing" people in Holland, who had broken away from the social-democratic party already in 1909 and who looked with great hopes to what was now being attempted in Russia. The members of this group were mainly intellectual people and some poets; there were amongst them at that time comparatively few people from what is called the "working class". Several of them wrote essays on political theory. They did not intend to "start a revolution"; their theory was (and I think it goes back to Marx's own ideas) that a revolution may occur in a country, when economic or other difficulties have risen to such a point that the existing government is unable to find a solution; if under such circumstances great masses of people would come into motion, a revolution might be the result, and in view of that it would be useful to contemplate whether some other solution, some other economic and political system could help.

A book that had appeared in 1918 and had made a certain impression on me, was by the late Henriëtte Roland Holst, who is honored (still at the present time) as the greatest female poet in Holland of our era, on "Revolutionary Mass Action." It attempted to demonstrate that in times of crisis the masses could be trusted to have the proper feeling for what would be the right thing to do, and it gave a historical account of many situations where this had happened. I hoped that this doctrine would be true, fearing that ordinary education works too slowly and may not reach its purpose when it is not stimulated from time to time by some great shock. Later I have realized that when large masses of people come into motion, too many stupid and crippled souls penetrate into the leading groups, the consequences of which have appeared, very cruelly, in Russia and in Germany, as well as in many other regions.

To come back to the group of "left-wing" people I have mentioned, all of them had started from democratic principles and though they often quarreled frightfully amongst themselves, they still had respect for each other's personality. The relations existing in their organization were quite different from what has developed afterwards; there was no party organization in the later sense of the word. In 1918 they had started to call themselves "Communist Party of Holland" (CPH), but at that time and even for many subsequent years they did in no way resemble the organization that is presently known as communist party. My belief at the time, that this group was a bearer of ideals directed at promoting well-being and happiness for the greatest number of people, more adequate than any other then existing political group, was strengthened by the state of conservatism and reaction which prevailed in many countries of Europe in the years immediately following 1918.

The complete failure of the social-democrats of that time to give a clear analysis of the crisis that was tearing Europe apart, had caused a bitter disappointment.

The League of Nations, which had been created at the end of the war, was loaded with so many internal quarrels and such weaknesses, that it did not look like a promising instrument. It was only several years later that it began to embody certain important ideals. An organization for international scientific cooperation, created in 1918-1919, suffered under rules which locked out scientists from Germany and Austria. It was only in 1928 and finally in 1931 that these rules were changed and that a better climate for cooperation appeared. Therefore, my own involvement in the field of international scientific cooperation started in an independent way, to which I shall come back later.

I have mentioned this to explain how uninspiring the outlook was in the years immediately following 1918. What was going on in Russia at that time seemed to be the only glimmer of light. It is difficult at present to form a proper picture of that period; so much of our outlook has changed since then and it will be more difficult for an American, in particular for the middle and younger generations, for whom problems and conditions were so completely different.

I state again, and this is of importance when one attempts to form a judgment about those times, that in the so-called CPH of these years (from 1918 into the nineteen-thirties), there was no oath of allegiance, no promise which bound members, no party documents giving any rights or putting one under certain obligations, no registration numbers, no cells, no secrecy. Holland was a slow country in several respects and those who sympathized with the communist ideas were imbued with democratic convictions and did not like to be bound hands and feet. The persons whom I met personally were older people, schooled in the days before 1914 and keen on open discussion. The group in Delft was not important and was very small, a few people from the working class, a few from offices, a schoolteacher, all of whom were democratic by nature. My interest was theoretical, directed at understanding and observing, in the belief that insight in communist opinion would provide understanding what happened in history.

I have never taken part in any action. Never did I take side in open discussions, whether at meetings or in writing; nor did I write any essays. I kept myself in the background, as an observer, and I have always kept complete personal independence. I have never mixed up anything of my political interests with my university work. The rules concerning the adherence to certain political parties valid for civil servants, did not apply to university professors. It was once pointed out to me that I should not make any political propaganda among students: I never attempted nor intended to do so. I did not start any discussion group, nor did I attempt to influence any student privately. I am not a propagandist for a subject which cannot be stated in mathematical formulas. On the whole I had little contact with students beyond my lectures during the first years of my professorship; and I was not inclined to expound to other people political views of which I felt the limitations and uncertainties myself.

In all those years, just as later, I have done all my work, in Holland and elsewhere, whether scientific, educational or administrative, honestly, loyally and carefully, as bound by my conscience and by my oath to my own government, and to the best of my abilities, without ever suffering myself to be led astray by any subversive doctrine or thought. I have never broken any trust that was placed in me, never given out any information to people for whom it was not intended. I have never accepted any rule of conduct from communists. I was trusted, therefore, by all my university colleagues and I took my part in the usual administrative work. Although many of my colleagues knew of my political views, my opinions were appreciated in all university matters. I have been secretary of the Department of Mechanical Engineering and Shipbuilding from 1921 to 1924, and chairman from 1929 to 1931.

I have never suffered myself to be blinded by a tenacious keeping to beliefs. I was interested in Marx's views on history and on economic development, but I found that, whereas some of his original ideas are highly illuminating, there was much in the development of so-called historic materialism, which I could not accept at face value. I began to observe errors of judgment in the people who professed communist ideas, and my sympathy with and my faith in communists decreased in the measure by which Russian influence began to show itself in the party in Holland and became a threat to independent thinking (the circumstance that more hopeful signs were making their appearance in other quarters also contributed to my change of attitude). In the communist party in Holland people whom I had respected for their judgment, were pushed out. I saw that tendencies developed towards doing away with an independent attitude. I remember having had a long discussion with somebody, who professed that loyalty to the party should go above all, above one's independent judgment, above honesty to other people, but I could not convince him of my entirely different point of view. I also remember that once I was asked what I would do if a revolution would break out. My reply was: "first wait and see what is happening, in order to understand something about it." This was considered quite insufficient: I should have said that I would come immediately to the party and follow its orders, which I refused. I began to distrust the soundness of the judgment of people who were directing communist policy, and I was extremely shocked by the fact that the communist party in Germany in the beginning

of 1933 directed its members to vote for Hitler and against the democratic groups, thinking that once Hitler would come to power, the communists would be able to take over within a few months. For a party that professed to have an almost perfect organization for obtaining information about workers' movements in all countries, such an error of judgment proved that it was blind on essential points. By doing so it has co-operated with the occurrence of the worst calamity that has befallen Europe in this century. In 1932, in a leading German communist periodical on "Marxism" I found a series of articles on the meaning of Marx's work, which utterly disgusted me by the way in which every author repeated the same slogans, without ever bringing a single original thought. It demonstrated the low level of thinking which official teachers of Marxism had adopted.

The result of all this, in addition to the increasing pressure of my scientific work, was that I ceased going to meetings already before 1930; it may well have been even some years earlier. Some personal bonds of friendship with a few of the older people still held me for a time, until I formally resigned in September 1933. A translation of my letter of resignation, dated 22 September 1933, is attached as an Appendix.

I did not undertake any open action against the communist party after my resignation; there was no reason for it and I have always been an enemy of advertising myself. I have never allowed party people to use my name for any purpose during my membership of the CPH; I did not want to have my name be associated with any opposition action. Neither would this have been in the interest of my University; such things would have been thoroughly disliked. I have not been a conspirator and nobody has thought that I ever would be one. On the other hand, I have not been treated badly by the party members; many of them had already observed the change in my attitude for a long time; they respected me and let me go without difficulties. Many of them still were democratically minded and could accept a personal conviction. Also, there were no improper activities in the party which might have required exposure. Yearly conventions were still open to the public, and the aim was to spread a system of political ideas, not to engage in secret conspiracy. It was not a communist party in the sense as is currently understood. There were many non-communist persons at that time who believed, as I did, that as one of the possible forms of political opinion the CPH could be useful. As for myself, I had already seen that for any attempt to help solve problems of human society, I would have to go quite a different way, to which I shall return below.

The party had ceased for me to provide a satisfactory background for ideals and for an understanding of what was moving the world. It had become barren for me and it is not in my nature to fight what is dead for me. Hence, I could leave it without scars in my conscience. I had no internal difficulties or doubts about doing this, which sometimes can hinder people greatly. Nobody had ever attempted to ask from me any dishonest thing; that did not happen among the people whom I have known. I was certain about myself and did not need to defend finding myself back again. I have not been so naïve as several people who contributed to the book "The God that failed", most of whom became communists when I had already turned away and had directed my thoughts in a different direction. I have not been upset in any way as some of them have been.

American citizens, judging from present day affairs, cannot form a picture of what existed in Holland in the years before 1933. The people who had established the communist party in Holland in that period, did so because they believed to have a vision of an ideal for the entire world; they also believed that Russia was on its way to realize much of it; but they never considered themselves to be just fighters on behalf of the U.S.S.R. and they fought against the penetration of Russian methods into the party organization. Later on, other views may have prevailed, but it was not so in my time, and it is not logically correct to put the group, which I have known, into the same category as the people who believe in the present Russian brand of communism.

A point which I want to stress is that I have taken great care that my children would not be inoculated with any communist doctrine which would be difficult for them to get rid of later. At home we always have discussed freely and with an open mind, giving attention to the various aspects of every problem. In 1933 my children (they are from my first marriage) were still young. When they grew up and became interested in what was happening around them, I have done my best to give them a clear allround view and I have expressed to them my distrust of communist tactics or opinion, in those cases where any piece of news opened an opportunity for discussion.

In later years my older daughter has turned to a more religious attitude of mind than I have myself. She is now a hospital nurse. My son has studied law. He was in Netherlands military service from 1947-1950; two years of this were spent in Indonesia, where he was not in the fighting forces, but worked at the court-martial in Batavia. In 1950 he was entrusted with the direction of the judge-advocate's office. At present he has a position at the Ministry of Foreign Affairs in The Hague. My younger daughter is studying medicine in Amsterdam, and she has the same openness of mind and the same fearlessness we all have, which was present in my father's home and in that of my first wife, and which is fully shared by my present wife.

In the meantime I had taken up work directed to furthering international cooperation in science. Later I have been occupied several times with the organization of research into problems connected with the relations between science and society. This work was aimed at promoting an attitude of mind quite different from that advocated by the communist party. I therefore think it appropriate to give some details about that work, the more so as it belongs to the circumstances which have shaped my mind. By the way, it were my international scientific relations which led to some contacts with Russia (these had not come through party connections) and to a close contact with the U.S.A.

I had been internationally minded from the start; to be otherwise is not possible in science. As a student in Leiden, I had worked with Professor Ehrenfest and in 1916 I succeeded in proving a theorem referring to an earlier form of quantum mechanics, which was of importance for Ehrenfest's work. Ehrenfest then brought me into correspondence with physicists outside Holland; among these was Dr. P.S. Epstein, who at the time worked in München (since 1922 he is professor of theoretical physics at the California Institute of Technology). Ehrenfest also introduced me to Einstein, when the latter visited Leiden in 1916.

In 1918 I was appointed as full professor of aero- and hydrodynamics at the Technical University of Delft, a position which I still hold at present. The appointment came a few months before I had obtained my doctor's degree at the University of Leiden; I was then 23. The professorship position that was entrusted to me was a completely new one in Holland; I do not even know whether at that time there were similar ones elsewhere. I had to create the subject and its method of teaching and I also had to create a (although modest) laboratory. In passing I mention that aeronautical research as required by industry and by the military was entrusted to a newly created Government Research Institute (founded in April 1918) with which I always have had strong personal and scientific relations. In 1937 I was appointed as a member of its scientific advisory committee.

In 1921 I became acquainted with Dr. Th. von Kármán, then professor of mechanics and aerodynamics in Aachen; this was the beginning of a lifelong friendship, by which I feel greatly honored and which did not change when Dr. von Kármán in 1930 went to the California Institute of Technology. It still lasts until the present time. Dr. von Kármán was then working on subjects of boundary layer friction and turbulence; in 1923 and 1924, by making use of a special type of apparatus, my assistant and I succeeded to do some fundamental research in my laboratory at Delft, which confirmed Dr. von Kármán's theories.

Dr. von Kármán also invited me to take part in the first international conference on Hydro- and Aerodynamics in Innsbruck in 1922. The next year Dr. von Kármán visited me and proposed that I should try to organize an International Congress on Applied Mechanics at our University in Delft. I consulted my colleague Professor C.B. Biezeno. Both of us felt greatly attracted towards the idea; we started working on this project and the Congress, which took place 22-26 April 1924, was a great success; scientists came from 19 countries, including U.S.A. (Dr. J.C. Hunsaker), U.S.S.R., Spain, Turkey and Egypt. Professor Biezeno was chairman and I was secretary; after the Congress we were editors of the Proceedings. We had invited a number of scientists from various countries to form a "sponsoring committee"; this committee became a permanent body which decided to arrange regularly for such international congresses. Since then they have been held in 1926 (Zürich), 1930 (Stockholm), 1934 (Cambridge, England), 1938 (Cambridge, MA, U.S.A), 1946 (Paris), 1948 (London), 1952 (Istanbul); the next congress will be held in Brussels in 1956. I have always remained a member of the International Congress Committee and have taken part in its discussions and decisions.

We did this independently of the then existing "International Research Council", the organization which I have alluded to earlier and which at that time suffered under rules barring the Germans and Austrians. We found sufficient support among our scientific colleagues to continue in our way without difficulties.

In 1928 the International Research Council was replaced by a new body, the "International Council of Scientific Unions", which could accept scientists from all countries. My colleagues in applied mechanics, in Holland, Great Britain and in the U.S.A, thought it wiser to remain independent with our international congresses. However, after World War II, at the VIth International Congress of Applied Mechanics in Paris, I proposed that we should change our attitude and form an "International Union of Theoretical and Applied Mechanics", which could ask admission to the International Council. This proposal was accepted and I was appointed secretary of the new International Union. The International Council accepted our Union as a member in 1947. I held the position of secretary until 1952. When I stepped down to get more free time for purely scientific work, I could then feel certain that the Union was well under way and leave the secretarial work to my successor, Professor F. H. van den Dungen in Brussels.

During my time as secretary I came into contact with UNESCO, which helped the Unions with financial grants. Together with Professor J. H. Oort in Leiden, representing the International Astronomical Union, we have initiated two "inter-Union" symposia on the gas dynamics of the interstellar clouds, one in Paris in 1949, and the other one at Cambridge, England in 1953. For each of these symposia UNESCO gave a grant of \$6000 for the two Unions together, to enable paying travel expenses for a selected group of invited scientists from European countries and from the U.S.A (naturally, most of the money had to go to the latter country because of the larger distance). Through the recommendation of Dr. von Kármán, the Proceedings of the first meeting (the editorial work was done by me in cooperation with Professor van de Hulst in Leiden) have been printed for us free of charge by the Central Air Documents Office of the U.S Army-Navy-Air Force in Dayton, OH, in view of the importance of the results for the U.S.A. Another "inter-Union" symposium, for which I also had taken the initiative, was held in 1950 at Hershey, PA through cooperation of the International Union of Geodesy and Geophysics and the International Union of Theoretical and Applied Mechanics, the subject being "Plastic Flow and Deformation within the Earth", while Dr. L. H. Adams of the Geophysical Laboratory, Carnegie Institute of Washington, acted as chairman. Again UNESCO gave a grant of \$6000 for the two Unions together.

I pass over some other international bodies of which I have been secretary and where my main task was to coordinate the work.

In 1929, when Dr. von Kármán was still in Aachen, Dr. W. F. Durand from Stanford University in California came over to invite European scientists to cooperate in the preparation of a standard work on aerodynamics, which he was editing under a grant from the Guggenheim Fund for the Promotion of Aeronautics.. Dr. Durand considered Dr. von Kármán, Professor Prandtl in Göttingen, Professor Taylor in Cambridge, England, and me to represent the "big four" in aerodynamics at that time; and he asked von Kármán and me to prepare one of the volumes. For this purpose Dr. Durand invited me to come to Stanford University in the beginning of 1931. I was in California for four months (including a stay of three weeks at the California Institute of Technology). This was my first visit to the U.S.A.

I now come to a discussion of my contacts with Russia. As mentioned earlier, they were of a scientific nature. Apart from that I have been no more than a visitor and a friend of several scientists.

At the first International Congress of Applied Mechanics in Delft in 1924, three Russian scientists attended, among them Professor A. F. Joffe (who was then one of the great masters in physics and who had done fundamental work on the properties of crystals, on which subject he gave a series of lectures some years later, in 1927, at the University of California in Berkeley, CA.) and Professor Friedmann, who brought a pioneering paper on turbulence. Friedmann died in Leningrad in 1925, and when in the fall of that year Joffe visited Holland again, he asked me whether I would be willing to become Friedmann's successor. I felt inclined to consider the proposal and in 1926 I visited Leningrad and Moscow for about six weeks, to see what was possible. It proved to be impossible for me; the conditions were too uncertain and moreover, I had to consider the state of health of my wife, for whom the difficulties of living in Russia would have been too great.

In 1929 and in 1930 I was invited to give a series of lectures on hydrodynamics in Moscow and in Leningrad. On both occasions I met many persons and I saw again several of those whom I had seen in 1926. Without exception they were persons of my class: scientists, professors, students; they were nice and friendly and hospitable to the utmost as the not very rich conditions of their country permitted. I spoke some Russian, sufficient for my lectures and for personal conversation; I could find my way alone and did not need a guide, and I visited many of my friends in their homes.

There still followed an invitation from the Central Aero-Hydrodynamic Institute in Moscow in 1936. I visited Russia in the summer, at a time when there were many American and other tourists, and I made a short trip to the Northern Caucasus. I did not stay, however, to give lectures as originally intended, since I received an invitation for a scientific conference at Edinburgh, Scotland, in which I had to take part. This obliged me to go back before the school season started.

Moreover, some things had given me an unpleasant feeling about the conditions in Russia. We had heard in Holland about convict labor, and in Moscow I was told in a local train that the new canals in the country around that city had been made by convicts. Of course, one cannot say anything about convict labor when one does not know the conditions, and about these we did not speak. However, there was more. The great physiologist Pavlov had died and the semi-popular Russian journal "Science and Life" published an issue in which, in the name of the Russian Academy of Sciences, various scientists expressed their admiration for Pavlov's work. As far as I could read the articles, they were disappointing: almost everyone stated that Pavlov had been such a good Marxist, but there was no real explanation of the meaning of Pavlov's work, no precise description of the experiments and their results, which would enable the reader to form a judgment for himself.

When I returned from the trip to the Caucasus, the first one of the well-known trials had just started. Together with one of my fellow passengers I read the newspaper report. I told him that I could not understand how a communist could have debased himself so far as to seek allegiance with Nazi-people and with capitalists in Germany. My fellow passenger, who made a very honest impression, told me that he could not understand it either. In Moscow I observed that every journal, including weekly periodicals, published exactly the same report; there was no individual reporting as we know in our countries. Then I read a story in the *Izvestia*, entitled "Treason amidst our own ranks", in which it was told that in a factory in Leningrad a young man worked whose father was among the accused (no sentence had been pronounced as yet), and it was decried as intolerable that the young man should be allowed to stay there. A meeting of the workers had been called to consider this and to require that he be fired. No mention was made of any bad deed or bad move the young man had made; as the worst item it was mentioned that he had been active in a youth organization. In the *Izvestia* of the next day there appeared a report on a workers' meeting at another factory: acting upon what had been reported about the previous meeting, the workers of the second factory expressed their indignation against the same young man and asked that he be chased from the ranks of faithful people. It was all too clear that this case of "guilt by association" was staged.

I then heard some things about trials in Russian prisons (not such things as have been told later or have been guessed from what the official reports of trials would make believe us), but still sufficiently impressive for me. It was about a man who had been before the court on a certain night and was told that he has forfeited the right to live and he knows that within a few minutes he will be sent out into the corridor where he will be shot immediately. In this state of nervous tension, the man may be offered a cigarette by the acting judge and this may lead to renewed questioning. The examination then perhaps may end with his being sent out through another door, back to his cell. This was in 1936; I do not know what has happened since then, but I am afraid that things have become worse. I could, of course, not speak in public about these matters, which would have endangered those from whom I had heard them. But I have mentioned them often in private conversation.

I also had observed the stubbornness of an official, whom I had to ask something about my passport, but on the other hand I still must record the helpful way in which another official, in a similar position but in another city, gave me an extension of my visa when it was nearly ended and made things easy for me.

Towards the end of 1936 it was told in Europe that it was better not to write to Russian colleagues any more, for fear that they might suffer from it in their own country. The consequence was that I lost all contact with the people whom I had known.

Shortly thereafter, it became known in Holland that several Dutch people, who in the years before had emigrated to the U.S.S.R. and who had given all their energy to their new country, had disappeared. It was impossible to obtain any information about them.

I repeat that the people with whom I had made acquaintance on my travels in the U.S.S.R. were scientists, university people. Of them I have the best recollections: they were friendly and sympathetic. I would say "just like Americans", but scientists are apt to form a brotherhood all over the world. I could trust them and I was trusted by them; of that I have proof. I have never had any contact with party members or with their organizations in the U.S.S.R. I was afraid that party people would make use of my presence for propaganda purposes, something I most heartily disliked and still dislike; I did not want being driven into a false position. I also knew that those scientists, like Joffe and some others, who had hoped that I would come to their country to work with them, in no way wanted me to be involved in party politics. They were men who loved science and loved mankind; they accepted their government for what it gave to them in the form of possibilities for research, they had hope in its future, but they were no party politicians. I know that one of my colleagues took care to keep Russian newspaper men away from me; he also told me that already at that time there were factions fighting each other to death. I have never been employed by the Russian government or by a Russian firm, neither directly, nor as a consultant.

I have not been so naïve as the French writer André Gide, who was a member of a delegation of artists much honored in Moscow (I believe it was also in the summer of 1936). Then Gide made a trip to the Caucasus, he wanted to send a telegram to Stalin to express his gratitude and he was upset when he was told that he should use the prescribed formulas for praising Stalin. Any man who used his brains should know that when one is honored as a special guest, one must pay for it in the form of some official statement of admiration. I have carefully kept away from these things and, therefore, I did not need to write a book "Retour de l'U.R.S.S." as Gide did, in which he gave some criticism along with his praise of the country (for which criticism he then was promptly decried by all communist papers in Western Europe).

As I mentioned, I spoke Russian sufficiently to make myself understood, and I could move freely through the streets, buy what I desired and travel in trains without the need of a guide. I have stayed with people at home and partook in their life.

My trip to the Caucasus was arranged by a friend who belonged to the Scientists' Club in Moscow and who gave me an introduction to a tourists' camp; I travelled alone, talked with my fellow passengers, shared their troubles when a truck in which we were transported broke down at night, or when on the road back heavy rains threatened to flood the road and to throw our bus into the river.

Then the second war came: the Russian-German pact and the partition of Poland, the forceful removal of the entire populations from the Baltic countries to Siberia, the attack upon Finland, etc. This showed us how much things had changed with the Russian government and with the party on which it bases itself. I have read later about German communists, who years before had come to the Soviet republic to escape from the Nazis, but who in 1940 were turned over by the Russian government to the Nazi police. What had become of the ideals for a new era of human freedom, which had been upheld before us some twenty years ago?

When in the second part of the last war the Russian armies were able to expel the Germans from their country, we all were very glad in Holland: it meant the turn of a tide which had enveloped us. The successes of the Russian armies were followed with much enthusiasm and we hoped at the same time for a better state of affairs in Russia herself, which would bring greater freedom to the Russian people and make possible a genuine contact between them and the Western nations. It is not necessary to stress that our hopes have failed in this respect.

I will now mention some points concerning the development of my world picture to make clear how far I have gone away from crude Marxist ideas.

I have already mentioned that about 1930 there were several developments which gave much more hope than in 1919 and 1920. The League of Nations proved to stand for some good things and I was impressed by the report the League had prepared on the Japanese aggression in China in 1932; I read this report with much interest and I saw that it was written without concealing any of the facts. Another feature was the address read by General J. C. Smuts from South Africa as president of the Centenary Meeting of the British Association in London, in 1931, on "The scientific world picture of today" in which he spoke the following words (which for many people have become a guiding thought):

"One of the greatest tasks before the human race will be to link up science with ethical values, and thus to remove grave dangers threatening our future. A serious lag has already developed between our rapid scientific advance and our stationary ethical development, a lag which has already found expression in the greatest tragedy of history. Science must itself help to close this dangerous gap in our advance, which threatens the disruption of our civilization and the decay of our species. Its final and perhaps most difficult task may be found just here. Science may be destined to become the most effective drive towards ethical values, and in that way to render it's most priceless human service. In saying this, I am going beyond the scope of science as presently understood, but the conception of science itself is bound to be affected by its eventual integration with the other great values."

A similar spirit was expressed in many books by the British author H. G. Wells, of whom I had read the "Outline of History" and the "Work, Wealth and Happiness of Mankind" and several others. Wells always gave evidence of flashes of deep insight; he had a peculiar form of expressing in a single sentence, by an apt choice of words, ideas which help one to arrive at fresh views on matters that for long times had been loaded with tradition. One of his observations was that it is now becoming inadequate to picture the struggles of mankind in terms of a contest between "haves" and "have-nots" as a "class war", as the Marxists did: far more, it is now becoming a struggle between people who have insight and look into the future, and people who are restricted in their outlook, being afraid of losing what made life appear secure for them.

I also became more aware of the meaning of what usually are called spiritual matters. I left behind me the simple concept of materialism, in the sense that all what happens in the universe and in man's soul might be explained uniquely and completely on the principles and results which we deduce from physics and mechanics. I recognized the limitations of scientific reasoning on the basis of causal and statistical laws (which, of course, does in no way decrease my love for science and my admiration for the insight it provides).

All this pointed to the need of a far more fundamental understanding than the political theories of the communist creed provided. It was not a domain which could lead to easy discussion, the more so as my way of expressing these matters on the whole is rather abstract. I cannot popularize my thoughts on these problems, since I am constantly seeking for the most adequate words. But on many occasions I came to express parts of my views in private letters and in discussions with some of my physicist friends.

If I try to formulate what I consider as the purpose of human life, I cannot say otherwise than that it is to strive continually after truth; to be continually aware of the task God has put upon us in giving us powers for understanding in forms which others can share with us.

I have used the word "God" not to express a belief in a personal Father, on whose will the world depends, but to account for the consciousness of an urge in us, which I believe to be connected with something that is active in the whole universe. I am also convinced that every expression we give to a truth that we have experienced, be it in human relations, in science, in artistic expression, or in religion, needs continuous rethinking, reformulation and re-interpretation. No final expression can be given once and for all.

My political views derive from this conviction. The best society is one which gives the greatest possibilities and inducements to search for truth and to its expression in manifold ways. Freedom is necessary for this: freedom of thinking and freedom of investigation, and in no way less freedom of expression. The only limits to this freedom are to be found in the help one must give to others; a form of expression that would do serious harm to others, does not serve truth but is a corruption of it.

In our present time not states, nor parties, but individuals and small, freely cooperating groups can make the greatest advances in this respect. And the greatest stimulus for their creative activities is derived from free interactions with others, free exchange of opinions in writing and in speech, by means of letters or publications, and by personal contact (for which free traveling is necessary), in order to stimulate a free exchange of opinions and free mutual criticism between the most diverse elements of our human society. What we call "democratic society" offers the best possibilities for this aim. I know that we have not found a definite form of democratic society, there must always be development, but the best approximation to our democratic ideals must embody the thought expressed by Wells in one of the chapters of "The Work, Wealth and Happiness of Mankind": "Our world is now launched upon a perpetual investigation and innovation, and its ideals of education is no longer the establishment of static ideology, but the creation of a receptive and co-operative alertness".

My scientific work did not permit me to go into philosophical studies as far as would have been needed for writing essays about these issues, although I have sometimes gathered material for this purpose. Some thought have been expressed in minor publications, namely, in a paper on "Entropy and Relation to Function of Life" (1943), in an essay on "Aspects of Modern Western Science" (1944), and in an invited address read before the joint meeting of the two divisions of the Royal Netherlands Academy of Sciences in April 1953 (all these papers have been published, in Dutch, in periodicals of the Academy).

There was one aspect of these problems which came more close to scientific work proper: the relations between science and society. These had begun to attract attention in wide circles of scientists since 1920, and, in particular between the years 1930 and 1940, when the leading British scientific journal "Nature" devoted much space to this subject. I found interest for these matters among several members of the Royal Netherlands Academy of Sciences. In particular, this applied to Professor H. R. Kruyt, who was vice-president of the section of sciences from 1931 to 1947. We considered whether it might be possible to start some work on an international scale, through the International Council of Scientific Unions (Professor Kruyt and I have been regular delegates to the meetings of the International Council for the Academy of Sciences since 1934). At the same time we felt the need for research to be carried out in the Netherlands. In 1938 Kruyt mentioned to me that Professor R. de Joselin de Jong, emeritus professor of medicine, then living in Driebergen, was very much interested and was prepared to undertake research on this subject. A small group of scientists joined us, and we proposed an organization to promote research into the relations between science and society. We had many meetings in Driebergen and drafted a set of statutes, on the basis of which a "Stichting" (Foundation) was created by a deed before Mr. Arie de Mos, notary public in The Hague on 7 February 1940. However, the war of 1939-1945 had already broken out. It came to the Netherlands in May 1940 before any work was undertaken. It was hopeless to continue anything of this kind under the German occupation.

During the Nazi occupation the Technical University in Delft suffered many difficulties. The professors of Jewish birth were dismissed in November 1940; the students went on strike (the same happened in Leiden) and both the universities in Delft and Leiden were closed for teaching to the students. The universities in Amsterdam, Utrecht and Groningen closed at the same time on their own account. The University in Leiden never re-opened during the Nazi occupation, but the Technical University Delft could resume its teaching in May or June 1941. Much was done by the staff to make up for the loss of time the students had suffered (during the period of suspension of teaching I had taken part, for instance, in a private seminar on aeronautics). Very serious difficulties arose in February 1943: on the 6th of February the German police suddenly came to several buildings and arrested the students because of an alleged cooperation with an attack on some pro-German Dutch official in The Hague. Teaching again had to be suspended. A number of students were transported to Germany for forced labor. After some months it was announced that teaching could continue for those students who would sign a declaration of loyalty with the prospect of having to work in Germany after having completed their courses.

The alternative was to be taken to Germany immediately (unless one could go in hiding, which was impossible for many of them). The University Senate, after long discussion, advised the students to sign (we were prepared to graduate not a single student and to keep a secret record of their progress for graduation after the occupation would have ceased). The Netherlands government in exile in London advised the students by radio to go into hiding. With a greatly reduced number of students the University continued operating until the beginning of 1944, when further teaching became completely impossible through a combination of circumstances. Moreover, in September 1944 the big railway strike came as ordered by the exiled government; all transportation stopped and soon after that gas and electricity ran out.

I have taken full part in all discussions with my colleagues, privately, in the Department of Mechanical Engineering, and in the Senate; moreover, I often contacted groups in other cities. Together with my colleagues, I have done my best to help students where I could.

During the war, thoughts about social problems kept many of us busy. When during the fall and winter of 1944-1945 the possibility for doing scientific work was practically reduced to nil, talks with some academic friends at Amsterdam, Leiden and The Hague again raised hope for creating some center of research for such problems. Since communications between the various cities were becoming difficult, it was not possible to get into close contact with Professor de Josselin de Jong, who also was not in very good health. However, I found others who were very much interested and after many discussions on what we considered as most important to be done, we drafted statutes for a new society with a larger scope than the previous foundation. Among the persons cooperating were Dr. F. Bakker Schut, director of the Government Bureau for the National Plan; Professor W. Schermerhorn, who became the first prime minister of the Netherlands after the liberation; Ir. F. Q. den Hollander, who afterwards became director of the Netherlands Railways; Professor N. Posthumus, who became director of the Government Bureau for War documentation; Mr. J. In 't Veld, who became minister for housing ("volkshuisvesting"), Ir. L. Mansholt, who became minister of agriculture, Ir. H. Vos, who became minister for commerce and industry; Dr. C. H. van der Leeuw, director of "Van Nelle", Rotterdam. On July 19, 1945, by a deed before Mr. Jacob Tiedama, notary public in The Hague, a new foundation was created, called "Research Center for Social Problems".

Before the liberation and also during the first months of freedom, we had worked hard to prepare a set of memoranda on various social problems which we expected to come to the foreground in the reconstruction of our national life (general reconstruction questions; planning for the entire country; medical care; housing; public works; protection of nature and care of the landscape; education; cultural meaning of daily work; principles of economic reconstruction; etc.). Meetings were arranged for discussing these and other subjects.

Our financial means, however, were very limited. We had hoped to obtain semi-official status for the Research Center by support from the government. I even seriously considered whether I should devote myself completely to work in this direction which would imply leaving my scientific work, but Professor Schermerhorn had so many other things to attend to, that we were not a priority. We might have obtained recognition, if we could have worked somewhat in the way of the British Society "Political and Economic Planning", which from its proper financial means could undertake social research leading to publications. Our means, however, could not be compared with those of this British organization and what proved worse: most of the people with whom I had planned the work, suddenly proved to be so heavily charged with obligations, that they no longer had time for discussions, still less for undertaking any definite research work. Hence, all responsibility fell on my own shoulders.

Then in August 1945 I was invited to travel to England with a group of assistants of our Technical University, in order to study scientific literature and scientific progress made during the war years, from which the Netherlands had been completely cut off during the occupation. It was my task to provide for the necessary introductions (I had many relations with scientists and with scientific institutions in England) and to guide the assistants in their work. I also received full freedom to study what had been the research on social programs. The trust put in me was very gratifying and I was glad to accept the offer. It took some time before all the necessary preparations were completed; I went alone during the month of November 1945, and then from January 1946 until the end of March a group of 12 assistants came over with me: all very capable young persons, who had been carefully selected.

Our mission was a great success. We were introduced to the National Physical Laboratory in Teddington and to a great number of university laboratories; we had contact with the Department of Scientific and Industrial Research, and with the Patent Office; we went to Cambridge, Manchester and other universities; everywhere colleagues and officials helped us and a large number of references, abstracts and data was brought back to Holland. The Netherlands Government provided an extra grant for the purchase of scientific periodicals, in particular back issues which were missing in Holland; and the British "Help Holland Council" gave us a grant of £b 2000 for the purchase of scientific equipment. Much goodwill was obtained.

Although Holland had been cut off from contact with other countries, it turned out that our work during the occupation had not been unfruitful. In my own area of aerodynamics I found that some of the questions with which I had occupied myself, were of interest to foreign scientists. I was asked to give some scientific lectures. Gradually this drew me back to my original domain of work, and although I gathered interesting information and research on social problems and on various questions of education, science began to regain the heavier weight.

Upon coming back to Delft, it appeared that the Netherlands Navy, engaged in dismantling some submarines and other ships, was willing to offer part of the equipment to several laboratories of our University, and my laboratory in particular could get high-pressure equipment. Moreover, I was told that I could get additional laboratory space, while at the same time the staff of the laboratory would be enlarged. This opened perspectives which required due consideration, and since the new developments of high-speed flow interested me very much and offered a promising topic for theoretical as well as for experimental work, I felt all the attractions of a scientific work returning to me. Since at that time all my collaborators in the Research Center project had departed on their various ways, I took the unavoidable decision: I returned fully to my University work.

(Although not directly connected with the history of the "Research Center", it may be of interest to mention that during the last winter of the occupation several more projects for the creation of new organizations had been made. One of these was the "Nationaal Instituut" for the purpose of making men and women more conscious of our cultural heritage. This "Nationaal Instituut" obtained large government grants and a sumptuous building in Amsterdam to organize its work. Our "Research Center" had personal ties with this institute and there was a kind of agreement concerning cooperation; however, the "Nationaal Instituut", was not directed towards research. The "Nationaal Instituut" was dissolved a few years after the liberation).

I am convinced that the only effective way to protect human society against the spread of disruptive trends of thought, as Nazism, the present form of communism, race conflicts and what further may develop, must be

(a) helping those peoples and those social groups which suffer deprivation;

(b) extensive research into man's reactions to changes of his environment, to the increase of knowledge and to the tremendous increase of technical power, including attention to influencing thought and emotional life.

If we do not embark on such research on a much wider scale than is currently pursued, with determination to give full attention to its results, there will always reappear maladjustments with the consequence of misunderstanding, fear and outbreak of destructive instincts.

I have done my best to organize and to stimulate such research, in discussions, in letters, in articles, and in the way I have described in the preceding pages. That is what I did in order to cope with the destructive trends which appeared in communism and elsewhere. Had I found active collaborators, not tied down by other work, I might have achieved something, either in my own country or in some international form. I went as far as I could with the means at my disposal and gave a great deal of my time to it. In this way I have tried to do something much more useful than would have been the case if I had initiated some action against the communist party in Holland after I had left it. I left it without scars, as I mentioned before, but not with indifference. As far as I could stretch my time, I have tried to prepare myself for a better understanding and for finding means to help others towards understanding. At last, however, I had to come to the conclusion that it was better to restrict the application of my abilities to science.

Since then I have given all my time to my task at the Technical University and to the scientific work connected with it. As mentioned before I was secretary of the International Union of Theoretical and Applied Mechanics from 1946 until 1952. I arranged various symposia and took care of many publications while publishing at the same time my own theoretical research. I was also secretary of an International Committee for Rheology (problems of viscous flow and of plasticity) and took a leading part in the organization of the first International Congress of Rheology in Scheveningen, Holland, in 1948.

I was elected vice-president of the section of sciences of the Royal Netherlands Academy of Sciences in 1947, a post from which I resigned in 1950 in connection with my upcoming stay in the United States from August 1950 to August 1951. I received honorary doctor's degrees in recognition of my work in 1948 from the "Université Libre de Bruxelles" and in 1950 from the Université de Poitiers, France.

Finally, I shall make some remarks about my connections with the United States. I have already mentioned my first visit to California in 1931 upon the invitation of Dr. W. F. Durand from Stanford University.

In 1938 I wanted to attend the Vth International Congress of Applied Mechanics in Cambridge, MA, and Professor Biezeno and I had planned to make a trip to the West Coast after the Congress. On my arrival in Baltimore, however, I was called back by telegram in connection with a serious illness of my wife, which obliged me to return home immediately. She died in August 1939.

After the war new contacts with American scientists were made at the Congresses for Applied Mechanics in Paris (1946) and London (1948).

In 1949 I was invited by the Naval Ordnance Laboratory in White Oak, Silver Spring, MD to participate in the dedication ceremonies for the new supersonic wind tunnels and to give one of the lectures which were scheduled for that occasion. I took as subject "Borderline regions between aerodynamics and physics." I also worked at the laboratory as a consultant for twelve days. During a short visit to the California Institute of Technology at Pasadena, I was invited to stay again at that institution in the academic year 1950-1951 for a period of six months to work in the Hydrodynamics Laboratories collaborating in a project concerned with turbulent fluid motion and to give a series of lectures.

I also received some other invitations in addition to the one from the California Institute of Technology opening the possibility for staying in the U.S for an entire year. I had married again in 1941 and Mrs. Burgers and I sailed for New York in August 1950. We spent a few days in New York and Brooklyn; then we went to Cornell University, Ithaca, NY, to give a lecture and to do some work in the Department of Aeronautical Engineering. From Cornell we went to Cambridge, MA, to participate in the International Congress of Mathematicians, as a delegate both from the Royal Netherlands Academy of Sciences and from the International Union of Theoretical and Applied Mechanics. This was followed by a short stay in Providence, RI, to take part in a Symposium on Plasticity at Brown University. From there we went to Washington, DC.

I then had to take part in a symposium on problems of motion of the Earth's crust, which as mentioned before, had been arranged upon my recommendation by the International Union of Geodesy and Geophysics. I further worked for some time as a consultant at the Naval Ordnance Laboratory in White Oak, MD, and gave a lecture at the Brooklyn Polytechnic Institute and one at the Department of Aeronautics of the John Hopkins University in Baltimore.

On October 15 we left Washington DC and visited Dayton, OH, where I had to discuss some arrangements at the Central Air Documents Office referring to the printing of the proceedings of the first Symposium on Cosmic Aerodynamics. I gave lectures at Indiana University in Bloomington, IN, at the State University of Iowa, Iowa City, IA, at the University of Utah in Salt Lake City, UT. After a short visit to Death Valley and to the Hoover Dam, we arrived in Pasadena on November 1, 1950.

During my stay in Pasadena I worked daily in the Hydrodynamics Laboratories of the California Institute of Technology, gave a series of lectures, and took part in many seminars. On several occasions we were taken out by colleagues on trips or on larger excursions. I also was twice invited to give lectures at the Naval Ordnance Test Station, Inyokern, CA. In addition, I gave a lecture at Stanford University and one at the University of California, Berkeley, CA.

We left Pasadena on May 27th, 1951, visited the Grand Canyon, Flagstaff, Monument Valley in Utah, Santa Fe; spent one day in Denver and then went to Chicago, where I had to take part in the first U.S. National Congress for Applied Mechanics. From Chicago we returned to Washington DC. I had to give some lectures at the University of Maryland. Thereafter, we again went to Cornell University for work as a consultant at the Aeronautics Department; to Baltimore for a lecture and to work at the Aeronautics Department of the Johns Hopkins University; and to Langley Field, VA, for a lecture. After a further stay in Washington and work as a consultant at the National Bureau of Standards, we spent the last week in Brooklyn and sailed home in the end of August 1951.

Already during the Congress in Chicago, there had been discussions about a lasting connection with the University of Maryland (I know that the California Institute of Technology was likewise interested in having me). Soon after my return in Holland, I received an offer for a full professorship, which would make it possible for me to reside permanently in the United States.

Travelling through the United States and the many contacts we had made with people in that country had made a deep impression on Mrs. Burgers and on me. We had obtained an understanding of many aspects of life in that country and of its problems. We have been struck by the openness with which problems are discussed, and by the freshness of outlook and the eagerness to do things. We have been impressed very much by the way in which the problems of education are attacked and are held in the center of attention. There is an interest for experimenting, for looking towards new ways and a readiness to do work on those, which is extremely refreshing and which gives great hope for advance. After our return home we have talked about this with many of our acquaintances; Mrs. Burgers also gave lectures to some small groups. Moreover, we have been profoundly impressed by the great friendship, hospitality and courtesy with which we have been received everywhere and we have learned to love this country very much.

Before our marriage, which as mentioned took place in 1941, Mrs. Burgers had worked for 13 years in Rotterdam as an official of the Society for Fighting Tuberculosis. After our marriage, she became interested in child care, in particular related to children who cannot be taken care of by their parents or whose parents have been deprived of the rights of parenthood by a court decision.

Until 1950 she worked in Delft with the society "Tot Steun", a Protestant society for taking children in foster care. I mention this, because during our stay in Pasadena, Mrs. Burgers succeeded in making contact with organizations of a similar nature in the United States and she assisted at a regional congress on child care in Pasadena in April 1951. She took part in the discussion and was invited to give an informal talk about child care in Holland. She was also invited to visit some children in their foster homes. Having come across a book by Mrs. Ann Perrot Rose, "Room for One More", which treats the problem of taking foster children into one's family in a very clear and attractive way, she decided to translate this book into Dutch. After a publisher had been found and the necessary copyright permit was obtained from Mrs. Rose, the book has appeared in Holland under the title: "Er kan nog meer bij" (D. van Syn en Zonen, Rotterdam, 1952); 1800 copies have been sold.

One can see that both of us have done our best to promote a mutual understanding and respect between Holland and the United States.

Both of us love our country and the surrounding countries of Europe; we have seen much of England, France, some parts of Switzerland, Italy, Germany, and Denmark; in 1952 we were in Istanbul. What Holland and Europe have given to us is firmly anchored in our minds. Both of us have given all our energies to work in the interest of our country. Our connections with Holland and Europe will never be lost.

However, if, after having been in Europe for so many years, the opportunity would be granted for us to share the life of the United States, we would consider this as a great happiness. It would widen our horizon and we would like to collaborate with the Americans towards the realization of their ideals, so that we may become good and helpful inhabitants of that country.

Epilogue

The ideal of communism as it presented itself around 1918 promised to open a road towards a better understanding of social problems and towards widely improving conditions of living and of education, in a world which was deeply wounded by the bloody struggles of World War I. It was hoped that the revolution in Russia had liberated great forces which would bring immense progress in the world. What has happened in Russia, after an initial period which had looked promising, has blurred the ideal of communism so much, that it is totally impossible to reconstruct it.

If I would be asked to state my opinion about communism, I shall therefore be unable to give an answer, unless a clear definition is provided of what is meant by the word. However, comments can be made with respect to two forms in which this word is used:

Concerning the results of the so-called "communist government" in Russia, I am fully prepared to say that it has failed in realizing any of our hopes; instead of bringing freedom to man, it has destroyed freedom of discussion, freedom of expression and freedom of thought to such a degree that it will take a long time before the damage can be repaired. I do not even see reliable signs of a proper beginning towards such a restoration.

Concerning the activities of the communist parties, in so far as I can judge from the available information, nowhere do they give any evidence of independent constructive thinking. I am speaking here about the present situation; it was different 30 years ago. I do not know anything about trends in Yugoslavia. I add that in view of what has happened in Russia, no sensible and honest man can preach that adherence to Russian and to Russian thinking can bring happiness. To destroy social relations in democratic countries with the purpose of helping the policy of the present Russian Government is an activity which I fully condemn.

Editorial notes

Supplementary information provided by J. Herman Burgers, son of Jan Burgers: The statement of 1954 does not mention the work of Jan Burgers as secretary of the "Committee on Science and Social Relations" (ICSU) established in 1937 by the International Council of Scientific Unions. His service as a secretary led to interactions with the Chair of the Council, J.D. Bernal in the U.K., who was an outstanding scientist, but also an advocate of communism [6, 7].

Supplementary information provided by J. Robert Dorfman, colleague of Jan Burgers at the University of Maryland: The statement of 1954 does not mention the contacts of Jan Burgers with his fellow student Dirk J. Struiken, who had become a professor of mathematics at MIT, but had been suspended by MIT in 1951 after having been accused of "un-American activities" [8].

Happy ending

In February 1955 Jan Burgers submitted some additional reflections to the American Consulate supplementing the thoughts he had expressed in his earlier statement of March 1954 described above. After some further interactions with the American Consulate, Burgers was informed in June 1955 that an immigration visa would be issued and Burgers was formally appointed as a Research Professor at the University of Maryland starting September 1, 1955 in what was then called the Institute for Fluid Dynamics and Applied Mathematics.

References

1. F.T.M. Nieuwstadt and J.A. Steketee, eds., *Selected Papers of J.M. Burgers* (Kluwer, Dordrecht, 1995).
2. J.V. Sengers and G. Ooms, eds., *Autobiographical Notes of Burgers*, in: “JMBC 15 years” (JM Burgers Centre, The Netherlands, 2007), pp. 20-59 (Available at http://ipst.umd.edu/aboutus/files/burgers_autobiography.pdf; also at American Institute of Physics, Niels Bohr Library & Archives, College Park, MD 20740, USA).
3. M.J. Klein, *Paul Ehrenfest, Vol. 1: The Making of a Theoretical Physicist* (North Holland, Amsterdam, 1970).
4. D. van Delft, *Paul Ehrenfest’s final years*, *Physics Today* 67(1), 41-47 (2014).
5. G. Alberts, *On Connecting Socialism and Mathematics: Dirk Struik, Jan Burgers, and Jan Tinbergen*, *Historia Mathematica* 21, 280-305 (1994).
6. J.D. Bernal, *The Social Function of Science* (Routledge & Kegan Paul, London, 1939).
7. A. Brown, J.D. Bernal: *The Sage of Science* (Oxford University Press, 2005).
8. G. Alberts and W.T. van Est, *Dirk Jan Struik, in Levensberichten en herdenkingen 2002* (Koninklijke Akademie van Wetenschappen, Amsterdam, 2002), pp. 107-114.

Acknowledgment

The editors (J.V.S. & G.O.) are indebted to J. Herman Burgers for valuable information and documentation concerning his father.

Appendix

Translation of my letter of resignation from membership of the communist party:
Delft, 22 September 1933.

To the Bureau of the division Delft of the CPH.

Dear comrades,

Here I inform you that I wish to end my membership of the CPH. Actually I have not taken part in the work of the party already during a very long time and neither is it possible for me to do this in the future. It seems better to prevent that a false situation will result.

J.M.B.

HIGHLIGHTS

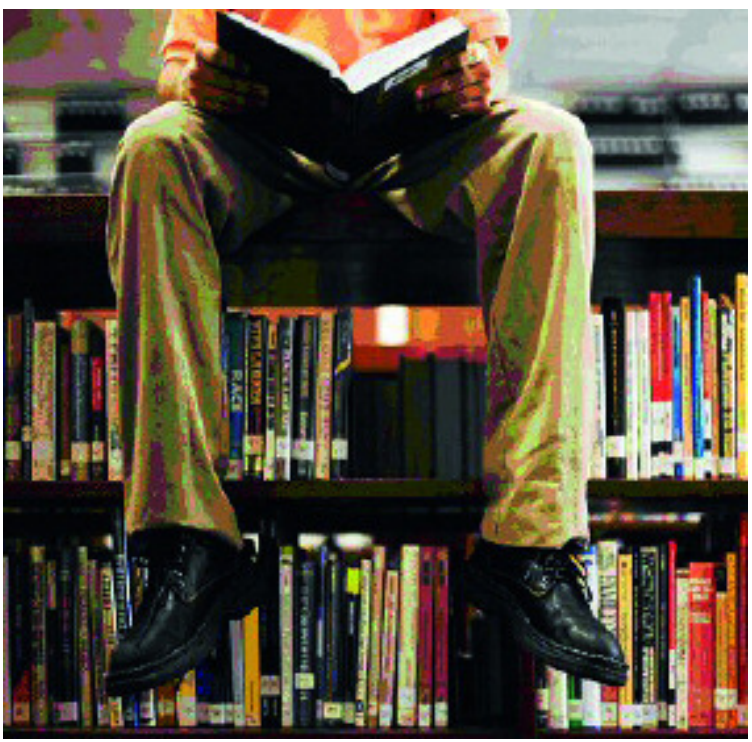

SIMULATIONS OF TURBULENT COMPRESSIBLE FLOW WITH LITTLE ARTIFICIAL DISSIPATION

W Rozema (RUG/NLR), JC Kok (NLR), RWCP Verstappen (RUG), AEP Veldman (RUG)

In simulations of compressible flow with a standard finite-volume method, small turbulent flow structures can transfer internal energy to kinetic energy through convective transport. This energy transfer violates a conservation property of convective transport, and may eventually cause hopeless numerical instability of a simulation. Therefore, finite-volume methods often need to eliminate small flow structures through artificial dissipation to attain numerical stability. However, although artificial dissipation can successfully stabilize a finite-volume method, it can also have undesirable side-effects such as numerical delay of the transition to turbulence or attenuation of acoustic waves.

The needed level of artificial dissipation can be reduced by enforcing conservation of kinetic and internal energy by convective transport at the discrete level. We found that this can be done straightforwardly if the state of a compressible fluid is expressed in the square root variables $\sqrt{\rho}$, $\sqrt{\rho} u/\sqrt{2}$, and $\sqrt{\rho e}$. In these variables the conservation of mass, momentum, kinetic energy, internal energy and total energy by convective transport can all be explained from a mathematical skew-symmetry. If this skew-symmetry is preserved by a simulation method, then discrete convective transport does not only conserve mass, momentum, and total energy as in a standard finite-volume method, but also kinetic and internal energy separately.

This contour plot of the axial vorticity above the delta wing shows the primary vortex and the upper surface boundary layer (blue) which is sucked into the primary vortex. Although some light spurious wiggles can be observed, these do not cause numerical instability because the simulation method preserves symmetries.

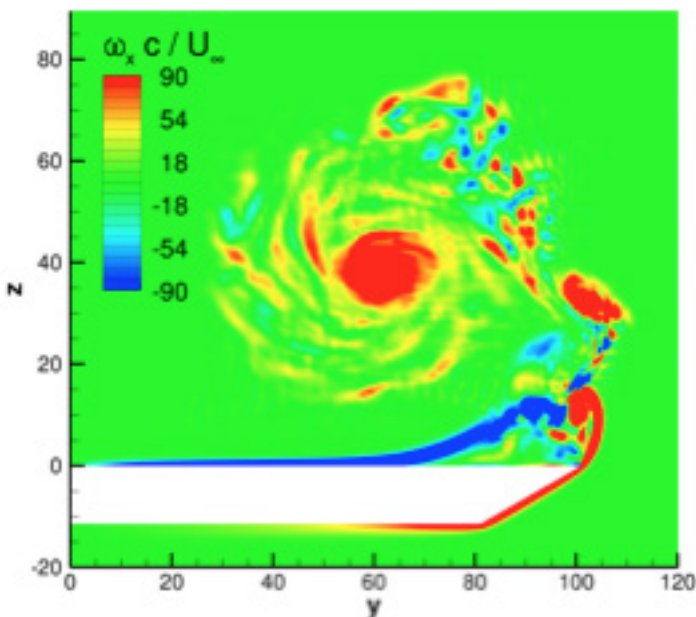

A skew-symmetry-preserving simulation method needs little artificial dissipation for stability. This is demonstrated in simulations of the transitional compressible flow over a delta wing. The flow over a delta wing is dominated by two primary vortices, which are formed by roll-up of the shear layer that emanates at the leading edge of the wing. The simulation method is fourth-order accurate, the computational grid stretches and bends considerably, and the primary vortices feature many small flow structures. However, because the skew-symmetry of convective transport is preserved at the discrete level, the simulation is stable without artificial dissipation close to the delta wing. Because the simulation method understands that convective transport conserves kinetic energy, artificial dissipation is an option and not a necessary condition for numerical stability.

REFERENCES

1. W. Rozema, J. C. Kok, R. W. C. P. Verstappen, A. E. P. Veldman, A symmetry-preserving discretization and regularization model for compressible flow with application to turbulent channel flow, *J. Turb.*, submitted.
2. J. C. Kok, A high-order low-dispersion symmetry-preserving finite-volume method for compressible flow on curvilinear grids, *J. Comput. Phys.* 228, 2009, p. 6811–6832.

The transitional flow over a delta wing at $Re = 50,000$ visualized as an iso-surface of the q -criterion colored by the axial vorticity.

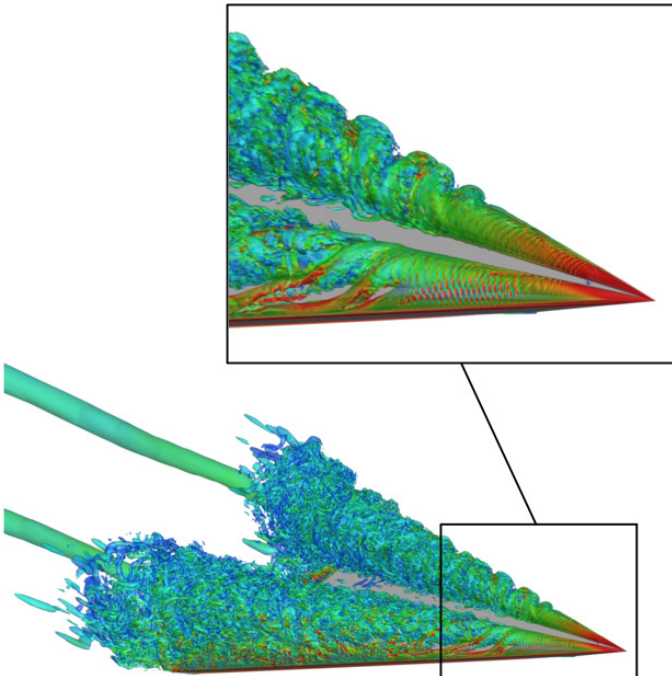

ACOUSTIC DROPLET VAPORIZATION

O Shpak, D Lohse, M Versluis (UT)

Current tumor chemotherapy is associated with severe side effects caused by adverse effects of the drugs on healthy tissue. A local delivery of the drug has the advantage of a more controlled biodistribution of the therapeutic agent, which will reduce the side-effects, and offers the potential to use a higher concentration which will improve therapeutic efficiency. Recent studies have shown that liquid emulsion microdroplets of a size of 10 μm composed of a low-boiling point perfluorocarbon (PFC) have the potential to be a highly efficient system for local drug delivery. Moreover, nanodroplets of a size of 100 nm can extravasate through the leaky vessels of a tumor and the drug can be released upon triggering with diagnostic ultrasound while an explosive evaporation of the droplet takes place.

From the experiments it appears that the vapor bubble formation is governed by a complex interaction between droplet and ultrasound, and that the combined effect of pressure, dissolved gas concentration and local temperature contributes to the cavitation process. The details of how and why this works, the physical understanding of the vapor bubble dynamics, remains unexplored owing partly to the extremely fast timescales of the phase conversion process.

We use ultra-high speed optical imaging to study, for the first time, acoustic droplet vaporization dynamics at nanoseconds timescales. We develop a simple theoretical model to capture all of the growth dynamics prior to and following the nucleation event at the time scales under study here. We show that on these time scales the evaporation process is limited, not by the kinetic theory of the mass flux, but by the heat transfer from the containing liquid into the vapor bubble required to supply the latent heat for a phase conversion. We also take into account the interaction of the vapor bubble with the applied ultrasound and explain that the phase conversion rate is much more rapid due to rectified heat transfer. And, we recover the driving pressure information from the optical recordings and determine the exact phase of ultrasound when nucleation is initiated.

Nonlinear propagation of the acoustic wave leads to the formation of a shockwave composed of higher-order superharmonics that focus efficiently into the droplet, triggering the nucleation event. Snapshots from the ultra high-speed recordings taken at a frame rate of 20 million frames per second display the focusing effect with excellent spatial and temporal agreement with the numerical predictions.

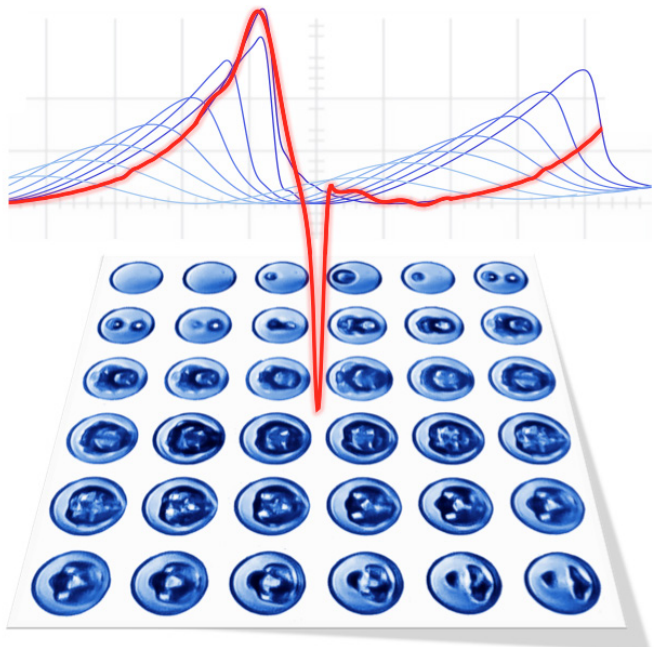

We also explain the long-standing puzzle how ultrasound can physically trigger the vaporization given the large mismatch between the ultrasound wavelength and the microdroplet size. We show that vaporization is preceded by nonlinear propagation of the ultrasound wave generating superharmonics. These high-frequency waves focus efficiently within the droplet, triggering vaporization. ADV shows great potential for advanced medical diagnosis and therapy. Our new understanding allows for further reduction of the required pressure amplitudes, thereby minimizing the adverse effects on healthy tissue. As a result of the therapeutic effect of these droplets can be controlled and monitored with ultrasound and following these new imaging and activation protocols a next step in tumor treatment efficiency can be made.

REFERENCES

1. Oleksandr Shpak, Tom Kokhuis, Ying Luan, Detlef Lohse, Nico de Jong, Brian Fowlkes, Mario Fabiilli, and Michel Versluis, Ultrafast dynamics of the acoustic vaporization of phase-change microdroplets, *J. Acoust. Soc. Am.* 134, 1610–1621 (2013).
2. Nikita Reznik, Oleksandr Shpak, Erik Gelderblom, Ross Williams, Nico de Jong, Michel Versluis, and Peter N. Burns, The efficiency and stability of bubble formation by acoustic vaporization of submicron perfluorocarbon droplets, *Ultrasonics* 53, 1368–1376 (2013).
3. Oleksandr Shpak, Laura Stricker, Michel Versluis, and Detlef Lohse, The role of gas in ultrasonically driven vapor bubble growth, *Phys. Med. Biol.* 58, 2523–2535 (2013).
4. Oleksandr Shpak, Martin Verweij, Rik Vos, Nico de Jong, Detlef Lohse, and Michel Versluis, Acoustic droplet vaporization is initiated by superharmonic focusing, *Proc. Natl. Acad. Sci. USA* 111, 1697–1702 (2014).

M van Sint Annaland, F Gallucci, I Roghair (TU/e)

A large increase in process efficiency can be accomplished with novel intensified reactors based on integration of reaction and separation. An important example is the fluidized bed membrane reactor for ultra-pure hydrogen production by autothermal or steam reforming of hydrocarbons. In this type of reactors hydrogen perm-selective membranes are immersed in the catalytic fluidized bed to selectively extract the ultra-pure hydrogen product from the reaction mixture, thereby also shifting the equilibrium reactions towards completion at much lower temperatures than conventional reactors. Thanks to the enormous improvement in membrane preparation, membranes with very high permeation fluxes combined with extremely high perm-selectivities have become available. How and to what extent the extraction of large amounts of gas affects the fluidization behavior in terms of fluid dynamics (viz. solids circulation patterns and bubble size distributions) and mass transfer rates (concentration polarization) remain the most important unanswered questions hampering full exploitation of membrane fluidized bed reactors.

Another interesting example of process intensification is chemical looping combustion and reforming processes, where air separation is achieved via a solid oxygen carrier (supported metal particles), accomplishing fuel conversion with integrated CO₂ capture. The effects of high temperature gas-solid reactions, particle residence time distributions and solids addition/extraction on the hydrodynamics in these reactors are not yet fully understood.

For better understanding and further development of novel integrated multi-phase reactors, there is a grave need for reliable, non-invasive experimental techniques to measure hydrodynamics and gas and solids concentration profiles under actual reactive conditions, which often imply very high temperatures.

Schematic representation of the IR-PIV/DIA technique

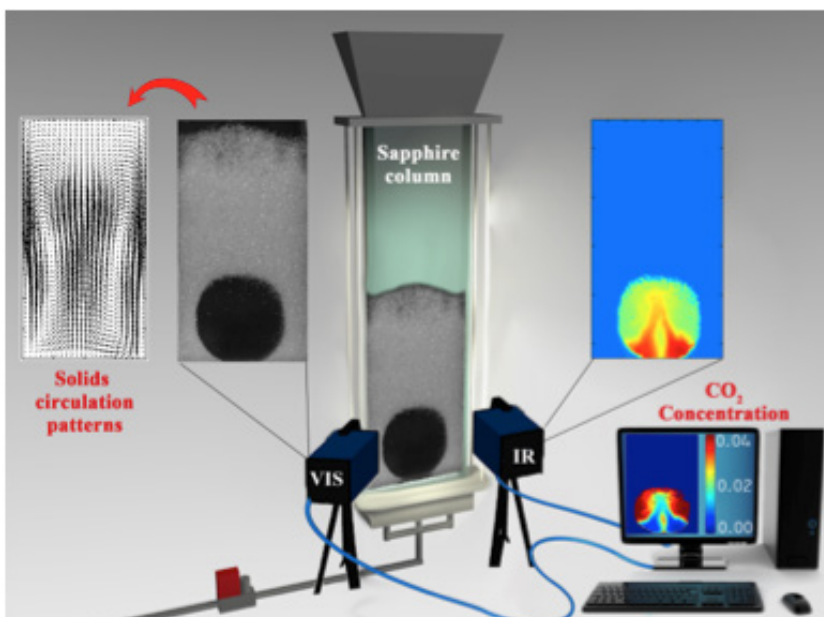

In the Chemical Process Intensification group at TU/e two new experimental techniques are being developed for detailed monitoring of fluidized bed (membrane) reactors under reactive conditions.

The first technique allows non-invasive, whole-field gas concentration measurements in a pseudo-2D, gas-solid fluidized bed with high temporal and spatial resolution. The technique is based on digital image analysis (DIA) of images acquired with an infrared (IR) and a visual (VIS) high-speed camera (see Fig. 1) to obtain the local gas-phase concentration field of a tracer gas [1], which is combined with particle image velocimetry (PIV) to also obtain the solids flux and porosity profiles simultaneously. This technique has been applied to investigate bubble-to-emulsion phase mass transfer and gas mixing characteristics in bubbling and turbulent fluidized beds.

Secondly, the application of particle image velocimetry and digital image analysis techniques is further extended to (very) high temperatures applications (up to 1000 °C). This is made possible with the aid of two high temperature endoscopes (see Fig. 2), one to acquire the images and one for illumination via a laser [2]. The experimental results will be also used to validate CFD-based reactor models (TFM/DPM) and improve phenomenological models for integrated fluidized bed (membrane) reactors.

REFERENCES

1. T.Y.N. Dang, T. Kolkman, F. Gallucci, M. van Sint Annaland, Development of a novel infrared technique for instantaneous, whole-field, non-invasive gas concentration measurements in gas-solid fluidized beds, *Chem. Eng. J.* 219 (2013) 545–557.
2. I. Campos Velarde, L.J. van Heck, F. Gallucci, M. van Sint Annaland, Development of a high temperature endoscopic PIV/DIA technique for the study of hydrodynamics of gas-solid fluidized beds, *Fluidization XIV*, Eds. Kuipers et al., May 26-31 (2013) 739-746.

Schematic representation of the high-temperature endoscopic PIV/DIA technique

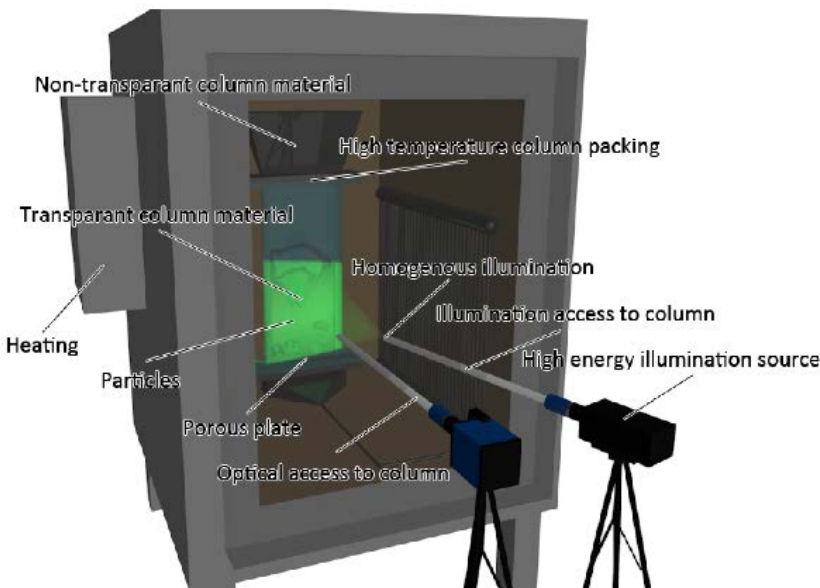

EH van Brummelen (TU/e)

The added-mass effect that an encompassing fluid exerts on a moving solid body was intensively investigated in the 19-th century in the context of the motion of pendulums. The first written account of this effect appears to be the paper by Stokes, read before the Cambridge Philosophical Society in 1850 [6], although this paper mentions earlier work by Bessel from 1828. A side note of historical interest is that Stokes' analysis in [6] is based on equations that he had derived five years earlier and that have come to bear his name together with that of Navier.

Evidently, pendulums have dwindled as an object of active scientific investigation. The addedmass effect has however recently regained interest on account of its influence on the convergence behavior of iterative solution methods for fluid-structure-interaction (FSI) problems. The ratio of the added mass to the structural mass is critical to the convergence-and-stability properties of partitioned iterative solution methods for FSI. In the basic iterative method for FSI problems, the fluid and solid subproblems are solved alternatingly subject to complementary partitions of the interface conditions. The convergence rate of this so-called subiteration process coincides with the fluid-structure mass ratio. Therefore, subiteration is unstable if the fluid-structure mass ratio exceeds one while, conversely, it provides very effective convergence for FSI problems in which the added mass of the fluid is much smaller than the structural mass.

The added mass of incompressible flows and its effect on the convergence behavior of partitioned solution methods has been investigated in [1, 3, 5]. In [1], we have in addition established the added-mass effect of compressible flows.

$10 \log$ of the error ϵ_n in the subiteration process versus the iteration counter n for fluid-structure mass ratios (from bottom to top) $\sigma = 2^{-2}, 2^{-1}, \dots, 2^4$ (see [2]).

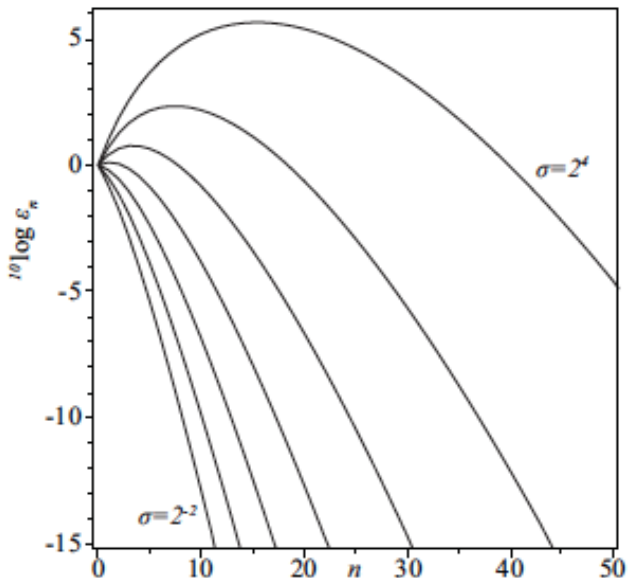

Our analysis conveys that, essentially, the added mass of a compressible flow is proportional to the duration of the time interval under consideration (i.e., the time step in the numerical time-integration procedure), whereas the added mass of an incompressible flow approaches a constant as the time interval vanishes. Consequently, regardless of the density of the fluid and the mass of the structure, for compressible flows the subiteration process is stable and convergent for sufficiently small time steps. For incompressible flows, this is not the case, and the subiteration method can remain unstable in the limit of vanishing time-step size. This implies, in particular, that loosely-coupled (or staggered) time-integration schemes, in which only a single iteration per time step is performed [4], are in general suitable for compressible-fluid-structure-interaction problems, but not for incompressible-fluid-structure-interaction problems. In [2] we have conducted a refined analysis of the subiteration operator for compressible- and incompressible-flow models, to serve as a basis for the analyses of several partitioned solution methods which use subiteration as a component. We established that for compressible flows, subiteration corresponds to a Volterra operator, which is quasi-nilpotent and nonnormal. This implies that for compressible flows and large time steps, the subiteration method can yield non-monotonous convergence.

To illustrate the convergence behavior of subiteration for compressible flows, Figure 1 plots the error ϵ_n versus the iteration counter n for mass ratios $\rho CT/\mu =: \sigma = 2^{-2}, 2^{-1}, \dots, 2^4$ with ρ as fluid density, C as speed of sound, T as time step and μ as structure density. At large time steps, transient divergence occurs before asymptotic convergence sets in, as a result of non-normality. The convergence behavior improves as the time step and, accordingly, the added-mass decreases.

REFERENCES

1. E.H. van Brummelen. Added mass effects of compressible and incompressible flows in fluidstructure interaction. *J. Appl. Mech.*, 76:021206–7, 03 2009.
2. E.H. van Brummelen. Partitioned iterative solution methods for fluid structure interaction. *Int. J. Numer. Meth. Fluids*, 65:3–27, 2011.
3. P. Causin, J.F. Gerbeau, and F. Nobile. Added-mass effect in the design of partitioned algorithms for fluid-structure problems. *Comput. Methods Appl. Mech. Engrg.*, 194:4506–4527, 2005.
4. C. Farhat. CFD-based nonlinear computational aeroelasticity. In E. Stein, R. de Borst, and T.J.R. Hughes, editors, *Encyclopedia of Computational Mechanics*, volume 3: Fluids, chapter 13, pages 459–480. John Wiley & Sons, Ltd., 2004.
5. C. Förster, W.A. Wall, and E. Ramm. Artificial added mass instabilities in sequential staggered coupling of nonlinear structures and incompressible viscous flows. *Comput. Methods Appl. Mech. Engrg.*, 196:1278–1293, 2007.
6. G.G. Stokes. On the effect of the internal friction of fluids on the motion of pendulums. *Transactions of the Cambridge Philosophical Society*, 10:8–106, 1851.

RESEARCH



RESEARCH

INTRODUCTION

The research programme of the JMBC has been ordered in research themes and focal points. The reason for this ordering is to present a combination of projects which have coherence, either in terms of physical models or in terms of mathematical methods.

The main themes are:

1. Complex dynamics of fluids
2. Complex structures of fluids
3. Mathematical and computational methods for fluid flow analysis

DESCRIPTION OF THE RESEARCH THEMES

1. COMPLEX DYNAMICS OF FLUIDS

Fluid flows in the environment or in industrial applications are almost always characterised by some form of complexity. Frequently it is this complexity that makes the flow an interesting topic of research. Below we will sketch several examples of such flows and flow phenomena which form research topics carried out in the various groups of the J.M. Burgerscentrum.

The first form of complex dynamics which comes to mind is turbulence in contrast to a laminar flow. Here complexity appears in the form of strong non-linearity. Due to its chaotic behaviour turbulence can be considered as the archetype of a complex flow, and - being far from solved - turbulence will remain a strong focal point of research in the coming period. Turbulence research traditionally addresses the following questions:

- ♦ what are the physical processes and interactions governing turbulence,
- ♦ how can they be quantified and described mathematically,
- ♦ how to predict turbulence and turbulent flow for particular configurations, and
- ♦ how to control and manipulate turbulence?

Future research in this field in particular will focus on laminar-to-turbulent and reverse transition, effects of thermal buoyancy, unsteadiness, compressibility and rotation, and on the interaction with chemical reactions. The role of turbulence in energy conversion processes and equipment are regarded as an intriguing field of applications.

Complexity may also appear in the form of a combined flow of various phases. When these phases are immiscible, phenomena such as free surface flows occur. These may appear in the form of various wave phenomena, for instance on an unobstructed water surface, but also in a confined geometry of a pipe.

Another type of such flow of immiscible phases is when one of the phases is distributed in the form of small particles, bubbles or droplets in the other continuous phase. Various combinations of phases may be selected and each has its own particular problems. This class of flows, generally denoted as dispersed multi-phase flow, at the moment forms a strong focal point of research within the JMBC. The combination of phases that are miscible leads to other interesting problems such as mixing, and - depending on the fluids that take part in the mixing - chemical reactions or combustion.

Finally, complexity of the flow can also appear through its boundary conditions. For instance the flow geometry can strongly influence the flow characteristics by means of straining, shearing and distortion. An example is the wake behind a body in a shearing or straining flow.

Furthermore, the exact formulation of boundary conditions can have a consequence for the type of flow characteristics that appear.

An example is the free convection above a flat surface with a variable the conductivity. Geometry constraints on the flow are also dominant also when one considers a flow in 2D versus 3D. Here one should take as an example the quite different characteristics of 2D turbulence versus 3D-turbulence.

An increasingly important JMBC research activity within Theme 1 is aero-acoustics, aimed at the identification and quantification of acoustic sound sources in internal and external flows. Such sources can be related to unsteady vortex shedding, turbulence, combustion and flow-structure interaction. In general there is a strongly non-linear mutual interaction between sound source and acoustic field. The applications and technical implications show a great diversity. The JMBC is actively involved in vortex sounds in ducts, musical instruments (like the flute and the organ pipe), human speech, acoustics in burner stabilized flames, sound generation by turbulent flames, with much attention to analytical and numerical modelling of these flows.

The flow cases mentioned above, which are by no means an exhaustive list of complex fluid flow phenomena, form research topics in the various groups in the J.M. Burgers Centre.

The tools to carry out this research are primarily numerical and experimental. The numerical techniques used to compute flow phenomena are direct and large eddy numerical simulation, turbulence modelling and computational fluid dynamics. The experimental techniques used nowadays are mostly based on various forms of laser diagnostics (e.g. like PIV and PTV for flow measurements and CARS, LIF and Cavity Ring-Down Spectroscopy for temperatures and concentrations). Experiments, simulations and analytical theories in the field of fluid flow analysis complement each other - perhaps more than in other branches of physics. Future research will inevitably make use and take advantage of combined techniques and their complementing roles. Both the research topics themselves and the research techniques to carry out these investigations, form the basis of a strong collaboration within the J.M. Burgerscentrum.

2. COMPLEX STRUCTURES OF FLUIDS

Research in this Theme deals with complex structures of flow, formed in the presence of particles, drops, or bubbles, i.e., two- or even multi-phase flow. Two-phase flow is of paramount importance in contemporary science and technology.

One can readily cite a multitude of examples: the production and transport of oil (where bubbles are purposely injected to help lift thick heavy oil to the surface, or arise due to the release of dissolved gases), energy generation (where boiling is the key process in producing the steam to drive turbines), the chemical industry (where gas-liquid reactors rely on bubbles to increase the contact area between the phases), the oceans (where breaking-wave generated bubbles are important sinks for atmospheric CO₂), sedimentation (where sinking sand particles determine the structure of our coasts), food-industry, and many others.

The challenge in single-phase flow is to understand the complicated dynamics which is generated by the Navier-Stokes equation. In two-phase flow, even the underlying dynamical equations are often not known. E.g., it is not understood why bubbles repel each other when they are close to each other.

But even when the microscopic interactions are known, it is often not clear how the macroscopic structure evolves from this microscopic interaction and the response to external forces.

In many cases instabilities are involved in the macroscopic structure formation process. Very complex self-organising patterns can evolve out of these instabilities. An important example is cluster formation in sedimentating particles and coherent structures in bubble columns and fluidised beds.

Related topics are flow-controlled nucleation and droplet growth processes in high-pressure natural gas, which have important technical applications in the natural gas industry. Different JMBC groups are involved in the design of new types of condensate separators and in the numerical description of swirling supersonic two-phase flows, while a dedicated facility has been developed in order to investigate these condensation processes in a well-defined way experimentally.

How to theoretically describe such a complex system? Two types of approaches have been described in literature: In the first type of approach, the particles/bubbles/drops are treated essentially as points, while no attempt is made to simulate their detailed response to the liquid dynamics.

The advantage of this approach is that many particles/bubbles/drops can be treated, but the price to be paid is a lot of ad-hoc modelling. Fluid dynamical simulations in which the particles/bubbles/drops are modelled through averaged equations also belong to this first type of approach. In the second type of approach the detailed interactions of the particles/bubbles/drops with the flow is simulated, paying the price that - at present - the surrounding flow can not really be turbulent

and that only “a few” objects can be treated, in particular, when the interfaces are allowed to deform, i.e., for free boundary problems (drops and bubbles).

One of the main objectives for the research in two-phase flow must be to bridge the gap between these two types of approaches and to carry out a detailed investigation of the interaction between one or a few particles/bubbles/ drops and a nontrivial flow field. Another objective must be to better understand the macroscopic structure formation process out of the microscopic interactions, and thus the instabilities in two-phase flow. It is evident that these objectives can only be achieved through a joint experimental, theoretical, and numerical approach.

On the experimental side, the challenge has always been to monitor and document as much information on the dynamics of the flow field as possible. Through the huge advances in both digital imaging techniques and information technology (see Research Theme 3), the field is now flourishing, and the research on two-phase flow will strongly benefit from this. The same is to be expected from the advances with numerical techniques (see Research Theme 4), as brute force numerics will not be sufficient to address the problem of structure formation in two-phase flow. New algorithms and techniques are required and moving toward parallel computing will be essential.

3. MATHEMATICAL AND COMPUTATIONAL METHODS FOR FLUID FLOW ANALYSIS

Advanced mathematical and computational techniques have become indispensable instruments for the description and understanding of complicated flow phenomena. This approach to fluid mechanics has evolved into a full-fledged counterpart to the experimental approach and provides new insight in complex flow physics, in for instance turbulence, combustion, multi-phase and rheological flows.

The use of computational flow models is supported with analytical techniques, which provide deeper insight in canonical flow problems, and strongly interacts with advanced experimental techniques, which are capable of measuring and visualizing complex three-dimensional unsteady flow fields. These techniques require advanced post-processing of the flow field data to understand the flow dynamics and have developed into a research subject in itself. Here tools from non-linear dynamical systems theory can be useful, as well as the decomposition of flow data through POD and wavelet analysis.

The rapid increase in computational power has significantly stimulated the use of computational techniques in flow analysis, but the development of better algorithms has been the most important source for improved numerical techniques for flow analysis.

Many flows are, however, simply too complex for computational techniques and flow modelling remains an essential issue. Compromises have to be found between the inaccuracies in flow modelling and computational constraints. In areas such as turbulent flow simulation much progress has been made through refined modelling via Large-Eddy Simulation (LES) and Direct Numerical Simulation (DNS). There is also an interest for stochastic methods, such as the use of the Langevin equation for the velocity. In the other areas the same trends have become feasible, e.g. PDF modelling in combustion and Brownian Dynamics in rheology.

It can be foreseen that the improvements in numerical algorithms and the growing computational power will open up new applications of flow analysis in other disciplines, such as chemistry, biomedicine and structural mechanics, and will continue to grow in importance. This will be stimulated by the development of new numerical techniques which can efficiently capture flow structures with large differences in length and time scales, the continuous increase in computing power, and by exploiting computational fluid dynamics in multi-physics applications.

REVIEW OF PROGRESS IN RESEARCH PROJECTS

As agreed by the project leaders of the JMBC only doctoral thesis, (contributions to) books, and publications in scientific journals and in proceedings of conferences with a referee system, are given in the output for each project. Only 2013 publications are taken up in the project descriptions.

An important output for various JMBC-groups is in the form of special reports for industries, technological institutes, etc. Those reports are not mentioned in the output of the projects. For more information, please contact the relevant project leaders.

FLUID MECHANICS



Prof.dr.ir. J Westerweel



Prof.dr.ir. BJ Boersma



Prof.dr.DJEM Roekaerts



Prof.dr.ir. RAWM Henkes



Prof.dr. JCR Hunt



Prof.dr.ir. G Ooms

Within the Department Process & Energy the chair of energy technology of prof. BJ Boersma, the chair of fluid mechanics of prof. J. Westerweel, and the chair of turbulent reacting flows of prof.dr. DJEM Roekaerts, are complemented by: dr.ir. WP Breugem, dr. P Colonna, dr. R Delfos, dr.ir. GE Elsinga, dr.ir. W de Jong, dr. R Pecnic, dr.ir. C Poelma, dr.ir. MJB Pourquie, dr. D Tam, dr.ir. M Tummers, and part-time chairs: prof.dr. B Eckhardt, prof.dr.ir. RAWM Henkes, prof.dr. JCR Hunt FRS, and prof.dr.ir. G Ooms.

The common themes of the research in the department group are: (i) turbulence and complex flows, such as multiphase flows, microfluidics, biological flows, and fluid mechanics of sports, (ii) turbulence in supercritical fluids, rotating machinery and gas turbines, energy conversion processes, and aeroacoustics, and (iii) turbulent mixing in non-reacting and reacting flows, turbulence-chemistry-radiation interaction in flames, and turbulent heat transfer.

The research is aimed at fundamental aspects of flows, but always with a clear connection to a practical application or process in industry. Experimental and computational studies are made of systems at different scales, from lab-scale to industrial scale. Detailed investigations are made using laser diagnostic techniques (such as particle image velocimetry, laser-induced fluorescence, and other spectroscopic methods) and using advanced computational models, such as large-eddy simulation and direct numerical simulation. The program responds to a substantial drive from society and industry, for example for more environmentally friendly combustion processes avoiding the formation of NO_x and particulates (soot) in industrial combustion systems (furnaces, gas turbines, engines), and for the development of energy efficient processes (e.g., through drag reduction). The activities in microfluidic flows aim at the investigation of small-scale cardiovascular flows, flow geometries with complex boundary conditions (such as microflagella), and micro-scale multiphase flows.



Prof.dr.ir. B Eckhardt

DISPERSION BY TURBULENCE IN THE URBAN ENVIRONMENT (DISTURBE)

PROJECT LEADERS

J Westerweel, GE Elsinga,
M Pourquie, HJJ Jonker, JCR Hunt

RESEARCH THEME

Complex dynamics of fluids

PARTICIPANTS

J Eisma, J Tomas, M Goudar
Vishwanathappa

COOPERATIONS

-

FUNDED

KEMA, TNO, FlowMotion, RWS

| | |
|--------------|------|
| University | - |
| FOM | - |
| STW | 85 % |
| NWO Other | - |
| Industry | 10 % |
| TNO | 5 % |
| GTI | - |
| EU | - |
| Scholarships | - |

START OF THE PROJECT

2012

INFORMATION

GE Elsinga
015 278 8179
G.E.Elsinga@tudelft.nl
<http://delftpe.nl/Chairs/FM>

PROJECT AIM

The current research proposal aims at finding the mechanisms that are responsible for the turbulent dispersion of air pollution near major urban roadways. The project focusses on complex geometries at the scale of several buildings and roadways (10-1000m), which are typical of cities. Finally, attention is given to the prediction of peak pollution concentrations.

PROGRESS

Boundary layer experiments performed at $Re\theta = 6300$ show the presence of strong shear layers throughout the complete boundary layer. These layered structures that are also present in complex urban flows are believed to have important effects on the dispersion of pollutants. A method to generate velocity and temperature inflow data for a flat-plate turbulent boundary layer is implemented in the large-eddy simulation code DALES. It has been applied to simulate the flow over a surface-mounted fence at $Re_h=5000$. In addition, the dispersion from several pollutant emissions near the fence has been investigated. Numerical simulations of turbulent channel flow at $Re\tau=360$ was performed. This data was used to extract small scale structures as mentioned in Elsinga et al. (2010). Dispersion of particles around these structures is being studied.

DISSERTATIONS

-

SCIENTIFIC PUBLICATIONS

1. Jerke Eisma, Gerrit E. Elsinga, Jerry Westerweel, Characteristics of Interfaces in a Turbulent Boundary Layer, 14th European Turbulence Conference, 1-4 September 2013 Lyon.
2. J.M. Tomas, M.J.B.M. Pourquie, H.E. Eisma, G.E. Elsinga, H.J.J. Jonker and J. Westerweel, Pollutant dispersion in the urban boundary layer, Direct and Large-Eddy Simulation 9 ERCOFTAC Workshop, 3-5 April 2013 Dresden.
3. M V Goudar, W P Breugem, G E Elsinga, Merging and Autogeneration of vortices in wall bounded flows, TSFP-8, 27-30 August 2013 Poitiers, France.

LIQUID ACCUMULATION IN NEARLY HORIZONTAL PIPELINES WITH MULTIPHASE FLOW AT LOW GAS PRODUCTION RATES

PROJECT AIM

The project aims at improving the basic understanding of a key aspect of multiphase flow in pipelines as used in the gas and oil industry, which is the liquid accumulation in systems under turndown operational conditions. The liquid accumulation in systems under turndown operational conditions. The experimental lab configuration will consist of a V-shaped piece of pipeline, representing the low spot. The turbulence levels will be measured using Particle-image Velocimetry. The experimental data will be used to improve the one-dimensional models used in the gas and oil industry, as well as in the next generation type of models, based on three-dimensional Reynolds Averaged Navier Stokes (RANS) equations.

PROGRESS

PIV experiments were carried out in a 10.3 m long horizontal transparent pipe with an inner diameter of 50 mm. Air and water are circulated in a closed loop, and the flow conditions covered are 0 to 7.5 m/s for air and 0.004 to 0.04 m/s for water. A combined 2D PIV and profile capturing technique was used. A second double frame camera was employed to capture images of the interface. The set-up was also extended with an extra laser and camera, to enable simultaneous measurement of the liquid and gas flow (to be carried out in 2014), and of the liquid/gas interface. Detailed interface statistics and phase-averaged velocity fields were obtained for laminar and turbulent wavy cases. The waves are shown to be irregular, with gravitational and capillary forces of similar magnitude. The linear wave theory provides a good approximation of the wave-induced velocity profile. The separation of wavy and turbulent motion was only partially possible due to the wide range of wavelengths and heights occurring in all the wavy cases.

DISSERTATIONS

-

SCIENTIFIC PUBLICATIONS

1. Birvalski, M., Tummers, M.J., Delfos, R., Henkes, R.A.W.M., Particle Image Velocimetry measurements in stratified air/water flow in a horizontal pipe, Proc. 16th Int. Conf. on Multiphase Production Technology, BHR Group, pp. 337-351, 2013.
2. Birvalski, M., Tummers, M.J., Delfos, R., Henkes, R.A.W.M., PIV measurements of waves and turbulence in stratified horizontal two-phase pipe flow. 10th Int. Symp. on Particle Image Velocimetry - PIV2013, Delft, The Netherlands, Paper A099, 2013.
3. Kjeldby, T., Henkes, R.A.W.M., Nydal, O.J., Lagrangian slug flow modeling and sensitivity on hydrodynamic slug initiation methods in a severe slugging case, Int. J. Multiphase Flow 53, pp. 29-39, 2013.

PROJECT LEADERS

RAWM Henkes, MT Tummers,
R Delfos

RESEARCH THEME

Complex dynamics of fluids

PARTICIPANTS

M Birvalski

COOPERATIONS

Shell

FUNDED

| | |
|--------------|------|
| Shell | |
| University | 25 % |
| FOM | - |
| STW | - |
| NWO Other | - |
| Industry | 75 % |
| TNO | - |
| GTI | - |
| EU | - |
| Scholarships | - |

START OF THE PROJECT

2010

INFORMATION

RAWM Henkes
015 278 1323
R.A.W.M.Henkes@tudelft.nl

Experimental set-up.

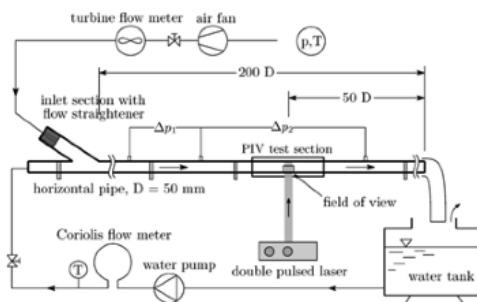

PERFORMANCE OF FOAMERS FOR DELIQUIFICATION OF GAS WELLS

PROJECT LEADERS

RAWM Henkes, LM Portela

RESEARCH THEME

Complex structures of fluids

PARTICIPANTS

D van Nimwegen

COOPERATIONS

NAM/Shell

FUNDED

NAM

University 25 %

FOM -

STW -

NWO Other -

Industry 75 %

TNO -

GTI -

EU -

Scholarships -

START OF THE PROJECT

2010

INFORMATION

RAWM Henkes

015 278 1323

R.A.W.M.Henkes@tudelft.nl

PROJECT AIM

This project is a combined experimental/modeling study on the performance of foamers for deliquification of gas wells as used in the gas and oil industry. The reduction of the reservoir pressure for maturing fields will cause that gas wells will start to accumulate liquid (water, condensate). The use of proper foamer chemicals will mix the liquid and gas into a foam, which decreases the hydrostatic head in the well and re-establishes the flow. The study includes flow experiments using a 12 m, 5 cm diameter facility.

PROGRESS

The experiments in the flow facility were continued. The influence of surfactants on the flow pattern map for vertical air-water flow was determined at two different surfactant concentrations. Three different surfactants were used in the experiments, showing a great qualitative similarity in the results. Furthermore, it was found that the critical micelle concentration of the surfactants cannot be used to predict the required dose rate of the surfactants. The existing flow facility was expanded with two additional tubes. The first has a diameter of 34 mm, and is also 12 m in length. It is mounted on the same frame as the original setup, and can therefore be inclined. The second has an 80 mm diameter, and a length of 18 meters. It is mounted on a separate frame, and cannot be inclined. Both new setups have automated gas and liquid flow control. Initial results in the 34 mm pipe show similar results as for the 50 mm pipe.

DISSERTATIONS

SCIENTIFIC PUBLICATIONS

1. Nimwegen, AT van, Portela, L & Henkes, RAWM (2013). The effect of surfactants on upward air-water flow at different pipe inclinations. In Moo Hwan Kim (Ed.), USB stick (pp. 1-12). Jeju, Zuid Korea: s.n..
2. Nimwegen, AT van, Portela, L & Henkes, RAWM (2013). The Effect of Surfactants on Vertical Air/Water Flow for Prevention of Liquid Loading. In s.n. (Ed.), Cd International Symposium on Oilfield Chemistry (pp. 1-15). The Woodlands, TX, USA: Society of Petroleum Engineers.



$D = 34 \text{ mm}$



$D = 50 \text{ mm}$



$D = 80 \text{ mm}$

MODELLING THE INFLUENCE OF FLOW ON ASPHALTENE AGGLOMERATION AND DEPOSITION

PROJECT AIM

Asphaltenes are heavy organic deposits that can be formed when the oil transport from subsurface reservoirs undergoes a sharp drop in pressure. This can be at the inflow sections from the reservoir into the well bore, or inside the wellbore, pipeline, or downstream facilities. For example injection of chemicals can help to prevent blockage of the production system. Models are used for the design of asphaltene prediction, which in turn are used for the design of deposition prevention and remediation methods. Models used so far in the oil and gas industry are highly empirical. The aim of the present project is to better understand the fundamentals of the influence of flow on the agglomeration and deposition process of asphaltenes. This will result into both new detailed flow models, as well as into improved models that can be used in the industry.

PROGRESS

The primary particle based agglomeration and break-up model implemented last year was extended such that break-up of agglomerates can be considered as a function of the four principal modes of induced stress in the inter-particle bonds: straining, shearing, bending and torsion. Simulations were conducted for all modes of break-up, at multiple Reynolds numbers, both considering one- and two-way coupling. In all cases considered, scaling relations for the mean agglomerate mass with the strength of the inter-particle bonds and the Reynolds number were obtained, yet with different scaling exponents for different break-up modes. The structure of agglomerates (form factor, fractal dimension, ...) on the other hand, to large extent is invariant to the strength of the inter-particle bonds, the break-up mode and the Reynolds number. Currently, the model is being extended with a deposition module, in which also re-entrainment of particles into the flow will be taken into account.

DISSERTATIONS

-

SCIENTIFIC PUBLICATIONS

1. K.C.J. Schutte, L.M. Portela and R.A.W.M. Henkes. A Numerical Study on the Formation and Break-up of Particle Agglomerates. 8th International Conference on Multiphase Flows, paper 731, 2013.

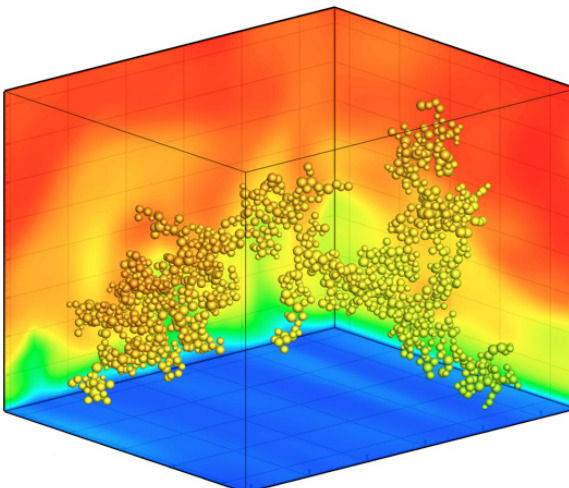

PROJECT LEADERS

RAWM Henkes, LM Portela,
A Twerda

RESEARCH THEME

Mathematical and computational
methods for fluid flow analysis

PARTICIPANTS

K Schutte

COOPERATIONS

TNO, ENI (ISAPP2)

FUNDED

| | |
|--------------|------|
| ENI | |
| University | 25 % |
| FOM | - |
| STW | - |
| NWO Other | - |
| Industry | 75 % |
| TNO | - |
| GTI | - |
| EU | - |
| Scholarships | - |

START OF THE PROJECT

2011

INFORMATION

RAWM Henkes

015 278 1323

R.A.W.M.Henkes@tudelft.nl

Snapshot of agglomerate formed
in turbulent flow (shown in
background).

THE INFLUENCE OF THE PROPERTIES OF ANTIFOULING COATINGS ON THE SKIN FRICTION AND TURBULENT BOUNDARY LAYER ALONG A SHIP

PROJECT LEADERS

WP Breugem, J Westerweel

RESEARCH THEME

Complex dynamics of fluids

PARTICIPANTS

HOG Benschop, WP Breugem,
J Westerweel

COOPERATIONS

We are part of a consortium consisting of 19 university groups, technology institutes and companies spread over Europe.

FUNDED

EU/FP7/OCEAN.2013.3 program

University -

FOM -

STW -

NWO Other -

Industry -

TNO -

GTI -

EU 100 %

Scholarships -

START OF THE PROJECT

2013

INFORMATION

HOG Benschop

015 278 6656

h.o.g.benschop@tudelft.nl

<http://www.pe.tudelft.nl/node/794>

PROJECT AIM

This project is part of the European FP7 SEAFRONT program with the aim to develop environmentally benign antifouling coatings for ships. The specific goal of this PhD project is to develop fundamental understanding of the influence of the antifouling coating properties on the skin friction and the turbulent boundary layer along a ship. To this purpose Direct Numerical Simulation will be used to study the influence of the surface texture of a coating on the structure and dynamics of turbulence. In a later stage detailed experiments will be performed in our water tunnel on the turbulent boundary layer over various antifouling coatings developed within this program.

PROGRESS

The PhD project has started in Jan 2014. Currently a literature study is made to obtain an overview of strategies for reducing the skin friction of a turbulent boundary layer.

DISSERTATIONS

-

SCIENTIFIC PUBLICATIONS

-

PROJECT AIM

Cavitating vortices trailing from a ship propeller are a source of inboard noise and vibration. When these vortices flow past rudders they could induce severe erosion. Ideally these harmful results should be prevented in the design stage. To be able to quantify sound emission and erosion more understanding is needed of the dynamics of cavitating vortices. Therefore the aim of this project is to first study the dynamics and sound emission of a cavitating vortex in isolation. Second is the study of the interaction of multiple vortices possibly near a surface. The final goal is to recreate the flow of a cavitating tip vortex past a rudder and determine its erosive properties.

PROGRESS

Tip vortices are flow structures with concentrated vorticity which can persist far downstream of a propeller. A simplified case of a cavitating vortex trailing the tip of a stationary blade at incidence is studied. High speed video recordings combined with force and acoustic measurements have been used to better understand the dynamics that consist of waves on the interface between liquid and water vapour. Comparison to an analytic model of tip vortex cavity core vibrations has provided insight in the presence of different wave modes and their transport.

DISSERTATIONS

-

SCIENTIFIC PUBLICATIONS

-

PROJECT LEADERS

TJC van Terwisga, J Westerweel,
R Delfos

RESEARCH THEME

Complex dynamics of fluids

PARTICIPANTS

PC Pennings

COOPERATIONS

Part of the International Institute for Cavitation Research (IICR), cooperation with the Dynamics of Vortex Cavitation on Ship and Pump Impellers (DYNVOR) and the STW Ship Drag Reduction projects

FUNDED

Entirely funded by the Lloyd's Register Educational Trust

| | |
|--------------|-------|
| University | - |
| FOM | - |
| STW | - |
| NWO Other | - |
| Industry | 100 % |
| TNO | - |
| GTI | - |
| EU | - |
| Scholarships | - |

START OF THE PROJECT

2011

INFORMATION

PC Pennings
015 278 8351
p.c.pennings@tudelft.nl
pe.tudelft.nl

STUDY OF DROPLET DYNAMICS AND TURBULENCE MODIFICATION IN TWO-PHASE FLOWS BY MEANS OF DNS

PROJECT LEADERS

BJ Boersma, WP Breugem

RESEARCH THEME

Complex dynamics of fluids

PARTICIPANTS

M Kwakkel, WP Breugem,
BJ Boersma

COOPERATIONS

-

FUNDED

| | |
|--------------|------|
| TU Delft | |
| University | 100% |
| FOM | - |
| STW | - |
| NWO Other | - |
| Industry | - |
| TNO | - |
| GTI | - |
| EU | - |
| Scholarships | - |

START OF THE PROJECT

2008

INFORMATION

WP Breugem
015 278 8663
w.p.breugem@tudelft.nl
<http://www.pe.tudelft.nl/269>

PROJECT AIM

The goal of this project is the understanding of droplet dynamics and turbulence modification in the clustering regime ($St \sim 1$). Droplets whose characteristic size is significantly larger than the Kolmogorov length scale are considered, whence they can not be modeled as point droplets. Situations leading to breakup and coalescence of these droplets are of particular interest. Finally Direct Numerical Simulation of a turbulent channel flow with a large number of droplets will be performed.

PROGRESS

At the DLES9 conference in Dresden in April 2013, results have been presented of a preliminary simulation of DNS of turbulent bubbly downflow in a vertical channel. The DNS was based on the multiple-marker Coupled Level-Set/Volume-of-Fluid (CLSVOF) method developed in this project. In 2013 a paper has been published in J. Comput. Phys. on the extension of the multiple-marker CLSVOF method with a physical model for coalescence and breakup of droplets. The coalescence model is based on a computationally efficient film drainage model, which predicts if and when two colliding droplets will coalesce. Simulations have been performed for the (near) head-on collision of two equal droplets in gas at four different Weber numbers (from 2.3 till 61.4), corresponding to four different collision regimes. The results are in good agreement with experimental data from literature.

DISSERTATIONS

-

SCIENTIFIC PUBLICATIONS

1. M. Kwakkel, W.-P. Breugem and B.J. Boersma. Extension of a CLSVOF method for droplet-laden flows with a coalescence/breakup model. J. Comput. Phys., 253:166-188, 2013.

MODELLING AND EXPERIMENTS FOR BY-PASS PIGGING WITH SPEED CONTROL

PROJECT AIM

A Pipeline Inspection Gauge (pig) is a cylindrical device that fits onshore or offshore pipelines for the transport of gas, oil, water in the oil and gas industry. The pig is launched at the inlet and received at the outlet. It is used for various purposes, such as water removal to prevent corrosion, removal of wax deposition along the pipe walls, removal of other solids, and inspection of the pipe wall condition. The use of a pig with an opening in the centre (a so-called by-pass pig) will allow some of the fast moving gas to flow through the pig during the pigging operation. The aim of this PhD project is to develop an optimum way to control the speed of the by-pass pig (for example by increasing/decreasing the by-pass opening depending on the local wall friction in the pipeline). This will require to carry out lab and field experiments as well as modelling using various levels of complexity (e.g. 1D pipeline models, 3D CFD for the local two-phase flow behaviour).

PROGRESS

The PhD project has started in Oct 2013. Currently a report is written with an overview of the pig physics, field applications and available literature. Based on this a detailed research plan will be made.

DISSERTATIONS

-

SCIENTIFIC PUBLICATIONS

1. Van Spronsen, G., Entaban, A., Mohamad Amin, K., Henkes, R., Field experience with by-pass pigging to mitigate liquid surge, Proc. 16th Int. Conf. on Multiphase Production Technology, BHR Group, pp. 299-308, 2013.

PROJECTLEADERS

RAWM Henkes, WP Breugem

RESEARCHTHEME

Complex dynamics of fluids

PARTICIPANTS

MHW Hendrix, RAWM Henkes,
WP Breugem

COOPERATIONS

-

FUNDED

Shell Global Solutions International
BV
University -
FOM -
STW -
NWO Other -
Industry 100 %
TNO -
GTI -
EU -
Scholarships -

START OF THE PROJECT

2013

INFORMATION

MHW Hendrix
015 278 2861
m.h.w.hendrix@tudelft.nl
<http://www.pe.tudelft.nl/node/768>

PROJECT LEADERS

J Westerweel

RESEARCH THEME

Complex dynamics of fluids

PARTICIPANTS

S Drost, J Westerweel, SJ Picken,
MT Kreutzer

COOPERATIONS

Teijin Aramid B.V.

FUNDED

| | |
|--------------------|------|
| Teijin Aramid B.V. | |
| University | 40 % |
| FOM | - |
| STW | - |
| NWO Other | - |
| Industry | 60 % |
| TNO | - |
| GTI | - |
| EU | - |
| Scholarships | - |

START OF THE PROJECT

2011

INFORMATION

S Drost
s.drost@tudelft.nl

PROJECT AIM

Investigate the instabilities occurring in contraction flows of viscoelastic liquids in general and liquid crystalline polymer solutions in specific. Such contraction flows are relevant in many industrial extrusion processes, such as fiber spinning. Ultimately, the instabilities should be controlled, leading to increased process efficiency.

PROGRESS

Studied the stability of 100:1 planar contraction flows of a liquid crystalline aramid solution and of a model fluid (PEG-PEO Boger fluid). Investigated interaction effects in case of multiple outlets, for liquid crystalline solution and model fluid, mainly experimentally, but also numerically. Currently working on a 3D set-up to study interaction effects in model fluid.

DISSERTATIONS

-

SCIENTIFIC PUBLICATIONS

1. S. Drost and J. Westerweel. Hele-Shaw Rheometry. *Journal of Rheology*, 58 (6): 1787-1802, 2013.

DEVELOPMENT OF LONG-RANGE MICRO-PIV FOR HIGH REYNOLDS NUMBER TURBULENCE

PROJECT AIM

The long-range microscopic PIV technique has been proposed in the last years to examine microscopic flow phenomena in macroscopic flows such as boundary layers and jets at high Reynolds numbers. The first goal is to implement this technique in our high pressure vessel to measure jet flow. The main aim is then to measure and characterize the small scale in this turbulent flow such as occurring in the interface between turbulent and non-turbulent flow region.

PROGRESS

Long-range microscopic PIV was performed in the fully developed region of an air jet at high Reynolds number. The measurement was performed along the centerline of the jet, where the Kolmogorov length scale (η) is estimated to be 55 μm . A vector spacing of 1.5η allowed the fine scales of turbulence to be confidently resolved. The structures of intense vorticity were found to organize themselves in the shape of elongated vortices (the so called worms), with a characteristic diameter of 10η . Adjacent to the intense vortices, the regions of intense dissipation exhibit a preferential tendency to appear. They were found to assume a sheet-like shape, with a characteristic thickness of approximately 10η . Furthermore, the jpdf of the two invariants of the reduced velocity gradient tensor (VGT) exhibits the characteristic teapot-shape that could be found in other turbulent flows. The asymmetric distribution of the jpdf is an evidence for the amplification of enstrophy on average, and for the predominance of vortex stretching. These results are in agreement with previous numerical and experimental studies at lower Reynolds number, and are collected in a manuscript, in view of an upcoming submission to a scientific journal. The final report for the sponsor (EU) of the project was produced and delivered.

With the aim of investigating the role of the large-scale gradients in modulating the small scales of turbulence both in amplitude and in frequency, an experimental campaign was carried out with hot-wire anemometry. The data have still to be processed.

DISSERTATIONS

-

SCIENTIFIC PUBLICATIONS

1. D. Fiscaletti, G.E. Elsinga, B. Ganapathisubramani, J. Westerweel. "Amplitude and frequency modulation of the small scales in a turbulent jet". In: 8th international symposium on turbulence and shear flow phenomena. Poitiers, France, August 28-30 2013.
2. D. Fiscaletti, G.E. Elsinga, J. Westerweel. "Long-range micro-PIV in the turbulent region of a jet, at high Reynolds numbers". In: 10th international symposium on particle image velocimetry – PIV13. Delft, The Netherlands, July 1-4 2013.

PROJECT LEADERS

J Westerweel, GE Elsinga

RESEARCH THEME

Complex dynamics of fluids

PARTICIPANTS

D Fiscaletti

COOPERATIONS

Universitaet der Bundeswehr
Muenchen

FUNDED

| | |
|--------------|-------|
| EU | |
| University | - |
| FOM | - |
| STW | - |
| NWO Other | - |
| Industry | - |
| TNO | - |
| GTI | - |
| EU | 100 % |
| Scholarships | - |

START OF THE PROJECT

2011

INFORMATION

D Fiscaletti

D.Fiscaletti@tudelft.nl

www.pe.tudelft.nl/Chairs/FM

THE INFLUENCE OF THE PROPERTIES OF ANTIFOULING COATINGS ON THE SKIN FRICTION AND TURBULENT BOUNDARY LAYER ALONG A SHIP E TURBULENT SEDIMENT TRANSPORT

PROJECT LEADERS

WP Breugem, BJ Boersma,
J Westerweel

RESEARCH THEME

Complex dynamics of fluids

PARTICIPANTS

PS Costa, WP Breugem,
BJ Boersma, J Westerweel

COOPERATIONS

-

FUNDED

FCT, The Portuguese Foundation for
Science and Technology
University -
FOM -
STW -
NWO Other -
Industry -
TNO -
GTI -
EU -
Scholarships 100 %

START OF THE PROJECT

2013

INFORMATION

PS Costa
015 278 4194
P.SimoesCosta@tudelft.nl
<http://www.pe.tudelft.nl/node/663>

PROJECT AIM

The aim of this PhD project is two-fold: 1) develop a state-of-the-art computational method for fully resolved simulations of dense particle-laden turbulent flows and 2) study the structure and dynamics of these flows with the developed method.

PROGRESS

We are finalizing a manuscript that addresses the development of a physically realistic and computationally efficient model for oblique particle-particle/wall collisions in viscous liquids. In parallel, we are running the first interface-resolved simulations of turbulent particle-laden channel transport.

DISSERTATIONS

-

SCIENTIFIC PUBLICATIONS

-

IMPACT OF BOILING LIQUID ON FLUID-VAPOUR-WALL INTERACTION IN LNG TRANSFER SYSTEMS

PROJECT AIM

To investigate and understand the significant flow-mechanisms occurring in a cryogenic flow through a corrugated hose. The large increase in pressure-drop in such flows is not understood yet, and we aim to be able to predict the pressure-drop and determine why. This might help optimize the transport-hose geometry.

PROGRESS

In ambient ribbed flow a relation between flow-losses and peaks in the frequency-spectrum have been found. This is a function of geometry only. Earlier measurements showed a significant increase of pressure-losses with decreases absolute system pressure.

DISSERTATIONS

-

SCIENTIFIC PUBLICATIONS

1. Conference proceedings ExHFT 8 (june 2013): The influence of cavitation on turbulent ow through a ribbed geometry.

PROJECTLEADERS

J Westerweel

RESEARCHTHEME

Complex dynamics of fluids

PARTICIPANTS

-

COOPERATIONS

-

FUNDED

University -

FOM -

STW -

NWO Other -

Industry -

TNO -

GTI -

EU -

Scholarships -

START OF THE PROJECT

-

INFORMATION

J Westerweel

015 278 9111

j.westerweel@tudelft.nl

PROJECT LEADERS

DSW Tam

RESEARCH THEME

Complex dynamics of fluids

PARTICIPANTS

G Quaranta

COOPERATIONS

Dr. M.E. Aubin, Kavli Institute Delft

FUNDED

| | |
|--------------|-------|
| University | 100 % |
| FOM | - |
| STW | - |
| NWO Other | - |
| Industry | - |
| TNO | - |
| GTI | - |
| EU | - |
| Scholarships | - |

START OF THE PROJECT

2013

INFORMATION

D TAM

015 278 2991

D.S.W.Tam@tudelft.nl

PROJECT AIM

Unraveling, through experimental study, the minimal physical mechanisms necessary to achieve spontaneous beating and synchronization of cilia. This is obtained by dynamically interacting with flagellated micro-organisms (algae *C. Reinhardtii*) in real time, by generating an external mechanical forcing in the relevant force range and at the relevant length and time scales. These experiments will answer the long standing question of whether cilia can synchronize via hydrodynamic interactions only.

PROGRESS

The project investigation has started in May. A few months have been dedicated to improve the experimental setup and to calibrate some components (i.e. voltage controlled piezoelectric stage, high speed camera control interface). Moreover, relevant to the project is the effective growth of algae used for the experiments, that has been achieved. Some preliminary results have been collected confirming the hypothesis that synchronization of the organism with an external oscillator can be induced by hydrodynamics interaction only. This results has to be verified by systematic experiments.

DISSERTATIONS

-

SCIENTIFIC PUBLICATIONS

1. Kurtuldu, H., Tam, D., Hosoi, A. E., Johnson, K. A., & Gollub, J. P. (2013). Flagellar waveform dynamics of freely swimming algal cells. *Physical Review E*, 88(1), 013015.

COHERENT STRUCTURES IN TURBULENT TAYLOR-COUPETTE FLOW

PROJECT AIM

The aim of the project is to experimentally investigate the instantaneous flow structures in turbulent Taylor-Couette flow. In combination with torque measurements, tomographic PIV will be used to measure the 3D velocity fields of coherent turbulent structures and their influence on torque change at constant shear rate. The details of the coherent turbulent flow structures that are responsible for the reported change of the torque will be studied.

PROGRESS

Time-resolved tomographic PIV measurements were performed in fully turbulent Taylor-Couette flow at exact counter-rotation of the cylinders, where the mean velocity in the Taylor-Couette gap is zero. The time-resolved measurements enabled to track turbulent flow structures over space and time to study their evolution quantitatively. Several instantaneous events, such as azimuthal velocity bursts, formation and the break-up of the turbulent flow structures, as well as hairpin formation were observed.

DISSERTATIONS

-

SCIENTIFIC PUBLICATIONS

1. Tokgoz S., Elsinga G.E. and Westerweel J. 3D Evolution of Turbulent Flow Structures in Taylor-Couette. In: Proceedings of 66th American Physical Society Division of Fluid Dynamics Conference, November 24–26, 2013. Oral presentation.
2. Tokgoz S., Elsinga G.E. and Westerweel J. The life of Taylor-Couette flow structures. In: Proceedings of PIV13; 10th International Symposium on Particle Image Velocimetry, July 1–3, 2013. Oral presentation.
3. Tokgoz S., Elsinga G.E., Delfos R. and Westerweel J. Coherent structures and angular momentum transportation in Taylor-Couette flow. In: Proceedings of 18th International Couette-Taylor Workshop, June 24–26, 2013. Oral presentation.
4. Delfos R., Tokgoz S., Alidai A., Elsinga G.E. and Westerweel J. Influence of end effects on laminar Taylor-Couette flow. In: Proceedings of 18th International Couette-Taylor Workshop, June 24–26, 2013. Oral presentation.

PROJECT LEADERS

J Westerweel, GE Elsinga

RESEARCH THEME

Complex dynamics of fluids

PARTICIPANTS

S Tokgoz, GE Elsinga, R Delfos,
J Westerweel,

COOPERATIONS

TU Delft

FUNDED

| | |
|--------------|-------|
| University | 100 % |
| FOM | - |
| STW | - |
| NWO Other | - |
| Industry | - |
| TNO | - |
| GTI | - |
| EU | - |
| Scholarships | - |

START OF THE PROJECT

2012

INFORMATION

S Tokgoz
015 278 2961
s.tokgoz@tudelft.nl
www.ahd.tudelft.nl

MITIGATION OF FLOW-INDUCED VIBRATIONS IN CORRUGATED PIPES BY MEANS OF LIQUID ADDITION

PROJECT LEADERS

C Poelma, J Westerweel

RESEARCH THEME

Complex dynamics of fluids

PARTICIPANTS

AC van Ekeveld

COOPERATIONS

Shell

FUNDED

Shell

University -

FOM -

STW -

NWO Other -

Industry 100 %

TNO -

GTI -

EU -

Scholarships -

START OF THE PROJECT

2013

INFORMATION

AC van Ekeveld

06 126 44 266

a.c.vaneckeveld@tudelft.nl

<http://delftpe.nl/node/792>

PROJECT AIM

Development of physical understanding on sound mitigation in corrugated pipes, with a focus on industrial circumstances. Aimed at providing input for design purposes of corrugated risers.

PROGRESS

Start-up of the project. Literature study and design of experimental set-ups to be built.

DISSERTATIONS

-

SCIENTIFIC PUBLICATIONS

-

DRAG REDUCTION IN WATERSPORTS

PROJECT AIM

Friction of water is a large contributor to the total drag in water sports. Reducing this drag leads to higher velocities, which is all about in most water sports; Going faster! The friction can be reduced by changing the surface properties, due to coatings, which will influence the interaction between water and object. The project aim is to develop, characterize and testing specific coatings which will reduce this friction drag.

PROGRESS

The Taylor-Couette testing facility of the Laboratory for Aero- & Hydrodynamics at the Delft University of Technology proved to be useful to analyze the drag reducing effect of specific surfaces and products. The data with riblets show a similar trend and a maximum of 5% drag reduction. A rotation effect is observed for drag reducing surfaces. Self-developed coatings will be characterized and tested on their drag reducing effect.

DISSERTATIONS

-

SCIENTIFIC PUBLICATIONS

-

PROJECTLEADERS

J Westerweel

RESEARCHTHEME

Complex dynamics of fluids

PARTICIPANTS

A Greidanus, R Delfos

COOPERATIONS

InnoSportNL, DSM, TNO, MARIN

FUNDED

InnoSportNL, DSM, MARIN

| | |
|--------------|-------|
| University | - |
| FOM | - |
| STW | - |
| NWO Other | - |
| Industry | 100 % |
| TNO | - |
| GTI | - |
| EU | - |
| Scholarships | - |

START OF THE PROJECT

2010

INFORMATION

A Greidanus

015 278 2904

A.J.Greidanus@tudelft.nl

www.ahd.tudelft.nl

DIRECT NUMERICAL SIMULATION OF TURBULENT FLUIDS CLOSE TO THEIR VAPOUR-LIQUID CRITICAL POINT

PROJECT LEADERS

R Pecnik

RESEARCH THEME

Mathematical and computational methods for fluid flow analysis

PARTICIPANTS

U Sengupta, R Pecnik, BJ Boersma

COOPERATIONS

TU Delft

FUNDED

FOM

University -

FOM 100 %

STW -

NWO Other -

Industry -

TNO -

GTI -

EU -

Scholarships -

START OF THE PROJECT

2013

INFORMATION

U Sengupta

06 843 10967

u.sengupta@tudelft.nl

<http://www.pe.tudelft.nl/Chairs/ET/>

People

PROJECT AIM

Fluids close to their thermodynamic vapor-liquid critical point (CP), also called supercritical fluids, have been the subject of intensive study for a considerable period of time. However, fundamental computational studies of supercritical fluid flows, as well as compressible dense gas flows, are largely unexplored and physical phenomena related to turbulent flows are not well understood. Industrial interest in supercritical flows has been triggered by its applications as solvents in extraction processes in the chemical industry, for carbon capture and storage in combination with enhanced oil recovery, and as working fluids in thermal power plants. The highly nonlinear behavior of the thermophysical properties close to the critical point can be utilized to greatly improve the efficiencies of the aforementioned processes. The goal of the project is to study the fundamental underlying physics of compressible turbulent boundary flows close to the vapor-liquid critical point by means of large scale parallel numerical simulation.

PROGRESS

I started working on the compressible channel flow using a compressible Navier Stokes solver. The solver uses a compact finite difference in the wall normal direction, and spectral method in the streamwise and spanwise directions to compute the gradients. I have developed knowledge on Fortran, equations of state used in simulations, compact finite difference methods and have done courses in turbulence modeling in JMBC and an MPI course at EWI. I have validated a laminar flow case with constant Prandtl Number, variable viscosity and thermal conductivity. I am currently working on simulating a turbulent flow in a channel.

DISSERTATIONS

-

SCIENTIFIC PUBLICATIONS

-

FLAMELESS COMBUSTION CONDITIONS AND EFFICIENCY IMPROVEMENT OF SINGLE- AND MULTI-BURNER-FLOXTM FURNACES IN RELATION TO CHANGES IN FUEL AND OXIDIZER COMPOSITION (FLEXFLOX). PART 1A: EXPERIMENTAL STUDIES IN SINGLE-BURNER SYSTEMS

PROJECT AIM

The objective of the flexFLOX project is to investigate both experimentally and computationally the impact of changes in fuel and oxidizer composition on flameless combustion. To reach the flameless combustion regime the air (and/or fuel) streams are diluted with hot combustion products with a temperature sufficiently high for the combustion process to be stable and occurring in a distributed reaction zone. The objective of part 1a of the project is gaining fundamental understanding of the flameless regime via laser diagnostic experiments in single burner systems, in particular the Delft jet-in-hot-coflow (DJHC) burner operated with different fuels.

PROGRESS

A new set of flame luminescence measurements in the jet-in-hot-coflow burner was made. Mixtures of natural gas and hydrogen was used as jet fuel. A High-speed Intensified Camera Attachment (HiCATT) and a Photron SA1 high-speed camera were used to produce 6000 frames at a frame rate of 5 kHz and a resolution of one mega pixel. Compared to the earlier measurements, this system captures the autoignition phenomena with enhanced detail over a larger field of view and a 2.5 times higher frame rate. Again liftoff heights were computed and the new results were compared with earlier results. Both results are similar and the minor differences found are expected due to the intrinsic inaccuracies of the hardware. Work was done on the reporting of results in the form of journals papers.

DISSERTATIONS

-

SCIENTIFIC PUBLICATIONS

1. L.D. Arteaga Mendez, M.J. Tummers, D.J.E.M. Roekaerts, Effect of Hydrogen on the Stabilization Mechanism of Natural Gas jet-in-hot-coflow Flames, In: Proceedings of the European Combustion Meeting – 2013, Paper P1-16, 4 pp, June 25-28, 2013, Lund, Sweden, ISBN 978-91-637-2151-9.
2. Y. Mahmoudi, G. Sarras, L.D. Arteaga Mendez, M. Çelik, M.J. Tummers, and D.J.E.M. Roekaerts, Flame structure and stabilization mechanism of biogas flame in a jet-in-hot-coflow burner, In: Proceedings of the 8th Mediterranean Combustion Symposium, Çeşme, Izmir, Turkey, September 8-13, 2013, Paper TC-16, 12 pages, Editors: Nevin Selcuk, Federico Beretta, Mohy S. Mansour, and Andrea d'Anna. Publisher: International Centre For Heat and Mass Transfer, METU, Ankara, Turkey.
3. L.D. Arteaga Mendez, G. Sarras, E.-S. Cho, S.Y. Mahmoudi Larimi, J. Lu, W. de Jong, M.J. Tummers, E.H. van Veen and D.J.E.M. Roekaerts, Flameless combustion conditions and efficiency improvement of single- and multiburner FLOX® furnaces in relation to changes in fuel and oxidizer composition, In : Book of Abstracts, Combura Symposium, October 9-10, 2013, Maastricht, Published by Technology Foundation STW, Utrecht, The Netherlands, Pages 3-8.

PROJECT LEADERS

DJEM Roekaerts, MJ Tummers,
W de Jong

RESEARCH THEME

Complex dynamics of fluids

PARTICIPANTS

LD Arteaga Mendez, EH van Veen

COOPERATIONS

WS-Prozesstechnik, Stuttgart

TNO glass group (Celsian BV)

Tata Steel, Numeca Int., Brussels

FUNDED

Technology Foundation STW, Tata
Steel, Shell, NVV, Numeca Int., TNO
University -

FOM -

STW 80 %

NWO Other -

Industry 15 %

TNO 5 %

GTI -

EU -

Scholarships -

START OF THE PROJECT

2009

INFORMATION

LD Arteaga Mendez

015 278 2418

l.d.arteagamendez@tudelft.nl

www.cleancombustionconcepts.nl

FLEXFLOX

PART 1B: COMPUTATIONAL STUDIES OF THE JET-IN-HOT-COFLOW BURNER

PROJECT LEADERS

DJEM Roekaerts, MJ Tummerts,
W de Jong

RESEARCH THEME

Complex dynamics of fluids

PARTICIPANTS

G Sarras, Y Mahmoudi

COOPERATIONS

-

FUNDED

Technology Foundation STW, Corus,
Shell, NVV, Numeca Int., TNO

| | |
|--------------|------|
| University | - |
| FOM | - |
| STW | 80 % |
| NWO Other | - |
| Industry | 15 % |
| TNO | 5 % |
| GTI | - |
| EU | - |
| Scholarships | - |

START OF THE PROJECT

2010

INFORMATION

G Sarras
015 278 2186
g.sarras@tudelft.nl
www.et.3mE.tudelft.nl

PROJECT AIM

The objective of the flexFLOX project is to investigate both experimentally and computationally the impact of changes in fuel and oxidizer composition on flameless combustion. To reach the flameless combustion regime the air (and/or fuel) streams are diluted with hot combustion products with a temperature sufficiently high for the combustion process to be stable and occurring in a distributed reaction zone. The objective of part 1b of the project is to develop and validate computational models using the Delft Jet-in-Hot-Coflow burner as a model system.

PROGRESS

Investigations on the modeling of the flameless combustion in the Delft-Jet-in-Hot-Coflow (DJHC) burner using the transported probability density function (PDF) method in combination with Flamelet Generated Manifold tabulated chemistry were continued. These investigations concern the experiments with Dutch Natural Gas (DNG) and with DNG diluted with CO₂ or with H₂. The tabulated chemical kinetics is based on the construction of FGMs using igniting counter flow diffusion flames with detailed chemical mechanism and including differential diffusion effects. The chemistry is parametrized as a function of two mixture fractions and a reaction progress variable (3D-FGM) or as function of these three variables and enthalpy deficit (4D-FGM). This tabulation method is able to accurately capture the inhomogeneity of the oxygen concentration and temperature at the coflow inlet. In addition, numerical simulations were conducted by solving the RANS equations using Reynolds stress model (RSM) as turbulence model in combination with EDC (Eddy Dissipation Concept) and transported probability density function (PDF) as turbulent-chemistry interaction models. The DRM19 reduced mechanism is used as chemical kinetics with the EDC model. The results show that the EDC/DRM19 and PDF/3D-FGM models predict the experimentally observed decreasing trend of lift-off height with decrease of the coflow temperature. Further, although more detailed chemistry is used with EDC, the PDF model in combination with an FGM leads to results in better agreement with experiments.

DISSERTATIONS

-

SCIENTIFIC PUBLICATIONS

1. G.Sarras, M.K.Stoellinger, D.J.E.M. Roekaerts, Transported PDF simulations of the Delft Jet-in-Hot-Coflow burner based on 4D-FGM tabulated chemistry, In: Proceedings of the European Combustion Meeting – 2013, Paper P1-80, 6 pp, June 25-28, 2013, Lund, Sweden, ISBN 978-91-637-2151-9.
2. Y. Mahmoudi, G. Sarras, L.D. Arteaga Mendez, M. Çelik, M.J. Tummerts, and D.J.E.M. Roekaerts, Flame structure and stabilization mechanism of biogas flame in a jet-in-hot-coflow burner, In: Proceedings of the 8th Mediterranean Combustion Symposium, Çeşme, Izmir, Turkey, September 8-13, 2013, Paper TC-16, 12 pages, Editors: Nevin Selcuk, Federico Beretta, Mohy S. Mansour, and Andrea d'Anna. Publisher: International Centre For Heat and Mass Transfer, METU, Ankara, Turkey.
3. G. Sarras, L.D. Arteaga Mendez, S.Y. Mahmoudi Larimi, M.J. Tummerts, D.J.E.M. Roekaerts, Flame structure and lift-off height of biogas combustion in jet-in-hot coflow flame, Abstract of Work-in-Progress Poster, ICDERS, Taipei, July 28, August 2, 2013, poster #269, p. 120.

FLEXFLOX

PART 2 : INVESTIGATIONS OF A MULTI-BURNER FURNACE

PROJECT AIM

The objective of the flexFLOX project is to investigate both experimentally and computationally the impact of changes in fuel and oxidizer composition on flameless combustion. To reach the flameless combustion regime the air (and/or fuel) streams are diluted with hot combustion products with a temperature sufficiently high for the combustion process to be stable and occurring in a distributed reaction zone. The objective of part 2 of the flexFLOX project is to do experimental and computational studies of a multi-burner FLOX furnace (MEEC furnace).

PROGRESS

Experimental studies in the MEEC furnace have been continued. To resolve issues concerning the accuracy of flue gas measurements, new measurements were made using two gas analyzers and related equipment provided by Tata Steel and the gas analyzer used previously. Next, several equipment components have been upgraded. In the past, there were only two measurement points for the emission detection: regeneration flue gas and stack flue gas. In regeneration flue gas, the emissions were found to be higher. To obtain flue gas composition in each burner separately, four new measurement points have been connected with the gas analyser system. A very interesting and repeatable finding is that even though the two burner pairs are positioned symmetrically, one of the burners has significantly lower level of CO. Our self-made water-cooled emission probe has been successfully installed and a series of experiments has been carried out using this probe. The emission probe can move in the direction parallel to the flame axis, and measure along a line from one wall to just before a burner installed in the opposite wall. In a new series of experiments the equal division of cooling air between upper and lower row of cooling tubes paid attention to. It was found that changes in total cooling air flow rate have an effect on the emissions.

DISSERTATIONS

-

SCIENTIFIC PUBLICATIONS

1. E.-S. Cho, D. Shin, D. J. Lu, W. de Jong and D.J.E.M. Roekaerts, Configuration effects of natural gas fired multi-pair regenerative burners in a flameless oxidation furnace on efficiency and emissions, *Applied Energy*, 107, 25-32, 2013. <http://dx.doi.org/10.1016/j.apenergy.2013.01.035>.
2. E.-S. Cho, J. Lu, E.H. van Veen, W. de Jong, and D.J.E.M. Roekaerts, Fuel flexibility studies for flameless combustion in a furnace with multiple regenerative burners. Results of the CCC flexFLOX project, *Brandbrief*, 20, mei 2013, Technologiestichting STW, Utrecht, The Netherlands, pages 8-11.

PROJECTLEADERS

W de Jong , DJEM Roekaerts,
MJ Tummers

RESEARCHTHEME

Complex dynamics of fluids

PARTICIPANTS

ES Cho, L Jie (CSC), EH van Veen,
D Shin (Kookmin University)

COOPERATIONS

WS-Prozesstechnik, Stuttgart
TNO glass group (Celsian BV)
Tata Steel, Numeca Int., Brussels

FUNDED

Technology Foundation STW, Tata
Steel, Shell, NVV, Numeca Int., TNO
University -
FOM -
STW 80 %
NWO Other -
Industry 15 %
TNO 5 %
GTI -
EU -
Scholarships -

START OF THE PROJECT

2009

INFORMATION

W de Jong
015 278 9476
wiebren.dejong@tudelft.nl
www.cleancombustionconcepts.nl



PROJECT LEADERS

MJ Tummers, DJEM Roekaerts

RESEARCH THEME

Complex dynamics of fluids

PARTICIPANTS

HRC Rodrigues

COOPERATIONS

TH van der Meer (U Twente), S Zhu (U Twente)

FUNDED

Technology Foundation STW (CCC program), Stork Thermeq, Shell
 University -
 FOM -
 STW 80 %
 NWO Other -
 Industry 20 %
 TNO -
 GTI -
 EU -
 Scholarships -

START OF THE PROJECT

2010

INFORMATION

HRC Rodrigues
 015 278 6745
 h.r.correiarodrigues@tudelft.nl
 www.cleancombustionconcepts.nl

PROJECT AIM

This project concerns the extension of the application of High Temperature Air Combustion (HiTAC) to heavy-oil combustion processes in a boiler and is a joint project of University Twente and Delft University of Technology. To generate the knowledge needed to be able to develop and design such a boiler, experimental and computational investigations will be made of turbulent spray flames under HiTAC conditions. At TU Delft, an experimental study of spray flames of light fuel oil burning in a co-flow of hot air diluted with combustion products will provide detailed knowledge of the relations between atomization process, ignition, entrainment and burnout.

PROGRESS

In the past year detailed experimental studies have been made for spray flames of ethanol injected in coflow of cold air or of lean combustion products. As experimental techniques we used high speed camera and laser diagnostics (LDA for gas velocity, PDA for droplet size and velocity, and Coherent Anti-Stokes Raman Spectroscopy (CARS) for temperature). To extract valid CARS temperature measurements from spectra affected by the presence of the droplets along the beam path, we applied a background correction in the N₂-CARS signal. Combining the information obtained using all techniques the factors influencing spray flame structure could be identified. Trends with fuel injection pressure, with coflow oxygen concentration and temperature and with change of fuel composition, from ethanol to acetone, were studied. The experimental databases are available for model validation studies.

DISSERTATIONS

-

SCIENTIFIC PUBLICATIONS

1. H.R.C.Rodrigues, M.J. Tummers, D.J.E.M. Roekaerts, Turbulent Spray Combustion in hot-diluted co-flow, In: Proceedings of the 9th Asia-Pacific Conference on Combustion, Gyeongju Hilton, Gyeongju, Korea, 19-22 May 2013, 4 pp.
2. H.R.C. Rodrigues, M.J. Tummers and D.J.E.M. Roekaerts, Turbulent Spray Combustion of ethanol and acetone flames in flameless conditions, In: Proceedings of the European Combustion Meeting – 2013 Paper P3-80, 6 pp, June 25-28, 2013, Lund, Sweden, ISBN 978-91-637-2151-9.
3. H.R.C. Rodrigues, M.J. Tummers, E.H. van Veen, D.J.E.M. Roekaerts, CARS temperature measurements in ethanol reacting sprays in cold and hot-diluted coflow, In: Book of abstracts, 4th Workshop on the Turbulent Combustion of Sprays (TCS4), Çeşme, Izmir, Turkey, September 8, 2013, 1 page.
4. H.R.C. Rodrigues and D.J.E.M. Roekaerts, Turbulent multiphase combustion, Ercoftac Bulletin 96 (2013) pp 18-23.

PROJECT AIM

Spray flames widely used in industrial furnaces, power generation system, etc. and there is a need for computational model to predict their properties. The objective is to develop and validated accurate and efficient modeling approaches for turbulent spray combustion. The models should describe the main physical and chemical processes, notably phase change, turbulence, chemical reaction and radiation and their mutual interactions. Models will be developed for dilute spray combustion and for the coupling between dense spray and dilute spray regions.

PROGRESS

Modeling of the Delft Spray-in-Hot-Coflow (DSHC) flame was conducted. First the Eulerian-Lagrangian approach as implemented in ANSYS Fluent 14.5 was used. The spray atomization process was modeled by LISA model while the turbulence-chemistry interaction was described by steady flamelet model. Appropriate model constants and parameters were chosen based on comprehensive parameter studies. Good agreement with experimental results was achieved, especially, for the droplet dispersion. Due to the limitation of the steady flamelet model, the flame lift-off cannot be captured. Next, a Lagrangian-Lagrangian approach combining transported Probability Density Function methods with Flamelet Generated Manifolds (FGM) was used. An ethanol auto-ignition FGM table was generated with detailed chemical mechanism. Simulation results show good agreements with experimental data in general. Capability for predicting lifted off spray flame of the current modeling approach was demonstrated, although the flame lift-off was slightly over predicted. Sensitivities on different sub-models and boundary conditions were studied. A better description of the boundary conditions is crucial for the improvement of the model prediction.

DISSERTATIONS

-

SCIENTIFIC PUBLICATIONS

1. L. Ma, S. Zhu, H.R.C. Rodrigues, M.J. Tummers, T.H. van der Meer and D.J.E.M. Roekaerts, Numerical investigation of ethanol spray-in-hot-coflow flame using steady flamelet model, In: Proceedings of the 8th Mediterranean Combustion Symposium, Çeşme, Izmir, Turkey, September 8-13, 2013, Paper EGTSC-13, 13 pages, Editors: Nevin Selcuk, Federico Beretta, Mohy S. Mansour, and Andrea d'Anna. Publisher: International Centre For Heat and Mass Transfer, METU, Ankara, Turkey.
2. L. Ma, H.R.C. Rodrigues, M.J. Tummers, T.H. van der Meer and D.J.E.M. Roekaerts, Modeling of Delft ethanol jet-in-hot-coflow flame with tabulated chemistry method, In : Book of Abstracts, Combura Symposium, October 9-10, 2013, Maastricht, Published by Technology Foundation STW, Utrecht, The Netherlands, Page 34.

PROJECT LEADERS

DJEM Roekaerts

RESEARCH THEME

Mathematical and computational methods for fluid flow analysis

PARTICIPANTS

L Ma

COOPERATIONS

B Naud, CIEMAT, Madrid

FUNDED

| | |
|---------------------------|-------|
| China Scholarship Council | |
| University | - |
| FOM | - |
| STW | - |
| NWO Other | - |
| Industry | - |
| TNO | - |
| GTI | - |
| EU | - |
| Scholarships | 100 % |

START OF THE PROJECT

2012

INFORMATION

L Ma

015 278 6745

l.ma@tudelft.nl

PROJECTLEADERS

DJEM Roekaerts

RESEARCHTHEME

Complex dynamics of fluids

PARTICIPANTS

M Xie, D Roekaerts

COOPERATIONS

TNO Defence, Security and Safety

FUNDED

Centrum Ondergronds Bouwen.

Delft Cluster (Rijkswaterstaat, TNO,

TU Delft)

University 33 %

FOM -

STW -

NWO Other 34 %

Industry -

TNO 33 %

GTI -

EU -

Scholarships -

START OF THE PROJECT

2006

INFORMATION

DJEM Roekaerts

015 289 2470

d.j.e.m.roekaerts@tudelft.nl

delftpe.nl

PROJECT AIM

For a proper risk analysis of accidents in road tunnels accurate estimates of the chances and effects of these accidents is required. This project aims at contributing to a better understanding of the accident known as BLEVE, or boiling liquid expanding vapour explosion. The thermodynamic and fluid dynamic aspects, in particular of the rapid vapourisation after a sudden decrease of pressure will be investigated by a combination of modeling and experiments. The insights gained will be used in predictive models for maximum overpressure in case of an accident and will contribute to the safe evaluation of existing road tunnels and design of future ones.

PROGRESS

The risk of explosion due to rupture of a tank filled with pressurized liquefied gas (PLG) is one of the risks to be considered in the context of studies on tunnel safety. When a vessel containing liquid well above its boiling point at normal atmospheric pressure fails catastrophically a Boiling Liquid Expanding Vapour Explosion (BLEVE) can occur. In 2013 the PhD thesis reporting the results and conclusion of the project was defended. It presents a physics-based model (TUD-NET model) that can be used to predict whether or not a BLEVE will occur and to predict the strength of the shock waves when a BLEVE occurs. Compared to existing models, the TUD-NET model offers the following advantages i) a predictive model for homogeneous bubble nucleation is included. This makes it possible to predict the onset of BLEVE in an accident involving PLG tank rupture; ii) the interfacial fluxes model is based on non-equilibrium thermodynamics taking both the chemical driven force and the thermal driven force for the interfacial heat and mass transfer into account. Compared to a simpler simulation model - the TNO model -, the TUD-NET model predicts weaker shock blast and the dynamic impact of the two-phase mixture than the TNO model confirming the role of the TNO model as the most conservative model for BLEVE simulation. The combination of the simulation tools developed in this study with simulation tools for tank rupture and tunnel response provides a comprehensive simulation tool for estimating the consequences of PLG-tank rupture in a tunnel. Implementation of the TUD-NET model in a numerical solver of the three-dimensional Euler equations is needed for further validation of the model and for application to analysis of real BLEVE events, and is recommended.

DISSERTATIONS

1. Mengeng Xie, Thermodynamic and gasdynamic aspects of a boiling liquid expanding vapour explosion, PhD Thesis, Delft University of Technology, 2013, ISBN 978-90-8891-674-8.

SCIENTIFIC PUBLICATIONS

-

ULTRA RICH COMBUSTION OF HYDROCARBONS AND SOOT FORMATION (ULRICO)

PROJECT AIM

Combustion of natural gas in the range of atmospheric pressure to high pressure (up to ~6-8 bar) at globally rich conditions will be studied computationally and experimentally with the objective to identify trends in production of soot and fixed nitrogen species (HCN, NH₃) with burner design and operating conditions and to find the optimal operating conditions resulting in the lowest production of these unwanted by-products. The project is executed jointly by University Twente and TU Delft with TU Delft contributing to the modeling part.

PROGRESS

A simple semi-empirical soot model based on the soot number density and soot mass concentration was integrated in a transported PDF method for turbulent diffusion flames. The gas phase chemistry is reduced by a flamelet generated manifold (FGM) based on the mixture fraction, progress variable and enthalpy loss. To account for the radiative heat transfer, the Reynolds averaged radiative transfer equation (RTE) is solved by means of a discrete transfer method. The proposed modeling approach is applied and validated in simulations of two turbulent non-premixed methane-air flames at 1 bar and 3 bar pressure.

DISSERTATIONS

-

SCIENTIFIC PUBLICATIONS

1. Michael Stoellinger and Dirk Roekaerts, PDF modelling of soot formation in turbulent non-premixed flames using tabulated chemistry, In: Proceedings of the European Combustion Meeting – 2013, Paper P1-55, 6 pp, June 25-28, 2013, Lund, Sweden, ISBN 978-91-637-2151-9.

PROJECT LEADERS

DJEM Roekaerts

RESEARCH THEME

Complex dynamics of fluids

PARTICIPANTS

MK Stöllinger

COOPERATIONS

JBW Kok (U Twente),

MF Woolderink (U Twente)

FUNDED

STW (CCC program)

University -

FOM -

STW 80 %

NWO Other -

Industry 20 %

TNO -

GTI -

EU -

Scholarships -

START OF THE PROJECT

2010

INFORMATION

DJEM Roekaerts

015 278 2418

d.j.e.m.roekaerts@tudelft.nl

www.pe.tudelft.nl/node/427

www.cleancombustionconcepts.nl

Predicted mean temperature contours at 1 bar (long flame) and 3 bar (short flame) in the plane of axial and radial direction

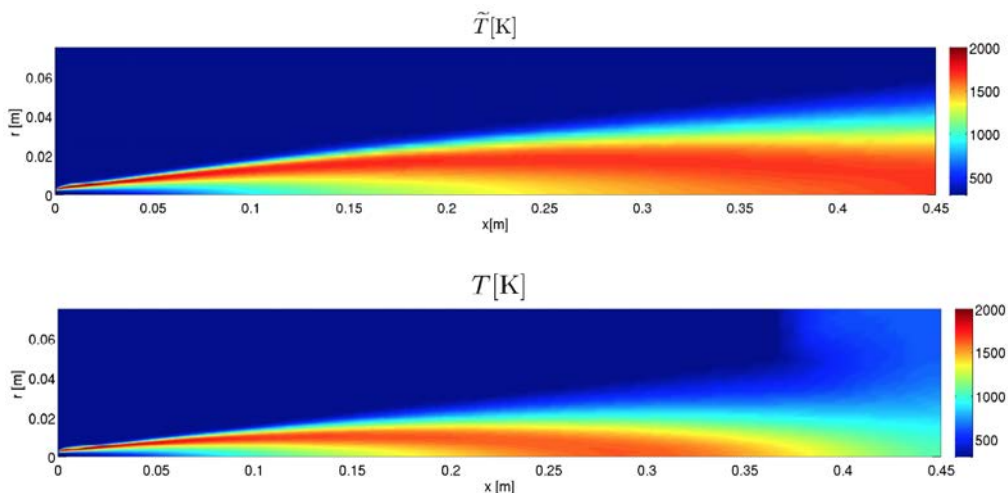

DNS MODELING OF COALESCENCE AND BREAKUP OF DROPLETS IN TURBULENT FLOW

PROJECT LEADERS

BJ Boersma

RESEARCH THEME

Mathematical and computational methods for fluid flow analysis

PARTICIPANTS

N Talebanfard, BJ Boersma,
WP Breugem

COOPERATIONS

-

FUNDED

FOM

University -

FOM 100 %

STW -

NWO Other -

Industry -

TNO -

GTI -

EU -

Scholarships -

START OF THE PROJECT

2010

INFORMATION

N Talebanfard

015 278 9111

n.talebanfard@tudelft.nl

PROJECT AIM

Developing a code for modeling flow and heat transfer over evaporating droplets by means of Direct Numerical Simulation (DNS), taking into account the deformation of droplets due to collisions and the shrinking of droplets due to evaporation by the Coupled Level Set and Volume of Fluid method (CLSVOF). The effect of the Weber number and the Reynolds number on the heat and mass transfer coefficients will be investigated.

PROGRESS

Flow and heat transfer of merging and bouncing droplets is studied for different Weber numbers, Reynolds numbers of droplets. The Navier-Stokes equations and the energy equation are solved on a staggered grid in Cartesian coordinates. Droplets are allowed to deform under the hydrodynamic forces of the surrounding flow. A coupled level-set and volume of fluid (CLSVOF) method is used to capture the highly deformable topology of the droplets. The temperature distribution inside the droplet and its consequent effect on the Nusselt number is studied. The model is validated for the case of heat transfer from a single droplet.

DISSERTATIONS

-

SCIENTIFIC PUBLICATIONS

1. Talebanfard, N., Boersma, B.J., Direct numerical simulation of heat transfer in colliding droplets by a coupled level set and volume of fluid method, Proceedings of DLES9 conference, Dresden, Germany, April 3-5, 2013.

TURBULENT FLOW AND HEAT TRANSFER NEAR THE CRITICAL POINT OF CO₂ USING DIRECT NUMERICAL SIMULATION (DNS)

PROJECT AIM

This work investigates turbulent heat transfer to a pipe flow with a fluid close to its vapour liquid critical point. The flow is simulated using Direct Numerical Simulations (DNS) of the anelastic Navier-Stokes equations at a Reynolds number of $Re = 360$, based on the friction velocity at the inlet and the diameter of the pipe. A fully developed isothermal turbulent pipe flow at subcritical conditions enters a section with a heated wall using a constant heat flux. The heat flux at the wall is chosen such that the temperature at the wall will be higher than the pseudo critical temperature. The transition of the pseudo critical temperature within the wall will cause large property fluctuation. The local effect of heat addition on turbulence, friction, buoyancy, and the heat transfer coefficient will be studied in detail.

PROGRESS

Turbulent statistics for one forced convection and two mixed convection cases with upward flow have been simulated. A decrease in turbulent kinetic energy is observed for the forced convection and the low buoyancy case, which cause heat transfer deterioration indicated by high wall temperatures. For the high buoyancy case the turbulence activity first reduces (heat transfer deterioration) followed by an increase due to turbulence recovery. For this case the wall temperature is lower than for the first two cases. Turbulent statistics are computed to highlight the effect on the observed wall temperature distribution and related heat transfer mechanisms.

DISSERTATIONS

-

SCIENTIFIC PUBLICATIONS

1. H. Nemati, B. J. Boersma & R. Pecnik "Direct numerical simulation of a turbulent flow with a supercritical fluid in a heated pipe" International Symposium On Turbulence and Shear Flow Phenomena, Poitiers.

PROJECT LEADERS

R Pecnik, BJ Boersma

RESEARCH THEME

Mathematical and computational methods for fluid flow analysis

PARTICIPANTS

H Nemati, R Pecnik, BJ Boersma

COOPERATIONS

TUD

FUNDED

Iran and TU Delft

University 50 %

FOM -

STW -

NWO Other -

Industry -

TNO -

GTI -

EU -

Scholarships 50 %

START OF THE PROJECT

2012

INFORMATION

H Nemati

015 278 1862

h.nemati@tudelft.nl

www.pe.tudelft.nl/Chairs/ET/People

EXPERIMENTAL STUDY OF TURBULENT COMBUSTION IN A SINGLE BURNER FURNACE

PROJECT LEADERS

MJ Tummers, DJEM Roekaerts

RESEARCH THEME

Complex dynamics of fluids

PARTICIPANTS

X Huang

COOPERATIONS

WS GmbH

FUNDED

China Scholarship Council

University -

FOM -

STW -

NWO Other -

Industry -

TNO -

GTI -

EU -

Scholarships 100 %

START OF THE PROJECT

2013

INFORMATION

Xu Huang

015 278 6745

x.huang-2@tudelft.nl

PROJECT AIM

The objective of the project is to get better fundamental understanding of flameless combustion. Specifically, the project aims determine the effects of fuel composition, operational conditions and nozzle geometry on the flameless combustion process in a single-burner furnace. From visualization of the reactions zones in the furnace and analysis of the flue gas composition it will be determined under which conditions the flameless combustion regime can be established in the single-burner furnace. A selected set of flames will then be studied in greater detail by measuring the velocity fields with PIV/LDA, the temperature with CARS and OH concentration with PLIF.

PROGRESS

A literature study on flameless combustion has been performed with particular emphasis on the single-burner furnaces operated by the research groups in Aachen, Adelaide and Lisbon. The design for the Delft single-burner furnace is completed. The burner is ready and has been tested outside the furnace. The furnace is currently under construction.

DISSERTATIONS

-

SCIENTIFIC PUBLICATIONS

-

CAD picture of the design of the single-burner furnace

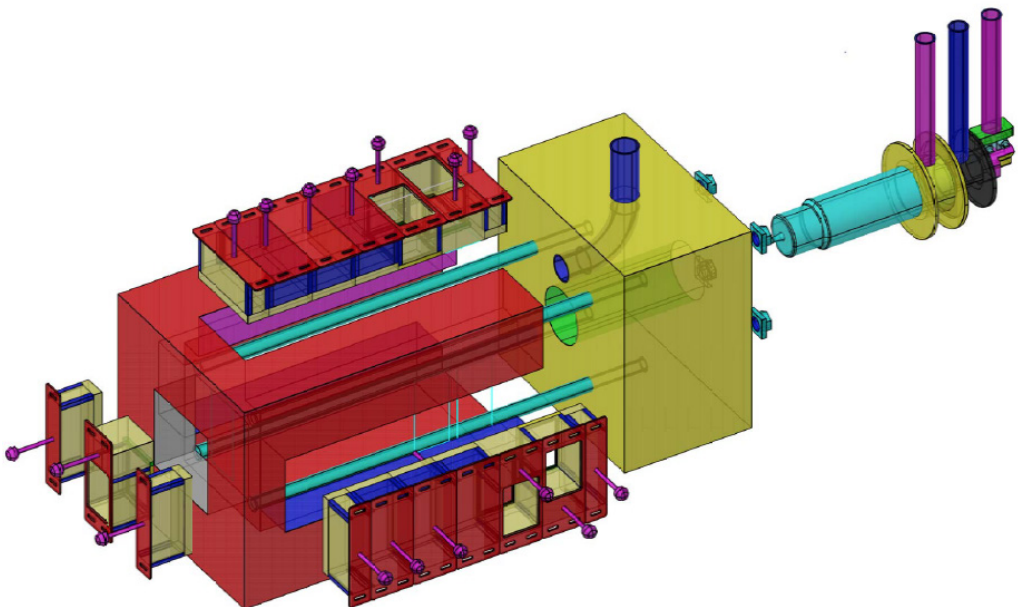



Prof.dr.ir. RHM Huijsmans



Prof.dr.ir. TJC van Terwisga

SEAKEEPING AND MANOEUVRING - PROF. RHM HUIJSMANS

Research of the Chair of Ship motions and manoeuvring is at present focused on the following areas: 1. Non-linear behaviour of fast craft in waves; 2. Extreme wave events in relation to stationary floating structures; 3. Very Large Floating Structures at sea; 4. Prediction of manoeuvring forces based on CFD methods.

High speed ships traveling in waves experience large amplitude motions which can lead to strong non-linear effects in the loads on the hull girder. These non-linear effects are due partly to the large changes in the wetted part of the hull in waves and partly due to non-linear pressure effects. Extreme wave events (breaking waves etc.) can lead to high impact loads on stationary floating structures, e.g. bow loads on Floating Production and Storage vessels for the oil industry. Hydrodynamic analysis of such behaviour is now moving towards application of CFD methods to determine the local flow at the bow. In order to simulate open sea conditions, the CFD region will be connected to an outer region which will be described by potential flow methods. This will allow waves to enter the region local to the bow and reflected waves to travel away from the bow thus minimizing reflections from the CFD boundary. Very Large Floating Structures are being investigated world-wide for various applications such as airports and for floating cities. This research is aimed at developing a novel concept of a large floating structure based on the use of air cushions to support the structure and distribute the wave loads thus optimizing both motion behaviour and structural costs. Manoeuvring models for ships have traditionally been based on equations of motions using experimentally determined drag, mass and lift coefficients. This research aims to investigate the applicability of CFD methods in determining the hydrodynamic coefficients for existing mathematical models. Use is made of a RANS code developed by MARIN and modified to accommodate oblique flow.

PROPULSION AND RESISTANCE - PROF. T VAN TERWISGA (PART TIME)

Research at the Chair of propulsion and resistance is focussed on three areas: 1. Cavitating Flows; 2. Ship-Propeller-Engine system in Service Conditions; 3. Drag reduction through air lubrication.

Cavitation remains an important field of investigation in Marine Technology. Almost all propellers in operation show cavitation in some but mostly in all working conditions. Cavitation often is an important source of vibrations and sometimes even cavitation erosion. Cavitation on propellers should therefore be controlled as much as possible in both the design and during operations. As cavitation often appears to be extremely unsteady and unstable, this poses a continuing challenge to designers and research groups. The more so because an acceptable cavitation control and a high propulsive efficiency are often conflicting requirements. The Delft Cavitation Tunnel has proven to be a strategic tool for enhancing our understanding of the physics and engineering characteristics. There are currently two PhD projects addressing this issue: One on unsteady sheet cavitation (E.J. Foeth) and another on propeller radiated pressure fluctuations (E.v.Wijngaarden). Ship-Propeller-Engine system analysis and simulation is important to reduce e.g. radiated noise from the propeller and to reduce wear of the propulsion system during its operation. To this end, a close cooperation exists with the section of Marine Engineering. There is currently a PhD project concerned with the development of a model podded propeller for testing in operational conditions (G. Oosterhuis), and a recent PhD project on improved propulsion control for Naval Vessels (A.Vrijdag). Initiatives in the third area on Drag reduction through air lubrication are currently under way.

COMFLOW-3 : EXTREME WAVE IMPACT ON OFFSHORE PLATFORMS AND COASTAL STRUCTURES

PROJECT AIM

To further improve, develop and validate the ComFLOW program for complex free-surface flows in the offshore industry and make it useable for advanced engineering applications by improved functionality and speed-up of the algorithms.

PROGRESS

All new algorithms implemented by the PhD students are merged into a code. Testing of the merged code is ongoing. Validation of all new algorithms in the code is nearing the end. These include local grid refinement, turbulence models, non-reflecting boundary condition and volume-of-fluid method. PhD students use several experiments conducted at MARIN to validate the algorithms and show the improvements compared to the previous versions of the code.

DISSERTATIONS

-

SCIENTIFIC PUBLICATIONS

1. Duz, B., Borsboom, M.J.A., Wellens, P. R., Veldman, A. E. P., and Huijsmans, R.H.M., "The effect of different volume-of-fluid (VOF) methods on energy dissipation in simulations of propagating waves", Proceedings of the 5th International Conference on Computational Methods in Marine Engineering MARINE 2013, Germany.

PROJECTLEADERS

AEP Veldman, RHM Huijsmans

RESEARCHTHEME

Mathematical and computational methods for fluid flow analysis

PARTICIPANTS

B Duz (TUDelft), HJL van der Heiden (RUG), P van der Plas (RUG), R Luppés (RUG)

COOPERATIONS

RUG, TUDelft, Marin, Deltares, Force Technology (Oslo)

FUNDED

STW, Force Technology (Oslo), Deltares, Marin, Hyundai, ABS, Gusto MSC, Aker Solutions, Chevron, Petrobras, Statoil, Conocophillips, DNV.

| | |
|--------------|------|
| University | - |
| FOM | - |
| STW | 63 % |
| NWO Other | - |
| Industry | 37 % |
| TNO | - |
| GTI | - |
| EU | - |
| Scholarships | - |

START OF THE PROJECT

2010

INFORMATION

T Bunnik
0317 49 34 29
t.bunnik@marin.nl

PROJECT LEADERS

RHM Huijsmans, JA Keuning

RESEARCH THEME

Mathematical and computational methods for fluid flow analysis

PARTICIPANTS

AAK Rijkens

COOPERATIONS

-

FUNDED

IOP Maritiem, TU Delft, Damen Shipyard Group, Ministry of Defense MARIN, Bureau Veritas, Lloyd's Register, Imtech Marine & Offshore, Quantum Controls

| | |
|--------------|------|
| University | 75 % |
| FOM | - |
| STW | - |
| NWO Other | - |
| Industry | 25 % |
| TNO | - |
| GTI | - |
| EU | - |
| Scholarships | - |

START OF THE PROJECT

2011

INFORMATION

AAK Rijkens
015 278 6872
a.a.k.rijkens@tudelft.nl
www.3me.tudelft.nl/mtt

PROJECT AIM

The aim of the PhD project is to develop an advanced ride control system for fast ships in order to improve its sea keeping behavior. The motions of these ships can be controlled by use of active flaps or interceptors located at the stern of the vessel. This project focuses on the control of these mechanisms by a proactive system that uses wave information at some distance in front of the bow. A very fast onboard simulation routine will be used to find the optimal settings of the control devices to increase the operability of the vessel in a seaway.

PROGRESS

A proactive ride control system is developed that is specifically designed to reduce the extremes in the vertical acceleration signal of a fast ship in waves. The ride control system uses an anticipatory control strategy to be able to intervene prior to a wave impact event, by adjusting the forward speed and the pitch motion of the vessel. The feasibility and performance of the proactive approach has been investigated using a dedicated ship motion simulation program. An experimental proof of concept of this proactive control system is currently being developed. Model tests will be carried out in the towing tank of the Delft University of Technology to validate the performance of this proactive control strategy.

DISSERTATIONS

-

SCIENTIFIC PUBLICATIONS

1. A.A.K. Rijkens. Improving the sea keeping behavior of fast ships using a proactive ride control system. International Conference on Fast Sea Transportation. 2013.
2. A.A.K. Rijkens, H.M.A. Cleijsen and J.A. Keuning. On the hydrodynamic performance of an improved motion control device for fast ships. International Conference on Fast Sea Transportation. 2013.



Prof.dr.ir. C van Rhee

Large volumes of sediment are displaced nowadays using different types of dredging equipment. Especially the last decade, large land reclamation projects attained global attention. Examples of these enormous projects are the new airports in Hong Kong and Singapore, the large land reclamations for ports and industry in Singapore, the spectacular projects in Dubai like the palm Islands and “the World” and the Maasvlakte II currently under construction in the Netherlands.

All Dredging processes involve slurry flows and are dominated by erosion, transport and sedimentation under special hydraulic conditions like high volumetric sediment concentration and or high flow velocity.

The research topics within the section of Dredging Engineering are focused on the physical processes encountered during dredging (and mining):

- ♦ Excavation processes of saturated sediments (mechanical, hydraulic or a combination).
- ♦ Hydraulic transportation of sediment water mixtures.
- ♦ Mixing and separation process (like the sedimentation process in a hopper of a Trailing Suction Hopper Dredge)
- ♦ Erosion and settling of sediments.
- ♦ Wear of flow components due to hydraulic transport.

MODELING OF ROCK-WATER-MIXTURES IN CUTTER SUCTION HEADS

PROJECT AIM

Current rock cutter heads spill up to 50% of the cut rock in most unfavourable conditions. Spillage can be defined as the amount of rock that is cut loose, but is not sucked up by the suction mouth. Spillage is caused by the cutting process and by the mixing process of cut rock with water in the cutter head. The goal of this research is to quantitatively describe the mixture processes of cut rock in a rotating dredge cutter head using a numerical model. With this knowledge an improved cutter head can be designed in the future or operational conditions can be changed to obtain more production.

PROGRESS

The current result of this project is a preliminary model of a rotating cutter head. With successful use of a sliding mesh approach. Furthermore velocity data of a scale model is acquired and analyzed using Fourier series.

DISSERTATIONS

-

SCIENTIFIC PUBLICATIONS

-

PROJECTLEADERS

C van Rhee, RFJ Neelissen

RESEARCHTHEME

Complex dynamics of fluids

PARTICIPANTS

GH Keetels, AM Talmon,
IK van Giffen, PJ Steinbusch,
A van Es

COOPERATIONS

Royal Boskalis Westminster,
van Oord

FUNDED

Stichting Speurwerk Baggertechniek (SSB)
University -
FOM -
STW -
NWO Other -
Industry 100 %
TNO -
GTI -
EU -
Scholarships -

START OF THE PROJECT

2012

INFORMATION

B Nieuwboer
015 278 9296
B.J. Nieuwboer@tudelft.nl

REDUCTION OF HYDROABRASIVE WEAR IN THE DREDGING INDUSTRY

PROJECT LEADERS

C van Rhee

RESEARCH THEME

Complex dynamics of fluids

PARTICIPANTS

EA Chemmalasseri, G Keetels,

AM Talmon

COOPERATIONS

Boskalis, Van Oord, IHC Merwede

MTI

FUNDED

Materials Innovation Institute

University 30 %

FOM -

STW -

NWO Other -

Industry 30 %

TNO -

GTI 40 %

EU -

Scholarships -

START OF THE PROJECT

2012

INFORMATION

EA Chemmalasseri

015 278 7430

E.A.Chemmalasseri@tudelft.nl

PROJECT AIM

Pipelines used for slurry transport in dredging applications have been observed to wear in some projects up to about 1 mm per month. On-board tubing may even wear faster. This project originates from a long-standing wish to accurately predict service life of components on dredging vessels and to prolong service life in an economic way. The scientific aim of the project is to quantify the wear rate from the actual physical wear processes, providing a scientific basis for the suggestion of methods to improve the service life of equipment for hydro transport systems in dredging.

PROGRESS

Experiments were performed to examine the viability of a slurry pipe loop as a wear test apparatus. A mounting device was used to mount the test coupon in the test channel. The wear depth was measured using the white light interferometer. The results showed that the slurry loop can be measured as a wear test apparatus.

DISSERTATIONS

-

SCIENTIFIC PUBLICATIONS

-

CFD2 PHASE

PROJECT AIM

The project aim is to numerical model the hydrodynamical behavior of water/sediment mixtures. This is done using constitutive relations, modeling sediment, and the Navier-Stokes equations. The resulting differential equations are solved using numerical techniques. The sediment fractions are described as a continuum, reducing calculation costs.

PROGRESS

The following actions have been done in 2010 : set up a numerical framework solving the Navier-Stokes equations, using the Fractional Step Method of Chorin (3D); modeling different advection schemes such as first order upwind and various fluxlimiters; modeling Turbulence using LES; literature review of modeling wallfunctions (e.g. Thin Boundary Layer Equations)

The following actions have been done in 2011 : Implemented the WALE turbulence model (LES); Added a drift flux model for modeling sand fractions of different sizes; implemented wallfunctions; implemented various other numerical schemes e.g. quick algorithm; convergence study

The following actions have been done in 2012 : Added a rheological model Bingham; Added sand viscosity Thomas; Added sedimentation; extended the drift flux model with accelerations; Compared model with experimental results sedimentation; Added penalty method for sand bed modeling.

The following actions have been done in 2013 : developed new overshootlimiter (limiting the max. packing); developed new soil model (drained/undrained behaviour); made implicit flowsolver (implicit diffusion parallel); wrote 2 conference papers and attended the conferences; performed jet experiments.

DISSERTATIONS

-

SCIENTIFIC PUBLICATIONS

1. J.C. Goeree, C. van Rhee and H.H. Bugdayci, 2013, Numerical Sediment Simulation using a Continuous Flow Model. 16th International Conference on Multiphase Production Technology, BHR Group, Cannes France.
2. J.C. Goeree and C. van Rhee, 2013, Numerical Simulation of Hydrodynamical Behaviour of Sand Water Mixtures, WODCONXX, Bruxelles Belgium.

PROJECTLEADERS

C van Rhee

RESEARCHTHEME

Mathematical and computational methods for fluid flow analysis

PARTICIPANTS

J Goeree, C van Rhee, A Talmon, G Keetels

TU Delft: C. van Rhee/A. Talmon

IHC: E. van der Blom/H. Bugdayci/H.

Van Muijen/E.A.Munts, H. Bugdayci,

Utwente: H.Hoeijmakers/N.Kruijt

COOPERATIONS

TU Delft, Utwente, AgentschapNL,

IHC Merwede BV

FUNDED

IHC Merwede BV/Agentschap NL

University -

FOM -

STW -

NWO Other 50 %

Industry 50 %

TNO -

GTI -

EU -

Scholarships -

START OF THE PROJECT

2010

INFORMATION

C van Rhee

J Goeree

015 278 3297

j.c.goeree@tudelft.nl

AN EXPERIMENTAL AND NUMERICAL STUDY OF VERTICAL HYDRAULIC TRANSPORT FOR DEEP SEA MINING APPLICATIONS

PROJECT LEADERS

C van Rhee

RESEARCH THEME

Complex dynamics of fluids

PARTICIPANTS

JM van Wijk, AM Talmon

COOPERATIONS

-

FUNDED

IHC Merwede

University -

FOM -

STW -

NWO Other -

Industry 100%

TNO -

GTI -

EU -

Scholarships -

START OF THE PROJECT

2011

INFORMATION

JM van Wijk

06 48 92 96 78

JM.vanWijk@mtiholland.com

jortvanwijk@tudelft.nl

PROJECT AIM

To assess flow assurance of the vertical hydraulic transport process, especially the risk of riser blockage is studied.

PROGRESS

- 1D 2 phase flow model ready. Navier Stokes for mixture, drift flux for transport of solids. Maximum packing limiter implemented. Wall friction for plug flow implemented.

- Axial dispersion tests in hydraulic circuit finished. Journal paper submitted to Ocean Engineering.

- Wall friction of sediment plugs experimentally investigated. Journal paper submitted to Ocean Engineering.

- Batch overtaking experiments finished. Concept journal paper being written.

DISSERTATIONS

-

SCIENTIFIC PUBLICATIONS

1. Wijk, J.M. van, Talmon, A.M. and Rhee, C. van (2013). Advances in the Modelling of Vertical Hydraulic Transport by a Continuum Approach. WODCON XX Conference, Brussels, Belgium, 3 June.

PROJECT AIM

To design a shared-control human-machine interface for controlling remotely operated deep-sea mining vehicles and other ROVs, an in-depth modeling of both the environment and human is needed. Two important parts of the environment modeling need to be addressed: the free motion control of a vehicle and its tools (grab excavator, cutter or other) at deep water depth with possible currents, and the contact interaction of the vehicle with other equipment or materials. So the aim is to numerically model the deep-sea excavation process on the seabed.

PROGRESS

Work on modeling of dense rock samples has been improved. The fluid-solid coupling mechanism has been updated. The former method which plans to handle the fluid flow in a discrete way is abandoned, instead the finite volume method (FVM) which is more fundamental and generic will be applied to simulate the fluid field in the cutting zone. It is now achieved to dynamically control the radius of the particles to reach a densely packed sample. Besides, the numerical coupling between discrete element modeling (DEM) and computational fluid dynamics (CFD) is proven to be working well in both the dilute and dense regimes via the fluidized bed simulations.

DISSERTATIONS

-

SCIENTIFIC PUBLICATIONS

1. The paper "Influence of Particle Geometry on the Simulation of Sand Cutting Process" is published by the 32nd International Conference on Ocean, Offshore and Arctic Engineering (OMAE 2013), Nantes, France. 10-14 June, 2013.
2. The paper "Porosity Calculation in Discrete Element Modeling of Sand Cutting Process" is published by the 20th World Dredging Congress (WODCON XX), Brussels, Belgium, 3-7 June 2013.

PROJECT LEADERS

SA Miedema

RESEARCH THEME

Complex structures of fluids

PARTICIPANTS

X Chen, R Kuiper, SA Miedema,
DA Abbink, FCT van der Helm

COOPERATIONS

Delft University of Technology,
Technology Foundation STW,
SeaTools B.V., Tree C Technology
B.V.

FUNDED

Technology Foundation STW
University -
FOM -
STW 100 %
NWO Other -
Industry -
TNO -
GTI -
EU -
Scholarships -

START OF THE PROJECT

2012

INFORMATION

X Chen
015 278 4697
x.chen-1@tudelft.nl

UNSTABLE BREACHING

PROJECT LEADERS

C van Rhee

RESEARCH THEME

Mathematical and computational methods for fluid flow analysis

PARTICIPANTS

D Weij

COOPERATIONS

Deltares

FUNDED

SSB, Rijkswaterstaat

University -

FOM -

STW -

NWO Other -

Industry 100 %

TNO -

GTI -

EU -

Scholarships -

START OF THE PROJECT

2013

INFORMATION

D Weij

015 278 5524

davewei@tudelft.nl

PROJECT AIM

Breaching is a gradual retreat of a sub-aqueous slope, which is steeper than the angle of repose near the top of the slope. While mainly investigated due to the application of this process in the breaching process, the breaching process can also be a cause for unwanted slope instability and failure. These failures are usually caused by unstable breaching, where the size of the retreating slope increases during the process. The aim of this project is to investigate the unstable breaching process using numerical methods. The main interest in this project is the 3D effects during the process, and the effect of large scale effects.

PROGRESS

During the last year:

- The literature was reviewed.

- An existing flow solver of OpenFOAM, based on the mixture model, was extended to include the soil modeled with a Mohr-Coulomb failure criterium.

DISSERTATIONS

-

SCIENTIFIC PUBLICATIONS

-

NUMERICAL MODELING OF DREDGE PLUMES

PROJECT AIM

The aim is to understand the complex mixing of a water-silt-sand-air plume from a dredge vessel with the ambient water. Numerical simulations are carried out for this purpose. Also scale (1:50) and field (1:1) measurements are planned. Due to the non stationary behaviour of a dredge plume the numerical approach is to use LES and not RANS. A big challenge is the large scale of the simulations with very high Reynolds numbers (up to 10 million) on relatively coarse meshes. The end goal is to find the amount of silts (fine sediments) originating from the dredge plume which stay suspended in the water column after the transition to a passive plume has taken place.

PROGRESS

- Submitted a journal papers to J. of Hydraulic Engineering
- Submitted a journal papers to Environmental Fluid Mechanics
- Writing 2 journal papers, to be submitted March 2014 to Marine Pollution Bulletin
- Writing dissertation, to be completed spring 2014

DISSERTATIONS

-

SCIENTIFIC PUBLICATIONS

1. Wit, L. de and C. Van Rhee (2013), Detailed full scale simulations of near field overflow plume mixing, Proceedings of the 20th World Dredging Conference (WODCON XX), Brussels (Belgium).
2. Radermacher, M., Van der Goot, F., Rijks, D. and Wit, L. de (2013), The Art of Screening, Effectiveness of Silt Screens, Proceedings of the 20th World Dredging Conference (WODCON XX), Brussels (Belgium).
3. Wit, L. de and C. Van Rhee (2013), Large Eddy Simulations of pulsed buoyant jet in crossflow 14th European Turbulence Conference, Lyon (France).

PROJECTLEADERS

C van Rhee

RESEARCHTHEME

Mathematical and computational methods for fluid flow analysis

PARTICIPANTS

L de Wit

COOPERATIONS

-

FUNDED

| | |
|---------------------------------|------|
| Building with Nature University | - |
| FOM | - |
| STW | - |
| NWO Other | 50 % |
| Industry | 50 % |
| TNO | - |
| GTI | - |
| EU | - |
| Scholarships | - |

START OF THE PROJECT

2008

INFORMATION

L de Wit

015 278 3583

l.dewit@tudelft.nl

PROJECT LEADERS

C van Rhee

RESEARCH THEME

Complex dynamics of fluids

PARTICIPANTS

C van Rhee, SA Miedema,
RLJ Helmons

COOPERATIONS

Industrial consortium, consisting of
Royal Dutch Shell
Royal Boskalis Westminster NV
Van Oord Dredging and Marine
Contractors BV
IHC Merwede

FUNDED

| | |
|---------------------------------|------|
| Agentschap NL (IOP Maritime) | |
| TU Delft, Industrial consortium | |
| University | - |
| FOM | - |
| STW | - |
| NWO Other | 80 % |
| Industry | 20 % |
| TNO | - |
| GTI | - |
| EU | - |
| Scholarships | - |

START OF THE PROJECT

2012

INFORMATION

RLJ Helmons
015 278 4746
r.l.j.helmons@tudelft.nl

PROJECT AIM

The goal of the project is to model the physics of the cutting process of saturated rock-like material, as is the case in dredging, trenching, (oil/gas) drilling, deep sea mining. The interaction of the hydrostatic pressure (water depth) and the pressure of the fluid in the pores of the rock is of essential influence on the failure mechanisms of rock. The model is set up through the combination of the Discrete Element Method for the solid (rock) and a Smoothed Particle Method to describe the effect of the fluid pressure in and surrounding the rock.

PROGRESS

The theoretical framework for the effects of fluid pressure on rock failure is developed. Through the use of a Darcy flow based pore-pressure diffusion equation, the effect of the fluid can be imposed on the rock. A discrete element code is developed for calculations on a GPU. On top of the discrete element framework a smoothed particle code is developed. Coupling of both methods for the solid fluid interaction is realized. The model predicts qualitatively what is expected from the theory. In the next year, the model will be validated quantitatively.

DISSERTATIONS

-

SCIENTIFIC PUBLICATIONS

1. R.L.J. Helmons, S.A. Miedema, "Cutting through hard rock-like materials, a review of the process". In WODCON XX: The art of dredging.
2. R.L.J. Helmons, S.A. Miedema, "Rock cutting for deep sea mining: an extension into poromechanics". In Poromechanics V: pp 2381-2390.



Prof.dr.ir. C Vuik

The research program of the Numerical Analysis group of TUD belongs to the field of computational science and engineering. We concentrate on the development and application of computing methods to the applied sciences. The focus is on mathematical models relying heavily on partial differential equations, such as occur in fluid dynamics. But we also consider similar mathematical models arising in other fields, for instance materials science and reservoir engineering, usually in cooperation with domain experts. A speciality is problems involving partial differential equations with moving internal boundaries, such as occur in bubbly flows and in phase transition problems. To diminish computing time in large-scale applications, iterative methods for solving large systems of algebraic equations are developed further, using deflation, multi-block, preconditioning and multigrid techniques.

MATHEMATICAL INVESTIGATION INTO SMOOTHNESS-INCREASING ACCURACY-CONSERVING METHODS FOR STREAMLINE VISUALIZATION

PROJECT AIM

The purpose of the proposed research is the mathematical and algorithmic development of smoothness-increasing accuracy-conserving filters with application to post-processing and visualizing discontinuous Galerkin simulation results.

PROGRESS

This past year focused on the theoretical and computational viability of the SIAC filter for geometry that includes nonuniform meshes and filtering for boundaries.

DISSERTATIONS

-

SCIENTIFIC PUBLICATIONS

-

PROJECT LEADERS

JK Ryan

RESEARCH THEME

Mathematical and computational methods for fluid flow analysis

PARTICIPANTS

X Li

COOPERATIONS

University of Utah, Salt Lake City, UT

FUNDED

European Office of Aerospace Research and Development/U.S. Air Force Office of Research and Development

University 20 %

FOM -

STW -

NWO Other -

Industry -

TNO -

GTI -

EU 80 %

Scholarships -

START OF THE PROJECT

2009

INFORMATION

JK Ryan

015 278 8755

J.K.Ryan@tudelft.nl

<http://ta.twi.tudelft.nl/NW/users/ryan/>

PROJECT LEADERS

C Vuik, A Segal

RESEARCH THEME

Complex dynamics of fluids

PARTICIPANTSC Vuik, A Segal, JM Tang,
R Nabben**COOPERATIONS**TU Eindhoven, Sepra, TNO-Science
and Industry, TU Berlin**FUNDED**

TUD, TNO-TPD, BRICKS

University 25 %

FOM 25 %

STW -

NWO Other -

Industry 25 %

TNO 25 %

GTI -

EU -

Scholarships -

START OF THE PROJECT

1996

INFORMATION

C Vuik

015 278 5530

c.vuik@tudelft.nl

<http://ta.twi.tudelft.nl/users/vuik>**PROJECT AIM**

The purpose is to improve efficiency of solution methods in computational fluid dynamics, porous media flow and related applications. The DICCG (deflated preconditioned conjugate gradients) method will be developed further. The method will be generalized such that reliable termination criteria can be applied. Domain subdivision methods will be developed to make DICCG applicable.

PROGRESS

The SEPRAN code is parallelized and works efficiently on parallel platforms. More and more users are simulating with the parallel version. This leads to useful feedback in order to enhance the solver. Theoretically the deflation acceleration is compared with an additive coarse grid correction and a balancing Neumann Neumann preconditioner. It appears that the deflation method leads to the fastest convergence, whereas the work per iteration is less or equal to the other methods. Many (in)compressible Navier-Stokes equation solvers use a splitting method to solve the discretized equation. In many applications, especially in bubbly flows, the pressure equation takes most of the time to be solved. One of the reasons is the jump in the density in gas and water. Multi grid methods can be used but some difficulties remain if the size of the bubbles is very small. In this project the pressure equation is solved by the deflated ICCG method. After optimization it appears that the resulting method is 4-5 times faster than the ICCG method. We plan to make a better choice of the projection vectors and try to combine it with domain decomposition and parallel computing.

DISSERTATIONS

-

SCIENTIFIC PUBLICATIONS

1. S.P. Pereira and C. Vuik and F.T. Pinho and J. M. Nobrega. On the performance of a 2D unstructured computational rheology code on a GPU AIP Conference Proceedings, 1526 (72), Novel Trends in Rheology V, 30-31 July 2013, Zlin, Czech Republic Editors: M. Zatloukal Pages: 72-89 American Institute of Physics, New York, 2013.
2. R. Gupta and M.B. van Gijzen and C. Vuik. Efficient two-level preconditioned conjugate gradient method on the GPU. High Performance Computing for Computational Science - VECPAR 2012 10th International Conference, Kope, Japan, July 17-20, 2012, Revised Selected Papers. Editors: M. Dayde, O. Marques, K. Nakajima. Lecture Notes in Computer Science, Volume 7851 Springer, Berlin, pp. 36-49, 2013.
3. R. Gupta and M.B. van Gijzen and C. Vuik. 3D Bubbly Flow Simulation on the GPU - Iterative Solution of a Linear System Using Sub-domain and Level-Set Deflation 2013 21st Euromicro International Conference on Parallel, Distributed and Network-Based Processing Feb. 27 2013-March 1 2013, Belfast, UK. Editors: Peter Kilpatrick and Peter Milligan and Rainer Stotzka IEEE Computer Society, Los Alamitos, pp. 359-366, 2013.
4. M. de Jong and A. van der Ploeg and A. Ditzel and C. Vuik (pdf, bibtex) Real-time computation of interactive waves using the GPU. 15th Numerical Towing Tank Symposium 2012 (NuTTS 2012), Proceedings of a meeting held 7-9 October 2012, Cortona, Italy. Editors: Volker Bertram. Curran Associates, Red Hook, pp. 106-111, 2013.

SOLUTION METHODS FOR NAVIER-STOKES PROBLEMS

PROJECT AIM

New preconditioners for the discretized Navier-Stokes equations will be developed. Parallel deflation methods will be included.

PROGRESS

The discrete Navier-Stokes equations are solved by the SIMPLE(R) iteration method. To decrease the very large number of iterations, we have proposed multigrid and Krylov accelerated versions: GCR-SIMPLE(R). The properties of these methods are being investigated for simple two-dimensional flows and three-dimensional flows in industrial glass melting furnaces. These methods are generalised to a colocated discretization and combined with the deflated multiblock approach and parallel computing. Now we try to generalize these solvers to our FEM discretization (SEPRAN) and compare our methods with the recently developed methods given by Elman, Wathen, Sylvester, Benzi, Reusken and Schilders. It appears that MSIMPLER, a new variant of SIMPLER, leads to the fastest results. We also develop a solver based on the Schur complement and multigrid. This method is scalable and leads to very good results for geophysical applications. The GCR-simple solver is also implemented and tested in MARIN software. This lead to a speed-up with a factor 5.

DISSERTATIONS

-

SCIENTIFIC PUBLICATIONS

1. C.M. Klaij and C. Vuik. SIMPLE-type preconditioners for cell-centered, colocated finite volume discretization of incompressible Reynolds-averaged Navier-Stokes equations. *International Journal for Numerical Methods in Fluids*, 71, pp. 830-849, 2013.
2. S.P. Pereira and C. Vuik and F.T. Pinho and J. M. Nobrega. On the performance of a 2D unstructured computational rheology code on a GPU AIP Conference Proceedings, 1526 (72), *Novel Trends in Rheology V*, 30-31 July 2013, Zlin, Czech Republic Editors: M. Zatloukal Pages: 72-89 American Institute of Physics, New York, 2013.
3. R. Gupta and M.B. van Gijzen and C. Vuik. 3D Bubbly Flow Simulation on the GPU - Iterative Solution of a Linear System Using Sub-domain and Level-Set Deflation. 2013 21st Euromicro International Conference on Parallel, Distributed and Network-Based Processing Feb. 27 2013-March 1 2013, Belfast, UK. Editors: Peter Kilpatrick and Peter Milligan and Rainer Stotzka IEEE Computer Society, Los Alamitos, pp. 359-366, 2013.
4. X. He and M. Neytcheva and C. Vuik. On preconditioning incompressible non-Newtonian flow problems. Delft University of Technology. Delft Institute of Applied Mathematics Report 13-07.
5. X. He and C. Vuik. Comparison of some preconditioners for incompressible Navier-Stokes equations. Delft University of Technology. Delft Institute of Applied Mathematics Report 13-10.

PROJECT LEADERS

C Vuik

RESEARCH THEME

Complex dynamics of fluids

PARTICIPANTS

C Vuik, S MacIaclan, Geenen, A Segal, P van Slingerland

COOPERATIONS

TNO-Science and Industry
Utrecht University, Septra Tufts
University USA, MARIN

FUNDED

| | |
|--|------|
| STW, TUD, TNO-Science and Industry, Nuffic-HEC, MARIN University | 25 % |
| FOM | - |
| STW | - |
| NWO Other | - |
| Industry | 75 % |
| TNO | - |
| GTI | - |
| EU | - |
| Scholarships | - |

START OF THE PROJECT

1992

INFORMATION

C Vuik
015 278 5530
c.vuik@tudelft.nl
<http://ta.twi.tudelft.nl/users/vuik>

PROJECT LEADERS

C Vuik, FJ Vermolen

RESEARCH THEME

Complex dynamics of fluids

PARTICIPANTS

D Ibrahim, FJ Vermolen, C Vuik,
WK van Wijngaarden-van Rossum

COOPERATIONS

-

FUNDED

| | |
|--------------|------|
| Deltares | |
| University | 25 % |
| FOM | - |
| STW | - |
| NWO Other | - |
| Industry | 75 % |
| TNO | - |
| GTI | - |
| EU | - |
| Scholarships | - |

START OF THE PROJECT

2007

INFORMATION

FJ Vermolen
015 278 7298
F.J.Vermolen@tudelft.nl

PROJECT AIM

Develop numerical methods for industrial flow problems.

PROGRESS

PhD-candidate Ibrahim defended his PhD-thesis on the density-enthalpy method for two-phase flow in porous media. Furthermore, analytical solutions for a model for biogrout, consisting of a system of hyperbolic partial differential equations has been developed. Next to the analytic solution, a numerical formalism capable of treating boundary conditions on complicated manifolds has been constructed successfully. The method is based on the solution of the Darcy equation on the manifold using a streamline upwinding-like technique. The novel method proves to be very robust with good accuracy properties due to the need of only a very small upwinding contribution.

DISSERTATIONS

-

SCIENTIFIC PUBLICATIONS

1. W.K. van Wijngaarden and F.J. Vermolen and G.A.M. van Meurs and C. Vuik
A mathematical model for Biogrout: Bacterial placement and soil reinforcement
Computational Geosciences, 17, pp. 463-478, 2013.
2. Application of the Level-Set Method to a Mixed-Mode and Curvature Driven Stefan Problem. D. den Ouden, F.J. Vermolen, L. Zhao, C. Vuik, and J. Sietsma.
3. On the Density-Enthalpy Method for the 2D Darcy Flow. D. Ibrahim, F.J. Vermolen, and C. Vuik.
4. Various Flow Equations to Model the New Soil Improvement Method Biogrout
W.K. van Wijngaarden, F.J. Vermolen, G.A.M. van Meurs and C. Vuik.

TWO-PHASE RESPIRATORY FLOW

PROJECT AIM

The purpose of the project is to extend the Mass Conserving Level Set method to complex domains, by a reformulation for unstructured discretisation of the flow equations, specifically to be able to model two-phase flow in the human respiratory system.

PROGRESS

The model for the evolution of the interface of the Mass Conserving Level-Set method has been extended to a discretisation on triangular control volumes, leading to a formulation with complexity that is comparable to the formulation for the Cartesian case. To be able to handle nonlinear velocity fields, the underlying advection scheme of the volume of fluid field has been modified.

DISSERTATIONS

-

SCIENTIFIC PUBLICATIONS

-

PROJECT LEADERS

C Vuiik, DR van der Heul

RESEARCH THEME

Mathematical and computational methods for fluid flow analysis

PARTICIPANTS

F Raees

COOPERATIONS

-

FUNDED

| | |
|--------------|-------|
| University | - |
| FOM | - |
| STW | - |
| NWO Other | - |
| Industry | - |
| TNO | - |
| GTI | - |
| EU | - |
| Scholarships | 100 % |

START OF THE PROJECT

2011

INFORMATION

DR van der Heul

015 278 2632

D.R.vanderHeul@tudelft.nl

PROJECT LEADERS

C Vuik, CW Oosterlee

RESEARCH THEME

Complex dynamics of fluids

PARTICIPANTS

C Oosterlee, C Vuik, D Lahaye,
A Sheikh

COOPERATIONS

TUD Chem.Tech, Philips, Shell,
NLR, TU Berlin

FUNDED

| | |
|--------------------------|------|
| SenterNovem, NLR, Nuffic | |
| University | 25 % |
| FOM | - |
| STW | - |
| NWO Other | - |
| Industry | 75 % |
| TNO | - |
| GTI | - |
| EU | - |
| Scholarships | - |

START OF THE PROJECT

2001

INFORMATION

C Vuik

015 278 5530

C.Vuik@tudelft.nl

<http://ta.twi.tudelft.nl/users/vuik>

PROJECT AIM

The aim is to develop efficient parallel iterative solvers for the Helmholtz problem. In order to estimate the layered structure of the earth crust seismic methods are used. The layer structure is used as input for porous media flow simulations.

PROGRESS

A special preconditioner has been developed, which in a special combination of Krylov subspace and multigrid methods has resulted in a hundredfold increase in computing speed for the Helmholtz equation, describing wave propagation. Application in seismics has been very successful, and has generated much interest from the oil exploration industry, especially after a comparison with an industrial code in an application to a practical problem posed by industry. For the first time, realistic three-dimensional applications become feasible. This has already been realized on a single-processor machine for medium-sized problems.

The 3D code for the seismic simulation package has been parallelized. Furthermore, a comparison with analytic solutions will be made. The fast solver technique will be generalized to a finite element discretization of the Maxwell equations, for radar simulations.

DISSERTATIONS

1. E. van 't Wout and D.R. van der Heul and H. van der Ven and C. Vuik
The Influence of the Exact Evaluation of Radiation Fields in Finite Precision Arithmetic on the Stability of the Time Domain Integral Equation Method
IEEE Transactions on Antennas and Propagation, 61, pp. 6064-6074, 2013.
2. A.H. Sheikh and D. Lahaye and C. Vuik. On the convergence of shifted Laplace preconditioner combined with multilevel deflation. Numerical Linear Algebra with Applications, 20, pp. 645-662, 2013.
3. E. van 't Wout and D.R. van der Heul and H. van der Ven and C. Vuik
Design of Temporal Basis Functions for Time Domain Integral Equation Methods With Predefined Accuracy and Smoothness. IEEE Transactions on Antennas and Propagation, 61, pp. 271-280, 2013.

SCIENTIFIC PUBLICATIONS

1. H. Knibbe and C.W. Oosterlee and C. Vuik. 3D Helmholtz Krylov Solver Preconditioned by a Shifted Laplace Multigrid Method on Multi-GPUs. Numerical Mathematics and Advanced Applications 2011 Proceedings of ENUMATH 2011 the 9th European Conference on Numerical Mathematics and Advanced Applications, Leicester, September 2011. Editors: A. Cangiani and R.L. Davidchack and E. Georgoulis and A.N. Gorbun and J. Levesley and M.V. Tretyakov. Springer, Berlin, pp. 653-661, 2013.
2. M. de Jong and A. van der Ploeg and A. Ditzel and C. Vuik. Real-time computation of interactive waves using the GPU. 15th Numerical Towing Tank Symposium 2012 (NuTTS 2012), Proceedings of a meeting held 7-9 October 2012, Cortona, Italy. Editors: Volker Bertram. Curran Associates, Red Hook, pp. 106-111, 2013.
3. 3D Helmholtz Krylov Solver Preconditioned by a Shifted Laplace Multigrid Method on Multi-GPU. H. Knibbe, C.W. Oosterlee, and C. Vuik.

NUMERICAL METHODS FOR PHASE TRANSFORMATIONS IN METALS AND ALLOYS

PROJECT AIM

Develop numerical methods for moving boundary problems and evolution of the statistical size distribution of particles.

PROGRESS

A fully finite-element based level-set method for the dissolution and growth of secondary phases in metals has been extended to model dissolution and growth of particles in multi-component alloys. Furthermore, the Slyozov-Lifschitz model for the modeling of the particle size distribution has been applied to HSLA-steels.

DISSERTATIONS

-

SCIENTIFIC PUBLICATIONS

1. D. den Ouden and A. Segal and F.J. Vermolen and L. Zhao and C. Vuik and J. Sietsma. Application of the level-set method to a mixed-mode driven Stefan problem in 2 D and 3 D Computing, 95, pp. 553-572, 2013.
2. C. Vuik . Phase Change Analysis and Jozef Stefan. J.C. Crepeau, Editor, Jozef Stefan: His Scientific Legacy on the 175-th Anniversary of His Birth Bentham Science Publishers, Bussum, The Netherlands, 2013.

PROJECTLEADERS

FJ Vermolen

RESEARCHTHEME

Complex dynamics of fluids

PARTICIPANTS

D den Ouden, FJ Vermolen, C Vuik, L Zhao, J Sietsma

COOPERATIONS

-

FUNDED

M2i (Materials, Metals Innovation)

University -

FOM -

STW -

NWO Other -

Industry 100 %

TNO -

GTI -

EU -

Scholarships -

START OF THE PROJECT

-

INFORMATION

FJ Vermolen

015 278 7298

F.J.Vermolen@tudelft.nl

<http://ta.twi.tudelft.nl/users/vermolen>

PROJECT LEADERS

F.J. Vermolen

RESEARCH THEME

Complex dynamics of fluids

PARTICIPANTS

S. Zemskov, F.J. Vermolen

COOPERATIONS

-

FUNDED

DCMat (Delft Centre of Materials)

University -

FOM -

STW -

NWO Other -

Industry 100 %

TNO -

GTI -

EU -

Scholarships -

START OF THE PROJECT

-

INFORMATION

F.J. Vermolen

015 278 7298

F.J.Vermolen@tudelft.nl

<http://ta.twi.tudelft.nl/users/vermolen>

PROJECT AIM

Develop models and methods for the simulation of self-healing of materials.

PROGRESS

Develop models and methods for the simulation of self-healing of materials.

DISSERTATIONS

-

SCIENTIFIC PUBLICATIONS

1. S.V. Zemskov, B. Ahmad, O. Copuroglu, F.J. Vermolen. Modeling of a self-healing process in blast furnace slag cement exposed to accelerated carbonation. Journal of Physics, conference series, 410, paper 012088, 2013.

PROJECT AIM

Develop numerical methods for several problems related to health issues.

PROGRESS

A mathematical model for cell deformation has been developed. This model has been applied to the immune system where individual leukocytes deform and neutralize bacteria which enhance the infection. A paper about this model has appeared. Furthermore, an extension to the immune system has been implemented using the cell-based formalism where cells are treated as particles. Both models are semi-stochastic, involving cell division, death as stochastic processes, as well as stochastic differential equations for the displacement of the cells. Processes like diffusion are modeled using stochastic differential equations for the cells and Green's fundamental solutions for the concentrations of growth factors, nutrients, acids, etc. Next to the cell-based approach, a continuous-based model has been developed in terms of cell densities, and concentrations of chemical elements. In this model, the mechanical balance is treated such that plasticity can be modeled. This model is used to simulate contraction of burns.

DISSERTATIONS

-

SCIENTIFIC PUBLICATIONS

1. P.A. Prokharau, F.J. Vermolen, J.M. Garcia—Aznar., Numerical method for the bone regeneration model, defined within the evolving 2D axisymmetric physical domain, *Computer Methods in Applied Mechanics and Engineering*, 253, pp. 117-145 (2013).
2. F.J. Vermolen, A. Gefen, A semi-stochastic cell-based model for in-vitro infected 'wound' healing, *Journal of Theoretical Biology*, 318, pp. 68-80 (2013).
3. F.J. Vermolen, M.M. Mul, A. Gefen. A phenomenological model for chemico-mechanically induced cell shape changes during migration and cell-cell contacts, *Biomechanical Modelling in Mechanobiology*, 12-2, pp. 301-323 (2013).

PROJECTLEADERS

F.J. Vermolen

RESEARCHTHEME

Complex dynamics of fluids

PARTICIPANTS

PA Prokharau, D Koppenol,
A Gefen, FJ Vermolen

COOPERATIONS

-

FUNDED

Dutch Burns Foundation
University -
FOM -
STW -
NWO Other -
Industry 100 %
TNO -
GTI -
EU -
Scholarships -

START OF THE PROJECT

-

INFORMATION

F.J. Vermolen

015 278 7298

F.J.Vermolen@tudelft.nl

<http://ta.twi.tudelft.nl/users/vermolen>

STATE-OF-THE-ART MODELING OF MULTIPHASE FLOW IN LARGE PIPELINE SYSTEMS

PROJECT LEADERS

C Vuijk, DR van der Heul

RESEARCH THEME

Mathematical and computational methods for fluid flow analysis

PARTICIPANTS

J van Zwieten

COOPERATIONS

Shell

FUNDED

Shell

University -

FOM -

STW -

NWO Other -

Industry 100 %

TNO -

GTI -

EU -

Scholarships -

START OF THE PROJECT

2011

INFORMATION

DR van der Heul

015 278 2632

D.R.vanderHeul@tudelft.nl

PROJECT AIM

The purpose of the project is to develop a robust, efficient and accurate algorithm for the simulation of multiphase flow in large (Length \gg diameter) pipeline systems.

PROGRESS

The algorithm has been extended to include basic h-p refinement. For a number of test cases the algorithm has been shown to have excellent efficiency in terms of degrees of freedom for a given accuracy, especially in comparison with the finite volume schemes that are currently used in industry. Additionally, the problem of vanishing volume fraction of either of the comprising phases has been addressed.

DISSERTATIONS

-

SCIENTIFIC PUBLICATIONS

-

PROJECT AIM

The purpose of the project is to obtain a better understanding of the transition from stable to unstable multiphase flow in pipeline systems through numerical simulations.

PROGRESS

The function relating the volume of fluid to the level-set field that forms the heart of the Mass Conserving Level-Set method has been formulated for a cylindrical coordinate system and incorporated in an algorithm to solve the Navier-Stokes equations on cylindrical domains.

DISSERTATIONS

-

SCIENTIFIC PUBLICATIONS

-

PROJECTLEADERS

DR van der Heul

RESEARCHTHEME

Mathematical and computational methods for fluid flow analysis

PARTICIPANTS

G Oud

COOPERATIONS

-

FUNDED

SHELL, DELTARES, TNO

University -

FOM -

STW -

NWO Other -

Industry 33 %

TNO 33 %

GTI 33 %

EU -

Scholarships -

START OF THE PROJECT

2011

INFORMATION

DR van der Heul

015 278 2632

D.R.vanderHeul@tudelft.nl

MODELING AND NUMERICAL SIMULATION OF SURFACE COATING VIA THERMAL SPRAYING

PROJECT LEADERS

S Turek, M Möller

RESEARCH THEME

Mathematical and computational methods for fluid flow analysis

PARTICIPANTS

C Kühbacher, O Mierka

COOPERATIONS

TU Dortmund University

FUNDED

DFG (German Research Foundation)

University -

FOM -

STW -

NWO Other -

Industry 100 %

TNO -

GTI -

EU -

Scholarships -

START OF THE PROJECT

2011

INFORMATION

M Möller

015 278 9755

M.Moller@tudelft.nl

[http://ta.twi.tudelft.nl/nw/users/](http://ta.twi.tudelft.nl/nw/users/matthias)

matthias

PROJECT AIM

Subproject B7 of the CRC 708 "3D-Surface Engineering of Tools for Sheet Metal Forming – Manufacturing, Modeling, Machining –" at TU Dortmund, Germany. The main task of this project is the development of mathematical models, numerical simulation techniques and the implementation of software tools into the open-source software FEATFLOW, providing the basic understanding of the fluidic processes in surface coating via thermal spraying. While subproject 1 (M.Möller) is concerned with high-resolution FEM simulation techniques for compressible (particle-laden) gas flows and their efficient implementation, subproject 2 (S.Turek) focuses on the development of FEM-Level Set techniques for treating the multiphase flow models which are used for the 3D droplet dynamics.

PROGRESS

In this passed year, subproject 1 focused on the development of high-resolution finite element methods and their efficient implementation on multi-/many-core systems for the numerical simulation of axisymmetric internal and external single phase gas flows within the twin-wire arc spraying apparatus. The main objective was to design an optimized de Laval nozzle as a replacement for the existing commercial one that improves the properties of the spray jet. This research was performed in strong collaboration with colleagues from mechanical engineering. The main result of subproject 2 is the development of a novel optimization-based approach to enforce mass conservation in level-set finite element methods. Moreover, the 3D FEM-code for the numerical simulation of the droplet generation process at the tips of the brazing wires was extended to include turbulent effects, modulation and heat evolution.

DISSERTATIONS

-

SCIENTIFIC PUBLICATIONS

1. S. Hysing, S. Turek: Evaluation of commercial and academic CFD codes for a two-phase flow benchmark test case, *International Journal of Computational Science and Engineering*, in press (2013) (<http://www.inderscience.com/info/ingeneral/forthcoming.php?jcode=ijcse>).
2. M. Möller: Algebraic flux correction for nonconforming finite element discretizations of scalar transport problems, *Computing*, 95 (2013) 7, p. 425-448.



Prof.dr.ir. AW Heemink

The central research direction of the group is the mathematical modeling of physical phenomena using (partial) differential equations. The research is application driven and includes the modeling phase, analysis of the model and the numerical implementation of the model. The focus is now more and more on the research themes:

INVERSE MODELING AND DATA ASSIMILATION

Data assimilation methods are used to combine the results of a large scale numerical model with the measurement information available in order to obtain an optimal reconstruction of the dynamic behavior of the model state. Many data assimilation schemes are based on solving the Euler-Lagrange equations. A recursive algorithm to solve this two-point boundary value problem can be derived and results in the well-known Kalman filtering algorithm. Variational data assimilation is also a powerful method, but requires the implementation of the adjoint (of the tangent linear approximation) of the numerical model. In a series of externally funded PhD projects the mathematical algorithms have been developed and applied in a number of real life applications:

- Tidal flow models (funding: Rijkswaterstaat)
- Atmospheric-chemistry modeling (funding: NWO, TNO, RIVM).
- Oil reservoir modeling (Funding: Shell, TNO).

PERTURBATION METHODS FOR PARTIAL DIFFERENTIAL EQUATIONS

The main focus within this theme is to develop perturbation methods to analyse initial value problems and initial-boundary value problems for partial differential equations. The applications are in a variety of fields, such as: the wind flow (or rain-wind) induced oscillations of bridges, high-rise buildings, or of overhead power transmission lines; the vibrations of conveyor belts; and the morphodynamics in tidal embayments.

HIGH PERFORMANCE COMPUTING AND PARALLEL ALGORITHMS

This research theme aims to design efficient and scalable parallel algorithms and apply high performance computing technology to applications, such as the storm surge forecasting and pollutant transport in North Sea or rivers. Domain decomposition and grid partitioning is an effective approach for parallel simulation of models described by partial differential equations. Sparse matrices typically occur in numerical simulation of problems described by partial differential equations. One of our research focus is on designing parallel algorithms for solving sparse matrix systems. Lagrangian models, often also called particle models, for transport problems in coastal waters, can deal with steep gradients of concentration. Because the movements of the particles are largely independent from each other, so particle models are very suited for parallel and distributed computing. We have developed parallel models for transport problems of the Dutch coastal water (e.g., Wadden sea). Currently, a particle model with adaptive time steps is being developed, besides the derivation of the numerical scheme the additional challenge is to maintain a good load balance in an adaptive scheme. Grid computing is the next step of development in high performance computing.

PROJECT AIM

The research aims at the design and implementation of high performance and parallel algorithms for sparse matrix computations. The applicability and limitations of the grid computing technology will also be investigated.

PROGRESS

The research focuses on designing parallel algorithms for large scale sparse matrix computations. Multi-level parallel ensemble Kalman filter (EnKF) algorithms are currently being developed, the methods are applied to oil reservoir modelling with time-lapse seismic data. Parallelization using GPU (General-purpose graphical units) has been included in the implementation of multi-level parallel EnKF algorithms.

DISSERTATIONS

-

SCIENTIFIC PUBLICATIONS

1. Md. Khairullah, Hai-Xiang Lin, Remus G. Hanea, Arnold W. Heemink, Parallelization of Ensemble Kalman Filter (EnKF) for Oil Reservoirs with Time-lapse Seismic Data, World Academy of Science, Engineering and Technology, International Science Index 79, International Journal of Mathematical, Computational Science and Engineering (2013), 7(7): 51-59.

PROJECT LEADERS

AW Heemink, HX Lin

RESEARCH THEME

Mathematical and computational methods for fluid flow analysis

PARTICIPANTS

HX Lin, SM Xu

COOPERATIONS

Tsinghua University, China

FUNDED

| | |
|--------------|------|
| University | 70 % |
| FOM | - |
| STW | - |
| NWO Other | - |
| Industry | - |
| TNO | - |
| GTI | - |
| EU | - |
| Scholarships | 30 % |

START OF THE PROJECT

2005

INFORMATION

HX Lin

015 278 7229

H.X.Lin@tudelft.nl

<http://mathematicalphysics.ewi.tudelft.nl>

tudelft.nl

PROJECT LEADERS

AW Heemink

RESEARCH THEME

Mathematical and computational methods for fluid flow analysis

PARTICIPANTS

M Rojas, R Hanea, UM Altaf,
N van Velzen, M Verlaan,
AW Heemink, I Garcia, JC Pelc,
C Maris, S Szklarz

COOPERATIONS

Deltares, RIVM, Shell, MIT,
TNO, Vortech

FUNDED

| | |
|---------------------------|------|
| Deltares, Shell, TNO, NWO | |
| University | 10 % |
| FOM | - |
| STW | - |
| NWO Other | 10 % |
| Industry | 20 % |
| TNO | 30 % |
| GTI | 20 % |
| EU | - |
| Scholarships | 10 % |

START OF THE PROJECT

2001

INFORMATION

AW Heemink
015 278 5813
a.w.heemink@tudelft.nl

PROJECT AIM

Large scale numerical models are often used for prediction problems. These models however are however far from perfect. The model predictions can be improved by assimilating measurements into the model using a Kalman filter. A serious problem with this approach is that the standard filter algorithm imposes a very large burden on the computer. In order to obtain a computationally efficient filter, simplifications have to be introduced. Model reduction is a corner stone in developing sub-optimal scheme's. In this project new sub optimal algorithms to solve large scale Kalman filtering problems are developed.

PROGRESS

We have developed a model reduction methodology for large scale numerical models in corporation with TNO, Shell and Deltares. New PhD projects around the theme "Smart Wells" in corporation with the faculty CiTG, MIT and Shell have started. In these PhD projects we will develop and apply model reduction and filtering techniques for assimilating data into multi-phase flow models in order to solve reservoir engineering problems. New application areas are also ecological coastal sea models and morphodynamic models.

DISSERTATIONS

1. M.V. Krymskaya, Quantification of the Impact of data in reservoir engineering, PhD thesis Delft University of Technology, 2013, promotoren: A.W. Heemink and J.D. Jansen.
2. J.Pelc, Data assimilation for marine Ecosystem models, PhD thesis Delft University of Technology, 2013, promotor: A.W. Heemink.

SCIENTIFIC PUBLICATIONS

1. Towards a data assimilation system for morphodynamic modeling: bathymetric data assimilation for wave property estimation, Garcia, Ivan D.; El Serafy, Ghada; Heemink, Arnold; et al., OCEAN DYNAMICS, Volume: 63, Issue: 5, Pages: 489-505, 2013.
2. A reduced adjoint approach to variational data assimilation, Altaf, M. U.; El Gharamti, M.; Heemink, A. W.; et al., COMPUTER METHODS IN APPLIED MECHANICS AND ENGINEERING, Volume: 254, Pages: 1-13, 2013.

FLEXIBLE COMPUTATIONAL METHODS FOR TRANSPORT APPLICATIONS

PROJECT AIM

Our aim is to apply and develop flexible numerical methods for transport applications in real-life large-scale environmental studies.

PROGRESS

The study of oil spill modeling for the Persian Gulf has been finished. A new research direction is under consideration.

DISSERTATIONS

-

SCIENTIFIC PUBLICATIONS

-

PROJECT LEADERS

AW Heemink

RESEARCH THEME

Mathematical and computational methods for fluid flow analysis

PARTICIPANTS

P Wilders, MA Badri

COOPERATIONS

Deltares, Isfahan University

FUNDED

EEMCS, ISFAHAN UNIVERSITY

University 100 %

FOM -

STW -

NWO Other -

Industry -

TNO -

GTI -

EU -

Scholarships -

START OF THE PROJECT

2009

INFORMATION

P Wilders

015 278 7291

p.wilders@tudelft.nl

<http://mathematicalphysics.ewi.tudelft.nl>

tudelft.nl

PERTURBATION METHODS FOR PARTIAL DIFFERENTIAL EQUATIONS

PROJECT LEADERS

AW Heemink

RESEARCH THEME

Mathematical and computational methods for fluid flow analysis

PARTICIPANTS

WT van Horssen, HM Schuttelaars, JLA Dubbeldam, SH Sandilo, T Akkaya, N Gaiko, R Ali, M Kumar, X Wei, MAK Bulelzai

COOPERATIONS

-

FUNDED

| | |
|--------------|------|
| University | 70 % |
| FOM | - |
| STW | - |
| NWO Other | 10 % |
| Industry | 20 % |
| TNO | - |
| GTI | - |
| EU | - |
| Scholarships | - |

START OF THE PROJECT

2003

INFORMATION

WT van Horssen
015 278 3524
W.T.vanHorssen@tudelft.nl
<http://math.ewi.tudelft.nl>

PROJECT AIM

The main focus within this project is to develop and to apply perturbation methods to analyze initial value problems and (initial)boundary value problems for partial differential equations. The applications are in a variety of fields, such as: the wind or rain-wind induced oscillations of elastics structures (such as bridges, high-rise buildings, and overhead power transmission lines); the vibrations of conveyor belts and elevator cables; the morphodynamic evolution of coastal systems (such as beaches, and estuaries); and the dynamics of polymers in shear flow.

PROGRESS

In 2013 the applicability of different types of perturbation methods was investigated. For problems with boundary damping, for nonselfadjoint problems, for weakly nonlinear problems, and for problems with variable coefficients all kinds of computational aspects have been studied by using perturbation methods, methods from dynamical system theory, numerical methods, and stochastic methods.

DISSERTATIONS

1. A. Rohe, Towards parameter limits of displacement boundary value problems for Mohr-Coulomb models, TU Delft, 30 January 2013; promotor: F. Molenkamp; co-promotor: W.T. van Horssen.
2. R.L. Brouwers, Cross sectional stability of double inlet systems, TU Delft, 30 September 2013; promotor M.J.F. Stive; co-promotor: H.M. Schuttelaars.
3. M.A.K. Bulelzai, Mathematical models for atherosclerotic plaque evolution, TU Delft, 09 December 2013; promotor: A.W. Heemink; co-promotor: W.T. van Horssen.
4. S.H. Sandilo, On aspects of asymptotics for axially moving continua, TU Delft, 12 December 2013; promotor: A.W. Heemink; co-promotor: W.T. van Horssen.

SCIENTIFIC PUBLICATIONS

1. Driven translocation of a polymer: Fluctuations at work, L.J.A. Dubbeldam, V.G. Rostiashvili, A. Milchev, and T.A. Vilgis. *Phys. Rev. E* 87, 032147.
2. On constructing accurate approximations of first integrals for difference equations, M. Rafei, W.T. van Horssen. *Communications in Nonlinear Science and Numerical Simulation*, Volume 18, Issue 4, April 2013, p. 835-850.
3. Nonlinear vibrations of a beam with time-varying rigidity and mass, A.K. Abramian, W.T. van Horssen, S.A. Vakulenko. *Nonlinear Dynamics*, Volume 71, issue 1-2, January 2013, p. 291-312.
4. Improving the predictive power when modelling physical effects of human interventions in estuarine systems. H.M. Schuttelaars, V.N. de Jonge, A. Chernetsky. *Ocean & Coastal management*, Volume 79, July 2013, p 70-82.
5. Observations of barrier island length explained using an exploratory morphodynamic model, P.C. Roos, H.M. Schuttelaars, R.L. Brouwer. *Geophysical Research Letters*, Volume 40, Issue 16, August 28, 2013, p 4338-4343.
6. Residual Sediment Fluxes in Weakly-to-Periodically Stratified Estuaries and Tidal Inlets, H. Burchard, H.M. Schuttelaars, W.R. Geyer. *Journal of Physical Oceanography*, Volume 43, Issue 9, September 2013, p 1841-1861.

TRANSPORT PHENOMENA



Prof.dr.ir. CR Kleijn



Prof.dr. RF Mudde



Prof.dr.ir. HEA van den Akker



Prof.dr.S Sundaresan

The Transport Phenomena group studies the transport of mass, momentum and heat, on different length and time scales, in physical, biological and chemical processes related to advanced materials processing, energy conversion and storage, and health. The main interest is in transport phenomena around (solid-fluid, liquid-gas and liquid-liquid) interfaces, which we wish to understand, control and enhance.

The group uses both theoretical and computational models, and non-intrusive experiments based on laser and X-ray techniques.

Our expertise is in heat and mass transfer in multiphase flows, turbulent flows, microflows and biological flows.

A partial list of topics which we currently work on:

- Multiphase flow and dynamic contact line phenomena in digital microfluidics and Labs-on-Chips
- Dispersed multiphase flows in large scale chemical processing (bubble columns, fluidized beds, Fischer Tropsch)
- Magneto-hydrodynamics in advanced liquid metal processing (welding, casting)
- Magnetic drug targeting
- Oil-water separation
- Turbulence modulation for enhanced heat and mass transfer

MODELLING OF INTERFACE EVOLUTION IN ADVANCED WELDING (MINTWELD)

PROJECT AIM

The MINTWELD project aims to improve welding processes by using simulation models working on a range of length scales and knowledge gained from industrial experiments. Our contribution is to develop computational models for the prediction of the influence of hydrodynamics on the interface evolution in advanced welding processes.

PROGRESS

We have completed a software tool to predict laser welding processes, which requires the simulation of the transient flow of molten steel driven by thermocapillary forces, the dynamics of the liquid free surface as well as the heat distribution in the base metal and the final weld pool shape, both of which are highly dependent on the flow within the pool. We can also simulate arc welding processes, which additionally require the computation of the current distribution in the weld, the resulting Lorentz forces, and the inclusion of the shear exerted by the arc on the liquid pool. The code has been extensively validated against test cases from literature as well as experimental welding trials conducted at TUD-3ME. Results obtained so far demonstrate the strong influence of surfactants on the welding process and confirm the importance of surface tension differences as a main driving force. Furthermore, we have coupled our macroscale model to a mesoscale solidification model developed by our partners at University College Dublin. The combined model can predict microstructural changes during the solidification of a welded section, which have a big impact on the mechanical properties of the weld.

DISSERTATIONS

-

SCIENTIFIC PUBLICATIONS

-

PROJECT LEADERS

CR Kleijn, S Kenjeres

RESEARCH THEME

Complex dynamics of fluids

PARTICIPANTS

A Kidess, CR Kleijn, S Kenjeres

COOPERATIONS

Prof. Ian Richardson, Dr. Chuangxin Zhao (both TU Delft Materials Science and Engineering) University of Leicester; University College Dublin; University of Oxford; Norwegian Institute of Science and Technology; Royal Institute of Technology Stockholm; Ecole Polytechnique Federale de Lausanne; Tata Steel UK; TWI; Frenzak; Polish Welding Centre of Excellence

FUNDED

| | |
|--------------|-------|
| EU FP7 | - |
| University | - |
| FOM | - |
| STW | - |
| NWO Other | - |
| Industry | - |
| TNO | - |
| GTI | - |
| EU | 100 % |
| Scholarships | - |

START OF THE PROJECT

2009

INFORMATION

CR Kleijn

015 278 2835

C.R.Kleijn@TUDelft.NL

www.cheme.nl/tp

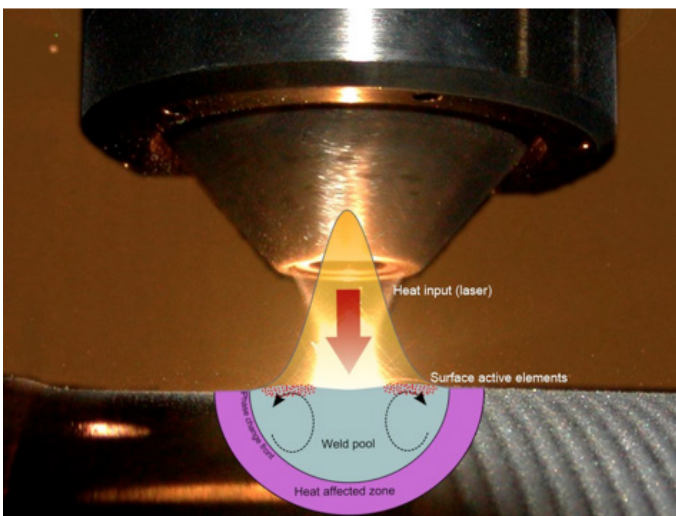

NUMERICAL FLOW SIMULATIONS ON IMPROVED CONTINUOUS CASTING THROUGH ELECTROMAGNETIC FLOW CONTROL

PROJECT LEADERS

CR Kleijn, S Kenjereš, M Tummers

RESEARCH THEME

Complex dynamics of fluids

PARTICIPANTS

B Righolt

COOPERATIONS

Tata Steel, ABB

FUNDED

STW, Tata Steel, ABB

University -

FOM -

STW 88 %

NWO Other -

Industry 12 %

TNO -

GTI -

EU -

Scholarships -

START OF THE PROJECT

2010

INFORMATION

BW Righolt

015 278 7084

b.w.righolt@tudelft.nl

PROJECT AIM

The aim of the project is to provide a fundamental understanding of, and experimentally validated models for, the influence of electromagnetic fields on flow, turbulence and heat transfer in liquid steel during continuous casting. These insights and models will make it possible to design and to optimize new strategies for controlling steel casting processes, leading to significant energy savings, increased productivity and improved product quality.

PROGRESS

An analytical model for the combined free surface and magnetohydrodynamic flow has been substantially extended with the inclusion of the gravity force, which was numerically validated using OpenFOAM (Volume of Fluid and Moving Mesh Interface Tracking method). Furthermore, the accurate modeling of the experimental facility shows the agreement with the sub-surface flow features experimentally observed, with respect to size and location of recirculation zones and the transient behavior of the free surface.

The numerical modeling of the electromagnetohydrodynamic single phase flows show excellent agreement (see figure 1) with the physical processes and flow conditions in an experimental water model and the modeling of the thermal processes in the experimental water model show promising results.

DISSERTATIONS

-

SCIENTIFIC PUBLICATIONS

-

Comparison of contours of the magnitude of the mean velocity and velocity for the numerical model (left) and experimental water model (right).

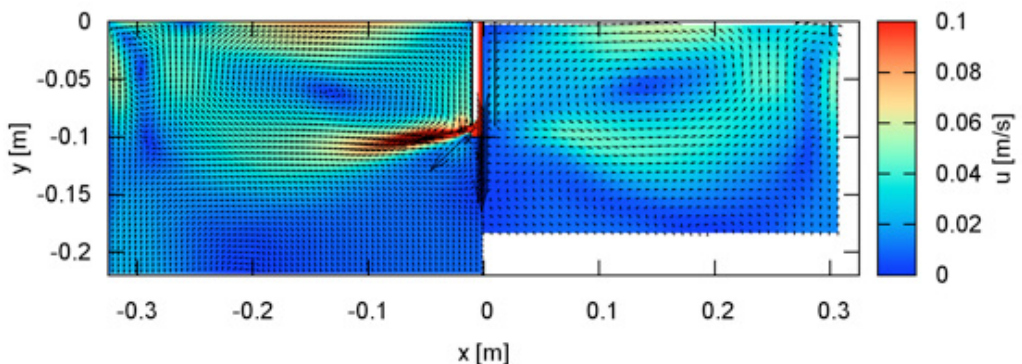

PROJECT AIM

The goal of this project is to develop predictive models for the protective behavior and thermal comfort of Nuclear-Biological-Chemical protective textiles, with a special focus on chemical breakthrough. We study air flow, heat and mass transfer through the textile at multiple scales, ranging from that of the textile fibers and carbon particles to that of an entire person, in combination with the penetration of both gaseous and liquid toxic components.

PROGRESS

We developed a computational model for flow, heat and mass transfer to a solid cylinder, mimicking a limb, sheathed by CBRN protective garment material, and exposed to a turbulent cross flow of air with a tracer amount of hazardous gas. The computational model has been successfully validated against published experimental data. The model shows that, for realistic conditions, the introduction of a single layer of carbon material with an open area fraction as large as 0.6 reduces the mass deposition of tracer gas onto the cylinder by one to three orders of magnitude, whereas heat transfer is decreased by tens of percents, thus optimizing the balance between protection and thermal comfort.

DISSERTATIONS

1. D. Ambesi, "Flow, heat and mass transfer through CBRN protective clothing", TU Delft, May 7, 2013.

SCIENTIFIC PUBLICATIONS

1. D. Ambesi and C.R. Kleijn, "Laminar-forced convection mass transfer to ordered and disordered single layer arrays of spheres", AICHE journal, 59(4), 2013, pp. 1400-1408.
2. Davide Ambesi, Richard Bouma, Emiel den Hartog and Chris R. Kleijn, "Predicting the chemical protection factor of CBRN protective garments", Journal of Occupational and Environmental Hygiene, 10 (2013), pp 270-276.

PROJECT LEADERS

CR Kleijn

RESEARCH THEME

Complex dynamics of fluids

PARTICIPANTS

D Ambesi, CR Kleijn

COOPERATIONS

TNO Defense and Security

FUNDED

| | |
|--------------|-------|
| TNO | |
| University | - |
| FOM | - |
| STW | - |
| NWO Other | - |
| Industry | - |
| TNO | 100 % |
| GTI | - |
| EU | - |
| Scholarships | - |

START OF THE PROJECT

2009

INFORMATION

CR Kleijn
 015 278 2835
 C.R.Kleijn@TUDelft.NL
 www.msp.tudelft.nl

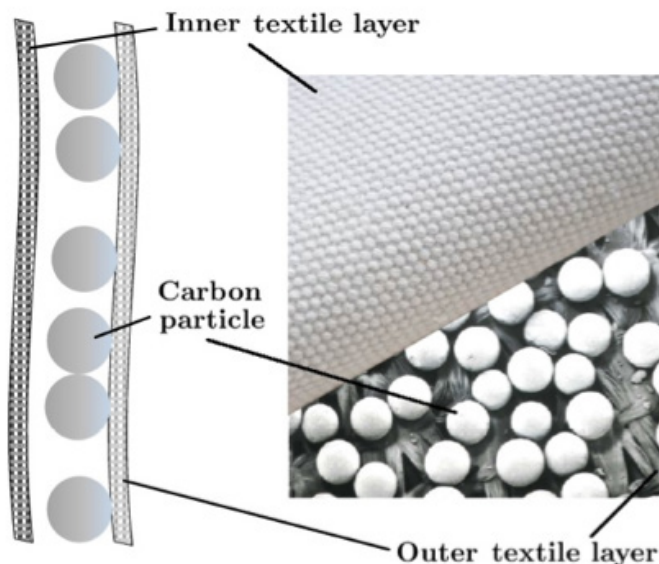

PROJECT LEADERS

CR Kleijn, MT Kreutzer

RESEARCH THEME

Complex dynamics of fluids

PARTICIPANTS

Duong Anh Hoang

COOPERATIONS

TU Eindhoven (J.C. Schouten)
Wageningen University (K. Schroen)
OSPT-IROP (DSM, Shell, DOW,
Akzo-Nobel, Unilever, TNO)

FUNDED

STW, OSPT-IROP IROP (DSM,
Shell, DOW, Akzo-Nobel, Unilever,
TNO)
University -
FOM -
STW -
NWO Other 75 %
Industry 25 %
TNO -
GTI -
EU -
Scholarships -

START OF THE PROJECT
2009

INFORMATION

CR Kleijn
015 278 2835
C.R.Kleijn@TUDelft.NL
www.msp.tudelft.nl

D Anh Hoang
015 278 7084
h.a.duong@tudelft.nl
www.cheme.tudelft.nl

Simulations of a droplet arriving at a microfluidic T-junction: (1) symmetric breakup; (b) asymmetric breakup; (c) drifting

PROJECT AIM

Segmented flow is widely used in microreactor (Process-on-a-Chip and Lab-on-a-Chip) technology because of its high mass transfer, low axial dispersion and rapid micromixing. The generation and control of segmented flow in a single microchannel is well-established. Numbering up towards large-scale processing, however, required techniques for the stable and controlled distribution of segmented flows over networks of channels. As yet, techniques and fundamental understanding of such distributions are limited. In this project, we study the generation and transport of droplets and bubbles in microfluidic networks that comprise a large number of parallel microchannels. The aim is to understand how to form and distribute streams of bubbles or droplets in such networks.

PROGRESS

- Studied the dynamics of droplet breakup in microfluidic T-junctions using 3-D numerical simulations.
- Formulated general design and scale-up rules for a breakup-based Taylor flow distributor for multiple microreactors.

DISSERTATIONS

1. D.A. Hoang, "Breakup of confined droplets in microfluidics", TU Delft, October 16, 2013.

SCIENTIFIC PUBLICATIONS

1. D. A. Hoang, L. M. Portela, C. R. Kleijn, M. T. Kreutzer and V. van Steijn, "Dynamics of droplet breakup in a T-junction", *J. Fluid Mechanics* 717, R4 (2013), paper #R4.
2. Duong A Hoang, Volkert van Steijn, Luis M. Portela, Michiel T. Kreutzer, Chris R. Kleijn, "Benchmark numerical simulations of segmented multiphase flows in microchannels using the Volume of Fluid method", *Computer & Fluids*, 86, (2013) pp. 28–36.
3. Hoang, AD, Steijn, V van, Portela, L, Kreutzer, MT & Kleijn, CR, "Confined droplets at T-junctions", *Proceedings 2013 AIChE Annual Meeting*, San Francisco, CA (pp. 1-1).

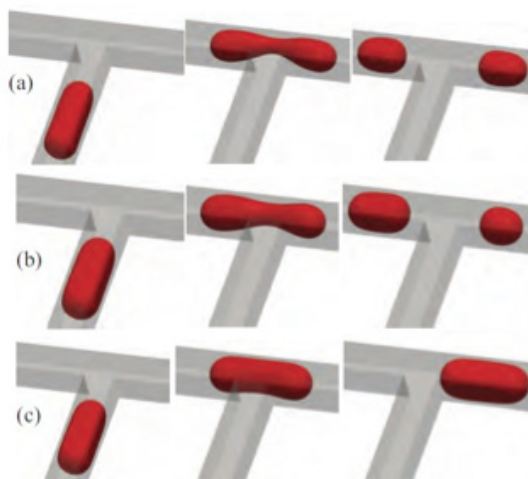

MULTIPHASE FLOW IN INTERNALLY STRUCTURED MICROCHANNELS UNDER PARTIAL WETTING CONDITIONS

PROJECT AIM

In this project we aim to develop a CFD model to predict multiphase flow in micro- and millifluidic channels under partial wetting conditions. The partial wetting condition introduces additional fluids-solid interactions, which have a significant influence on the flow behaviour due to the dominance of capillary forces. A quantitative understanding of the fluids-solid interactions is of importance to accurately model the surface tension dominated multiphase flow. Therefore, the focus is on understanding and controlling the dynamics of the fluids-solid interface.

PROGRESS

To understand the complex interaction between a partially wetting liquid and a solid we have translated the two-phase micro/millifluidic system into a model system of a liquid droplet on an inclined solid substrate (see figure below). We use numerical and analytical energy minimization to study the deformation and onset of motion of the droplet. Important in the energy minimization is to correctly account for constraints on the motion of the contact line of the droplet. By taking the local nature of the constraints into account we can theoretically predict the evolution of the contact line of the droplet in good agreement with the numerical results which we experimentally validate. We find that families of droplets exist with equal volume and base width that all obtain the same shape at the onset of motion ($\alpha = \alpha_c$).

DISSERTATIONS

-

SCIENTIFIC PUBLICATIONS

1. Prediction of Droplet Deformation and Roll-off From an Inclined Plate, M. Musterd, V. van Steijn, C. R. Kleijn, and M.T. Kreutzer. In 1st Int. Workshop on Wetting and Evaporation: droplets of pure and complex fluids, 17-20 June 2013, Marseilles, 2013.
2. On the Fabrication of PDMS Micromodels by Rapid Prototyping, and Their Use in Two-Phase Flow Studies, N. K. Karadimitriou, M. Musterd, P. J. Kleingeld, M. T. Kreutzer, S. M. Hassanizadeh, and V. Joekar-Niasar, Water Resources Research, 49 (4), p. 2056-2067, 2013.

PROJECTLEADERS

CR Kleijn, MT Kreutzer

RESEARCHTHEME

Complex dynamics of fluids

PARTICIPANTS

M Musterd

COOPERATIONS

JM van Beek (UT), L Lefferts (UT), Shell, DOW, ECN, Sulzer

FUNDED

| | |
|--------------|-------|
| ISPT | |
| University | - |
| FOM | - |
| STW | - |
| NWO Other | - |
| Industry | 100 % |
| TNO | - |
| GTI | - |
| EU | - |
| Scholarships | - |

START OF THE PROJECT

2010

INFORMATION

M Musterd
015 278 7084
m.musterd@tudelft.nl
<http://cheme.nl/tp/musterd>

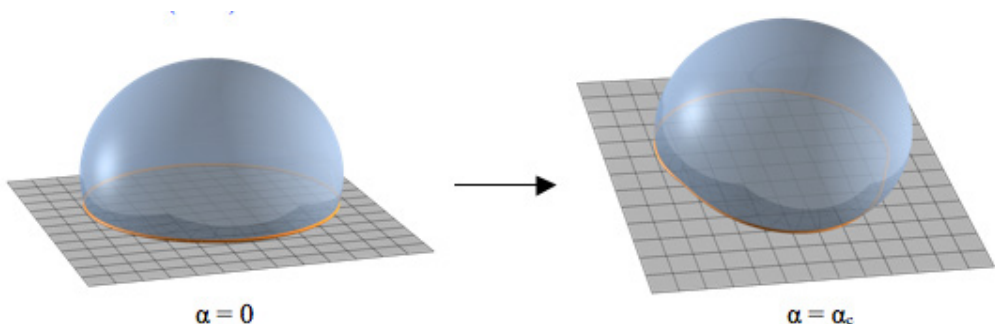

MODEL EXPERIMENTS ON IMPROVED CONTINUOUS STEEL CASTING THROUGH ELECTROMAGNETIC FLOW CONTROL

PROJECT LEADERS

CR Kleijn, S Kenjereš, M Tummers

RESEARCH THEME

Complex dynamics of fluids

PARTICIPANTS

R Kalter

COOPERATIONS

Tata steel, ABB

FUNDED

Tata steel, ABB, STW

University -

FOM -

STW 88 %

NWO Other -

Industry 12 %

TNO -

GTI -

EU -

Scholarships -

START OF THE PROJECT

2010

INFORMATION

R Kalter

r.kalter@tudelft.nl

015 212 82418

<http://cheme.nl/tp/people/kalter.shtml>

PROJECT AIM

The aim of the project is to provide a fundamental understanding of, and experimentally validated models for, the influence of electromagnetic fields on flow, turbulence and heat transfer in liquid steel during continuous casting. These insights and models will make it possible to design and to optimize new strategies for controlling steel casting processes, leading to significant energy savings, increased productivity and improved product quality.

PROGRESS

PIV measurements have been performed in measurements with a single jet flowing into a thin cavity with and without electromagnetic forcing. Electromagnetic forcing can be in an up-down-up configuration, or in the down-up-down configuration. Without electromagnetic forcing self-sustained jet oscillations occur in this experiment. The frequency of the oscillation grows linearly with the inlet velocity. It was found that the Lorentz force in the up-down-up configuration can be used to enhance self-sustained jet oscillations starting at a critical Stuart number of $N = 0.01$. With N smaller than 0.01, inertial effects are dominant and the self-sustained jet oscillations have the same frequency as the oscillations without electromagnetic forcing. In the down-up-down forcing configuration, the jet oscillations are suppressed when Reynolds < 5000 ($N > 0.015$). When $Re > 5000$ the inertial effects play a dominant role.

DISSERTATIONS

-

SCIENTIFIC PUBLICATIONS

1. Kalter, R., Tummers, M.J., Kenjeres, S., Righolt, B.W. and Kleijn, C.R.

Oscillations of the fluid flow and the free surface in a cavity with a submerged bifurcated nozzle. International Journal of Heat and Fluid Flow.

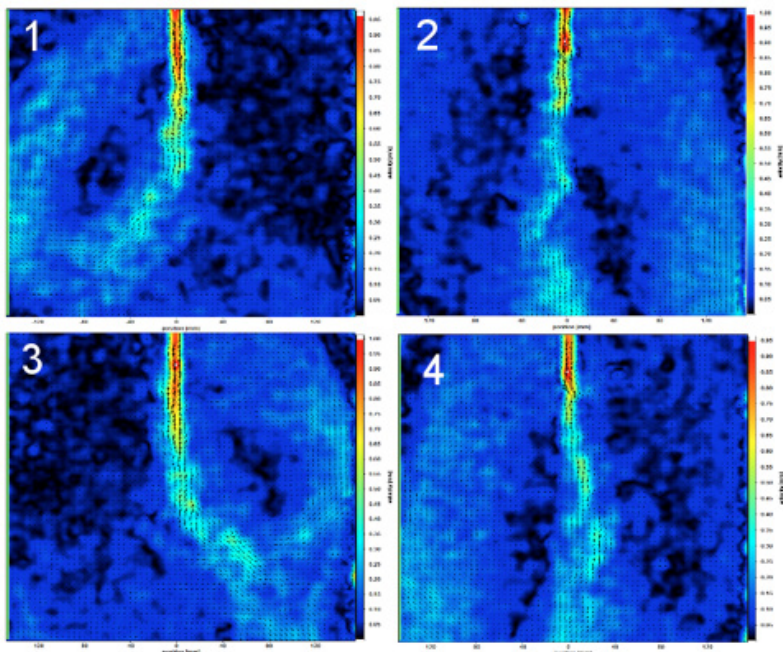

Four PIV snap shots of the different stages of one period of the oscillation of a jet flowing into a thin cavity.

HYBRID RANS/LES SIMULATIONS OF TURBULENT FLOWS OVER HILLS AND COMPLEX URBAN AREAS WITH DISPERSION OF POLLUTANTS

PROJECT AIM

This project is part of the long-term investigations started at former Department of Multi Scale Physics aimed at the mathematical modeling and numerical simulations of environmental flows and turbulent dispersion of passive and reactive scalars. In this particular project we focus our investigation at the turbulent flows over complex terrains and urban areas (street canyons) partially covered with vegetation and with different sources of the passive or reactive scalars (the point-, the line- and the area-concentration sources).

PROGRESS

We developed a new class of the seamless hybrid RANS/LES approach suitable for the complex urban areas partially covered with vegetation. We successfully reproduced detailed laboratory-scale measurements for different geometrical configurations reported in literature. Also, the mechanism of the ozone-depletion in urban areas is validated.

DISSERTATIONS

-

SCIENTIFIC PUBLICATIONS

1. Kenjeres S. and ter Kuile B. (2013), "Modelling and simulations of turbulent flows in urban areas with vegetation", Journal of Wind Engineering and Industrial Aerodynamics, Vol. 123, pp.43-55. (doi: 10.1016/j.jweia.2013.09.007).

PROJECT LEADERS

S Kenjeres

RESEARCH THEME

Complex dynamics of fluids

PARTICIPANTS

S Kenjeres

COOPERATIONS

Prof. H. J. J. Jonker, CiTG TU Delft

Dr. S.R. De Roode, CiTG, TU Delft

FUNDED

| | |
|--------------|-------|
| University | 100 % |
| FOM | - |
| STW | - |
| NWO Other | - |
| Industry | - |
| TNO | - |
| GTI | - |
| EU | - |
| Scholarships | - |

START OF THE PROJECT

2006

INFORMATION

S Kenjeres

015 278 3649

S.Kenjeres@tudelft.nl

www.msp.tudelft.nl

isosurfaces of the vertical velocity (red-negative, blue-positive) within a complex urban area with heating from the bottom plane and with emission of reactive scalars (the ozone depletion). An instantaneous snapshot from the new seamless hybrid RANS/LES method, Kenjeres et al. (2013).

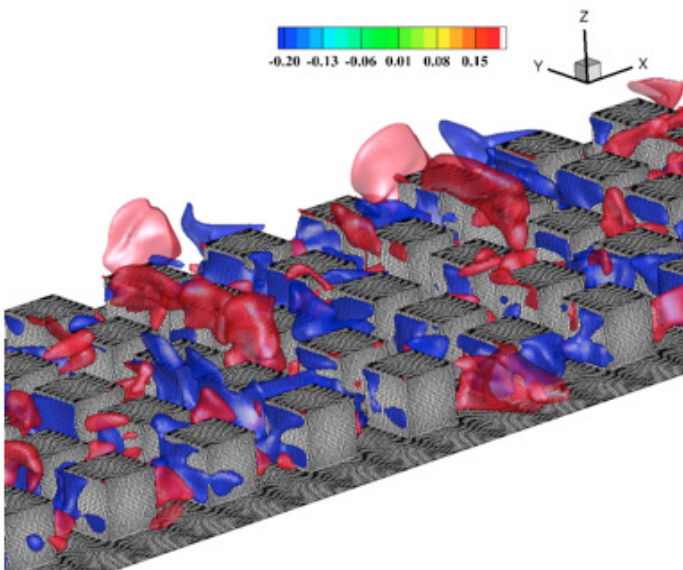

PROJECT LEADERS

S Kenjeres

RESEARCH THEME

Complex dynamics of fluids

PARTICIPANTS

S Kenjeres, JS Szmyd, E Fornalik-Wajs

COOPERATIONS

AGH University of Science and Technology, Krakow, Poland

FUNDED

AGH University of Science and Technology, Krakow, Poland, EC Marie Curie University 50 %

FOM -

STW -

NWO Other -

Industry -

TNO -

GTI -

EU 50 %

Scholarships -

START OF THE PROJECT

2007

INFORMATION

S Kenjeres

015 278 3649

S.Kenjeres@tudelft.nl

www.msp.tudelft.nl

Top-the spatial distributions of the magnetic flux lines (gray tubes) and selected iso-surfaces of the magnetic field intensity ($|b_0| = 1.5, 5$ and 10 T. Bottom- contours of the vertical gradient of the magnetic induction for the upper limit of working parameters ($|b_0|_{max} = 10$ T) for experimental setup with a super-conducting magnet setup (up to 10T), Kenjeres et al. (2013).

PROJECT AIM

This is a joint project between Transport Phenomena Section, Department of Chemical Engineering at the TU Delft and the Department of Fundamental Research in Energy Engineering, Faculty of Energy and Fuels, AGH University of Science and Technology, Krakow, Poland. The project is aimed at fundamental investigations of flow stability and wall heat transfer of paramagnetic fluids in presence of strong magnetic field gradients.

PROGRESS

Experimental measurements of the integral heat transfer performed over a range of working parameters for a differentially heated cubical enclosure of a paramagnetic fluid subjected to magnetic gradients of different orientation and strength. DNS studies of the flow and heat transfer performed and detailed comparison with experiments performed.

DISSERTATIONS

-

SCIENTIFIC PUBLICATIONS

1. Kenjeres S., Pyrda L., Fornalik-Wajs E. and Szmyd J. S. (2013), "Numerical and Experimental Study of Rayleigh-Benard-Kelvin Convection", Flow, Turbulence and Combustion, in press.
(online first November 2013) (DOI: 10.1007/s10494-013-9490-8)

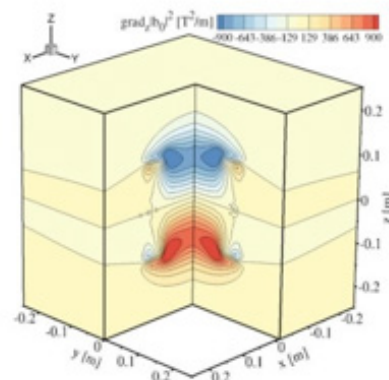
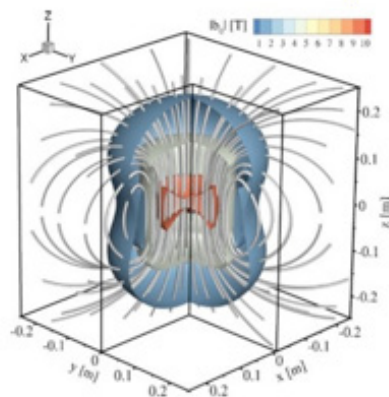

NUMERICAL SIMULATIONS AND EXPERIMENTS OF FLOW, TURBULENCE AND MASS TRANSFER CONTROL OF ELECTRICALLY CONDUCTING FLUIDS BY IMPOSED ELECTROMAGNETIC FIELDS

PROJECT AIM

Numerical cal simulations and modeling of thermal and magnetic convection at very high Rayleigh and Hartmann numbers has long been a serious challenge because of the profound effects that buoyancy and Lorentz forces have on the reorganization of the vortical structures, and because of the extreme thinning of the wall boundary layers which requires high numerical resolution. The aim of this study is to develop physically well-based and numerically efficient approaches to tackle problems of highly turbulent thermal and magnetic convection in complex geometries.

PROGRESS

We performed DNS studies of flow around magnetic obstacles in transitional and turbulent flow regimes.

DISSERTATIONS

-

SCIENTIFIC PUBLICATIONS

1. Kenjeres S. (2013), "On turbulence generation and mixing in the wake of magnetic obstacles: a DNS study", Ercoftac Workshop Direct and Large-Eddy Simulation DLES-9, TU Dresden, Institute of Fluid Mechanics, Dresden, Germany, 3-5 April, 2013, pp.1-4.
2. Kenjeres S. (2013), Invited lecture, "On modelling and simulations of (E)MHD turbulent transport phenomena: recent progress and challenges", 549. WE-Heraeus-Seminar, Liquid Metal MHD, 15-18 October 2013, Physikzentrum Bad Hannef, Germany.

PROJECT LEADERS

S Kenjeres, CR Kleijn

RESEARCH THEME

Complex dynamics of fluids

PARTICIPANTS

S Kenjeres

COOPERATIONS

-

FUNDED

| | |
|--------------|-------|
| TU Delft | |
| University | 100 % |
| FOM | - |
| STW | - |
| NWO Other | - |
| Industry | - |
| TNO | - |
| GTI | - |
| EU | - |
| Scholarships | - |

START OF THE PROJECT

2006

INFORMATION

S Kenjeres
 015 278 3649
 S.Kenjeres@tudelft.nl
 www.msp.tudelft.nl

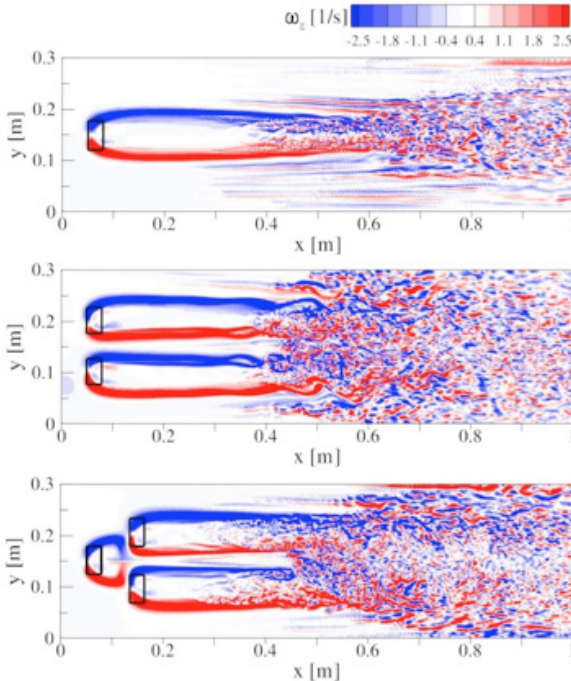

Instantaneous vertical vorticity in flow around magnetic obstacle(s) with laminar approaching conditions, Re=1000 and high electric conductivity, Kenjeres (2013)

NUMERICAL MODELING AND SIMULATIONS OF BLOOD FLOW AND MAGNETIC PARTICLES IN SIMPLIFIED AND REALISTIC ARTERIAL GEOMETRIES : TOWARDS OPTIMIZED MAGNETIC DRUG DELIVERY

PROJECT LEADERS

S Kenjeres

RESEARCH THEME

Complex dynamics of fluids

PARTICIPANTS

S Kenjeres

COOPERATIONS

ERASMUS Medical Center
Rotterdam, Leiden University
Medical Center (LUMC)

FUNDED

TU Delft
University 100 %
FOM -
STW -
NWO Other -
Industry -
TNO -
GTI -
EU -
Scholarships -

START OF THE PROJECT

2006

INFORMATION

S Kenjeres
015 278 3649
S.Kenjeres@tudelft.nl
www.msp.tudelft.nl

Numerical simulations of pulsating blood flow and magnetic drug targeting in the detailed brain vascular system: The pressure (-left) and magnetic field (-right) distributions in a real patient brain vascular geometry, Kenjeres and Righolt (2012).

PROJECT AIM

One of the main problems of chemotherapy is often not the lack of efficient drugs, but the inability to precisely deliver and concentrate these drugs in affected areas. Failure to provide localized targeting results in an increase of toxic effects on neighboring organs and tissues. One promising method to accomplish precise targeting is magnetic drug delivery. Here, a drug is bound to a magnetic compound injected into the blood stream. The targeted areas are subjected to an external magnetic field that is able to affect the blood stream by reducing its flow rate. We believe that mathematical modeling and numerical simulations can significantly contribute to further advancements of this technique.

PROGRESS

We have developed a comprehensive mathematical model for simulations of blood-flow under the presence of strong non-uniform magnetic fields. The model consists of a set of Navier-Stokes equations accounting for the Lorentz and magnetization forces, and a simplified set of Maxwell's equations (Biot-Savart/Ampere's law) for treating the imposed magnetic fields. The model is then validated for different patient-specific geometries (including a carotid artery and brain vascular system).

DISSERTATIONS

-

SCIENTIFIC PUBLICATIONS

1. Rusli M., Kueh A. B. H. and Kenjeres S. (2013), "Magnetic field effects on 3D blood flow patterns of straight and stenotic arteries", *Advanced Science Letters* 19 (9), pp.2690-2693.
2. Kenjeres S. (2013), "Invited lecture: Computer Simulations Based Optimization of Magnetic Drug Targeting and Delivery in Patient Specific Vascular Geometries", 5th International Conference on Drug Discovery and Therapy, Dubai, U.A.E., February 18-21, 2013, extended abstract, pp.1-2.
3. Kenjeres S. (2013), "Simulations of Magnetic Drug Capturing in the Patient Specific Vascular Systems", 9th European Congress on Chemical Engineering, World Forum, The Hague, The Netherlands, April 21-25, 2013, extended abstract.

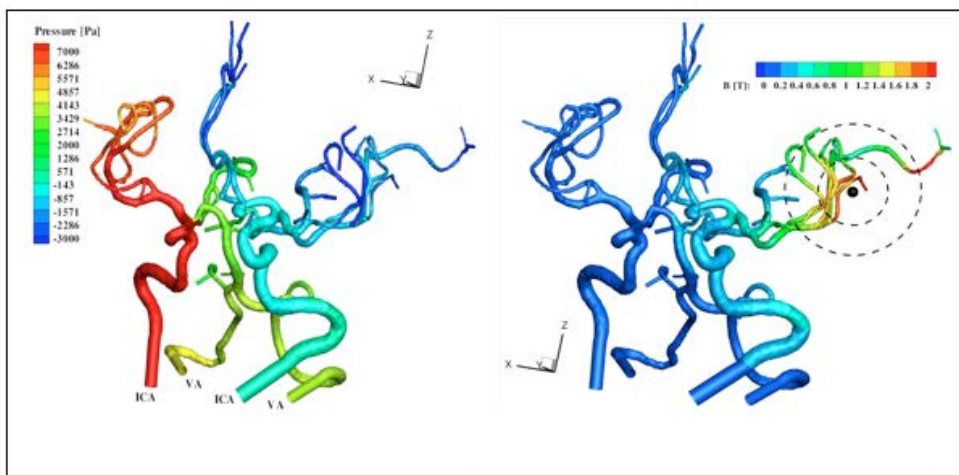

EXPERIMENTAL AND NUMERICAL INVESTIGATIONS OF TRANSITIONAL AND TURBULENT FLOWS OVER COMPLEX SURFACE WITH HEAT TRANSFER AND EMISSION OF PASSIVE SCALARS

PROJECT AIM

This is a joint project between Transport Phenomena Section, Department of Chemical Engineering at the TU Delft and the Laboratory for Transport Processes and Reactions of Prof. P. Rudolf von Rohr at ETH Zurich. The project addresses the combined experimental and numerical study of turbulent flows over complex surfaces with heat transfer and distribution of passive scalars. The final goal is to perform in parallel state-of-the-art experiments (stereo PIV, LIF, TLC) and numerical simulations (LES, hybrid RANS/LES, DES, RANS) for different wall configurations over a range of Reynolds numbers and intensities of the wall heat flux and scalar emissions.

PROGRESS

Experimental (PIV, LIF) and numerical studies (DNS, LES with dynamic Lagrangian SGS closure) performed for different configurations of narrow channels with a porous medium.

DISSERTATIONS

-

SCIENTIFIC PUBLICATIONS

-

PROJECT LEADERS

S Kenjeres, CR Kleijn

RESEARCH THEME

Complex dynamics of fluids

PARTICIPANTS

S Kenjeres, P Rudolf von Rohr,
A Zenklusen

COOPERATIONS

ETH Zürich, P. von Rohr

FUNDED

TU Delft, ETH Zurich, HPC-Europa 2

University 50 %

FOM -

STW -

NWO Other -

Industry -

TNO -

GTI -

EU 50 %

Scholarships -

START OF THE PROJECT

2006

INFORMATION

S Kenjeres

015 278 3649

S.Kenjeres@tudelft.nl

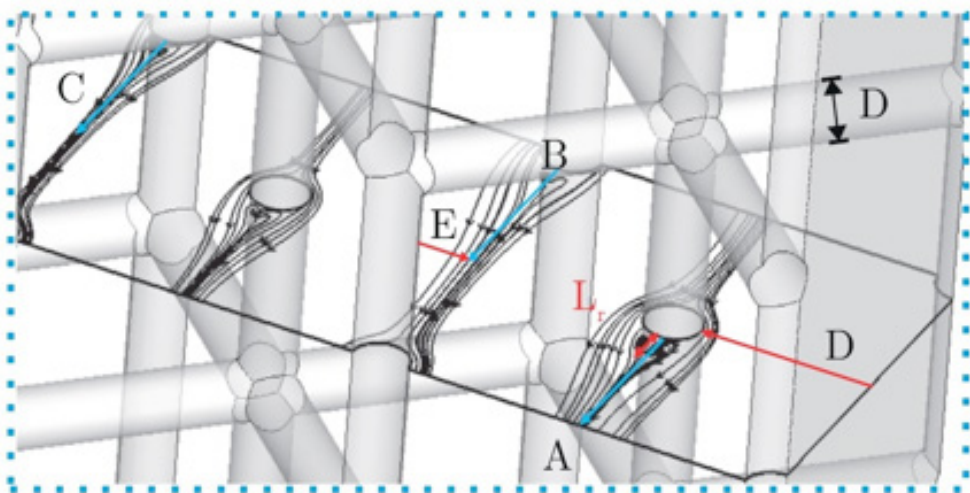

the wake structures and vortex shedding in dynamic LES simulation of the flow within a complex porous segment of a micro-reactor for which a detailed PIV and LIF measurements are performed at ETH.

PERFORMANCE OF FOAMERS FOR DELIQUIFICATION OF GAS WELLS

PROJECT LEADERS

RAWM Henkes, L Portela

RESEARCH THEME

Complex structures of fluids

PARTICIPANTS

AT van Nimwegen

COOPERATIONS

NAM/Shell

FUNDED

NAM

University 25 %

FOM -

STW -

NWO Other -

Industry 75 %

TNO -

GTI -

EU -

Scholarships -

START OF THE PROJECT

2010

INFORMATION

RAWM Henkes

015 278 1323

R.A.W.M.Henkes@tudelft.nl

www.msp.tudelft.nl

PROJECT AIM

This project is a combined experimental/modeling study on the performance of foamers for deliquification of gas wells as used in the gas and oil industry. The reduction of the reservoir pressure for maturing fields will cause that gas wells will start to accumulate liquid (water, condensate). The use of proper foamer chemicals will mix the liquid and gas into a foam, which decreases the hydrostatic head in the well and re-establishes the flow. The study includes flow experiments using a 12 m, 5 cm diameter facility.

PROGRESS

The experiments in the flow facility were continued. The influence of surfactants on the flow pattern map for vertical air-water flow was determined at two different surfactant concentrations. Three different surfactants were used in the experiments, showing a great qualitative similarity in the results. Furthermore, it was found that the critical micelle concentration of the surfactants cannot be used to predict the required dose rate of the surfactants. The existing flow facility was expanded with two additional tubes. The first has a diameter of 34 mm, and is also 12 m in length. It is mounted on the same frame as the original setup, and can therefore be inclined. The second has an 80 mm diameter, and a length of 18 meters. It is mounted on a separate frame, and cannot be inclined. Both new setups have automated gas and liquid flow control. Initial results in the 34 mm pipe show similar results as for the 50 mm pipe.

DISSERTATIONS

-

SCIENTIFIC PUBLICATIONS

1. Nimwegen, AT van, Portela, L & Henkes, RAWM (2013). The effect of surfactants on upward air-water flow at different pipe inclinations. In Moo Hwan Kim (Ed.), USB stick (pp. 1-12). Jeju, Zuid Korea: s.n..
2. Nimwegen, AT van, Portela, L & Henkes, RAWM (2013). The Effect of Surfactants on Vertical Air/Water Flow for Prevention of Liquid Loading. In s.n. (Ed.), Cd International Symposium on Oilfield Chemistry (pp. 1-15). The Woodlands, TX, USA: Society of Petroleum Engineers.



$D = 34 \text{ mm}$



$D = 50 \text{ mm}$



$D = 80 \text{ mm}$

SIMULATION OF AGGLOMERATION AND COATING NANOPARTICLES IN A FLUIDIZED BED

PROJECT AIM

The aim of this project is to investigate the complex agglomeration dynamics and mass transfer phenomena for the atomic layer deposition (ALD) on nanoparticles in the fluidized bed reactor. A schematic picture of the process is shown in Figure 1 below. The challenge is to understand how nanoparticles agglomerate to loose dynamic clusters and understand the agglomeration process in gas flows during coating, such that uniform coatings can be made. Since the relevant length scales range from nm to cm, a multi-scale modeling approach will be required.

PROGRESS

Preliminary simulations for the drag on a single sphere in rarefied gas flow were conducted using OpenFOAM continuum CFD and DSMC methods. A literature review on the hydrodynamic force on clusters/agglomerates of nanoparticles at different flow regimes was produced. A literature review on the different numerical methods used in the fluidized bed simulation and agglomeration dynamics were conducted which lead to the conclusion that DSMC with bottom-up approach will be applied to our problem.

DISSERTATIONS

-

SCIENTIFIC PUBLICATIONS

-

Schematics of ALD on nanoparticles in a fluidized bed.

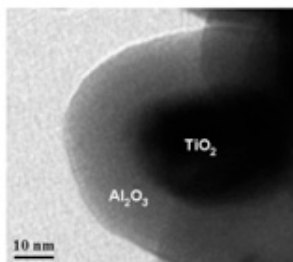

Hakim et al, *J. Am. Ceram. Soc.*, 89 3070-3075 (2006)

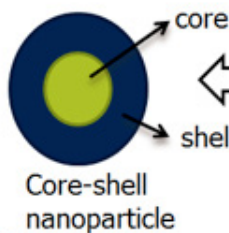

PROJECT LEADERS

JR van Ommen, CR Kleijn

RESEARCH THEME

Mathematical and computational methods for fluid flow analysis

PARTICIPANTS

Wenjie Jin

COOPERATIONS

ASM, NanoNextNL

FUNDED

European Research Council (ERC)

University -

FOM -

STW -

NWO Other -

Industry -

TNO -

GTI -

EU 100 %

Scholarships -

START OF THE PROJECT

2012

INFORMATION

JR van Ommen

015 278 2133

J.R.vanOmmen@tudelft.nl

<http://cheme.nl/ppe/people/vanommen.shtml>

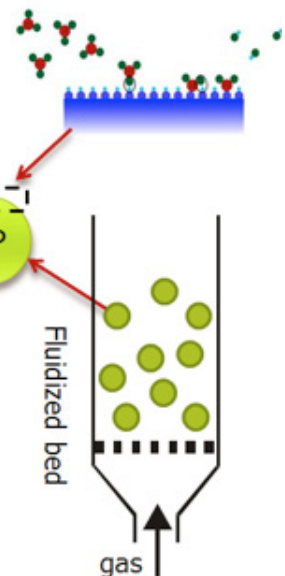

MODELLING THE INFLUENCE OF FLOW ON ASPHALTENE AGGLOMERATION AND DEPOSITION

PROJECT LEADERS

RAWM Henkes, LM Portela,
A Twerda

RESEARCH THEME

Mathematical and computational
methods for fluid flow analysis

PARTICIPANTS

K Schutte

COOPERATIONS

TNO, ENI (ISAPP2)

FUNDED

| | |
|--------------|------|
| ENI | |
| University | 25 % |
| FOM | - |
| STW | - |
| NWO Other | - |
| Industry | 75 % |
| TNO | - |
| GTI | - |
| EU | - |
| Scholarships | - |

START OF THE PROJECT

2011

INFORMATION

RAWM Henkes
015 278 1323
R.A.W.M.Henkes@tudelft.nl
www.msp.tudelft.nl

PROJECT AIM

Asphaltenes are heavy organic deposits that can be formed when the oil transport from subsurface reservoirs undergoes a sharp drop in pressure. This can be at the inflow sections from the reservoir into the well bore, or inside the wellbore, pipeline, or downstream facilities. For example injection of chemicals can help to prevent blockage of the production system. Models are used for the design of asphaltene prediction, which in turn are used for the design of deposition prevention and remediation methods. Models used so far in the oil and gas industry are highly empirical. The aim of the present project is to better understand the fundamentals of the influence of flow on the agglomeration and deposition process of asphaltenes. This will result into both new detailed flow models, as well as into improved models that can be used in the industry.

PROGRESS

The primary particle based agglomeration and break-up model implemented last year was extended such that break-up of agglomerates can be considered as a function of the four principal modes of induced stress in the inter-particle bonds: straining, shearing, bending and torsion. Simulations were conducted for all modes of break-up, at multiple Reynolds numbers, both considering one- and two-way coupling. In all cases considered, scaling relations for the mean agglomerate mass with the strength of the inter-particle bonds and the Reynolds number were obtained, yet with different scaling exponents for different break-up modes. The structure of agglomerates (form factor, fractal dimension, ...) on the other hand, to large extent is invariant to the strength of the inter-particle bonds, the break-up mode and the Reynolds number. Currently, the model is being extended with a deposition module, in which also re-entrainment of particles into the flow will be taken into account.

DISSERTATIONS

SCIENTIFIC PUBLICATIONS

1. K.C.J. Schutte, L.M. Portela and R.A.W.M. Henkes. A Numerical Study on the Formation and Break-up of Particle Agglomerates. 8th International Conference on Multiphase Flows, paper 731, 2013.

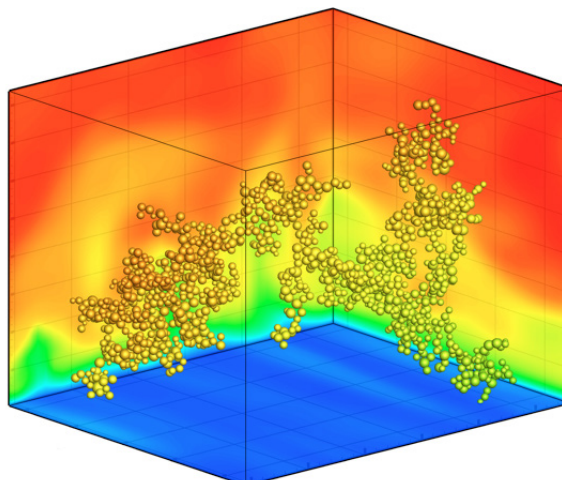

Snapshot of agglomerate formed in turbulent flow (shown in background).

LIQUID-LIQUID SEPARATION USING A SWIRLING FLOW

PROJECT AIM

To develop an inline separator that is capable to separate oil from water at a wide range of volume fractions in an industrial oil/water line.

PROGRESS

We have performed an extensive experimental campaign in which we studied the performance of three different inline swirl elements in a 10cm diameter pipeline. By measuring the separation efficiency for various flow rates, various water to oil fractions we could understand the flow and separation behavior in our test rig. We varied the swirl strength and we changed the shear rate by using different swirl elements. It is found that shear inside the swirl element, generating small oil and/or water droplets, is in strong competition with the induced swirl that via large g-forces is responsible for the separation. Moreover, the turbulence in the pipe has a negative impact on the separation. It has been concluded that a larger swirl is not necessarily better for the separation. Especially droplet break-up plays a key role.

DISSERTATIONS

-

SCIENTIFIC PUBLICATIONS

-

PROJECTLEADERS

RF Mudde

RESEARCHTHEME

Complex dynamics of fluids

PARTICIPANTS

L van Campen, HWM Hoeijmakers (UT), Various companies

COOPERATIONS

UT, ISPT

FUNDED

| | |
|--------------|-------|
| ISPT | |
| University | - |
| FOM | - |
| STW | - |
| NWO Other | - |
| Industry | 100 % |
| TNO | - |
| GTI | - |
| EU | - |
| Scholarships | - |

START OF THE PROJECT

2009

INFORMATION

RF Mudde

015 278 2834

r.f.mudde@tudelft.nl

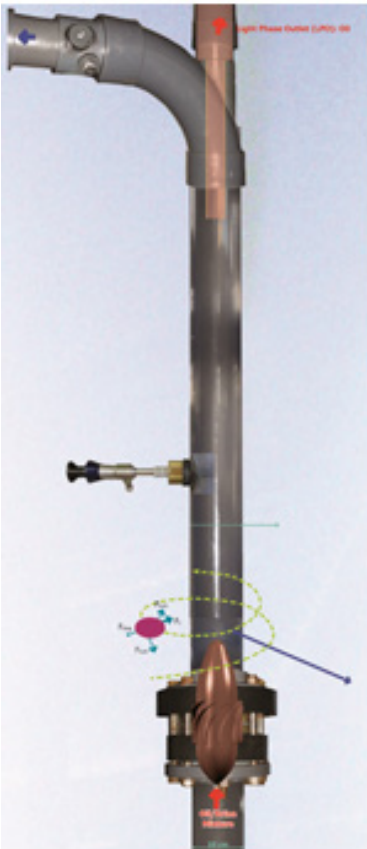

PROJECT LEADERS

RF Mudde

RESEARCH THEME

Complex dynamics of fluids

PARTICIPANTS

F Mousazadeh

COOPERATIONS

-

FUNDED

Shell

University -

FOM -

STW -

NWO Other -

Industry 100 %

TNO -

GTI -

EU -

Scholarships -

START OF THE PROJECT

2009

INFORMATION

RF Mudde

015 278 2834

r.f.mudde@tudelft.nl

PROJECT AIM

Develop a CFD model that can describe and predict the formation of hot spots in a trickle bed reactor.

PROGRESS

We have finalized our work in this project by introducing evaporation and condensation into the (2D) simulations. Evaporation can have a major effect on the formation of hot spots due to the large heat of evaporation involved. This might mitigate or even prevent the formation of hot spots. We have shown that indeed the formation of hot spots is altered by evaporation, but not fully prevented. Hot spots are formed when the liquid flow in the trickle bed in the downstream direction is blocked, e.g. by mal distribution. As the reactants can still diffuse in, but conduction of the heat generated by the chemical reactions is slow, the temperature will rise significantly. This is enhanced if the reaction rate constants increase with increasing temperature (e.g. Arrhenius type) and evaporation does not take away sufficient heat from the reaction zone.

DISSERTATIONS

1. F. Mousazadeh, "Hot spot formation in trickle bed reactors", TU Delft, October 22nd 2013.

SCIENTIFIC PUBLICATIONS

1. Mousazadeh, F, Van den Akker, H.E.A. and Mudde R.F., Direct numerical simulation of an exothermic gas-phase reaction in a packed bed with random particle distribution, Chem. Engng. Science, 100, 259-265, 2013.

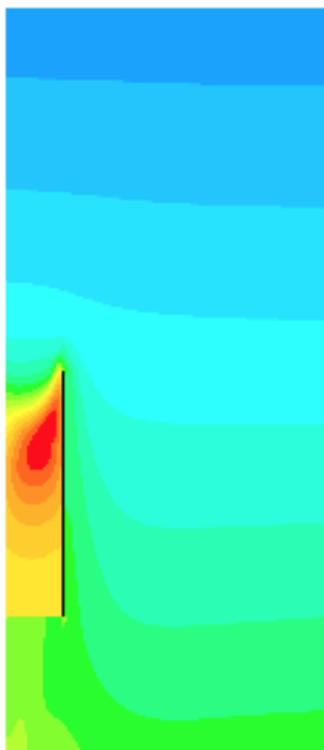

PROJECT AIM

To develop a strategy that allows structuring (in time or space) of slurry bubble columns.

PROGRESS

We have investigated the rise velocity of a single bubble in a neutrally buoyant suspension of particles in a liquid. The particles used ranged in size from 78 micron to four mm. The smallest particles have a Stokes number well below 1, while the largest ones have Stokes numbers well above 1. We show that the case with Stokes number smaller than one can be treated as a pseudo single phase liquid. The particles merely enhance the viscosity and the standard correlations for estimating the bubble rise velocity apply. In case the particle Stokes number is higher than one, the particles literally collide with the rising bubble. Here a mean free path analysis in combination with an estimate of the energy transfer from the bubble to the colliding particle provides a description of the motion of the bubble. From this the average bubble rise velocity is obtained.

DISSERTATIONS

1. N. Hooshyar, "Hydrodynamics of structured slurry bubble columns reactors", TU Delft, January 14th 2013.

SCIENTIFIC PUBLICATIONS

1. Hooshyar, N., Van Ommen, J.R., Hamersma, P.J., Sundaresan, S. and Mudde, R.F., Dynamics of single rising bubbles in neutrally buoyant liquid-solid suspensions, Phys. Rev. Letters, 110 (24), no. 244501, 2013.

PROJECT LEADERS

RF Mudde

RESEARCH THEME

Complex dynamics of fluids

PARTICIPANTS

N Hooshyar, R van Ommen,
P Hamersma

COOPERATIONS

-

FUNDED

| | |
|--------------|-------|
| TU Delft | |
| University | 100 % |
| FOM | - |
| STW | - |
| NWO Other | - |
| Industry | - |
| TNO | - |
| GTI | - |
| EU | - |
| Scholarships | - |

START OF THE PROJECT

2008

INFORMATION

RF Mudde
015 278 2834
r.f.mudde@tudelft.nl

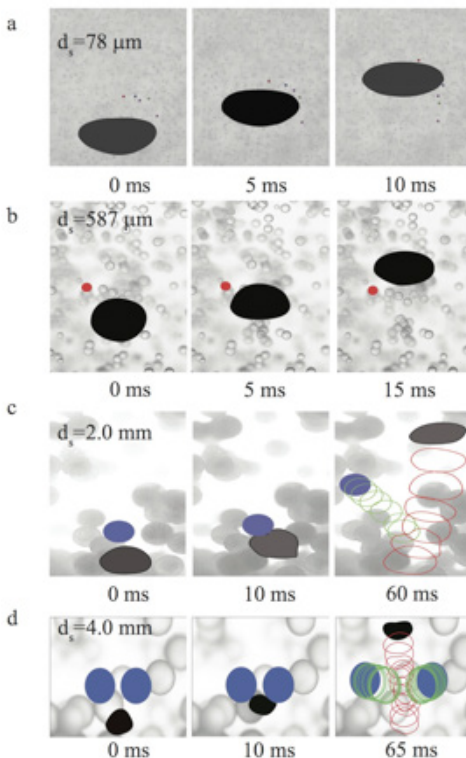

WATER PURIFICATION SYSTEM FOR ONE FAMILY IN THE DEVELOPING WORLD

PROJECT LEADERS

RF Mudde

RESEARCH THEME

Complex dynamics of fluids

PARTICIPANTS

R Bhardwaj

COOPERATIONS

DrTen B.V.

FUNDED

DrTen B.V.

University -

FOM -

STW -

NWO Other -

Industry 100 %

TNO -

GTI -

EU -

Scholarships -

START OF THE PROJECT

2011

INFORMATION

R Bhardwaj

06 34423607

R.bhardwaj@tudelft.nl

PROJECT AIM

To develop an affordable solar distillation system for water purification. The still should be used by the poor in third world countries and hence should rely on solar energy only, have no high tech parts and should be cheap.

PROGRESS

We have investigated the effect of choice of material for condensation surface in a solar still and found that: Reflection is the critical phenomenon effecting water production; Surface tension is the critical property for choosing a material; Thermal resistance offered by condensation layer does not affect the water production; Wiping of condensation surface does not increase the water production. Further, we have performed experiments to understand the effect of additional cooling on production of water inside a solar still. Amongst different ways of cooling, we have demonstrated that the effect of increase in condensation area on the cooling capacity is favorable for increase in production of water in presence of limited resources. A complete model describing the energy flow in the still as well as the mass transfer has been made. This allows for further optimization of the still.

DISSERTATIONS

-

SCIENTIFIC PUBLICATIONS

1. Influence of Condensation Surface on Solar Distillation, R. Bhardwaj, M. V. ten Kortenaar, and R.F. Mudde. Desalination 2013, 326 (0), 37–45.

Droplet condensation pattern on PET and glass surfaces. Scale: 250 μm X 250 μm

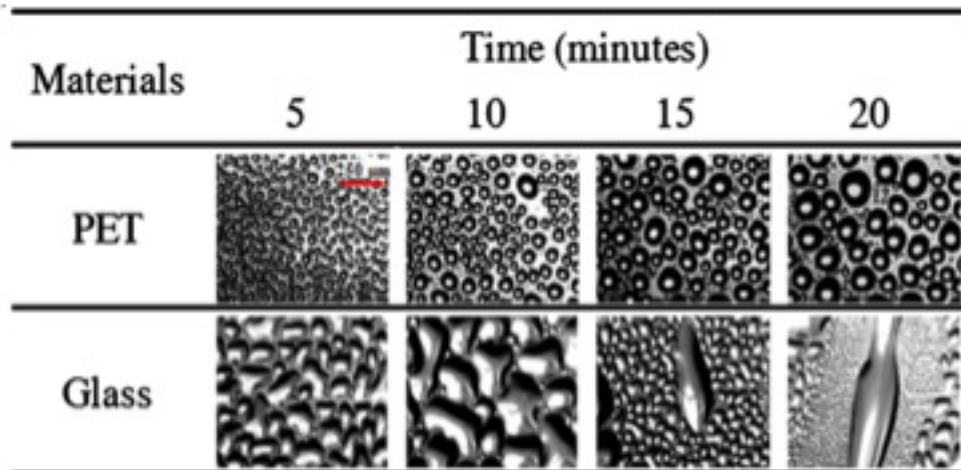

LATTICE BOLTZMANN SIMULATIONS OF MULTIPHASE CHEMICAL REACTORS

PROJECT AIM

The aim of the project is to explore the promises and shift the limits of the numerical framework of Lattice Boltzmann (LB) for studying the physics behind multi-component two-phase heterogeneous non-isothermal reactive flows under industrial conditions.

PROGRESS

A lattice Boltzmann (LB) method has been developed for solving the energy conservation equation in two phases when the phase change effects are included in the model. The approach employs multiple distribution functions, one for a pseudotemperature scalar variable and the rest for the various species. A nonideal equation of state (EOS) is introduced by using a pseudopotential LB model. The evolution equation for the pseudotemperature variable is constructed in such a manner that in the continuum limit one recovers the well known macroscopic energy conservation equation for the mixtures. Heats of reaction, the enthalpy change associated with the phase change, and the diffusive transport of enthalpy are all taken into account; The energy equation is coupled to the LB equations for species transport and pseudopotential interaction forces through the EOS by using the filtered local pseudotemperature field. The proposed scheme is validated against simple test problems for which analytical solutions can readily be obtained.

Dispersed gas (vapor) liquid flow through an inclined bended microchannel has been simulated by means of a two-phase Lattice Boltzmann method. Combining in this method the Shan-Chen pseudopotential interaction model with the Yuan and Schaefer proposal for dealing with nonideal equations of state makes high density ratios achievable. This approach also allows simulation of gas liquid flows without explicitly having to track the phase interfaces. Rather, a potential function related to the equation of state for vapor liquid equilibrium, a coupling strength representing attraction or repulsion between species, and a relaxation time scale take care of microscale and mesoscale phenomena such as phase separation and interfacial tension as well as interphase transport and multiphase flow. In addition, fluid wall interaction (contact angle) is taken into account by selecting proper potential functions and coupling strengths. As far as the phase behavior is concerned, we assessed our method by studying the phase separation process and by validating against Maxwell's equilibrium rule. Qualitative validation of our approach of gas liquid flow has been done with a comparison against experimental data on a single bubble rise. Detailed simulations were carried out for an individual Taylor bubble in a channel, the results of which compared favorably to literature data.

DISSERTATIONS

-

SCIENTIFIC PUBLICATIONS

1. M.R. Kamali and H.E.A. van den Akker, "Simulating Gas-Liquid Flows by Means of a Pseudopotential Lattice Boltzmann Method", *INDUSTRIAL & ENGINEERING CHEMISTRY RESEARCH*, 52(33), 2013, pp11365-11377.
2. Kamali, MR ; Gillissen, JJJ ; Van den Akker, H.E.A.; Sundaresan, S , "Lattice-Boltzmann-based-two-phase thermal model for simulating phase change", *PHYSICAL REVIEW E*, 88(3), 2013, #033302.

PROJECT LEADERS

HEA van den Akker

RESEARCH THEME

Mathematical and computational methods for fluid flow analysis

PARTICIPANTS

M Kamali, JJJ Gillissen

COOPERATIONS

S Sundaresan (Princeton uni.)

FUNDED

| | |
|--|------|
| STW, Shell Global Solutions University | - |
| FOM | - |
| STW | 75 % |
| NWO Other | - |
| Industry | 25 % |
| TNO | - |
| GTI | - |
| EU | - |
| Scholarships | - |

START OF THE PROJECT

2008

INFORMATION

HEA van den Akker

015 278 5000

h.e.a.vandenakker@tudelft.nl

PROJECT LEADERS

RF Mudde

RESEARCH THEME

Complex dynamics of fluids

PARTICIPANTS

X Yang, JR van Ommen

COOPERATIONS

-

FUNDED

University -

FOM -

STW -

NWO Other -

Industry -

TNO -

GTI -

EU -

Scholarships 100 %

START OF THE PROJECT

2011

INFORMATION

RF Mudde

015 278 2834

r.f.mudde@tudelft.nl

PROJECT AIM

Study the hydrodynamics of various applications of fluidized beds using a fast X-ray tomographic system.

PROGRESS

We have been testing the use of Genetic Algorithms to reconstruct limited data sets that we obtained from our X-ray set up. We have shown that a so-called Adaptive Genetic Algorithm out performs the traditional SART reconstruction technique in finding small objects. Hence, using AGA increases the spatial resolution. On the other hand, AGA renders more erratic shapes than SART. Moreover, AGA is slow and requires too long reconstruction times. Our results suggest that a combination of SART and AGA may be better and combine the advantages of both methods. This is currently under investigation. We have used our X-ray facility to investigate the dynamics of a spouted bed: a fluidized system in which a central gas jet is blown creating a central spout. We have measured several spout features and derived a particle circulation model from the data. We estimated the stability of the spout size and position for various flow conditions. We have measured the flow pattern and dynamics of a downward micro-nozzle system for fluidized bed. This system is expected to assist the fluidization of nano-particles. The time-resolved gas distribution is obtained by our X-ray facility. A stable bubbling flow is found with this system from our recent results.

DISSERTATIONS

-

SCIENTIFIC PUBLICATIONS

1. Rautenbach, C., Mudde, R.F., Yang, X., Melaaen, M.C., Halvorsen, B.M., A comparative study between electrical capacitance tomography and time-resolved X-ray tomography, Flow Meas and Instr., 30, 34-44, 2013.

TURBULENT DRAG REDUCTION

PROJECT AIM

To understand the mechanism for drag reduction in turbulent flows due to the addition of spherical additives, such as solid particles or gas bubbles.

PROGRESS

Using direct numerical simulations of turbulent Couette flow, we have predicted drag reduction in suspensions of neutrally buoyant fluid spheres, of diameter larger than the Kolmogorov length scale. The velocity fluctuations are enhanced in the streamwise direction, and reduced in the cross-stream directions, which is similar to the more studied case of drag reduction using polymers. Despite these similarities, the drag reduction mechanism is found to originate in the logarithmic region, while the buffer region contributes to a slight drag increase, which is opposite to polymer-induced drag reduction. Another striking difference is the reduction of the turbulent energy at the large scales and an enhancement at the small scales.

DISSERTATIONS

-

SCIENTIFIC PUBLICATIONS

1. J.J.J. Gillissen, Turbulent drag reduction using fluid spheres, *J. Fluid Mech.* (2013), vol. 716, pp. 83-95.

PROJECT LEADERS

JJJ Gillissen

RESEARCH THEME

Complex structures of fluids

PARTICIPANTS

JJJ Gillissen

COOPERATIONS

S Sundaresan, T Odijk

FUNDED

TU Delft

University 100 %

FOM -

STW -

NWO Other -

Industry -

TNO -

GTI -

EU -

Scholarships -

START OF THE PROJECT

2010

INFORMATION

JJJ Gillissen

015 278 9111

J.J.J.Gillissen@tudelft.nl

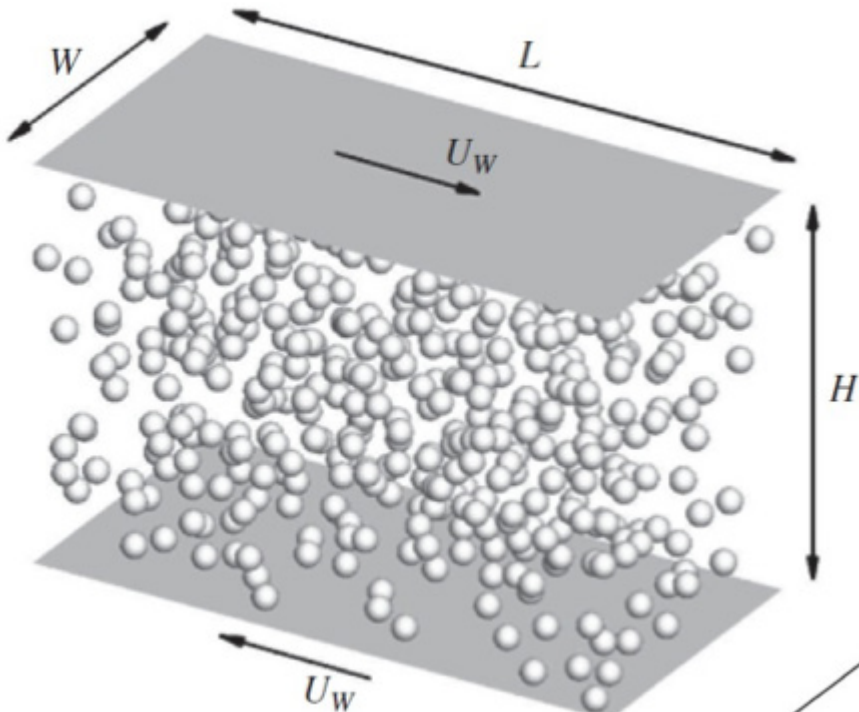

INTERPHASIAL ENERGY TRANSFER AND PARTICLE DISSIPATION IN PARTICLE-LADEN WALL TURBULENCE

PROJECT LEADERS

JJJ Gillissen

RESEARCH THEME

Complex structures of fluids

PARTICIPANTS

JJJ Gillissen

COOPERATIONS

S Sundaresan

FUNDED

TU Delft

University 100 %

FOM -

STW -

NWO Other -

Industry -

TNO -

GTI -

EU -

Scholarships -

START OF THE PROJECT

2010

INFORMATION

JJJ Gillissen

015 278 9111

J.J.J.Gillissen@tudelft.nl

PROJECT AIM

To study the mechanism for the transfer of mechanical energy between solid spherical particles and a turbulent Newtonian wall flow.

PROGRESS

- Transfer of mechanical energy between solid spherical particles and a Newtonian carrier fluid has been explored in two-way coupled direct numerical simulations of turbulent channel flow. The inertial particles have been treated as individual point particles in a Lagrangian framework and their feedback on the fluid phase has been incorporated in the Navier-Stokes equations.

- Inertia effects of large-aspect-ratio fibers have been investigated in wall turbulence. The turbulent flow field in a plane channel was obtained from a direct numerical simulation. The translational and rotational motion of the rigid fibers were obtained by a Lagrangian approach, for inertial fibers with Stokes number $St = 10, 1.0$ and 0.1 and for massless fibers, which correspond to $St = 0$. All simulations were one-way coupled.

DISSERTATIONS

-

SCIENTIFIC PUBLICATIONS

- Lihao Zhao, Helge I. Andersson and Jurriaan J. J. Gillissen, "Interphasial energy transfer and particle dissipation in particle-laden wall turbulence", *J. Fluid Mech.* (2013), vol. 715, pp. 32-59.
- Zhao, L. H.; Andersson, H. I.; Gillissen, J.J.J., "On inertial effects of long fibers in wall turbulence: fiber orientation and fiber stresses", *ACTA MECHANICA*, 224(10), 2013, pp. 2375-2384.

Instantaneous flow contours in a cross-sectional plane: streamwise fluid velocity (colour contours) and point particle distribution (black dots)

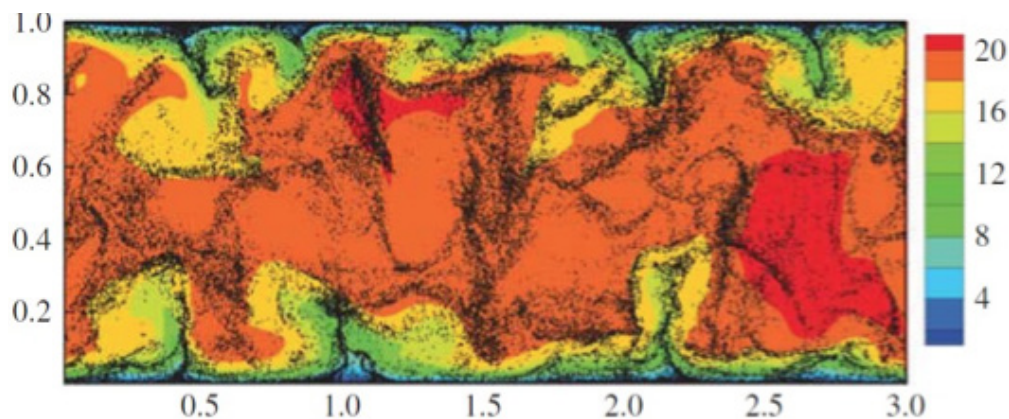

VISCO-ELEASTIC FLOWS

PROJECT AIM

To study the flow of visco-elastic fluids in porous media.

PROGRESS

Polymer solution flow was studied numerically in a periodic, hexagonal array of cylinders as a model for a porous medium. We used a lattice Boltzmann method supplemented by a polymer stress, where the polymers are modeled as finitely extensible, nonlinear, elastic dumbbells. The simulated, nonmonotonic behavior of the effective viscosity $\mu(\text{eff})$ as a function of the Weissenberg number We is in qualitative agreement with experiments in the literature. An analytical model, which replaces the flexible polymers by rods and that replaces the flow field in the porous medium by a superposition of shear and elongation, correctly reproduces the simulated $\mu(\text{eff})$ as a function of the polymer extensibility parameter b in the limit of large We .

DISSERTATIONS

-

SCIENTIFIC PUBLICATIONS

1. J.J.J. Gillissen, "Viscoelastic flow simulations through an array of cylinders", Phys. Rev. E, 87(2), 2013, #023003.

PROJECTLEADERS

JJJ Gillissen

RESEARCHTHEME

Complex structures of fluids

PARTICIPANTS

JJJ Gillissen

COOPERATIONS

S Sundaresan

FUNDED

| | |
|--------------|-------|
| TU Delft | |
| University | 100 % |
| FOM | - |
| STW | - |
| NWO Other | - |
| Industry | - |
| TNO | - |
| GTI | - |
| EU | - |
| Scholarships | - |

START OF THE PROJECT

2010

INFORMATION

JJJ Gillissen

015 278 9111

J.J.J.Gillissen@tudelft.nl

SIMULATING THE MESO-SCALE PROCESSES IN TWO-PHASE CHEMICAL REACTORS

PROJECT LEADERS

HEA van den Akker

RESEARCH THEME

Mathematical and computational methods for fluid flow analysis

PARTICIPANTS

N Looije, JJJ Gillissen

COOPERATIONS

S Sundaresan (Princeton uni.)

FUNDED

Shell Global Solutions

University -

FOM -

STW -

NWO Other -

Industry 100 %

TNO -

GTI -

EU -

Scholarships -

START OF THE PROJECT

2011

INFORMATION

JN Looije

N.Looije-1@tudelft.nl

06 149 75799

PROJECT AIM

The aim of the project is to provide a numerical framework for simulating multi-phase catalytic chemical reactors using the Lattice Boltzmann (LB) method. The mesoscopic nature of the LB method allows for an efficient implementation of many relevant phenomena such as phase separation, mass and heat transfer, and catalytic surface chemistry. A large share of the project will deal with combining these implementations and validating the resulting framework using canonical cases from literature. The final part of the project will be to use the framework to analyze an existing chemical reactor on relevant issues such as the occurrence of hot-spot formation.

PROGRESS

The ongoing research has been on the LB implementation of a model which accounts for variable molecular masses in multi-component systems. The original implementation was found to be incorrect and a new implementation was proposed and validated for a 1D viscously damped standing wave and a 2D viscously damped Taylor-Green vortex. A journal publication will be submitted in Q1 2014. In Q2 2014 a journal publication will be submitted where the implementation will be used to simulate a 2D catalytic channel with in- and outflow and catalytic surface reactions and validate it with canonical results from literature. The research on spurious velocities is still pending.

DISSERTATIONS

-

SCIENTIFIC PUBLICATIONS

-

PROJECT AIM

The metabolic response of organisms in a fermentor depends on their environment, determined by the hydrodynamics, which may be spatially heterogeneous. The aim is to develop a computational fluid/reaction dynamics model that captures this heterogeneity. The results will serve as an input for laboratory experiments designed to study organisms in an industrially relevant environment; which is very relevant for the design of industrial fermentors.

PROGRESS

Single phase stirred tank simulations set up, including simple glucose uptake kinetics. Frozen-flowfield and transient flowfield approach compared. For reliable particle tracking, a transient flow approach is required. Tracer particles added to the system, which probe local conditions: external concentrations can be monitored from particle reference frame; representative of 'organism timelines'. Metabolic network *Penicillium Chrysogenum* (model organism) simplified for computational purpose. Computational outline for more adding metabolic network kinetics, bound to particle position and history. Complex reaction model applied in simple MATLAB simulations. Development of FLUENT model ongoing. Experimental set-ups (ECUST) designed.

DISSERTATIONS

-

SCIENTIFIC PUBLICATIONS

-

PROJECT LEADERS

RF Mudde

RESEARCH THEME

Mathematical and computational methods for fluid flow analysis

PARTICIPANTS

C Haringa

COOPERATIONS

ECUST Shanghai, DSM,
Neil Tang MSc. (PhD/ECUST)
Prof. Henk J. Noorman (TUD, DSM)
Prof. Ju Chu (ECUST)
Dr. Jianye Xia (ECUST)
Prof. Joseph J. Heijnen (TUD)
Dr. Walter M. van Gulik (TUD)
Prof. Matthias Reuss (Univ. Stuttgart)
Dr. Wouter van Winden (DSM)
Dr. Amit T. Deshmukh (DSM)

FUNDED

NWO/MoST-Hé, DSM
University -
FOM -
STW -
NWO Other 50 %
Industry 50 %
TNO -
GTI -
EU -
Scholarships -

START OF THE PROJECT

2013

INFORMATION

C Haringa
015 278 7084
c.haringa@tudelft.nl
cheme.nl/TP

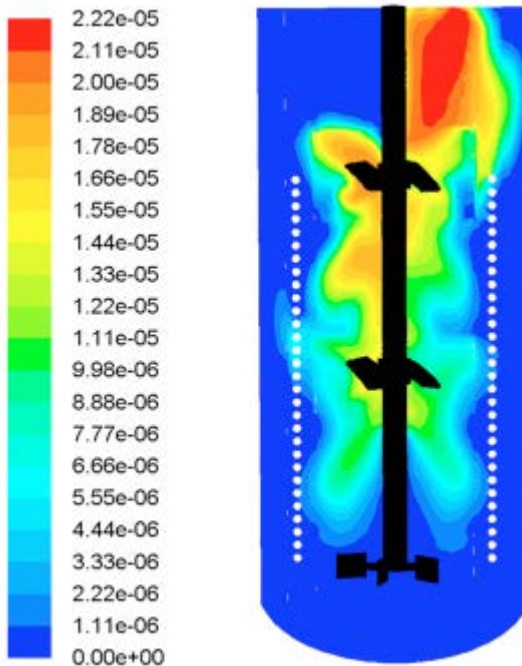

Distribution of glucose uptake rate [mol/l*s] in an industrial fermentor, generated in FLUENT.

MODELING THE DYNAMIC BEHAVIOUR OF REACTING COMPLEX FLUIDS IN NANOPORES WITH INTEGRATED CAHN-HILLIARD-NAVIER-STOKES SOLVER

PROJECT LEADERS

CR Kleijn, MT Kreutzer, V van Steijin

RESEARCH THEME

Complex structures of fluids

PARTICIPANTS

H Pimpalgaonkar

COOPERATIONS

Shell

FUNDED

FOM-NWO, Shell
University -
FOM 50 %
STW -
NWO Other -
Industry 50 %
TNO -
GTI -
EU -
Scholarships -

START OF THE PROJECT

2013

INFORMATION

H Pimpalgaonkar
015 278 7084
H.G.Pimpalgaonkar@tudelft.nl

PROJECT AIM

The aim of the project is to provide a fundamental understanding of kinetics and dynamics of multiphase flows inside nanopores. In particular, we are interested in how the immiscible products of a reaction can escape the nanopores. Application of interest here will be Fischer-Tropsch synthesis. These insights and models will make it possible to optimize new strategies for controlling and optimizing reactive multiphase process catalysts, leading to increased productivity, selectivity and catalyst life.

PROGRESS

This project has started in October 2013. A coupled Cahn-Hilliard - diffusion solver and a coupled Cahn-Hilliard - flow solver have been developed and are being tested with standard cases for which an analytical solution is known. Also an extensive literature survey is being done.

DISSERTATIONS

-

SCIENTIFIC PUBLICATIONS

-

Diffusion simulations showing phase separation from a random concentration as initial condition

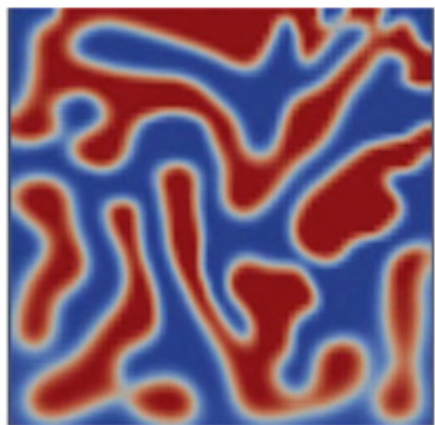
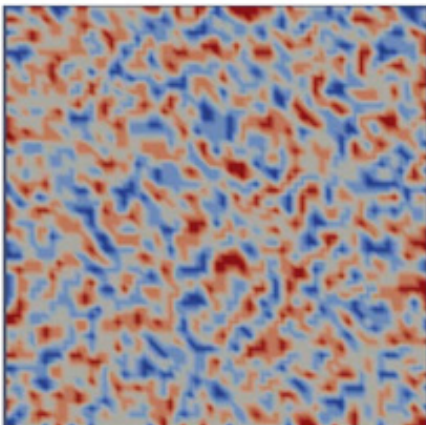



Prof.dr.ir. MT Kreutzer

The Product and Process Engineering (PPE) of the ChemE department of TU Delft views chemical engineering as an expanding field full of opportunities to create devices, processes and products. With expertise in reaction engineering, fluid mechanics and transport phenomena, we create solutions for soft-matter, nanotechnology, energy and lab-on-chip applications, often together with chemistry, physics and life-science groups. For us, engineering implies out-of-the-box thinking and design, from a sound basis in natural sciences with mathematics rigor. We are interested both in computational approaches and experimental work.

An important part of our work – led by Michiel Kreutzer – is related to the flow of droplets and bubbles in microchannels, with the aim of doing fun chemistry inside or outside those drops and bubbles. Each droplet can be seen as a miniaturized reactor that moves through a network on a chip as would a test tube through a chemistry lab. These flows are laminar, but the free interfaces bring in nonlinearities and instabilities, often driven by surface tension. Much of this work is done in cooperation with the group of prof. Chris Kleijn. There are lots of interesting chemistries that we deal with, ranging from catalysis to immiscible polymers.

Volkert van Steijn explores the use of aqueous polymer solutions to form droplets in an environment free of organic solvents and surfactants. Such droplets offer great potential for biomedical applications as they are fully biocompatible. In addition, he investigates the possibilities of using microfluidic devices for cell cultures.

Pouyan Boukany uses nanofluidics-based devices for providing quantitative insights into the fundamental mechanism of drug delivery, disease treatment, gene therapy and response of individual cells to therapeutic/ biomolecular reagents. In addition, he aims to understand the molecular dynamics of complex fluids using DNA as a model and advanced visualization techniques.

Ruud van Ommen is devoting an important part of his research efforts to dense gas-solid flows, where the solid phase consists of nanoparticles. In these systems, the nanoparticles cluster to form large, high-porosity agglomerates with fascinating interactions and flow properties. The aim is to chemically coat all individual nanoparticles in these agglomerates. He also studies gas-solid fluidized beds and three-phase systems with micron-sized particles, especially monitoring and structuring of these systems.

CONTINUOUS-FLOW SYNTHESIS OF CORE-SHELL NANOPARTICLES

PROJECT AIM

The aim of the project is to synthesize monodisperse core-shell nanoparticles with pre-defined properties, understand factors influencing the morphology (size, shape and dispersity), as well as applied these nanoparticles in catalysis.

PROGRESS

Progress in fabrication of microfluidic devices with well-established mixing, injection, cooling rate, multiple temperature zones for reactions carried out in compartments (droplets) dispersed in unreactive oils. We developed 2-layered PDMS devices for precise injection of fluid into moving droplets in order to synthesize Au-Ag core-shell nanoparticles with controlled shell thickness. Initial results of the synthesis of Au-Ag nanoparticles in microreactors shows that the coating of Au nanoparticles is improved in comparison with a batch mode synthesis. Progress was made also in modeling of the nucleation and growth of gold-citrate nanoparticles involving implementation of population balance into the model.

DISSERTATIONS

-

SCIENTIFIC PUBLICATIONS

-

PROJECT LEADERS

JR van Ommen, F Kapteijn,
MT Kreutzer

RESEARCH THEME

Complex dynamics of fluids

PARTICIPANTS

B Kampa, V van Steijn

COOPERATIONS

Catalysis Engineering group of
ChemE, TU Delft

FUNDED

| | |
|----------------|-------|
| NRSC-Catalysis | |
| University | - |
| FOM | - |
| STW | - |
| NWO Other | 100 % |
| Industry | - |
| TNO | - |
| GTI | - |
| EU | - |
| Scholarships | - |

START OF THE PROJECT

2009

INFORMATION

BM Kampa
015 278 8188
b.m.kampa@tudelft.nl
www.cheme.tudelft.nl/ppe

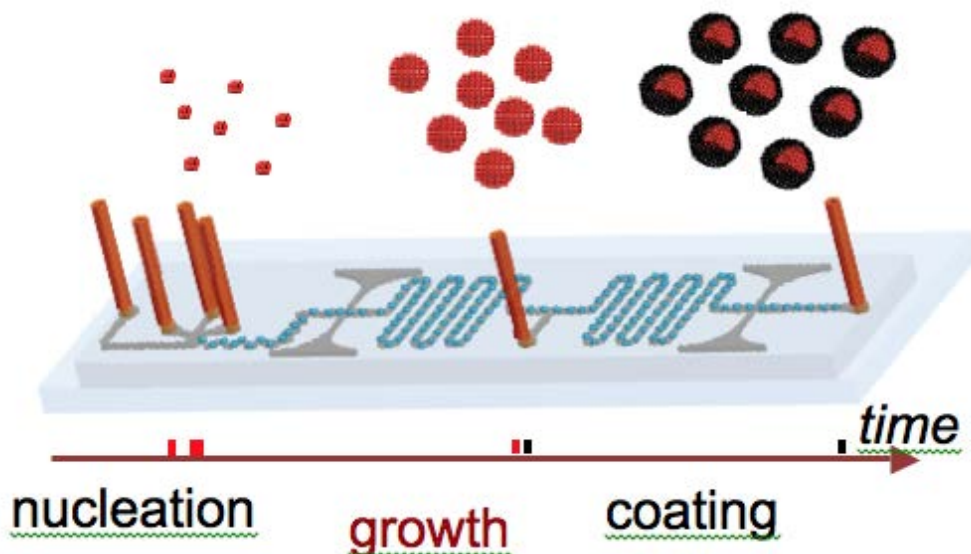

DYNAMIC BEHAVIOR OF TAYLOR FLOW IN DISTRIBUTED MICROREACTOR CHANNEL NETWORKS FOR LARGE-SCALE PROCESSING

PROJECT LEADERS

CR Kleijn, MT Kreutzer

RESEARCH THEME

Complex dynamics of fluids

PARTICIPANTS

Duong Anh Hoang

COOPERATIONS

TU Eindhoven (J.C. Schouten),
Wageningen University (K. Schroen)
OSPT-IROP (DSM, Shell, DOW,
Akzo-Nobel, Unilever, TNO)

FUNDED

STW, OSPT-IROP IROP (DSM,
Shell, DOW, Akzo-Nobel, Unilever,
TNO)

University -

FOM -

STW -

NWO Other 75 %

Industry 25 %

TNO -

GTI -

EU -

Scholarships -

START OF THE PROJECT

2009

INFORMATION

CR Kleijn

015 278 2835

C.R.Kleijn@TUDelft.NL

www.msp.tudelft.nl

DA Hoang

015 278 7084

h.a.duong@tudelft.nl

http://www.cheme.tudelft.nl

Simulations of a droplet arriving at a microfluidic T-junction: (1) symmetric breakup; (b) asymmetric breakup; (c) drifting

PROJECT AIM

Segmented flow is widely used in microreactor (Process-on-a-Chip and Lab-on-a-Chip) technology because of its high mass transfer, low axial dispersion and rapid micromixing. The generation and control of segmented flow in a single microchannel is well-established. Numbering up towards large-scale processing, however, required techniques for the stable and controlled distribution of segmented flows over networks of channels. As yet, techniques and fundamental understanding of such distributions are limited. In this project, we study the generation and transport of droplets and bubbles in microfluidic networks that comprise a large number of parallel microchannels. The aim is to understand how to form and distribute streams of bubbles or droplets in such networks.

PROGRESS

- Studied the dynamics of droplet breakup in microfluidic T-junctions using 3-D numerical simulations.
- Formulated general design and scale-up rules for a breakup-based Taylor flow distributor for multiple microreactors.

DISSERTATIONS

1. D.A. Hoang, "Breakup of confined droplets in microfluidics", TU Delft, October 16, 2013.

SCIENTIFIC PUBLICATIONS

1. D. A. Hoang, L. M. Portela, C. R. Kleijn, M. T. Kreutzer and V. van Steijn, "Dynamics of droplet breakup in a T-junction", *J. Fluid Mechanics* 717, R4 (2013), paper #R4.
2. Duong A Hoang, Volkert van Steijn, Luis M. Portela, Michiel T. Kreutzer, Chris R. Kleijn, "Benchmark numerical simulations of segmented multiphase flows in microchannels using the Volume of Fluid method", *Computer & Fluids*, 86, (2013) pp. 28–36.
3. Hoang, AD, Steijn, V van, Portela, L, Kreutzer, MT & Kleijn, CR, "Confined droplets at T-junctions", *Proceedings 2013 AIChE Annual Meeting*, San Francisco, CA (pp. 1-1).

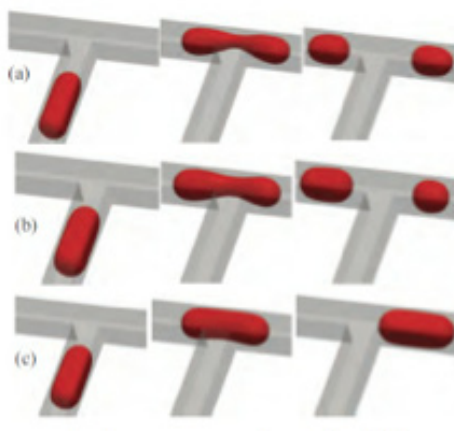

PROCESS INTENSIFICATION OF FISCHER-TROPSCH SYNTHESIS IN TUBULAR FIXED BED REACTORS

PROJECT AIM

We aim to significantly intensify the Fischer-Tropsch (FT) process in tubular fixed bed reactors. We do this by replacing the conventional randomly dumped catalyst packing with structured catalytic packing elements. The structures guide the multiphase flow through a channel network that can be described with several geometric parameters, which are chosen to optimally facilitate the FT reaction.

PROGRESS

We conducted the following experimental studies of multiphase flow through structured packing elements:

- The liquid residence time distribution
- The liquid flow distribution
- Liquid flow paths in a pseudo-2D transparent set-up

Compared to the conventional, randomly dumped beds, structured packings yield: (1) a shorter (decoupled) catalyst diffusion length, (2) much lower pressure drop, (3) much larger heat transport rates, and (4) an expanded window for reactor design and operating conditions.

DISSERTATIONS

-

SCIENTIFIC PUBLICATIONS

1. K. D. Kruit, D. Vervloet, F. Kapteijn and J. R. Van Ommen (2013). "Selectivity of the Fischer-Tropsch process: Deviations from single alpha product distribution explained by gradients in process conditions." *Catalysis Science and Technology* 3(9): 2210-2213.
2. D. Vervloet, F. Kapteijn, J. Nijenhuis and J. R. Van Ommen (2013). "A convection-based single-parameter model for heat transport in multiphase tubular reactors packed with closed cross flow structures." *Chemical Engineering Journal* 233: 265-273.
3. D. Vervloet, F. Kapteijn, J. Nijenhuis and J. R. Van Ommen (2013). "Process intensification of tubular reactors: Considerations on catalyst hold-up of structured packings." *Catalysis Today* 216: 111-116.

PROJECT LEADERS

JR van Ommen, F Kapteijn

RESEARCH THEME

Complex dynamics of fluids

PARTICIPANTS

D Vervloet, J Nijenhuis

COOPERATIONS

-

FUNDED

| | |
|--------------|------|
| STW | |
| University | - |
| FOM | - |
| STW | 75 % |
| NWO Other | - |
| Industry | 25 % |
| TNO | - |
| GTI | - |
| EU | - |
| Scholarships | - |

START OF THE PROJECT

2007

INFORMATION

JR van Ommen

015 278 2133

J.R.vanOmmen@tudelft.nl

<http://cheme.nl/ppe/people/vanommen.shtml>

PROJECT LEADERS

RF Mudde, JR van Ommen,
PJ Hamersma

RESEARCH THEME

Complex dynamics of fluids

PARTICIPANTS

N Hooshyar

COOPERATIONS

-

FUNDED

| | |
|--------------|-------|
| TU Delft | |
| University | 100 % |
| FOM | - |
| STW | - |
| NWO Other | - |
| Industry | - |
| TNO | - |
| GTI | - |
| EU | - |
| Scholarships | - |

START OF THE PROJECT

2008

INFORMATION

RF Mudde
015 278 2834
r.f.mudde@tudelft.nl

PROJECT AIM

To develop a strategy that allows structuring (in time or space) of slurry bubble columns.

PROGRESS

We have investigated the rise velocity of a single bubble in a neutrally buoyant suspension of particles in a liquid. The particles used ranged in size from 78 micron to four mm. The smallest particles have a Stokes number well below 1, while the largest ones have Stokes numbers well above 1. We show that the case with Stokes number smaller than one can be treated as a pseudo single phase liquid. The particles merely enhance the viscosity and the standard correlations for estimating the bubble rise velocity apply. In case the particle Stokes number is higher than one, the particles literally collide with the rising bubble. Here a mean free path analysis in combination with an estimate of the energy transfer from the bubble to the colliding particle provides a description of the motion of the bubble. From this the average bubble rise velocity is obtained.

DISSERTATIONS

1. N. Hooshyar, "Hydrodynamics of structured slurry bubble column reactors", TU Delft, January 14th 2013.

SCIENTIFIC PUBLICATIONS

1. Hooshyar, N., Van Ommen, J.R., Hamersma, P.J., Sundaresan, S. and Mudde, R.F., Dynamics of single rising bubbles in neutrally buoyant liquid-solid suspensions, Phys. Rev. Letters, 110 (24), no. 244501, 2013.

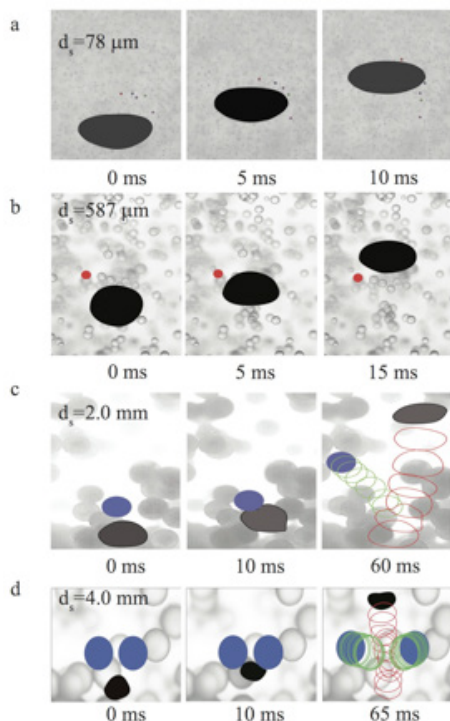

PROJECT AIM

The goal of this project is to develop design rules for multiphase slurry photocatalytic reactors, by integrating optics and hydrodynamics. Our objective is to develop simple analytical expressions to predict the quantum efficiency and teach the optimum operating conditions for measuring kinetic data and photonic efficiencies in such reactors. Based on simplified mathematical modeling, we aimed to study photon losses at different chain of photocatalytic events, investigate the effect of scattering by bubbles on the photoreaction rate in bubbly slurry photoreactors, and analyze diffusion limitations in such reactors.

PROGRESS

We quantified the local rate of photon absorption and photon losses in different steps of a photocatalytic reaction. To achieve this, we used a 1D description of optics in multiphase photocatalytic reactors, considering both low and high light intensities, leading to a linear and square root dependence of reaction rate on the local volumetric rate of photon absorption, respectively. We further studied the effect of introducing bubbles in slurry photocatalytic reactors on the scattering of photons and the eventual rate of photon absorption by photocatalytic particles. We quantified the threshold for the gas fraction that results in a noticeable (>5%) loss of photons due to scattering. Additionally, we studied diffusion limitations caused by the gradient in the rate of photon absorption in slurry photocatalytic reactors and reported the circumstances at which diffusion limitations can hinder accurate kinetic measurements.

DISSERTATIONS

1. M. Motegh, "Design of photocatalytic reactors", TU Delft, October 30th 2013.

SCIENTIFIC PUBLICATIONS

1. M. Motegh, J.R. van Ommen, P. W. Appel, R. F. Mudde and M. T. Kreutzer (2013). "Bubbles scatter light, yet that does not hurt the performance of bubbly slurry photocatalytic reactors." *Chemical Engineering Science* 100: 506-514.

PROJECTLEADERS

JR van Ommen, PW Appel,
MT Kreutzer

RESEARCHTHEME

Mathematical and computational
methods for fluid flow analysis

PARTICIPANTS

M Motegh

COOPERATIONS

-

FUNDED

| | |
|--------------------------------|-------|
| Delft University of Technology | |
| University | 100 % |
| FOM | - |
| STW | - |
| NWO Other | - |
| Industry | - |
| TNO | - |
| GTI | - |
| EU | - |
| Scholarships | - |

START OF THE PROJECT

2009

INFORMATION

JR van Ommen
015 278 2133

J.R.vanOmmen@tudelft.nl
<http://cheme.nl/pppe/people/vanommen.shtml>

Overall photonic efficiency in slurry photocatalytic reactors vs. dimensionless photons flux

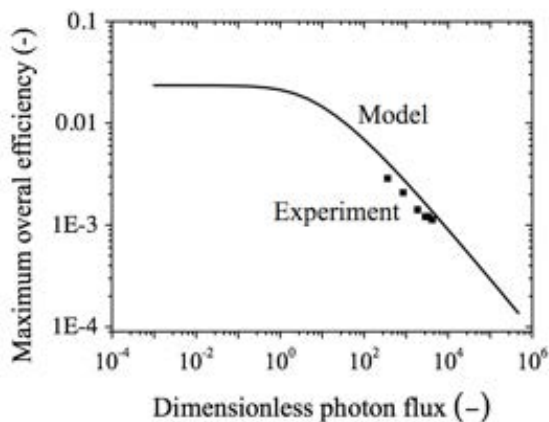

CHARACTERIZING NANOPARTICLE AGGLOMERATION IN THE GAS-SOLID FLOWS

PROJECT LEADERS

JR van Ommen

RESEARCH THEME

Complex dynamics of fluids

PARTICIPANTS

L de Martín

COOPERATIONS

WG Bouwman, Andrea Fabre

FUNDED

ERC Starting Grant

University -

FOM -

STW -

NWO Other -

Industry -

TNO -

GTI -

EU 100 %

Scholarships -

START OF THE PROJECT

2012

INFORMATION

JR van Ommen

015 278 2133

J.R.vanOmmen@tudelft.nl

cheme.nl/ppe/people/vanommen.

shtml

PROJECT AIM

Understanding and controlling the agglomerating nature of nanoparticles in gas flows during coating, such that uniform coatings can be made.

Characterizing the agglomerates formed by the nanoparticles by means of fractal analysis. Unraveling the mechanism of formation and breaking of the agglomerates in the fluidized bed.

PROGRESS

We have shown that the agglomerates of nanoparticles are built up in three hierarchical level, each level having a distinct fractal dimension. We characterized the two smaller levels (up to $\sim 10 \mu\text{m}$) by means of spin-echo small angle neutron scattering. The largest scale (up to the full agglomerate size, $\sim 200 \mu\text{m}$) was characterized using a newly developed settling tube. Moreover, we proposed a model to model the van der Waals interaction between two agglomerates taking into account the properties of the nanoparticles (such as having a polar or apolar surface) and the fractal dimension of the agglomerates. Finally, we developed a methodology for faster simulations of Diffusion Limited Aggregation, a model for nanoparticle agglomeration.

DISSERTATIONS

-

SCIENTIFIC PUBLICATIONS

1. L. De Martiñ, L. and J. R. Van Ommen (2013). "A model to estimate the size of nanoparticle agglomerates in gas-solid fluidized beds." Journal of Nanoparticle Research 15(11).
2. M. Tahmasebpoor, L. De Martiñ, M. Talebi, N. Mostoufi and J. R. Van Ommen (2013). "The role of the hydrogen bond in dense nanoparticle-gas suspensions." Physical Chemistry Chemical Physics 15(16): 5788-5793.

Fractal scaling of agglomerates of 20 nm nanoparticles

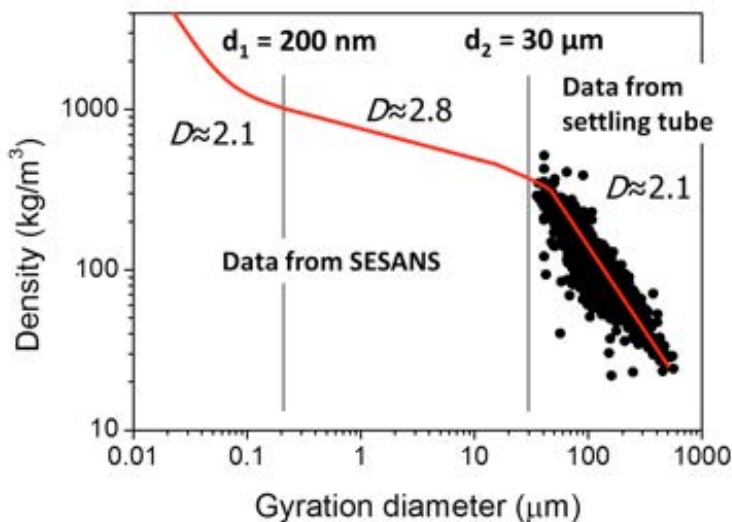

ELUCIDATING THE PHYSICS OF NANOPARTICLE INTERACTION AND CLUSTER DYNAMICS

PROJECT AIM

The aim is to investigate the interaction between individual nanoparticles, simple agglomerates and complex agglomerates. There will be a focus on the effect of surface modification on the previously studied interactions, and the development of techniques for efficient use of nanopoders from the acquired knowledge.

PROGRESS

Experimental and theoretical analysis of the fluidized agglomerate structure, focused on the fractal dimension, based on videos of free falling agglomerates in a fluidized bed. Simulations on agglomerate focusing for collision experiments. Finalized designs of experiments to study the properties, morphology, and behavior of fluidized agglomerates. Collision experiments, elasticity test, and 3D agglomerate imaging are in process.

DISSERTATIONS

-

SCIENTIFIC PUBLICATIONS

-

PROJECT LEADERS

JR van Ommen, MT Kreutzer

RESEARCH THEME

Complex dynamics of fluids

PARTICIPANTS

A Fabre, W Jin, F Grillo

COOPERATIONS

School of Energy and Environment,
Southeast University, Nanjing, PR
China

FUNDED

European Research Council (ERC)
University -
FOM -
STW -
NWO Other -
Industry -
TNO -
GTI -
EU 100 %
Scholarships -

START OF THE PROJECT

2012

INFORMATION

JR van Ommen

015 278 2133

J.R.vanOmmen@tudelft.nl

cheme.nl/ppe/people/vanommen.

shtml

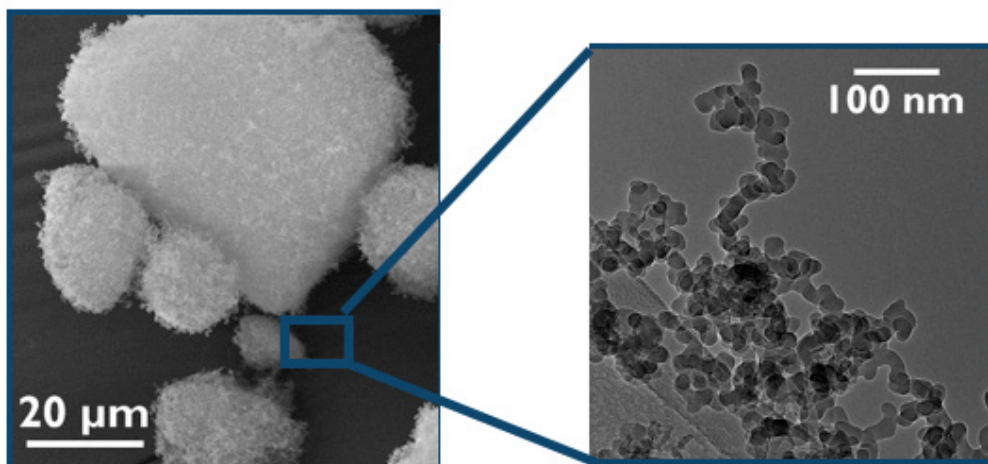

COATING FINE PARTICLES WITH ULTRATHIN FILMS USING ATOMIC LAYER DEPOSITION IN FLUIDIZED BED REACTORS

PROJECT LEADERS

JR van Ommen, GMH Meesters,
MT Kreuzer

RESEARCH THEME

Complex dynamics of fluids

PARTICIPANTS

D Valdesueiro, A Goulas

COOPERATIONS

-

FUNDED

Marie Curie ITN program and DSM

University -

FOM -

STW -

NWO Other -

Industry 25 %

TNO -

GTI -

EU 75 %

Scholarships -

START OF THE PROJECT

2011

INFORMATION

D Valdesueiro

015 278 9111

d.valdesueiro@tudelft.nl

PROJECT AIM

The goal of the project is the production of core-shell micron-sized particles, by using the coating technique called Atomic Layer Deposition (ALD). ALD can provide particles with thin layers. This process is carried out in a fluidized bed reactor. The particles are coated with two different aims. The first is to protect the core particle from degradation via e.g. oxidation or dissolution. The second one is to activate the surface of the particles by depositing valuable materials, such as a catalyst.

PROGRESS

We have worked on the optimization of the fluidization process, which is hindered by the tendency of the fine particles to form agglomerates. By using an external input of energy in form of mechanical vibration, microjet or mechanical agitation, the interparticle attractive forces, i.e. van der Waals interaction, can be overcome. We produced batches of core-shell structured material by depositing a layer of aluminum oxide by ALD, using trimethyl aluminum and water as gas-phase precursors. Further work will be aimed at studying the properties of such a core-shell material, the chemistry of ALD at low temperature and atmospheric pressure, and at scaling-up the coating process.

DISSERTATIONS

-

SCIENTIFIC PUBLICATIONS

1. A. Goulas and J. R. Van Ommen (2013). "Atomic layer deposition of platinum clusters on titania nanoparticles at atmospheric pressure." *Journal of Materials Chemistry A* 1(15): 4647-4650.

TiO₂ nanoparticle coated with a thin film of alumina in a fluidized bed reactor. With this technology, large amounts of particles can be coated.

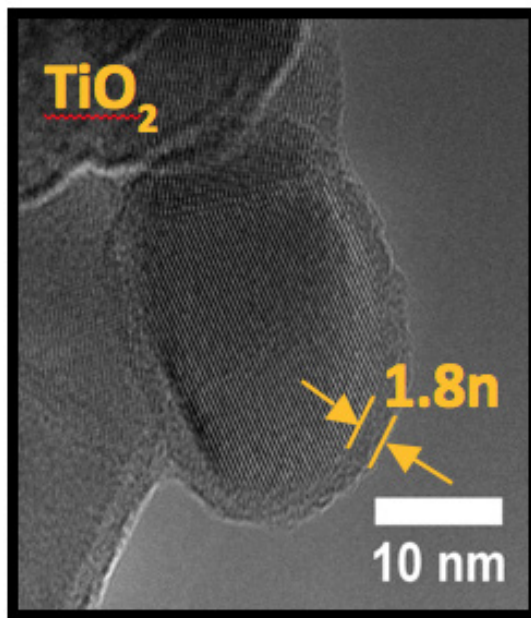

SIMULATION OF COATING OF NANOPARTICLES IN A FLUIDIZED BED

PROJECT AIM

The aim is to investigate the complex agglomerate dynamics and mass transfer phenomena in the fluidized bed reactor by numerical simulation. The challenge is to understand how nanoparticles agglomerate to loose dynamic clusters and understand the agglomeration process in gas flows during coating, such that uniform coatings can be made. Since the relevant length scales range from nm to cm, a multi-scale modeling approach will be required.

PROGRESS

Preliminary simulations for the drag on a single sphere in rarefied gas flow were conducted using OpenFOAM continuum CFD and DSMC methods. A literature review on the hydrodynamic force on clusters/agglomerates of nanoparticles at different flow regimes was produced. A literature review on the different numerical methods used in the fluidized bed simulation and agglomeration dynamics were conducted which lead to the conclusion that DSMC with bottom-up approach will be applied to our problem.

DISSERTATIONS

-

SCIENTIFIC PUBLICATIONS

-

PROJECT LEADERS

JR van Ommen, CR Kleijn

RESEARCH THEME

Mathematical and computational methods for fluid flow analysis

PARTICIPANTS

W Jin

COOPERATIONS

ASM, NanoNextNL

FUNDED

European Research Council (ERC)

University -

FOM -

STW -

NWO Other -

Industry -

TNO -

GTI -

EU 100 %

Scholarships -

START OF THE PROJECT

2012

INFORMATION

JR van Ommen

015 278 2133

J.R.vanOmmen@tudelft.nl

cheme.nl/ppe/people/vanommen.

shtml

Schematics of ALD on nanoparticles in a fluidized bed

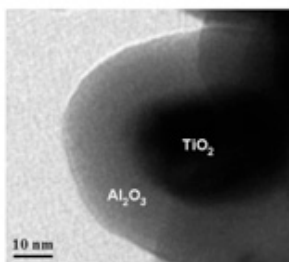

Hakim et al, *J. Am. Ceram. Soc.*, 89 3070-3075 (2006)

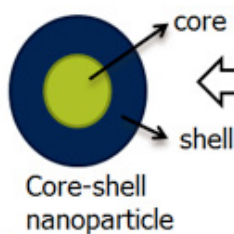

MULTIPHASE FLOW IN INTERNALLY STRUCTURED MICROCHANNELS UNDER PARTIAL WETTING CONDITIONS

PROJECT LEADERS

CR Kleijn, MT Kreutzer

RESEARCH THEME

Complex dynamics of fluids

PARTICIPANTS

M Musterd

COOPERATIONS

JM van Beek (UT), L Lefferts (UT),
Shell, DOW, ECN, Sulzer

FUNDED

ISPT

University -

FOM -

STW -

NWO Other -

Industry 100 %

TNO -

GTI -

EU -

Scholarships -

START OF THE PROJECT

2010

INFORMATION

M Musterd

015 278 7084

m.musterd@tudelft.nl

<http://cheme.nl/tp/musterd>

PROJECT AIM

In this project we aim to develop a CFD model to predict multiphase flow in micro- and millifluidic channels under partial wetting conditions. The partial wetting condition introduces additional fluids-solid interactions, which have a significant influence on the flow behaviour due to the dominance of capillary forces. A quantitative understanding of the fluids-solid interactions is of importance to accurately model the surface tension dominated multiphase flow. Therefore, the focus is on understanding and controlling the dynamics of the fluids-solid interface.

PROGRESS

To understand the complex interaction between a partially wetting liquid and a solid we have translated the two-phase micro/millifluidic system into a model system of a liquid droplet on an inclined solid substrate (see figure below). We use numerical and analytical energy minimization to study the deformation and onset of motion of the droplet. Important in the energy minimization is to correctly account for constraints on the motion of the contact line of the droplet. By taking the local nature of the constraints into account we can theoretically predict the evolution of the contact line of the droplet in good agreement with the numerical results which we experimentally validate. We find that families of droplets exist with equal volume and base width that all obtain the same shape at the onset of motion ($\alpha = \alpha_c$).

DISSERTATIONS

-

SCIENTIFIC PUBLICATIONS

1. Prediction of Droplet Deformation and Roll-off From an Inclined Plate, M. Musterd, V. van Steijn, C. R. Kleijn, and M.T. Kreutzer. In 1st Int. Workshop on Wetting and Evaporation: droplets of pure and complex fluids, 17-20 June 2013, Marseilles, 2013.
2. On the Fabrication of PDMS Micromodels by Rapid Prototyping, and Their Use in Two-Phase Flow Studies, N. K. Karadimitriou, M. Musterd, P. J. Kleingeld, M. T. Kreutzer, S. M. Hassanizadeh, and V. Joeekar-Niasar, Water Resources Research, 49 (4), p. 2056-2067, 2013.

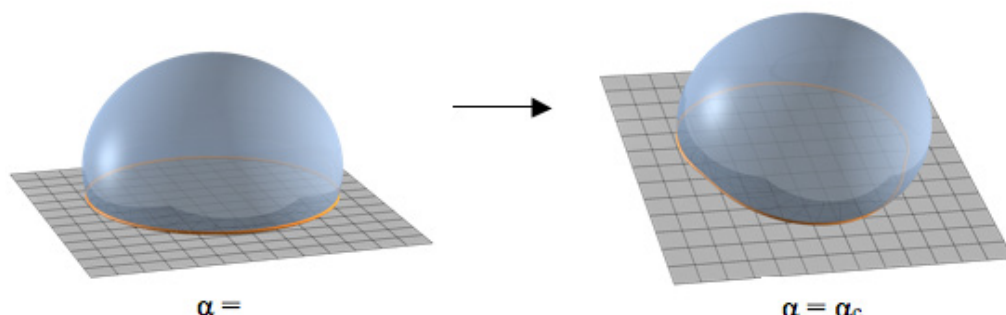

X-RAY TOMOGRAPHY APPLIED TO FLUIDIZED BEDS

PROJECT AIM

Study the hydrodynamics of various applications of fluidized beds using a fast X-ray tomographic system.

PROGRESS

We have been testing the use of Genetic Algorithms to reconstruct limited data sets that we obtained from our X-ray set up. We have shown that a so-called Adaptive Genetic Algorithm out performs the traditional SART reconstruction technique in finding small objects. Hence, using AGA increases the spatial resolution. On the other hand, AGA renders more erratic shapes than SART. Moreover, AGA is slow and requires too long reconstruction times. Our results suggest that a combination of SART and AGA may be better and combine the advantages of both methods. This is currently under investigation.

We have used our X-ray facility to investigate the dynamics of a spouted bed: a fluidized system in which a central gas jet is blown creating a central spout. We have measured several spout features and derived a particle circulation model from the data. We estimated the stability of the spout size and position for various flow conditions.

We have measured the flow pattern and dynamics of a downward micro-nozzle system for fluidized bed. This system is expected to assist the fluidization of nano-particles. The time-resolved gas distribution is obtained by our X-ray facility. A stable bubbling flow is found with this system from our recent results.

DISSERTATIONS

-

SCIENTIFIC PUBLICATIONS

1. Rautenbach, C., Mudde, R.F., Yang, X., Melaen, M.C., Halvorsen, B.M., A comparative study between electrical capacitance tomography and time-resolved X-ray tomography, *Flow Meas and Instr.*, 30, 34-44, 2013.

PROJECT LEADERS

RF Mudde, JR van Ommen

RESEARCH THEME

Mathematical and computational methods for fluid flow analysis

PARTICIPANTS

X Yang

COOPERATIONS

-

FUNDED

| | |
|--------------|-------|
| University | - |
| FOM | - |
| STW | - |
| NWO Other | - |
| Industry | - |
| TNO | - |
| GTI | - |
| EU | - |
| Scholarships | 100 % |

START OF THE PROJECT

2011

INFORMATION

RF Mudde

015 278 2834

r.f.mudde@tudelft.nl

MODELING THE DYNAMIC BEHAVIOUR OF REACTING COMPLEX FLUIDS IN NANOPORES WITH INTEGRATED CAHN-HILLIARD-NAVIER-STOKES SOLVER: APPLICATION TO FISCHER TROPSCH SYNTHESIS

PROJECT LEADERS

CR Kleijn, MT Kreutzer, V van Steijn

RESEARCH THEME

Complex dynamics of fluids

PARTICIPANTS

H Pimpalgaonkar

COOPERATIONS

Shell

FUNDED

FOM-NWO, Shell

University -

FOM 50 %

STW -

NWO Other -

Industry 50 %

TNO -

GTI -

EU -

Scholarships -

START OF THE PROJECT

2013

INFORMATION

H Pimpalgaonkar

015 278 7084

H.G.Pimpalgaonkar@tudelft.nl

PROJECT AIM

The aim of the project is to provide a fundamental understanding of kinetics and dynamics of multiphase flows inside nanopores. In particular, we are interested in how the immiscible products of a reaction can escape the nanopores. Application of interest here will be Fischer-Tropsch synthesis. These insights and models will make it possible to optimize new strategies for controlling and optimizing reactive multiphase process catalysts, leading to increased productivity, selectivity and catalyst life.

PROGRESS

This project has started in October 2013. A coupled Cahn-Hilliard - diffusion solver and a coupled Cahn-Hilliard - flow solver have been developed and are being tested with standard cases for which an analytical solution is known. Also an extensive literature survey is being done.

DISSERTATIONS

-

SCIENTIFIC PUBLICATIONS

-

Diffusion simulations showing phase separation from a random concentration as initial condition

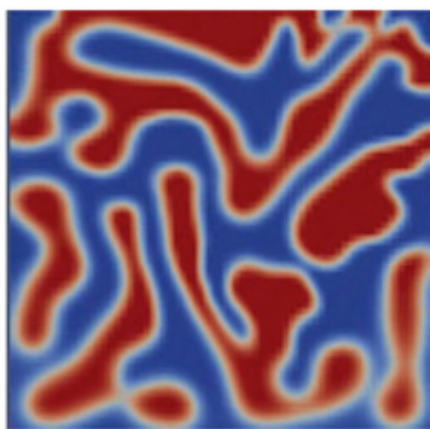
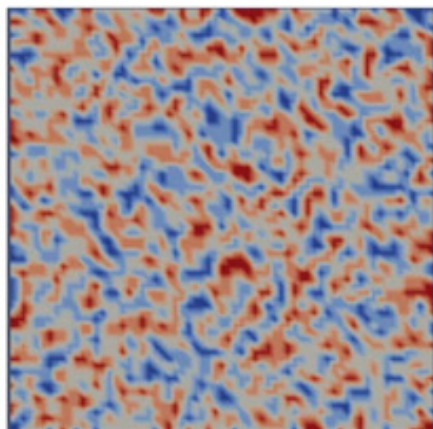



Prof.dr.ir. ThJJ van der Hagen

MISSION

The reactor physics department contributes to the development of sustainable nuclear energy such that it can play a major role in the global energy production. To this end, we focus on new and innovative nuclear reactors with improved efficiency, a high degree of safety, flexibility, and with a reduced waste production.

RESEARCH

Research in the department can be divided into three categories:

1. Thermal Hydraulics of Nuclear Reactors
 - ♦ Experimental research on stability of natural circulation Boiling Water Reactors with enhanced safety features.
 - ♦ Numerical analyses of thermal-hydraulic phenomena in new reactors like the SBWR and others. This also includes method and code development.
 - ♦ Thermo-Siphon research.
2. Reactor Physics Analysis of New Reactor Designs
 - ♦ VHTR: Design and analysis of a gas-cooled Very High Temperature Reactor for hydrogen production. Focus on core design and safety/transient analysis.
 - ♦ GCFR: Design and analysis of a Gas-Cooled Fast Reactor with a self-generating core and reduced waste production.
 - ♦ ADS: Dynamics analysis and development of reactivity measuring methods for Accelerator Driven Systems.
 - ♦ MSR: Design and Analysis of a Molten Salt Reactor with a high-conversion and/or breeding fuel cycle. Focus on core design, fuel cycle analysis, and dynamics and safety analyses.
 - ♦ Exotic designs, like the Fluidized Bed Reactor with a fast neutron spectrum, the CANDLE burnup reactor, and reactors for new applications.
3. Methods and Codes for Reactor Physics and Particle Transport
 - ♦ Development and application of electron-photon-neutron particle transport, possibly coupled to other codes like CFD.
 - ♦ Development and application of Monte Carlo transport methods possibly coupled to other codes like deterministic transport codes, and CFD.
 - ♦ Development and application of new reactor physics methods, like - mode calculations, coupled time-dependent neutronics and thermal-hydraulics, etc.
 - ♦ Development of methods to reduce leakage of nuclides from a geological disposal site.

INVESTIGATION OF HEAT TRANSFER TO TURBULENT SUPERCRITICAL FLUIDS BY MEANS OF DIRECT NUMERICAL SIMULATION

PROJECT AIM

Heat transfer to supercritical fluids shows exotic behaviour, due to sharp fluid property changes. As a result, it is difficult, if not impossible, to accurately predict heat transfer to such fluids. The goal of this project is to investigate the complex physics involved and to develop an accurate design correlation for the prediction of heat transfer to supercritical fluids. With Direct Numerical Simulations, it is possible to investigate the physics involved in great detail. These investigations will then be used for the design of a heat transfer relation.

PROGRESS

Last year, a 6th order precision finite difference/spectral code was developed to solve the low-Mach number Navier-Stokes equations in an annular geometry. The code was validated against experimental results (heat transfer to strongly heated air) with satisfactory results: mean statistics like velocity, temperature and the turbulent heat flux are in very good agreement. Preliminary simulations with heat transfer to supercritical carbon-dioxide proved to be unstable due to the sharp property gradients. This was solved by fixing a small number of bugs, implementing a different time discretization scheme, wall temperature relaxation and a limiter for the enthalpy. It is expected that this limiter is only necessary for coarse mesh simulations as the limiter is less active after each mesh refinement. The effects of the variable properties of a supercritical fluid on turbulence are currently under investigation. This is done by simulating a turbulent flow in a periodic annulus, in which the inner wall is kept at a temperature that is higher than the pseudo-critical temperature T_{pc} , while the outer wall is kept at a temperature lower than T_{pc} . Preliminary simulation results indicate that turbulent velocity fluctuations near the hot wall are dampened due to the lower viscosity and density, compared to a position further away from the hot wall. Although the shear increases near the hot wall, the turbulent shear stress decreases, which on average results in a lower production of turbulent kinetic energy compared to a fluid with constant fluid properties. The high mean value of the specific heat capacity c_p has a positive effect on the production of enthalpy fluctuations. Fluctuations of the specific heat capacity were found to decrease the total production of enthalpy fluctuations. This last result will likely change when T_{pc} is moved further away from the wall. A set of four different simulations is currently investigated in order to give a better picture how turbulence is affected by the variable properties of a supercritical fluid, by analyzing not only turbulence statistics, but also (small scale) structures.

DISSERTATIONS

-

SCIENTIFIC PUBLICATIONS

-

PROJECT LEADERS

M Rohde

RESEARCH THEME

Mathematical and computational methods for fluid flow analysis

PARTICIPANTS

JWR Peeters, BJ Boersma, R Pecnik, THJJ van der Hagen, M Rohde

COOPERATIONS

-

FUNDED

| | |
|--------------|-------|
| STW-OTP | |
| University | - |
| FOM | - |
| STW | 100 % |
| NWO Other | - |
| Industry | - |
| TNO | - |
| GTI | - |
| EU | - |
| Scholarships | - |

START OF THE PROJECT

2012

INFORMATION

JWR Peeters
015 278 6628
j.w.r.peeters@tudelft.nl
<http://pe.tudelft.nl/node/603>

HEAT TRANSFER IN NON-UNITY PRANDTL NUMBER FLOWS (PART OF THINS PROJECT)

PROJECT LEADERS

M Rohde

RESEARCH THEME

Complex dynamics of fluids

PARTICIPANTS

NGW Warncke, V Valori,

DW de Haas, P van der Baan,

M Rohde

COOPERATIONS

University of Pisa, PSI, KTH

FUNDED

Euratom (EU)

University -

FOM -

STW -

NWO Other -

Industry -

TNO -

GTI -

EU 100 %

Scholarships -

START OF THE PROJECT

2010

INFORMATION

N Warncke

015 278 3811

n.g.w.warncke@tudelft.nl

PROJECT AIM

The aim of the project is twofold: The primary goal is to understand turbulent heat transfer in a supercritical fluid, in particular the so-called Onset of Heat Transfer Deterioration due to a re-laminarizing boundary layer in an upward flow. The second aim is to study the effect of turbulent mixing in a supercritical fluid on the temperature fluctuations in walls (thermal fatigue).

PROGRESS

The experimental facility was finished end of 2013. It consists of a closed loop filled with supercritical Trifluoromethane at 57 bar, with an annular flow around a cylindrical heating rod in the rising section. At the end of 2013, several first flow measurements were done using LDA, showing a profile of the average velocities and Reynolds stresses. Improvements, however, are required. Most difficult hurdle to overcome is the refraction of light, which is difficult to predict due to the radial variation of the density. A ray-tracing script has been written that should determine the beam crossing as accurate as possible. First measurements show that this ray-tracing program performs reasonably well. Final measurements are to be expected in 2014. The facility on mixing of three parallel, supercritical jets in a plenum has been completed. First measurements are expected in May 2014.

DISSERTATIONS

-

SCIENTIFIC PUBLICATIONS

-

HEAT TRANSFER TO SUPERCRITICAL FLUIDS

PROJECT AIM

Study experimentally and theoretically heat transfer to supercritical fluids. The aim of the experimental study is to measure some relevant quantities characterizing the flow field (local velocities and their fluctuations within a plane and the Reynolds stress tensor calculated from them, for example); the experimental technique chosen to suit this purpose is Particle Image Velocimetry. The final aim of the project is to understand how the sharp change of properties around the critical point influences the flow field, the turbulence and the heat transfer effectiveness. This knowledge will be applied to improve existing turbulence models and heat transfer correlations.

PROGRESS

A Rayleigh-Benard set up has been designed with the aim to test experimental techniques in supercritical fluids (like Particle Image Velocimetry (PIV) and temperature measurements) and to study natural convection in SCFluids with a strongly turbulent regime. The set up is under construction.

The Ph.D. Candidate has been acquiring experience with PIV studying a Rayleigh Benard flow at non-Boussinesq conditions. She attended also a turbulence course organized by the Burgers Centrum. Moreover a mixing plenum to study the impingement of three supercritical jets has been constructing and it will be installed in a facility, which is already operative, in the coming months.

DISSERTATIONS

-

SCIENTIFIC PUBLICATIONS

-

PROJECTLEADERS

M Rohde

RESEARCHTHEME

Complex dynamics of fluids

PARTICIPANTS

V Valori, M Rohde, GE Elsinga, J Westerweel, THJJ van der Hagen

COOPERATIONS

-

FUNDED

| | |
|--------------|-------|
| STW | - |
| University | - |
| FOM | - |
| STW | 100 % |
| NWO Other | - |
| Industry | - |
| TNO | - |
| GTI | - |
| EU | - |
| Scholarships | - |

START OF THE PROJECT

2013

INFORMATION

V Valori
015 278 6821
v.valori@tudelft.nl



Prof.dr.ir. H Bijl



Prof.dr. F Scarano



Prof.dr.ir. PG Bakker

The research in the Aerodynamics Group involves fundamentals of Fluid Dynamics and its applications to aerodynamic problems of relevance in Aerospace Engineering systems.

The activities cover boundary layer research in low speed and high-speed flows, including re-entry aero-thermodynamics, complex unsteady flows, fluid-structure interaction problems and aeroacoustics.

The group works in close connection with the Wind Energy section for the investigation of rotor blade aerodynamics. Specific flow control strategies by passive (e.g. vortex generators) and active means (suction, plasma actuators) are explored for their application in flow transition and separation delay.

The experimental research is supported by the Aerodynamics Laboratories, which cover flow simulation range from incompressible to hypersonic regime. Emphasis is given to the development and application of image based advanced flow diagnostic techniques like Tomographic PIV, Background Oriented Schlieren, InfraRed Thermography.

The study of Fluid-Structure interactions and of unsteady flow simulation drive the development of efficient simulation tools for 3D-unsteady viscous flows (e.g. adaptive meshing, mimetic methods, multiscale computation of turbulence). Applications range from flapping wings and micro aerial vehicle aerodynamics to aircraft flutter and unsteady loads on wind turbines. The research on CFD also covers quantification of uncertainties in aerodynamics problems simulation.

ANALYSIS OF FLAPPING-FLIGHT PROPULSION

PROJECT AIM

The project is a continuation of previous research on flapping-wing propulsion in the flight regime of insects ($Re \sim 100$ to 1000). The present interest lies in the particular application of experimental and computational analysis tools to investigate flapping-wing Micro Aerial Vehicles (MAVs). Specific challenges are the wing-wing interaction, the high amount of wing flexibility, and the higher Reynolds number regime ($10,000 - 100,000$) which requires transitional and/or turbulent flow modeling.

PROGRESS

Computational activities compare the relative performance for deforming mesh strategies (ALE) and IBM (immersed boundary methods). Specific topics that were investigated consider the interaction between single or biplane flapping wings and tail effects. Further activities were undertaken to extend the IBM approach for the simulation of 3D clap-and-fling wing interactions. The experimental work has two major fields of attention: 1) the study of generic aeroelastic phenomena relevant to MAV propulsion and 2) a more detailed characterization of the aerodynamics of the DeFly MAV itself (wake structure; forward flight regime). A wind tunnel study was directed towards the characterization of the DeFly flapping-wing vortex wake in forward flight configuration, using multiple-plane stereo-PIV. From the planar velocimetry data, a subsequent volumetric representation of the wake was obtained by means of a Kriging regression technique.

DISSERTATIONS

-

SCIENTIFIC PUBLICATIONS

1. F.M. Bos, B.W. van Oudheusden, H. Bijl: Radial basis function based mesh deformation applied to simulation of flow around flapping wings, *Computers and Fluids*, vol.79 (2013), pp. 167-177.
2. F.M. Bos, B.W. van Oudheusden, H. Bijl: Wing performance and 3-D vortical structure formation in flapping flight, *J. Fluids & Structures*, vol. 42, pp. 130-151.
3. W.B. Tay, H. Bijl, B.W. van Oudheusden: Biplane and tail effects in flapping flight, *AIAA Journal*, Vol. 51, No. 9, September 2013, pp. 2133-2146; doi: 10.2514/1.J052007.
4. W.B. Tay, B.W. van Oudheusden and H. Bijl: Numerical simulation of "X-wing" type biplane flapping wings in 3D using the Immersed Boundary Method (IBM), *EUROMECH / ERCOFTAC Colloquium 549 on Immersed Boundary Methods*, Leiden, The Netherlands, 17-19 June 2013, Book of Abstracts p.85-87.
5. W.B. Tay, M. Percin, B.W. van Oudheusden, H. Bijl, O. Cetiner, M.F. Unal: Numerical and experimental analysis of tandem flapping flight, 43rd AIAA Fluid Dynamics Conferences, 24-27 June 2013, San Diego, CA. AIAA-2013-2471.
6. M. Percin, J.H.S. de Baar, B.W. van Oudheusden, R.P. Dwight: Three-dimensional wake reconstruction of a flapping-wing MAV using a Kriging regression technique, 10th International Symposium On Particle Image Velocimetry – PIV13, Delft, The Netherlands, July 1-3, 2013.
7. S. Deng, B.W. van Oudheusden, B.D.W. Remes, M. Percin, H. Bijl, H.M. Ruijsink: Experimental Investigation of the Flapping Performance on "DeFly Micro", International Micro Air Vehicle Conference and Flight Competition (IMAV 2013), 17-20 Sept. 2013, Toulouse, France, 8 pp.

PROJECT LEADERS

H Bijl, BW van Oudheusden

RESEARCH THEME

Complex dynamics of fluids

PARTICIPANTS

WB Tay, M Percin, S Deng

COOPERATIONS

Univ. Lund, Univ. Michigan, AFRL

FUNDED

| | |
|--------------|------|
| STW | |
| University | - |
| FOM | - |
| STW | 75 % |
| NWO Other | - |
| Industry | - |
| TNO | - |
| GTI | - |
| EU | - |
| Scholarships | 25 % |

START OF THE PROJECT

2010

INFORMATION

BW van Oudheusden

015 278 5349

B.W.vanOudheusden@tudelft.nl

<http://www.tudelft.nl/>

PIV-BASED NON-INTRUSIVE DETERMINATION OF UNSTEADY AERODYNAMIC LOADS

PROJECT LEADERS

BW van Oudheusden, F Scarano,
FFJ Schrijer

RESEARCH THEME

Complex dynamics of fluids

PARTICIPANTS

D Ragni, K Lynch, S Nitti

COOPERATIONS

DNW, CNRS, DLR, Uni BW Munich,
University of Southampton, ONERA,
TU Berlin, Istanbul TU, Univ Calgary,
LaVision GmbH

FUNDED

| | |
|-------------------|------|
| EU FP-7 (NIOPLEX) | |
| University | 90 % |
| FOM | - |
| STW | - |
| NWO Other | - |
| Industry | - |
| TNO | - |
| GTI | - |
| EU | 10 % |
| Scholarships | - |

START OF THE PROJECT

2006

INFORMATION

BW van Oudheusden
015 278 5349
B.W.vanOudheusden@tudelft.nl
<http://www.tudelft.nl/>

PROJECT AIM

Novel non-intrusive experimental approaches are developed and applied to determine the in-field pressure, as well as the integral aerodynamic loads on objects, from flow velocity data measured with particle image velocimetry (PIV). This is achieved by combining the flow field information with basic momentum principles. Apart from looking at the fundamental principles (notably 3D flow effects) the project also addresses the development of practical procedures. Primary topics of interest are: robustness of computation algorithms, effect of boundary conditions, influence of temporal and spatial resolution, the extension to compressible flow conditions.

PROGRESS

- 1) Extension of PIV-based determination of mean pressure in a transonic base flow investigation with relevance to launcher-afterbody buffeting.
- 2) Theoretical study of PIV-based determination of instantaneous pressure in a transonic base flow, based on a numerical data set.
- 3) Successful submission and start of an FP-7 funded collaborative project (NIOPLEX) in this research area, coordinated by TU Delft, with an international consortium of 9 partners.

DISSERTATIONS

-

SCIENTIFIC PUBLICATIONS

1. B.W. van Oudheusden: PIV-based pressure measurement, Measurement Science & Technology, Vol. 24 (2013) 032001 (32pp).

NANOSECOND DIELECTRIC BARRIER DISCHARGE (NS-DBD) PLASMA ACTUATOR FOR ACTIVE FLOW CONTROL

PROJECT AIM

To find the physical flow actuation mechanism due to nanosecond plasma actuators. Understanding of the physical principals of flow actuation is needed in order to be able to control the effect. Eventually, a strategy of flow actuation will be designed and tested.

PROGRESS

Research is begun with observations of the effect in still air, and in a 5 to 10 m/s flow on a flat plate, where flow actuation was not required. With this approach it has been possible to find out that the ns-DBD plasma actuator's flow control authority relies on a thermal effect. Such thermal effect introduces into the field of motion a discontinuity that travels downstream and it is able to trigger naturally selected hydrodynamics instability of the flow field where it is applied within. Afterwards, application of the plasma technology on a backward facing step has revealed a frequency effect of the actuation mechanism. Such frequency effect has been studied and analyzed. So far, it has been possible to answer the two main questions about a nanosecond DBD plasma actuator's flow control capability: 1) optimum position and 2) optimum frequency in order to achieve a specific flow control task. Journal and Conference publications describing each the above topics have been submitted.

DISSERTATIONS

-

SCIENTIFIC PUBLICATIONS

1. G Correale & I Popov, A.Rakitin, A.Starikovskii, S.Hulshoff, L.Veldhuis Flow Separation Control on Airfoil With Pulsed Nanosecond Discharge Actuator 49th AIAA Aerospace Science Meeting Orlando, Florida, USA, 2011 awarded of best student paper award 2011.
2. Ilya Popov & G Correale, A Nikipelov, S Pancheshnyi, S Hulshoff, L Veldhuis, S Zaidi, A Starikovskiy, Experimental Study and Numerical Simulation of Flow Separation Control with Pulsed Nanosecond Discharge Actuator AIAA Papper, vol 572, 201.
3. T Michelis & G Correale, I Popov, LLM Veldhuis, M Kotsonis, S Hulshoff Disturbance introduced into a laminar Boundary Layer by a NS-DBD plasma actuator, 51st AIAA Aerospace Sciences Meeting, Grapevine, Texas, USA, 2013.

PROJECTLEADERS

M Kotsonis, G Correale

RESEARCHTHEME

Mathematical and computational methods for fluid flow analysis

PARTICIPANTS

G Correale

COOPERATIONS

-

FUNDED

Plasma Technology Development

B.V., TUDelft

University 40 %

FOM -

STW -

NWO Other -

Industry 60 %

TNO -

GTI -

EU -

Scholarships -

START OF THE PROJECT

2011

INFORMATION

G Correale

06 81351055

g.correale@tudelft.nl

PROJECT LEADERS

SJ Hulshoff, H Bijl

RESEARCH THEME

Mathematical and computational methods for fluid flow analysis

PARTICIPANTS

Lei Cheng, Linfeng Chen,
Ilya Popov, Peter Fick

COOPERATIONS

Andrey Starikovskiy, Princeton

FUNDED

| | |
|---|------|
| Chinese Scholarships Council (CSC), Plasma Technology Development B.V., STW, TUDelft University | 15 % |
| FOM | - |
| STW | 10 % |
| NWO Other | - |
| Industry | 25 % |
| TNO | - |
| GTI | - |
| EU | - |
| Scholarships | 50 % |

START OF THE PROJECT

2008

INFORMATION

S Hulshoff
015 278 9111
s.j.hulshoff@tudelft.nl

PROJECT AIM

To combine low-order physical and numerical modeling techniques to minimize the cost of simulating viscous flow control problems. This includes the goal-oriented optimization of basis functions, stabilization parameters, and adaptation. The problems considered include transition control via plasma actuators, near-wall turbulent flows and fluid-structure interactions.

PROGRESS

A semi-discrete approach to goal-oriented basis function optimization has been formulated and tested for linear and non-linear functionals of the Burgers equation. An approach to Goal-oriented stabilization parameter calibration for the Stokes equation and stochastically forced Burgers equation was also developed. Both approaches have proven to be effective, and are now being extended to turbulent channel flow. A thermodynamic model for NS-DBD actuators was developed and studied numerically. Simulation results employing the model compare favorably with both theory and experimental data. An adjoint-consistent interior-penalty DG method for non-linear elliptic problems has been developed and analyzed. A priori error estimates show the method can achieve the same convergence rates obtained for linear problems. Journal publications describing each the above topics have been submitted.

DISSERTATIONS

-

SCIENTIFIC PUBLICATIONS

1. G Correale, T Michelis, I Popov, LLM Veldhuis, M Kotsonis, S Hulshoff
Disturbance introduced into a laminar Boundary Layer by a NS-DBD plasma actuator, 51st AIAA Aerospace Sciences Meeting, Grapevine, Texas, USA, 2013.
2. Ilya Popov, Andrey Nikipelov, Sergey Pancheshnyi, Giuseppe Correale, Steven Hulshoff, Leo Veldhuis, Sohail Zaidi, Andrey Starikovskiy, Experimental Study and Numerical Simulation of Flow Separation Control with Pulsed Nanosecond Discharge Actuator AIAA Paper, vol 572, 201.

PROJECT AIM

Develop numerical methods to fuse data from experimental fluid dynamics with prior knowledge, (e.g., mathematical representations of physical laws) to obtain an estimate of the distribution of the true state of a process. The methods we develop are formulated from a Bayesian perspective in order to properly combine the uncertainties from both worlds.

PROGRESS

- Development of a reconstruction method that creates a divergence-free velocity field from volumetric velocity measurements using Gaussian process regression
- Development of a spatio-temporal filter that includes the vorticity equation and imposes the divergence-free condition in the reconstruction of volumetric velocity measurements of incompressible flows.

DISSERTATIONS

-

SCIENTIFIC PUBLICATIONS

-

PROJECT LEADERS

H Bijl, RP Dwight

RESEARCH THEME

Mathematical and computational methods for fluid flow analysis

PARTICIPANTS

I Azijli, R Dwight, H Bijl

COOPERATIONS

TNO, IIT MADRAS

FUNDED

| | |
|--------------|-------|
| TNO | |
| University | - |
| FOM | - |
| STW | - |
| NWO Other | - |
| Industry | - |
| TNO | 100 % |
| GTI | - |
| EU | - |
| Scholarships | - |

START OF THE PROJECT

2011

INFORMATION

I Azijli

015 278 4502

i.azijli@tudelft.nl

<https://aerodynamics.lr.tudelft.nl/~rdwight/index.html>

ADVANCES IMAGE ANALYSIS TECHNIQUES FOR PARTICLE IMAGE VELOCIMETRY AND PIV UNCERTAINTY ESTIMATORS

PROJECT LEADERS

F Scarano

RESEARCH THEME

Complex dynamics of fluids

PARTICIPANTS

A Sciacchitano, K Lynch

COOPERATIONS

LaVision GmbH, Univ Utah, LaVision US, Virginia Tech

FUNDED

European Research Council 50%

LaVision GmbH 50%

University -

FOM -

STW -

NWO Other -

Industry 100 %

TNO -

GTI -

EU -

Scholarships -

START OF THE PROJECT

2010

INFORMATION

F Scarano

015 278 5902

f.scarano@tudelft.nl

PROJECT AIM

Study of digital algorithms to increase the reliability and the dynamic range of velocity measurements by Particle Image Velocimetry. The work is based on the exploitation of time-sequences of 2D recordings or 3D reconstructions from tomographic PIV. Specific data analysis techniques are investigated to obtain a-posteriori error estimates from PIV experiments.

PROGRESS

A novel algorithm named Fluid Trajectory Correlation (FTC) has been conceived and studied in its performance relative to the image pair correlation approach. Results show that time series can be analyzed with 5-fold increase in dynamic range. The image-matching method has been introduced as a-posteriori estimator of PIV measurement uncertainty. A collaboration with Barton Smith (Univ Utah), Pavlos Vlachos (Virginia Tech) and Douglas Neal (LaVision US) has led to the realization of unprecedented experiments with simultaneous measurements at different dynamic range. Several methods currently in use for uncertainty estimation will be scrutinized on the basis of such experiments. A dedicated workshop has been organized with the research partners in conjunction with the upcoming Lisbon conference (2014).

DISSERTATIONS

-

SCIENTIFIC PUBLICATIONS

1. K Lynch, F Scarano, A high-order time-accurate interrogation method for time-resolved PIV, *Measurement Science and Technology* 24 (3), 035305.
2. K Lynch, F Scarano, Material Derivative Measurements in High-Speed Flows by Four-Pulse Tomographic PIV, 10th Int. Symp on PIV, Delft.
3. K Lynch, F Scarano, An experimental study of reconstruction accuracy using a 12-Camera Tomo-PIV system, 10th Int. Symp on PIV, Delft.
4. A Sciacchitano, F Scarano, B Wieneke, On the universality of PIV uncertainty quantification by image matching, 10th Int. Symp on PIV, Delft.
5. B Wieneke, A Sciacchitano, F Scarano, A super-resolution approach for uncertainty estimation of PIV measurements, *Bulletin of the American Physical Society* 57.

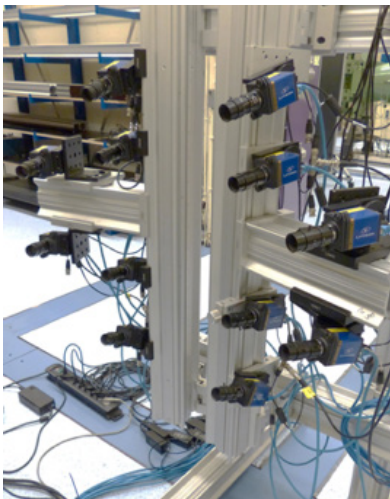

BAYESIAN ESTIMATES OF ERROR DUE TO RANS TURBULENCE MODELS

PROJECT AIM

To 1) quantify error introduced into RANS simulations by the turbulence closure model, and 2) devise predictive methods giving improved accuracy and adding uncertainty bounds. We investigate Bayesian approaches to take into account uncertainties in RANS turbulence models due to both uncertain closure coefficients, and uncertainty arising from the assumptions in their mathematical form. The first step consists of adapting and validating Bayesian theories, for uncertainty quantification of fundamental turbulent flows using a single turbulence model. Next, a general strategy for the quantification of modeling uncertainties will be proposed using Bayesian Model Averaging techniques, in which multiple turbulence models are combined in a single predictive scenario.

PROGRESS

We obtained estimates for the error in the Launder–Sharma k – ϵ turbulence closure model, for a limited class of flows. In particular we searched for estimates grounded in uncertainties in the space of model closure coefficients, for wall-bounded flows at a variety of pressure gradients. We performed 13 separate Bayesian calibrations – each at a different pressure gradient – using measured boundary-layer velocity profiles, and a statistical model containing a multiplicative model-inadequacy term in the solution space. The total solution uncertainty in the Quantity of Interest (QoI) was represented with a probability-box. Following that, we expanded our set of turbulence models and used Bayesian Model-Scenario Averaging to combine posterior coefficient distributions, calibrated for different models and scenarios, into a single stochastic estimate of the QoI in an unmeasured (prediction) scenario.

DISSERTATIONS

-

SCIENTIFIC PUBLICATIONS

1. W.N. Edeling, P. Cinnella, R.P. Dwight, H. Bijl, “Bayesian estimates of parameter variability in the k – ϵ turbulence model” *Journal of Computational Physics*, Volume 258, 2013.

PROJECT LEADERS

R Dwight, P Cinnella

RESEARCH THEME

Mathematical and computational methods for fluid flow analysis

PARTICIPANTS

W Edeling, R Dwight, P Cinnella

COOPERATIONS

Arts et Métiers-ParisTech, Delft University of Technology, ONERA Office National d'Etudes et de Recherches Aérospatiales

FUNDED

L'Agence National de le Recherche University -
FOM -
STW -
NWO Other -
Industry 100 %
TNO -
GTI -
EU -
Scholarships -

START OF THE PROJECT

2011

INFORMATION

R Dwight
015 278 5773
R.P.Dwight@tudelft.nl
<https://aerodynamics.lr.tudelft.nl/~rdwight/>

FLOVIST: FLOW VISUALIZATION INSPIRED AEROACOUSTICS BY TIME RESOLVED TOMOGRAPHIC PARTICLE IMAGE VELOCIMETRY

PROJECT LEADERS

F Scarano

RESEARCH THEME

Complex dynamics of fluids

PARTICIPANTS

M Novara, D Violato, S Ghaemi,
A Ianiro, S Pröbsting

COOPERATIONS

Nationaal Luchtvaart Lab. (NLR)
German Aerospace Centre (DLR)
LaVision GmbH, University of
Naples, University of Poitiers

FUNDED

European Research Council (ERC)
University -
FOM -
STW -
NWO Other -
Industry 100 %
TNO -
GTI -
EU -
Scholarships -

START OF THE PROJECT

2008

INFORMATION

F Scarano
015 278 5902
f.scarano@tudelft.nl

PROJECT AIM

The FLOVIST project aims at advancing Tomographic PIV and extend its use towards the aeroacoustic analysis of turbulent flows of relevance in aerodynamics. The research is based on a number of milestones: 1) feasibility of time-resolved tomographic PIV in air flows; 2) realization of 3D pressure field measurements; 3) combining pressure-from-PIV approach with aeroacoustic analogies; 4) application to tonal noise problems and to broadband emissions from boundary layers and airfoil trailing edges.

PROGRESS

Time resolved analysis of transitional jets. Experiments performed by high-resolution time-resolved tomographic PIV were performed on circular, chevron and swirled jets (collaboration with University of Naples), showing that Powell acoustic source can be identified and associated to specific flow events within the jet core disruption. Time-resolved Tomo-PIV in a turbulent boundary layer and evaluation of the pressure from PIV technique for pressure coherence evaluation (collaboration with UniRoma who provides a DNS simulations of the BL flow).

DISSERTATIONS

1. S. Ghaemi, Pressure fluctuations in the turbulent boundary layer: advances in diagnostics and control, TU Delft, Promoter F. Scarano.
2. M. Novara, Advances in tomographic PIV, TU Delft, Promoter F. Scarano
3. D. Violato, 3D flow organization and dynamics in subsonic jets – Aeroacoustic source analysis by tomographic PIV, TU Delft, Promoter F. Scarano.

SCIENTIFIC PUBLICATIONS

1. (Review article) F Scarano, Tomographic PIV: principles and practice, Measurement Science and Technology 24 (1), 012001.
2. S Ghaemi, F Scarano, Turbulent structure of high-amplitude pressure peaks within the turbulent boundary layer, Journal of Fluid Mechanics 735, 381-426
3. D Violato, F Scarano, Three-dimensional vortex analysis and aeroacoustic source characterization of jet core breakdown, Physics of Fluids (1994-present) 25 (1), 015112.
4. M Novara, F Scarano, A particle-tracking approach for accurate material derivative measurements with tomographic PIV, Experiments in fluids 54 (8), 1-12.
5. S Pröbsting, F Scarano, M Bernardini, S Pirozzoli, On the estimation of wall pressure coherence using time-resolved tomographic PIV, Experiments in fluids 54 (7), 1-15.
6. M Novara, A Ianiro, F Scarano, Adaptive interrogation for 3D-PIV, Measurement Science and Technology 24 (2), 024012.

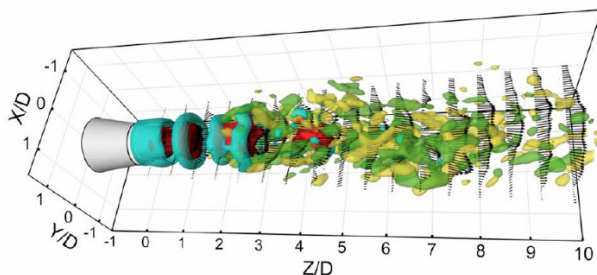

PROJECT AIM

Development and implementation of non-intrusive measurement techniques for high-speed compressible flows with special focus on particle image velocimetry. The measurement techniques are subsequently used to investigate flow phenomena that are pertinent to launchers, high-speed air transport systems and reentry vehicles. Specific topics that are studied are shockwave boundary layer interaction and control, compressible boundary layer transition and compressible baseflows.

PROGRESS

- 1) Investigation of flow control by means of micro-ramps of a Mach 2 shock wave boundary layer interaction.
- 2) Characterization of the far wake of a micro-ramp in a Mach 2 turbulent boundary layer
- 3) Study and control of transitional shock-wave boundary layer interactions (EU FP7 project TFAST)
- 4) Investigation of compressible and incompressible launcher baseflows using (TOMO) PIV and PIV based pressure integration.
- 5) Experimental investigation of (hypersonic) boundary layer transition using tomographic particle image velocimetry.

DISSERTATIONS

-

SCIENTIFIC PUBLICATIONS

1. Zhengzhong Sun, Fulvio Scarano, Bas W. van Oudheusden, Ferry J. J. Schrijer, Xiao Wang, Yonghua Yan, Chaoqun Liu: Numerical and Experimental Investigation of the Flow behind a Supersonic Micro-Ramp. 51st AIAA Aerospace Sciences Meeting, 7-10 Jan 2013, Dallas, Texas. AIAA-2013-0954.

R.H.M. Giepmans, F.F.J. Schrijer and B.W. van Oudheusden: Flow control of an oblique shock wave reflection with micro-ramp vortex generators: effects of location and size, 5th European Conference For Aeronautics And Space Sciences (EUCASS), July 1-5, 2013, Munich, Germany

F.F.J. Schrijer, A. Sciacchitano and F. Scarano: Transonic base-flow buffeting: characterization of the large scale flow unsteadiness using POD, 5th European Conference For Aeronautics And Space Sciences (EUCASS), July 1-5, 2013, Munich, Germany

Z. Sun, F. F. J. Schrijer, B. W. van Oudheusden, F. Scarano: Decay of the turbulent wake from the supersonic micro-ramp, TSFP-8, 28-30 Aug. 2013, Poitiers, France.

S. Marié, Ph. Druault and F.F.J. Schrijer, Experimental analysis of the pressure-velocity correlations of external unsteady flow over rocket launchers. Aerospace Science and Technology, 2013/30(1), 83-93.

PROJECT LEADERS

FFJ Schrijer, F Scarano,
BW van Oudheusden

RESEARCH THEME

Complex dynamics of fluids

PARTICIPANTS

Z Sun, K Lynch, R Giepmans,
V Gentile, Q Ye

COOPERATIONS

ESA, VKI, DLR, NLR, ASTRIUM,
TNO, ONERA, UNINA

FUNDED

| | |
|------------------------------|---|
| EU (TFAST), ESA (TRAV2), CSC | |
| University | - |
| FOM | - |
| STW | - |
| NWO Other | - |
| Industry | - |
| TNO | - |
| GTI | - |
| EU | - |
| Scholarships | - |

START OF THE PROJECT

2003

INFORMATION

F Schrijer
015 278 6386
f.f.j.schrijer@tudelft.nl

BLUFF BODY LEADING EDGE SEPARATION UNDER THE INFLUENCE OF STRONG PRESSURE GRADIENTS DUE TO OFFSET ELEMENTS: APPLICATION ON TRUCK SIDE-MIRRORS

PROJECT LEADERS

M Kotsonis

RESEARCH THEME

Complex dynamics of fluids

PARTICIPANTS

T Michelis

COOPERATIONS

DAF, CRF

FUNDED

EU, TUDelft

University 25 %

FOM -

STW -

NWO Other -

Industry -

TNO -

GTI -

EU 75 %

Scholarships -

START OF THE PROJECT

2013

INFORMATION

T Michelis

t.michelis@tudelft.nl

PROJECT AIM

Improving the aerodynamics of the side-view mirror of a truck for drag reduction, especially in side-wind conditions. A combination of active and passive flow control means will be developed and tested in a truck prototype under realistic driving conditions. The active flow control devices of choice are AC-DBD plasma actuators.

PROGRESS

Flow around a cylinder that is placed in proximity to the leading edge of an elongated bluff body has been characterized using time resolved Particle Image Velocimetry at Reynolds numbers in the order of 104. This experiment provided physical insight in the combination of two previously studied scenarios: (i) wall bounded cylinder; (ii) leading edge separation bubble from an elongated bluff body. Particle Image Velocimetry was implemented for measuring a full-scale mirror from DAF at Reynolds numbers in the order of 105. The experimental data is used for tuning the numerical solvers of DAF as well as for determining the base flow on which a suitable and realistic control technique will be applied.

DISSERTATIONS

-

SCIENTIFIC PUBLICATIONS

-



Prof.dr.ir. GS Stelling



Prof.dr.ir. WSJ Uijttewaal

The Environmental Fluid Mechanics Group performs fundamental, process-oriented research on fluid flow problems of practical relevance in water management, environmental engineering, hydraulic engineering and coastal engineering. To enhance the potential of practical applications, the section not only aims at writing publications, as far as scientific output is concerned, but also at the production of software that is available via internet. An example is the software package SWAN (Simulating Waves Nearshore). Free surface flow models based upon unstructured grids are in preparation and will be released in coming years. Within this philosophy the research program encompasses the following main items:

- Free surface waves with topics such as: Generation and prediction of squall oscillations and harbour seiches, dynamics of surf beat and the Wave model SWAN
- Shallow flows, transport and sedimentation with the following topics: turbulence and flow structures in rivers and its flood planes, stability and transport under waves and currents of rock elements in cover layers consisting of loose, granular material,
- Transport of suspended particulate matter with topics such as: advanced, experimental and numerical work concerning particle-turbulence interaction as well as flocculation and sedimentation processes
- Numerical model development with topics such as: development of the non-hydrostatic models for the investigation of dam breaks including inundations, short wave problems, near field plume discharges, stratified flows, and local scour near dams, unstructured grids via finite volume methods and finite element methods and development of large scale integrated 1d/2d rainstorm drainage/flooding model applicable to rural and urban areas.

EVOLUTION OF CLAY FLOC SIZES AS FUNCTION OF POLYMER TYPE, DOSAGE AND SHEAR STRESSES

PROJECT AIM

The aim is to link the physical properties of cohesive sediment to its chemical characteristics. In order to assess these properties the following measurements are performed: electrokinetic characterization of the surface charge, viscosity measurements, particle size distribution in time. Models are subsequently developed to link all these properties.

PROGRESS

The electrokinetic characterization of clays has led to 2 publications, one step has been achieved in the modelling (1 article published); the electroacoustic device build by our partners is currently tested. A large series of measurements as function of polymer dosage and shear stresses has been performed. We are now writing one publication about it.

DISSERTATIONS

1. Determination des propriétés de charge d'espèces en solution : analyse et mise au point d'une technique électroacoustique, PhD thesis UPMC (Paris).

SCIENTIFIC PUBLICATIONS

1. Comparison between the electrokinetic properties of kaolinite and montmorillonite suspensions. Tsujimoto, Y.; Chassagne C.; Adachi Y., J Colloid Int. Sci, 407, 109-115 (2013).
2. Dielectric and electrophoretic response of montmorillonite particles as function of ionic strength. Tsujimoto, Y.; Chassagne C.; Adachi Y., J Colloid Int. Sci, 404, 72-79 (2013).
3. Electrophoretic mobility of latex nanospheres in electrolytes: Experimental challenges. Chassagne, Claire; Ibanez, Maria, Pure and Applied chemistry, 85, 1, 41-51 (2013).
4. Dielectric response of a charged prolate spheroid in an electrolyte solution Chassagne, C ; Int. J of Thermodynamics, 34, 7, 1239-1254 (2013).

PROJECT LEADERS

C Chassagne

RESEARCH THEME

Complex structures of fluids

PARTICIPANTS

M Ibanez, C Chassagne

COOPERATIONS

PECSA, Université Paris-Sorbonne, Cordouan Tech., Deltares

FUNDED

Deltares, Allocation Nationale de Recherche (ANR)

| | |
|--------------|------|
| University | 25 % |
| FOM | - |
| STW | - |
| NWO Other | - |
| Industry | 50 % |
| TNO | - |
| GTI | - |
| EU | - |
| Scholarships | 25 % |

START OF THE PROJECT

2011

INFORMATION

C Chassagne

c.chassagne@tudelft.nl
www.citg.tudelft.nl/index.php?id=72915

SEDIMENT NOURISHMENT AS A SOLUTION TO AUTONOMOUS BED DEGRADATION OF THE RHINE RIVER : RESPONSE TO SEDIMENT OVERLOADING

PROJECT LEADERS

WSJ Uijtewaal, A Blom

RESEARCH THEME

Complex dynamics of fluids

PARTICIPANTS

C Orrú

COOPERATIONS

Dr Enrica Viparelli (University of South Carolina)

FUNDED

Cornelis Lely Stichting

Regional Government of Sardinia

(Italy) (Regione Autonoma della

Sardegna-Programma Master&Back)

University -

FOM -

STW -

NWO Other -

Industry 25 %

TNO -

GTI -

EU -

Scholarships 75 %

START OF THE PROJECT

2011

INFORMATION

C Orrú

015 278 4070

C.Orru@tudelft.nl

PROJECT AIM

The main goal is to provide insights on the development of the morphodynamic pattern of rivers dominated by bedforms with sand-gravel mixtures during unsteady conditions. More specifically we study the influence of the evolution of bedform geometry, stochastics of bedform geometry and sorting on morphodynamic changes. This will be reached by creating a new experimental data set for calibration of analytical and numerical models of morphodynamics of sand/gravel rivers. In the flume experiments we will focus on the response of the river bed to dredging and sediment nourishment.

PROGRESS

We developed and validated an image analysis technique for measuring the stratigraphy in the upcoming flume experiments. The method allows for characterizing the grain size distribution of the bed surface and the size stratification within the bed, with the aim of gaining new insights in grain size selective processes. The image analysis algorithm was improved leading to a much faster computation and a more robust analysis. The technique was validated during several new flume experiments to determine the stratigraphy of Gilbert delta deposits. The data analysis was aimed to compare the areal fraction results of the image analysis with the volumetric fraction results of sieve analysis and to find a proper model to convert the data. All the above mentioned progresses and results are presented on a scientific paper that is now under review. In addition, the work was committed on the design and program of the upcoming flume experiments.

DISSERTATIONS

-

SCIENTIFIC PUBLICATIONS

1. Orrú, C., Eleftherakis, D., Blom, A., Snellen, M., Uijtewaal, W.S.J., Simons, D.G. (2013). New laboratory techniques to determine the grain size distribution of a sand gravel bed surface and substrate. In G. Coco, B. Blanco, M. Olabarrieta, R. Tinoco (Eds.), Symposium on river, coastal and estuarine morphodynamics (pp. 174-174).
2. Orrú, C., Blom, A., Uijtewaal, W.S.J. (2013). Migration of a dredging trench: Bedform dominated flume experiments with a trimodal mixture. In A Crosato (Ed.), Book of abstracts NCR-Days 2013 Vol. 2013. NCR-Publicatie, (ISSN 1568-234X) (pp. 3-3-3-4). Delft: Nederlands Centrum voor Rivierkunde / UNESCO -IHE.
3. Orrú, C., Chavarrías, V., Uijtewaal, W.S.J., Blom, A.. Image analysis for measuring stratigraphy in sand-gravel laboratory experiments, Earth Surf. Dynam. Discuss., 1, 973-1018, doi:10.5194/esurf-d-1-973-2013, (2013).
4. Chavarrías, V., Blom, A., Orrú, C., Viparelli, E. (2013). Laboratory experiment of a mixed sediment Gilbert delta under varying base level. In G. Coco, B. Blanco, M. Olabarrieta, R. Tinoco (Eds.), Symposium on river, coastal and estuarine morphodynamics (pp. 114-114).
5. Chavarrías, V., Blom, A., Orrú, C., Viparelli, E., Martin-Vide, J.P. (2013). Streamwise variation in stratigraphy in a laboratory Gilbert delta in response to a varying base level. In A Crosato (Ed.), Book of abstracts NCR-Days 2013 Vol. 2013. NCR-Publicatie, (ISSN 1568-234X) (pp. 3-5-3-6). Delft: Nederlands Centrum voor Rivierkunde / UNESCO -IHE.

A STUDY ON WAVE-INDUCED RESPONSES OF MOORED FLOATING BODIES EMBEDDED IN A LARGE SCALE WAVE MODEL

PROJECT AIM

An accurate prediction of the response of a vessel, moored in a harbor or coastal region, to the local wave climate (a composite of short and infragravity waves) is of great importance for safe operations of the vessel (e.g. loading and offloading activities). The overall aim of this study is to develop a numerical model system that resolves the wave propagation from deep to shallow water, and that is capable of predicting the (infragravity) wave-induced loads and motions of a vessel moored in a harbor or coastal region. For this purpose a floating body will be schematized in SWASH, a phase resolving numerical wave-flow model recently developed at the TU Delft.

PROGRESS

As infragravity waves play a key role in the wave-induced response of moored vessels, the capabilities of SWASH in reproducing the nearshore transformation of infragravity waves under laboratory and field conditions have been assessed. In the past year model predictions have been compared to laboratory measurements and at present effort is made to assess the model capabilities in reproducing the infragravity wave conditions at a field site (Egmond aan Zee, the Netherlands). Furthermore, a non-moving body has been implemented in SWASH and the extended model was found to be capable of simulating the wave transformation around the non-moving body, including wave transmissions and reflections. At present effort is made to assess the capabilities of the extended model in predicting the wave-induced loads on a fixed vessel, and to extend the model by including motions of a moored vessel.

DISSERTATIONS

-

SCIENTIFIC PUBLICATIONS

1. Rijnsdorp, D.P., Zijlema, M., 2013. Numerical modelling of interactions between non-hydrostatic free-surface flows and a non-moving floating body. Proceedings of the IAHR world congress.
2. van Vledder, G.P., Ruessink, B.G., Rijnsdorp, D.P., 2013. Individual wave height distributions in the coastal zone: Measurements and simulations and the effect of directional spreading. Proceedings of the International Conference on Coastal Dynamics.

PROJECT LEADERS

GS Stelling, M Zijlema

RESEARCH THEME

Mathematical and computational methods for fluid flow analysis

PARTICIPANTS

DP Rijnsdorp

COOPERATIONS

Sichuan University, Chengdu, China

FUNDED

| | |
|--------------|-------|
| NWO | |
| University | - |
| FOM | - |
| STW | - |
| NWO Other | 100 % |
| Industry | - |
| TNO | - |
| GTI | - |
| EU | - |
| Scholarships | - |

START OF THE PROJECT

2011

INFORMATION

DP Rijnsdorp

d.p.rijnsdorp-1@tudelft.nl

PROJECT LEADERS

GS Stelling, JD Pietrzak

RESEARCH THEME

Mathematical and computational methods for fluid flow analysis

PARTICIPANTS

O Kleptsova, JD Pietrzak,
GS Stelling

COOPERATIONS

-

FUNDED

| | |
|--------------|-------|
| TU Delft | |
| University | 100 % |
| FOM | - |
| STW | - |
| NWO Other | - |
| Industry | - |
| TNO | - |
| GTI | - |
| EU | - |
| Scholarships | - |

START OF THE PROJECT

2005

INFORMATION

O Kleptsova
O.Kleptsova@TUDelft.nl

PROJECT AIM

The project aims to develop a new coastal model based on unstructured grids. The model is to be suitable for the investigation of flow phenomena, such as the development and behavior of river plums and associated transport processes in the Dutch and other coastal zones. New discretization of the shallow water equations are being developed and deeper insight gained into the numerical properties and modeling capabilities of this new class of models.

PROGRESS

The project has ended and resulted in a dissertation which was successfully defended.

DISSERTATIONS

1. Kleptsova, O. (2013) Unstructured Orthogonal Meshes for Modeling Coastal and Ocean Flows. PhD-thesis Delft University of Technology

SCIENTIFIC PUBLICATIONS

-

PROJECT AIM

Present state of the art wave models are still insufficiently accurate regarding shallow water dissipation and non-linear interactions in the coastal zone. This project will focus on three main areas; improvement of modelling capabilities of physical processes in the coastal zone, procurement, utilisation and dissemination of high quality datasets and the development, testing and dissemination of new source terms for third generation wave models.

PROGRESS

A new source term formulation for depth-induced wave breaking has been developed, calibrated and verified over an extensive selection of laboratory and field cases. It consists of a joint scaling for wave dissipation dependent on both local slope and normalised wave number and a modification for depth-induced dissipation models to include the effects of wave directionality. These suggestions provide better agreement with observations over a wider range of bathymetries and wave conditions. An inconsistency in the implementation of the LTA source term for triads has also been addressed and alternatives for the LTA considered i.e. an energy conservative DCTA model and the SPB model of Becq et al. (1998). Qualitatively, these models provide superior results at the high frequency end of the spectrum. Analysis of spectral evolution is being carried out by USACE and Shell IEP.

DISSERTATIONS

-

SCIENTIFIC PUBLICATIONS

-

PROJECT LEADERS

G van Vledder, J Hanson,
LH Holthuijsen, K Ewans

RESEARCH THEME

Mathematical and computational
methods for fluid flow analysis

PARTICIPANTS

D Hurdle, M Zijlema, M Christou,
K Hathaway, J Salmon

COOPERATIONS

Arcadis NL/Alkyon Hydraulic
Consultancy & Research, US
Army Corps of Engineers, Shell
International Exploration and
Production

FUNDED

| | |
|-------------------------------|-------|
| Office of Naval Research, USA | |
| University | - |
| FOM | - |
| STW | - |
| NWO Other | - |
| Industry | 100 % |
| TNO | - |
| GTI | - |
| EU | - |
| Scholarships | - |

START OF THE PROJECT

2010

INFORMATION

G Ph van Vledder
015 278 3255
g.p.vanvledder@tudelft.nl

PROJECT LEADERS

A Blom

RESEARCH THEME

Mathematical and computational methods for fluid flow analysis

PARTICIPANTS

G Stecca

COOPERATIONS

A Siviglia (ETH Zurich, Switzerland)

FUNDED

NWO

University -

FOM -

STW -

NWO Other 100 %

Industry -

TNO -

GTI -

EU -

Scholarships -

START OF THE PROJECT

2012

INFORMATION

G Stecca

06 219 84189

G. Stecca@tudelft.nl

<http://www.citg.tudelft.nl/over-faculteit/afdelingen/hydraulic-engineering/sections/environmental-fluidmechanics/staff/blom-a/>

PROJECT AIM

The aim of the project is to improve the mathematical and numerical description of the morphodynamics of rivers characterised by mixed sediment, by developing a mathematical/numerical modeling framework able to treat in a simple, layer-based manner the complex processes taking place on dune-dominated rivers. The final goal is to quantitatively study sediment nourishment to prevent bed degradation in rivers.

PROGRESS

The year 2013 has been mainly devoted to the analysis and implementation of the one-layer Hirano model, as a starting point for the two-layer model. The analysis has resulted into a paper, which is currently submitted for publication to Water Resources Research, and in a number of conference presentations. For a talk on this topic at the NCR days (UNESCO-IHE, Delft, November 2013) G. Stecca has been awarded of the first prize for the best presentation according to a vote by the audience.

DISSERTATIONS

-

SCIENTIFIC PUBLICATIONS

-

SIMULATING WAVES TILL SHORE (SWASH)

PROJECT AIM

The long term goal is the development of the SWASH (Simulating Waves till Shore) model for describing complex changes to rapidly varied flows and wave transformations in coastal waters, ports and harbors.

PROGRESS

The following features have been implemented in SWASH: Wave damping induced by aquatic vegetation (mangroves, salt marshes, etc.) at variable depths is included as an option. In addition to the vertical variation, the possibility of horizontal variation of the vegetation characteristics is included as well. This inclusion enables the vegetation in a given region to be varied so as to reflect real density variations in the field. A number of transport equations is added. Specifically, the user has the option to include the equations for conservative transport of salinity, heat and/or suspended sediment. This enables the user to simulate small-scale density driven flows (e.g. unstable stratified flows, turbidity flows, internal waves) in coastal seas, estuaries, lakes, and rivers. SWASH can be downloaded from <http://swash.sf.net>. There were about 1,500 downloads by the end of 2013 since the launch of SWASH at the website (as of February 9, 2011).

DISSERTATIONS

-

SCIENTIFIC PUBLICATIONS

1. Smit, P., Zijlema, M., and Stelling, G. (2013). Depth-induced wave breaking in a non-hydrostatic, near-shore wave model, *Coast. Engng.*, 76, 1-16.
2. Gerbrant Ph. van Vledder, Gerben Ruessink and Dirk P. Rijnsdorp (2013). Individual wave height distributions in the coastal zone: measurements and simulations and the effect of directional spreading. *Coastal Dynamics 2013*, 7th Int. Conf. on Coast. Dyn., 24-28 June 2013, Arcachon, France.

PROJECT LEADERS

M Zijlema, G Stelling

RESEARCH THEME

Mathematical and computational methods for fluid flow analysis

PARTICIPANTS

PB Smit, DP Rijnsdorp, G van Vledder

COOPERATIONS

-

FUNDED

| | |
|--------------|-------|
| TUD | |
| University | 100 % |
| FOM | - |
| STW | - |
| NWO Other | - |
| Industry | - |
| TNO | - |
| GTI | - |
| EU | - |
| Scholarships | - |

START OF THE PROJECT

2010

INFORMATION

M Zijlema
015 278 3255
m.zijlema@tudelft.nl
<http://swash.sf.net>

DEVELOPMENT OF A QUASI-3D MORPHODYNAMIC MODEL AND ITS APPLICATION TO MEANDER PROCESSES AT HIGH CURVATURE

PROJECT LEADERS

WSJ Uijttewaal, HJ de Vriend

RESEARCH THEME

Mathematical and computational methods for fluid flow analysis

PARTICIPANTS

W Ottevanger, K Blanckaert, CJ Sloff

COOPERATIONS

Deltares (Netherlands), EPFL (Switzerland), IGB (Germany)

FUNDED

| | |
|--------------------|-------|
| STW, NWO, Deltares | |
| University | - |
| FOM | - |
| STW | 100 % |
| NWO Other | - |
| Industry | - |
| TNO | - |
| GTI | - |
| EU | - |
| Scholarships | - |

START OF THE PROJECT

2008

INFORMATION

W Ottevanger
015 278 4069
w.ottevanger@tudelft.nl

PROJECT AIM

Development of a quasi-3D morphodynamic model which is valid for sharply curved river bends, such that high spatial and temporal scales may be simulated. Subsequently, the quasi-3d model will be validated using laboratory and field measurements, as well as more detailed software models (LES, RANS). Finally the model will be used for fundamental research into the processes (momentum redistribution, secondary flow, bank and bed shear stresses) and the dynamics (river bed adaptation, bank erosion and accretion, planform development) of meandering rivers (at high curvature).

PROGRESS

A parameter study using axi-symmetric fully developed Large-eddy simulations was performed and bank shear stresses were related to 1D and quasi-3D model quantities. The bank shear stresses are higher than would be expected based on the depth-averaged velocity alone. Furthermore, for large increasing width-to-depth ratio the bank shear stresses no longer increase, whereas the bed shear stresses do continue to increase. This behavior suggests that sharply curved meander bends tend to deepen, rather than migrate laterally. The dissertation was written and successfully defended.

DISSERTATIONS

1. Ottevanger, W., (2013) Modelling and parameterizing the hydro- and morphodynamics of curved open channels. PhD-thesis Delft University of Technology.

SCIENTIFIC PUBLICATIONS

1. Ottevanger, W., K. Blanckaert, W. S. J. Uijttewaal, and H. J. de Vriend (2013), Meander dynamics: A reduced-order nonlinear model without curvature restrictions for flow and bed morphology, *J. Geophys. Res. Earth Surf.*, 118, 1118-1131, doi:10.1002/jgrf.20080. 011).

HYDRAULIC IMPACT OF OVERTOPPING WAVES ON A MULTIFUNCTIONAL DIKE

PROJECT AIM

Multifunctional dikes can be designed in an infinite number of ways. The most relevant hydraulic issues are related to the impact of waves on various parts of the structure. So the aim of this project is to quantify the hydraulic impact of overtopping wave on residential buildings that are part of a multifunctional flood defence.

PROGRESS

After finishing the literature study, experiments have been performed in the laboratory at Flanders Hydraulics. The experiments comprise the determination of force and pressure distribution on a vertical plane which is subjected to impacting waves. In this way the wave properties can be related to impact forces. Velocities are determined by using video recordings of the entrained bubbles moving with the water.

DISSERTATIONS

-

SCIENTIFIC PUBLICATIONS

1. Xuexue Chen, Wim Uijtewaal, Sebastiaan Jonkman, Toon Verwaest. 2013. "Hydrodynamic load on buildings caused by overtopping wave." 4th International Conference on the Application of Physical Modelling to Port and Coastal Protection (Coastlab 12), Proceedings, 119–126.

PROJECT LEADERS

WSJ Uijtewaal

RESEARCH THEME

Complex dynamics of fluids

PARTICIPANTS

X Chen, B Jonkman

COOPERATIONS

Deltares, STOWA, Flanders

Hydraulic Res., RWS. Waterdienst

FUNDED

STW

University -

FOM -

STW 100 %

NWO Other -

Industry -

TNO -

GTI -

EU -

Scholarships -

START OF THE PROJECT

2011

INFORMATION

X Chen

06 864 49343

X.Chen-2@tudelft.nl

BED AND FORM RESISTANCE IN RIVERS AT HIGH WATER STAGES

PROJECT LEADERS

WSJ Uijttewaai, GS Stelling

RESEARCH THEME

Complex dynamics of fluids

PARTICIPANTS

Shahid Ali

COOPERATIONS

Deltares, RWS

FUNDED

NUFFIC, Rijkswaterstaat

University -

FOM -

STW -

NWO Other -

Industry 10 %

TNO -

GTI -

EU -

Scholarships 90 %

START OF THE PROJECT

2007

INFORMATION

S Ali

015 278 5974

S.Ali@tudelft.nl

PROJECT AIM

In the flood plains of rivers there are many obstacles and landforms, which requires high demand for numerical modeling. Due to the large computational domain and limitation of computer capacity, complete details can generally not be resolved. This study focuses on correct representation of resistance elements in a numerical simulation and consistent behavior towards high water stages. A number of processes related to vegetation, weirs and bed-forms will be studied experimentally in great detail in order to come to an improved implementation of physical processes.

PROGRESS

Experiments to investigate the structure of the flow over the oblique vegetated groynes and other complex phenomena related to it have been performed. A 2-d numerical study of flow over plain weir-like obstacles has been conducted by using RANS mathematical model including free surface variations. A non-linear k- ϵ model has been applied for turbulence closure. The flow conditions under which the undulations occur and the wave characteristics of the undular hydraulic jump caused by the weir-like obstacles have been also investigated. 3-d numerical simulations have been performed for flow over oblique weir-like obstacles to investigate the flow features in the vicinity of the oblique obstacles.

DISSERTATIONS

1. S. Ali, (2013) Flow over weir-like obstacles. PhD-thesis Delft University of Technology.

SCIENTIFIC PUBLICATIONS

1. Ali, S. and Uijttewaai, W. S. J. 2013. Flow resistance of vegetated weir-like obstacles during high water stages. Journal of Hydraulic Engineering, ASCE, Vol. (139), No. (3). pp. 325-330.

THE MORPHODYNAMIC MODELING OF INTERTIDAL AREAS

PROJECT AIM

The objective of the project is to improve the morphodynamic modelling of intertidal areas, focusing on model improvement and better model usage. Morphodynamic and hydrodynamic processes are strongly coupled and cover a wide range of time and length scales. Therefore, a multiple-scale approach is required. Typical challenges in model improvement are dealing with the wetting and drying of shallow areas, the coupling between hydrodynamics and morphodynamics on the different length and time scales and the lack of accuracy of coarse and efficient models.

PROGRESS

The subgrid method of Casulli, 2009 uses small scale bathymetry information for simulations on a coarser grid. Based on a similar approach, a depth-averaged shallow water model is derived, that accounts for small scale bathymetry and roughness variations. The hydrodynamic results show a significant increase in accuracy, with only a slight increase in computation cost. We introduced a multiple grid approach to compute morphodynamics. The subgrid-based hydrodynamic model is coupled to a high resolution morphodynamic model. This gives a strong increase in accuracy of the morphodynamic solution. In addition, a method is being developed to take small scale effect into account to determine the sediment concentration and the net erosion and deposition.

DISSERTATIONS

-

SCIENTIFIC PUBLICATIONS

1. Volp, N. D., B. C. van Prooijen, and G. S. Stelling (2013), A finite volume approach for shallow water flow accounting for high-resolution bathymetry and roughness data, *Water Resour. Res.*, 49,4126–4135, doi:10.1002/wrcr.20324.

PROJECT LEADERS

GS Stelling, JD Pietrzak, BC van Prooijen

RESEARCH THEME

Mathematical and computational methods for fluid flow analysis

PARTICIPANTS

ND Volp

COOPERATIONS

Deltares, Rijkswaterstaat, BAW, Bundeswehr Universität München

FUNDED

Building with Nature, Ecoshape

University -

FOM -

STW -

NWO Other -

Industry 100 %

TNO -

GTI -

EU -

Scholarships -

START OF THE PROJECT

2009

INFORMATION

ND Volp

015 278 4069

n.d.volp@tudelft.nl

A SPECTRAL SHALLOW-WATER WAVE MODEL WITH NONLINEAR ENERGY- AND PHASE EVOLUTION

PROJECT LEADERS

LH Holthuijsen

RESEARCH THEME

Mathematical and computational methods for fluid flow analysis

PARTICIPANTS

GS Stelling, LH Holthuijsen,
M Zijlema, TT Janssen, PB Smit

COOPERATIONS

University of Notre Dame

FUNDED

| | |
|--------------------------|-------|
| Office of Naval Research | |
| University | - |
| FOM | - |
| STW | - |
| NWO Other | - |
| Industry | 100 % |
| TNO | - |
| GTI | - |
| EU | - |
| Scholarships | - |

START OF THE PROJECT

2006

INFORMATION

PB Smit
015 278 2902
P.B.Smit@tudelft.nl

PROJECT AIM

The project aim is to develop a conceptual extension of spectral energy wave models to be able to capture spatial inhomogeneity in the wave field (due to diffraction, refraction) and to improve present formulations for the triad wave-wave interactions. Furthermore, to allow for an extreme flexibility in spatial resolution, the present spectral wave model SWAN is implemented on an unstructured computational grid (SWANus). The first application of such a grid is, in cooperation with Notre Dame, a coupling with the ocean circulation model ADCIRC to improve the hurricane prediction capability for New Orleans.

PROGRESS

Based upon a formal multiple scales analysis, we have derived an approximate transport equation for the evolution of the second order wave statistics over variable topography. The derived model, as is demonstrated by comparison to observations, includes effects such as coherent interference and diffraction. Conceptually, the model is formulated in terms of the Wigner-Ville spectrum which is akin, and for quasi-homogeneous conditions reduces to, the variance density spectrum used in modern stochastic wave models. As such, the model is a natural extension of existing third-generation wave models to include effects such as diffraction and coherent interference induced by the topography. Previously the spectral energy wave model SWAN was made applicable for unstructured grids and the code has been released to the public domain.

DISSERTATIONS

-

SCIENTIFIC PUBLICATIONS

1. Smit, P.B, M. Zijlema, and G.S.S. Stelling. "Depth-induced wave breaking in a non-hydrostatic, near-shore wave model." *Coastal Engineering* 76 (2013): 1-16.
2. Smit, P. B., and T. T. Janssen. "The Evolution of Inhomogeneous Wave Statistics through a Variable Medium." *Journal of Physical Oceanography* 43.8 (2013).

GEOSCIENCE & REMOTE SENSING



Prof.dr.ir. H Jonker



Prof.dr.ir. AP Siebesma

This group studies an entirely new research field using existing expertise in fluid mechanics and turbulence at TU Delft to address important questions in the field of weather and climate. Special attention is paid to the role of clouds, of which relatively little is known. It is believed that clouds could have a considerable impact on the size of the estimated enhanced greenhouse effect.

HIGH RESOLUTION MODELING OF DEEP CUMULUS CONVECTION

PROJECT AIM

A realistic representation of deep cumulus clouds remains one of the most challenging problems in atmospheric modeling. Numerical Weather Prediction and climate models, in which deep convection is parametrized, tend to predict the onset of deep convection too early during the day. We will investigate the transition from shallow clouds to deep convection using the Dutch Atmospheric Large Eddy Simulation (DALES) model. The simulation results of DALES will be used to determine the relative roles of gradual moistening of the cloud layer and the organization of the boundary layer below cloud base.

PROGRESS

Project has been finished. The thesis, entitled "The interaction between deep convective clouds and their environment" has been defended successfully on January 2014.

DISSERTATIONS

-

SCIENTIFIC PUBLICATIONS

1. Dorrestijn, J. Crommelin, D.T., Biello, J., Boing, S. 2013 A data-driven stochastic multi-cloud model for stochastic parameterization of deep convection. Phil. Trans. R. Soc. A., 371, 20120 374.

PROJECT LEADERS

HJJ Jonker, AP Siebesma

RESEARCH THEME

Complex dynamics of fluids

PARTICIPANTS

SJ Böing, HJJ Jonker, AP Siebesma,
SR de Roode

COOPERATIONS

KNMI, Dr. W.Grabowski (NCAR,
Boulder, Colorado, U.S.A)

FUNDED

| | |
|--------------|-------|
| TU Delft | |
| University | 100 % |
| FOM | - |
| STW | - |
| NWO Other | - |
| Industry | - |
| TNO | - |
| GTI | - |
| EU | - |
| Scholarships | - |

START OF THE PROJECT

2009

INFORMATION

S Böing
015 278 3478
s.j.boing@tudelft.nl
www.grs.citg.tudelft.nl

CLOUD-CLIMATE FEEDBACK: THE ROLE OF BOUNDARY LAYER CLOUDS

PROJECT LEADERS

SR de Roode, HJJ Jonker,
AP Siebesma

RESEARCH THEME

Complex dynamics of fluids

PARTICIPANTS

J van der Dussen, SR de Roode,
HJJ Jonker, AP Siebesma

COOPERATIONS

KNMI, + 12 other EU partners
involved in EUCLIPSE

FUNDED

| | |
|--------------|-------|
| EU | |
| University | - |
| FOM | - |
| STW | - |
| NWO Other | - |
| Industry | - |
| TNO | - |
| GTI | - |
| EU | 100 % |
| Scholarships | - |

START OF THE PROJECT

2010

INFORMATION

J van der Dussen
015 278 4720
J.J.vanderDussen@tudelft.nl
www.grs.citg.tudelft.nl

PROJECT AIM

The cloud response due to the enhanced greenhouse effect remains the largest source of uncertainty in climate model projections of a future climate. The EU-funded Cloud Intercomparison, Process Study & Evaluation Project (EUCLIPSE) aims to reduce the uncertainty in the representation of cloud processes and feedbacks in the new generation of Earth System Models (ESMs). This sub-project will use the Dutch Atmospheric Large-Eddy Simulation model to study in detail turbulent flows in cloudy atmospheres. Central question is how the vertical atmospheric stability controls the spatial coverage and depth of low clouds like stratocumulus and shallow cumulus.

PROGRESS

A large-eddy-simulation model intercomparison study of a Lagrangian transition of a marine stratocumulus cloud layer was performed. Six modeling groups participated and the article containing the results has been published. To better understand the role of various physical processes on the evolution of a solid cloud deck a budget equation for the vertically integrated liquid water content has been derived. Using this equation, a criterion can be analytically derived, beyond which stratocumulus clouds start to thin. The article describing these results has recently been published (January 2014). We participate in an international intercomparison study that aims at determining the sign of the cloud-climate feedback. Some model development was required to make the simulations run properly.

DISSERTATIONS

-

SCIENTIFIC PUBLICATIONS

1. Van der Dussen, J. J.; de Roode, S. R.; Ackerman, A. S.; Blossey, P. N.; Bretherton, C. S.; Kurowski, M. J.; Lock, A. P.; Neggers, R. A. J.; Sandu, I. & Siebesma, A. P. The GASS/EUCLIPSE model intercomparison of the stratocumulus transition as observed during ASTEX: LES results J. Adv. Model. Earth Syst., 2013, 5, 483-499.

DROPLET-TURBULENCE DYNAMICS UNDER HETEROGENEOUS CONDITIONS

PROJECT AIM

The focus will be on the evolution of droplet size distributions under a sharp gradient in the mean gas velocity, the droplet concentration and the background humidity. The goal of this project is to understand the interplay between the turbulence dynamics, and the droplet distribution. The two key questions to be addressed are: What is the influence of shear in the mixing layer on the droplet distribution and dispersion, droplet collisions and coalescence efficiency. How are the dispersion, collision frequency and coalescence efficiency influenced by the orientation of the mixing layer with respect to gravity?

PROGRESS

Last year we have spent a substantial amount of time on the rebuttal of the first paper. Some disagreements with one of the reviewers oblige us to rewrite our second order discretization DNS code for isotropic turbulence to a pseudospectral code. Fortunately, the paper has now been accepted. The new code will be used for future research. We also continued developing our simple model to compute the effect of the eigenvalues of the flow on the collision chances. We were able to use the PDFs of dissipation and vorticity of the flow obtained from the DNS and feed it to the atoms model. Collisions statistics for the dissipation are in good agreement, at a fraction of the computational cost. Results are written in a paper. We also started investigating the role of gravity on collision statistics.

DISSERTATIONS

-

SCIENTIFIC PUBLICATIONS

-

PROJECT LEADERS

HJJ Jonker

RESEARCH THEME

Complex dynamics of fluids

PARTICIPANTS

V Perrin, HJJ Jonker

COOPERATIONS

Prof W. vd Water (TUE)

Humberto Bocanegra Evans (TUE)

FUNDED

FOM

University -

FOM 100 %

STW -

NWO Other -

Industry -

TNO -

GTI -

EU -

Scholarships -

START OF THE PROJECT

2010

INFORMATION

V Perrin

015 278 9174

v.e.perrin@tudelft.nl

www.grs.cityg.tudelft.nl

PREDICTIVE LARGE-EDDY-SIMULATIONS: IMPROVING CLOUD AND PRECIPITATION FORECASTING

PROJECT LEADERS

HJJ Jonker, AP Siebesma

RESEARCH THEME

Complex dynamics of fluids

PARTICIPANTS

J Schalkwijk, HJJ Jonker,
AP Siebesma, RAJ Neggers

COOPERATIONS

KNMI

FUNDED

TUD/KNMI

University 50 %

FOM -

STW -

NWO Other -

Industry 50 %

TNO -

GTI -

EU -

Scholarships -

START OF THE PROJECT

2010

INFORMATION

J Schalkwijk

015 278 9174

J.Schalkwijk@tudelft.nl

www.grs.citg.tudelft.nl

PROJECT AIM

Current weather and climate models do not have sufficient resolution to explicitly resolve low cloud evolution, and therefore use statistical models for this purpose. While these models are reasonably successful in forecasting statistical estimates of relevant weather properties like precipitation and cloud amount, any local quantitative prediction (where exactly is a cloud developing) is outside their reach. This program aims to improve prediction accuracy by using Large Eddy Simulations (LES) to perform the needed high-resolution calculations and integrate this in large-scale prediction models to create a multi-scale model hierarchy. Excessive computational requirements always forced reasonable domain LES to run on supercomputing facilities, whose batch queuing protocols inhibit interaction. This program aims to solve this using Graphical Processing Units (GPUs) to provide the necessary computational power.

PROGRESS

State-of-the-art simulations have been performed in this 'forecasting mode', some covering a large domain (the Netherlands) and others covering a large time frame (a full year). This provides a unique dataset to evaluate the performance of LES in simulating real-weather situations. The dataset provides extensive validation and comparison possibilities with available observations from the CESAR observatory and other models from the KNMI Testbed. The dataset was validated with respect to RACMO and with respect to Cabauw observations. A second full year-simulation was initiated to provide a high-resolution, but small domain, 'zoom' of the original simulation. We are currently performing a study of the time and length scales statistically dominant to turbulent transport in 'realistic' weather, i.e. including cumulus/stratocumulus convection, fronts, storms, etc.

DISSERTATIONS

-

SCIENTIFIC PUBLICATIONS

1. Schalkwijk, J., Jonker, H. J. J., & Siebesma, A. P. (2013). "Simple Solutions to Steady-State Cumulus Regimes in the Convective Boundary Layer". *Journal of the Atmospheric Sciences*, 70(11), 3656–3672. doi:10.1175/JAS-D-12-0312.1.

PROJECT AIM

The aim of this project is to simulate climate adaptation in neighbourhoods and districts of cities, with a main emphasis on heat. Issues like temperature effects and surface heat balances for building facades are taken into account. The model is coupled to a meso-scale model for large scale effects of the urban heat island effect.

PROGRESS

This year we implemented a new scatter function for all radiation scattering from a diffuse surface. The old scatter function that was implemented assumed a uniform distribution, which was incorrect. The new scatter function uses the Lambert cosine scatter function. With this new scatter function implemented, we extended the radiation model for computing the mean radiant temperature in an urban environment. With the new scatter function, the mean radiation temperature is validated with theory. Furthermore, we created a simple parameterization for a flat plate. Although this is far from the urban environment, this helps us in understanding the different processes that occur. We also used this simple parameterization for the case set-up for our fully coupled radiation-surface energy balance-CFD model. When performing the first simulations for this set-up, we discovered that the steady state assumption is invalid. Therefore, we have modified the program to run transient simulations.

DISSERTATIONS

-

SCIENTIFIC PUBLICATIONS

-

PROJECTLEADERS

HJJ Jonker, S Kenjeres,
SR de Roode

RESEARCHTHEME

Complex dynamics of fluids

PARTICIPANTS

PJC Schrijvers, S Kenjeres,
SR de Roode, HJJ Jonker

COOPERATIONS

WUR, TNO

FUNDED

| | |
|---------------------|-------|
| Kennis voor Klimaat | |
| University | - |
| FOM | - |
| STW | - |
| NWO Other | - |
| Industry | 100 % |
| TNO | - |
| GTI | - |
| EU | - |
| Scholarships | - |

START OF THE PROJECT

2010

INFORMATION

P Schrijvers
015 278 9174
P.J.C.Schrijvers@tudelft.nl
www.grs.city.tudelft.nl

PROJECT LEADERS

D Crommelin (CWI), AP Siebesma,
HJJ Jonker

RESEARCH THEME

Complex dynamics of fluids

PARTICIPANTS

J Dorrestijn, D Crommelin (CWI),
F Selten (KNMI) AP Siebesma,
HJJ Jonker

COOPERATIONS

CWI, KNMI

FUNDED

| | |
|--------------|-------|
| NWO/ALW | |
| University | - |
| FOM | - |
| STW | - |
| NWO Other | 100 % |
| Industry | - |
| TNO | - |
| GTI | - |
| EU | - |
| Scholarships | - |

START OF THE PROJECT

2010

INFORMATION

HJJ Jonker
015 278 6157
H.J.J.Jonker@tudelft.nl
www.grs.citg.tudelft.nl

PROJECT AIM

Stochastic parameterization is an exciting new topic at the intersection of applied mathematics and climate science. Because of the shortcomings of currently used, deterministic parameterizations and the pivotal role of clouds and convection in climate change uncertainties, stochastic methods for convection parameterization have become a hot research theme in recent years. In this project we will develop a stochastic approach to convection parameterization, combining new mathematical ideas on hybrid stochastic-deterministic models and multiscale systems with results from Large Eddy Simulation (LES) of atmospheric moist convection. The overall goal is to formulate a stochastic parameterization scheme that is suitable for practical use in climate models, and to evaluate the impact of such a scheme on cloud-climate feedbacks.

PROGRESS

At this moment we are writing a paper about the usage of radar-data from Darwin in Australia, to construct a similar stochastic parameterization of deep convection. This paper is almost ready for submitting, we plan to submit this month to the Journal of Atmospheric Science. Further, we are testing this parameterization of deep convection in a simplified climate model called SPEEDY. Such a model can be executed at a laptop such that it is easy to test the performance of the new parameterization. We are now examining the results of the implementation in this climate model. The step from implementation in this simplified climate model to implementation in a state-of-the-art climate model is small.

DISSERTATIONS

-

SCIENTIFIC PUBLICATIONS

1. Dorrestijn, J. Crommelin, D.T., Biello, J., Boing, S. 2013 A data-driven stochastic multi-cloud model for stochastic parameterization of deep convection. Phil. Trans. R. Soc. A., 371, 20120 374.

LOCAL PRECIPITATION EXTREMES DERIVED FROM NON-HYDROSTATIC MODELING

PROJECT AIM

Events of extreme precipitation have a huge influence on society. They are associated with flooding, erosion, and water damage and may impact transport and safety. It is commonly expected that precipitation extremes will increase as the climate warms, as a warmer atmosphere has a larger capacity for moisture. With this study, we aim to increase the understanding of underlying causes of extreme precipitation, as well as anticipate how events of extreme precipitation will react to a warming climate. To this end, observational data, as well as Large Eddy Simulations (LES) are used. Furthermore, we will explore local precipitation extremes over the Netherlands within HARMONIE, a non-hydrostatic high resolution model.

PROGRESS

Using KNMI precipitation data, the dependence of extreme precipitation to temperature and humidity has been analyzed. These results have been further assessed using a conceptual 1D model. This work is presented in "Understanding convective extreme precipitation scaling using observations and an updraft model", which has been published in the Journal of Atmospheric Sciences. We are currently in the process of using hindcasts to better understand the large scale forcings associated with extreme events. These results will be used in LES to further develop our understanding of earlier findings.

DISSERTATIONS

-

SCIENTIFIC PUBLICATIONS

1. Loriaux, Jessica M., Geert Lenderink, Stephan R. De Roode, A. Pier Siebesma, 2013: Understanding Convective Extreme Precipitation Scaling Using Observations and an Entraining Plume Model. *J. Atmos. Sci.*, 70, 3641-3655.

PROJECT LEADERS

AP Siebesma

RESEARCH THEME

Complex dynamics of fluids

PARTICIPANTS

J Loriaux, AP Siebesma,
G Lenderink, SR de Roode

COOPERATIONS

KNMI

FUNDED

| | |
|----------------------------------|-------|
| Knowledge for Climate University | - |
| FOM | - |
| STW | - |
| NWO Other | - |
| Industry | 100 % |
| TNO | - |
| GTI | - |
| EU | - |
| Scholarships | - |

START OF THE PROJECT 2011

INFORMATION

J Loriaux

030 220 6376

j.m.loriaux@tudelft.nl

www.grs.citg.tudelft.nl



Prof.dr.ir. AA Darhuber



Prof.dr.ir. MEH van Dongen (em)

In 2006 prof. M.E.H. (Rini) van Dongen retired as head of the research group Gas Dynamics and obtained emeritus status. In 2007 prof. Anton Darhuber was appointed as his successor. Prof. A. (Mico) Hirschberg was interim leader of the group Gas Dynamics in 2006 and 2007. On January 1, 2008 the research group Gas Dynamics was officially renamed into Mesoscopic Transport Phenomena (MTP). On January 1, 2009 the head of the group Low-Temperature Physics (LTE) prof. A.T.A.M. (Fons) de Waele retired and LTE became a part of MTP. Therefore, currently three major lines of research coexist in MTP: the first corresponds to the activities of the former group Gas Dynamics, i.e. research on aero-acoustics and condensation phenomena; the second involves fluid dynamics at small lengthscales, where interfacial typically dominate over inertial effects. The third corresponds to the activities of the former group Low-Temperature Physics, i.e. research on thermo-acoustics.

In September 2008, prof. Federico Toschi was appointed professor in the Department of Applied Physics and became a member of MTP. He is working in the field of statistical physics, fluid dynamical turbulence and micro-/nanofluidics. In February 2009, Jens Harting was appointed Assistant Professor in the group MTP. His expertise rests with large-scale Lattice Boltzmann simulations of suspension dynamics as well as micro- and meso-scale flows.

The research activities related to gas dynamics concern the study of wave phenomena in gases. Aero-acoustics is the study of the interaction between sound and flows. The research concerns the study of wave generation by elementary processes in flows, with the focus on confined flows and sound generation by vortices. This work has many important industrial applications. Condensation phenomena are studied using gas-dynamical devices such as expansion wave tubes to obtain fundamental information about the physics of nucleation and droplet growth in complex gas mixtures. This involves the development of models for the properties of molecular clusters in the nanometer range at extreme conditions far below the freezing point, for which bulk liquid properties are unknown.

Research in the area of micro- and nano-fluidics comprises both fundamental and application-inspired topics ranging from fluid physics at nano-scales to manufacturing processes of optoelectronic devices. Current and commencing projects concern dip- and die-coating of chemically patterned substrates, flows driven by temperature and concentration gradients, as well as flows involving phase changes.

Research activities of the former group LTE concern pulse-tube refrigeration, thermoacoustics, and vortex cooling. These topics have a common thermodynamic and hydrodynamic background. They provide cooling without moving parts in the cold regions of the system. All topics address new physical questions in gas dynamics with the aim of unraveling basic working principles.

DIAGNOSTICS OF VOICE AND RESPIRATION PATHOLOGIES

PROJECT AIM

Using in-vitro experiments we study the effects of the interaction between air flow and oscillations of flexible walls at conditions relevant for speech and cough. Goal is the development of physical models, which can support diagnostics of pathologies by means of signal analysis. Similar methods are used for sound synthesis by physical modeling, applied to human voice and woodwind musical instruments.

PROGRESS

The impact of Coanda effect on vocal fold oscillation has been studied. A review paper has been written. New collaborations has been established.

DISSERTATIONS

-

SCIENTIFIC PUBLICATIONS

-

PROJECTLEADERS

AA Darhuber

RESEARCHTHEME

Complex dynamics of fluids

PARTICIPANTS

A Hirschberg, J Haas, X Pelorson,
B Fabre, J Gilbert

COOPERATIONS

Universite de Grenoble (Fr), LAUM
(Universite du Maine, FR), UMPC
(Fr), LIMSI (Fr)

FUNDED

| | |
|--------------|-------|
| University | 100 % |
| FOM | - |
| STW | - |
| NWO Other | - |
| Industry | - |
| TNO | - |
| GTI | - |
| EU | - |
| Scholarships | - |

START OF THE PROJECT

2002

INFORMATION

A Hirschberg

040 2547 21 63

A.Hirschberg@tue.nl

FLOW-INDUCED PULSATIONS IN GAS TRANSPORT SYSTEMS: PREDICTION, PREVENTION AND INFLUENCE ON VOLUME FLOW MEASUREMENTS

PROJECT LEADERS

AA Darhuber

RESEARCH THEME

Complex dynamics of fluids

PARTICIPANTS

A Hirschberg, G Nakiboglu,

O Rudenko, HWM Hoeijmakers
(Utwente), SPC Belfroid (TNO), J
Golliard (TNO)

COOPERATIONS

DNV-Kema, TNO, ASML, Shell, UT,
VKI, Philips, LMS (Be), EDF (Fr),
LAUM (Universite du Maine, FR),
Flowairs (EC project), Tango (EC
project), Jeronimo (EC project)

FUNDED

| | |
|-----------------|------|
| STW, University | |
| University | 20 % |
| FOM | - |
| STW | 50 % |
| NWO Other | - |
| Industry | - |
| TNO | - |
| GTI | - |
| EU | 30 % |
| Scholarships | - |

START OF THE PROJECT

2002

INFORMATION

A Hirschberg
040 2547 21 63
A.Hirschberg@tue.nl

PROJECT AIM

The quantitative prediction of unsteady shedding of vortices in confined flows and the interaction of these vortices with acoustic waves. Prediction of self-sustained flow-instabilities in high-pressure gas transport systems and impact of such instabilities on volume-flow measurements. The focus of the project is presently on fundamental aspects of the design of mufflers and the whistling of corrugated pipes.

PROGRESS

The whistling of corrugated pipes has been studied. A linear model has been developed to predict the flow conditions at the onset of whistling. The influence of corrugation geometry has been studied. A silent corrugation geometry has been designed which uses alternating corrugation geometries. The two successive cavities are designed to interfere destructively through the acoustic field and the distance between successive cavities is optimized to obtain negative hydrodynamic interference. The results of G. Nakiboglu have been presented at the Ercofac da Vinci competition and awarded a shared first prize. This PhD work of G. Nakiboglu was also awarded the first Hoogedoor price by the KIVI.

DISSERTATIONS

-

SCIENTIFIC PUBLICATIONS

1. O. Rudenko, G. Nakiboglu, A. Holten, A. Hirschberg, "Corrugated pipe segment with anechoic termination: critical Mach number for whistling" Proceedings 19th AIAA/CEAS Aeroacoustics Conference (34th AIAA Aeroacoustics Conference), Berlin, Germany, 27-29 May 2013.
2. G. Nakiboglu, O. Rudenko, A. Hirschberg, "Hydrodynamic interference in corrugated pipe whistling", Proceedings ICSV 20, Bangkok, Thailand, 7-13 July 2013.
3. O. Rudenko, D. Mertens, G. Nakiboglu, A. Hirschberg, S. Belfroid, "A linear model for the onset of whistling in corrugated pipe segments: influence of the geometry", Proceedings Pressure Vessels & Piping Division Conference ASME, PVP29013, Paper No PVP2013-97273, 14-18 July 2013, Paris.
4. O. Rudenko, G. Nakiboglu, A. Hirschberg, "On whistling of pipes with a corrugated segment: Experiment and theory", Journal of Sound and Vibration 332, 7226 (2013). DOI: 10.1016/j.jsv.2013.08.034.
5. O. Rudenko, G. Nakiboglu, A. Hirschberg, "Onset of Flow Induced Tonal Noise in Corrugated Pipe Segments", J. Pressure Vessel Technol. (), (Jan 01, 2014)doi:10.1115/1.4026595.
6. D. Tonon, E. Moers, A. Hirschberg, "Quasi-steady acoustic response of wall perforations subject to a grazing-bias flow combination", J. Sound Vib. 332 (2013) 1654-1673.

DENSE SUSPENSIONS IN MEDICINE AND INDUSTRY

PROJECT AIM

Colloidal particles are commonly used as stabilizers for fluid-fluid interfaces. In this project a system of colloidal particles suspended in two immiscible fluids (water and oil) is being considered. The lattice Boltzmann method is used to simulate the two fluids, while the suspended particles are simulated by molecular dynamics. A particular focus of this PhD project is on anisotropic particles such as rods, cylinders, platelets and ellipsoids, where the role of capillary and electrostatic particle-particle interactions shall be investigated.

PROGRESS

The effect of the particle anisotropy on some properties of the emulsions are studied. The difference of prolate and oblate ellipsoids was explored to see the effect of the different degrees of freedom. To get a further understanding the studies at model systems (such as one or many particles at a flat or spherical interface) are continued.

DISSERTATIONS

-

SCIENTIFIC PUBLICATIONS

1. Timescales of emulsion formation caused by anisotropic particles. F. Günther, S. Frijters, J. Harting. Submitted for publication (2013)

PROJECTLEADERS

J Harting

RESEARCHTHEME

Complex dynamics of fluids

PARTICIPANTS

F Günther

COOPERATIONS

-

FUNDED

STW

University -

FOM -

STW 100 %

NWO Other -

Industry -

TNO -

GTI -

EU -

Scholarships -

START OF THE PROJECT

2010

INFORMATION

J Harting

040 247 3766

jharting@tue.nl

SIMULATION OF FERROMAGNETIC PARTICLES BY LATTICE BOLTZMANN METHOD AND MOLECULAR DYNAMICS

PROJECTLEADERS

J Harting

RESEARCHTHEME

Complex dynamics of fluids

PARTICIPANTS

Q Xie

COOPERATIONS

-

FUNDED

STW

University -

FOM -

STW 100 %

NWO Other -

Industry -

TNO -

GTI -

EU -

Scholarships -

START OF THE PROJECT

2013

INFORMATION

J Harting

040 247 3766

j.harting@tue.nl

PROJECT AIM

Implementation of magnetic interaction and external magnetic field in our lb3d code. Investigation of the properties of magnetocapillary swimmer at the interface.

PROGRESS

Magnetic interaction and external magnetic fields have been employed. Benchmark of magnetic particles in a single fluid is verified. Self-assembly of magnetic particles to a snake at a fluid-fluid interface is reproduced. Magnetocapillary swimmer swims well under specific initial conditions in the simulation.

DISSERTATIONS

-

SCIENTIFIC PUBLICATIONS

-

LATTICE BOLTZMANN SIMULATIONS OF MULTIPHASE FLOWS IN MICROFLUIDICS

PROJECT AIM

Development and application of the software LB3D for problems of fluid flows of multiple phases as well as multiple components in confined, complex geometries. Research focuses on a better understanding of models for non-ideal and complex fluid mixtures and the implementation and improvement of boundary conditions to enable more realistic simulations of contact line dynamics.

PROGRESS

Simulations of dilute mixtures. Simulations of superhydrophobic systems. Simulations of multiphase flows in porous media. Preliminary Simulations of electroosmotic slip flow. Supporting Work on publications. Writing work on thesis.

DISSERTATIONS

-

SCIENTIFIC PUBLICATIONS

1. Multi Relaxation Time Lattice Boltzmann Simulations of Multiple Component Fluid Flows in Porous Media. S Schmieschek, A Narváez, J Harting. High Performance Computing in Science and Engineering '12, 39-49.
2. Flow past superhydrophobic surfaces with cosine variation in local slip length ES Asmolov, S Schmieschek, J Harting, OI Vinogradova. Physical Review E 87 (2), 023005.

PROJECT LEADERS

J Harting

RESEARCH THEME

Mathematical and computational methods for fluid flow analysis

PARTICIPANTS

S Schmieschek

COOPERATIONS

-

FUNDED

| | |
|------------------------------------|-------|
| Eindhoven University of Technology | |
| University | 100 % |
| FOM | - |
| STW | - |
| NWO Other | - |
| Industry | - |
| TNO | - |
| GTI | - |
| EU | - |
| Scholarships | - |

START OF THE PROJECT

2009

INFORMATION

J Harting

040 247 3766

jharting@tue.nl

DETECTION AND GUIDANCE OF NANOPARTICLES FOR ENHANCED OIL RECOVERY

PROJECT LEADERS

J Harting, S Luding, H Steeb

RESEARCH THEME

Complex structures of fluids

PARTICIPANTS

SCJ Frijters

COOPERATIONS

Shell-FOM IPP

FUNDED

Shell-FOM IPP

| | |
|--------------|------|
| University | - |
| FOM | 50 % |
| STW | - |
| NWO Other | - |
| Industry | 50 % |
| TNO | - |
| GTI | - |
| EU | - |
| Scholarships | - |

START OF THE PROJECT

2010

INFORMATION

J Harting

040 247 3766

jharting@tue.nl

PROJECT AIM

To find out whether ferromagnetic particles can be a suitable alternative to conventional EOR techniques, and whether pulsed electromagnetic fields could be used to drive these particles to preferred regions. To have control over the movement of the particles will be a major advantage of the proposed method.

PROGRESS

We have continued the study of particle-stabilized emulsions, with a focus on inducing a phase transition from a bijel state to a Pickering state or vice versa, using the wettability of the stabilizing particles as a control parameter. Such a transition is useful in view of the large change in rheology that is effected. We have observed the possibility of a transition in either direction, but large hysteresis effects exist. We have also used the emulsions as a basis for the creation of novel self-assembled porous media, in which one of the fluid phases is solidified (e.g. a polymer hardening), or the particles are connected to form walls. Just as the different emulsions show large differences in rheology, the porous media created from them exhibit a wide range of permeabilities (multiple orders of magnitude). The porous media can be tuned by the same control parameters that govern the emulsion phases. Electrostatic effects are currently being considered as well.

DISSERTATIONS

-

SCIENTIFIC PUBLICATIONS

1. Dynamic phase transitions and time dependent structuring effects in particle-stabilized emulsions, S. Frijters, F. Günther, J. Harting. Submitted for publication (2013).
2. Lattice Boltzmann simulations of anisotropic particles at liquid interfaces. F. Günther, F. Janoschek, S. Frijters, J. Harting. Computers and Fluids 80, 184-189 (2013).
3. Timescales of emulsion formation caused by anisotropic particles. F. Günther, S. Frijters, J. Harting. Submitted for publication (2013).

PROJECT AIM

The aim of this project is to study the physics of dewetting of thin liquid layers on partially wetting surfaces. The evaporation of these films causes technological difficulties, as cooling due to the large latent heat of evaporation of water leads to inhomogeneous thermal contractions of substrates. At the focus is the question whether the dewetting and break-up process of the water layer into droplets can be influenced regarding the size distribution and arrangement of the resulting droplets.

PROGRESS

A numerical model for the dynamics of spontaneous and induced break-up of model liquids has been developed. An experimental setup for dry-spot nucleation induced by an air-jet has been built and systematic experiments have been performed. A second setup for temperature-gradient-induced dry-spot nucleation has been designed and built and is currently being used for a systematic study. A third setup for moving airjets has been designed and built. A complete study of the influence of all relevant parameters on the deformation of the thin liquid film and the resulting break-up behavior and residual droplet distributions has been performed.

DISSERTATIONS

1. Christian W. J. Berendsen, Controlled deformation, rupture and dewetting of thin liquid films on partially-wetting substrates (defense date 18 Nov. 2013).

SCIENTIFIC PUBLICATIONS

1. Christian W.J. Berendsen, Jos C.H. Zeegers, Anton A. Darhuber. Deformation and dewetting of thin liquid films induced by moving gas jets. *Journal of Colloid and Interface Science* 407 (2013) 505–515.
2. Christian W. J. Berendsen, Jos C. H. Zeegers, and Anton A. Darhuber. Thinning and Rupture of Liquid Films by Moving Slot Jets. *Langmuir* 2013, 29, 15851–15858.
3. C. W. J. Berendsen, C. J. Kuijpers, J. C. H. Zeegers and A. A. Darhuber. Dielectrophoretic deformation of thin liquid films induced by surface charge patterns on dielectric substrates. *Soft Matter*, 2013, 9, 4900.

PROJECTLEADERS

AA Darhuber

RESEARCHTHEME

Complex dynamics of fluids

PARTICIPANTS

C Berendsen, J Zeegers,
AA Darhuber

COOPERATIONS

ASML

FUNDED

FOM-IPP met ASML en Océ
University -
FOM 50 %
STW -
NWO Other -
Industry 50 %
TNO -
GTI -
EU -
Scholarships -

START OF THE PROJECT

2010

INFORMATION

AA Darhuber
a.a.darhuber@tue.nl

ENERGY AND LIGHT : HOW MICROFLUIDICS CAN MAKE A DIFFERENCE

PROJECT LEADERS

AA Darhuber

RESEARCH THEME

Complex dynamics of fluids

PARTICIPANTS

AA Darhuber, M Hanyak, D Sinz

COOPERATIONS

Shell International Exploration and Production B.V

FUNDED

| | |
|-----------------------------|------|
| STW, TU/e, Shell University | 25 % |
| FOM | - |
| STW | 65 % |
| NWO Other | - |
| Industry | 10 % |
| TNO | - |
| GTI | - |
| EU | - |
| Scholarships | - |

START OF THE PROJECT

2008

INFORMATION

AA Darhuber
a.a.darhuber@tue.nl

PROJECT AIM

Subproject: Surfactant-assisted enhanced oil-recovery : Systematic investigation and modeling of the surfactant induced flows at micro- and nanoscales. Quantification of the spreading dynamics of surfactants on liquid films in various geometries, ranging from simple test cases to natural porous media. Development of strategies how to use surfactants to increase oil recovery rates.

PROGRESS

Using both experiments and numerical simulations, we studied surfactant spreading on thin liquid films deposited on chemically patterned surfaces. On liquid rivulets, upon which a droplet of surfactant is deposited, a rim develops in the rivulet height profile that is moving away from the deposited surfactant droplet. It is located just behind the leading edge of the surfactant, and to good approximation the rim position $x_{rim}(t)$ follows a power law behavior $x_{rim} \sim t^a$, where the spreading exponent a quantifies the displacement efficiency of a given surfactant. Experiments conducted for both soluble and insoluble surfactants spreading along liquid-air interfaces are in quantitative agreement with numerical simulations. A detailed study of spreading along liquid-liquid interfaces has been performed.

DISSERTATIONS

-

SCIENTIFIC PUBLICATIONS

1. David K. N. Sinz, Myroslava Hanyak, and Anton A. Darhuber. Self-Induced Surfactant Transport along Discontinuous Liquid-Liquid Interfaces. J. Phys. Chem. Lett. 2013, 4, 1039–1043.

PROJECT AIM

The investigation and optimization of the hydrodynamics of die-coating to fabricate active layers of organic light emitting diodes (OLEDs) of uniform thickness and composition based on solution-processing. Means to enhance the influence of surface energy patterns at high coating speeds will be explored as well as methods for mitigation and elimination of evaporation-driven material redistribution.

PROGRESS

An experimental system for structured infrared illumination has been developed. A numerical model coupling heat transfer, gas-phase and liquid-phase transport has been developed and simulation results quantitatively agree with experimental results. The dewetting dynamics of thin liquid films on chemically patterned substrates has been studied. Evaporative instabilities have been characterized and a numerical model agrees qualitatively with the measurements.

DISSERTATIONS

-

SCIENTIFIC PUBLICATIONS

1. B. J. Brasjen, H. Gu and A. A. Darhuber. Dewetting of thin liquid films on chemically patterned substrates: front propagation along narrow lyophobic stripes and stripe arrays. *Microfluid Nanofluid* (2013) 14:669–682.

PROJECT LEADERS

AA Darhuber

RESEARCH THEME

Complex dynamics of fluids

PARTICIPANTS

AA Darhuber, BJ Brasjen, JA Vieyra Salas

COOPERATIONS

Holst Centre Eindhoven

FUNDED

| | |
|--------------|------|
| DPI | |
| University | 25 % |
| FOM | - |
| STW | - |
| NWO Other | - |
| Industry | 75 % |
| TNO | - |
| GTI | - |
| EU | - |
| Scholarships | - |

START OF THE PROJECT

2007

INFORMATION

AA Darhuber

a.a.darhuber@tue.nl

PROJECT LEADERS

J Zeegers

RESEARCH THEME

Complex dynamics of fluids

PARTICIPANTS

R Liew, W Michalek, D Saha,

J Zeegers, J Kuerten

COOPERATIONS

-

FUNDED

| | |
|--------------|------|
| University | - |
| FOM | - |
| STW | 80 % |
| NWO Other | - |
| Industry | 20 % |
| TNO | - |
| GTI | - |
| EU | - |
| Scholarships | - |

START OF THE PROJECT

2009

INFORMATION

J Zeegers

040 247 4212

j.c.h.zeegers@tue.nl

PROJECT AIM

Developing a vortex tube swirling flow system to separate condensate out of gas flow.

PROGRESS

In the past two years the phenomenon of temperature separation with vortex tubes has been unraveled via a thorough experimental study which was combined with an analytical model, leading to a good description. This work was published in Phys. Rev. Lett. in 2012 and will be published in a more comprehensive paper in 2013. Detailed velocity and droplet size measurements have been made in the vortex tube using PDPA and Laser Doppler techniques, part of which was recently published in a paper in Experiments in Fluids. This has become possible using the advanced TSI equipment that was purchased in the first year of the project. Since July 2012 ongoing research has demonstrated the first results of separation of water droplets using vortex tubes. This is a first step towards the end goal of the project. Both PhD students obtained their PhD in 2013. Currently the project is run by a postdoc. Focus is on separation of water droplets and condensate removal.

DISSERTATIONS

1. R. Liew, Droplet behaviour and thermal separation in Ranque Hilsch vortex tubes. PhD thesis Eindhoven University of Technology 2013.
2. W. Michalek, Numerical simulation of droplet laden turbulent flow with application to the Ranque Hilsch vortex tube, Eindhoven University of Technology, 2013.

SCIENTIFIC PUBLICATIONS

1. Physics of Fluids (2013) 25, 123302. A hybrid stochastic deconvolution model for LES simulation of particle laden flow. W. Michalek, J.G.M. Kuerten, J.C.H. Zeegers, R. Liew, J. Pozorski, B.J. Geurts.
2. Experiments in Fluids (2013) 54, 1416. 3D Velocimetry and droplet sizing in the Ranque-Hilsch Vortex tube. R. Liew, J.C.H. Zeegers, J.G.M. Kuerten and W.R. Michalek.
3. Nederlands Tijdschrift voor Natuurkunde (2013), jaargang 79, nummer 2. Mysterie van de Ranque-Hilsch-vortexbuis. R. Liew.

TOWARDS GREEN INKS (TGINK)

PROJECT AIM

Waterborne inks are the future in the area of inkjet printing, since the use of organic solvents has to be reduced for environmental reasons. The particles, dissolved in the ink, should agglomerate and stick at a certain depth in the paper. This agglomeration is steered by the liquid concentrations of the ink, which themselves are determined by sorption and evaporation. This project aims to develop a mathematical model that describes the particle penetration into paper in relation to the ink composition.

PROGRESS

Implementation and evaluation of thermal fluctuations into our simulation package. Evaluation of the resulting Brownian motion of particles, coupled to the lattice Boltzmann code. Evaluation of coalescing droplets on a substrate and the resulting self-similarity over time.

DISSERTATIONS

-

SCIENTIFIC PUBLICATIONS

-

PROJECT LEADERS

J Harting, O Adan, H Huinink

RESEARCH THEME

Mathematical and computational methods for fluid flow analysis

PARTICIPANTS

Dennis Hessling

COOPERATIONS

Océ

FUNDED

M2i

University -

FOM -

STW -

NWO Other -

Industry 100 %

TNO -

GTI -

EU -

Scholarships -

START OF THE PROJECT

2012

INFORMATION

J Harting

040 247 3766

jharting@tue.nl



Prof.dr. HJH Clercx



Prof.dr.ir. GJF van Heijst



Prof.dr. F Toschi



Prof.dr.ir. BJ Geurts

The research in this section concerns transport phenomena, in particular as occurring in turbulent flows. An important line of approach is that vortex dynamics, in which elementary processes are studied in rather isolated configurations. Special attention is given to the influence of body forces associated with background rotation and density stratification. Such situations are met in industrial settings and also within the framework of geophysical fluid dynamics. In addition to transport in turbulent flows, the dynamics of granular media and 3D viscous mixing is studied.

The following main lines of research can be distinguished:

1. Spectral and transport properties of 3D turbulence
2. Dispersion in quasi-2D turbulence
3. Atmospheric physics
4. Granular media and viscous mixing

In most of these themes the research approach is a combination of laboratory experiments, numerical simulation, and theoretical modelling.

PROJECT AIM

The objective of this project concerns the quantification of the vertical turbulent transport of phytoplankton by DNS and the associated process of scum formation at the free surface. This part concerns a combined study involving numerical simulations (TU/e) and field observations (Deltares).

PROGRESS

The formation of a cyanobacterial scum is an unresolved subject. Scum refers to the lasting accumulation of cyanobacteria at the surface of lakes or reservoirs. In this study a hypothesis has been put forward that scum formation is due to the irreversible buoyancy status of cyanobacteria colonies. This status is reached because of the formation of oxygen gas bubbles within the mucilage of a colony. The oxygen gas bubbles grow under supersaturated oxygen conditions created after photosynthesis. To support the hypothesis compression experiments were performed. A fresh scum sample was placed in a pressure chamber and subjected to pressure increments. Upon reaching 3 to 4 Bar of pressure the scum sample sank rather than float. At this pressure the bubbles which provided irreversible buoyancy were dissolved. A paper is being prepared with a theoretical explanation and the description of the experiments.

DISSERTATIONS

-

SCIENTIFIC PUBLICATIONS

1. Aparicio Medrano, E., Uittenbogaard, R.E., Dionisio Pires, L.M., Wiel, B.J.H. van de & Clercx, H.J.H. (2013). Coupling hydrodynamics and buoyancy regulation in *Microcystis aeruginosa* for its vertical distribution in lakes. Ecological Modelling, 248, 41-56.

PROJECT LEADERS

HJH Clercx

RESEARCH THEME

Complex dynamics of fluids

PARTICIPANTS

E Aparicio Medrano, BJH van de Wiel, HJH Clercx

COOPERATIONS

M Dionisio & RE Uittenbogaard (Deltares)

FUNDED

| | |
|--------------|-------|
| Deltares | |
| University | - |
| FOM | - |
| STW | - |
| NWO Other | - |
| Industry | - |
| TNO | - |
| GTI | 100 % |
| EU | - |
| Scholarships | - |

START OF THE PROJECT

2009

INFORMATION

HJH Clercx
 040 247 2680
 h.j.h.clercx@tue.nl
 www.fluid.tue.nl

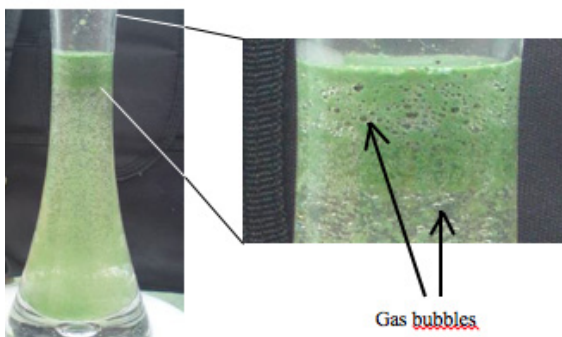

Visible gas bubbles in a *Microcystis* scum collected from the surface of Lake Vlietland (NL) during the summer of 2009.

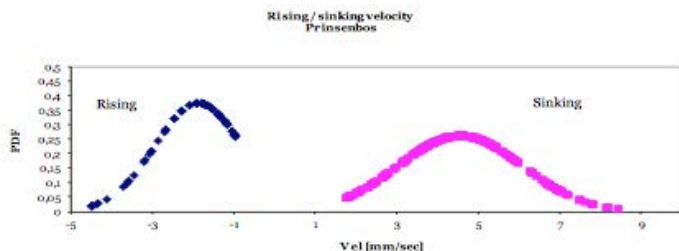

Results of the sample compression experiments leading to buoyancy reversal due to dissolution of gas bubbles. The left side of the figure shows the probability density function (PDF) of the rising velocity of cyanobacterial colonies. The right side shows the PDF of the sinking velocities of cyanobacterial colonies after applying 3 Bar pressure inside the chamber.

LAGRANGIAN MIXING ANALYSIS OF HEAT TRANSFER: A NEW WAY FOR THERMAL OPTIMISATION

PROJECT LEADERS

HJH Clercx

RESEARCH THEME

Complex dynamics of fluids

PARTICIPANTS

O Baskan, HJH Clercx

COOPERATIONS

MFM Speetjens (TU/e-Wbt),

EA Demissie (TU/e-Wbt),

G Metcalfe (CSIRO, Australia)

FUNDED

STW

University -

FOM -

STW 100 %

NWO Other -

Industry -

TNO -

GTI -

EU -

Scholarships -

START OF THE PROJECT

2010

INFORMATION

HJH Clercx

040 247 2680

h.j.h.clercx@tue.nl

www.fluid.tue.nl

PROJECT AIM

The objective is in-depth analysis of the Kenics static mixer by Lagrangian mixing analysis of heat transfer. The study is divided into two subprojects: Topological mixing analysis of heat transfer in the Kenics mixer (E. Demissie; Wbt) and Experimental heat-transfer and mixing analysis of the Kenics mixer (O. Baskan, Applied Phys.). The latter subproject focuses on experimental characterization of Lagrangian mixing properties in case studies by measurement of 3D fluid trajectories and evolution of 3D scalar fields using advanced optical measurement techniques. Benchmarking of numerical thermal mixing analyses and testing of the prototype thermal-analysis tools for advanced data processing.

PROGRESS

An experimental parametric study on the evolution of scalar patterns and coherent flow structures in a simplified Rotated Arc Mixer (RAM) facility is conducted. The results show a strong correlation between scalar patterns and coherent flow structures. The bounded regions in coherent flow structures (islands in the Poincare maps) are indicators of 'unmixedness' (Fig. 1a). In addition, a realistic 3D inline mixer facility is built to investigate the evolution of temperature/concentration fields in the mixer. The facility consists of an optically accessible test section with transparent mixing elements, accommodating a pressure-driven pipe flow. Systematic successive placement of the static mixing elements in the axial flow direction results in a spatially periodic flow field. Preliminary numerical studies have proven the existence of spatially periodic patterns with exponentially decaying intensities (Fig. 1b), which agrees well with the eigenmode analysis of scalar transport in periodic flow fields.

DISSERTATIONS

SCIENTIFIC PUBLICATIONS

- Speetjens, M.F.M. & Clercx, H.J.H. (2013). Formation of coherent structures in a class of realistic 3D unsteady flows. In J. Klapp, A. Medina, A. Cros & C. Vargas (Eds.), Fluid Dynamics in Physics, Engineering and Environmental Applications, Part 1. (pp. 139-157) Springer.

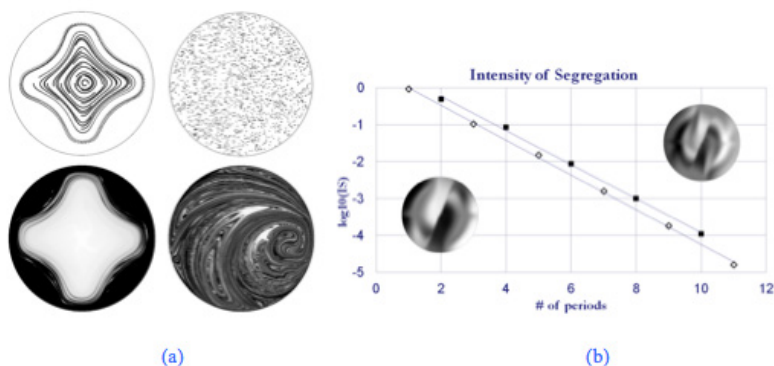

(a) Coherent flow structures (1st row) and scalar patterns (2nd row) for two different τ values: Left column: $\tau = 0.1$. Right column: $\tau = 10$ (τ is the non-dimensional reorientation period of the flow field).

(b) The spatially-periodic persistent patterns and the exponential decay of the variance in Quatro mixer at $Pe=103$. Left pattern: for odd number of periods. Right pattern: for even number of periods.

THE SLING-EFFECT: DROPLETS IN TURBULENCE

PROJECT AIM

We study the dynamics of droplets in turbulence by making them glow and following these tagged droplets using a fast camera. This is done by dissolving European chelate molecules in the droplets, and illuminating them with a strong laser flash. This is a new diagnostic for particle-laden flows, allowing novel experiments on dispersion and preferential concentration of inertial particles in turbulence.

PROGRESS

We follow the evolution of a thin pencil-shaped line of droplets that has been selected inside a cloud churned by a strongly turbulent flow. This flow was generated in a box using loudspeaker-driven synthetic jets. The response of the droplets to the turbulent fluctuations is characterized by the Stokes number St ; in this experiment the Stokes number is scanned around $St = 1$ by changing the droplet diameter. Although inertial particles lag behind the turbulent velocity fluctuations, we find that droplet clouds spread faster than fluid elements, with the dispersion rate reaching a maximum at $St = 2$. By tagging sheets of droplets we observe the clustering of droplets. These results are a striking manifestation of the complexity of inertial particle dynamics in turbulence.

DISSERTATIONS

1. Glowing Droplets, A diagnostic of particle-laden flows, TU/e, 17 october 2013.

SCIENTIFIC PUBLICATIONS

1. Turbulent Dispersion Of Heavy Droplets. Humberto Bocanegra Evans; Nico Dam; Willem van de Water, ETC 14, 1-4 september, Lyon, France.
(for this contribution Humberto received the Young Scientist Award).

PROJECTLEADERS

W van de Water, GJF van Heijst

RESEARCHTHEME

Complex dynamics of fluids

PARTICIPANTS

H Bocanegra Evans, W van de Water, NL Dam (TU/e-Wtb), GJF van Heijst

COOPERATIONS

-

FUNDED

| | |
|--------------|-------|
| FOM | |
| University | - |
| FOM | 100 % |
| STW | - |
| NWO Other | - |
| Industry | - |
| TNO | - |
| GTI | - |
| EU | - |
| Scholarships | - |

START OF THE PROJECT

2009

INFORMATION

W van de Water
040 247 3443
w.v.d.water@tue.nl
www.fluid.tue.nl

The spreading of a thin (with width a few times the Kolmogorov length) line of tagged droplets in turbulence. The frames are time-averaged over many repetitions of the tagging experiment. The line of droplets widens much faster than a line of true fluid tracers.

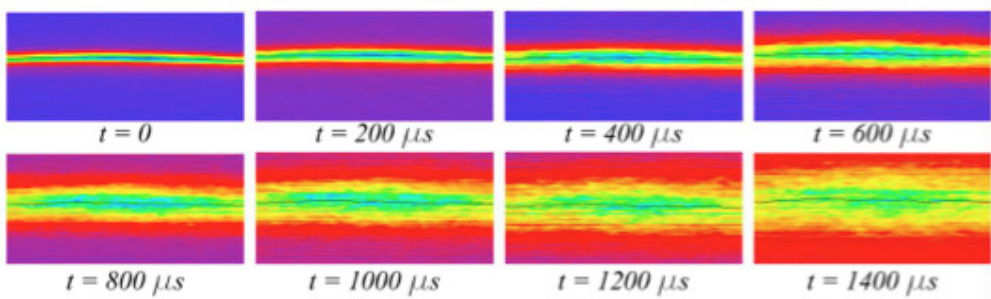

EFFECTS OF ROTATION IN QUASI-TWO-DIMENSIONAL TURBULENCE IN A THIN FLUID LAYER

PROJECT LEADERS

GJF van Heijst

RESEARCH THEME

Complex dynamics of fluids

PARTICIPANTS

M Duran Matute, LPJ Kamp,

RR Triefling, GJF van Heijst

COOPERATIONS

Z Kizner (Bar-Ilan University, Israel),

JEV Guzman

FUNDED

CONACYT

University -

FOM -

STW -

NWO Other -

Industry -

TNO -

GTI -

EU -

Scholarships 100 %

START OF THE PROJECT

2006

INFORMATION

GJF van Heijst

040 247 2722

g.j.f.v.heijst@tue.nl

www.fluid.tue.nl

PROJECT AIM

The aim of the project is to gain insight in the dynamics of vortex structures in a shallow fluid layer under the influence of background rotation. The project combines laboratory experiments and numerical flow simulations.

PROGRESS

This project has been concluded with the PhD thesis of M. Duran Matute (Nov. 2010).

DISSERTATIONS

-

SCIENTIFIC PUBLICATIONS

1. Guzmán, J.E.V., Kamp, L.P.J. & Heijst, G.J.F. van (2013). Vortex dipole collision with a sliding wall. *Fluid Dynamics Research*, 45(4), 1-12.
2. Kizner, Z., Makarov, V., Kamp, L.P.J. & Heijst, G.J.F. van (2013). Instabilities of the flow around a cylinder and emission of vortex dipoles. *Journal of Fluid Mechanics*, 730, 419-441.

A NEW WAY OF UNDERSTANDING CHAOTIC WIND BURSTING AT NIGHT

PROJECT AIM

The project aims to find the physical mechanism that drives intermittent (discontinuous) turbulence in the nocturnal atmospheric boundary layer. During intermittency, periods with 'laminar' flow are interrupted by chaotic bursts of turbulence and a significant transport of heat, moisture and momentum occurs. Key tools are theoretical analyses combined with Direct Numerical Simulation (DNS) techniques.

PROGRESS

In a nocturnal atmospheric boundary layer with clear skies and weak wind a laminarization of the flow may occur which means that the turbulence may suddenly become very weak, known as the collapse of turbulence. This laminarization generates an acceleration of the flow. In nature, this may lead to a regeneration of turbulence due to the related shear production which creates instabilities. Nieuwstadt (2005) using DNS found a critical cooling rate for which the turbulence may not survive. However, no regeneration of turbulence has been shown in the literature. In the present study we focus on the mechanism of revival of turbulence in a stratified channel flow using a DNS model and a simple similarity model. We want to prove that a regeneration of turbulence is possible after the laminarization by enhancing it. We want to also demonstrate that if enough shear is set as initial condition, the turbulence will survive beyond the critical cooling.

DISSERTATIONS

-

SCIENTIFIC PUBLICATIONS

1. Baas, P., Wiel, B.J.H. van de, Brink, L. van den & Holtslag, A.A.M. (2013). Composite hodographs and inertial oscillations in the nocturnal boundary layer. Quarterly Journal of the Royal Meteorological Society, 138(663B), 528-535.
2. Donda, J.M.M., Wiel, B.J.H. van de, Bosveld, F.C., Beyrich, F., Heijst, G.J.F. van & Clercx, H.J.H. (2013). Predicting nocturnal wind and temperature profiles based on external forcing parameters. Boundary-Layer Meteorology, 146(1), 103-117.
3. Holtslag, A.A.M., Svensson, G., Basu, S, Beare, B., Beljaars, A.C.M., Bosveld, F.C., Cuxart, J., Lindvall, J., Steeneveld, G.J., Tjernstroem, M & Wiel, B.J.H. van de (2013). Stable atmospheric boundary layers and diurnal cycles : challenges for weather and climate models. Bulletin of the American Meteorological Society, 94(11), 1691-1706.

PROJECT LEADERS

BJH van de Wiel , HJH Clercx,
GJF van Heijst

RESEARCH THEME

Complex dynamics of fluids

PARTICIPANTS

JMM Donda, BJH van de Wiel,
IGS van Hooijdonk, HJH Clercx,
GJF van Heijst

COOPERATIONS

A Moene (WUR), H Jonker (TUD),
P Baas (KNMI)

FUNDED

Vidi NWO-ALW
University -
FOM -
STW -
NWO Other 100 %
Industry -
TNO -
GTI -
EU -
Scholarships -

START OF THE PROJECT

2010

INFORMATION

BJH van de Wiel
040 247 4285
b.j.h.v.d.wiel@tue.nl
www.fluid.tue.nl

PROJECT LEADERS

F Toschi, HJH Clercx

RESEARCH THEME

Complex dynamics of fluids

PARTICIPANTS

F Tesser, P Perlekar, HJH Clercx,
F Toschi, JCH Zeegers

COOPERATIONS

R Benzi (Univ. Tor Vergata, Italy),
L Brunsveld (BMT, TU/e),
MH Jensen (Niels Bohr Institute,
Denmark), DR Nelson (Harvard
University, USA), S Pigolotti
(Universidad politécnica de
Cataluña, Spain)

FUNDED

| | |
|--------------|-------|
| FOM | |
| University | - |
| FOM | 100 % |
| STW | - |
| NWO Other | - |
| Industry | - |
| TNO | - |
| GTI | - |
| EU | - |
| Scholarships | - |

START OF THE PROJECT

2011

INFORMATION

F Toschi
040 247 3911
f.toschi@tue.nl
www.fluid.tue.nl

PROJECT AIM

Population dynamics deals with the study of birth, death and growth processes of biological species. These processes are severely affected by the local ecosystems, by the presence of nutrients, and by the local population density, moreover all these factors can be strongly influenced in a liquid environment by the presence of a flow. Effects can be visible at macroscales in terms of strong non homogeneities. The aim of the present project is to validate the continuum model for the growth of populations extending it to flow conditions, using a combination of dedicated experiments of growth of bacteria in microfluidic devices and numerical discrete particle simulations.

PROGRESS

From the experimental side different microfluidic devices have been considered and tested in order to perform a suitable environment for the growth of a colony of bacteria with and without flow. On the numerical side, discrete particles simulations have been run in 1 and 2 spatial dimensions with two different species competing under the influence of several flow fields. We are analyzing how an advection by a hydrodynamic flow can induce advantage among species.

DISSERTATIONS

-

SCIENTIFIC PUBLICATIONS

1. Perlekar, P., Benzi, R., Nelson, D.R. & Toschi, F. (2013). Cumulative compressibility effects on slow reactive dynamics in turbulent flows. *Journal of Turbulence*, 14(3), 161-169.
2. Pigolotti, S., Benzi, R., Perlekar, P., Jensen, M.H., Toschi, F. & Nelson, D.R. (2013). Growth, competition and cooperation in spatial population genetics. *Theoretical Population Biology*, 84, 72-86.

Two equally fit types of E.coli naturally demix at the front while the colony grows radially on an agarplate from an initial mixed population.

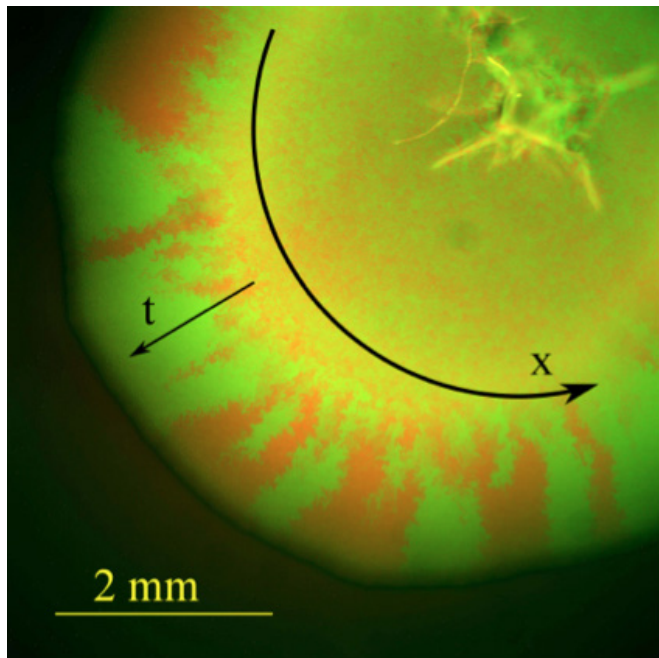

HOW GRAVITY, SHEAR AND COALESCENCE MODIFY THE DROPLET SIZE DISTRIBUTION

PROJECT AIM

The goal is to address the basic phenomenology of droplets under realistic situations, the focus being on large-scale behavior. In this study the focus will be on the effects of gravity and of shear on droplet transport and collision rates.

PROGRESS

Work on the interpolation methods has been finished with a paper about the efficiency of different interpolation methods. Further, shear has been implemented in the spectral code. The implementation has been validated and first runs have been executed. We are investigating the influence of shear on the gravitational settling of particles. First results show a drift velocity for heavy particles in the horizontal direction while the shear velocities are directed in the vertical direction.

DISSERTATIONS

-

SCIENTIFIC PUBLICATIONS

1. Hinsberg, M.A.T. van, Thijs Boonkamp, J.H.M. ten, Toschi, F. & Clercx, H.J.H. (2013). Optimal interpolation schemes for particle tracking in turbulence. *Physical Review E*, 87(4), 043307-1/8.

PROJECT LEADERS

F Toschi, HJH Clercx, GJF van Heijst

RESEARCH THEME

Complex dynamics of fluids

PARTICIPANTS

MAT van Hinsberg, HJH Clercx,
F Toschi

COOPERATIONS

L Biferale (Rome, Italy), P Perlekar
(TIFR, Hyderabad, India), J ten Thijs
Boonkamp (W&I-TU/e)

FUNDED

| | |
|--------------|-------|
| FOM | |
| University | - |
| FOM | 100 % |
| STW | - |
| NWO Other | - |
| Industry | - |
| TNO | - |
| GTI | - |
| EU | - |
| Scholarships | - |

START OF THE PROJECT

2011

INFORMATION

HJH Clercx
040 247 2680
h.j.h.clercx@tue.nl

F Toschi
040 247 3911
f.toschi@tue.nl
www.fluid.tue.nl

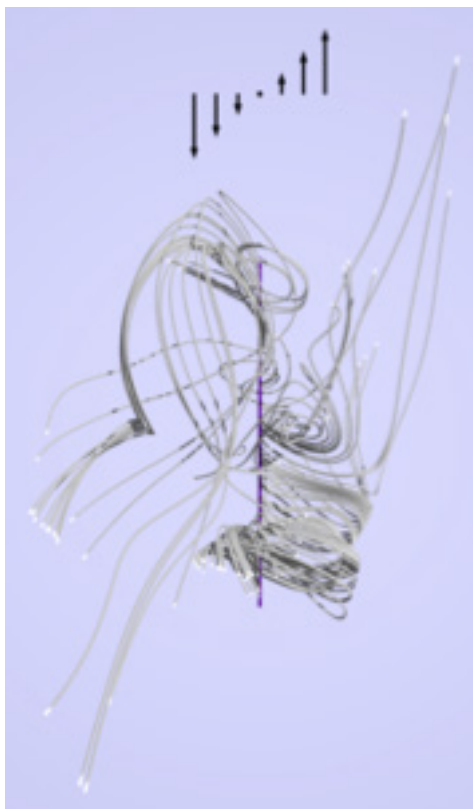

The figure shows the advection of tracers in a homogeneous shear flow

PROJECTLEADERS

HJH Clercx, GJF van Heijst

RESEARCHTHEME

Complex dynamics of fluids

PARTICIPANTS

VH Fernandes, LPJ Kamp,
GJF van Heijst, HJH Clercx

COOPERATIONS

N Lopes Cardozo (TU/e-TN),
R Jaspers (TU/e-TN),
M de Baar (FOM; TU/e-Wtb)
M Lauret (TU/e-Wtb)

FUNDED

| | |
|--------------|-------|
| TU/e | |
| University | 100 % |
| FOM | - |
| STW | - |
| NWO Other | - |
| Industry | - |
| TNO | - |
| GTI | - |
| EU | - |
| Scholarships | - |

START OF THE PROJECT

2010

INFORMATION

HJH Clercx
040 247 2680
h.j.h.clercx@tue.nl

GJF van Heijst
040 247 2722
g.j.f.v.heijst@tue.nl
www.fluid.tue.nl

PROJECT AIM

Large-scale coherent flows play an important role both in geophysical fluids and in fusion since they interact with the turbulence and can give rise to transport barriers. It turns out that these phenomena in fluids and plasmas can be described by the same equation. Therefore a relatively simple fluid dynamics experiment is proposed with the aim to study how zonal flows affect turbulence and turbulent transport and how these flows are sustained in the improved confinement mode. Comparison of fluids and plasmas by experiments and numerical simulations are an integral part of this research. In this project visualisation of the effect of flow on turbulence is a key element, whereas the fluid dynamics experiment will also serve as a test bed for control methods (link with project "Control of plasma transport by plasma flow" which is being conducted at Dept. Mech. Engineering, TU/e).

PROGRESS

The numerical investigation initiated in the previous year has been completed. This numerical study includes the investigation of monopoles, dipoles and two-dimensional forced turbulence, under the effect of shear imposed either by a Couette flow or a Poiseuille flow). As an outcome of this study we could: 1) confirm the results obtained in previous studies related to the monopole interacting with a shear flow, 2) understand the mechanisms underlying the interaction of a dipole with shear and, as a result, 3) define an analytical expression that approximates the dipole trajectories for different levels of shear, and finally, 4) infer the effect of shear on the evolution in time of the kinetic energy of a 2D forced turbulent flow. Moreover, the experimental investigation of a dipole in a shear flow was started. In this experiment we look at the effect of the shear on a perpendicularly injected dipole. The experimental results will be confronted with the numerical simulations.

DISSERTATIONS

-

SCIENTIFIC PUBLICATIONS

1. Lauret, M., Kamp, L.P.J., Heijst, G.J.F. van, Baar, M.R. de & Nijmeijer, H. (2013). Experimental stabilisation of 2D vortex patterns using time-dependent forcing. *Europhysics Letters*, 104(2), 24003-1/6.

ROTATING RB TURBULENCE: EXPERIMENTS

PROJECT AIM

This project focusses on exploring with 3D Particle Tracking Velocimetry (3D-PTV) how the Lagrangian dynamics of (fluid) particles can be utilized for turbulent state characterization, how the flow transition from one state to the other in rotating convection will affect the Lagrangian statistics of (fluid) particles, and how particle and thermal inertia affect particle dynamics in (rotating) convection.

PROGRESS

So far, the literature study of the project is in progress. Besides, the current RB cell is combined with 3D-PTV system. Since the RB cell has a circular shape, reflection of LEDs light on the tubular walls deteriorates the whole tracking procedure. This problem has been resolved by usage of low pass filters and suitable fluorescent particles. The first qualitative particle tracking experiments in non-rotating RB convection is acquired.

DISSERTATIONS

-

SCIENTIFIC PUBLICATIONS

1. Kunnen, R.P.J., Clercx, H.J.H. & Heijst, G.J.F. van (2013). The structure of sidewall boundary layers in confined rotating Rayleigh-Bénard convection. *Journal of Fluid Mechanics*, 727, 509-532.
2. Kunnen, R.P.J., Corre, Y. & Clercx, H.J.H. (2013). Vortex plume distribution in confined turbulent rotating convection. *Europhysics Letters*, 104(6), 54002-1/6.

PROJECTLEADERS

HJH Clercx

RESEARCHTHEME

Complex dynamics of fluids

PARTICIPANTS

H Rajaei, HJH Clercx, RPJ Kunnen

COOPERATIONS

-

FUNDED

| | |
|--------------|-------|
| FOM | |
| University | - |
| FOM | 100 % |
| STW | - |
| NWO Other | - |
| Industry | - |
| TNO | - |
| GTI | - |
| EU | - |
| Scholarships | - |

START OF THE PROJECT

2013

INFORMATION

HJH Clercx
040 247 2680
h.j.h.clercx@tue.nl
www.fluid.tue.nl

PROJECT LEADERS

F Toschi, L Biferale (Tor Vergata, Italy)

RESEARCH THEME

Complex dynamics of fluids

PARTICIPANTS

R Scatamacchia, F Toschi

COOPERATIONS

L Biferale (Tor Vergata, Italy),
AS Lanotte (ISAC, SNR),
M Sbragaglia (Tor Vergata, Italy)

FUNDED

| | |
|---------------------------|-------|
| University of Tor Vergata | |
| University | 100 % |
| FOM | - |
| STW | - |
| NWO Other | - |
| Industry | - |
| TNO | - |
| GTI | - |
| EU | - |
| Scholarships | - |

START OF THE PROJECT

2012

INFORMATION

F Toschi
040 247 3911
f.toschi@tue.nl
www.fluid.tue.nl

PROJECT AIM

The project is a dual-degree collaboration between TU/e and University of Tor Vergata (Italy). The goal of the project is to study the behavior of few prototypical examples of complex flows and complex fluids.

PROGRESS

In the first part of the project the focus was on the dynamics of tracers and inertial particles dispersed by point sources in homogenous and isotropic turbulence velocity fields. The system is the simplest model for dispersion in the atmosphere (e.g. ashes from volcanic sources or pollutants from industrial chimneys). The massively parallel simulation with extraordinary high statistics allowed to measure, for the first time, deviations from Richardson dispersion due to finite flow velocity. Also thanks to our huge statistics we are able to characterize, in a quantitative way, the difference between tracers and inertial heavy particles dispersion.

DISSERTATIONS

-

SCIENTIFIC PUBLICATIONS

-

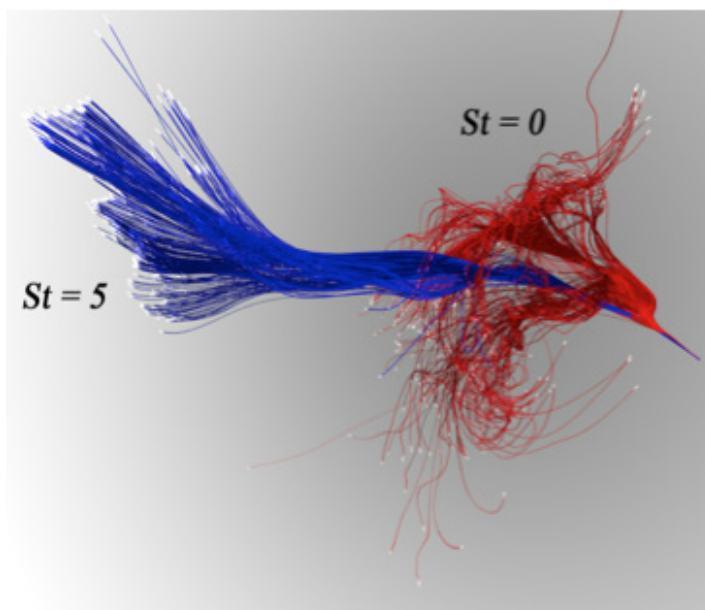

A sketch illustrating the dispersion comparison between a bunch of tracers (red) and inertial heavy particles (blue) released from a point-like source and dispersing in a homogeneous and isotropic turbulent velocity field)

UNRAVELLING 3D MIXING NEAR THE SURFACE OF ACTUATED BEADS

PROJECT AIM

This project is part of a larger research program on magneto-active mixing and catching by small beads for microfluidic biosensor applications. It concerns the full exploitation of the scavenging properties of magnetic beads in microfluidic devices, control of fluid mixing, and the enhancement of the capture of (biological) targets by the beads. Key in this process is knowledge of the unsteady streamline pattern around a translating and rotating sphere and a detailed understanding of the local mixing properties nearby the sphere surface. Quantitative information, obtained from a laboratory experiment (on macroscopic scale), combined with numerical modeling will be used to optimize the mixing and capturing processes. Actuation protocols will be devised to enhance the capture probability of target particles by the bead.

PROGRESS

A macroscopic scale experimental facility has been set up to validate the numerical/analytical findings. The fabricated sphere is capable of rotation and translation about two independent axes. Flow is induced by actuating the sphere. Neutrally buoyant polystyrene microspheres are used as passive tracers and the working fluid is silicone oil. Typical operational range for Reynolds number in such experiments is 0.001 to 0.01. Similar to our numerical work, we are looking at tracer transport in a Lagrangian framework. We employ three-dimensional particle tracking velocimetry to obtain the trajectories. The obtained trajectory information lends us to use qualitative tools like Poincaré map to classify the transport behavior to be chaotic or not. We sought for those motion protocols which would result in chaotic motion and consequently achieve good mixing. First benchmark tests have been performed.

DISSERTATIONS

-

SCIENTIFIC PUBLICATIONS

1. N.R. Moharana, M.F.M. Speetjens, R.R. Trieling and H.J.H. Clercx, Three-dimensional Lagrangian transport phenomena in unsteady laminar flows driven by a rotating sphere. *Phys. Fluids*, 25,093602 (2013).

3D Poincaré map (left panel) and its corresponding projection in the rz-plane (right panel) for a single tracer released at the position of the (red) bullet for a piecewise-steadily rotating sphere subject to artificial (nonlinear) perturbations. Corresponding period-3 foci and nodes are indicated by circles and crosses, respectively. The lines represent the 1D and 2D manifolds associated with specific triplets of period-3 foci and nodes.

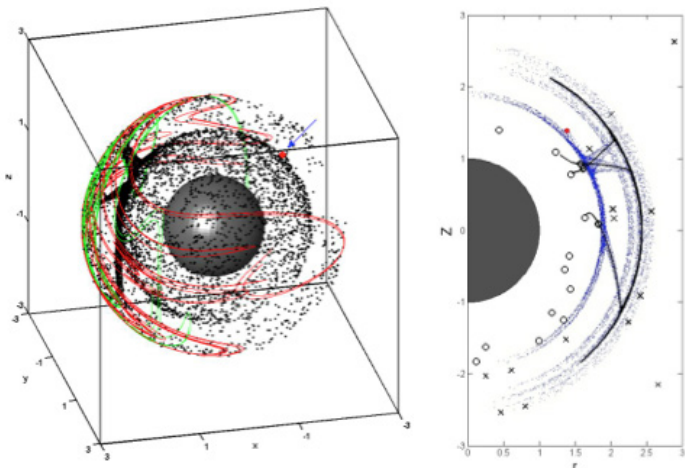

PROJECT LEADERS

HJH Clercx

RESEARCH THEME

Complex dynamics of fluids

PARTICIPANTS

NR Moharana, RR Trieling,
GJF van Heijst, HJH Clercx

COOPERATIONS

M Prins (TU/e-TN; Philips),
AM de Jong (TU/e-TN),
J den Toonder (TU/e-Wbt; Philips),
MFM Speetjens (TU/e-Wbt).

FUNDED

| | |
|--------------|-------|
| STW | |
| University | - |
| FOM | - |
| STW | 100 % |
| NWO Other | - |
| Industry | - |
| TNO | - |
| GTI | - |
| EU | - |
| Scholarships | - |

START OF THE PROJECT

2010

INFORMATION

HJH Clercx
040 247 2680
h.j.h.clercx@tue.nl

RR Trieling
040 247 2673
r.r.trieling@tue.nl
www.fluid.tue.nl

PROJECT LEADERS

HJH Clercx

RESEARCH THEME

Complex dynamics of fluids

PARTICIPANTS

RJAM Stevens, V Lavezzo,

P Perlekar, F Toschi, GJF van Heijst,

HJH Clercx

COOPERATIONS

BJ Geurts (TU/e & UT),

R Verzicco (Univ. Bari, Italy),

D Lohse (Univ. Twente), G Ahlers

(UCSB, USA), RPJ Kunnen (TU/e-

TN)

FUNDED

FOM

University -

FOM 100 %

STW -

NWO Other -

Industry -

TNO -

GTI -

EU -

Scholarships -

START OF THE PROJECT

2008

INFORMATION

HJH Clercx

040 247 2680

h.j.h.clercx@tue.nl

www.fluid.tue.nl

PROJECT AIM

The aim of this research project is threefold: 1) understanding of the effect of background rotation on Rayleigh-Bénard convection (RBC) and the role of Ekman boundary layers on the emergence of coherent structures in the flow, 2) heat transport measurements in (rotating) RBC in cylindrical convection cells, and 3) analysis of the dispersion of particles with (thermal) inertia and its subsequent feedback on the flow. For this purpose both laboratory experiments and direct numerical simulations are performed (both cylindrical geometry and channel geometry).

PROGRESS

This project has been finished with the thesis of R.J.A.M. Stevens (2011).

DISSERTATIONS

-

SCIENTIFIC PUBLICATIONS

1. Stevens, R.J.A.M., Clercx, H.J.H. & Lohse, D. (2013). Heat transport and flow structure in rotating Rayleigh-Bénard convection. *European Journal of Mechanics. B, Fluids*, 40, 41-49.

PROJECT AIM

The project aims at the development, validation and use of the lattice-Boltzmann method for the simulation of various geometries where contact line dynamics is relevant. These problems arise due to the complex geometric structure of the geometry, like in the immersion lithography and the ink-jet printhead.

PROGRESS

In this part of project we developed the multiphase axisymmetric lattice Boltzmann model [1]. The model is an extension of the standard Shan-Chen multi-phase model [1]. We validated this model for various single- and multi-phase test cases, e.g., drop oscillations and breakup of liquid cylinder (Rayleigh-Plateau instability). Furthermore, we employed the model to study the contraction of viscous ligament [2]. For the study contraction of the ligament, we compared our model with a lubrication model [T. Driessen and R. Jeurissen, IJCFD 25, 333 (2011)] (SJ), force balance model (FB) and Flow3D simulations [2].

DISSERTATIONS

-

SCIENTIFIC PUBLICATIONS

1. Chan, T.S., Srivastava, S., Marchand, A., Andreotti, B., Biferale, L., Toschi, F. & Snoeijer, J.H. (2013). Hydrodynamics of air entrainment by moving contact lines. *Physics of Fluids*, 25(7), 074105/1-19.
2. Driessen, T.W., Jeurissen, R.J.M., Wijshoff, H.M.A., Toschi, F. & Lohse, D. (2013). Stability of viscous long liquid filaments. *Physics of Fluids*, 25(6), 1-7.
3. Srivastava, S., Perlekar, P., Thije Boonkkamp, J.H.M. ten, Verma, N. & Toschi, F. (2013). Axisymmetric multiphase lattice Boltzmann method. *Physical Review E*, 88(1):013309.
4. Srivastava, S., Driessen, T.W., Jeurissen, R.J.M., Wijshoff, H.M.A. & Toschi, F. (2013). Lattice Boltzmann method to study the contraction of a viscous ligament. *International Journal of Modern Physics C*, 24(12), 1340010/1-7.

PROJECT LEADERS

F Toschi

RESEARCH THEME

Mathematical and computational methods for fluid flow analysis

PARTICIPANTS

S Srivastava, J ten Thije

Boonkkamp, F Toschi

COOPERATIONS

Océ, ASML

FUNDED

FOM

University -

FOM 100 %

STW -

NWO Other -

Industry -

TNO -

GTI -

EU -

Scholarships -

START OF THE PROJECT

2009

INFORMATION

F Toschi

040 247 3911

f.toschi@tue.nl

www.fluid.tue.nl

ATTRIBUTING THE SOURCES OF TROPOSPHERIC OZONE FROM SPACE: CONSTRAINING BIOGENIC VOC EMISSIONS AND EMISSIONS FROM BIOMASS BURNING

PROJECT LEADERS

KF Boersma, GJF van Heijst

RESEARCH THEME

Complex dynamics of fluids

PARTICIPANTS

MHA van Geel, GCM Vinken,
WW Verstraeten, KF Boersma

COOPERATIONS

KNMI, BIRA, Harvard-Smithsonian

FUNDED

NWO-VIDI

University -

FOM -

STW -

NWO Other 100 %

Industry -

TNO -

GTI -

EU -

Scholarships -

START OF THE PROJECT

2010

INFORMATION

KF Boersma

040 247 2160

k.f.boersma@tue.nl

www.fluid.tue.nl

www.knmi.nl/~boersma

PROJECT AIM

Isoprene, a volatile organic compound (VOC), is a major driver of tropospheric ozone which is produced by photochemical oxidation of VOCs. In this project, we use satellite data as top-down constraints on emissions of isoprene, and derive emissions of HCHO and NOx from biomass burning. We focus on three tasks: the first two involve biogenic emissions, the third involves biomass burning. We will first evaluate isoprene chemistry in TM5. We then proceed and apply satellite observations of HCHO columns from the GOME(-2), SCIAMACHY, and OMI instruments to better estimate isoprene emissions from biogenic sources and fires.

PROGRESS

We have implemented different isoprene oxidation mechanisms in the global 3D chemistry transport model TM5. The implemented schemes are the Epoxide Formation Mechanism and the Leuven Isoprene Mechanism (LIM). The LIM scheme is updated using reaction rates given by da Silva et al. [2010], Crounse et al. [2011], and Fuchs et al. [2013]. These new chemistry mechanisms are compared with isoprene, HCHO and OH aircraft data from both the GABRIEL and AMMA campaigns. Using updated isoprene chemistry we determined the isoprene-HCHO relationship that is necessary for the inversion of satellite HCHO data. We find that the isoprene-HCHO relationship depends on the NO₂ concentrations.

DISSERTATIONS

-

SCIENTIFIC PUBLICATIONS

-

Slope S, which represents HCHO produced from isoprene emissions, versus the tropospheric NO₂ column. CB05 is the original chemistry mechanism, LIM-J is the LIM scheme along with the updates by Fuchs et al. [2013]. The probability density function, shown inset, shows that for high NO_x concentrations the regression is not as robust as for low NO_x concentrations.

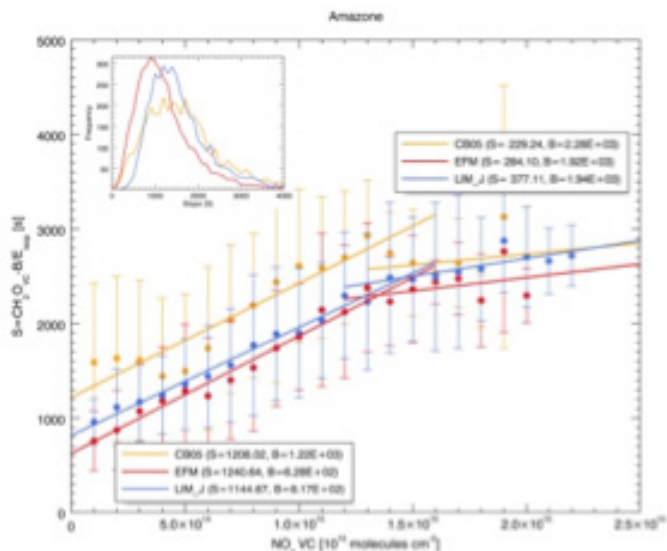

ATTRIBUTING THE SOURCES OF TROPOSPHERIC OZONE FROM SPACE: MAPPING NO₂ EMISSIONS WITH SATELLITE OBSERVATIONS

PROJECT AIM

Ozone is produced in the troposphere by photochemical oxidation of volatile organic compounds (VOCs) and CO in the presence of nitrogen oxides. These precursors have large and changing anthropogenic sources and some natural sources may be perturbed by climate change. In this project, we will exploit NO₂ column data from SCIAMACHY, OMI, and GOME(-2) as top-down constraints on emissions of NO_x, building on earlier work with GOME and OMI. We will first improve the description of a number of physical and chemical processes relevant to NO_x emissions in the global models we will use (TM5, GEOS-Chem). We then apply satellite observations of NO₂ columns from the GOME(-2), SCIAMACHY, and OMI instruments to better estimate NO_x emissions from different categories, including international shipping, lightning, biomass burning, and anthropogenic emissions.

PROGRESS

The representation of ship emissions in the GEOS-Chem chemistry transport model was improved, and simulated NO₂ columns were compared to consistent OMI satellite observations. Relative differences between simulated and observed NO₂ columns have been used to constrain ship emissions in four European seas (the Baltic Sea, the North Sea, the Bay of Biscay and the Mediterranean Sea). OMI top-down European ship NO_x emissions amount to 0.96 Tg N for 2005, and 1.0 Tg N for 2006 (11–15% lower than the bottom-up EMEP ship emission inventory). This work was presented at Physics@FOM Veldhoven, the European Geosciences Union General Assembly 2013, and the 6th International GEOS-Chem Meeting. This work will be extended by constraining ship emissions in these seas for more years. Furthermore the candidate has started work on constraining worldwide soil NO_x emissions by OMI NO₂ observations for 2005.

DISSERTATIONS

-

SCIENTIFIC PUBLICATIONS

-

PROJECT LEADERS

KF Boersma, PF Levelt,
GJF van Heijst

RESEARCH THEME

Complex dynamics of fluids

PARTICIPANTS

GCM Vinken, MHA van Geel,
WW Verstraeten, KF Boersma

COOPERATIONS

KNMI, Harvard University

FUNDED

| | |
|--------------|-------|
| NWO-VIDI | |
| University | - |
| FOM | - |
| STW | - |
| NWO Other | 100 % |
| Industry | - |
| TNO | - |
| GTI | - |
| EU | - |
| Scholarships | - |

START OF THE PROJECT

2010

INFORMATION

KF Boersma
040 247 2160
k.f.boersma@tue.nl
www.fluid.tue.nl
www.knmi.nl/~boersma

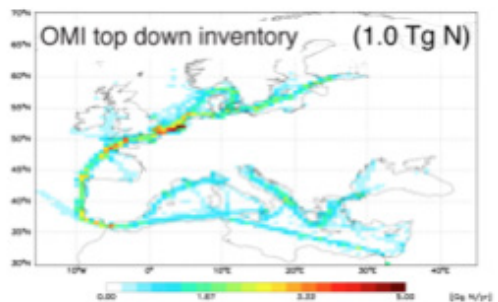
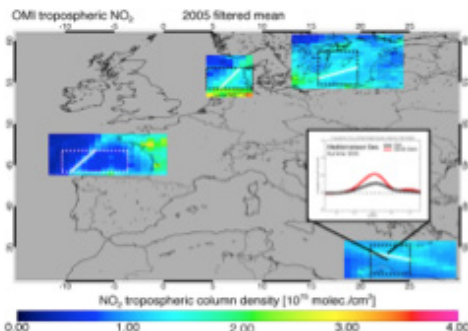

Filtered OMI observed NO₂ columns (left panel) show ship tracks in four European seas. Inset shows along-ship-track average of simulated (red) and OMI observed (black) NO₂ columns. The relative difference of these columns was used to create the OMI top-down ship emissions inventory for 2005 (right panel)

ATTRIBUTING THE SOURCES OF TROPOSPHERIC OZONE FROM SPACE: EVALUATING TIME SERIES OF FREE TROPOSPHERIC OZONE OBSERVED FROM SPACE WITH A CHEMICAL TRANSPORT MODEL

PROJECT LEADERS

KF Boersma, GJF van Heijst

RESEARCH THEME

Complex dynamics of fluids

PARTICIPANTS

WW Verstraeten, GCM Vinken,
MHA van Geel, KF Boersma

COOPERATIONS

KNMI, JPL

FUNDED

NWO-VIDI

University -

FOM -

STW -

NWO Other 100 %

Industry -

TNO -

GTI -

EU -

Scholarships -

START OF THE PROJECT

2011

INFORMATION

WW Verstraeten

040 247 2160

w.w.verstraeten@tue.nl

www.fluid.tue.nl

PROJECT AIM

Tropospheric ozone is an important greenhouse gas and a global air pollutant. The fact that ozone in the troposphere reflects the complex interplay of varying spatio-temporal emissions of precursors together with meteorological conditions and atmospheric transport patterns, challenges in-depth interpretation of ozone observations. Spaceborne sensors are excellent tools to map tropospheric ozone patterns thanks to their extensive spatial coverage and frequent overpasses, but understanding and attributing tropospheric ozone concentrations and sources to the observations requires advanced chemical transport models.

PROGRESS

In our study TES V004 nadir O₃ profiles were validated with more than 4400 coinciding ozonesonde measurements taken across the world from the World Ozone and Ultraviolet Radiation Data Centre (WOUDC) during the period 2005-2010. An important quality indicator of the TES O₃ data is whether any biases are constant in time or reflect some degree of instrument degradation. Generally, TES V004 O₃ retrievals are biased high by 2-7 ppbv (7-15%) in the troposphere. Focusing on the 464 hPa retrieval level, broadly representative for free tropospheric O₃, we find differences in the TES biases for the Tropics (+3 ppbv, +7%), sub-tropics (+5 ppbv, +11%), and northern (+7 ppbv, +13%) and southern mid-latitudes (+4 ppbv, +10%) as shown in the Figure below. Attributing the sources of ozone over China is in process.

DISSERTATIONS

-

SCIENTIFIC PUBLICATIONS

- Verstraeten, W.W., Boersma, K.F., Zörner, J., Allaart, M.A.F., Bowman, K.W. & Worden, J.R. (2013). Validation of six years of TES tropospheric ozone retrievals with ozonesonde measurements: implications for spatial patterns and temporal stability in the bias. *Atmos. Meas. Tech.*, 6, 1413-1423, 2013.

Mean 2005-2010 TES bias in O₃ at 464 hPa per latitude zone (black symbols) and their standard errors (including data pairs numbers and standard errors). Grey symbols indicate the seasonal mean biases and their standard errors. NMLT: Northern mid-latitudes; NSTropics: Northern sub-tropics; SLMT: Southern lower and mid-latitudes.

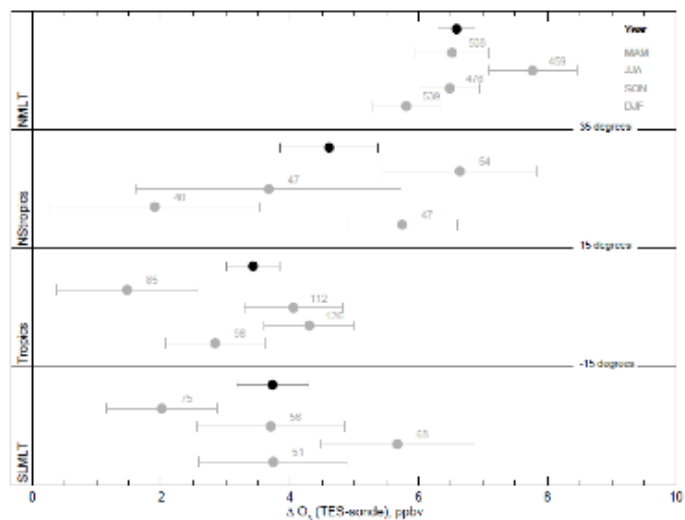

DYNAMICS, COLLISIONS AND COALESCENCE OF DROPLETS IN TURBULENCE

PROJECT AIM

In this experimental project the motion of droplets with diameter of 10 to 50 micrometer in an air-filled turbulence chamber are tracked with 3D particle tracking velocimetry (PTV). The focus is on interactions between droplets (collision or coalescence) and the effect of gravity. We also study the evolution in time of the droplet size distribution with phase-Doppler anemometry (PDA). Turbulence-induced droplet coalescence is the process responsible for rapid precipitation formation; it is, however, not well understood.

PROGRESS

PIV measurements performed in order to characterize the flow inside the turbulence chamber. Also 3D-PTV measurements performed to investigate the influence of turbulence on droplet behavior. For statistical purposes, both measurements are still in progress but already we have promising findings about the settling velocity of the heavy droplets and also about a phenomenon that is called in literature "the sling effect" and/or "sweep-stick mechanism". Additionally some preliminary Interferometric Particle Imaging (IPI) measurements have been performed to quantify the droplet size distribution.

DISSERTATIONS

-

SCIENTIFIC PUBLICATIONS

-

PROJECTLEADERS

HJH Clercx, GJF van Heijst

RESEARCHTHEME

Complex dynamics of fluids

PARTICIPANTS

AM Yavuz, MAT van Hinsberg,
RPJ Kunnen, HJH Clercx, F Toschi,
GJF van Heijst

COOPERATIONS

BJ Geurts (UT)

FUNDED

| | |
|--------------|-------|
| FOM | |
| University | - |
| FOM | 100 % |
| STW | - |
| NWO Other | - |
| Industry | - |
| TNO | - |
| GTI | - |
| EU | - |
| Scholarships | - |

START OF THE PROJECT

2011

INFORMATION

HJH Clercx
040 247 2680
h.j.h.clercx@tue.nl

RPJ Kunnen
040 247 3194
r.p.j.kunnen@tue.nl
www.fluid.tue.nl

The turbulence chamber at TU/e.

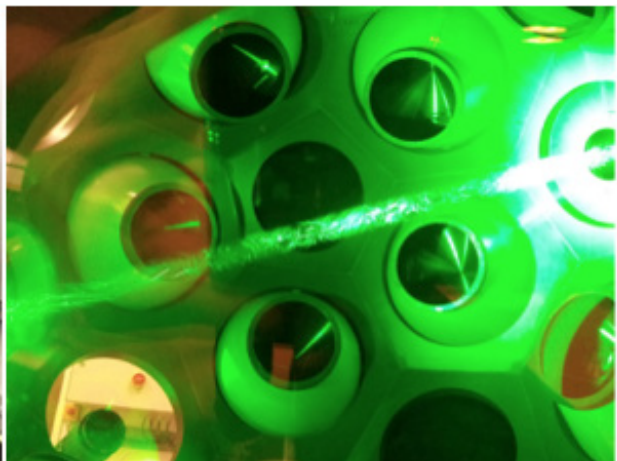
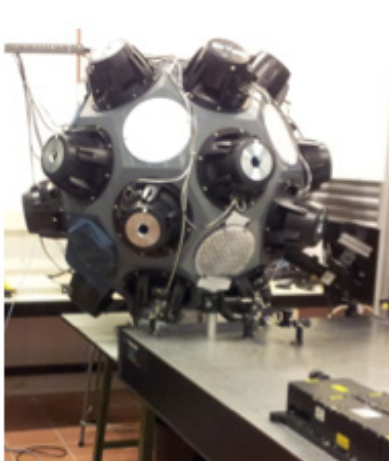

EXPERIMENTAL STUDY OF THE DYNAMICS OF DROPLETS IN TURBULENT SPRAYS AND CLOUDS

PROJECT LEADERS

HJH Clercx, GJF van Heijst

RESEARCH THEME

Complex dynamics of fluids

PARTICIPANTS

DD van der Voort, HJH Clercx,
NJ Dam (TU/e-Wtb), GJF van Heijst,
W van de Water

COOPERATIONS

M Meijer (TU/e-Wtb), AM Yavuz

FUNDED

FOM
University -
FOM 100 %
STW -
NWO Other -
Industry -
TNO -
GTI -
EU -
Scholarships -

START OF THE PROJECT

2013

INFORMATION

GJF van Heijst
040 247 2722
g.j.f.v.heijst@tue.nl
www.fluid.tue.nl

PROJECT AIM

The main aims are 1) to experimentally investigate the breakup of turbulent jets and sprays by means of phosphorescence, 2) to study the behavior of individual droplets in turbulent sprays and in zero-mean homogeneous isotropic turbulence by Lagrangian measurements, and 3) to explore droplet dispersion in these systems.

PROGRESS

A new setup has been built capable to investigate both the breakup (using internal excitation of the phosphorescent fluid) and dispersion of turbulent high speed liquid sprays in air. Initial experiments have been performed to test the capability of the measurement technique, as shown in figure 1. Furthermore, a small volume of homogeneous isotropic zero-mean turbulence has been created in a turbulence chamber and subsequently calibrated using PIV measurements. This is the first step towards determining droplet dynamics in turbulence when combined with the tracking ability that is inherent to phosphorescence.

DISSERTATIONS

-

SCIENTIFIC PUBLICATIONS

-

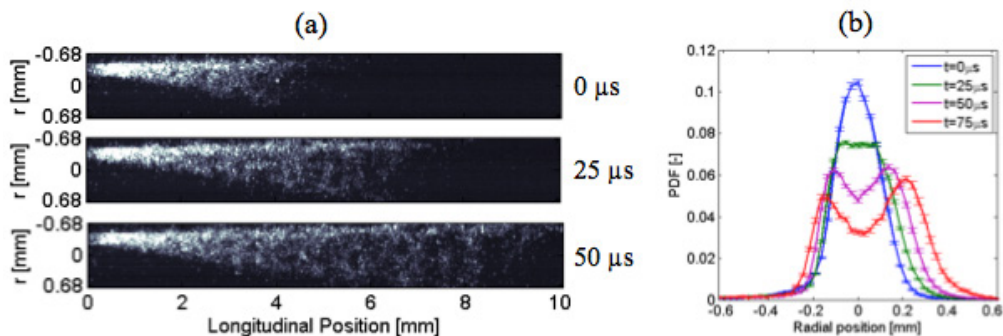

High speed breakup (a) of phosphorescent hollow cone jet developed over 50 μs and the measured droplet distribution (b) using laser sheet tagging.

PROJECT AIM

Develop a system to visualize and analyze the flow around a human swimmer and extract information from resolved flow field of interest for trainers, coaches and sports scientists. Visualization will be done by means of a bubble system and PIV routine. Furthermore the influence of different and new kinds of feedback to swimmers will be tested on a group of swimmers. In the end the goal is to contribute to improved performance of Dutch elite swimmers.

PROGRESS

Laboratory tests are performed to generate bubble curtains which have to satisfy several conditions. Simulations to study bubble dynamics are performed, with the goal to get an idea about the resolutions of the flow field that can be achieved using bubbles as tracer particles. In the first year we are performing statistical analysis on the bubble curtains in the laboratory and finishing the construction of the bubble system in the swimming pool. Simulations of the flow around a swimmer's hand have been carried out with an immersed boundary technique.

DISSERTATIONS

-

SCIENTIFIC PUBLICATIONS

-

PROJECTLEADERS

HJH Clercx

RESEARCHTHEME

Complex dynamics of fluids

PARTICIPANTS

J van Houwelingen, PJ Beek,
HJH Clercx, GJF van Heijst,
RPJ Kunnen, W van de Water

COOPERATIONS

R Verzicco (Roma, Italy),
PJ Beek (VU), J Westerweel (TUD),
InnoSport

FUNDED

| | |
|--------------|-------|
| STW | |
| University | - |
| FOM | - |
| STW | 100 % |
| NWO Other | - |
| Industry | - |
| TNO | - |
| GTI | - |
| EU | - |
| Scholarships | - |

START OF THE PROJECT

2013

INFORMATION

HJH Clercx
040 247 2680
h.j.h.clercx@tue.nl

W van de Water
040 247 3443
w.v.d.water@tue.nl
www.fluid.tue.nl

PROJECT LEADERS

BJH van de Wiel, HJH Clercx

RESEARCH THEME

Complex dynamics of fluids

PARTICIPANTS

IGS van Hooijdonk, HJH Clercx,
BJH van de Wiel

COOPERATIONS

-

FUNDED

NWO-ALW

University -

FOM -

STW -

NWO Other 100 %

Industry -

TNO -

GTI -

EU -

Scholarships -

START OF THE PROJECT

2013

INFORMATION

BJH van de Wiel

040 247 4285

b.j.h.v.d.wiel@tue.nl

www.fluid.tue.nl

PROJECT AIM

A well-known phenomenon in the atmospheric boundary layer is the sudden decrease in turbulence intensity. This generally occurs in the case of weak winds (shear production) strong cooling at the surface (buoyant destruction). Data analysis of atmospheric data (Cabauw weather tower), theoretical analysis and direct numerical simulation are used to investigate this phenomenon. Though originally the research is motivated by meteorological application, we also aim to obtain fundamental insight in the laminarisation of turbulence near a cooled surface.

PROGRESS

Approximately 4500 nights were analysed and classified. Ensemble averages represent typical behaviour of nights with similar characteristics. The resulting climatological data set is compared with the results from theoretical analysis, predicting the occurrence of a quasi-laminar atmospheric boundary layer and a good agreement is found. The final output is a classification parameter that indicates unambiguously if laminarisation occurs or not. An article on these results is expected to be finished in the beginning of 2014.

DISSERTATIONS

-

SCIENTIFIC PUBLICATIONS

-

Here the maximum supply of heat to the ground is presented (ensemble averaged field measurements) as a function of stability (Richardson number). When more heat is withdrawn by radiative emission then can be supplied (the top of the parabolic curve) a laminarisation is inevitable.

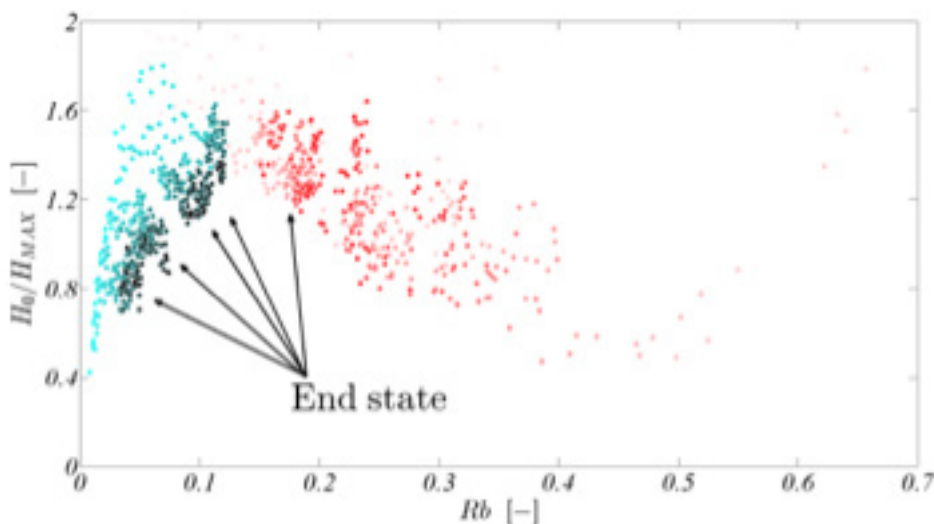

PROJECT AIM

The aim of the present project is to investigate numerically and develop models for the statistical properties of hydrodynamics stresses on algae in turbulent environments at different cell concentrations. In the recent past the small-scale statistical properties of (point-wise) particles in turbulence, like their acceleration, have been investigated experimentally and numerically. Numerical methods have been developed and employed to study the rheological properties of very dense suspensions of cells in simple laminar flows. Here we will need to combine the physics and the numerical methods of these previous studies and push both considerably further to challenge the turbulence transport and the statistical properties of (non)-Newtonian dense cell suspensions.

PROGRESS

The objectives achieved till now are:

1. Training in C programming, parallel computing and learning of the existing computer code.
2. Study of fundamental aspects of the problem.
3. Development of a 2D LBM code to be used in further simulations for testing and benchmarking.

DISSERTATIONS

-

SCIENTIFIC PUBLICATIONS

-

PROJECTLEADERS

F Toschi, HJH Clercx

RESEARCHTHEME

Mathematical and computational methods for fluid flow analysis

PARTICIPANTS

A Gupta, F Toschi, HJH Clercx.

COOPERATIONS

Shell-NWO/FOM

FUNDED

| | |
|---------------|-------|
| Shell-NWO/FOM | |
| University | - |
| FOM | 100 % |
| STW | - |
| NWO Other | - |
| Industry | - |
| TNO | - |
| GTI | - |
| EU | - |
| Scholarships | - |

START OF THE PROJECT

2013

INFORMATION

F Toschi
040 247 3911
f.toschi@tue.nl
www.fluid.tue.nl

STICK TO THE SURFACE!

PROJECT LEADERS

HJH Clercx, F Toschi

RESEARCH THEME

Complex dynamics of fluids

PARTICIPANTS

G Di Staso, J van Dijk, S Nijdam,
GMW Kroesen, F Toschi, HJH Clercx

COOPERATIONS

ASML

FUNDED

STW

University -

FOM -

STW 100 %

NWO Other -

Industry -

TNO -

GTI -

EU -

Scholarships -

START OF THE PROJECT

2013

INFORMATION

HJH Clercx

040 247 2680

h.j.h.clercx@tue.nl

www.fluid.tue.nl

PROJECT AIM

Main aim is the development of numerical tools to characterize transport of particle debris under combined effects of fluid dynamics and plasma physics. Our aim is to study when and how particles are released from surfaces under the conditions present in EUV lithography tool (hydrodynamic and rarefied gas flows, in presence of harsh and weak plasma environment). This will lead to a clear picture of what occurs inside the tool's plasma and main chambers and how it is possible to influence and, in perspective, prevent potential damaging dust to be released from surfaces.

PROGRESS

The initial activities focused on studying relevant literature: for the hydrodynamic regime on Lattice Boltzmann Method (LBM) and on techniques and algorithms for simulating the dynamics of solid particles in fluids, and for the rarefied gas flow conditions on the comprehension of different numerical methods for flow simulations (LBM for mild rarefied conditions and Direct Simulation Monte Carlo (DSMC) for higher Knudsen number regime). This has led to the conclusion that, for correctly treating the problem at hand, a hybrid DSMC-LBM simulation tool capable to cover both rarefied and continuum regime should be developed. A next activity was aimed to understand the general architecture and implementation features of the LBM code available within the WDY group. Moreover, attendance to Gas Discharges course allowed to get some knowledge of physical phenomena involved in plasma physics.

DISSERTATIONS

-

SCIENTIFIC PUBLICATIONS

-

EXPERIMENTS ON LAGRANGIAN STATISTICS IN ROTATING TURBULENCE

PROJECT AIM

It is the aim of this research project to develop insight in the Lagrangian statistics of rotating turbulence and the single- and pair-dispersion properties of small particles in rotating turbulence. For this purpose an existing 3D Particle Tracking Velocimetry method will be made suitable for rotating turbulence experiments.

PROGRESS

This project has been finished with the thesis of L. Del Castello (Oct. 2010).

DISSERTATIONS

-

SCIENTIFIC PUBLICATIONS

1. Del Castello, L. & H.J.H. Clercx (2013), Geometrical statistics of the vorticity vector and the strain rate tensor in rotating turbulence, *J. of Turbul.* 14, 19-36.

PDFs of the horizontal (left) and vertical (right) components of the acceleration for all (non-)rotating experiments. The emergence of large scale columnar flow structures is reflected in these PDFs. Rotation enhances the tails of the horizontal acceleration PDFs while those of the vertical acceleration PDFs are suppressed.

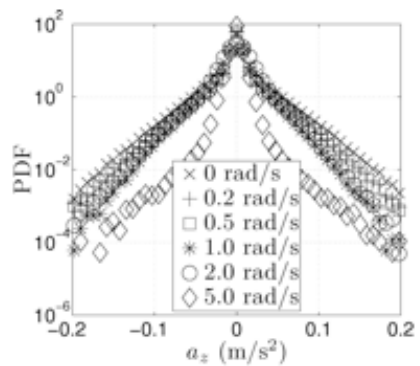
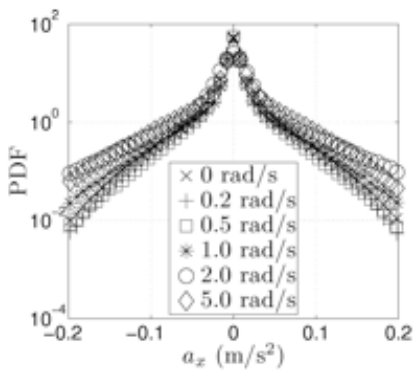

PROJECT LEADERS

HJH Clercx

RESEARCH THEME

Complex dynamics of fluids

PARTICIPANTS

L Del Castello, HJH Clercx

COOPERATIONS

C Cambon (ENS Lyon, France),

A Tsinober (Univ. Tel Aviv, Israel),

W Kinzelbach (ETH Zürich,

Switzerland), B Luethi (ETH Zürich,

Switzerland)

FUNDED

NWO-VICI

University -

FOM -

STW -

NWO Other 100 %

Industry -

TNO -

GTI -

EU -

Scholarships -

START OF THE PROJECT

2005

INFORMATION

HJH Clercx

040 247 2680

h.j.h.clercx@tue.nl

www.fluid.tue.nl



Prof.dr.ir. OCG Adan



Prof.dr.ir. K Kopinga

In the group Transport in Permeable Media, TPM, of the department of Applied Physics at the Eindhoven University of Technology research is performed on transport and phase changes in permeable media. Our mission is to advance materials technology through an in-depth understanding of transport physics in permeable media, in support of various technology domains, such as high tech materials, petro physics and thermal energy storage. The interaction between transport of fluids and solutes, phase changes and material response on different scale levels -typically in the micrometer to millimeter range- forms the core of our research activities. Inherently, interdisciplinarity is in TPMs genes, encompassing transport physics, materials science, chemistry and biology. The experiment is at the heart of the group, which is due to the unique opportunities of our MRI infrastructure, consisting of nine home-built or -modified scanners operating at fields ranging from 0.7 – 4.7 T. TPMs research profile is based on use-inspired basic research. Consequently, interaction with industrial players forms a cornerstone in our approach. For this reason, fruitful partnerships exist with TNO, AkzoNobel and Océ. The work is mainly funded by the Dutch Technology Foundation (STW), Materials innovation institute (M2i), the European Commission and various industrial partners.

WATER TRANSPORT THROUGH COATINGS ON WOOD

PROJECT AIM

An important reason to apply coatings on wood is to protect wood against water. In order to use waterborne coatings for wood care the main factors determining transport through these coatings have to be understood. Waterborne coatings are intrinsically more sensitive to water. Further, the influences of wood on the coating structure and permeability have to be understood. In this project the migration of water through waterborne coatings on wood will be studied with NMR imaging tools. NMR imaging is very suitable tool for visualizing water distributions in the wood and the coating. Further, NMR also gives information about the state of water (bound or free) and plasticization effects (polymer-water interactions).

PROGRESS

To investigate water transport through coatings on wood, we started to analyse transport through the wood itself. Oak, teak, pine sapwood and pine hardwood were selected as the wood types which covers a whole range of low to high density wood. The first experimental part on uncoated wood was to do the calibration of moisture content for each type with the low resolution NMR. The calibration results showed a good linear relation between NMR signal and moisture content. Allowing us to directly calculate the amount of water from the NMR signal during wetting and drying of wood samples. Relaxation analyses were performed to understand the state of water within the wood, e.g. bound or free water in lumen or voids. Coating were formulated, using well known composition; 3 type of coatings, WB alkyd, SB alkyd and WB acrylic were prepared specifically for this project. Experiments were performed to measure the drying (curing) profiles of the coating systems using high resolution NMR. After the separate investigation on wood and coatings, the next step is to study water permeability on different combinations of coating and wood.

DISSERTATIONS

-

SCIENTIFIC PUBLICATIONS

-

PROJECTLEADERS

SJF Erich, HP Huinink, OCG Adan

RESEARCHTHEME

Complex dynamics of fluids

PARTICIPANTS

O Gezici

COOPERATIONS

TNO

FUNDED

AKZO/TNO

University -

FOM -

STW -

NWO Other -

Industry 100 %

TNO -

GTI -

EU -

Scholarships -

START OF THE PROJECT

2012

INFORMATION

B Erich

040 247 3830

s.j.f.erich@tue.nl

INFLUENCE OF WATER-POLYMER INTERACTIONS ON WATER TRANSPORT IN MULTILAYER COATINGS

PROJECT LEADERS

OCG Adan, HP Huinink

RESEARCH THEME

Complex dynamics of fluids

PARTICIPANTS

V Baukh

COOPERATIONS

AkzoNobel Automotive & Aerospace Coatings, TNO

FUNDED

| | |
|--------------|-------|
| AkzoNobel | |
| University | - |
| FOM | - |
| STW | - |
| NWO Other | - |
| Industry | 100 % |
| TNO | - |
| GTI | - |
| EU | - |
| Scholarships | - |

START OF THE PROJECT

2011

INFORMATION

V Baukh
040 247 3231
v.v.baukh@tue.nl

PROJECT AIM

The aim of the current project is to understand how compositions of multilayer coatings influence water transport. Different compositions may induce different water-polymer interactions in layers of coatings. As a result, different sorption characteristics and water transport kinetics will be observed. The focus of the study is on the influence of additives in waterborne layers on their sorption and transport properties.

PROGRESS

It was shown that high resolution NMR imaging is a versatile tool for studying such processes. Besides imaging of how water distributes in multilayer coatings during transport, this technique is capable of evaluating water-polymer interactions in individual layers. Furthermore, a theoretical model for water transport in multilayer coatings was developed and verified. The theory shows that water transport is determined by the permeability of the barrier layer to water and the sorption isotherms of a base layer, which is sensitive to water. The following steps are to gain understanding of the layer composition influence on these parameters.

DISSERTATIONS

-

SCIENTIFIC PUBLICATIONS

1. V. Baukh, H.P. Huinink, O.C.G. Adan, L.G.J. van der Ven, Natural versus accelerated weathering: Understanding water kinetics in bilayer coatings, Progress in Organic Coatings, 76(9), 1197-1202 (2013).

OPEN TIME OF GLUE MORTAR

PROJECT AIM

The aim of the project is to understand the parameters that determine the open time of glue mortars. The open time is a crucial parameter for the performance of (glue) mortars for joining material components, such as tiles and bricks. The open time is the time during which tiles can be fixed with a sufficiently good adhesion to the substrate. Exceeding this so-called open time would give a huge reduction in adhesion, because of processes taking place at the surface layer, e.g. drying and hardening. Empirically it is known that the open time has an optimum at specific concentration of specific types of modified cellulose. Obviously, optimizing the adhesive strength plays a central role in product development.

PROGRESS

NMR is used to obtain moisture profile during drying of mortar. Experiments were performed on mortar in presence of different weight percentage of Methylhydroxyethylcellulose (MHEC). We observed a homogeneous drying behavior in mortar without MHEC and a front receding drying with increasing concentration of MHEC. A mathematical model was used to calculate the profiles based on an effective diffusion constant. The diffusion constant incorporates two processes Darcy flow and vapor diffusion. Viscosity change was proven to be the main parameter influencing the drying process. Additionally, the evaporation decreased, which is unexpected since evaporation from cellulose ether solutions is not reduced. We suspect that transport of cellulose ethers creates a film at the surface, that acts as a barrier, which reduces the evaporation of water. We suspect that cellulose ether transport is required to create this film, which was investigated by drying of a model porous system, consisting of glass beads. MRI drying experiments and subsequent Thermo-Gravimetric Analysis (TGA) revealed transport to the surface of the materials.

DISSERTATIONS

-

SCIENTIFIC PUBLICATIONS

-

PROJECT LEADERS

SJF Erich, HP Huinink, OCG Adan

RESEARCH THEME

Complex dynamics of fluids

PARTICIPANTS

APA Faiyas

COOPERATIONS

Materials Innovation Institute (M2i), TNO

FUNDED

| | |
|--------------|-------|
| TNO | |
| University | - |
| FOM | - |
| STW | - |
| NWO Other | - |
| Industry | - |
| TNO | 100 % |
| GTI | - |
| EU | - |
| Scholarships | - |

START OF THE PROJECT

2010

INFORMATION

APA Faiyas,
040 247 4853
a.p.a.faiyas@tue.nl

WATER ASSISTED TRANSPORT OF INHIBITORS FOR CORROSION PROTECTION

PROJECT LEADERS

SJF Erich, HP Huinink

RESEARCH THEME

Complex structures of fluids

PARTICIPANTS

M van Soestbergen

COOPERATIONS

TNO

FUNDED

Materials innovation institute

University -

FOM -

STW -

NWO Other -

Industry 40 %

TNO 60 %

GTI -

EU -

Scholarships -

START OF THE PROJECT

2010

INFORMATION

M van Soestbergen

040 247 3830

m.vansoestbergen@m2i.nl

PROJECT AIM

The aim of this project is to obtain knowledge on the physical and chemical processes that underlie the transport of corrosion inhibitors through organic coatings and their subsequent leaching into an aqueous environment. The in this project obtained knowledge is useful to improve the design methodology of future coating systems.

PROGRESS

We have determined accurate detection methods for the corrosion inhibitors, both in the organic coating system as well as in aqueous solution. These methods are used for leaching and diffusion cell experiments. During the leaching experiments the coatings, in which we incorporated up till 10 w% inhibitor, are exposed to demi-water and the increase in inhibitor concentration in the water phase is monitored. The diffusion cell consist of two compartment separated by a coating film, while the transport of inhibitors is determined from the increase in the compartment that initially contained a zero concentration. All this information is combined in the numerical model that we have developed for the corrosion of aluminum substrates. The work has been finished mid 2013.

DISSERTATIONS

-

SCIENTIFIC PUBLICATIONS

1. M. van Soestbergen, S.J.F. Erich, H.P. Huinink, O.C.G. Adan, Dissolution properties of cerium dibutylphosphate corrosion inhibitors, *Corrosion Engineering Science and Technology*, 48 (3), 234-240 (2013).
2. M. van Soestbergen, S.J.F. Erich, H.P. Huinink, O.C.G. Adan, Inhibition of pH fronts in corrosion cells due to the formation of cerium hydroxide, *Electrochimica Acta*, 110, 491-500 (2013).
3. K. Kamran, M. van Soestbergen, L. Pel, Electrokinetic salt removal from porous building materials using ion exchange membranes, *Transport in porous media*, 96, 221-235 (2013).

SALT CRYSTALLIZATION IN POROUS MATERIALS

PROJECT AIM

The aim of this project is to understand the fundamentals of crystallization in porous media, in connection to damage mechanism. In this project the focus is on NaCl. The objective is to come to better understanding in order to develop new method to prevent salt damage in cultural heritage objects.

PROGRESS

Experiments were done with potassium ferrocyanide ($K_4 [Fe (CN)_6] \cdot 3H_2O$) as crystallization inhibitor by spaying against NaCl damage to see the effect of use in situ. These results show that this inhibitor does work and could be used as such. Experiments were done on the use of effect of inhibitor on the various mixtures of salts, i.e., ternary mixtures of NaCl + KCl + water; NaCl + LiCl + water. These show that the inhibitor can still have an effect on the crystallization. A model has been developed to explain the difference in drying behavior for materials saturated with a NaCl solution. The PhD student finished her work in 2013 and successfully defended her thesis.

DISSERTATIONS

1. S. Gupta, Sodium chloride crystallization in drying porous media: influence of inhibitor, Ph.D. thesis, Eindhoven University of Technology, The Netherlands (2013).

SCIENTIFIC PUBLICATIONS

-

PROJECT LEADERS

K Kopinga, L Pel

RESEARCH THEME

Complex dynamics of fluids

PARTICIPANTS

S Gupta

COOPERATIONS

TNO

FUNDED

STW

University -

FOM -

STW 100 %

NWO Other -

Industry -

TNO -

GTI -

EU -

Scholarships -

START OF THE PROJECT

2009

INFORMATION

L Pel

040 241 9742

l.pel@tue.nl

MEASURING, MODELLING AND MONITORING CHLORIDE INGRESS IN CRACKED CONCRETE

PROJECT LEADERS

OCG Adan, L Pel

RESEARCH THEME

Complex dynamics of fluids

PARTICIPANTS

J Han

COOPERATIONS

TNO, INTRON, BAM

FUNDED

STW

University -

FOM -

STW 100 %

NWO Other -

Industry -

TNO -

GTI -

EU -

Scholarships -

START OF THE PROJECT

2012

INFORMATION

L Pel

040 241 9742

l.pel@tue.nl

PROJECT AIM

The objective of this project is to determine the effect of cracks on the chloride ingress in concrete. This project focuses on the effect of cracks, voids and compaction defects in concrete on chloride transport and on the effect of boundary conditions on the transport processes. The aim is to develop a model which can give a better prediction of the chloride transport over a longer time, i.e., years.

PROGRESS

The objective of this project is to determine the effect of cracks on the chloride ingress in concrete. This project focuses on the effect of cracks, voids and compaction defects in concrete on chloride transport and on the effect of boundary conditions on the transport processes. Some first experiments were done to measure the ion diffusion in porous media. For the first time simultaneously both the Cl and Na distributions in a sample were determined. These measurements have to be extended to samples with cracks. The aim is to use this data to verify a model which can give a better prediction of the chloride transport over a longer time, i.e., years.

DISSERTATIONS

-

SCIENTIFIC PUBLICATIONS

-

PROJECT AIM

The aim of the current project is to understand water transport in multilayer coatings, which consist of hydrophilic base coat and a hydrophobic top coat. The study focuses on investigation of water transport kinetics and its relationship with coating properties. As a key technique high resolution NMR imaging is used, which has a potential for monitoring water distributions during the process and for providing information about water-polymer interactions.

PROGRESS

High resolution NMR imaging has provided water distributions during uptake and has given information about influence of water on coating and state of water in the layers. The observations have enabled to introduce a theoretical model for water transport. The model was experimentally verified and is able to predict water transport. For prediction only two key parameters are needed: the top coat permeability to water and the base coat sorption isotherm. These parameters can be easily measured with low-tech techniques, like gravimetry, enabling the possibility to design simple and cost-efficient test for water transport in such kind of systems.

DISSERTATIONS

1. V. Baukh, Water transport in multilayer coatings, March 5, 2012.

SCIENTIFIC PUBLICATIONS

1. Huinink, H., Baukh, V., Erich, B., Adan, O., Van Der Ven, L., Keeping protection in the clear, (2012) European Coatings Journal, (11), pp. 38-42.

PROJECT LEADERS

OCG Adan, HP Huinink

RESEARCH THEME

Complex dynamics of fluids

PARTICIPANTS

V Baukh

COOPERATIONS

AkzoNobel Automotive & Aerospace Coatings, TNO

FUNDED

| | |
|----------------|------|
| AkzoNobel, TNO | |
| University | - |
| FOM | - |
| STW | - |
| NWO Other | - |
| Industry | 40 % |
| TNO | 60 % |
| GTI | - |
| EU | - |
| Scholarships | - |

START OF THE PROJECT

2007

INFORMATION

V Baukh
040 247 3231
v.v.baukh@tue.nl

PROJECT LEADERS

OCG Adan, L Pel

RESEARCH THEME

Complex dynamics of fluids

PARTICIPANTS

R Pishkari

COOPERATIONS

TNO, NEBEST, Strukton

ENCI, Cosensor

FUNDED

STW

University -

FOM -

STW 100 %

NWO Other -

Industry -

TNO -

GTI -

EU -

Scholarships -

START OF THE PROJECT

2012

INFORMATION

L Pel

040 241 9742

l.pel@tue.nl

PROJECT AIM

The objective of this project is to model the chloride transport at the pore level in concrete, i.e., to describe the transport in the capillary and gel pores. Here fore it is needed to measure the transport of the ions non-destructively and the aim is to develop a NMR setup which will be able to measure nondestructively the transport in concrete.

PROGRESS

The objective of this project is to model the chloride transport at the pore level in concrete, i.e., to describe the transport in the capillary and gel pores. Here fore it is needed to measure the transport of the ions non-destructively and the aim is to develop a NMR setup which will be able to measure nondestructively the transport in concrete. Some first experiments were performed using a 1.5T scanner, which showed the feasibility of the technique for measuring Cl. A new setup is now under development which should operate at 4.7T, giving an improved signal-to-noise ratio.

DISSERTATIONS

-

SCIENTIFIC PUBLICATIONS

-

TGINK (TOWARDS GREEN INK)

PROJECT AIM

Waterborne inks are the future in the area of inkjet printing, since the use of organic solvents has to be reduced for environmental reasons. In an inkjet process droplets are jetted from the nozzle, hit the paper and start to spread, penetrate the paper and evaporate. This all happens on time scales between 0.001 and 1 s. At present water based inks have three main constituents beside water:

1. pigment particles for giving color to the image,
2. polymer particles to create continuous films needed for fixating the pigments and gloss,
3. co-solvent used to prevent evaporation at the tip of nozzle of the inkjet.

Water based inks have much in common with the waterborne coatings.

When ink droplets hit paper the polymeric phase has to form a continuous layer on top of the paper sheet. Since in copiers and printers paper gets a heat treatment after being covered with ink, the actual fusion of the polymeric particles is not a problem. It is the arrangement of particles on the paper before the heat treatment which is the critical factor for obtaining a proper film. Little ingress (order of microns) of the polymeric phase promotes adhesion, but deep penetration prevents the formation of a polymeric layer on top of paper and leads to loss in quality of the image. The penetration depth seems to reduce with increasing evaporation rate and is therefore tightly connected with the addition of the co-solvents mentioned before. For the jetting process itself low evaporation rates are required to prevent blockage of the nozzle and for a good quality of the image high evaporation rates are desired. As this project aims for understanding the penetration of the ink constituents in paper in relation to the evaporation rate of water, the knowledge gained within this project could be used as a tool for improving ink formulations.

PROGRESS

-

DISSERTATIONS

-

SCIENTIFIC PUBLICATIONS

-

PROJECTLEADERS

HP Huinink, OCG Adan

RESEARCHTHEME

Complex dynamics of fluids

PARTICIPANTS

CJ Kuijpers

COOPERATIONS

Materials Innovation Institute (M2i),
Oce

FUNDED

| | |
|--------------|-------|
| M2i, Oce | |
| University | - |
| FOM | - |
| STW | - |
| NWO Other | - |
| Industry | 100 % |
| TNO | - |
| GTI | - |
| EU | - |
| Scholarships | - |

START OF THE PROJECT

2012

INFORMATION

CJ Kuijpers
040 247 4028
c.j.kuijpers@tue.nl

PROJECT LEADERS

OCG Adan, L Pel,

RESEARCH THEME

Complex dynamics of fluids

PARTICIPANTS

PAJ Donkers

COOPERATIONS

Materials Innovation Institute (M2i),

TNO

FUNDED

M2i, TNO

University -

FOM -

STW -

NWO Other -

Industry 100 %

TNO -

GTI -

EU -

Scholarships -

START OF THE PROJECT

2011

INFORMATION

L Pel

040 247 3406

l.pel@tue.nl

PROJECT AIM

Systems that buffer energy are needed to match the demand and supply of renewable energy. These systems should store heat with a high energy density and low or no energy loss. One particular heat storage method with a high potential makes use of the crystallization energy of salts. A drawback of this technique is that by cyclic crystallization-decomposition of the salt systems the efficiency decreases. The aim of this project is to model the combined crystallization-decomposition process and energy transport of salt crystals.

PROGRESS

This year we focussed on the dehydration of $MgSO_4 \cdot 7H_2O$ initiated by temperature. The conventional method of thermo gravimetric techniques to measure the mass loss during dehydration was not sufficient to explain how the water losses from the crystal structure. With help of NMR technique it is possible to measure the state of water in a crystal. We distinguish pore and lattice water. In case of lattice water the water is bounded with hydrogen bonds to the crystal structure, while pore water is not chemically connected with the crystal. We showed that during dehydration pore water appears. The quantity of liquid water depends strongly on the dehydration conditions. It shows us that the dehydration process is a solid-liquid-solid reaction.

DISSERTATIONS

-

SCIENTIFIC PUBLICATIONS

1. P.A.J. Donkers, H.P. Huinink, S.J.F. Erich, N.J.W. Reuvers, O.C.G. Adan, Water permeability of pigmented waterborne coatings, Progress in Organic Coatings, 76(1), 60-69 (2013).



Prof.dr.ir. GMW Kroesen

Our mission is to study the elementary processes in gas discharges by a mix of theory, modelling, and diagnostics.

A thorough understanding of the intensity and effectivity of elementary processes like ionization, recombination, transport, radiation, excitation, de-excitation, chemical reactions and surface processes enables the group to develop predictive models of a large range of plasmas. The understanding is obtained by a strong interleaved integration of state-of-the-art plasma diagnostics with advanced plasma models. Those models then in turn enable users of the plasmas to optimize the plasma source for their specific application. Over the years, the range of applications the group has worked on has shifted continuously: from plasma etching via lighting to medical applications and many other areas. However, the scientific scope of the group has not shifted: continuously the focus has been with the elementary processes in and the physics of plasmas.

PROJECT AIM

The project aims at better understanding ignition of natural and artificial plasmas and gas discharges by means of modeling and numerical simulation. In typical plasma fluid models, the transport of particles is described by a set of drift-diffusion-reaction (DDR) equations. These must be solved together with equations for the flow field, the energy balance equations and equations that govern the production and transport of radiation and the electromagnetic field.

PROGRESS

A novel efficient numerical scheme has been developed for equations of the DDR type, the complete flux scheme (CFS). This takes into account the source terms in the discrete expressions for the flux densities. It has been rigorously shown that the scheme is second-order accurate, even in flows with high-Peclet numbers, where the traditional exponential scheme achieves only first-order grid convergence. The scheme has also been generalized to describe systems of DDR equations, such as those that arise from the Stefan-Maxwell equations that govern diffusion in a flowing multi-component mixture.

DISSERTATIONS

1. Liu, L. (2013). Studies on the discretization of plasma transport equations. Eindhoven: Technische Universiteit Eindhoven. Promotor: prof.dr.ir. G.M.W. Kroesen, co-promotoren: dr.ir. J. van Dijk & dr.ir. J.H.M. ten Thije Boonkamp.

SCIENTIFIC PUBLICATIONS

1. Liu, L., Dijk, J. van, Thije Boonkamp, J.H.M. ten, Mihailova, D.B. & Mullen, J.J.A.M. van der (2013). The Complete Flux Scheme : error analysis and application to plasma simulation. Journal of Computational and Applied Mathematics, 250, 229-243.

PROJECTLEADERS

U Ebert (CWI, TU/e), J van Dijk (TU/e)

RESEARCHTHEME

Mathematical and computational methods for fluid flow analysis

PARTICIPANTS

L Liu, KSC Peerenboom, DB Mihailova, J van Dijk

COOPERATIONS

JHM ten Thije Boonkamp (TU/e)

FUNDED

| | |
|----------------------------------|-------|
| STW, Philips Lighting University | - |
| FOM | - |
| STW | 100 % |
| NWO Other | - |
| Industry | - |
| TNO | - |
| GTI | - |
| EU | - |
| Scholarships | - |

START OF THE PROJECT

2009

INFORMATION

J van Dijk
040 247 4871
j.v.dijk@tue.nl
plasimo.phys.tue.nl

MODELING OF THE COMPRESSIBLE, MAGNETIZED PLASMA FLOW IN MAGNUM-PSI

PROJECT LEADERS

JJAM van der Mullen, WJ Goedheer

RESEARCH THEME

Complex dynamics of fluids

PARTICIPANTS

KSC Peerenboom, J van Dijk,
JJAM van der Mullen, WJ Goedheer.
GMW Kroesen

COOPERATIONS

JHM ten Thije Boonkamp (TU/e)

FUNDED

FOM Institute DIFFER
University -
FOM 100 %
STW -
NWO Other -
Industry -
TNO -
GTI -
EU -
Scholarships -

START OF THE PROJECT

2008

INFORMATION

KSC Peerenboom
040247 5753
k.s.c.peerenboom@tue.nl
plasimo.phys.tue.nl

PROJECT AIM

The aim of the project is to obtain fundamental insight in the magnetized plasma jet of Magnum-PSI, a plasma generator for studying ITER wall materials, by numerical simulations. To achieve this, effort will also be put in the development of numerical methods for solving the system of equations for the transonic flowing, magnetized and non-equilibrium multi-component plasma.

PROGRESS

This project has been concluded by the PhD thesis of K.S.C. Peerenboom (July 2012). Insight in the spatial distribution of the electric field and shockwaves in magnetized plasmas was obtained.

DISSERTATIONS

-

SCIENTIFIC PUBLICATIONS

1. Peerenboom, K.S.C., Dijk, J. van, Goedheer, W.J. & Kroesen, G.M.W., Effects of magnetization on an expanding high-enthalpy plasma jet in argon, Plasma Sources Science and Technology, 22(2):025010, 2013.

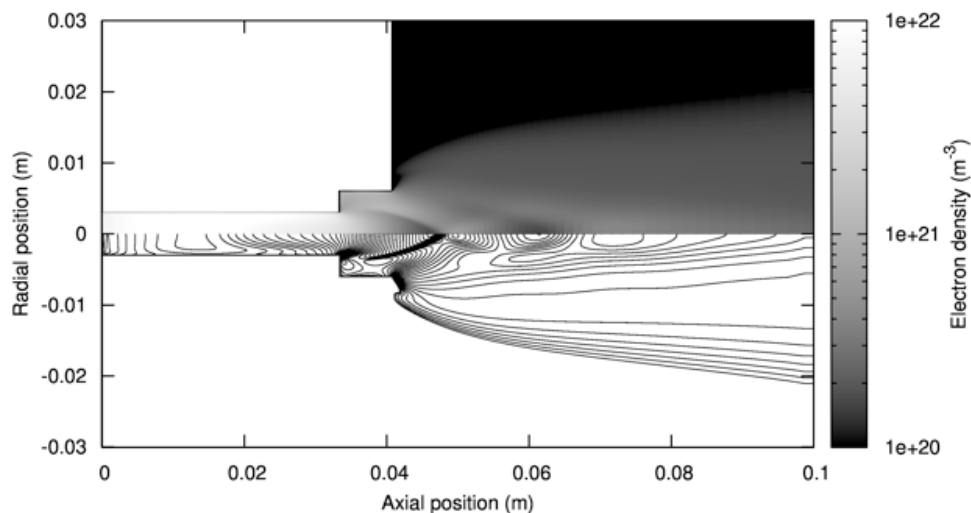

PROJECT AIM

Current HID lamps use mercury as a buffer gas. Mercury is a toxic component and therefore the usage of mercury should be limited in lamps. The research concerns the investigation of the feasibility of alternative buffer species. This part of the project focusses on building a simulation model that can aid in the development of these novel lamps. The model should be good enough to predict the temperature profile and the spectrum. A parameter wise variation of salts should be done to optimize the lamp's efficacy.

PROGRESS

The calculation of the transport coefficients has been improved by using more advanced expressions for the thermal and electrical conductivities. Additionally the methods to estimate the collision integrals have been upgraded. An important effect in HID lamps is radial demixing. To account for this process a program is developed that solves the Stefan-Maxwell equations. These equations are supplemented with conservation rules to adjust the total mass or coldspot pressure. A 1D program is made to account for the relevant processes in the lamp. The results of the model show that it is not possible to replace mercury with salts like InI or SnI because of a strong contribution of quasi-molecular radiation.

DISSERTATIONS

-

SCIENTIFIC PUBLICATIONS

1. J.F.J. Janssen, M. Gnybida, J.L.G. Suijker, A.J. Rijke, and J. van Dijk, On the atomic line profiles in high pressure plasmas. *J. Appl. Phys.* 114,183301, 2013.



PROJECTLEADERS

J van Dijk

RESEARCHTHEME

Complex dynamics of fluids

PARTICIPANTS

J Janssen, M Gnybida,
K Peerenboom, J van Boxtel,
J van Dijk

COOPERATIONS

Jos Suijker (Philips Lighting)
Maxime Gendre (Philips Lighting)

FUNDED

| | |
|--------------------|-------|
| EU (CATRENE CA502) | |
| University | - |
| FOM | - |
| STW | - |
| NWO Other | - |
| Industry | - |
| TNO | - |
| GTI | - |
| EU | 100 % |
| Scholarships | - |

START OF THE PROJECT

2010

INFORMATION

J Janssen
06 486 53991
j.f.j.janssen@tue.nl
www.plasimo.phys.tue.nl

PLASMA SOURCE TECHNOLOGIES FOR PLASMA-BASED EUVL OPTICS CLEANING

PROJECT LEADERS

GMW Kroesen, S Nijdam, J Beckers

RESEARCH THEME

Complex dynamics of fluids

PARTICIPANTS

FMJH van de Wetering

COOPERATIONS

ASML

FUNDED

STW (NanoNext)

University -

FOM -

STW 100 %

NWO Other -

Industry -

TNO -

GTI -

EU -

Scholarships -

START OF THE PROJECT

2013

INFORMATION

S Nijdam

040 247 4342

s.nijdam@tue.nl

www.tue.nl/staff/s.nijdam

PROJECT AIM

New plasma and plasma source technologies will be explored that have the potential to tackle simultaneously the two fundamental problems mentioned in the twinning research projects on EUVL: dust particles and surface contamination. The sources are targeted to be designed such that the plasmas trap debris particles, charge them negatively, and transport them to a desired place in the system. Simultaneously, the plasma is used to etch away the contamination. EMC and emission of radiation, ions, electrons and radicals are targeted to be fully controlled.

PROGRESS

A lab setup is used to produce nanoparticles (10s – 100s nm) within a low-pressure plasma using acetylene (C₂H₂) as the precursor gas. The growing particles will influence the plasma dynamics. Diagnostics have been developed to track important (plasma) parameters, such as microwave cavity resonance spectroscopy to follow the free-electron density. The distribution of the dust particles within the discharge volume is tracked using laser light scattering. The plasma emission is also recorded. Due to the charging of the particles they exhibit collective behavior. One observation was the development of a so-called dust void: a macroscopic region of the plasma devoid of dust particles. Peculiar dynamics of the dust void were observed. We were able to explain the phenomenon at a fundamental level with the help of said diagnostics.

DISSERTATIONS

-

SCIENTIFIC PUBLICATIONS

1. (Oral presentation) F.M.J.H. van de Wetering, S. Nijdam, J. Beckers & G.M.W. Kroesen (2013). Void dynamics in low-pressure acetylene RF plasmas. In Proceedings of the 66th Annual Gaseous Electronics Conference (GEC), September 30 - October 4, 2013, Princeton, New Jersey Vol. 58. Bulletin of the American Physical Society.
2. (Oral presentation) F.M.J.H. van de Wetering, R.J.C. Brooimans, S. Nijdam, J. Beckers & G.M.W. Kroesen (2013). Void dynamics in low-pressure acetylene RF plasmas. In Proceedings of the 16th Workshop on the Exploration of Low Temperature Plasma Physics (WELTPP-16 2013), 21-22 November 2013, Kerkrade, the Netherlands.
3. (Poster presentation) R.J.C. Brooimans, F.M.J.H. van de Wetering, S. Nijdam, J. Beckers & G.M.W. Kroesen (2013). Spatiotemporal characterization of dust-forming acetylene RF plasmas. In Proceedings of the 16th Workshop on the Exploration of Low Temperature Plasma Physics (WELTPP-16 2013), 21-22 November 2013, Kerkrade, the Netherlands.
4. (Poster presentation) F.M.J.H. van de Wetering, S. Nijdam, J. Beckers & G.M.W. Kroesen (2013). The electron density and transmission electron microscopy of dust-forming acetylene plasmas. In Proceedings of the 25th NNV-Symposium on Plasma Physics & Radiation Technology, 5-6 March 2013, Lunteren, the Netherlands.

STICK TO THE SURFACE

PROJECT AIM

In EUV lithography tools free floating particles are a cause for concern as they can land on the reticle (mask) where they should be avoided at any cost. However, on any surface inside such a machine there will be dust particles present which can be released by flow and/or plasma conditions. We want to study when and how particles are released from surfaces by (interaction of) flow and plasma under the conditions present in an Extreme-Ultraviolet (EUV) lithography tool and how plasma conditions can directly damage (collector) mirror surfaces in such a tool.

PROGRESS

A test setup is built in which either an RF plasma or a DC electric field can be applied between two electrodes. Using a dust dispenser dust particles (spherical 10 μm diameter) can be dropped on the bottom electrode. Fluorescent particles are used to ease imaging, as this has proven to be difficult, due to reflections from the electrode surface. Exploratory measurements have not yet resulted in particle removal by a plasma or an electric field. Plans are made to apply an extra known force to the particles to measure (and influence) the adhesive force. Vibration by a piezo actuator is the main researched option.

DISSERTATIONS

-

SCIENTIFIC PUBLICATIONS

1. Heijmans, L.C.J., Beckers, J., Nijdam, S. & Kroesen, G.M.W. (2013). Particles on a surface under influence of a plasma. Proceedings of the 16th Euregional Workshop on the Exploration of Low Temperature Plasma Physics (WELTPP-16 2012), 21-22 November 2013, Kerkrade, The Netherlands.
2. Heijmans, L.C.J., Beckers, J., Nijdam, S. & Kroesen, G.M.W. (2013). Particle release from surface by plasma. Proceedings of the 18th European Summer School "Low Temperature Plasma Physics: Basics and Applications", 5-10 October 2013, Bochum, Germany.

PROJECTLEADERS

S Nijdam, J van Dijk, GMW Kroesen

RESEARCHTHEME

Complex structures of fluids

PARTICIPANTS

LCJ Heijmans

COOPERATIONS

Together with WDY-group, TU/e. F. Toschi and H.J.H. Clercx with PhD student

FUNDED

| | |
|--------------|------|
| STW, ASML | |
| University | - |
| FOM | - |
| STW | 62 % |
| NWO Other | - |
| Industry | 38 % |
| TNO | - |
| GTI | - |
| EU | - |
| Scholarships | - |

START OF THE PROJECT

2013

INFORMATION

S Nijdam
040 247 4342
s.nijdam@tue.nl
www.tue.nl/staff/s.nijdam



Prof.dr. LPH de Goey



Prof.dr. B Johansson

The goal of the research programme of the 'Combustion Technology Group' is to gain insight in and knowledge on reacting flows in order to develop new and improve existing models of combustion systems. The models are used to guide new developments in the struggle to come to more efficient and clean conversion systems of fossil and sustainable fuels for a sustainable society. The knowledge and models developed are based on thorough physical and chemical understanding of the processes. This means that the gap between fundament and application has to be bridged continuously by transforming models describing physical/chemical behaviour on the smallest scales to models for the macroscopic scale of the full system. The knowledge is based on 'generic' theoretical and numerical insights for the propagation and structure of idealised flames and their interaction with acoustic waves, turbulent structures and inert/reacting surfaces. Most models for the combustion chemistry are based on a combination of the so-called laminar flamelet concept and chemical reduction methods leading to new techniques like FGM.

There is also a close entanglement of theoretical/numerical and experimental research. Available diagnostic techniques are e.g. flame visualisation, absorption techniques, LDV, PIV, LIF and Rayleigh scattering. Validation with the available laser-diagnostic measurement systems in the laboratory and real applications is carried out to disentangle the processes taking place on the various length and time scales. These measurements are carried out in flat (non-)adiabatic flames stabilised on the Heat Flux burner, laminar flames on Bunsen-type burners, flat turbulent flames on a weak-swirl burner, biomass grid, tube and bed reactors, optically-accessible combustion vessels and optically-accessible engines. Application areas are: small-scale laminar combustion systems, combustion of bio-fuels, engines and gas turbines. The application area of combustion engines is of particular interest.

SUPPRESSION OF THERMO-ACOUSTIC INSTABILITIES IN CENTRAL HEATING EQUIPMENT BY BURNER DESIGN OPTIMIZATION

PROJECT AIM

The aim of this project is to provide tools to suppress the thermo-acoustic instabilities by optimizing the design of the perforated burners. Within the scope of this project different methods (experimental as well as numerical) will be explored for a-priori calculation of acoustic response (the flame transfer function) of the perforated burners. This information of transfer function is then used for (in)stability prediction of a simplified boiler using acoustic network model approach.

PROGRESS

The acoustic response of the perforated burner plate is calculated using FLUENT®. An excellent match between numerically and experimentally obtained transfer function is obtained. The correct chemical mechanism and burner deck temperature are the key elements to obtaining the TF numerically. The parameterization of the transfer function of perforated burner deck will be done in near future and will be submitted to the European combustion meeting.

DISSERTATIONS

-

SCIENTIFIC PUBLICATIONS

1. Hoeijmakers, P.G.M., Lopez Arteaga, I., Kornilov, V.N., Goeij, L.P.H. de & Nijmeijer, H. (2013). Accuracy assessment of thermoacoustic instability models using binary classification. *International Journal of Spray and Combustion Dynamics*, 5(3), 201-224.
2. Hoeijmakers, P.G.M., Lopez Arteaga, I., Kornilov, V.N., Nijmeijer, H. & Goeij, L.P.H. de (2013). Experimental investigation of intrinsic flame stability. In *Proceedings of the 6th European Combustion Meeting*.

PROJECTLEADERS

I Lopez, V Kornilov, H Nijmeijer, LPH de Goeij

RESEARCHTHEME

Complex dynamics of fluids

PARTICIPANTS

Manohar M, PGM Hoeijmakers, V Kornilov, I Lopez, H Nijmeijer, LPH de Goeij

COOPERATIONS

STW, Bekaert, Honeywell, ATAG, Remeha

FUNDED

| | |
|--------------|------|
| STW | |
| University | - |
| FOM | - |
| STW | 75 % |
| NWO Other | - |
| Industry | 25 % |
| TNO | - |
| GTI | - |
| EU | - |
| Scholarships | - |

START OF THE PROJECT

2011

INFORMATION

Manohar
040 247 3819
manohar@tue.nl
www.tue.nl/combustion

PROJECT LEADERS

JA van Oijen, LPH de Goey

RESEARCH THEME

Complex dynamics of fluids

PARTICIPANTS

SE Abtahizadeh

COOPERATIONS

University of Groningen, TATA Steel, NUMECA

FUNDED

STW, NNV, TATA Steel, NUMECA

University -

FOM -

STW 72 %

NWO Other -

Industry 28 %

TNO -

GTI -

EU -

Scholarships -

START OF THE PROJECT

2010

INFORMATION

JA van Oijen

040 247 3133

j.a.v.oijen@tue.nl

www.tue.nl/combustion

PROJECT AIM

In this project, MILD combustion by using highly preheated and diluted oxidizer and/or fuel streams will be studied to provide lower peak temperatures and as a result, low NOx emissions. Towards this end, 1D simulations of counterflow diffusion flames will be done to study the consequences of the composition of the fuel and/or oxidizer on spatial flame structure. Two-dimensional simulations of a coflow burner will be performed to compare with measurements. Based on the computational results obtained, a reduced chemical model for MILD combustion will then be developed and implemented in codes for simulation of turbulent combustion in JHC burners.

PROGRESS

Numerical investigations have been performed to understand preferential diffusion effects in the lift-off height and stabilization mechanism of turbulent lifted CH4/H2 flames in a hot and diluted environment. A combined LES and FGM-PDF model is developed to simulate the Delft JHC burner. A novel Flamelet Generated Manifolds (FGM) based model is developed to handle detailed chemistry in these computations. Predictions of the velocity field are compared with measurements of velocity indicating a very good agreement. Computations of the reacting field reveal that the enrichment of fuel with hydrogen leads to a significant change in the lift-off height and stabilization mechanism of the lifted turbulent flames. Main features of these lifted turbulent flames such as the formation of ignition kernels and stabilization mechanisms are analyzed.

DISSERTATIONS

-

SCIENTIFIC PUBLICATIONS

1. S.E. Abtahizadeh, A. Sepman, J.A. van Oijen, A. Mokhov, L.P.H. de Goey, H. Levinsky, Numerical and experimental investigations on the influence of preheating and dilution on transition of laminar coflow diffusion flames to Mild combustion regime, *Combustion and Flame*, 160 (2013) 2359-2374.
2. Sepman, S.E. Abtahizadeh, A. Mokhov, J.A. van Oijen, H. Levinsky, L.P.H. de Goey, Numerical and experimental studies of the NO formation in laminar coflow diffusion flames on their transition to Mild combustion regime, *Combustion and Flame*, 160 (2013) 1364-1372.
3. Sepman, S.E. Abtahizadeh, A. Mokhov, J.A. van Oijen, H. Levinsky, L.P.H. de Goey, Experimental and numerical studies of the effects of hydrogen addition on the structure of a laminar methane-nitrogen Jet in Hot Coflow under Mild Conditions, *International Journal of Hydrogen Energy*, 38 (2013), 13802-13811.

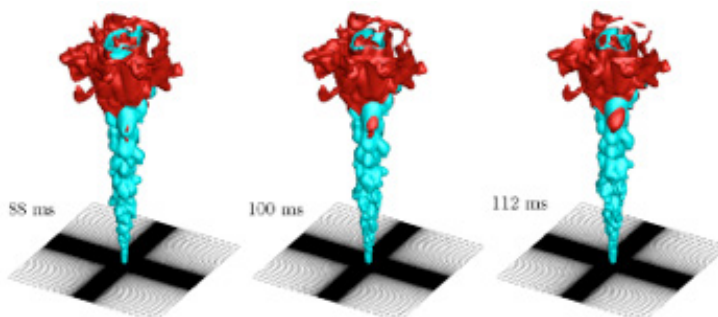

PROJECT AIM

The focus of this project is on MILD combustion, which is characterized by a high degree of preheating and dilution of the reactants and offers the possibility of a sustainable, emission-free energy production. The project encompasses a multi-scale approach that starts with an exploration of the small-scale fundamental processes causing the outstanding properties of MILD combustion. This fundamental knowledge is then translated via numerical studies of lab-scale burners into design tools for large-scale industrial combustion devices. To investigate the reaction structures that arise in MILD combustion, high-fidelity numerical models will be employed.

PROGRESS

DNS of jet in hot coflow (JHC) burner of Adelaide has been conducted in the form of auto-igniting mixing layers. 2D and 3D simulations with nominal and actual temperature profiles are performed to observe the differences in turbulent mixing. It is seen that the inclusion of heat loss effects, delays the ignition considerably. Furthermore, in 3D, vortex stretching delays the ignition and enhances local mixing. LES of the Delft Jet-in-Hot-Coflow (DJHC-I), with FGM based on counter-flow diffusion flames have been performed. The predicted lift-off height and mean resolved axial velocities displayed an overall good agreement with measurements. The temperature field was overpredicted at a height of 90 mm and above. Improvements in the modelling, accounting for the non-uniform coflow conditions, are underway.

DISSERTATIONS

-

SCIENTIFIC PUBLICATIONS

1. F.E. Hernandez Perez, J.A. van Oijen, L.P.H. de Goeij, LES of MILD Combustion: Delft Jet-in-Hot-Coflow Flame, 14th International Conference on Numerical Combustion, San Antonio TX, April 2013.
2. M.U. Göktolga, J.A. van Oijen, L.P.H. de Goeij, Direct Numerical Simulation of MILD Combustion for Different Dilution Levels and Fuel Compositions, ECM 2013, Lund, June 2013.
3. F.E. Hernandez-Perez, J.A. van Oijen, L.P.H. de Goeij, Computational study on the stability of lean CH₄-air and H₂-CH₄-air laminar premixed flames, ECM 2013, Lund, June 2013.
4. J.A. van Oijen, M.U. Göktolga, L.P.H. de Goeij, Low-dimensional manifolds in direct numerical simulations of autoigniting mixing layers. Proceedings of the Fourth International Workshop on Model Reduction in Reacting Flows, June 2013, San Francisco, California, (pp. 1-2).

PROJECT LEADERS

JA van Oijen

RESEARCH THEME

Complex dynamics of fluids

PARTICIPANTS

FE Hernandez Perez, MU Göktolga,
A Vasavan, JA van Oijen

COOPERATIONS

-

FUNDED

| | |
|--------------|-------|
| NWO (VIDI) | |
| University | - |
| FOM | - |
| STW | - |
| NWO Other | 100 % |
| Industry | - |
| TNO | - |
| GTI | - |
| EU | - |
| Scholarships | - |

START OF THE PROJECT

2010

INFORMATION

JA van Oijen

040 247 3133

j.a.v.oijen@tue.nl

www.tue.nl/combustion

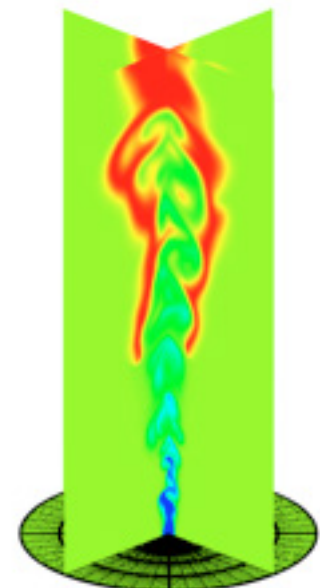

CFD MODELING FOR THE OPTIMIZATION OF A FLAME IONIZATION SENSOR

PROJECT LEADERS

JA van Oijen, LPH de Goeij

RESEARCH THEME

Complex dynamics of fluids

PARTICIPANTS

N Speelman

COOPERATIONS

Bosch Thermotechnik

FUNDED

Bosch Thermotechnik

University -

FOM -

STW -

NWO Other -

Industry 100 %

TNO -

GTI -

EU -

Scholarships -

START OF THE PROJECT

2010

INFORMATION

JA van Oijen

040 247 3133

j.a.v.oijen@tue.nl

www.tue.nl/combustion

PROJECT AIM

The purpose of this research is to develop a combustion control and diagnostics sensor based on flame ionization for condensing boiler applications. The flame ionization sensor measures the electrical conduction of the charged species generated during the combustion process to detect flashback and combustion instabilities, and to monitor equivalence ratio. In particular, the focus is on developing models to integrate the electric field emanating from the electrode with the lean premixed combustion process and ion reaction/transport submodels to simulate the electrode test results and optimize its position and shape.

PROGRESS

The project was started in October 2010 and since then literature in the field of combustion in the presence of electrical fields has been studied. The electrical potential calculation has been incorporated into the existing one-dimensional flame code through Poisson's equation together with models for electrically charged species. The calculation of the electric current has been implemented and is currently being used to investigate the electric saturation region, diode effect and the influence of chemical mechanisms. Work is underway to simulate AC currents as well. Furthermore, a basic implementation of a flamelet-based chemistry model (FGM) in the commercial solver used by Bosch Thermotechnik has been realized and the theoretical work has been done to extent this with charged species.

DISSERTATIONS

-

SCIENTIFIC PUBLICATIONS

1. Speelman, N., Oijen, J.A. van & Goeij, L.P.H. de (2013). Development of a flame ionization model for the prediction of electric currents in methane-air flames. Proceedings of the European Combustion Meeting 2013 (ECM), 25-28 June 2013, Lund, Sweden, (pp. P2-84).

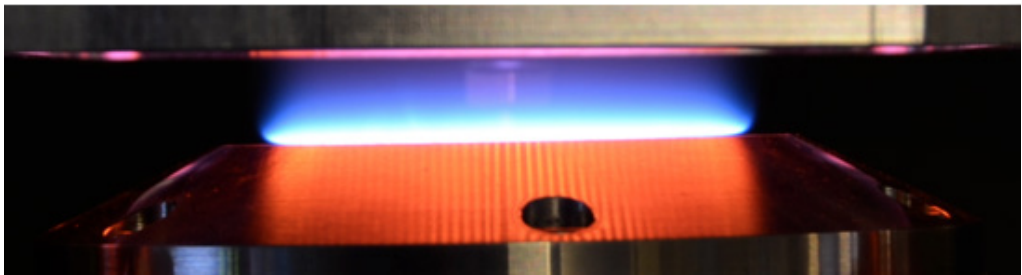

WORLD'S ACCURATE FLAME STRETCH THEORY

PROJECT AIM

In a premixed flame, due to the flow straining, burner geometry etc, the flame speed, and structure gets affected, and this effect is called flame stretch. Modeling and predicting flame stretch plays an important role for knowing the flame characteristics. In this project, the main aim, is to understand the various nuances of flame stretch, including its origin and to model it for a laminar flame.

PROGRESS

In a premixed flame, due to the flow straining, burner geometry etc, the flame speed, and structure gets affected, and this effect is called flame stretch. Modeling and predicting flame stretch plays an important role for knowing the flame characteristics. In this project, the main aim, is to understand the various nuances of flame stretch, including its origin and to model it for a laminar flame.

DISSERTATIONS

-

SCIENTIFIC PUBLICATIONS

-

PROJECT LEADERS

LPH de Goey

RESEARCH THEME

Mathematical and computational methods for fluid flow analysis

PARTICIPANTS

AG Iyer, JA van Oijen, JHM ten Thije
Boonkkamp

COOPERATIONS

-

FUNDED

| | |
|--------------|-------|
| STW | - |
| University | - |
| FOM | - |
| STW | 100 % |
| NWO Other | - |
| Industry | - |
| TNO | - |
| GTI | - |
| EU | - |
| Scholarships | - |

START OF THE PROJECT

2011

INFORMATION

A Iyer
06 31177799
a.g.iyer@tue.nl

LAMINAR BURNING VELOCITY MEASUREMENTS AND CHEMICAL REACTION MECHANISM EVALUATION OF H₂ RICH SYNGAS AT ELEVATED PRESSURES

PROJECT LEADERS

RJM Bastiaans

RESEARCH THEME

Complex structures of fluids

PARTICIPANTS

M Goswami, AA Konnov,

RJM Bastiaans, LPH de Goeij

COOPERATIONS

H2-IGCC Consortium

FUNDED

EU-FP7 project

University -

FOM -

STW -

NWO Other -

Industry -

TNO -

GTI -

EU 100 %

Scholarships -

START OF THE PROJECT

2010

INFORMATION

Mi Goswami

M.Goswami@tue.nl

www.tue.nl/combustion

PROJECT AIM

The project aims to evaluate flame speed (laminar) of syngas-air mixtures with high H₂ content at conditions of high pressure (30 bars) and temperature (200 °C) that are relevant for gas turbine applications. The heat flux burner will be used in the project. Based on results derived from these experiments a chemical reaction mechanism will be evaluated.

PROGRESS

1. Laminar burning velocity measurements of pressure up to 9 atm with syngas mixtures (50:50% and 85:15% H₂:CO) with a variety of oxidizers at lean conditions using heat flux method.

2. A high pressure setup has been setup in the laboratory for measurements up to 30 bar (conditions relevant for gas turbine applications). The system has been tested with a flame up to 5 atm.

3. Heat flux method was studied with thermophosphors to measure burner plate temperature by replacing thermocouples. The spectral ratio method was applied to relate intensity to temperature.

DISSERTATIONS

-

SCIENTIFIC PUBLICATIONS

1. M. Goswami, S. Derks, K. Coumans, W.J. Slikker, M.H. de Andrade Oliveira, R.J.M Bastiaans, A.A. Konnov and L.P.H. de Goeij. The effect of elevated pressures on the laminar burning velocity of methane+air mixtures. *Combustion and Flame* 160 (2013) 1627-1635.
2. M. Goswami, R.J.M. Bastiaans, L.P.H. de Goeij and A.A. Konnov. Laminar burning velocity of lean H₂-CO mixtures at elevated pressure using the heat flux method. 24th International colloquium on dynamics of explosions and reactive systems (ICDERS), Taipei, Taiwan, 28 July - 2 August, 2013.
3. M. Goswami, K. Coumans, R.J.M. Bastiaans, L.P.H. de Goeij and A.A. Konnov. Numerical simulations of flat laminar premixed CH₄/air flames at elevated pressure. 24th International colloquium on dynamics of explosions and reactive systems (ICDERS), Taipei, Taiwan, 28 July - 2 August, 2013.
4. M. Goswami, M. Wustmans, N.J. Dam, A.A. Konnov, R.J.M. Bastiaans and L.P.H. de Goeij. Temperature measurement for the heat flux method using ZnO:Zn thermophosphor. 6th European Combustion Meeting, Lund, Sweden, June 2013.

NUMERICAL SIMULATION USING FLAMELET GENERATED MANIFOLD TECHNIQUE ON HYDROGEN COMBUSTION FOR GAS TURBINES

PROJECT AIM

The H2-IGCC project, co-funded by the European Union's 7th Framework Programme for Research And Development, is based on the initiative outlined in the European Turbine Network's (ETN). The subproject regarding TU Eindhoven is divided in two parts: Numerical (I) and Experimental (II). My tasks will cover the Numerical part: Development of RANS and LES models will be based on Flamelet Generated Manifold (FGM) techniques with a special focus on preferential diffusion effects, partial unpremixedness and local extinction. These effects govern thermodiffusive instabilities which interact with turbulence in a complicated way. The Simulations will be done with the use of the open source software Open FOAM.

PROGRESS

- ♦ Extension of Flamelet Generated Manifold technique on Open FOAM to higher dimensions (3D) for relatively simple gases.
- ♦ Work in progress is now on the:
- ♦ Addition of hydrogen effects in the mixture and investigation of DNS data from Berkeley National Laboratory . PhD thesis will be completed in May 2014.

DISSERTATIONS

-

SCIENTIFIC PUBLICATIONS

1. Fancello A., Bastiaans R.J.M. and de Goey L.P.H., Numerical simulation of turbulent hydrogen combustion based on flamelet generated manifolds with openfoam. , Proceedings of the 14th International Conference on Numerical Combustion, 8-10 April 2013, San Antonio, Texas, USA, SIAM.
2. Fancello A., Bastiaans R.J.M. and de Goey L.P.H., Towards numerical simulation of turbulent hydrogen combustion based on flamelet generated manifolds, Proceedings of the 8th International OpenFOAM Workshop, 11-14 June 2013, Jeju (South Korea), 2013.
3. Fancello A., Bastiaans R.J.M. and de Goey L.P.H., Towards numerical simulation of turbulent hydrogen combustion in OpenFOAM, 1558, 168 (2013); doi: 10.1063/1.4825447.

PROJECT LEADERS

RJM Bastiaans

RESEARCH THEME

Mathematical and computational methods for fluid flow analysis

PARTICIPANTS

A Fancello, RJM Bastiaans, LPH de Goey

COOPERATIONS

H2-IGCC Consortium
Siemens AG

FUNDED

EU-FP7 project
University -
FOM -
STW -
NWO Other -
Industry -
TNO -
GTI -
EU 100 %
Scholarships -

START OF THE PROJECT

2010

INFORMATION

A Fancello
040 247 3621
a.fancello@tue.nl
www.tue.nl/combustion

PROJECT LEADERS

RJM Bastiaans, LPH de Goey,
BJ Geurts

RESEARCH THEME

Complex dynamics of fluids

PARTICIPANTS

Thiago Cardoso de Souza

COOPERATIONS

U Twente, Ansaldo-Thomassen

FUNDED

| | |
|--------------|-------|
| STW | |
| University | - |
| FOM | - |
| STW | 100 % |
| NWO Other | - |
| Industry | - |
| TNO | - |
| GTI | - |
| EU | - |
| Scholarships | - |

START OF THE PROJECT

2009

INFORMATION

Thiago Cardoso de Souza
040 247 3731
t.cardoso.de.souza@tue.nl
www.tue.nl/combustion

PROJECT AIM

Considering the range of turbulent scales that occur in situations involving turbulent premixed combustion and the interaction of these scales with the flame front, the goal of this project is to investigate the response of a flame front embedded in a turbulent flow where certain conditions referred as 'resonant turbulence' are occurring. It is expected that an increase on the flame surface density can be achieved when the flow is subject to these 'resonant' conditions.

PROGRESS

Currently, DNS simulations of resonant turbulence in premixed combustion are currently investigated considering a Bunsen flame subject to these forcing conditions. For such simulations, we use our in-house CFD code, which was also already applied in other situations associated with premixed combustion. The forcing is introduced at the inflow plane of our numerical grid using sinusoidal modes related with a given wave number and amplitude, then we characterize the flame response to these resonant flow by looking into the conversion rate and the effects of the turbulent scales in the flame structure, considering a situation with and without such flow perturbations.

DISSERTATIONS

-

SCIENTIFIC PUBLICATIONS

1. Cardoso de Souza, T., Bastiaans, R.J.M., Geurts, B.J., de Goey, L.P.H. (2013). Steady large-scale modulation of a moderately turbulent co-flow jet, Accepted for publication in Journal of Turbulence.
2. Cardoso de Souza, T., Bastiaans, R.J.M., Geurts, B.J., de Goey, L.P.H. (2013). Space-time modulation of turbulence in co-flow jets, in preparation for publication in Physics of Fluids.
3. Cardoso de Souza, T., Bastiaans, R.J.M., Geurts, B.J., de Goey, L.P.H. (2013). Space-time turbulence modulation for premixed flames, in preparation for publication in Flow, Turbulence and Combustion.

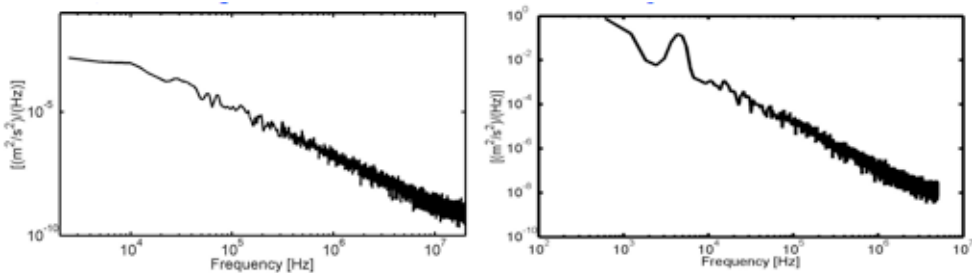

Turbulent Kinetic energy spectrum: Left: spectrum obtained using random perturbations applied at the inflow plane to generate turbulence in the DNS simulations of the Bunsen flame. Right: Sinusoidal modes related with a certain length scale introduced jointly with the inflow random algorithm used to generate turbulence.

PROJECT AIM

The aim of this project is to study the fluid and combustion in micro gas turbine to reduce NOx emission, improve combustion status and increase efficiency. Optimal injection location will be found to make air and gas mixed well and lean combustion in small scale combustor will be developed.

PROGRESS

Simulations of the cold flow in micro gas turbine have been performed with realizable k-epsilon model and species transport model. Two different models with different injection holes are used and show different flow fields in chambers. The result show a big difference between these two types of injection holes. The detailed influence of this is still need to solve. The mixing situation could affect selection of combustion model and also the NOx emission which is needed to be investigate. Also, a simple simulation of 2D cylindrical combustor has been researching with the objective of how to select combustion model and the difference between them.

DISSERTATIONS

-

SCIENTIFIC PUBLICATIONS

1. Yuchun Zhao, R.J.M. Bastiaans, V.N. Kornilov, L.P.H. de Goey - Cold Flow CFD Simulation of Micro Turbine – ECM 2013 – Lund, Sweden- June, 2013.

PROJECTLEADERS

RJM Bastiaans, LPH de Goey

RESEARCHTHEME

Complex dynamics of fluids

PARTICIPANTS

Y Zhao, V Kornilov, RJM Bastiaans,
LPH de Goey

COOPERATIONS

-

FUNDED

China Scholarship Council (CSC)
University -
FOM -
STW -
NWO Other -
Industry -
TNO -
GTI -
EU -
Scholarships 100 %

START OF THE PROJECT

2012

INFORMATION

Y Zhao
040 247 2877
Y.Zhao1@tue.nl
www.tue.nl/combustion

CROSSING THE COMBUSTION MODES IN DIESEL ENGINES (XCiDE)

PROJECT LEADERS

LPH de Goey, LMT Somers, NJ Dam

RESEARCH THEME

Mathematical and computational methods for fluid flow analysis

PARTICIPANTS

U Egüz, CAJ Leermakers

COOPERATIONS

DAF

FUNDED

STW, DAF, Delphi, Shell, Avantium

University -

FOM -

STW -

NWO Other 70 %

Industry 30 %

TNO -

GTI -

EU -

Scholarships -

START OF THE PROJECT

2009

INFORMATION

U Egüz

040 247 3286

u.eguz@tue.nl

CAJ Leermakers

040 247 2393

c.a.j.leermakers@tue.nl

www.tue.nl/combustion

PROJECT AIM

The development of a well-established understanding of the processes occurring in the cylinder in different combustion regimes will be indispensable since new combustion concepts make diesel engines much more complex. The project aims to gain a better understanding of the new combustion concepts and develop numerical models that capture the complex combustion phenomena in these concepts. For the latter the FGM approach will be extended and applied in a CFD approach. To validate the models and even more to increase the fundamental knowledge of the new combustion concepts, high speed laser diagnostic techniques are developed.

PROGRESS

The FGM approach is implemented on an engine setup to model conventional and low temperature diesel combustion. The database for chemistry generation is created by homogeneous reactors and igniting counter-flow diffusion flamelets. The method is validated by comparing pressure trace and ignition delay results with the experimental data. Various alternative combustion concepts have been investigated using experimental tests, as well as a variety of fuels (or fuel combinations) to use in either conventional or these alternative combustion concepts. Both high speed, and statistically correlated laser diagnostic techniques have been developed and an attempt has been made to apply these techniques to both conventional and advanced combustion regimes, to gain the further understanding and fundamental knowledge.

DISSERTATIONS

1. Egüz, U. (2013). Crossing the combustion modes in diesel engines. Eindhoven: Technische Universiteit Eindhoven. ((Co-) promot.: prof.dr. L.P.H. de Goey & dr.ir. L.M.T. Somers).

SCIENTIFIC PUBLICATIONS

1. Egüz, U., Ayyapureddi, S., Bekdemir, C., Somers, L.M.T. & Goey, L.P.H. de (2013). Manifold resolution study of the FGM method for an igniting diesel spray. *Fuel*, 113, 228-238.
2. Egüz, U., Maes, N.C.J., Leermakers, C.A.J., Somers, L.M.T. & Goey, L.P.H. de (2013). Predicting auto-ignition characteristics of RCCI combustion using a multi-zone model. *International Journal of Automotive Technology*, 14(5), 693-699.
3. Egüz, U., Leermakers, C.A.J., Somers, L.M.T. & Goey, L.P.H. de (2013). Premixed charge compression ignition combustion modeling with a multi-zone approach including inter-zonal mixing. *Proceedings of the Institution of Mechanical Engineers, Part D: Journal of Automobile Engineering*, 227(9), 1313-1324.
4. Leermakers, C.A.J., Luijten, C.C.M., Somers, L.M.T., Goey, L.P.H. de & Albrecht, B.A. (2013). Experimental study on the impact of operating conditions on PCCI combustion. *International Journal of Vehicle Design*, 62(1), 1-20.
5. Leermakers, C.A.J., Bakker, P.C., Somers, L.M.T., Goey, L.P.H. de & Johansson, B.H. (2013). Commercial Naphtha blends for partially premixed combustion. *SAE International Journal of Fuels and Lubricants*, 6(1):2013-01-1681.
6. Leermakers, C.A.J., Bakker, P.C., Somers, L.M.T., Goey, L.P.H. de & Johansson, B.H. (2013). Butanol-diesel blends for partially premixed combustion. *SAE International Journal of Fuels and Lubricants*, 6(1):2013-01-1683.

7. Nijssen, B.C.W. (2013). Experimental study on Partially Premixed Combustion : ON70 fuel composition effects', WVT, No. 2013.05), 92 pp.

EMISSION REDUCTION IN COMPRESSION-IGNITION ENGINES BY FUEL TUNING

PROJECT LEADERS

LPH de Goey, NJ Dam, MD Boot

RESEARCH THEME

Complex dynamics of fluids

PARTICIPANTS

L Zhou

COOPERATIONS

Technical University of Munich,
Damark Technical University

FUNDED

TU/e, European Graduate School on
Sustainable Energy

University 100 %

FOM -

STW -

NWO Other -

Industry -

TNO -

GTI -

EU -

Scholarships -

START OF THE PROJECT

2009

INFORMATION

L Zhou

040 247 5995

L.Zhou@tue.nl

www.tue.nl/combustion

PROJECT AIM

In order to adopt appropriate bio-fuels as alternatives of diesel for lower soot emission, this project is focused on the exploration of the mechanisms of soot formation by using advanced measurement methods by combining fundamental investigation and application research. The fundamental research is accomplished by a special designed High Pressure Vessel and Burner (HPVB) with an optical accessibility for laser diagnostic techniques. It provides capabilities of burning vaporized liquid fuels in laminar diffusion flames and research focuses on the impact of fuel molecular structures on the sooting tendencies of relevant fuels and bio-fuels. Besides, the HPVB setup is designed to allow measurements at elevated pressures. For the prospective of applications of relevant fuels in compression ignition engines, the research is focused on the effect of molecular structures on the soot-NOx emissions trade-off and corresponding engine performance. This is realized by means of experiments on a modified DAF heavy-duty diesel engine.

PROGRESS

Soot volume fraction measurements in laminar diffusion flames of n-heptane from atmospheric to elevated pressure by Laser Induced Incandescence (LII) and Line-Of-Sight Attenuation (LOSA) have been finalized. Moreover, fuels with two kinds of molecular structures, straight line and cyclic, have been studied and the sooting tendencies of laminar diffusion flames of these fuels blended in n-heptane at elevated pressure have been measured. In addition, the effect of the molecular structure of the bio-fuels on emission performance in a heavy-duty diesel engine, where the same group of the fuels which was studied in HPVB has been used. Then, as an extended research on bio-fuels from 2nd generation biomass, three lignin-derived aromatic oxygenates, including anisole, benzyl alcohol and 2-phenyl ethanol as well as cyclohexaneethanol which belonging to saturated cyclic oxygenate have been investigated in a diesel engine.

DISSERTATIONS

1. Zhou, L. (30.09.2013). Emission reduction in compression-ignition engines by fuel tuning. Eindhoven: Eindhoven University of Technology ((Co-)promot.: prof.dr. L.P.H. de Goey, dr. N.J. Dam & dr.ir. M.D. Boot).

SCIENTIFIC PUBLICATIONS

1. Zhou, L., Dam, N.J., Boot, M.D. & Goey, L.P.H. de (2013). Measurements of sooting tendency in laminar diffusion flames of n-heptane at elevated pressure. *Combustion and Flame*, 160(11), 2507-2516.
2. Zhou, L., Boot, M.D. & Johansson, B.H. (2013). Comparison of emissions and performance between saturated cyclic oxygenates and aromatics in a heavy-duty diesel engine. *Fuel*, 113, 239-247.
3. Zhou, L., Boot, M.D. & Goey, L.P.H. de (2013). The effect of molecular structure on emissions and performance of a heavy-duty compression-ignition engine. *SAE International Journal of Engines*: 2013-01-2693.
4. Zhou, L., Boot, M.D. & Goey, L.P.H. de (2013). Gasoline – ignition improver – oxygenates blends as fuels for advanced compression ignition combustion. *SAE International Journal of Engines*: 2013-01- 0529.
5. Zhou L., Reijnders, J.J.E., Boot, M.D., Johansson, B.H. & Goey, L.P.H. de (2013). "Lignin-Derived Cyclic Oxygenates (CyclOx) as Alternative Fuel for Diesel Engines". 1st International Conference TMFB (Tailor-Made Fuels from Biomass), 18-20 June. 2013, Aachen, Germany.

DEVELOPING COMPREHENSIVE DIESEL COMBUSTION MODEL FOR HDDI TO PREDICT HEAT RELEASE RATE AND EMISSIONS (MAINLY SOOT)

PROJECT AIM

The main aim of the thesis work is to enhance FGM model capabilities to achieve a robust and complete model to predict diesel engine combustion processes, in a way to reduce the cost and time involved in numerical simulations. The current research work constituted of three focal areas aimed at

1. Improving the predictability of FGM for igniting diesel spray,
2. Accounting variations in pressure and (mainly) heat losses on the FGM chemistry in engine cycle simulations,
3. Including complex soot kinetics in FGM framework.

PROGRESS

1. ECN Spray Modeling: The in-cylinder combustion process in engines is greatly influenced by the igniting characteristics of a single diesel spray. The auto ignition phenomenon in a conditioned constant volume combustion chamber has been modeled using FGM approach. A wide set of experimental data from Engine Combustion Network (ECN) for Spray A is used for model validation. Refined FGM model showed decent match with the experimental observations. The causes for deviations observed at low temperature conditions are further investigated.

2. Engine Cycle Simulations: For engine simulations the FGM approach needs to incorporate the effect of changing pressure and the occurrence of heat-loss. The pressure dependent FGM model is further extended with enthalpy as additional dimension to account for the heat loss effect on chemistry evolution in CDC case. The pressure and enthalpy dependent FGM shows a minor improvement in the global characteristics like SOC and cylinder pressures, however the impact is significant on predictions of local temperature and species concentrations due to the cooling effect by walls. Consequently, the pressure and enthalpy dependent FGM showed a major influence on the NO_x predictions which are a strong function of local conditions.

3. Soot Modeling: A soot model incorporating detailed sub-process is included in FGM for the first time. The modeling of diesel soot formation and oxidation processes are complex and highly dependent on the accuracy of spray and gas phase chemistry predictions. The newly devised multi-step soot kinetics is first evaluated by generating and validating against published ϕ -T maps from literature, where the model showed a good agreement with key regions. Then, the 2-equation based soot model is coupled to the CFD simulation of Spray H case, whose reacting spray characteristics are in good agreement with experiments already. The fundamental phenomenology of soot formation and oxidation is well captured by the model. With the validation of the model results against the experimental data from ECN, it is concluded that the model based on 'well mixed approximation' predicts the transient nature of soot formation from diesel spray and captures the sensitivity of the change in ambient O₂ concentrations on soot formation qualitatively.

DISSERTATIONS

1. "Advances in the Application of Flamelet Generated Manifold for Diesel Engine Combustion Modeling", ISBN 978-90-386-3520-0.

SCIENTIFIC PUBLICATIONS

1. U. Egüz, S. Ayyapureddi, C. Bekdemir, L.M.T. Somers, L.P.H.de Goey, "Manifold resolution study of FGM method for an igniting diesel spray". FUEL (in press), DOI:10.1016/j.fuel.2013.05.090, 2013.

PROJECT LEADERS

LMT Somers, LPH de Goey

RESEARCH THEME

Complex dynamics of fluids

PARTICIPANTS

Sridhar Ayyapureddi

COOPERATIONS

DAF Trucks Eindhoven, TNO

FUNDED

SenterNovem

University -

FOM -

STW -

NWO Other 100 %

Industry -

TNO -

GTI -

EU -

Scholarships -

START OF THE PROJECT

2009

INFORMATION

Sridhar Ayyapureddi

040 247 35995

s.ayyapureddi@tue.nl

www.tue.nl/combustion

PROJECT LEADERS

LPH de Goey, LMT Somers

RESEARCH THEME

Mathematical and computational methods for fluid flow analysis

PARTICIPANTS

C Bekdemir, M Meijer

COOPERATIONS

University of California, San Diego
Institut Français du Pétrolé (IFPEN)

FUNDED

STW, DAF/PACCAR, Shell

| | |
|--------------|------|
| University | - |
| FOM | - |
| STW | 90 % |
| NWO Other | - |
| Industry | 10 % |
| TNO | - |
| GTI | - |
| EU | - |
| Scholarships | - |

START OF THE PROJECT

2008

INFORMATION

M Meijer
040 247 2877
m.meijer@tue.nl
www.tue.nl/combustion

Experimental surrogate fuel spray diagnostics: from left to right & top to bottom

- 1 Flamefront (spontaneous OH^{*}).
- 2 Inner and outer spray velocities (PIV).
- 3 Gas phase penetration (Schlieren).
- 4 Liquid penetration (Mie scattering)

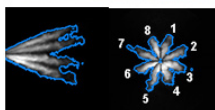
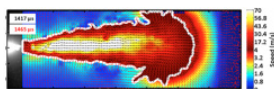
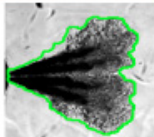
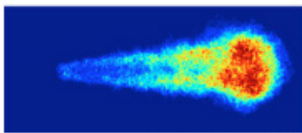

PROJECT AIM

Development, implementation and validation of a surrogate fuel concept for diesel engine combustion. The project combines both experimental and numerical work. The aim for the experimental part is to study surrogate fuels under engine relevant conditions in different fundamental set-ups with advanced optical diagnostics. The blend will be adapted such that both chemical and physical properties match the Diesel fuel as close as possible. The numerical work is performed by means of RaNS/LES and Flamelet Generated Manifold (FGM) based CFD in idealized and real engine conditions. Ultimately leading to a combined approach that can be applied to simulate fuel spray combustion and predict emission formation in engines, accurately and efficiently.

PROGRESS

Several ways to model fuel sprays (flow and turbulence) exist starting using RaNS and LES approaches. The latter can be much more detailed in the sense that they resolve large eddies and therefore inherently introduce stronger in-homogeneity like observed in practice. Concerning ignition and combustion a tabulated chemistry approach (FGM) is to be adopted. In order to apply these models successfully in the design of engines, appropriate and accurate diesel fuel characteristics have to be captured. Surrogate fuels are of interest to use in realistic injection and combustion simulations and experiments. Experiments in different constant volume combustion chambers are executed in order to study the behaviour of several primary surrogate-fuels. Experiments are executed within the Engine Combustion Network (<http://www.sandia.gov/ecn/>). New high speed optical measurement techniques suited for direct (CFD) modelling comparisons have been developed, implemented and results are published.

DISSERTATIONS

SCIENTIFIC PUBLICATIONS

1. Malbec, L.M., Egusquiza, J., Bruneaux, G. & Meijer, M. (2013). Characterization of a set of ECN Spray A injectors : nozzle to nozzle variations and effect on spray characteristics. *SAE International Journal of Engines*, 6(6), 1642-1660.
2. Meijer, M., Somers, L.M.T., Johnson, J., Naber, J., Lee, S.Y., Malbec, L.M., Bruneaux, G., Pickett, L.M., Bardi, M., Payri, R. & Bazyn, T. (2013). Engine combustion network (Ecn) : characterization and comparison of boundary conditions for different combustion vessels. *Atomization and Sprays*, 22(9), 777-806.
3. Meijer, M., Galle, J., Somers, L.M.T., Griensven, J.G.H. van & Verhelst, S. (2013). High-speed characterization of ECN spray A, using various diagnostic techniques. *SAE International Journal of Engines*, 6(2), 1238-1248.
4. Blessinger, M., Meijer, M., Pickett, L.M., Manin, J. & Skeen, S. (2013). Liquid/Vapor penetration and plume-plume interaction of vaporizing iso-octane and ethanol SIDI sprays. Oral : Proceedings of the 25th Annual Conference on Liquid Atomization and Spray Systems, 21-23 May 2013, Pittsburgh, (25, pp. 79-2013-1/12). Pittsburgh: ilass.org.
5. Blessinger, M., Meijer, M., Pickett, L.M., Skeen, S. & Manin, J. (2013). Quantitative Mixing Measurements and Stochastic Variability of a Vaporizing Gasoline Direct-Injection Spray. Oral : Proceedings of the 8th U.S. National Combustion Meeting, Western States Section of the Combustion Institute, 19-22 June 2013, Park City, Utah, Park City, UT, USA: Combustion Institute.

BIOMASS TO BIOFUELS

PROJECT AIM

Conversely, in this PhD project we reverse engineer, from the engine's perspective, which compounds should ideally be added to conventional fossil fuels to arrive at a more favorable overall engine performance (i.e. in terms of fuel economy and emissions). Second, a production route from biomass should be developed to produce these desired compounds from biomass. This project builds further on existing knowledge that so-called cyclic oxygenates should be targeted, specifically from lignin, a renewable waste-stream available in large volumes in the paper industry.

PROGRESS

To find out what kind of chemical structure is suitable to be an effective additive for decreasing the knock probability in modern SI engine, the impact of the chemical structure on combustion behavior on the gasoline engine condition is reviewed, And it is shown that the mono-aromatics have a longer ignition delay time in relatively low temperature, so a higher Research Octane Number (RON), higher Sensitivity and low Motor Octane Number (MON). So it is believed that the aromatics derived from lignin may have a good performance on knock resistance in SI engine, and this is what we will testify in the next step.

DISSERTATIONS

-

SCIENTIFIC PUBLICATIONS

-

PROJECT LEADERS

LPH de Goeij, MD Boot

RESEARCH THEME

Complex dynamics of fluids

PARTICIPANTS

M Tian

COOPERATIONS

-

FUNDED

Scholarship from China

University -

FOM -

STW -

NWO Other -

Industry -

TNO -

GTI -

EU -

Scholarships 100 %

START OF THE PROJECT

2012

INFORMATION

M Tian

m.tian@tue.nl

www.tue.nl/combustion

ADVANCED LOW NO_x FLEXIBLE FUEL GAS TURBINE COMBUSTION, AERO AND STATIONARY

PROJECT LEADERS

RJM Bastiaans, LPH de Goey,
JA van Oijen

RESEARCH THEME

Mathematical and computational
methods for fluid flow analysis

PARTICIPANTS

A Donini, S Mukhopadhyay

COOPERATIONS

Siemens Power Generation (SPG)
Rolls Royce Deutschland (RRD)

FUNDED

University, STW, SPG, RRD
University -
FOM -
STW 75 %
NWO Other -
Industry 25 %
TNO -
GTI -
EU -
Scholarships -

START OF THE PROJECT

2010

INFORMATION

RJM Bastiaans
040 247 4836
r.j.m.bastiaans@tue.nl
www.tue.nl/combustion

PROJECT AIM

In the current project detailed knowledge for modeling of combustion with alternative fuels will be developed. This is done by means of detailed descriptions in the framework of Computational Fluid Dynamics (CFD). The ultimate goal is to predict the combustion process of gas turbines, including complex physical real fuel phenomena (NO_x, preferential diffusion, thermo diffusive effects, etc.). To that end the promising flamelet generated manifolds (FGM) technique will be extended in this project. The technique is developed in its basic form at TU/e and has been continuously tested and extended to more general situations over the last years.

PROGRESS

Andrea:

Implementation of mixture fraction inclusion in the tool FGM construction. Ansys-CFX implementation of this technique for the 3D manifold. Testing in a simple 2D geometry. Inclusion of turbulence effects in the 5D FGM construction tool. Testing and validation on swirled gas turbine model combustor. Writing thesis.

Sudipto:

Development of 2D Filtered FGM M-(FFGM) for premixed combustion, Modeling insights into Progress variable variance, Comparison with presumed PDF manifold, Simulation of slot burner with M-FFGM and presumed PDF, Thesis writing.

DISSERTATIONS

-

SCIENTIFIC PUBLICATIONS

1. Donini, A., Martin, S.M., Bastiaans, R.J.M., Oijen, J.A. van & Goey, L.P.H. de (2013). Numerical simulations of a premixed turbulent confined jet flame using the flamelet generated manifold approach with heat loss inclusion. Proceedings of the ASME Turbo Expo 2013, 3-7 June 2013, San Antonio, Texas, (pp. GT2013-94363-1/10). ASME.
2. Donini, A., Martin, S.M., Bastiaans, R.J.M., Oijen, J.A. van & Goey, L.P.H. de (2013). High pressure jet flame numerical analysis of CO emissions by means of the flamelet generated manifolds technique. ICNAAM-2013, 21-27 September 2013, Rhodes, (AIP Conference Proceedings, 1558, pp. 136-139). Rhodes: AIP Publishing.
3. Donini, A., Bastiaans, R.J.M., Oijen, J.A. van & Goey, L.P.H. de (2013). The application of flamelet generated manifolds in the modeling of partially premixed cooled flames. Combustion Research and Application (COMBURA 2013), 9-10 October 2013, Maastricht, The Netherlands.
4. Mukhopadhyay S., Bastiaans, R.J.M., Oijen, J.A. van & Goey, L.P.H. de (2013). Application of explicit convolution to numerical modeling of turbulent combustion. ICNAAM-2013, 21-27 September 2013, Rhodes, (AIP Conference Proceedings, 1558, pp. 136-139). Rhodes: AIP Publishing.

EFFECTS OF PRESSURE AND TEMPERATURE ON COMBUSTION CHARACTERISTICS OF CELLULAR HYDROGEN FLAMES

PROJECT AIM

Hydrogen is expected to play an important role in future energy production, especially for the fuel of gas turbine engines. However, there are gaps in the fundamental understanding of hydrogen combustion characteristics at normal and elevated pressures and temperatures due to the high diffusivity, high reactivity of hydrogen. The aim of the project is to investigate the combustion characteristics of cellular hydrogen flames at elevated pressures and temperatures.

PROGRESS

Effects of Soret diffusion on lean hydrogen flames is on going.

DISSERTATIONS

-

SCIENTIFIC PUBLICATIONS

-

PROJECT LEADERS

RJM Bastiaans

RESEARCH THEME

Complex dynamics of fluids

PARTICIPANTS

Z Zhou

COOPERATIONS

-

FUNDED

Chinese Scholarship Council

University -

FOM -

STW -

NWO Other -

Industry -

TNO -

GTI -

EU -

Scholarships 100 %

START OF THE PROJECT

2013

INFORMATION

Z Zhou

Z.Zhou1@tue.nl

www.tue.nl/combustion

ULTRA EFFICIENT CLEAN COMBUSTION CONCEPTS AND THEIR FUEL APPETITE

PROJECT LEADERS

LPH de Goey, LMT Somers

RESEARCH THEME

Complex dynamics of fluids

PARTICIPANTS

S Wang

COOPERATIONS

-

FUNDED

Chinese Scholarship Council

University -

FOM -

STW -

NWO Other -

Industry -

TNO -

GTI -

EU -

Scholarships 100 %

START OF THE PROJECT

2013

INFORMATION

S Wang

040 247 5995

S.Wang@tue.nl

www.tue.nl/combustion

PROJECT AIM

Our goal is to conduct an intensive study on PPC, as well as RCCI.

An experimental comparison on a new-to-build single cylinder full-metal engine platform (based on a contemporary EURO VI HD engine) will deal with reaching the ultra high efficiency, ultra low emissions (EURO VI without catalysis and DPF) with a wide load range capability. At the same time, we will pay much attention on the composition and proportion of the fuel used in both concepts. The results will show both the achievable limits, as well as best points achievable with currently available fuels and engine hardware, using either of the combustion concepts.

PROGRESS

Partially premixed combustion, this concept is a hybrid between HCCI and conventional diesel combustion. Two promising PPC strategies under investigation today are gasoline PPC and dual-fuel RCCI. To get started, study on the ignition, combustion and emissions of HCCI combustion on the Cyclops fueled with BRF70 (n-butanol blends with iso-octane and n-heptane) and PRF70 have been done.

DISSERTATIONS

-

SCIENTIFIC PUBLICATIONS

-

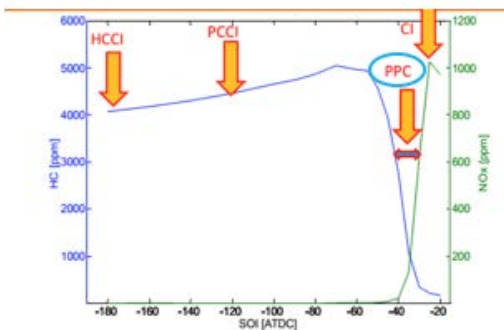

Def: region between truly homogeneous combustion, HCCI, and diffusion controlled combustion, diesel

Operational window for PPC [1-2]

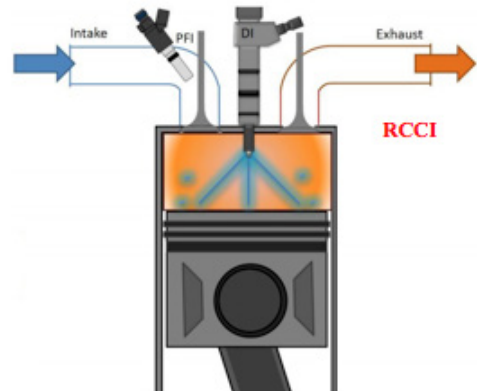

RCCI combustion using port-fuel-injection of a low reactivity fuel and direct-injection of a high reactivity fuel

DEVELOPMENT OF RELIABLE EMISSION AND ATOMIZATION MODELS FOR COMBUSTOR DESIGN

PROJECT AIM

Aim of this project is to develop an accurate and reliable computational tool for prediction of emissions in lean burn combustion systems for civil aerospace applications. Within this project, the research carried out by TU/e will concentrate on the chemistry reduction method Flamelet-Generated Manifold (FGM), which is intended to reduce the computational cost of the complex chemistry models for application in CFD codes. Improved flamelet tabulation techniques are to be developed focusing on accurate prediction of CO, UHC, NOx and soot emissions from gas turbine combustors.

PROGRESS

Detailed chemistry 1D flame calculations including mimicked isentropic expansion in the post flame zone (process encountered in gas turbine stator) have been performed. Preliminary validation of FGM tabulated chemistry has been performed, utilizing enthalpy and pressure as additional controlling variables (to account for stator conditions), against aforementioned 1D detailed chemistry cases.

DISSERTATIONS

-

SCIENTIFIC PUBLICATIONS

-

PROJECT LEADERS

JA van Oijen

RESEARCH THEME

Mathematical and computational methods for fluid flow analysis

PARTICIPANTS

D Efimov

COOPERATIONS

Rheinisch-Westfälische Technische Hochschule Aachen. Karlsruher Institut für Technologie. Imperial College of Science, Technology and Medicine, London.

FUNDED

| | |
|--------------|-------|
| EU | |
| University | - |
| FOM | - |
| STW | - |
| NWO Other | - |
| Industry | - |
| TNO | - |
| GTI | - |
| EU | 100 % |
| Scholarships | - |

START OF THE PROJECT

2013

INFORMATION

JA.van Oijen

040 247 3133

j.a.v.oijen@tue.nl

www.tue.nl/combustion

FLAMEBALLS, CELLS AND CUSPS IN ULTRA-LEAN HYTHANE-AIR MIXTURES

PROJECT LEADERS

RJM Bastiaans

RESEARCH THEME

Complex dynamics of fluids

PARTICIPANTS

RJM Bastiaans, LPH de Goey,
Y Shoshin, F Hernandez Perez,
J van Oijen, B Oostenrijk,
A Manteghi, N Dam, A Sepman

COOPERATIONS

STW, Shell, Vattenfall-Nuon,
University of Groningen

FUNDED

| | |
|--------------|-------|
| STW | |
| University | - |
| FOM | - |
| STW | 100 % |
| NWO Other | - |
| Industry | - |
| TNO | - |
| GTI | - |
| EU | - |
| Scholarships | - |

START OF THE PROJECT

2011

INFORMATION

Y Shoshin
040 247 5689
Y.S.Shoshin@tue.nl
www.tue.nl/combustion

PROJECT AIM

Hydrogen-containing blends exhibit a very specific combustion behavior. Due to the high diffusivity of hydrogen, flames are strongly affected by so-called preferential diffusion effects. The project is aimed on acquiring deep knowledge on the mentioned effects. To meet this goal a detailed experimental study using (ultra) lean two-dimensional laminar stationary flames of hydrogen-methane air mixtures is being carried out. The experiments are setup to model all key structural elements of cellular flames: 1. Flame cells; 2. Flame balls (in ultra-lean mixtures); 3. Flame cusps separating the cells. In addition, hydrogen-methane-air flames stabilization mechanisms are being studied. To this end, novel Flameball burner and multi-slot cooled 2-D Bunsen burner are designed and built. Extensive quantitative spatially resolved laser diagnostics for measuring concentrations of reacting species will be employed.

PROGRESS

Raman scattering measurements for main species and temperature detailed distributions for normal gravity flame balls and for ultra-lean 2D flames of hydrogen-methane-air mixtures. 2. Numerical simulations of normal gravity flameballs have been performed and selected chemical/transport models tested by comparison with the experimental results. 3. The TLAF optical setup has been modified to perform measurement in the signal saturation regime, increasing thereby the method sensitivity and reducing the error. 4. Influence of preferential diffusion effects on behavior of lean inverted flames studied experimentally and by numerical simulations. Mechanism of the influence of mixture Lewis number of the flame stabilization/blow-off parameters suggested.

DISSERTATIONS

1. Hernandez Perez, F.E., Groth, C.P.T. & Gulder, O.L. (2013). LES of a hydrogen-enriched lean turbulent premixed flame. Proceedings of the 51st aerospace science meeting, Texas: AIAA 2013-1139.

SCIENTIFIC PUBLICATIONS

1. Hernandez Perez, F.E., Oijen, J.A. van & Goey, L.P.H. de (2013). Computational study on the stability of lean CH₄-air and H₂-CH₄-air laminar premixed flames. Oral : Proceedings of the European Combustion Meeting 2013 (ECM), 25-28 June 2013, Lund, Sweden, (pp. 1-5).
2. Hernandez Perez, F.E., Oijen, J.A. van & Goey, L.P.H. de (2013). LES of MILD combustion : Delft jet-in-hot-coflow flame. Oral : Proceedings of the 14th International Conference on Numerical Combustion, 8-10 April 2013, San Antonio, Texas, USA, SIAM.



Prof.dr.ir. JJH Brouwers



Prof.dr. M Golombok

The programme of the group covers theoretical, numerical and experimental research on selected subjects in process technology. The subjects range from fundamentals to applications. The aims are to contribute to scientific issues relevant to the field, to develop tools for applying scientific results on practical cases and to design machinery and apparatus using these results.

Many research activities are carried out in co-operation with and with support from industry.

The subjects of research are:

1. Stochastic processes and turbulence

The stochastic process of turbulence is a key issue in process technology, since fluid flow in process apparatus is generally turbulent and predicting flow quantities is a central issue in their design. A theory has been developed for stochastic turbulence, which involves asymptotically exact solution methods and reveals the truncation errors. The theory has been validated by means of direct numerical simulation. Concerning numerical research, faster and more efficient numerical methods for DNS and LES models for particle-laden turbulent flow are being developed. Experimental research into inhomogeneous turbulence at intermediate and high Reynolds number is carried out by means of 3D-PTV in turbulent pipe flow.

2. Phase-transitional flow

Fluid flow in which a phase change occurs is of considerable importance in process technology. The research is focused on boiling, (dropwise) condensation and sublimation. The research is generic, aiming at results that are applicable in numerical methods and for the design of unit operations. As examples, the dependencies of drag and lift force coefficients on acceleration of bubbles and particles have been studied and the effect of the velocity field caused by condensation directly downstream of the inlet of a confined steam jet on self-similarity has been investigated. Current research focuses on inertia-dominated interaction of flow and bubbles or particles and on basic mechanisms of condensation and sublimation. The approach followed is analytical, experimental and numerical.

3. Development of new process technology

The insights gained in the first two topics are applied to new concepts of process technology, mainly in the area of rotational equipment, separation apparatus and heat and mass exchangers. These projects are carried out in close cooperation with industry and comprise the design, manufacturing and testing of new equipment. Centrifugal phase separation offers excellent opportunities for innovation. The group has a strong position in this field by the patented concept of rotational particle separation. A new development is the design where rotation is generated by swirl of the flow itself, which is particularly suited at high fluid pressures and receives much interest from the oil industry. A new in-house born idea is the wall-de-sublimator, which avoids the formation of aerosols by de-sublimating vapors on cooled surfaces of narrow-channeled heat exchangers. A relatively new means of ship propulsion is based on waterjets driven by pumps. The group studies the effects of non-uniform intake flow on performance and forces of the pump. A project on the development of a numerical method for unsteady flow in rotating machinery just started.

PARTICLE-PARTICLE INTERACTION IN BIOMASS CO-FIRING POWER PLANTS

PROJECT AIM

In this project interaction between different kinds of particles and between particles and flow will be studied in which the properties of the particles, such as size, temperature and chemical composition change in time because of combustion and flow of the surrounding gas. Particles will be treated as point particles, but detailed numerical simulations will be carried out to obtain correlations for the processes that take place in a particle. Interaction between particles by radiation will be included.

PROGRESS

A start has been made by treating the combustion processes that take place after pyrolysis of biomass particles. This has first been tested in a stand-alone code for a single particle and is now being implemented in a DNS code with many particles.

DISSERTATIONS

-

SCIENTIFIC PUBLICATIONS

-

PROJECTLEADERS

JGM Kuerten

RESEARCHTHEME

Complex dynamics of fluids

PARTICIPANTS

A Awasthi, JGM Kuerten

COOPERATIONS

B.J. Geurts (UT)

FUNDED

FOM/Shell

University -

FOM 100 %

STW -

NWO Other -

Industry -

TNO -

GTI -

EU -

Scholarships -

START OF THE PROJECT

2013

INFORMATION

JGM Kuerten

040 247 2362

.g.m.kuerten@tue.nl

www.wtb.tue.nl/woc/ptc

PROJECT LEADERS

JGM Kuerten

RESEARCH THEME

Complex dynamics of fluids

PARTICIPANTS

W Michalek, JGM Kuerten

COOPERATIONSProf. dr. A. Soldati, Dr. C. Marchioli,
University of Udine, Italy, Prof. dr.B.J. Geurts, UT, Dr. J. Pozorski,
Polish Academy of Sciences,
Gdansk.**FUNDED**

STW, TU/e, DEISA

University 15 %

FOM -

STW 85 %

NWO Other -

Industry -

TNO -

GTI -

EU -

Scholarships -

START OF THE PROJECT

2003

INFORMATION

JGM Kuerten

040 247 2362

j.g.m.kuerten@tue.nl

www.wtb.tue.nl/woc/ptc

PROJECT AIM

The aim of this project is the study of dispersion of non-passive particles in turbulent non-isothermal channel flow by means of DNS and LES. Especially models for subgrid contributions in case LES is used for the fluid flow are developed and tested, both for particle velocity and particle temperature.

PROGRESS

Dispersion of non-passive particles in turbulent non-isothermal channel flow is studied by means of DNS and LES. A model for the subgrid contribution in the particle equation of motion has been developed and shows a substantial improvement in the statistical results of LES. For larger Reynolds numbers a combination of a stochastic model and the deterministic model based on approximate deconvolution mentioned above has been proposed and tested. The stochastic model is based on a priori results from DNS.

DISSERTATIONS

-

SCIENTIFIC PUBLICATIONS

1. W.R. Michalek, J.G.M. Kuerten, J.C.H. Zeegers, R. Liew, J. Pozorski, B.J. Geurts, A hybrid stochastic-deconvolution model for LES of particle-laden flow, *Phys. Fluids*, 25, 123302 (2013).
2. W. Michalek, J.G.M. Kuerten, R. Liew, J.C.H. Zeegers, B.J. Geurts, A hybrid stochastic-deconvolution model for particle-laden LES, , *Proceedings of the 11th International Conference on Numerical Analysis and Applied Mathematics 2013*, Ed. T. Simos, AIP Conference Proceedings 1558.

BiOxyFuel: TORREFIED BIOMASS COMBUSTION UNDER OXY-FUEL CONDITIONS IN COAL-FIRED POWER PLANTS

PROJECT AIM

In this project interaction between different kinds of particles and between particles and flow will be studied in which the properties of the particles, such as size, shape, temperature and chemical composition change in time because of combustion and flow of the surrounding gas. Particles will be treated as point particles, but detailed numerical simulations will be carried out to obtain correlations for the forces on a particle.

PROGRESS

An existing DNS code for Lagrangian simulations of point particles has been extended with equations for temperature and species concentration. Two-way coupling between gas and particle temperature has been incorporated. A compressible DNS code has been developed with particles and two-way coupling in which the particles represent biomass particles and undergo pyrolysis. A combination of biomass and coal particles has been implemented and the effect of the presence of biomass particles on the pyrolysis of coal has been investigated.

DISSERTATIONS

-

SCIENTIFIC PUBLICATIONS

1. E. Russo, J.G.N. Kuerten, C.W.M. van der Geld, B.J. Geurts, Water circulation in non-isothermal droplet-laden turbulent channel flow, Proceedings of the 11th International Conference on Numerical Analysis and Applied Mathematics 2013, Ed. T. Simos, AIP Conference Proceedings 1558.

PROJECT LEADERS

JGM Kuerten

RESEARCH THEME

Complex dynamics of fluids

PARTICIPANTS

E Russo, JGM Kuerten, CWM van der Geld

COOPERATIONS

JA van Oijen, Y Haseli (TU/e)

EM Gucho, G Brem, BJ Geurts (UT)

FUNDED

| | |
|--------------|-------|
| STW | |
| University | - |
| FOM | - |
| STW | 100 % |
| NWO Other | - |
| Industry | - |
| TNO | - |
| GTI | - |
| EU | - |
| Scholarships | - |

START OF THE PROJECT

2010

INFORMATION

JGM Kuerten

040 247 2362

j.g.m.kuerten@tue.nl

www.wtb.tue.nl/woc/ptc

EFFECTS OF CROSS-SECTION VARIATION AND BUBBLE-BUBBLE INTERACTION ON BUBBLE DETACHMENT IN CONVECTIVE FLOW

PROJECT LEADERS

CWM van der Geld, JGM Kuerten

RESEARCH THEME

Complex dynamics of fluids

PARTICIPANTS

C Baltis, J Desmarais, CWM van der Geld, JGM Kuerten

COOPERATIONS

DAF, Spirotech B.V.

FUNDED

STW

University -

FOM -

STW 100 %

NWO Other -

Industry -

TNO -

GTI -

EU -

Scholarships -

START OF THE PROJECT

2010

INFORMATION

CWM van der Geld

040 247 2923

c.w.m.v.d.geld@tue.nl

www.wtb.tue.nl/woc/ptc

PROJECT AIM

The effect of flow on boiling bubble detachment from a heated plane wall is investigated for the effects mentioned in the title. Experiments serve to validate a model based on the diffuse interface method that will be further developed.

PROGRESS

In 2013 the boundary conditions for the diffuse interface model have been further developed based on extensions of the characteristic method and the method of perfectly matched layers. Also solid-wall boundary conditions have been studied and implemented. In 2013 a new measuring technique of instantaneous temperature fields in liquid, based on the use of phosphoric tracers, has been further developed and a paper has been submitted about it. Measurements have been performed with the new test section with multiple bubble generators at artificial sites. The electric conditioning has been detailedly analyzed.

DISSERTATIONS

-

SCIENTIFIC PUBLICATIONS

1. J.L. Desmarais, J.G.M. Kuerten, Extension of the 1-D characteristic open boundary conditions to the diffuse interface model, in: Computational Methods in Multiphase Flow VII, Eds. C. A. Brebbia, P. Vorobieff, p. 115-125, 2013.

BIO-STIPS

PROJECT AIM

The aim of this research is to develop a model for the calculation of the thickness of deposition that results after evaporation of a solvent from a droplet and of the distribution of (bio)molecules on/in the substrate.

PROGRESS

This project has been finished in 2012.

DISSERTATIONS

-

SCIENTIFIC PUBLICATIONS

1. D.P. Siregar, J.G.M. Kuerten, C.W.M. van der Geld, Numerical simulation of the drying of inkjet-printed droplets, *J. Colloid and Interface Science*, 392, 388-395, (2013).

PROJECTLEADERS

JGM Kuerten

RESEARCHTHEME

Complex dynamics of fluids

PARTICIPANTS

DP Siregar, CWM van der Geld,

JGM Kuerten

COOPERATIONS

WUR, Philips Research. Océ

FUNDED

STW

University -

FOM -

STW 100 %

NWO Other -

Industry -

TNO -

GTI -

EU -

Scholarships -

START OF THE PROJECT

2008

INFORMATION

JGM Kuerten

040 247 2362

j.g.m.kuerten@tue.nl

www.wtb.tue.nl/woc/ptc

STATISTICAL ANALYSIS OF TURBULENT TWO-PHASE PIPE FLOW BY MEANS OF EXPERIMENTS

PROJECT LEADERS

CWM van der Geld, JGM Kuerten

RESEARCH THEME

Complex dynamics of fluids

PARTICIPANTS

JL Goes Oliveira, CWM van der
Geld, JGM Kuerten.

COOPERATIONS

-

FUNDED

TU/e

University 100 %

FOM -

STW -

NWO Other -

Industry -

TNO -

GTI -

EU -

Scholarships -

START OF THE PROJECT

2003

INFORMATION

CWM van der Geld

040 247 2923

c.w.m.v.d.geld@tue.nl

www.tue.nl

PROJECT AIM

The aim of this research is to determine the statistical properties of inhomogeneous turbulence at intermediate and high Reynolds numbers, the effect of particles with inertia on these properties and the effects of flow orientation with respect to gravity and state of development of the flow.

PROGRESS

In 2013, a paper and the thesis of Jorge Goes have been written. The analysis of particle laden flow is focused on the effect of turbulence on drag and lift in two regions of pipe flow. Different particle concentrations were measured in upflow and downflow of nearly neutrally buoyant solid particles.

DISSERTATIONS

-

SCIENTIFIC PUBLICATIONS

1. J.L.G. Oliveira, C.W.M. van der Geld, J.G.M. Kuerten, Lagrangian and Eulerian statistics of pipe flows measured with 3D-PTV at moderate and high Reynolds numbers, *Flow, Turbulence and Combustion*, 91(1), 105-137 (2013).



Prof.dr.ir. D Smeulders



Prof.dr.ir. AA van Steenhoven



Prof.dr. A Dietzel

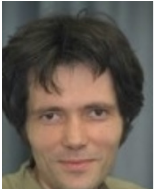

Prof.dr. H Zondag

Research in the field of Energy Technology at a Mechanical Engineering Department requires the combination of fundamental research and the study of engineering systems and devices. The fundamental research is in the field of Heat Transfer, and the engineering system focuses on small-scale Energy Systems with a strong emphasis on sustainability.

The approach is to combine advanced experimental, analytical and numerical techniques to investigate fundamental topics in heat transfer, and to design, construct and test real energy conversion systems. In this way, the research also contributes to the engineering and research training of the mechanical engineering students. The research is concentrated on three topics:

A. HEAT TRANSFER AND TRANSITIONAL FLOWS.

The research in this area is aimed at a better understanding of the fundamental characteristics of transitional flows in general. Flow cases that are studied are bypass transition along a flat plate (related to turbine blade cooling), laminar thermal transport in compact systems and boiling process control (for heat removal and thermal homogenisation in, for example, lithographic systems). Another research line concentrates on non-equilibrium phase transitions in gas-vapor mixtures.

B. MICRO-SCALE HEAT TRANSFER AND FLOW PHENOMENA

The aim of this research line is to achieve a better understanding of the heat and mass transfer processes at the small scales. The focus is on evaporative cooling of electronic components, on multi-scale analysis for compact heat storage materials and permeable geothermal reservoirs, and the dynamics of integrated fluid drivers in micro systems. On the smallest scales the physical processes are studied by coupling Molecular Dynamics analysis with a Direct Simulation Monte Carlo model.

C. HEAT TRANSFER ENGINEERING

The research activities in this area focus more on the system level rather than on the phenomenological level. Main research projects are fouling of heat exchangers used in waste- incinerators and biomass gasifiers, the design of a humidity harvesting device, and heat transfer models in the built environment. Another research line concentrates on biomass reactors for thermo-chemical applications.

More information about the research activities in these areas can be found on our website: www.energy.tue.nl

NUMERICAL MODELING OF HYDRAULIC FRACTURING

PROJECT AIM

The aim of this project is to develop a numerical model to predict the propagating fracture patterns that grow during hydraulic fracturing processes. Such a numerical model may be useful to identify key parameters in the hydraulic fracturing process and may be helpful to optimize the fracture process.

PROGRESS

We developed a 2D numerical fracture model. This model includes poroelastic effects in the rock formation, the tangential flow in the fracture, the exchange of fluid between the fracture and the formation, and fracture propagation in arbitrary directions. The pressure in the fracture is included as a separate degree of freedom. The numerical model is validated with an analytical KGD fracture model. Hydraulic fracture propagation growing from a 2D circular borehole is considered. In this example we show that the preferred propagation direction of a hydraulic fracture is perpendicular to the minimum confining stress.

DISSERTATIONS

-

SCIENTIFIC PUBLICATIONS

1. Fifth Biot Conference on Poromechanics, July 10-12 Vienna.
E.W.Remij, F.Pizzocolo, J.J.C. Remmers, D.M.J. Smeulders, and J.M.Huyghe, (2013), ' Nucleation and mixed mode crack propagation in a porous material', Poromechanics V, 2260-2269.

PROJECT LEADERS

DMJ Smeulders, JM Huyghe

RESEARCH THEME

Mathematical and computational methods for fluid flow analysis

PARTICIPANTS

JM Huyghe, JJC Remmers, EW Remij

COOPERATIONS

-

FUNDED

TKI Upstream Gas
University -
FOM -
STW -
NWO Other -
Industry 100 %
TNO -
GTI -
EU -
Scholarships -

START OF THE PROJECT

2013

INFORMATION

DMJ Smeulders
d.m.j.smeulders@tue.nl

LAGRANGIAN “MIXING ANALYSIS” OF HEAT TRANSFER: A NEW WAY FOR THERMAL OPTIMISATION

PROJECT LEADERS

MFM Speetjens, HJH Clercx
(AP-TU/e), AA van Steenhoven

RESEARCH THEME

Mathematical and computational
methods for fluid flow analysis

PARTICIPANTS

EA Demissie

COOPERATIONS

O Baskan (PhD candidate of
companion project at Dept. Applied
Phys., TU/e), G. Metcalfe, CSIRO-
MMT, Melbourne, Australia, F.
Posthuma-Scholtes, Primix BV,
Mijdrecht, B. Ohlmeier, DSM
Research, Geleen

FUNDED

STW-11054 (two companion PhD-
Projects at TU/e; one at Dept. Mech.
Eng., one at Dept. Applied. Phys.)

| | |
|--------------|-------|
| University | - |
| FOM | - |
| STW | - |
| NWO Other | 100 % |
| Industry | - |
| TNO | - |
| GTI | - |
| EU | - |
| Scholarships | - |

START OF THE PROJECT

2011

INFORMATION

MFM Speetjens
040 247 5428
m.f.m.speetjens@tue.nl
www.energy.tue.nl

PROJECT AIM

Heat transfer admits representation in terms of the “motion of a “fluid.” This fundamental change in thermal modelling enables thermal analysis in terms of the thermal trajectories (thermal counterpart to fluid trajectories) by well-established – and very successful – methods from mixing studies. This Lagrangian mixing analysis of heat transfer offers promising new thermofluid-engineering capabilities beyond those of conventional Eulerian approaches based on e.g. temperature fields. Aim of the study is further development of this concept for practical utilisation by way of representative industrial heat exchangers based on the static-mixing principle.

PROGRESS

The computational toolbox for simulation of 3D Lagrangian coherent structures (LCSs) in flow fields has been extended by a volume-preserving integration algorithm. This proved essential to reliably determine LCSs. This extended toolbox has been tested on a number of analytical case studies and is currently being employed for simulation and analysis of 3D LCSs and their role in the transport properties of the Rotated Arc Mixer (RAM), a representative industrial heat-exchanger/mixer. Subjects of investigation are the role of the flow transition between consecutive mixer segments and fluid inertia on these LCSs.

DISSERTATIONS

-

SCIENTIFIC PUBLICATIONS

1. B.A. Mosovsky, M.F.M. Speetjens, J.D. Meiss, J.D., Finite-time transport in volume-preserving flows. *Phys. Rev.Lett.* 110, 214101 (2013).

Bifurcation in 3D Lagrangian flow structure induced by fluid inertia (Re): (a) one family of concentric streamtubes for Re=10; (b) multiple families of streamtubes for Re=100. Shown are 3D streamlines (left) and the corresponding cross-sections with the inlet (right). Colours indicate individual streamlines.

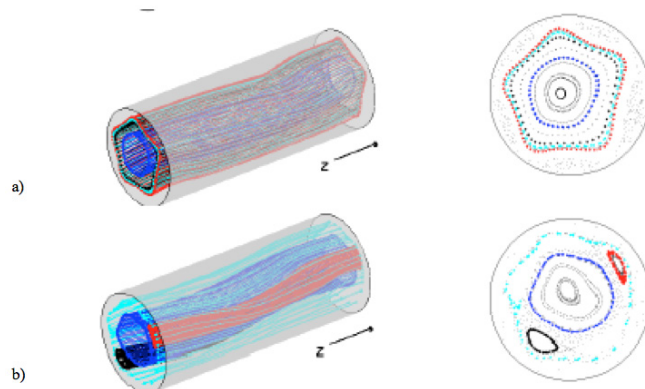

HOMOGENEOUS WATER NUCLEATION: PULSE-EXPANSION WAVE TUBE EXPERIMENTS

PROJECT AIM

The aim of the project is to investigate homogeneous nucleation of water/CO₂ droplets in carrier gases under non-equilibrium conditions (wave expansion experiments). This is of interest because of CCUS in the Netherlands (Carbon Capture Utilisation and Storage). Moreover, also for the production of LNG (liquefied Natural Gas), these condensation phenomena of paramount importance.

PROGRESS

First, the last series of water condensation experiments with the mixture H₂O-N₂ has been performed; conditions of nucleation were restricted to 10 bar a and 240 K. This data set - together with the existing data sets (2012) - was re-analyzed and, subsequently, used to prepare a manuscript, which is currently under review. Subsequently, an exchange project (March-June 2013) with the Academy of Sciences of the Czech Republic was arranged. Experiments were conducted to study the surface tension, which is an important parameter in modeling nucleation, of pure water in the temperature regime below 0°C. After that, dissemination of experimental results by means of oral presentations took place at three relevant international conferences. Last of all, the experimental setup was tested and updated. Preparations for experiments at both low (1 bar a) and elevated (25 bar a) were performed. These new experiments are scheduled for 2014.

DISSERTATIONS

-

SCIENTIFIC PUBLICATIONS

1. Fransen, M.A.L.J., Sachtelben, E., Hruby, J. & Smeulders, D.M.J. (2013). Homogeneous nucleation of water in synthetic air. In P.J. DeMott & C.D. O'Dowd (Eds.), Oral : Proceedings of the 19th International Conference on Nucleation and Atmospheric Aerosols, 23-28 June 2013, Fort Collins, Colorado, (AIP Conference Proceedings, 1527, pp. 124-127). New York: AIP Publishing.

PROJECT LEADERS

DJM Smeulders

RESEARCH THEME

Complex dynamics of fluids

PARTICIPANTS

DMJ Smeulders, M Fransen

COOPERATIONS

Dr. Jan Hrubý, Academy of Sciences of the Czech Republic, Prague, Czech Republic

FUNDED

| | |
|--------------|-------|
| TU/e | |
| University | 100 % |
| FOM | - |
| STW | - |
| NWO Other | - |
| Industry | - |
| TNO | - |
| GTI | - |
| EU | - |
| Scholarships | - |

START OF THE PROJECT

2011

INFORMATION

M Fransen

040 247 2816

m.a.l.j.fransen@tue.nl

PROJECT LEADERS

AJH Frijns, AA van Steenhoven,
DMJ Smeulders

RESEARCH THEME

Mathematical and computational
methods for fluid flow analysis

PARTICIPANTS

SV Nedeia, JH Kim

COOPERATIONS

GASMEMS

FUNDED

| | |
|--------------|-------|
| FP7 | |
| University | - |
| FOM | - |
| STW | - |
| NWO Other | - |
| Industry | - |
| TNO | - |
| GTI | - |
| EU | 100 % |
| Scholarships | - |

START OF THE PROJECT

2013

INFORMATION

A Frijns
040 247 4825
a.j.h.frijns@tue.nl
www.energy.tue.nl

PROJECT AIM

The occurrence of acute and chronic cardiovascular complications in dialysis patients is high. Insufficient correction of uremic state by conventional dialysis plays an important underlying role. Conventional hemodialysis uses a 'one size fits all' approach with a fixed dialysate concentration of electrolytes. Individualization of dialysate prescription is hampered because no suitable on-line ion-selective electrolyte monitoring is available. This project aims to develop and compare novel optical sensor technologies for continuous ion-selective monitoring of electrolytes in dialysate.

PROGRESS

Optical sensors offer intrinsic electrical safety (no galvanic contact), good miniaturization perspective, improved biocompatibility (contactless sensing), less fouling and simultaneous measurement of multiple ions. We investigate two novel optical sensor technologies based on: Photo-induced electron transfer (PET) and laser induced breakdown spectroscopy (LIBS). We built first lab set-ups for testing both optical sensor techniques. Our results show that both optical sensor principles indeed work. Further research on optimization and miniaturization is ongoing.

DISSERTATIONS

-

SCIENTIFIC PUBLICATIONS

-

PROJECT AIM

The heat transfer in (laminar) micro-flows depends essentially on the topology of the Lagrangian fluid paths. Aim of the study is to investigate the fundamental connection between heat transfer and flow topology and to explore its potential with regard to control and optimisation of heat transfer in micro-flows.

PROGRESS

Experimental studies on the 3D flow structure of a micro-flow driven by way of AC electro-osmosis (ACEO) have been continued. Goal was further experimental characterization of the 3D velocity field and flow structure and its comparison with numerical simulations. To this end 3D flow measurements using 3D micro-Particle-Tracking Velocimetry (3D μ PTV) have been performed. This exposed electrode-wise symmetric pairs of 3D vortical structures and corresponding quasi-2D primary circulations that are in good qualitative agreement with numerical observations. More detailed (quantitative) investigations are in progress.

DISSERTATIONS

-

SCIENTIFIC PUBLICATIONS

-

Vortical structure of a 3D ACEO micro-flow measured by 3D μ PTV: 3D trajectories visualizing electrode-wise symmetric pairs of 3D vortices (black vs. blue; red indicates trajectories crossing the symmetry plane).

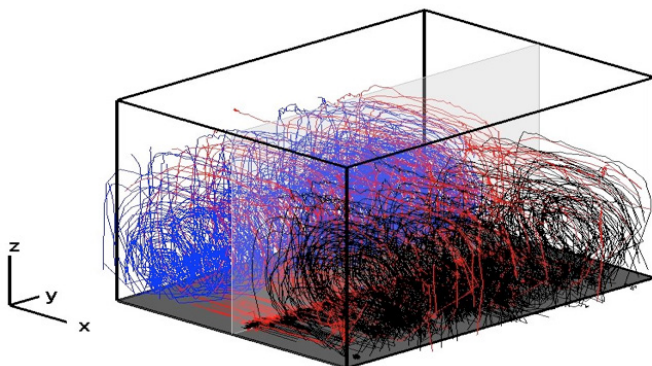

PROJECT LEADERS

MFM Speetjens, AJH Frijns,
AA van Steenhoven

RESEARCH THEME

Complex structures of fluids

PARTICIPANTS

Z Liu, PR Bloemen

COOPERATIONS

C Cierpka, Universität der
Bundeswehr, München, Germany

FUNDED

| | |
|--------------|-------|
| TU/e-W | |
| University | 100 % |
| FOM | - |
| STW | - |
| NWO Other | - |
| Industry | - |
| TNO | - |
| GTI | - |
| EU | - |
| Scholarships | - |

START OF THE PROJECT

2007

INFORMATION

M Speetjens
040 247 5428
m.f.m.speetjens@tue.nl
www.energy.tue.nl

Quasi-2D primary circulation measured by 3D μ PTV: (a) raw velocity data; (b) field interpolated on a regular grid including streamlines (colours indicate magnitude).

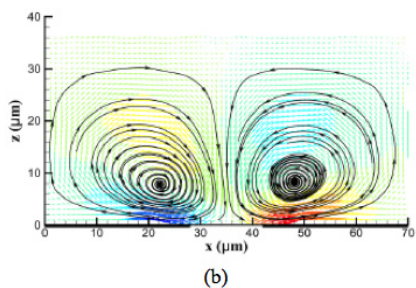
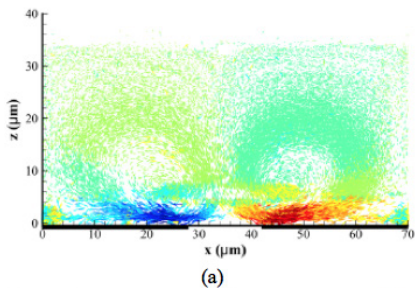

INTEGRATED MICRO-FLUIDIC COOLING IN LAMINATED FLEXIBLE MICRO-SYSTEMS

PROJECT LEADERS

AJH Frijns, AA van Steenhoven,
DMJ Smeulders

RESEARCH THEME

Complex dynamics of fluids

PARTICIPANTS

G Gürsel, D Florea, E Homburg

COOPERATIONS

Philips, Holst Centre

FUNDED

| | |
|--------------|-------|
| STW | |
| University | - |
| FOM | - |
| STW | 100 % |
| NWO Other | - |
| Industry | - |
| TNO | - |
| GTI | - |
| EU | - |
| Scholarships | - |

START OF THE PROJECT

2001

INFORMATION

A Frijns
040 247 4825
a.j.h.frijns@tue.nl
www.energy.tue.nl

PROJECT AIM

Electronic devices will in the future be made more and more also as flexible system-in-foil (SIF) which can contain ultra-thin (15 – 50 micron) flexible embedded silicon chips. A challenge is given by the low thermal conductivity of the very thin polymeric package aggravating the heat management problem. The aim of this project to develop an integrated micro-fluidic cooling system in a laminated flexible micro-system.

PROGRESS

A new modelling approach was followed: the system is modelled by a non-linear mass-spring-damper system and was implemented in SIMULINK. Main advantages of such approach that the results are easier to interpret than in a CFD model, since it can be related to the non-linear springs and dampers. Therefore, the effects of asymmetry in filling and in material properties and the stability issues can be better addressed. Evaporation and condensation are included in de model and a first analysis on the effects of asymmetry in the system is done.

DISSERTATIONS

-

SCIENTIFIC PUBLICATIONS

-

Pulsating heat pipe (left) and oscillatory motion of a plug (right).

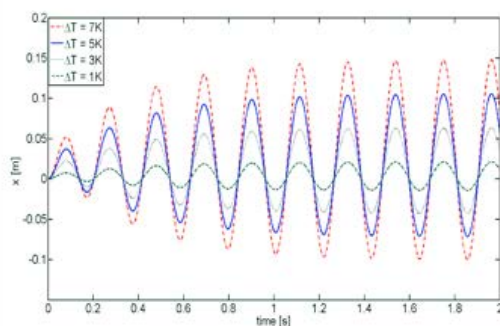
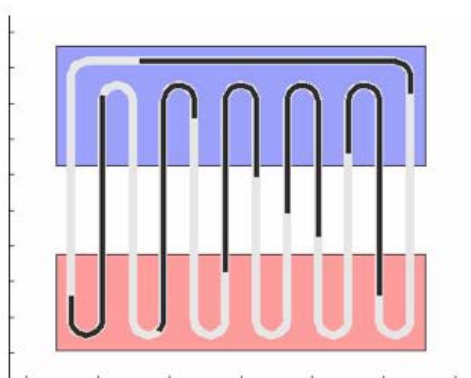

MOLECULAR SIMULATIONS TO STUDY THE COMPACT HEAT STORAGE MATERIALS

PROJECT AIM

This study focuses on the dynamics of hydration and dehydration reactions of salt hydrates ($MgSO_4 \cdot 7H_2O$, $MgCl_2 \cdot xH_2O$ etc) from a molecular point of view. The project aims to identify the molecular and structural parameters which limit the kinetics and usability of salt hydrates as thermochemical heat storage materials. This study will help to classify such materials based on their storage efficiency, usability, kinetics, reusability etc. This information can be used to identify the best suitable material for thermochemical heat storage.

PROGRESS

Molecular and crystalline structures of $MgSO_4$ hydrates have been refined using Quantum Chemical (DFT) methods. Presence of an extensive network of hydrogen bonds in the structures seem to be influencing the kinetics of hydration and dehydration reactions. Thus, the meta-stability of sulfate based hydrates can be attributed to these strong hydrogen bonds. A reactive molecular dynamics force-field is developed using a newly developed application of Metropolis Monte-Carlo algorithm with simulated annealing. DFT data such as optimized geometries, equations of states, binding energy etc were used for parameterizing the force-field. The force-field appeared to reproduce the characteristics of the complicated potential energy surface of magnesium sulfate-water system. Simulation results show evidences for the decomposition of water molecules during the dehydration process. The preference of hydrolysis over dehydration of $MgCl_2$ hydrates are studied using equilibrium principles. The study performed on the gas phase molecules shows that the hydrolysis is less favorable during dehydration unless at very high temperatures.

DISSERTATIONS

-

SCIENTIFIC PUBLICATIONS

1. Iype, E., Hutter, M., Jansen, A. P. J., Rindt, C. C. M., 2013. J. Comp. Chem. 34 (13), 1143-1154.
2. Smeets, B., Iype, E., Nedeá S. V., Zondag, H. A., Rindt, C. C. M., 2013. J. Chem. Phys. 139 (12). 124312.

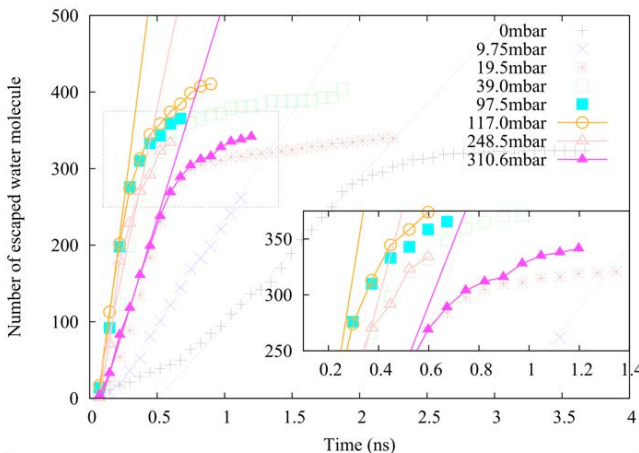

Dehydration curves of $MgSO_4 \cdot 7H_2O$ calculated from MD simulation

PROJECT LEADERS

CCM Rindt, SV Nedeá,
AA van Steenhoven

RESEARCH THEME

Complex dynamics of fluids

PARTICIPANTS

Eldhose Iype

COOPERATIONS

Dr. Markus Huetter (Asso. Prof.)
Department of Mechanical
Engineering, TU/e)

FUNDED

European Graduate School
University 100 %
FOM -
STW -
NWO Other -
Industry -
TNO -
GTI -
EU -
Scholarships -

START OF THE PROJECT

2009

INFORMATION

C Rindt
040 247 2978
C.C.M.Rindt@tue.nl

PROJECT LEADERS

AJH Frijns, DMJ Smeulders

RESEARCH THEME

Complex structures of fluids

PARTICIPANTS

M Sharma, FP Wieringa,
R Mandamparambil, JP Kooman

COOPERATIONS

TNO, MUMC+

FUNDED

Kidney Foundation
University -
FOM -
STW -
NWO Other -
Industry 100 %
TNO -
GTI -
EU -
Scholarships -

START OF THE PROJECT

2013

INFORMATION

A Frijns
040 247 4825
a.j.h.frijns@tue.nl
www.energy.tue.nl

PROJECT AIM

For microchannel gas flows, macroscopic models for heat transfer are not sufficient to describe the cooling mechanisms. Therefore particle-based models have to be used. The goal of this project is to study the convective heat transfer and evaporative cooling in micro-devices by Molecular Dynamics (MD) and Direct Simulation Monte Carlo (DSMC) techniques and to develop a multi-scale simulation method.

PROGRESS

Molecular dynamics simulations of heat transfer in gases are computationally expensive when the wall molecules are explicitly modeled. To save computational time, an implicit boundary function is often used. In this work, the conceptual idea of Steele's potential was extended in order to simulate water-silicon and water-silica interfaces. A new wall potential model is developed by using the electronegativity-equalization method (EEM), a ReaxFF empirical force field and a non-reactive molecular dynamics package PumMa. Contact angle simulations were performed in order to validate the wall potential model. The MD results are in agreement with experimental values.

DISSERTATIONS

-

SCIENTIFIC PUBLICATIONS

1. Kim, J., Frijns, A.J.H., Gaastra - Nedea, S.V. & Steenhoven, A.A. van (2013). Geometry effects on rarefied nanochannel flows. *Microfluidics and Nanofluidics*, 15(5), 661-673.

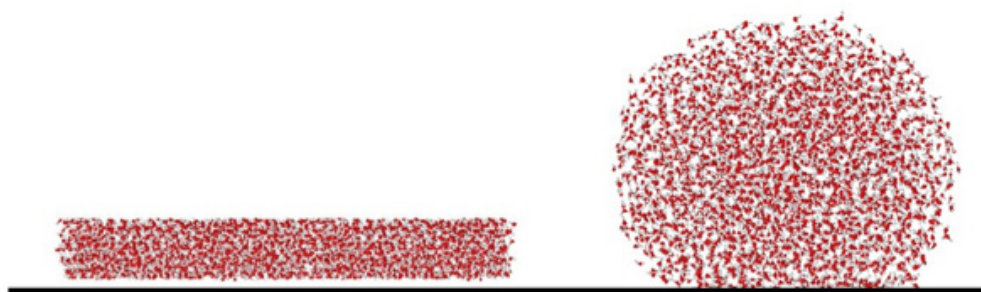

Initial and an equilibrated configuration of water molecules on top of a silicon wall

HEAT TRANSFER IN THE HUMAN BODY

PROJECT AIM

The goal of this project is to develop dynamic and human specific thermo-physiological model to predict the heat transfer and temperature distribution in the human body. The model will be used for medical applications and for the prediction of thermal comfort in the built environment.

PROGRESS

Our thermo-physiological model ThermoSEM is further improved by the introduction of a neurological based thermoregulation model. The new model outcomes are compared with experiments on volunteers. Good agreement is shown for blood flow, and for skin and core temperatures for young adults as well as for elderly. This thermo-physiological model was also used to predict the thermal responses to (changes in) the indoor climate. It was extended such that the thermal sensation can be predicted as well. Simulations and measurements showed a good agreement.

DISSERTATIONS

-

SCIENTIFIC PUBLICATIONS

1. Schellen, L., Loomans, M.G.L.C., Kingma, B.R.M., Wit, M.H. de, Frijns, A.J.H., Marken Lichtenbelt, W. van (2013). The use of a thermophysiological model in the built environment to predict thermal sensation : coupling with the indoor environment and thermal sensation. Building and Environment, 59, 10-22.

PROJECT LEADERS

AJH Frijns, AA van Steenhoven, DMJ Smeulders

RESEARCH THEME

Mathematical and computational methods for fluid flow analysis

PARTICIPANTS

BRM Kingma, C Jacquot, M te Culve, L Schellen, WD van Marken Lichtenbelt

COOPERATIONS

MUMC+

FUNDED

| | |
|--------------|-------|
| STW | |
| University | - |
| FOM | - |
| STW | 100 % |
| NWO Other | - |
| Industry | - |
| TNO | - |
| GTI | - |
| EU | - |
| Scholarships | - |

START OF THE PROJECT

1999

INFORMATION

A Frijns
040 247 4825
a.j.h.frijns@tue.nl
www.energy.tue.nl

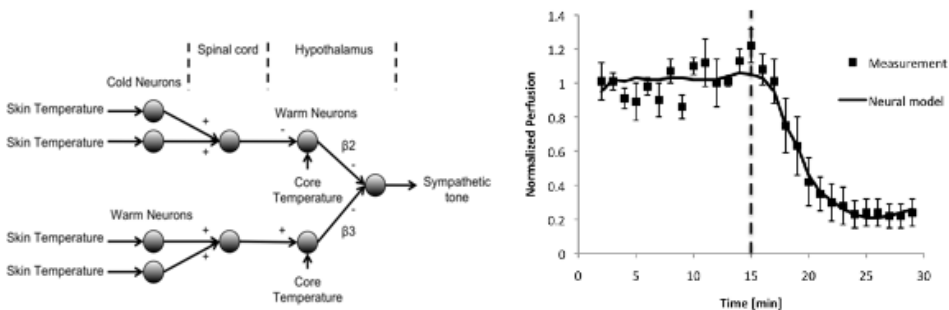

Neuro-physiological thermoregulation model(left) and measured and computed thermal sensation (right).



Prof.dr.ir. EH van Brummelen

The Multiscale Engineering Fluid Dynamics section of the Mechanical Engineering Department at TU Eindhoven has been established in 2009 within the framework of the 3TU Centre of Excellence for Multiscale Phenomena. The MEFD section focuses on the development, analysis and application of mathematical-physical models and advanced numerical techniques for multiscale flow problems in engineering applications, with particular emphasis on interface and free-boundary problems, flow problems in the transitional molecular/continuum regime and auxiliary field interactions, such as fluid-structure interaction. The research in the section has an underpinning and methodological character, while maintaining a strong connection to applications in the high-tech industry and in other sections at TU/e.

NUMERICAL SIMULATION OF DROP FORMATION AND DYNAMICS IN PICOLITER JETTING TECHNOLOGY

PROJECT AIM

This project aims at the development of a computational platform to simulate the ejection of liquid droplet in the 1 picoliter regime from a micro nozzle. On account of the very small scales, it is necessary to include the interaction of the droplet with the surrounding air and to ensure a very precise representation of surface/interface effects. This requirement calls for advanced moving-mesh techniques. In addition, contact-line effects must be properly included.

PROGRESS

The simulation model is based on the Cahn-Hilliard-Navier-Stokes diffuse-interface model for two phase flows. In subproject 1, numerical results have been obtained for the Cahn-Hilliard equations separately with special boundary conditions to model wetting behavior on solid substrates. Moreover, a baseline model for the CHNS equations has been implemented. Further investigation of the time-discretization procedure and the iterative method are required. In subproject 2, the main aspects of an adaptivity strategy have been formulated, to conduct adaptivity in a space/time setting based on rigorous a-posteriori error estimates.

DISSERTATIONS

-

SCIENTIFIC PUBLICATIONS

1. G. Simsek, K.G. van der Zee, and E.H. van Brummelen, Error estimation for the convective Cahn Hilliard equation, Adaptive Modeling and Simulation 2013 - Proceedings of the 6th International Conference on Adaptive Modeling and Simulation, ADMOS 2013, 2013, pp. 631-633.

PROJECT LEADERS

EH van Brummelen

RESEARCH THEME

Mathematical and computational methods for fluid flow analysis

PARTICIPANTS

M Shokrpour Roudbari, G Simsek, G van Zwieten, EH van Brummelen, HMA Wijshoff, KG van der Zee

COOPERATIONS

KG van der Zee (Univ Nottingham)

FUNDED

| | |
|------------------|------|
| NanoNextNL (FES) | |
| University | 25 % |
| FOM | - |
| STW | - |
| NWO Other | - |
| Industry | 75 % |
| TNO | - |
| GTI | - |
| EU | - |
| Scholarships | - |

START OF THE PROJECT

2011

INFORMATION

EH van Brummelen
040 2475470
e.h.v.brummelen@tue.nl
www.tue.nl/vanbrummelen

ADAPTIVE MOMENT-CLOSURE APPROXIMATIONS OF THE BOLTZMANN EQUATION

PROJECT LEADERS

EH van Brummelen

RESEARCH THEME

Mathematical and computational methods for fluid flow analysis

PARTICIPANTS

MRA Abdel Malik, EH van Brummelen

COOPERATIONS

M Torrilhon (RWTH Aachen)

FUNDED

| | |
|--------------|-------|
| TU/e | |
| University | 100 % |
| FOM | - |
| STW | - |
| NWO Other | - |
| Industry | - |
| TNO | - |
| GTI | - |
| EU | - |
| Scholarships | - |

START OF THE PROJECT

2011

INFORMATION

EH van Brummelen
040 2475470
e.h.v.brummelen@tue.nl
www.tue.nl/vanbrummelen

PROJECT AIM

The aim of this project is to create a paradigm for adaptive hierarchical moment-closure approximations of the Boltzmann equation.

PROGRESS

A new moment-closure hierarchy has been formulated, which preserves the fundamental structural properties of the Boltzmann equation (conservation of mass, momentum and energy; Galilean invariance; dissipation of an entropy functional; representation of equilibrium distributions), which yields finite fluxes in the vicinity equilibrium, and which facilitates the computation of fluxes. The baseline implementation of the Euler equations in moment form has been finalized. Implementation of higher-order systems is currently in progress.

DISSERTATIONS

-

SCIENTIFIC PUBLICATIONS

1. M. Abdel Malik and E.H. van Brummelen, Hierarchical moment closure approximation of the Boltzmann equation, Adaptive Modeling and Simulation 2013 - Proceedings of the 6th International Conference on Adaptive Modeling and Simulation, ADMOS 2013 (J.P. Moitinho de Almeida, P. Diez, C. Tiago, and N. Pares, eds.), no. 108, 2013, pp. 1–10.



Prof.dr.ir. JMJ den Toonder

Jaap den Toonder is full professor and Chair of the Microsystems group at the Eindhoven University of Technology.

Jaap den Toonder studied at the Delft University of Technology and got his Master's degree in Applied Mathematics in 1991 (cum laude). He received a PhD degree (cum laude) from the same university in 1996 on a numerical/theoretical and experimental study of drag reduction in turbulent flows by polymer additives. His advisor was professor Frans Nieuwstadt.

In 1995, he joined the Philips Research Laboratories in Eindhoven, The Netherlands, where he started working in the field of the mechanics of solid materials. He worked on a wide variety of applications, such as ceramic capacitors, optical storage systems, IC low-k materials, RF MEMS, soft electronics, biomedical devices, polymer MEMS, and micro-fluidics. In 2008, he became Chief Technologist, leading the R&D program on (micro-)fluidics, and (starting in 2011) materials science and engineering. He was involved in research programs on molecular diagnostics, lab-on-chip, immersion lithography, and energy applications. Next to his main job at Philips, Jaap den Toonder was a part-time professor at the Materials Technology group of the Eindhoven University of Technology between 2004 and 2013.

His current main research interests are:

- Micro-fluidics,
- Out-of-cleanroom micro-fabrication technologies
- Mechanical properties of biological cells and tissues
- Nature-inspired micro-actuators
- Organs on chips

Jaap den Toonder has (co-)authored over 70 scientific papers, as well as over 40 patent applications. He is a member of the Editorial Board of Lab on a Chip.

GAS SENSOR MEMBRANE

PROJECT AIM

The PASTEUR project aims to build a disposable tag for food monitoring. Our work focusses on a membrane that will be used to enhance the functionality of the micro-scale gas sensors. The membrane will block solid particles and droplets and remove them from the sensor surface while still allowing the target gas to be transported to the sensor. Additionally it will enhance both the sensitivity and selectivity of the sensor using a perm-selective membrane in combination with a pumping system.

PROGRESS

Experiments were carried out to modify a PDMS surface. By tuning the ablation parameters, we could make it sticky or slippery super-hydrophobic. These surfaces were characterized using SEM, Raman spectroscopy and static and dynamic contact angle measurements. We created a pattern that acted as a drop merger, drop size could be tuned by choosing the tilting angle. We also created a pattern that acted as a drop container. An oxygen concentration sensor was installed on the setup.

DISSERTATIONS

-

SCIENTIFIC PUBLICATIONS

-

PROJECT LEADERS

JMJ den Toonder, AJH Frijns

RESEARCH THEME

Complex structures of fluids

PARTICIPANTS

S van Pelt

COOPERATIONS

Holst Centre

FUNDED

CATRENE, PASTEUR

University -

FOM -

STW -

NWO Other -

Industry 100 %

TNO -

GTI -

EU -

Scholarships -

START OF THE PROJECT

2009

INFORMATION

S van Pelt

040 247 2186

s.v.pelt@tue.nl

www.tue.nl/en/university/departments/mechanical-engineering/research/research-groups/research-group-microsystems/research/microsystems-applications/gas-sensor-window/



PROJECT LEADERS

JMJ den Toonder, Y Bellouard

RESEARCH THEME

Complex structures of fluids

PARTICIPANTS

A Schaap

COOPERATIONS

Norwegian Water Research Institute

FUNDED

Eindhoven University of Technology,

Dept. Mechanical Engineering, EC

Project "Femtoprint" (FP7)

University 90 %

FOM -

STW -

NWO Other -

Industry 10 %

TNO -

GTI -

EU -

Scholarships -

START OF THE PROJECT

2010

INFORMATION

Yves Bellouard

040 247 3715

y.bellouard@tue.nl

tue.nl/microsystems

PROJECT AIM

The identification of algae species is useful and important for monitoring water quality and conditions for health and environmental applications. This project aims to develop a chip-based approach to identifying and classifying algae species in water in real-time, using microfluidics with integrated optical and/or other sensors. We use a femtosecond laser to create microchannels and optical waveguides in fused silica, to create integrated optofluidic microdevices on a single substrate.

PROGRESS

We've been experimenting with second-generation prototypes of our algae identification system. Specifically, we're using simulations and experiments of the interplay of optical and mechanical forces for pre-sorting algae, to complement the optical identification system already built. In a side project, we've been exploring the capabilities of our femtosecond laser fabrication system for 3D microsystems in general, and considering whether these capabilities could be used in further sensor development.

DISSERTATIONS

-

SCIENTIFIC PUBLICATIONS

1. Allison Schaap, Yves Bellouard, "Molding topologically-complex 3D polymer microstructures from femtosecond laser machined glass," Optics Materials Express, 9(3), 1428-1437, 2013.

3D polymer microstructures, molded from a glass substrate machined with a femtosecond laser

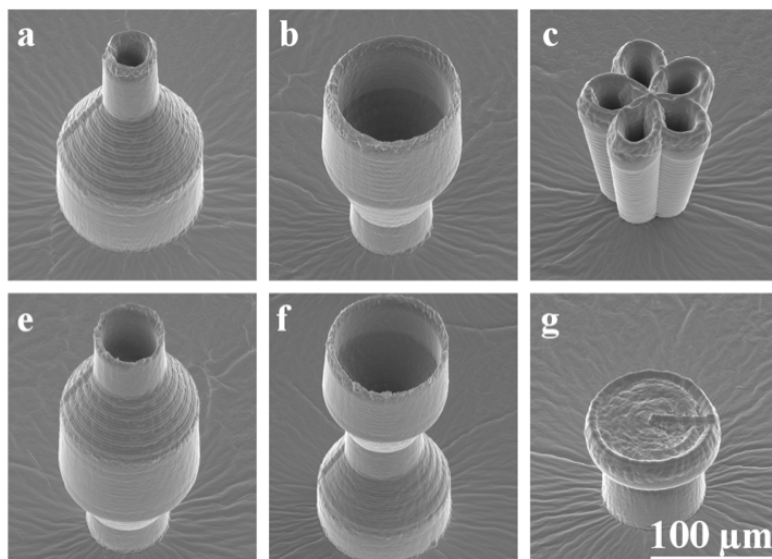

HETEROGENEOUS SENSOR SYSTEMS ON FOIL

PROJECT AIM

Develop basic functions and manufacturing processes for realizing fluidic based sweat sensing micro systems which combine the strengths of foil and Si technology.

PROGRESS

1. Inspired by the water transportation system in plants, a prototype of an evaporation driven pump for water on foil was fabricated by laser ablation and lamination;

2. The pump was analyzed with evaporation theory describing an array of evaporating droplets; the pumping rate was measured by 2D-PTV; the pumping rate can be adjusted by number, size and pitch of pore structure at the evaporation end;

3. Integration of pump with silicon chip is possible by using ACF (Anisotropic Conductive Foil).

DISSERTATIONS

-

SCIENTIFIC PUBLICATIONS

1. C. Nie, R. Mandamparambil, A. Frijns and J.M.J. den Toonder "An Evaporation Driven Capillary Pump on a Flexible Substrate", Poster presentation in MicroNano Conference 2013, Ede, the Netherlands.

PROJECTLEADERS

JMJ den Toonder, AJH Frijns

RESEARCHTHEME

Complex structures of fluids

PARTICIPANTS

C Nie, A Frijns, R Mandamparambil

COOPERATIONS

Holst Centre, Eindhoven

FUNDED

| | |
|--------------|-------|
| University | - |
| FOM | - |
| STW | - |
| NWO Other | - |
| Industry | - |
| TNO | 100 % |
| GTI | - |
| EU | - |
| Scholarships | - |

START OF THE PROJECT

2011

INFORMATION

C Nie
040 247 3647
c.nie@tue.nl
www.tue.nl/universiteit/faculteiten/
faculteit-werktuigbouwkunde/
onderzoek/research-groups/
microsystems/research/
microsystems-applications/chuan/

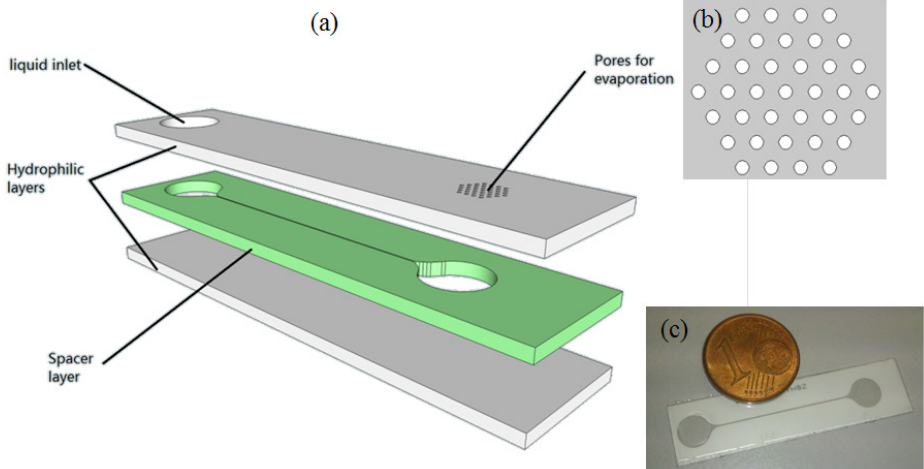

Figure 1 (a) Sandwiched structures of a simple device fabricated by lasers; White/Grey: hydrophilized PET; Green: double side adhesive coated PET. (b) Pores array at the evaporation end; (c) Real sample.

ON-FOIL LARGE-SCALE INTEGRATION AND PACKAGING OF SENSOR FOILS

PROJECT LEADERS

JMJ den Toonder, ECP Smits,
A Dietzel

RESEARCH THEME

Complex dynamics of fluids

PARTICIPANTS

G Arutinov

COOPERATIONS

Holst Centre/TNO; BEAMS Group,
Free University of Brussels

FUNDED

Eindhoven University of Technology
and TNO

University 50 %

FOM -

STW -

NWO Other -

Industry -

TNO 50 %

GTI -

EU -

Scholarships -

START OF THE PROJECT

2010

INFORMATION

G Arutinov

040 247 2186

G.Arutinov@tue.nl

PROJECT AIM

The project aims to develop the technique based on effective use of capillary self-alignment for low-cost and time-efficient assembly of heterogeneous foil components into a smart electronic identification label. Particularly, we demonstrate the accurate (better than 20 μm) alignment of c sized functional foil dies.

PROGRESS

We investigated the role played by the assembly liquid, by the size and the weight of assembling dies and by their initial offsets in the self-alignment performance. It was shown that there is a definite range of initial offsets allowing dies to align with high accuracy and within approximately the same time window, irrespective of their initial offset. We experimentally evidenced three sequential, distinct dynamic regimes in the capillary self-alignment of centimeter-sized foil dies released at large uniaxial offsets from equilibrium. We show that the initial transient wetting regime, along with inertia and wetting properties of the dies, significantly affect the alignment dynamics including the subsequent constant acceleration and damped oscillatory regimes.

DISSERTATIONS

-

SCIENTIFIC PUBLICATIONS

1. G. Arutinov, M. Mastrangeli, E. C. P. Smits, H. F. M. Schoo, J. Brugger, A. Dietzel, Appl. Phys. Lett. 2013, 102, 144101.

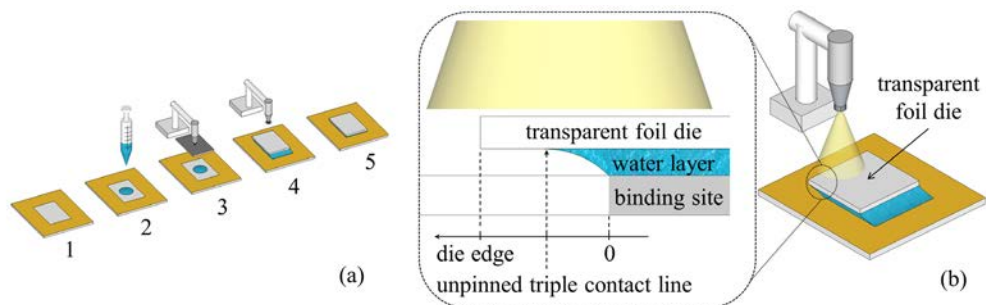

(a) Process steps for capillary SA of a foil die: (1) patterning of the carrier substrate, (2) deposition of water droplet, (3) coarse die pre-alignment, (4) die release and meniscus formation, (5) die self-alignment on binding site. (b) Concurrent high-speed tracking of uniaxial lateral capillary SA and water triple contact line dynamics (see Fig. 4). The camera was focused on the outer edge of the transparent foil die (not to scale).

CANCER METASTASIS-ON-A-CHIP

PROJECT AIM

The aim is to realize micro-fluidics technologies that can be used to create an in-vitro model for cancer metastasis and to study (real time) cancer metastasis from a primary tumor to a secondary site as happens in the human body.

PROGRESS

The project started in September 2013. After reviewing the literature in the first few months, a conceptual design of the chip has been made. In this design, the device consists of three layers: a top layer containing micro-chambers used to culture tumor cells as well as organ cells that are potential sites for metastasis, a bottom layer with a micro-channel network that models the blood vasculature, and finally a porous membrane which is the barrier between the tumor/organ and the blood vessel. The past two months have been devoted to implementation of a highly porous membrane between the two layers.

DISSERTATIONS

-

SCIENTIFIC PUBLICATIONS

-

PROJECTLEADERS

JMJ den Toonder

RESEARCHTHEME

Complex structures of fluids

PARTICIPANTS

HE Amirabadi, R Lüttge,

J den Toonder

COOPERATIONS

Phillips Research, Erasmus Medical Centre

FUNDED

| | |
|--------------|-------|
| STW | |
| University | - |
| FOM | - |
| STW | 100 % |
| NWO Other | - |
| Industry | - |
| TNO | - |
| GTI | - |
| EU | - |
| Scholarships | - |

START OF THE PROJECT

2013

INFORMATION

JMJ den Toonder

040 247 5706

j.m.j.d.toonder@tue.nl

www.tue.nl/microsystems

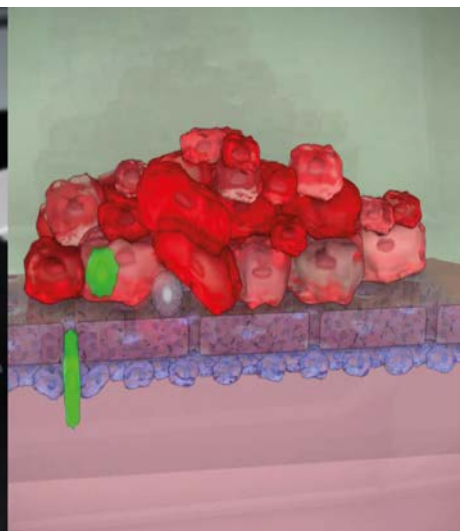
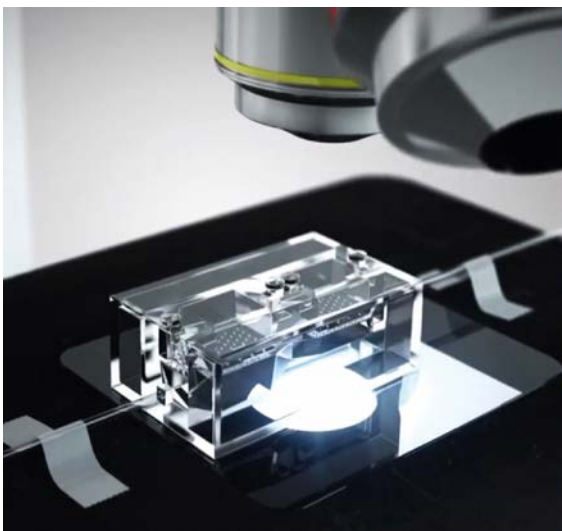

PROJECT LEADERS

R Luttge, JMJ den Toonder

RESEARCH THEME

Complex structures of fluids

PARTICIPANTS

B Schurink, PhD student University of Twente, S. Xie, PhD student University of Twente, A.J. Bastiaens, PhD student, Eindhoven, University of Technology

COOPERATIONS

prof. dr. J.G.E. Gardeniers, Mesoscale Chemical Systems, MESA+ Institute for Nanotechnology, University of Twente

FUNDED

European Research Council, ERC, no.280281 MESOTAS

| | |
|--------------|-------|
| University | - |
| FOM | - |
| STW | - |
| NWO Other | - |
| Industry | - |
| TNO | - |
| GTI | - |
| EU | 100 % |
| Scholarships | - |

START OF THE PROJECT

2011

INFORMATION

R Luttge
040 247 5235
r.luttge@tue.nl
www.tue.nl/en/university/
departments/mechanical-
engineering/the-department/staff/
detail/ep/e/d/ep-uid/20135203/

PROJECT AIM

Our aim is to combine microfluidics with tissue engineering to create a 'living' brain, generating realistic in vitro neural circuitry, which can be used to standardize experimental neuronal cell culture. For this, an on-chip bioreactor is fabricated to reproduce the natural 3D neuronal network of the brain in an easy-to-use in vitro setting. Nanotools are designed to guide neurite outgrowth and biomechanically stimulate this neuronal network. To study brain physiology, these two research fields are combined to biochemically and biomechanically stimulate the neuronal network. In the end, our platform can serve as a model to study and treat the brain disease epilepsy.

PROGRESS

A 3D bioreactor of PDMS is developed, with an integrated hydrogel barrier, separating the culture chamber from the medium channel. This barrier sustains the transport of oxygen and nutrients and avoids a direct effect of the shear stress on the cell culture. Rat cortical cells could be cultured up to 6 days with preserved viability. Various sized nanoscaffolds (NS) were created by Jet and Flash Imprint Lithography. NS with a period between 400 nm and 600 nm and a height of 118 nm shows highly ordered regions of neurites, with a preferential alignment tendency for astrocytes. The stiffness of the scaffold has a significant effect on the number of neuronal cells attached and on the direction of their outgrowths. Both nanopatterned Si and PDMS guide the outgrowth of astrocytes, but astrocytes tend to form more outgrowths on the softer PDMS than on the harder Si. Astrocytes thus 'sense' the NS stiffness, which might have a profound effect on the neuronal network formed.

DISSERTATIONS

-

SCIENTIFIC PUBLICATIONS

- Schurink B, Luttge R. A hydrogel/PDMS hybrid bioreactor facilitating 3D cell culturing. *J Vac Sci Technol* (2013) B 31, 06F903; <http://dx.doi.org/10.1116/1.4831762>.
- Xie S, Luttge R. Jet and Flash Imprint Lithography provides topographical nanocues to guide cell growth in primary cortical cell culture. *MNE* 2013 (under review).
- Schoeman RM, Kemna EW, Wolbers F, van den Berg A. High-throughput deterministic single cell encapsulation and droplet pairing, fusion and shrinkage in a single microfluidic device. *Electrophoresis* (2013) doi: 10.1002/elps.
- Kemna EWM, Segerink LI, Wolbers F, Vermes I, van den Berg A. Label-free, high-throughput, electrical detection of cells in droplets. *Analyst* (2013) 138(16):4585-92; doi: 10.1039/c3an00569k.
- Griep LM, Wolbers F, de Wagenaar B, ter Braak PM, Weksler BB, Romero IA, Couraud PO, Vermes I, van der Meer AD, van den Berg A. BBB on chip: microfluidic platform to mechanically and biochemically modulate blood-brain barrier function. *Biomed Microdev* (2013) 15(1):145-50; doi 10.1007/s10544-012-9699-7.

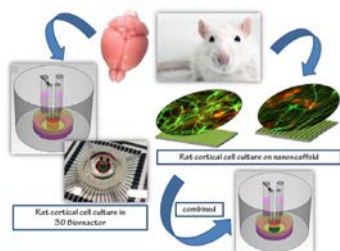

DYNACLEAN: DYNAMIC SELF-CLEANING SURFACES

PROJECT AIM

The goal of this work is to create dynamic self-cleaning surfaces, switchable between self-cleaning and non-cleaning by means of an external trigger.

PROGRESS

Our first approach is to create microscopic base structures (3 – 40 μm) in SU-8, after which a stimulus-responsive (e.g. heat, light, pH) hydrogel is placed within the remaining voids. An initial fabrication of the first approach has been completed. Optimization of the manufacturing process, behaviour of the hydrogel for different stimuli and the self-cleaning properties of the first approach are still to be investigated.

DISSERTATIONS

-

SCIENTIFIC PUBLICATIONS

-

PROJECT LEADERS

J den Toonder (TU/e), D Broer (TU/e), P Onck (RUG)

RESEARCH THEME

Complex dynamics of fluids

PARTICIPANTS

GG Melpignano, E de Jong

COOPERATIONS

Phillips, DSM

FUNDED

| | |
|--------------|-------|
| STW | - |
| University | - |
| FOM | - |
| STW | 100 % |
| NWO Other | - |
| Industry | - |
| TNO | - |
| GTI | - |
| EU | - |
| Scholarships | - |

START OF THE PROJECT

2013

INFORMATION

G Melpignano
040 247 4905
g.g.melpignano@tue.nl
www.tue.nl/en/university/
departments/mechanical-
engineering/research/
research-groups/research-group-
microsystems/research/active-
control-in-micro-fluidics/dynaclean/

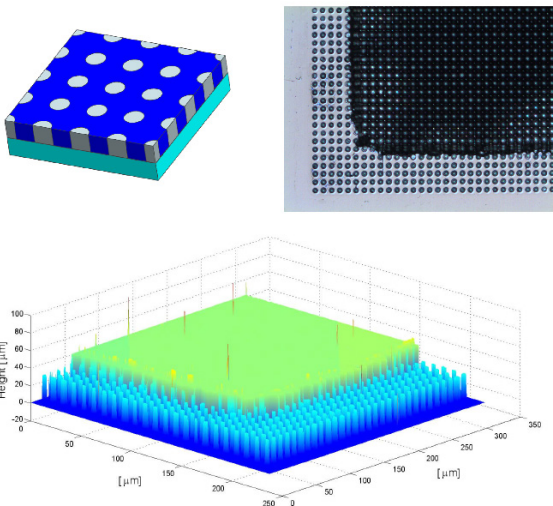



Prof.dr.ir. FN van de Vosse

The Cardiovascular Biomechanics group at the department of Biomedical Engineering aims to promote the use of experimentally validated predictive mathematical modeling, both in diagnosis and selection of therapy in clinical practice as well as in research and development in the medical device industry. The research in the group is divided in 4 areas of which the first is embedded in JMBC.

1. HEMODYNAMICS

Hemodynamic factors such as like local pressure, velocity, wall shear stress and wall deformation are crucial for the proper functioning of the vascular system, the heart and its native valves. These factors play a key role in the genesis of vascular disease and, when measured properly, can also be predictive for the development of cardiovascular disease. Hemodynamics research in the group is focused on the development of mathematical models and the corresponding computational methods based on finite and spectral element approximations. These models are used to understand the functioning and response of the cardiovascular system. The models range from 0D lumped parameter and 1D wave propagation models of the entire cardiovascular system to 3D models of local fluid-structure interaction in specific arterial segments and heart valve dynamics. Both microscopic (blood as a suspension) as well as macroscopic (blood-wall interaction) scales are considered. In vitro laboratory experiments and measurement techniques are designed and used to validate the outcome of the computational simulations.

2. MECHANICS AND ADAPTATION

Cardiovascular mechanics research is focused on the understanding of the mechanical response of vascular and cardiac tissue to mechanical loads, caused by the pulse wave propagation and cardiac contraction, as well as external forces caused by medical interventions.

3. INSTRUMENTATION AND DEVICES

Medical instrumentation and devices like ultrasound image modalities, pressure and flow sensors, particularly those used for advanced diagnostic measurements.

4. CLINICAL RESEARCH

Through pilot or full clinical studies, in which patient data are gathered and used as input for patient specific modelling, evaluation of the predictive value of mathematical models to predict outcome of medical intervention can be performed.

RHEOLOGY OF BLOOD CLOT FORMATION

PROJECT AIM

Blood clots form upon vascular injury in order to prevent blood loss and are involved in the process of wound healing. The structure of the blood clot plays a role in many pathologies and is influenced by the flow conditions under which the clot develops. However, the relation between structural properties influenced by the flow and the macroscopic mechanical properties of the clot is poorly understood. In this project constitutive equations are developed based on the structural properties of the different constituents of the clot to study its mechanical properties under various conditions.

PROGRESS

The main structural component of the blood clot is fibrin, a protein that forms a fibrous structure within the blood clot. A constitutive model is developed that describes the formation of the fibrin network in time. The network formation is modeled as a transition from a viscous fluid to a viscoelastic solid, where the transition is governed by the fibrin kinetics. The model is extended to describe the non-linear viscoelastic properties of the network that are important for its physiological functioning. Rheometry experiments are performed in which a fibrin network is formed within the rheometer. Furthermore, experiments are performed in which the complexity of the probed sample is increased towards whole blood, to ultimately model blood clot formation based on its main components.

DISSERTATIONS

-

SCIENTIFIC PUBLICATIONS

-

PROJECT LEADERS

FN van de Vosse, GWM Peters

RESEARCH THEME

Complex structures of fluids

PARTICIPANTS

THS van Kempen

COOPERATIONS

TU/e Mechanical Engineering

TU/e Applied Physics

FUNDED

TU/e High Potential Research

Program: Blood in Motion

University 100 %

FOM -

STW -

NWO Other -

Industry -

TNO -

GTI -

EU -

Scholarships -

START OF THE PROJECT

2011

INFORMATION

THS van Kempen

t.h.s.v.kempen@tue.nl

Plotting the strain versus stress in a so-called Lissajous plot illustrates the time-dependent, non-linear viscoelastic properties of a fibrin network.

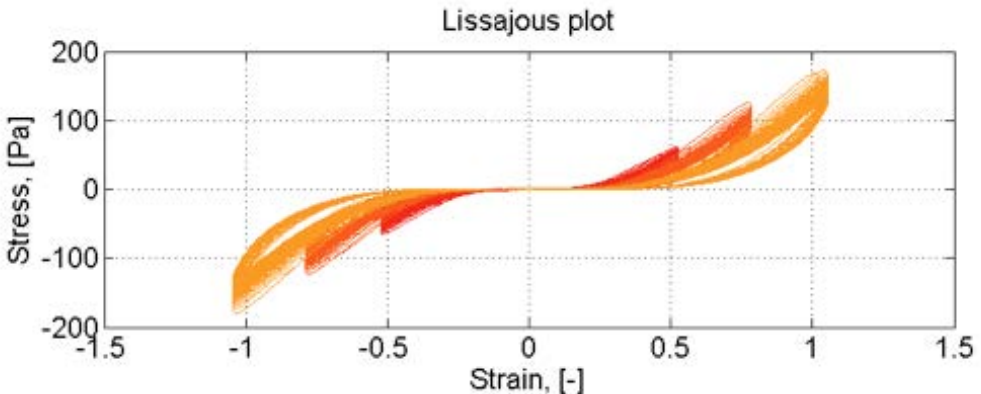

CONTINUUM MODELLING OF BLOOD CLOT FORMATION AND GROWTH

PROJECT LEADERS

FN van de Vosse

RESEARCH THEME

Complex dynamics of fluids

PARTICIPANTS

F Storti

COOPERATIONS

TU/e Mechanical Engineering

TU/e Applied Physics

FUNDED

TU/e High Potential Research

Program: Blood in Motion

University 100 %

FOM -

STW -

NWO Other -

Industry -

TNO -

GTI -

EU -

Scholarships -

START OF THE PROJECT

2010

INFORMATION

F Storti

f.storti@tue.nl

PROJECT AIM

Hemostasis is the complex process necessary to prevent blood loss. It involves the interplay between biochemical and physical processes, which normally keep the blood in a fluidic state and repair the walls of veins and arteries in case of injury. When this happens a blood clot forms around the injury. The phenomenon of blood clotting mainly consists of two mechanisms:

1. dynamics of platelet and chemical species;
2. clot growth and remodelling.

The aim of the project is to create a mathematical model that describes the blood clot formation and growth. Particular attention is given to the interaction between the blood flow and the porous clot.

PROGRESS

The initial formation of the clot is modelled through a biochemical model, i.e. a system of convection-diffusion-reaction equations. Unactivated platelets, activated platelets, chemical activators and chemical inhibitors are modelled as concentrations. All these factors represent the onset of the coagulation process. The main outcome of the biochemical model, i.e. the concentration of bounded platelets at the injury site, defines the clot area. The clot is represented by means of an elastic solid, which interacts with the flow around it through a sequential FSI scheme. Practically, the finite element method is used to solve the equations, a mesh update scheme represents the clot growth and once in a while remeshing is also necessary. All convection-diffusion-reaction equations are in the ALE form.

DISSERTATIONS

-

SCIENTIFIC PUBLICATIONS

1. Storti, F., van Kempen, T.H.S. and van de Vosse, F.N., A continuum model for platelet plug formation and growth under flow, 3rd International Conference on Computational and Mathematical Biomedical Engineering - CMBE2013 16-18 December 2013, Hong-Kong.
2. Storti, F., van Kempen, T.H.S. and van de Vosse, F.N. (2014), A continuum model for platelet plug formation and growth. Int. J. Numer. Meth. Biomed. Engng.. doi: 10.1002/cnm.2623.

Left: platelet deposition at injury site when taking plug growth into account (red line) and when neglecting it (black line). Right: platelet plug growth at different times with velocity field visualization.

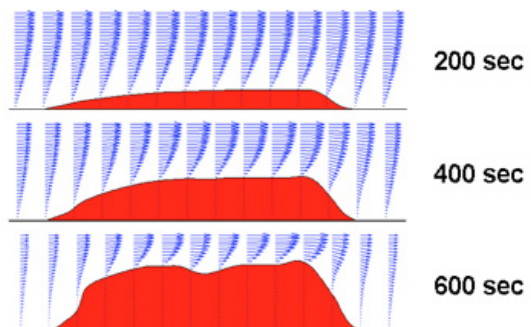
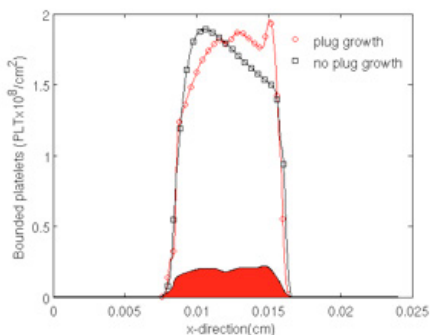

PROBING RED BLOOD CELL MECHANICS

PROJECT AIM

Because of the high volume contents of red blood cells (RBCs) in blood, mechanics of a single RBC plays a large role in plasma mixing and lateral transport of its components. Therefore, a characterization of the dynamical parameters of RBCs under different flow conditions is needed. Our strategy involves estimation of mechanical properties of the RBC using an inverse analysis which combines both numerical and experimental tools. A RBC is deformed under elongational flow. Advantage of this experimental method is that there is no contact between a solid and the cell membrane, which would complicate the analysis, especially during dynamic deformations. To create a setup with elongational flow, a cross-slot microfluidics device is built (left figure). Rigid channels in SU-8 photoresist on glass are sealed with a PDMS foil. The foil also serves as a deflecting membrane for the valves, which enable position control of the cell. Piezo-electric elements are used in closed loop control to actuate the valves. To change the stress on the RBC dynamically, a pulsatile microfluidics pump is designed, built, and tested.

PROGRESS

In the current work, a device is developed that can serve as a pulsatile flow pump for a microfluidic rheometer, in which complex micromaterial behavior (microgels, cells, elastic capsules,) can be investigated. The micro-rheometer is based on a cross-slot setup, which consists of a microfluidic chip with crossing channels, a metering valve, and a feedback system. With the cross-slot setup, in which elongational flow exists, such as in the four roll mill, a particle or droplet in unsteady flow can be captured. For that purpose, a pump that drives pulsatile flows with a frequency of tens of Hz, and amplitudes down to 10 nl/s, is required. Although publications about micro-pumps are abundant, to our knowledge no data of instantaneous flows (i.e. concerning waveforms) at these scales have been published. The resulting microscale flows have been measured with high temporal resolution micro particle image velocimetry (-PIV) using a fluorescence microscope, equipped with a high speed video camera. Results of steady, oscillatory, and pulsatile flow are presented, as well as passive and active noise responses.

DISSERTATIONS

-

SCIENTIFIC PUBLICATIONS

-

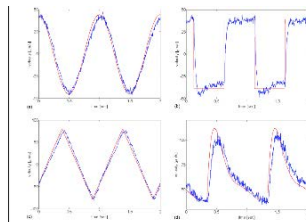
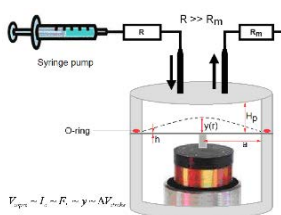

PROJECTLEADERS

FN van de Vosse, ACB Bogaerds, PD Anderson

RESEARCHTHEME

Complex dynamics of fluids

PARTICIPANTS

RCH van der Burgt

COOPERATIONS

TU/e Mechanical Engineering

TU/e Applied Physics

FUNDED

TU/e High Potential Research

Program: Blood in Motion

University 100 %

FOM -

STW -

NWO Other -

Industry -

TNO -

GTI -

EU -

Scholarships -

START OF THE PROJECT

2009

INFORMATION

R van der Burgt

r.c.h.v.d.burgt@tue.nl

Left: Schematic overview of the pulsatile pump setup developed, where a syringe pump is put in series with a diaphragm pump to produce a pulsatile flow. A voice coil deflects a stainless steel membrane (with radius $a = 6.5$ mm, and thickness $h = 200\mu\text{m}$) into a chamber of height H_p . By making the hydraulic resistance upstream of the diaphragm pump, R , much larger than the resistance of the measurement channel downstream, R_m , the flow pulse will mainly travel downstream. Right: Plots of four different fluid velocity waves: (a) oscillatory sinusoidal flow, (b) square wave flow, (c) triangular flow, (d) flow as a result of a physiological blood pressure curve as input. The time derivative of the input signals are shown in red, which should be comparable to the diaphragm velocity and hence, proportional to the stroke volume swept by the diaphragm. The measured flows approach the red curves to a reasonable extent.

PROJECTLEADERS

FN van de Vosse, MA Hulsen

RESEARCHTHEME

Mathematical and computational methods for fluid flow analysis

PARTICIPANTS

AC Verkaik

COOPERATIONS

TU/e Mechanical Engineering

FUNDED

| | |
|--------------|-------|
| TU/e | |
| University | 100 % |
| FOM | - |
| STW | - |
| NWO Other | - |
| Industry | - |
| TNO | - |
| GTI | - |
| EU | - |
| Scholarships | - |

START OF THE PROJECT

2008

INFORMATION

AC Verkaik
A.C.Verkaik@tue.nl

PROJECT AIM

Distal to artificial heart valves transitional (transition to turbulence) flow with small scale local velocity fluctuations can be found. To compute transitional flow spectral elements can be used, however we also want to compute accurately the fluid stress near the deforming structure. Therefore, this study will focus on the implementation of a coupling method between spectral and finite elements to compute fluid-structure interaction for transitional flow through artificial heart valves.

PROGRESS

In previous periods we proposed an overlapping domain technique to couple the fixed grid fluid domain with an Arbitrary Lagrangian Eulerian (ALE) moving grid fluid domain. This allows for an optimal conformal coupling between the fluid elements and the structural elements.

First, the convergence of the spectral elements was proved. Next the fluid-fluid coupling of the overlapping domain technique has been investigated by using the flow around a cylinder benchmark problem. Also transitional flow computations were performed for flow through an orifice with $Re=1000$. Based on these test results an article has been submitted. Currently, the performance of the overlapping domain technique for a fluid-structure interaction benchmark problem is investigated (see the figure below).

DISSERTATIONS

-

SCIENTIFIC PUBLICATIONS

1. A.C. Verkaik, M.A. Hulsen, A.C.B. Bogaerds and F.N. van de Vosse, Coupled overlapping domain method for fluid-structure interaction, Colloquium on Immersed Boundary Methods, Leiden, the Netherlands, 2013.
2. A.C. Verkaik, M.A. Hulsen, A.C.B. Bogaerds and F.N. van de Vosse, An overlapping domain technique coupling spectral and finite elements for fluid-structure interaction, submitted, 2013.

The velocity and vorticity of flow around a fixed cylinder with an attached elastic beam ($Re=200$) computed with an overlapping domain technique combining finite element ALE techniques with a spectral element background.

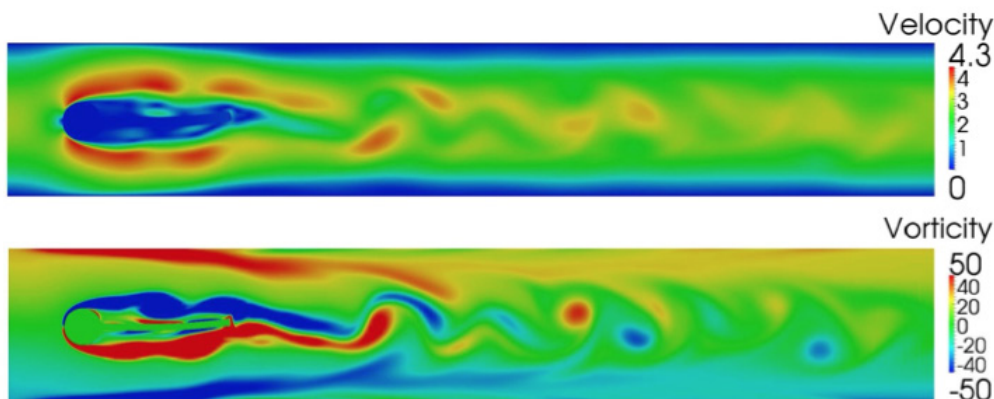

CENTRE FOR ANALYSIS, SCIENTIFIC COMPUTING AND APPLICATIONS (CASA)



Prof.dr.ir. B Koren



Prof.dr. WHA Schilders



Prof.dr. F Toschi



Prof.dr.ir. CJ van Duijn



Prof.dr. MA Peletier



Prof.dr. IS Pop



Prof.dr. JJM Slot

TU/e's Centre for Analysis, Scientific Computing and Applications (CASA) embodies the chairs Applied Analysis and Scientific Computing, which both participate in the J.M. Burgerscentrum.

CASA's research objective is to develop new and improve existing mathematical methods - both analytical and numerical - for a wide range of applications in science and engineering. Extensive collaborations exist with researchers in other disciplines, at universities, large technological institutes as well as industries, both nationally and internationally. Current CASA research related to fluid dynamics concerns aerodynamics, aeroacoustics, magnetohydrodynamics, fluid-structure interactions, porous media flows, viscous and viscoelastic flows, free-surface flows, particle flows and shape optimization.

PROJECT AIM

The project mainly concerns the mathematical modelling of sound absorbing lining material (physically correct descriptions in time domain; thermo-viscous effects of liners consisting of stacked pores; the coupling with an unstable boundary layer). The modelling of the effect of the boundaries on the sound produced by the flow is also the key topic of research.

PROGRESS

Non linear impedance model of a Helmholtz resonator: This work encompass the mathematical modelling of a Helmholtz resonator in the non-linear regime. Analytically obtained from first principles, are systematic asymptotic expressions for the velocity and pressure yielding explicit expressions for the corresponding impedance. The results compare favourably with the known models and experimental data. Scattering of sound by turbulence in shear flow along a wall passing a hard-soft transition: This work presents a canonical model for the vorticity scattering in incompressible turbulent flow with linear shear as it passes, hard to soft wall transition. The boundary near field (inner) solution obtained from Weiner Hopf technique is matched to the far-field to obtain the far-field sound pressure level.

DISSERTATIONS

-

SCIENTIFIC PUBLICATIONS

1. A Systematic Impedance Model for Non-Linear Helmholtz Resonator Liner, AIAA 2013-2223, 19th AIAA/CEAS Aeroacoustics Conference, 27-29 May 2013, Berlin, Germany, 2013.

PROJECTLEADERS

S Rienstra, JMM Slot

RESEARCHTHEME

Mathematical and computational methods for fluid flow analysis

PARTICIPANTS

DK Singh

COOPERATIONS

Acoustics Laboratory of the Université du Maine

FUNDED

| | |
|------------------|-------|
| Marie Curie (EU) | |
| University | - |
| FOM | - |
| STW | - |
| NWO Other | - |
| Industry | - |
| TNO | - |
| GTI | - |
| EU | 100 % |
| Scholarships | - |

START OF THE PROJECT

2012

INFORMATION

DkR Singh
040 247 5865
d.k.singh@tue.nl
<http://www.win.tue.nl/~sjoerdr/>

MODELING, ANALYSIS AND SIMULATION IN MULTISCALE PEDESTRIAN FLOWS

PROJECT LEADERS

A Muntean, MA Peletier

RESEARCH THEME

Complex dynamics of fluids

PARTICIPANTS

JHM Evers

COOPERATIONS

AV Lyulin (Eindhoven), AAF van de

Ven (Eindhoven), SC Hille (Leiden)

RC Fetecau (Burnaby, Canada)

FUNDED

NWO Graduate Programme 2010

University -

FOM -

STW -

NWO Other 100 %

Industry -

TNO -

GTI -

EU -

Scholarships -

START OF THE PROJECT

2011

INFORMATION

A Muntean

040 247 2702

a.muntean@tue.nl

PROJECT AIM

The research aims at studying a two-scale model for the behaviour of a crowd of pedestrians, in which micro and macro views are combined. Inspiration is taken from measure theory, continuum mechanics and thermodynamics. The research covers a new direction within both the Department of Mathematics and Computer Science, and the Institute for Complex Molecular Systems. Nevertheless, it fits very well in the philosophy of the ICMS (multi-disciplinarity, complexity). Also, it matches with the new trend towards a more theoretical understanding (in terms of measures) of particle systems and their continuum limits, driven by MA Peletier and his group.

PROGRESS

We published a paper coauthored by L Gulikers and AV Lyulin on the simulation of anisotropies in microscopic crowd dynamics, based on L Gulikers' bachelor's thesis. Work with AAF van de Ven was presented and published in the context of a conference in Paris. Improved and extended results are in preparation. Together with SC Hille (Leiden) we worked on better mathematical understanding (and analysis) of suitable boundary conditions. A first publication appeared in the beginning of 2014, communicating the main result of a larger paper currently under review. There is work in preparation with RC Fetecau (SFU, Burnaby). We made plans for a two months' visit of JHM Evers to Burnaby in the beginning of 2014.

DISSERTATIONS

-

SCIENTIFIC PUBLICATIONS

1. L. Gulikers, J.H.M. Evers, A. Muntean and A.V. Lyulin. "The effect of perception anisotropy on particle systems describing pedestrian flows in corridors". Journal of Statistical Mechanics: Theory and Experiment, P04025 (2013).

SOUND PROPAGATION IN A DUCT WITH SHEARED FLOW AND NON-LOCALLY REACTING LINERS

PROJECT AIM

The goal of the project is to further develop and make available a class of semi-analytical solutions (based on modes) for the propagation and attenuation of sound in flow ducts, aiming in particular to the reduction of noise from the auxiliary power unit (APU, a turbine engine) of aircraft. Here, the walls of the duct are covered with acoustically damping material, i.c. non-locally reacting liners (e.g. metallic foam). Furthermore, the mean flow exhibits strong shear and temperature gradients. Keywords: duct acoustics, aeroacoustics.

PROGRESS

The development of a new code based on a modal representation of the acoustic field has been continued. The code handles a segmented duct with non-locally reacting impedance walls, non-uniform mean flow and non-uniform temperature, where each segment has different impedance properties. The combined effect of multiple segments is computed by using the mode-matching approach, which is based on setting up a system of equations for the modal amplitudes at each interface between two segments. The matrix entries are usually computed by numerically evaluating standard integral inner products, which is expensive and less accurate. The development and implementation of a new method, based on integrals of Pridmore-Brown modes which can be evaluated in closed form, has been continued. These integrals can replace the standard inner products, which makes the new method cheaper and more accurate.

DISSERTATIONS

-

SCIENTIFIC PUBLICATIONS

1. M. Oppeneer, S. W. Rienstra, and P. Sijtsma. "Efficient Mode-Matching Based on Closed Form Integrals of Pridmore-Brown Modes". In: Proceedings of the 19th AIAA/CEAS Aeroacoustics Conference, Berlin, Germany. AIAA 2013-2172. May 2013.

PROJECTLEADERS

SW Rienstra, P Sijtsma,
RMM Mattheij

RESEARCHTHEME

Mathematical and computational
methods for fluid flow analysis

PARTICIPANTS

P Sijtsma (supervisor NLR), SW
Rienstra (supervisor), RMM Mattheij
(promotor), M Oppeneer (PhD-
student)

COOPERATIONS

Airbus

FUNDED

National Aerospace Laboratory NLR
University -
FOM -
STW -
NWO Other -
Industry -
TNO -
GTI 100 %
EU -
Scholarships -

START OF THE PROJECT

2009

INFORMATION

SW Rienstra
040 247 4603
s.w.rienstra@tue.nl

DEVELOPMENT OF A COMPUTATIONAL TOOL FOR THE SIMULATION OF WIND-FARM AERODYNAMICS

PROJECT LEADERS

B Koren

RESEARCH THEME

Mathematical and computational methods for fluid flow analysis

PARTICIPANTS

B Sanderse

COOPERATIONS

Energy research Centre of the Netherlands (ECN)

FUNDED

ECN

University -

FOM -

STW -

NWO Other -

Industry 100 %

TNO -

GTI -

EU -

Scholarships -

START OF THE PROJECT

2008

INFORMATION

B Sanderse

020 592 4161

bsanderse@gmail.com

PROJECT AIM

The Dutch government plans that a significant portion of the Dutch future energy need is to be produced by wind farms at the North Sea. A wind farm is a large set of wind turbines, often positioned in some matrix form. Various research questions still exist with respect to wind farms; economical, ecological and technological. A major technological question is how to position and design the separate wind turbines, such that the energy production of the wind farm as a whole is maximal. The goal of this project is to make a step towards answering this question.

PROGRESS

The PhD dissertation has been finished and has been successfully defended (cum laude) in March 2013. Several articles have been published (see below). A software tool for simulating the 3D turbulent incompressible Navier-Stokes equations on staggered grids with wind turbines represented by actuator disks has been developed: Energy-Conserving Navier-Stokes solver (ECNS). The prototype code is written in Matlab, a parallelized version is available in Fortran. The inclusion of turbulence models will be done in a next PhD project.

DISSERTATIONS

1. B. Sanderse, Energy-conserving discretization methods for the incompressible Navier-Stokes equations - Application to the simulation of wind-turbine wakes, TU Eindhoven, March 19, 2013, (promotor: prof.dr.ir. B. Koren).

SCIENTIFIC PUBLICATIONS

1. B. Sanderse. Energy-conserving Runge-Kutta methods for the incompressible Navier-Stokes equations. Journal of Computational Physics, 233:100–131, 2013.

CHALLENGES IN SMOOTHED PARTICLE HYDRODYNAMICS

PROJECT AIM

SPH is a gridless, particle based technique and is especially suited for treating problems with free surfaces, multiphase flows, high velocity impacts, crack propagation or large deformations. It has been applied with great success in many fields in engineering and science. However, there are still great challenges ahead, e.g. to achieve reliable and accurate solutions, the computational accuracy, consistency, stability and convergence need further study. Also the treatment of domain boundaries and imposing boundary conditions has triggered attention, but has not been dealt with properly yet.

PROGRESS

Approximations in SPH generally suffer from the presence of boundaries. During the last year approximations for the one-dimensional second derivative and the two-dimensional Laplacian were developed and tested. The results showed much higher accuracy than with traditional approximations, especially close to domain boundaries. In some cases SPH also suffers from unphysical particle clustering. During the last year two methods that avoid or reduce the clustering of particles were investigated. The methods showed promising results, but to really tackle the problem of particle clustering more research is required.

DISSERTATIONS

-

SCIENTIFIC PUBLICATIONS

1. Korzilius S.P., Schilders W.H.A., Anthonissen M.J.H. (2013); An improved corrective smoothed particle method approximation for second order derivatives. 8th International SPHERIC Workshop, Trondheim (Norway), June 2013.

PROJECT LEADERS

WHA Schilders, MJH Anthonissen

RESEARCH THEME

Mathematical and computational methods for fluid flow analysis

PARTICIPANTS

SP Korzilius

COOPERATIONS

-

FUNDED

| | |
|--------------|-------|
| University | - |
| FOM | - |
| STW | - |
| NWO Other | 100 % |
| Industry | - |
| TNO | - |
| GTI | - |
| EU | - |
| Scholarships | - |

START OF THE PROJECT

2012

INFORMATION

SP Korzilius
040 247 3987
s.p.korzilius@tue.nl

CONTROL AND MITIGATION OF EDGE LOCALIZED MODES BY FURTHER DEVELOPMENT AND APPLICATION OF COMPUTATIONAL TOOLS

PROJECT LEADERS

B Koren, HJ de Blank

RESEARCH THEME

Mathematical and computational methods for fluid flow analysis

PARTICIPANTS

B van Es

COOPERATIONS

FOM-DIFFER, CWI

FUNDED

FOM (FOM Program 120, "Active Control of Magnetic Hydrodynamic Modes in Burning Plasmas")

| | |
|--------------|-------|
| University | - |
| FOM | 100 % |
| STW | - |
| NWO Other | - |
| Industry | - |
| TNO | - |
| GTI | - |
| EU | - |
| Scholarships | - |

START OF THE PROJECT

2011

INFORMATION

B van Es

020 592 4166

b.van.es@cw.nl

PROJECT AIM

Edge Localized Modes (ELMs) are disruptive magnetohydrodynamic (MHD) instabilities observed in torus-shaped fusion devices in which an extremely hot plasma is confined magnetically (tokamaks) for the eventual goal of energy production. The project aim is to find ways to control and mitigate ELMs in an early stage of their development.

PROGRESS

General methods and finite difference and finite volume discretisation methods for extreme anisotropic diffusion were developed. The methods were tested on various discriminating benchmark problems.

DISSERTATIONS

-

SCIENTIFIC PUBLICATIONS

1. Es, B. van, Koren, B. & Blank, H.J. de (2013). Finite-Difference Methods for Extremely Anisotropic Diffusion. Chapter in Advanced Numerical Methods for Complex Environmental Models: Needs and Availability. DOI: 10.2174/97816080577881130101, Pages: 29-52.

OPTIMAL OFFSHORE WIND FARMS (OPTIWIND)

PROJECT AIM

To develop a design algorithm for optimal wind farms based on state-of-the-art computational methods for solving the Navier-Stokes equations for turbulent wind-farm-wake flow and inverse problems.

PROGRESS

The candidate did literature review on methods for solving the incompressible Navier-Stokes equations, focusing mainly on the finite-volume methods. A new method for computing the interface velocities in the finite-volume method for the incompressible Navier-Stokes was also developed.

DISSERTATIONS

-

SCIENTIFIC PUBLICATIONS

-

PROJECTLEADERS

JHM ten Thije Boonkamp, ME
Hochstenbach, B Koren

RESEARCHTHEME

Mathematical and computational methods for fluid flow analysis

PARTICIPANTS

N Kumar

COOPERATIONS

-

FUNDED

| | |
|--------------|-------|
| University | - |
| FOM | 100 % |
| STW | - |
| NWO Other | - |
| Industry | - |
| TNO | - |
| GTI | - |
| EU | - |
| Scholarships | - |

START OF THE PROJECT

2013

INFORMATION

B Koren
040 247 2080
b.koren@tue.nl
[www.tue.nl/en/employee/ep/e/d/
ep-uid/20120036/](http://www.tue.nl/en/employee/ep/e/d/ep-uid/20120036/)

CONSTITUTIVE MODELING OF CONCENTRATED SOLUTIONS OF MAIN-CHAIN LIQUID CRYSTALLINE POLYMERS

PROJECT LEADERS

JJM Slot

RESEARCH THEME

Complex dynamics of fluids

PARTICIPANTS

O Matveichuk

COOPERATIONS

Prof. dr. J. Molenaar (WUR),

Prof. dr. S. Picken (TUD),

Teijin Aramid R&D

FUNDED

Teijin-Aramid BV

University -

FOM -

STW -

NWO Other -

Industry 100 %

TNO -

GTI -

EU -

Scholarships -

START OF THE PROJECT

2008

INFORMATION

JJM Slot

040 247 4381

j.j.m.slot@tue.nl

PROJECT AIM

The primary objective of this project is to develop a molecularly based constitutive model for the rheological behavior of concentrated solutions of main-chain liquid crystalline polymers (LCP) that may show nematic order. The model will be restricted to monodomain (single director) morphologies and the main focus will be on the role that chain flexibility plays in this behavior.

PROGRESS

Thesis was finalized.

DISSERTATIONS

1. Constitutive modeling of concentrated solutions of main-chain liquid crystalline polymers. Defense took place on March 11, 2013.

SCIENTIFIC PUBLICATIONS

-

COMPARISON BETWEEN HYPERVELOCITY IMPACT OF PARTICLES AND PULSED LASER THERMAL IMPACT MODELS ON GLUE BONDED LAMINATES UNDER CRYOGENIC CONDITIONS

PROJECT AIM

The final goal of this project is to study Hypervelocity Impacts into laminated materials. For that purpose we intend to extend the capabilities of the Smoothed Particle Hydrodynamics numerical method, modify existing algorithms and create a computational tool.

PROGRESS

Smoothed Particle Hydrodynamics (SPH) numerical technique has proven to be an efficient method to study Hypervelocity Impacts (HVIs). However, two problems have been recognised. Firstly, not all SPH schemes used in the literature of HVIs conserve momentum or energy. New, improved SPH schemes for HVIs, have been derived from a procedure based on Lagrange's variational principle, encountered in SPH algorithms used for astrophysical problems. The framework is extended in order to include material models and dissipative processes (e.g. plasticity). Secondly, the ability of the derived schemes to resolve shock waves through inhomogeneous structures. It is tested by a series of one-dimensional tests. Numerical diffusion is used to dampen out oscillations in the shock region and we introduce a new artificial mass flux term that enhances the scheme's ability for shock capturing. Two-dimensional problems are set up with a new code.

DISSERTATIONS

-

SCIENTIFIC PUBLICATIONS

1. I.Zisis, B.Linden, C.Giannopapa; Towards a Smoothed Particle Hydrodynamics algorithm for shocks through layered materials; Proceedings of the 2013 ASME Pressure Vessels & Piping Conference PVP-2013 July 14-18, 2013, Paris, France.
2. I.Zisis, B.Linden; Shock loading of layered materials with SPH; 8th International SPHERIC workshop, Trondheim, Norway, June 4-6, 2013.

PROJECTLEADERS

B Koren

RESEARCHTHEME

Mathematical and computational methods for fluid flow analysis

PARTICIPANTS

I Zisis, BJ van der Linden

COOPERATIONS

-

FUNDED

Materials innovation institute M2i and Laboratory for Industrial Mathematics Eindhoven LIME bv.

University -

FOM -

STW -

NWO Other -

Industry 100 %

TNO -

GTI -

EU -

Scholarships -

START OF THE PROJECT

2011

INFORMATION

I Zisis

i.zisis@tue.nl

POROFLOW: MATHEMATICAL AND NUMERICAL ANALYSIS OF NON-EQUILIBRIUM EFFECTS IN POROUS MEDIA FLOWS

PROJECT LEADERS

CJ van Duijn

RESEARCH THEME

Mathematical and computational methods for fluid flow analysis

PARTICIPANTS

X Cao, CJ van Duijn, IS Pop, S Nemadjieu

COOPERATIONS

Prof. dr. L.A. Peletier (Leiden)
Prof. dr.ir. S.M. Hassanizadeh (Utrecht), Dr. P.A. Zegeling (Utrecht)
Prof. dr.ir. R. Helmig (Stuttgart)
Prof. dr. C. Rohde (Stuttgart)
Prof. dr. F.A. Radu (Bergen)
Dr. C. Cances (Paris)
Dr. M. Vohralik (Paris)

FUNDED

| | |
|---------------------------|-------|
| China Scholarship Council | |
| University | - |
| FOM | - |
| STW | - |
| NWO Other | - |
| Industry | - |
| TNO | - |
| GTI | - |
| EU | - |
| Scholarships | 100 % |

START OF THE PROJECT

2011

INFORMATION

S Pop
040 247 5516
i.pop@tue.nl
<http://www.win.tue.nl/~pop>

PROJECT AIM

In this work non-classical mathematical models for flows in porous media are considered. Specifically, the relationship between the quantities of primary interest (like the capillary pressure, or the saturation) are including terms accounting for the non-equilibrium effects. The research will address aspects related to the mathematical modelling, analysis and numerics for such models. In particular, heterogeneous media are being considered, and appropriate coupling conditions between two homogeneous blocks are derived.

PROGRESS

In this year, we analyzed the well-posedness (the existence of a solution) of a mathematical model for two-phase porous media flow, a system coupling a nonlinear, possibly degenerate parabolic equation and an elliptic one. A code for the finite volume discretization and its analysis are under development. Furthermore, appropriate coupling conditions at the interface separating two homogeneous blocks are derived. This includes a possible discontinuity in the capillary pressure, extending the results available for equilibrium models.

DISSERTATIONS

-

SCIENTIFIC PUBLICATIONS

1. C.J. van Duijn, I.S. Pop, Shock waves and two phase porous media flows, *Nieuw Arch. Wiskd.* (5), Vol. 14 (2013), pp. 207-211.
2. C.J. van Duijn, Y. Fan, L.A. Peletier, I.S. Pop, Travelling wave solutions for degenerate pseudo-parabolic equation modelling two-phase flow in porous media, *Nonlinear Anal. Real World Appl.*, Vol. 14 (2013), pp. 1361-1383.
3. Y. Fan, I.S. Pop, Equivalent formulations and numerical schemes for a class of pseudo-parabolic equations, *J. Comput. Appl. Math.*, Vol. 246 (2013), pp. 86-93.
4. C.J. van Duijn, S.M. Hassanizadeh, I.S. Pop, P.A. Zegeling, Non-equilibrium Models for Two Phase Flow in Porous Media: the Occurrence of Saturation Overshoots, in ICAPM 2013, Proceedings of the 5th International Conference on Applications of Porous Media, Cluj University Press, 2013, pp. 59-70.

CONSTITUTIVE MODELING OF ARBITRARY BRANCHED POLYMER MELTS

PROJECT AIM

The primary objective of this project is to develop a molecularly based constitutive model for the rheological behavior of polymer melts consisting of arbitrary branched polymer molecules. An industrially relevant example of such a system is a melt of low-density polyethylene (LdPE). As such a system shows an extreme variation in molecular composition, a description of this composition can only be given in statistical terms. Hence, the idea is to describe such a system by a finite set (ensemble) of representative molecular structures (topologies). This part of work on kinetic modeling is done at the University of Amsterdam in a twin PhD project (not part of the JMBC).

PROGRESS

In 2013 we have focused on the modification of the time-marching algorithm (TMA) (van Ruymbeke et al., 2005, 2010) for predicting the linear viscoelasticity of polymer melts consisting of well described molecules: monodisperse stars, asymmetric stars, symmetric h-polymers and their blends. For the case of symmetric stars, we validated the TMA model and, for the first time, compared it to the so-called BoB model (Das et al., 2006). The predictions obtained with the two models are compared for a large set of experimental data, which cover a broad range of arm molecular weights (from 1.5 to 55 entanglements per arm) of different chemistries (polystyrene, polybutadiene and polyisoprene). Validation of the TMA model for the case of symmetric h-polymers and blends of the stars, linears and h-polymers was also done with the help of a large set of experimental data. One paper is submitted to Macromolecules, another paper is in preparation.

DISSERTATIONS

-

SCIENTIFIC PUBLICATIONS

-

PROJECT LEADERS

JJM Slot

RESEARCH THEME

Complex dynamics of fluids

PARTICIPANTS

V Shchetnikava

COOPERATIONS

Prof. dr. ir. E. van Ruymbeke, UCL, Belgium, Prof. dr. P.D. Iedema, UvA

FUNDED

Dutch Polymer Institute (DPI)

University -

FOM -

STW -

NWO Other 100 %

Industry -

TNO -

GTI -

EU -

Scholarships -

START OF THE PROJECT

2009

INFORMATION

JJM Slot

040 247 4381

jj.m.slot@tue.nl



Prof.dr.ir. JAM Kuipers



Prof.dr.ir. M van Sint Annaland

The research group SMR participates amongst others in the OSPT and the JMBC for fluid mechanics and focuses on fundamentals of the discipline of chemical reaction engineering. Our main area of interest is the quantitative description of transport phenomena (including fluid flow) and the interplay with chemical transformations in multiphase chemical reactors. The generation of new knowledge and the development of new reactor models with improved predictive capability for this industrially important class of chemical reactors constitutes an important goal of our research activities. Through the intended co-operation with other (application oriented) research groups, both fundamental aspects and those closely related to applications will be studied through concerted action. The main research topics of the new group SMR can be divided into the following three areas: Multiphase Reactors, Advanced Experimental Techniques and Novel Reactors, which will be discussed below in more detail.

An important area of attention is the development of advanced reactor models for multiphase reactors with industrial relevance. At present our research focuses on the hydrodynamics in these reactors because it is generally recognized that the lack of understanding of the flow phenomena is one of the central difficulties in the design and scale-up of multiphase reactors. In the near future the interplay of flow phenomena with chemical reactions will be studied in great detail. We use various types of CFD models (both commercial codes but mostly "in house" made codes) to study the relevant hydrodynamic phenomena at all relevant length and time scales (i.e. at the microscopic, mesoscopic and macroscopic scale). In our group both multifluid models are being developed and models which treat the dispersed phase (particles, bubbles or droplets) in a discrete manner accounting for possible encounters between the dispersed elements.

The second important area of our research deals with the development of advanced experimental techniques to measure key quantities (i.e. local volume fractions and velocities of the dispersed and continuous phase). As an example we can mention the development of the digital particle image velocimetry technique to measure in a non-intrusive manner the velocity map of both the liquid phase and dispersed gas bubbles in (dense) gas-liquid dispersions. This type of flow very often arises in a variety of gas-liquid contactors/reactors. In this area we co-operate with specialists within the J.M. Burgerscentrum for fluid mechanics. Of course this research activity is intimately connected to the first research topic. Our third important area of research deals with the development of novel (multiphase) reactors with emphasis on integration and intensification of relevant process steps. As an example we can mention here the Rapid Reaction Cycling Reverse Flow (RRCRF) which integrates (in a thermal sense) endothermic and exothermic heterogeneously catalyzed chemical reactions where the endothermic reaction causes rapid (reversible) catalyst deactivation. These types of chemical reaction systems often arise in practice for instance in the production of lower alkenes from the corresponding alkanes via heterogeneously catalyzed dehydrogenation. The knowledge and tools developed within the other two areas of attention provide a sound basis to place this research activity on a firm footing.

CHARACTERIZATION OF THE FLUID DYNAMICS AND DISCRETE PARTICLE MODELLING OF A NOVEL SPOUTED BED APPARATUS

PROJECT AIM

To develop a spouted bed reactor for material which are difficult to fluidised and investigate the influence of operating parameters on bed dynamics under dry and wet conditions by considering heat and mass transfer effects.

PROGRESS

Spout fluidized beds are often utilized in number of applications granulation, coating and polymerization. During these operations a small amount of liquid is atomized through the nozzle to form granules via. particles-droplets collisions followed by a fast drying to prevent unnecessary liquid absorption inside the particle. However, small change in the liquid injection often results in a poor bed performance due local defluidization. In this work we present experiments performed in a pseudo 2D spout fluidized bed ($W \times D \times H = 0.08 \times 0.018 \times 0.15 \text{ m}^3$) to investigate the effect of liquid injection on the bed dynamics using high speed visual and infrared cameras.

DISSERTATIONS

-

SCIENTIFIC PUBLICATIONS

1. Sutkar, V.S., Deen, N.G. & Kuipers, J.A.M. (2013). Spout fluidized beds : recent advances in experimental and numerical studies. *Chemical Engineering Science*, 86, 124-136.
2. Sutkar, V.S., Deen, N.G., Mohan, B., Salikov, V., Antonyuk, S., Heinrich, S. & Kuipers, J.A.M. (2013). Numerical investigations of a pseudo-2D spout fluidized bed with draft plates using a scaled discrete particle model. *Chemical Engineering Science*, 104, 790-807.
3. Sutkar, V.S., Hunsel, T.J.K. van, Deen, N.G., Salikov, V., Antonyuk, S., Heinrich, S. & Kuipers, J.A.M. (2013). Experimental investigations of a pseudo 2D spout fluidized bed with draft plates. *Chemical Engineering Science*, 102, 524-543.

PROJECT LEADERS

JAM Kuipers

RESEARCH THEME

Mathematical and computational methods for fluid flow analysis

PARTICIPANTS

NG Deen, VS Sutkar

COOPERATIONS

Prof. S. Heinrich., Dr. S. Antonyuk
Hamburg University of Technology,
Germany

FUNDED

| | |
|--------------|-------|
| STW & DFG | |
| University | - |
| FOM | - |
| STW | 100 % |
| NWO Other | - |
| Industry | - |
| TNO | - |
| GTI | - |
| EU | - |
| Scholarships | - |

START OF THE PROJECT

2010

INFORMATION

JAM Kuipers
040 247 4158
J.A.M.Kuipers@TUE.nl
www.chem.tue.nl/smr

MODIFICATION OF KINETIC THEORY FOR GRANULAR FLOW BY INCLUDING FRICTION

PROJECT LEADERS

JAM Kuipers

RESEARCH THEME

Mathematical and computational methods for fluid flow analysis

PARTICIPANTS

L Yang, JT Padding

COOPERATIONS

-

FUNDED

ERC

University -

FOM -

STW -

NWO Other -

Industry -

TNO -

GTI -

EU 100 %

Scholarships -

START OF THE PROJECT

2013

INFORMATION

L Yang

040 247 8023

l.yang@tue.nl

PROJECT AIM

The aim of this project is to modify the current KTGF by including rotational velocity and particle-particle friction. This can give more insight into the hydrodynamics of granular flows in industrial size reactors. Then we incorporate the effect of friction between the particles in our current in house two-fluid model code, and at a later stage in the multi-fluid model. Validation of the modified KTGF model will follow from a comparison with the DPM model, in which friction can be modeled with reasonable accuracy, and also by comparing with one-to-one experiments.

PROGRESS

Currently, we have tried to derive our own KTGF which includes rotational velocity and friction. The continuity equations of mass, momentum and energy have been derived. We take the interaction of torque into consideration. However, about the derivation, there are still some parameters that we have to get, like thermal conductivity and viscosity. We will work them out later on.

DISSERTATIONS

-

SCIENTIFIC PUBLICATIONS

-

PROJECT AIM

The projects aims to prepare a computational model based on an Euler-Lagrange approach to simulate a bubble column with a wire-mesh inside it. The effect of the wires will be to cut bubbles into smaller pieces and thereby enhance the mass transfer in the column. The liquid phase flow patterns may shift towards plug flow kind of behavior leading to reduced back-mixing. The presence of catalyst coated wires will also be modeled by specifying reaction zone along wires.

PROGRESS

Liquid hydrodynamics has been modeled and verified first without presence of bubbles. After that bubbles were introduced. Bubble cutting through wires was achieved by a self developed bubble cutting algorithm. Test cases to verify the algorithm were successful. Thereafter the effect of various parameters such as mesh pitch, gas superficial velocity etc., were studied. A new hybrid VOF-DBM model taking into account the free surface in the column has also been proposed. Currently the impact of breakup and coalescence parameters is being studied with this model.

DISSERTATIONS

-

SCIENTIFIC PUBLICATIONS

- Jain, D., Lau, Y. M., Kuipers, J. A. M., & Deen, N. G. (2013). Discrete bubble modeling for a micro-structured bubble column. Chemical Engineering Science,100, 496-505.

PROJECTLEADERS

NG Deen

RESEARCHTHEME

Mathematical and computational methods for fluid flow analysis

PARTICIPANTS

D Jain, JAM Kuipers

COOPERATIONS

-

FUNDED

European Research Council
 University -
 FOM -
 STW -
 NWO Other -
 Industry
 TNO -
 GTI -
 EU 100 %
 Scholarships -

START OF THE PROJECT

2011

INFORMATION

NG Deen
 040 247 3681
 040 247 4931
 N.G.Deen@TUE.nl
 www.tue.nl/staff/N.G.Deen

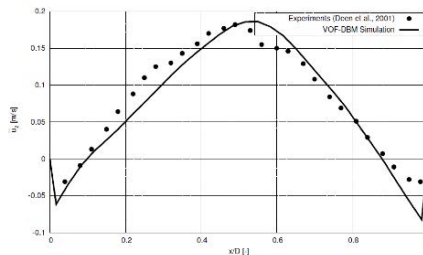
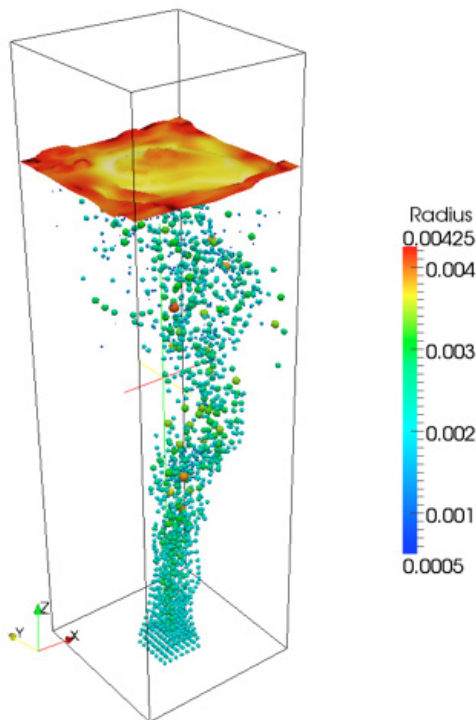

Comparison of simulated and experimental time averaged liquid vertical velocity profiles at a height of $z/H=0.56$ and a depth of $y/W=0.5$

CUTTING BUBBLES, MICRO-SCALE INTERACTION MASS AND HEAT TRANSFER

PROJECT LEADERS

NG Deen, JAM Kuipers

RESEARCH THEME

Mathematical and computational methods for fluid flow analysis

PARTICIPANTS

QIE Segers

COOPERATIONS

-

FUNDED

EU (ERC Starting Investigator Grant 259521)

University -

FOM -

STW -

NWO Other -

Industry -

TNO -

GTI -

EU 100 %

Scholarships -

START OF THE PROJECT

2010

INFORMATION

NG Deen

040 247 3681

N.G.Deen@tue.nl

www.chem.tue.nl/smr

PROJECT AIM

A proper test system is selected based on simulation and measurement with dyes in bubbly flows with and without wires. Measurement of heat and mass transfer rate as function of wire mesh layout and bubble mesh distance in a flat bubble column.

PROGRESS

A fully-implicit Immersed Boundary Method (IBM) has been applied to flows past a wire mesh section. From these simulations a more accurate prediction of the hydrodynamic drag has been formulated in the shape of a correlation. This correlation is directly used in coarser simulations not solving for the flow in micro-scale namely the Discrete Bubble Method (DBM). The work continues predicting heat transfer for the same type of flows. A paper on this topic is in the making. An experiment is simultaneously developed to verify the simulation results.

DISSERTATIONS

-

SCIENTIFIC PUBLICATIONS

1. Segers, Q.I.E., Deen, N.G. & Kuipers, J.A.M. (2012). Bubbly flow through a static wire mesh. Proceedings of the 22nd International Symposium on Chemical Reaction and Engineering (ISCRE 2012), 2-5 September 2012, Maastricht, The Netherlands.
2. Segers, Q.I.E., Kuipers, J.A.M. & Deen, N.G. (2013). Immersed Boundary Method applied to single phase flow past crossing cylinders. Chemical Engineering Science, 100, 33-38. in Web of Science Cited 1 times.
3. Segers, Q.I.E., Kuipers, J.A.M. & Deen, N.G. (2013). Immersed boundary method applied to single phase flow past crossing cylinders. Proceedings 11th International Conference on Gas-Liquid & Gas-Liquid-Solid Reactor Engineering, 19-22 August 2013, Seoul, South Korea.

THE EFFECT OF AIR ON SAND NEAR THE JAMMING POINT

PROJECT AIM

The aim of the current work is to investigate the intruder behaviour in a prefluidized granular bed, both from simulations and experiments, to obtain the force law and compare with literature results and to fully understand the viscosity of the idealized system obtained by different methods.

PROGRESS

The impact of a large sphere dropping into a prefluidized granular bed was numerically studied using a state-of-the-art hybrid Discrete Particle and Immersed Boundary Method (DP-IBM). The simulation results match well with existing experimental observations. This work revealed the importance of the interstitial gas and it also shows that the current simulation scheme could become a powerful tool to investigate the effect of interstitial gas on the dynamics of projectile impact cratering. An intruder moving with constant velocity through a prefluidized granular bed was also investigated and results show good agreement with the existing experimental work. For the model system which was designed to check the validity of Stokes' law and also the viscosity in an idealized granular fluid with well-controlled density and granular temperature, the dropping ball method, the Couette flow method and also Green-Kubo method were employed.

DISSERTATIONS

-

SCIENTIFIC PUBLICATIONS

1. Y. Xu, J. Padding, M. van der Hoef, J. Kuipers, Detailed numerical simulation of an intruder impacting on a granular bed using a hybrid discrete particle and immersed boundary (DP-IB) method. *Chemical Engineering Science*, 104 (2013) 201-207.

PROJECT LEADERS

JAM Kuipers

RESEARCH THEME

Mathematical and computational methods for fluid flow analysis

PARTICIPANTS

Y Xu, JT Padding, MA van der Hoef

COOPERATIONS

-

FUNDED

| | |
|--------------|-------|
| FOM | |
| University | - |
| FOM | 100 % |
| STW | - |
| NWO Other | - |
| Industry | - |
| TNO | - |
| GTI | - |
| EU | - |
| Scholarships | - |

START OF THE PROJECT

2011

INFORMATION

JAM Kuipers
040 247 4158
J.A.M.Kuipers@tue.nl
www.chem.tue.nl/smr

PROJECT LEADERS

JAM Kuipers

RESEARCH THEME

Mathematical and computational methods for fluid flow analysis

PARTICIPANTS

JT Padding, EAJFPeters, Chauvik De

COOPERATIONS

Dr. Albert Janssen- SHELL

FUNDED

| | |
|--------------|-------|
| FOM | |
| University | - |
| FOM | 100 % |
| STW | - |
| NWO Other | - |
| Industry | - |
| TNO | - |
| GTI | - |
| EU | - |
| Scholarships | - |

START OF THE PROJECT

2013

INFORMATION

JAM Kuipers
040 247 4158
j.a.m.kuipers@tue.nl

PROJECT AIM

Polymer liquids are used in the oil industry to improve the volumetric sweep efficiency and displacement efficiency of the oil from a reservoir. Surprisingly, it is not only the viscosity but also the elastic properties of the displacing fluid that determine the displacement efficiency. This may be caused by the ability of a viscoelastic fluid to pull oil out of dead-ends. The objective of the project is to develop a computer simulation methodology for the flow of non-Newtonian fluids through porous media. This will enable us to gain a fundamental understanding of the effects of fluid elasticity and interfacial tension between the oil phase and the displacing fluid on the recovery efficiencies.

PROGRESS

To understand the flow of polymers through a porous media and explain the viscoelastic effects the non linear viscoelastic models (Advanced Maxwell based) are required. Thus different constitutive model equations present in literature has been analytically solved, and compared with the experimental dataset from Shell and literature data to select the most suitable rheological model. The proper constitutive model will be incorporated in a CFD based code to determine the flow characteristics. So the development of CFD based code is in progress. Also model microchannel based experiments are planned to visualise the flow of non newtonian fluids through micro PIV experiments. This will provide fundamental insights and help to validate the code.

DISSERTATIONS

-

SCIENTIFIC PUBLICATIONS

-

CUTTING BUBBLES. THE COALESCENCE AND BREAK-UP OF BUBBLES ON MICRO SCALE

PROJECT AIM

Bubbles that rise in a bubble column have the tendency to coalesce. This reduces the interfacial area with respect to the volume of the gas. To reduce the loss of interfacial area, a wired mesh is introduced in the column. This mesh will introduce the break-up of bubbles. In this research, the effect of the coalescence and break-up of the model due to the wired mesh is studied using Direct Numerical Simulations. The results of the simulations will be validated using clean experiments. The experiments will be performed in well defined environments for increasingly complex wire configurations.

PROGRESS

The surface tension modelling in the Volume of Fluid have been improved using the tensile force method. This new surface tension method was compared to the CSF model of Brackbill and the often used height function model. Furthermore, the implementation of the first order immersed boundary method has been improved by replacing the solid body approach with a numerical integration of the velocity inside the particle as was suggested before by Kempe et al (2012). This will enable us to simulate neutrally buoyant particles.

DISSERTATIONS

-

SCIENTIFIC PUBLICATIONS

1. Baltussen, M.W., Seelen, L.J.H., Kuipers, J.A.M. and Deen, N.G., Direct Numerical Simulations of gas-liquid-solid three phase flows, Chemical Engineering Science, 100 (2013), 293-299.

PROJECT LEADERS

NG Deen, JAM Kuipers

RESEARCH THEME

Mathematical and computational methods for fluid flow analysis

PARTICIPANTS

MW Baltussen

COOPERATIONS

-

FUNDED

| | |
|---------------------------|-------|
| European Research Council | |
| University | - |
| FOM | - |
| STW | - |
| NWO Other | - |
| Industry | - |
| TNO | - |
| GTI | - |
| EU | 100 % |
| Scholarships | - |

START OF THE PROJECT

2011

INFORMATION

JAM Kuipers

040 247 4158

J.A.M.Kuipers@TUE.nl

www.chem.tue.nl/smr

MULTISCALE MODELING OF GAS-SOLID MASS TRANSFER AND ITS IMPACT ON RISER REACTOR PERFORMANCE

PROJECT LEADERS

A Carlos Varas

RESEARCH THEME

Complex dynamics of fluids

PARTICIPANTS

A Carlos Varas, EAJF Peters,
JAM Kuipers

COOPERATIONS

-

FUNDED

NWO

University -

FOM -

STW -

NWO Other 100 %

Industry -

TNO -

GTI -

EU -

Scholarships -

START OF THE PROJECT

2013

INFORMATION

A Carlos Varas

06 198 04533

a.e.carlos.varas@tue.nl

[https://venus.tue.nl/ep-cgi/ep_detail.](https://venus.tue.nl/ep-cgi/ep_detail.opl?taal=US&fac_id=96&voor_org_id=&m=20100924)

[opl?taal=US&fac_id=96&voor_org_](https://venus.tue.nl/ep-cgi/ep_detail.opl?taal=US&fac_id=96&voor_org_id=&m=20100924)

[id=&m=20100924](https://venus.tue.nl/ep-cgi/ep_detail.opl?taal=US&fac_id=96&voor_org_id=&m=20100924)

PROJECT AIM

Insight into mass transfer inside riser reactors will be gained by means of a combined computational / experimental study. The focus will be on the influence of particle clusters on mass transfer efficiencies. Fully resolved (DNS) simulations will be used to test and possibly improve the mass-transfer correlations used for the unresolved model (DEM). DEM will be used to simulate the mass transfer on the length scale of the riser. These simulations will be experimentally validated by using ozone decomposition as model reaction at ambient conditions.

PROGRESS

An in-depth literature research has been performed to select a suitable model reaction to experimentally measure the mass transfer coefficient in riser reactors. Ozone decomposition, catalyzed by CuO/MnO over Al₂O₃ has been selected as the model reaction to compare computational with experimental results. Design of a pseudo-2D riser reactor has been completed. DEM code was adapted to incorporate mass diffusion-convection equations. Single-phase analytical cases have been validated (error function, Graetz-Nusselt case) and particle simulations are in progress.

DISSERTATIONS

-

SCIENTIFIC PUBLICATIONS

-

PROJECT AIM

- Determining and quantifying the relevant processes for contact mechanics of wet particles
- Deriving constitutive equations for contact interactions of wet particles that can be used in DEM simulations
- Testing the applicability of the derived constitutive equations through DEM simulations, by applying them for the cases of wet particles in fluidized beds and spout fluidized beds.

PROGRESS

The project was starting at March 2013 with employment of Mahraz as PhD student. The focus of work in this year was on Simulation and computational modeling of collision between a particle and a wet surface. In this simulation, the immersed boundary method (IBM) and volume of fluid (VOF) was combined together. The sensitivity of model to different parameters was examined, and The model was improved in different aspects.

DISSERTATIONS

-

SCIENTIFIC PUBLICATIONS

-

PROJECTLEADERS

JAM Kuipers, NG Deen

RESEARCHTHEME

Mathematical and computational methods for fluid flow analysis

PARTICIPANTS

M Behbood

COOPERATIONS

Institute of Solids Process
Engineering and Particle Technology
Hamburg University of Technology
(TUHH)

FUNDED

STW, Deutsche
Forschungsgemeinschaft (DFG)
University -
FOM -
STW 100 %
NWO Other -
Industry -
TNO -
GTI -
EU -
Scholarships -

START OF THE PROJECT

2013

INFORMATION

M Behbood
040 247 8053
m.behbood@tue.nl
[https://venus.tue.nl/ep-cgi/ep_detail.
opl?taal=US&fac_id=96&voor_org_
id=&rn=20137093](https://venus.tue.nl/ep-cgi/ep_detail.opl?taal=US&fac_id=96&voor_org_id=&rn=20137093)

DIRECT NUMERICAL SIMULATION OF NON-ISOTHERMAL FLOWS THROUGH STATIONARY ARRAYS OF BIDISPERSE SPHERES

PROJECT LEADERS

JAM Kuipers

RESEARCH THEME

Mathematical and computational methods for fluid flow analysis

PARTICIPANTS

H Tavassoli, EAJF Peters

COOPERATIONS

-

FUNDED

European Research Council

University -

FOM -

STW -

NWO Other -

Industry -

TNO -

GTI -

EU 100 %

Scholarships -

START OF THE PROJECT

2010

INFORMATION

JAM Kuipers

040 247 4158

J.A.M.Kuipers@tue.nl

www.chem.tue.nl/smr

PROJECT AIM

The purpose of this study is to examine the average heat transfer coefficient in stationary arrays of bidisperse spheres with using DNS. With the help of DNS of non-isothermal flow through the system, the heat transfer coefficients are obtained numerically in terms of Reynolds number, solids volume fraction and diameter ratio of the particles.

PROGRESS

In this study, we employ the Immersed Boundary method to simulate non-isothermal flows through a fixed bed packed with random bidisperse spherical particles. The physical model is constructed by distribution of 54 non-overlapping spherical particles in a cubic domain using a standard Monte Carlo procedure for hard spheres (Fig. 1). A cold fluid flows through the hot particles in the bed and interchanges the heat and momentum with particles. From the detailed flow and thermal fields, information on the average and distribution of the heat transfer coefficient of the system can be obtained. In Fig. 2 an example of the computed temperature distribution of the fluid inside a random array of bidisperse particles ($Re=50$, solid volume fraction = 0.5 and diameter ratio = 0.9) is shown.

DISSERTATIONS

-

SCIENTIFIC PUBLICATIONS

1. H. Tavassoli, S.H.L. Kriebitzsch, M.A. van der Hoef, E.A.J.F. Peters, J.A.M. Kuipers, Direct numerical simulation of particulate flow with heat transfer - International Journal of Multiphase Flow, Volume 57, December 2013, Pages 29-37.

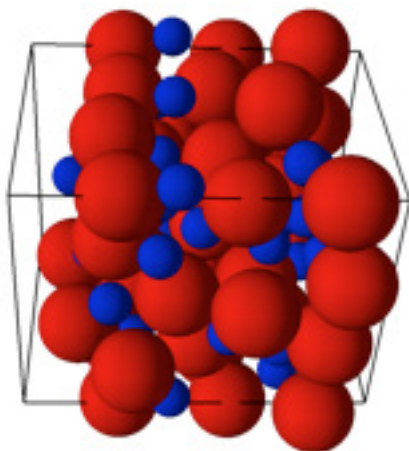

Example of a bidisperse system as studied in the DNS simulations. Diameter ratio and solid volume fraction are 2 and 0.5, respectively

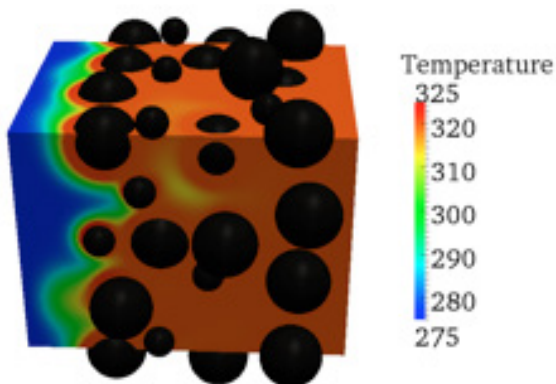

Computed fluid temperature (K) distributions in a random array of bidisperse particles. (Reynolds number = 50)

BUBBLES ON THE CUTTING EDGE: EXPERIMENTAL INVESTIGATION ON MICRO-STRUCTURED BUBBLE COLUMNS

PROJECT AIM

The aim of the project is to construct a laboratory scale micro-structured bubble column reactor with a wire mesh to demonstrate proof of principle. The impact of wire mesh on bubble cutting, hydrodynamics characteristics will be studied in-depth experimentally using advanced measurement techniques such as Laser Doppler Anemometry and X-ray tomography. X-ray tomography experiments will be done in co-operation with HZDR, Dresden, Germany. The reaction enhanced mass transfer will also be studied for the case of CO₂ in NaOH to determine interfacial area and mass transfer coefficient.

PROGRESS

Bubble column reactor design with a wire mesh insert has been constructed. Bubble cutting with different wire mesh opening and wire diameter was studied, using an advanced Digital Image Analysis technique(DIA). The average bubble size along height of the column and bubble size distribution before and after the wire mesh was determined using DIA. Bubble velocity field in the reactor was determined using Particle Image Velocimetry technique. A square bubble column reactor is under construction and experiments will be done using X-ray tomography. Experiments with chemical reaction will be done to study the effect of wire mesh on chemical reaction.

DISSERTATIONS

-

SCIENTIFIC PUBLICATIONS

1. Lau, Y. M., K. Thiruvalluvan Sujatha, M. Gaeini, N. G. Deen, and J. A. M. Kuipers. "Experimental study of the bubble size distribution in a pseudo-2D bubble column." *Chemical Engineering Science* (2013).

PROJECT LEADERS

NG Deen, JAM Kuipers

RESEARCH THEME

Mathematical and computational methods for fluid flow analysis

PARTICIPANTS

K Thiruvalluvan Sujatha

COOPERATIONS

HZDR, Dresden, Germany

FUNDED

| | |
|---------------------------|-------|
| European Research Council | |
| University | - |
| FOM | - |
| STW | - |
| NWO Other | - |
| Industry | - |
| TNO | - |
| GTI | - |
| EU | 100 % |
| Scholarships | - |

START OF THE PROJECT

2012

INFORMATION

NG Deen
040 247 3681
040 247 4931
N.G.Deen@TUE.nl
www.tue.nl/staff/N.G.Deen

PROJECT LEADERS

JAM Kuipers, M van Sint Annaland,
N Deen

RESEARCH THEME

Mathematical and computational
methods for fluid flow analysis

PARTICIPANTS

M Banaei, Z Li

COOPERATIONS

-

FUNDED

Dutch Polymer Institute (DPI)

University -

FOM -

STW -

NWO Other -

Industry 100 %

TNO -

GTI -

EU -

Scholarships -

START OF THE PROJECT

2012

INFORMATION

M Banaei

040 247 8026

m.banaei@tue.nl

PROJECT AIM

1. Extension of numerical models for prediction of hydrodynamics and heat transfer in polymerization reactors.

2. Developing the PIV/DIA measurements for pressurized gas fluidized beds and quantitative investigation of the heat effects of liquid injection.

PROGRESS

1. Literature survey.

2. Extending the existent two-fluid model code for consideration of energy balance: This part contains several parts and up to now some of the parts has been finished and verified.

3. Modification, safety checking and experimenting of some test cases of the pressurized setup for endoscopic PIV and ECT measurements:

This part also contains several sub-sections and it is still in the progress.

DISSERTATIONS

-

SCIENTIFIC PUBLICATIONS

-

POLYDISPERSED GRANULAR FLOWS THROUGH INCLINED CHANNELS

PROJECT AIM

The aims of the project are :

- To study the flow behavior of polydisperse granular particles on non-rotating and rotating chute.
- Prediction of influences of polydispersity and non-uniformity of the particles, on flow characteristics
- To compare the discrete particle model (DPM) simulation results with experimental measurement.

PROGRESS

Different sets of experiments were performed on monodisperse, binary size and binary density granular mixtures in a rotating chute to investigate the flow behaviour. The experiments have been performed for different angles of inclination, flow rates and rotation rates of the chute. The bed height and surface particle velocity in the chute was measured using electronic ultrasonic height sensors and Particle image velocimetry (PIV). A Particle Tracking Velocimetry (PTV) was used for tracking individual tracer particles in the flow to get more detailed surface flow information. A discrete element model of monodisperse flows has been validated for rectangular and semi-cylindrical chute by comparing with experimental results.

DISSERTATIONS

-

SCIENTIFIC PUBLICATIONS

1. Shirsath, S.S., Padding, J.T., Deen, N.G., Clercx, H.J.H. & Kuipers, J.A.M. (2013). Experimental study of monodisperse granular flow through an inclined rotating chute. Powder Technology, 246, 235-246.

PROJECT LEADERS

JAM Kuipers, JT Padding,
HJH Clercx

RESEARCH THEME

Mathematical and computational
methods for fluid flow analysis

PARTICIPANTS

SS Shirsath

COOPERATIONS

-

FUNDED

| | |
|--------------------|-------|
| STW and Tata Steel | |
| University | - |
| FOM | - |
| STW | 100 % |
| NWO Other | - |
| Industry | - |
| TNO | - |
| GTI | - |
| EU | - |
| Scholarships | - |

START OF THE PROJECT

2010

INFORMATION

JAM Kuipers
040 247 4158
J.A.M.Kuipers@TUE.nl
www.chem.tue.nl/smr



Raw



DEM

Snapshots of monodisperse granular material flowing down an inclined chute (top view, flowing from left to right of the picture) at an inclination angle of 30 degrees for rotation rate 16rpm

AN EFFICIENT MULTI-PARTICLE COLLISION APPROACH TO LARGE SCALE DISSIPATIVE GRANULAR AND MULTIPHASE FLOW

PROJECT LEADERS

JAM Kuipers

RESEARCH THEME

Mathematical and computational methods for fluid flow analysis

PARTICIPANTS

LJH Seelen, JT Padding

COOPERATIONS

-

FUNDED

ERC

NWO

University -

FOM -

STW -

NWO Other -

Industry -

TNO -

GTI -

EU 100 %

Scholarships -

START OF THE PROJECT

2012

INFORMATION

JAM Kuipers

040 247 4158

J.A.M.Kuipers@tue.nl

www.chem.tue.nl/smr

PROJECT AIM

The goal of the project is to obtain a Discrete Particle Method suitable for simulations of large scale granular flows. This method can give more insight into the formation of large scale heterogeneities that form in granular flows. A multi-particle collision dynamics (MPCD) approach will be used to coarse-grain the detail binary collisions that are usually modeled with DPM. This method, together with a GPU based implementation, will allow for the simulation of millions of particles.

PROGRESS

A two 3D version of the original MPCD method has been created and tested. The method is constructed in such a way that the second moments of the velocity distribution relax towards equilibrium in an isotropic way. The equation of state has been derived for the 3D method and a method for changing the equation of state has been tested.

DISSERTATIONS

-

SCIENTIFIC PUBLICATIONS

-

NEW DRIVING FORCES FOR DRY FRACTIONATION

PROJECT AIM

The project aim is to combine separation methods to enhance the separation (of crude food materials) in terms of energy efficiency. Therefore, it is important that there is no water needed as dehydration of the product is energy intensive. The main focus of the project will lie on the use of tribo-electrification as the base for the separation method. Our partners at WUR will experimentally investigate the tribo-electric charging of pneumatically conveyed powder, while we will do that via a numerical route using CFD-DEM. The combined insights will be used to develop a separator.

PROGRESS

It is shown that electrostatic interaction between the particles will become important for the particles trajectory (and thus their charging behavior) when the particles get charged (by the amount experimentally determined). The same holds for the charge induced at the (conducting) walls which can be modeled by image charges. A cut-off distance is derived in order to keep this computational expensive force within limits. For this cut-off it is derived that the influence of particles beyond this distance will always have a smaller value than some threshold. Furthermore, a literature study on tribo-electrification is performed. This shows that not much is really understood of this phenomenon making it hard to implement a valid model. However, first attempts are made, showing promising results.

DISSERTATIONS

-

SCIENTIFIC PUBLICATIONS

1. Conference proceeding at the annual meeting of the Electrostatics Society of America. - Modeling of tribo-electrification of a pneumatically conveyed powder in a squared duct using DEM-CFD.

PROJECTLEADERS

JAM Kuipers

RESEARCHTHEME

Complex structures of fluids

PARTICIPANTS

MW Korevaar (TU/e), JT Padding (TU/e), J Wang (WUR), M Schutyser (WUR)

COOPERATIONS

-

FUNDED

| | |
|--------------|-------|
| STW | |
| University | - |
| FOM | - |
| STW | 100 % |
| NWO Other | - |
| Industry | - |
| TNO | - |
| GTI | - |
| EU | - |
| Scholarships | - |

START OF THE PROJECT

2011

INFORMATION

M Korevaar,
040 247 3674
m.w.korevaar@tue.nl

NUMERICAL AND EXPERIMENTAL STUDY OF CYLINDRICAL GAS-SOLID FLUIDIZED BEDS

PROJECT LEADERS

JAM Kuipers

RESEARCH THEME

Mathematical and computational methods for fluid flow analysis

PARTICIPANTS

Vikrant, NG Deen, JT Padding

COOPERATIONS

-

FUNDED

European Research Council

University -

FOM -

STW -

NWO Other -

Industry -

TNO -

GTI -

EU 100 %

Scholarships -

START OF THE PROJECT

2010

INFORMATION

JAM Kuipers

040 247 4158

J.A.M.Kuipers@TUE.nl

www.chem.tue.nl/smr

PROJECT AIM

Aim of this project is to develop a Two fluid model (TFM) for fluidized beds in the cylindrical coordinate with advance numerical and computational approach. This approach will enhance the system in terms of computational complexity and lead to fast and robust computer simulations of fluidized beds even for larger dimensions geometry. Experiments are performed in collaboration with HDZR, Dresden Germany, using X-ray Tomography technique to study flow dynamic in a cylindrical fluidized beds. This experimentation results will be used to validate results from developed TFM. Further extending model for heat transfer and placement of internals inside the gas-solid fluidized beds.

PROGRESS

Two-fluid model (TFM) using KTGF theory for fluidized bed in cylindrical coordinates is developed with advance numerical and computational approach. Model is validated with experiments performed on ultrafast X-ray tomography (XRT). Results shows the good agreement with bubble characteristics from XRT. Particles flow characteristics were compared from experimental data available in literature (Lavernan et al. 2012). The speed of the code is further enhanced considerably with parallel implementation of the solver. Effect of bed diameter and pressure effect on fluidization have been investigated numerically.

DISSERTATIONS

-

SCIENTIFIC PUBLICATIONS

1. Verma, V., Deen, N.G., Padding, J.T., Kuipers, J.A.M., (2013), "Two-fluid modeling of three-dimensional cylindrical gas-solid fluidized beds using the kinetics theory of granular flow", Chem. Eng. Sci., 102:227–245.

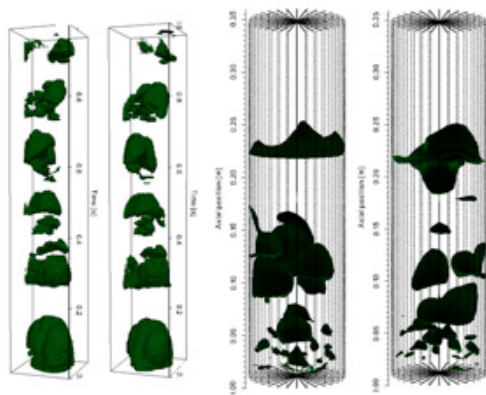

Bubble reconstructed from XRT measurement left and from TFM simulation right

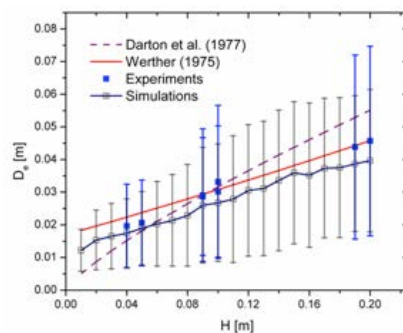

Equivalent bubble diameter as a function of height for LLDPE particles at inlet gas velocity of 2.0 Umf. Vertical bars represent standard deviations.

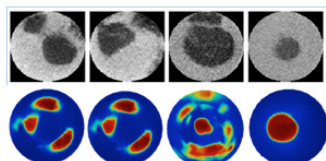

Bubble shape in the horizontal cross section plane: (top) X-ray imaging, (bottom) TFM simulations.

A COMBINED EXPERIMENTAL AND COMPUTATION STUDY OF THE MULTIPHASE FLOW IN THE SPRAY DRYER

PROJECT AIM

The main objective of this research is to develop a simulation tool that can provide the particle size, velocity and flux distribution for a highly turbulent gas flow section of a large-scale spray dryer. These results ought to be used as boundary conditions for coarse-grained simulations. For this purpose, we will use an Eulerian-lagrangian approach, while considering the various phenomena of collisions, coalescence and agglomeration between droplet-droplet, droplet-particle and particle-particle combinations in a highly turbulence gas flow at the top section (near the nozzle) of a spray dryer.

PROGRESS

We explore the development of an Euler-Lagrange model with a stochastic approach for the prediction of collision, coalescence and agglomeration of partially wet particles in a spray dryer. For the validation of that model, we simulated the same cases in a deterministic (Discrete Particle) simulation and compared the collision frequency with the one predicted by DSMC. The results are in good agreement. In a spray dryer, different kinds of events can occur when pair of particles collides. We implemented the elementary models for collision, coalescence, break-up, drying and agglomeration. For drying, we implemented the single droplet drying model using the reaction engg approach and validated with literature data. For the agglomeration study, we used the simple modelling approach using the Ohnesorge number.

DISSERTATIONS

-

SCIENTIFIC PUBLICATIONS

-

PROJECTLEADERS

JT Padding, NG Deen, JAM Kuipers

RESEARCHTHEME

Complex dynamics of fluids

PARTICIPANTS

SK Pawar

COOPERATIONS

-

FUNDED

Tetra Pak

University -

FOM -

STW -

NWO Other -

Industry 100 %

TNO -

GTI -

EU -

Scholarships -

START OF THE PROJECT

2010

INFORMATION

JAM Kuipers

040 247 4158

J.A.M.Kuipers@TUE.nl

www.chem.tue.nl/smr

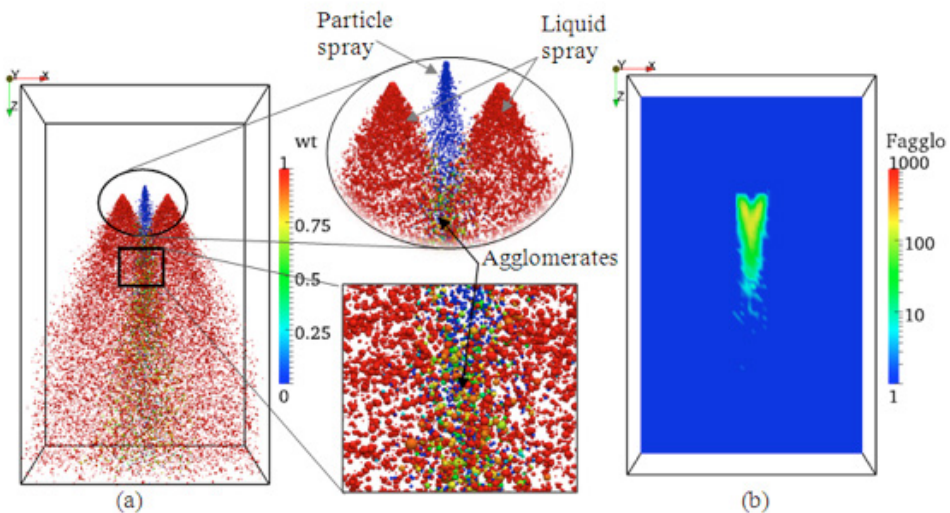

a) Two droplets sprays and one primary dry particle spray at the center. Droplets and particles collide and agglomerates are formed. Colors indicate wetness (wt) of the agglomerates (blue = completely dry, red = completely wet). b) Local frequency of agglomeration (Fagglo) events for the system shown in (a).

MULTI-SCALE MODELING OF MASS AND HEAT TRANSFER IN DENSE GAS-SOLID FLOWS: DIRECT NUMERICAL SIMULATIONS

PROJECT LEADERS

JAM Kuipers

RESEARCH THEME

Complex dynamics of fluids

PARTICIPANTS

MA van der Hoef, EAJF Peters,

Y Tang

COOPERATIONS

-

FUNDED

ERC

University -

FOM -

STW -

NWO Other -

Industry -

TNO -

GTI -

EU 100 %

Scholarships -

START OF THE PROJECT

2011

INFORMATION

JAM Kuipers

040 247 4158

J.A.M.Kuipers@TUE.nl

www.chem.tue.nl/smr

PROJECT AIM

This project is aimed at providing a comprehensive understanding of large-scale dense gas-solid flows based on first principles, which means the exchange of mass, momentum and heat at the surface of the individual solid particles.

PROGRESS

Immersed Boundary Method (IBM) is applied to perform direct numerical simulations of gas-solid flows in this project. The grid dependency of this method has been first studied, which gave us insight for developing a methodology to obtain highly accurate results of the gas-solid drag force. This methodology has been applied to compute the drag force in the gas flows past random arrays of spheres with a wide range of solids volume fraction $([0.1, 0.6])$ for Reynolds number up to 1000. A new drag correlation is obtained, which can better predict the drag in monodisperse gas-solid systems than the correlations existed in literature by far. Besides, we have investigated the effect of particles' mobility on the drag force, by performing the IBM simulations of freely moving particulate assemblies.

DISSERTATIONS

-

SCIENTIFIC PUBLICATIONS

-

HEAT TRANSFER IN DENSE PARTICULATE FLOW, AN EXPERIMENTAL STUDY TO PARTICLE FLUID CLOSURE RELATIONS

PROJECT AIM

The primary objective of this study is to develop new experimental techniques to study particle-fluid heat transfer. The second goal is to use these techniques to complement and validate the knowledge gained with the multi-scale modelling approach.

PROGRESS

Last year has been spend to develop a new particle tracking technique, called Magnetic Particle Tracking. The first findings have been written down and submitted to AIChE journal. In the coming year we hope to correct for influences of Earth's magnetic field and extend to cylindrical systems. These findings will also be compared to elements of the multi-scale modelling approach: Discrete Particle Model and Two Fluid Model. Secondly a technique is currently under development to be able to experiment on heat transfer characteristics of a single particle at varying particle fractions and Reynolds numbers. First results are expected in the beginning of 2014.

DISSERTATIONS

-

SCIENTIFIC PUBLICATIONS

-

PROJECTLEADERS

JAM Kuipers

RESEARCHTHEME

Complex dynamics of fluids

PARTICIPANTS

KA Buist, NG Deen, JAM Kuipers

COOPERATIONS

-

FUNDED

| | |
|--------------|-------|
| ERC | |
| University | - |
| FOM | - |
| STW | - |
| NWO Other | - |
| Industry | - |
| TNO | - |
| GTI | - |
| EU | 100 % |
| Scholarships | - |

START OF THE PROJECT

2012

INFORMATION

KA Buist
040 247 5740
K.A.Buist@tue.nl
www.tue.nl

EULER LAGRANGIAN MODELING OF DENSE PARTICLE-LADEN FLOW

PROJECT LEADERS

JAM Kuipers

RESEARCH THEME

Mathematical and computational methods for fluid flow analysis

PARTICIPANTS

AV Patil, EAJF Peters

COOPERATIONS

-

FUNDED

ERC

University -

FOM -

STW -

NWO Other -

Industry -

TNO -

GTI -

EU 100 %

Scholarships -

START OF THE PROJECT

2010

INFORMATION

A Patil

040 247 5582

A.V.Patil@tue.nl

PROJECT AIM

The aim of the project is to extend the multi-scale modeling of gas-fluidized beds with mass and heat transfer, where previously only momentum transfer between the gas and solid phase was considered.

PROGRESS

A heat transfer model for fluidized bed was implemented with heat transfer coupling between gas and particles in fluidized beds. The developed heat transport model is verified by comparisons with analytical equation before being put to use for fluidized bed study. In relation to verification, the model is verified by matching with a simple 1D coupled heat differential equation for two phase discretization and analytical equation obtained by its integration. Using the developed model bubble injection was performed in 2D bed with different injection temperature. This work contains a study of the formation and rise of hot gas bubbles in beds. This includes variations with changing particle sizes and injection temperatures. The mass flux of bubble is fixed to observe the changes in the formed bubble due to temperature. These simulation runs are also being extended for 3D systems having 3D bubbles. A part from this heat transfer between particles due to direct contact is being developed and implemented.

DISSERTATIONS

-

SCIENTIFIC PUBLICATIONS

-

PROJECT AIM

The main objective of this project is to fundamentally understand and quantitatively describe the complex mutual interactions between hydrodynamic characteristics of the fluidized bed and sorption in polymer particles, relevant for gas phase polymerization processes for polyolefins, especially when operated in condensed mode. A combined computational and experimental approach is followed. In-house developed CFD models are used to investigate the influence of sorption and swelling effects on the hydrodynamic behavior. A pseudo 2D fluidized bed is constructed to enable application of non-invasive optical measuring techniques like PIV and DIA to obtain information of the bubble and emulsion phases simultaneously under sorption conditions.

PROGRESS

The influence of temperature on the fluidization behavior of LLDPE particles has been investigated (under non-reactive conditions) and post-processed with an improved DIA algorithm, which measures the bubble behavior with a higher accuracy. Additionally, small-scale experiments on the swelling behavior of polymer particles under influence of ICA's (induced condensing agents) have been researched. Moreover, a pseudo-2D bed is constructed to experimentally investigate the effects of sorption on the hydrodynamic characteristics, i.e. solids circulation patterns and bubble size distributions. Furthermore, the importance of the collisional parameters (normal and tangential restitution and particle friction), temperature and swelling have been investigated in detail with a Discrete Particle Model.

DISSERTATIONS

-

SCIENTIFIC PUBLICATIONS

-

PROJECT LEADERS

M van Sint Annaland

RESEARCH THEME

Complex dynamics of fluids

PARTICIPANTS

HM Slagter, I Roghair

COOPERATIONS

-

FUNDED

Dutch Polymer Institute

University -

FOM -

STW -

NWO Other -

Industry -

TNO -

GTI -

EU 100 %

Scholarships -

START OF THE PROJECT

2010

INFORMATION

HM Slagter

h.m.slagter@tue.nl

040 247 8025

M van Sint Annaland

m.v.SintAnnaland@tue.nl

040 247 2241

www.tue.nl

PROJECT LEADERS

M van Sint Annaland, F Gallucci

RESEARCH THEME

Complex dynamics of fluids

PARTICIPANTS

I Campos Velarde

COOPERATIONS

-

FUNDED

ADEM

University -

FOM -

STW -

NWO Other -

Industry -

TNO -

GTI -

EU 100 %

Scholarships -

START OF THE PROJECT

2011

INFORMATION

I Campos Velarde

040 247 3685

06 521 21106

i.camposvelarde@tue.nl

www.tue.nl

PROJECT AIM

In the ECN MILENA Process, biomass is gasified by an indirect route comprising of a system of two coupled reactors. The performance of both interlinked reactors (bubbling fluidized bed reactor and riser reactor) is investigated in detail in relation to their respective operating conditions, especially focusing on the heat and oxygen transport in the system, and the effect of the residence time of gas and particles. Advanced experimental techniques (PIV/DIA) are applied to study the hydrodynamics and to quantify the rate of heat and oxygen transport. An extended phenomenological model is developed and used for process optimization and scale-up effects.

PROGRESS

The novel technique (ePIV/DIA) has been developed to study the hydrodynamics of gas-solid fluidized beds at high temperatures. The use of a new camera Dantec FlowMaster 16M coupled to a high temperature optical endoscope and the new laser EverGreen 70mJ have been validated at room temperature in a cold flow set up, and tests at high temperatures (up to 1000 °C) are ongoing. Moreover, a model for the indirect gasification of biomass has been developed with Aspen Plus. The first step of the model considers sand as bed material. The products of the biomass devolatilization were estimated using empirical correlations from the open literature. Reaction kinetics for the homogeneous reactions are implemented. In the next step, the use of an oxygen carrier will be implemented.

DISSERTATIONS

-

SCIENTIFIC PUBLICATIONS

1. Development of a High Temperature Endoscopic-Laser PIV/DIA Technique for the Study of Hydrodynamics of Gas-Solids Proceedings Fluidized Beds. Fluidization XIV 2013.

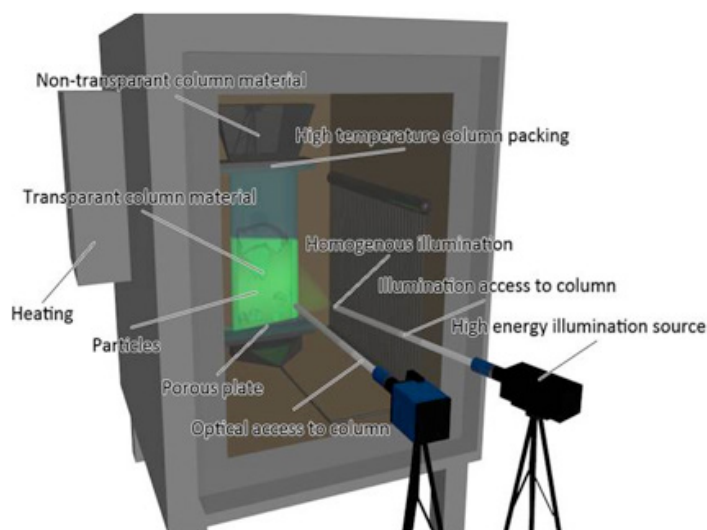

Schematic of the high-temperature endoscopic PIV setup

HYDRODYNAMICS, MASS TRANSFER STUDY AND DEMONSTRATION OF CHEMICAL LOOPING REFORMING FOR PURE HYDROGEN PRODUCTION WITH INTEGRATED CO₂ CAPTURE

PROJECT AIM

A novel chemical looping membrane reactor for hydrogen production from steam methane reforming with integrated CO₂ capture is studied using Pd-membranes for hydrogen separation. The effects of the membranes and external solids circulation on the hydrodynamics of the fuel and air reactors are studied in detail. The reactor concept will also be experimentally demonstrated and a detailed reactor model is being developed to describe its performance. Finally, a techno-economic analysis will be carried out to demonstrate the applicability at large scale.

PROGRESS

A thermodynamic analysis of the reactor concept was carried out and compared with other reactor concepts in order to demonstrate the potential of the proposed reactor. It was shown that the mentioned concept can represent an important improvement in comparison to conventional and competing technologies. In addition, oxygen carriers for Chemical Looping Reforming have been investigated. A hydrodynamic study has been carried out for horizontally immersed membranes in a pseudo-2D bed using PIV/DIA. Another 2D setup is under construction to study in detail the effects of the external solids circulation on the hydrodynamics in interconnected fluidized bed reactors. A new phenomenological model for fluidized bed membrane reactors is also being developed.

DISSERTATIONS

-

SCIENTIFIC PUBLICATIONS

1. Medrano JA, et al., Thermodynamic analysis of a membrane-assisted chemical looping reforming reactor concept for combined H₂ production and CO₂ capture, International Journal of Hydrogen Energy (2013), <http://dx.doi.org/10.1016/j.ijhydene.2013.11.126>.

Sketch of the chemical-looping reforming process using an air reactor to oxidize the carrier particles and a fuel reactor where the oxygen is consumed and hydrogen is produced and separated via immersed membranes.

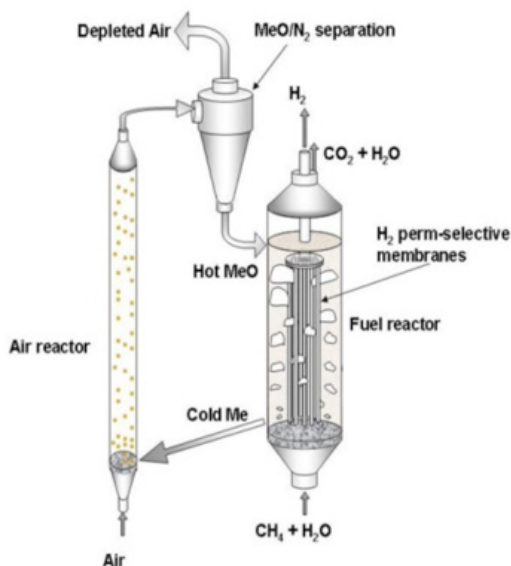

PROJECT LEADERS

F Gallucci, M van Sint Annaland, I Roghair

RESEARCH THEME

Complex dynamics of fluids

PARTICIPANTS

J.A. (José Antonio) Medrano Jiménez, R (Ramon) Voncken and Dr. V (Vincenzo) Spallina

COOPERATIONS

Hygear, SINTEF, Tecnalia, Shell, ECN

FUNDED

| | |
|--------------|--------|
| STW | |
| University | 12,1 % |
| FOM | - |
| STW | 87,9 % |
| NWO Other | - |
| Industry | - |
| TNO | - |
| GTI | - |
| EU | - |
| Scholarships | - |

START OF THE PROJECT

2013

INFORMATION

JA Medrano Jiménez
040 247 8055
06 420 55 727
j.a.medrano.jimenez@tue.nl
www.tue.nl

FUNDAMENTALS OF THE CHEMICAL LOOPING REFORMING FOR PURE HYDROGEN PRODUCTION WITH INTEGRATED CO₂ CAPTURE (CLINGCO₂)

PROJECT LEADERS

F Gallucci, M van Sint Annaland,
I Roghair

RESEARCH THEME

Mathematical and computational
methods for fluid flow analysis

PARTICIPANTS

V Spallina, JA Medrano Jimenez,
RJW Voncken

COOPERATIONS

Hygear, SINTEF, Tecnalia, Shell,
ECN

FUNDED

| | |
|--------------|--------|
| STW, TU/e | |
| University | 12,9 % |
| FOM | - |
| STW | 87,1 % |
| NWO Other | - |
| Industry | - |
| TNO | - |
| GTI | - |
| EU | - |
| Scholarships | - |

START OF THE PROJECT

2013

INFORMATION

RJW Voncken
040 247 8180
r.j.w.voncken@tue.nl
www.tue.nl

PROJECT AIM

- Gaining knowledge on hydrodynamics, transport phenomena and kinetics in a fluidized bed reactor with hydrogen permeable membranes and heterogeneously catalyzed chemical reactions
- Scale-up of the Membrane Assisted-Chemical Looping Reforming (MA-CLR) concept
- Describing the effect of solids circulation on the MA-CLR reactor system
- Determining and improving the accuracy of the simulated data by performing experiments
- Performing a detailed investigation on various important reactor parameters and phenomena.

PROGRESS

Discrete Element Method (DEM) codes, and a continuum model code are being developed to model fluidized bed membrane reactors. For the continuum model simulations, OpenFOAM is used to simulate various experimental fluidized bed membrane reactor set-ups. An in-house code, OpenFOAM and the open source DEM software LIGGGHTS / CFDEM are used for DEM simulations. For both the continuum model and the DEM models, the extraction and addition of gas via either immersed membranes or membranes in the fluidized bed walls are being investigated. This way, phenomena such as the occurrence of gas-pockets around and concentration polarization at the membranes can be understood and quantified. Extension and improvement of these hydrodynamics based models to mass and heat transfer, and chemical reactions are on-going topics during a large part of this project.

DISSERTATIONS

-

SCIENTIFIC PUBLICATIONS

-

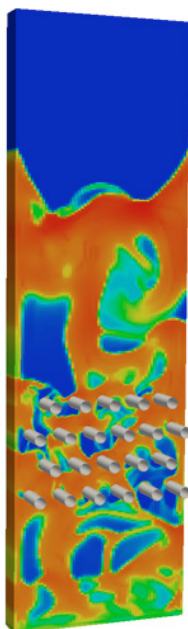

Typical simulation result of a two-fluid model with immersed membranes

UNRAVELLING THE ORIGIN OF THE REDOX KINETICS BEHAVIOR OF OXYGEN CARRIERS IN CHEMICAL LOOPING COMBUSTION

PROJECT AIM

The project aims : a) detailed characterization of oxygen carriers to develop novel particle models that better describe the redox kinetics accounting for morphological and structural changes prevailing during consecutive reduction and oxidation cycles; b) Extension of the particle models with thermodynamics and their verification and validation; c) Experimental investigations in a packed bed CLC setup (testing different oxygen carriers); d) Embedding of the new particle models in the available reactor model for packed bed CLC, e) Detailed simulations of the CLC process with the new models.

PROGRESS

Experimental studies of different oxygen carriers have been carried out to obtain more detailed knowledge about the kinetics using Thermo Gravimetric Analysis (TGA), the morphological changes with BET (surface area, porosity, pore size distribution), and the structural and phase changes of the particles with SEM-EDX and XRD. A new multi-scale particle model is being developed with homogenization techniques taking into account morphological and structural changes of the particles during the reactions.

DISSERTATIONS

-

SCIENTIFIC PUBLICATIONS

-

Conventional particle models cannot well describe the measured particle conversion rates in chemical looping combustion

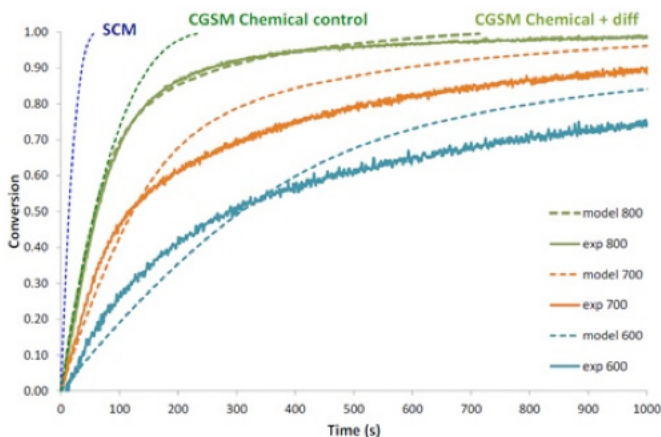

PROJECT LEADERS

M van Sint Annaland, I Roghair,
F Gallucci

RESEARCH THEME

Mathematical and computational
methods for fluid flow analysis

PARTICIPANTS

Maria Angel San Pio Bordeje (PhD-
Student), Martin van Sint Annaland
(Prof.dr.ir., thesis supervisor), Ivo
Roghair (Dr.ir., daily guidance)

COOPERATIONS

PhD students of Norway research
council, VID1 project (Gallucci),
group of SINTEF in Norway, VITO
in Belgium, ECN and TNO in the
Netherlands. Collaboration with
prof.G.Lozza from Politecnico di
Milano.

FUNDED

Echo Project Grant, NWO
(Netherlands Organization for
Scientific Research)

| | |
|--------------|-------|
| University | - |
| FOM | - |
| STW | - |
| NWO Other | 100 % |
| Industry | - |
| TNO | - |
| GTI | - |
| EU | - |
| Scholarships | - |

START OF THE PROJECT

2013

INFORMATION

M van Sint Annaland
040 247 2241
m.v.sintannaland@tue.nl
www.tue.nl



Prof.dr. WJ Briels

The Computational BioPhysics group (CBP) at the University of Twente is interested in the rheological and thermodynamical properties of complex soft matter. Typical multiphase systems being studied include dispersions of hard particles, e.g. spherical colloids or rod-like fd viruses, dispersed in Newtonian and non-Newtonian liquids. Close to equilibrium, the rheological properties are determined by the structural properties of the dispersed phase. Since these structures are usually stabilized by free energies in the order of several kT , they can easily be perturbed by applying flow gradients, which thus give rise to flow-induced modifications of the rheological properties. Well known phenomena resulting from this interplay between structure and flow are shear thinning, shear banding and temporal oscillations of optical and rheological properties in liquid crystalline polymer solutions. Self-assembly plays an important role in a number of systems being studied, ranging from surfactant-based worm-like micelles and lipid bilayers to various proteins that form neatly ordered structures, e.g. fibers and cages, or merely aggregate into disordered protein plaques. We are also interested in the rheology of linear and branched polymers, and the role played herein by entanglements.

The tools that we use belong to the field of particle based computer simulations. Since a full description of the observed phenomena requires a multi-scale approach, our simulation methods range from Molecular Dynamics (MD) and Monte Carlo (MC) to Multi Particle Collision Dynamics (MPCD) and Brownian Dynamics (BD). Detailed atomistic simulations are used to calculate the free energies that constitute the main interactions in subsequent simulations at a mesoscopic level. Our main strength is in developing new methods for (highly) coarse-grained simulations. We have, for instance, developed the twentanglement algorithm to investigate entangled melts of linear and branched polymers, introduced event-driven BD algorithms to simulate colloidal suspensions, developed Responsive Particle Dynamics (RaPiD) to study the flow properties of several non-linear fluids, and extended the patchy-particle approach to non-spherical particles to simulate self-assembly of protein clusters.

A SINGLE-MOLECULE VIEW ON PROTEIN AGGREGATION (SMPA)

PROJECT AIM

The goal of the SMPA consortium, a collaboration of 8 Dutch research groups, is to unravel the physical mechanisms that underlie protein aggregation in the brains of patients suffering Parkinson's disease. To gain insight into the nucleation and growth process, the Computational BioPhysics group will develop a novel highly coarse-grained modeling technique specifically aimed at the secondary and tertiary structure of proteins. This method will be used to simulate and explore the formation and structure of alpha-synuclein aggregates.

PROGRESS

We have developed a novel technique to efficiently simulate the translational and rotational Brownian dynamics of rigid anisotropic bodies. The algorithm was validated by an extensive series of tests. Using a recently in-house developed patchy-particle model of the three-legged clathrin protein, we have shown the ability of this algorithm to simulate the self-assembly of complex particles into highly ordered structures on a realistic time scale, see picture. A representation of the alpha-synuclein protein as a short chain of patchy particles, representing about 15 amino acids each, is under development.

DISSERTATIONS

-

SCIENTIFIC PUBLICATIONS

-

PROJECT LEADERS

WJ Briels, WK den Otter

RESEARCH THEME

Complex structures of fluids

PARTICIPANTS

IM Ilie

COOPERATIONS

-

FUNDED

FOM

University -

FOM 100 %

STW -

NWO Other -

Industry -

TNO -

GTI -

EU -

Scholarships -

START OF THE PROJECT

2011

INFORMATION

WJ Briels

053 489 2947

w.j.briels@utwente.nl

<http://cbp.tnw.utwente.nl>

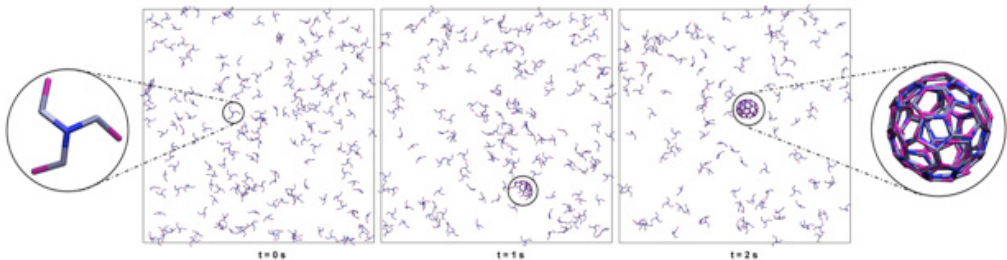

MESOSCALE MODELING OF SHEAR-THINNING POLYMER SOLUTIONS

PROJECT LEADERS

WJ Briels

RESEARCH THEME

Complex dynamics of fluids

PARTICIPANTS

IS Santos de Oliveira, BW Fitzgerald, WK den Otter

COOPERATIONS

-

FUNDED

ESMI – European Soft Matter Infrastructure.

University -

FOM -

STW -

NWO Other -

Industry -

TNO -

GTI -

EU 100%

Scholarships -

START OF THE PROJECT

2012

INFORMATION

WJ Briels

053 489 2947

w.j.briels@utwente.nl

http://cbp.tnw.utwente.nl

PROJECT AIM

The aim of the project is to simulate the linear and non-linear rheology of viscoelastic polymer solutions. In the highly-coarse grained algorithm known as Responsive Particle Dynamics (RaPiD), polymers are modelled as point particles with entanglement interactions between the polymers accounted for by transient forces. A previous study revealed that the RaPiD model with spherical particles does not entirely capture the non-linear rheology of viscoelastic fluids. A deformable particle representation will be developed, providing the particles with more time and neighbours to entangle with, in order to achieve a better description of shear-thinning in these fluids.

PROGRESS

The RaPiD model has been revised by the introduction of a deformable particle capable of elongation, with a FENE potential providing a free energy penalty to elongation. After tuning the model, the linear rheology of two polymer solutions was recovered to excellent agreement. Crucially, the shear-thinning behaviour of both fluids is now also successfully being reproduced, as shown in the figure. This confirms the importance of particle elongation towards describing the non-linear rheology. Particle deformation and alignment are shown to increase with shear rate, where the former is associated with entanglements between particles prevailing for longer periods.

DISSERTATIONS

-

SCIENTIFIC PUBLICATIONS

1. Alignment and segregation of bidisperse colloids in a shear-thinning viscoelastic fluid under shear flow. I.S. Santos de Oliveira, W.K. den Otter and W.J. Briels EuroPhys. Lett. 101, 28002 (2013).

Demonstration of Shear Thinning Behaviour for PIB polymer solution

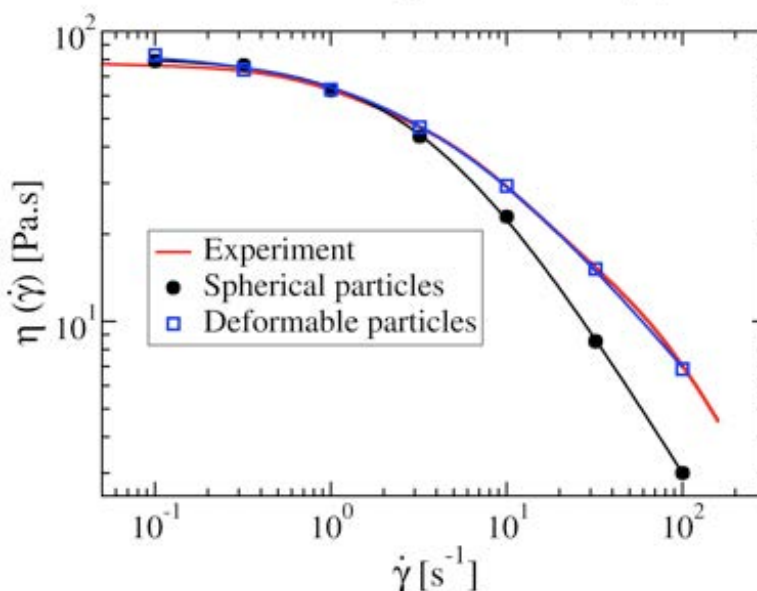

MODELING OF THE LINEAR AND NONLINEAR RHEOLOGY OF STAR POLYMER MELTS

PROJECT AIM

The aim of the project is to compare experiments and simulations on the linear and nonlinear rheology of moderate functionality, low molecular weight polystyrene (PS) star polymer melts. The stars will be simulated using highly coarse-grained Responsive Particle Dynamics, mapping a star onto a single particle. Transient interactions between the particles are introduced to represent the entanglements of the stars. After tuning the model to reproduce the linear rheology of the melt, we will study the response of the melt to a series of experimental shear protocols in order to advance the interpretation of these experiments.

PROGRESS

A series of experiments on the linear rheology and the response of the melts to shear protocols have been carried out by our collaborators at their facility (FORTH, Crete). The RaPiD algorithm has been customized for the simulation of star polymers by the selection of an appropriate free energy potential and a description of inter-star entanglements. Firstly the linear rheology has been recovered to good agreement with experiments, see figure. Next, a start-up shear protocol was simulated for a number of shear rates and compared to experimental data. Qualitative features such as stress overshoot and steady-state response are recovered, although there are deviations from experiment at the highest shear rates. Shut-down protocols coincide with results from linear rheology where relaxations are independent of the initial stress state. Shear protocol simulations are on-going.

DISSERTATIONS

-

SCIENTIFIC PUBLICATIONS

-

PROJECT LEADERS

WJ Briels

RESEARCH THEME

Complex dynamics of fluids

PARTICIPANTS

BW Fitzgerald

COOPERATIONS

D. Vlassopoulos (FORTH, Crete)

H. Lentzakis (FORTH, Crete)

FUNDED

ESMI – European Soft Matter

Infrastructure

University -

FOM -

STW -

NWO Other -

Industry -

TNO -

GTI -

EU 100 %

Scholarships -

START OF THE PROJECT

2011

INFORMATION

WJ Briels,

053 489 2947

w.j.briels@utwente.nl

Linear Rheology of PS Star Polymer Melt from Experiments and Simulations

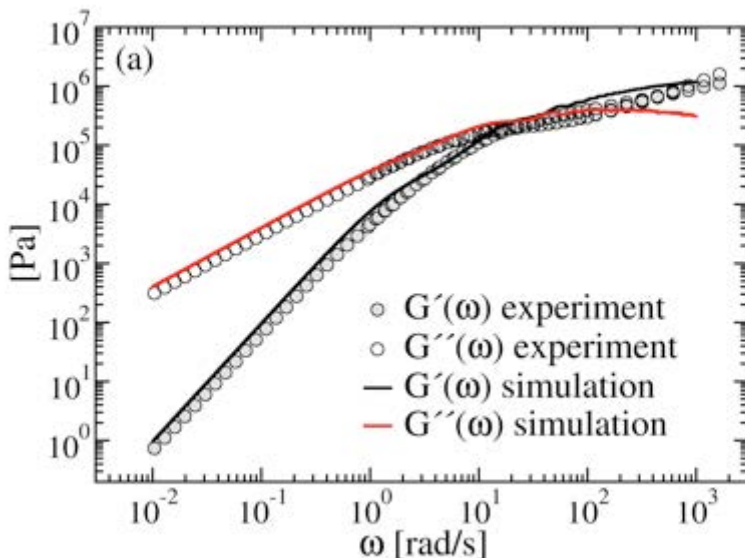

PROJECT LEADERS

WJ Briels

RESEARCH THEME

Complex dynamics of fluids

PARTICIPANTS

G Villalobos, WK den Otter

COOPERATIONS

-

FUNDED

ESMI – European Soft Matter

Infrastructure

University -

FOM -

STW -

NWO Other -

Industry -

TNO -

GTI -

EU 100 %

Scholarships -

START OF THE PROJECT

2011

INFORMATION

WJ Briels

053 489 2947

w.j.briels@utwente.nl

http://cbp.tnw.utwente.nl

PROJECT AIM

Organic photovoltaic cells have the advantage over conventional solid state solar cells that they can potentially be mass-produced by standard roll-to-roll printing techniques, thereby drastically reducing the production costs. Understanding the rheological behavior of the printing solution containing the active ingredients is crucial to the reliable production of efficient solar cells. The aggregation of the lath-shaped P3HT molecules into fibrils upon cooling down from printing temperature to ambient temperature gives rise to complex rheological behavior.

PROGRESS

We have developed a simulation model to study the aggregation process of long slender lath-shaped molecules which interact most strongly in the direction perpendicular to their largest facets (by several aromatic interactions). This was achieved by modeling the molecules as single particles; the interaction between two laths depends on their distance and relative orientations. We find that these laths self-assemble into long ordered aggregates upon lowering the temperature, with the stress auto-correlation function of the fluid changing simultaneously to acquire gel-like characteristics. These results are in agreement with experimental data.

DISSERTATIONS

-

SCIENTIFIC PUBLICATIONS

-

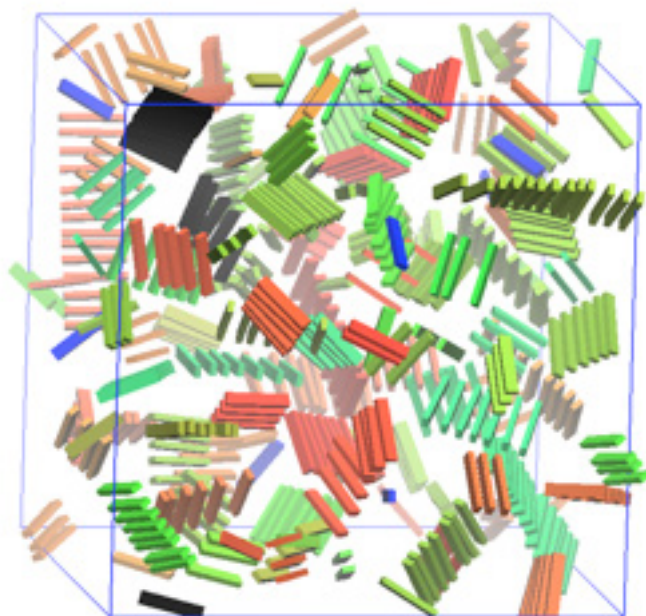

Early stage of laths aggregating to form fibrils.

PROJECT AIM

Topologically complex polymers, such as stars, combs and H-shaped polymers, exhibit complex dynamic and rheological properties, including hierarchical relaxation processes with many different time scales. The aim of this project is to study the flow behavior of branched polymers, which is a major issue in the industrial application of these polymers, by coarse-grained simulations.

PROGRESS

The coarse-grained TWENTANGLEMENT algorithm, originally developed for the simulation of melts of linear polymers, has been adapted to simulate branched polymers. In this algorithm, bond crossings between chains of soft beads – a direct result of coarse graining – are being detected and prevented by introducing entanglement points. We have implemented the dynamics of an entanglement point near a branching point. The method was tested by ‘branching’ two linear chains into a single linear chain, recovering the correct dynamics of the longer chain. Next, melts of three-armed stars were simulated. We find that the diffusive behavior of these stars is close to that of a linear polymer with the same molecular weight, see figure, while the rheology of the melt resembles that of linear chains with the same longest backbone length, see figure.

DISSERTATIONS

-

SCIENTIFIC PUBLICATIONS

- Coarse-grained simulation of moderately entangled star polyethylene melts
L.Liu, J.T.Padding, W.K.den Otter and W.J.Briels. J. Chem. Phys. 138, 244912 (2013).

PROJECT LEADERS

WJ Briels

RESEARCH THEME

Complex dynamics of fluids

PARTICIPANTS

L Liu, WK den Otter

COOPERATIONS

JT Padding (TUE)

FUNDED

| | |
|---|-------|
| DYNAMics of Architecturally Complex Polymers (DYNACOP) University | - |
| FOM | - |
| STW | - |
| NWO Other | - |
| Industry | - |
| TNO | - |
| GTI | - |
| EU | 100 % |
| Scholarships | - |

START OF THE PROJECT

2009

INFORMATION

WJ Briels,
053 489 2947
w.j.briels@utwente.nl

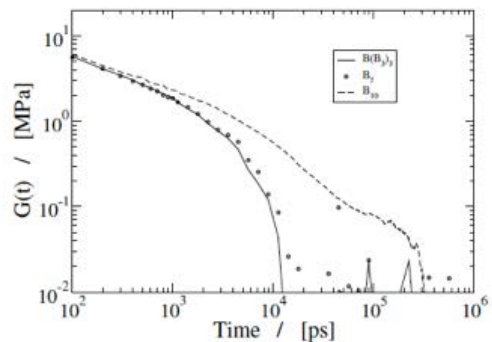
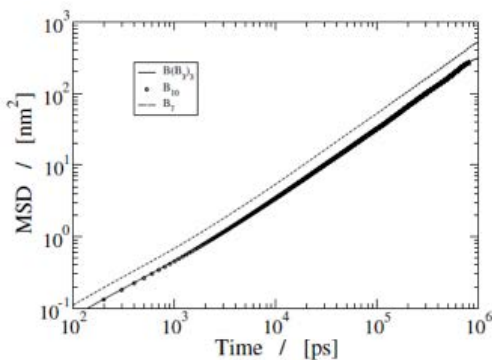

Mean square displacements (left) and stress autocorrelation functions (right).



Prof.dr. D Lohse



Prof.dr. A Prosperetti



Prof.dr.ir. L van Wijngaarden



Prof.dr. JF Dijkstra



Prof.dr.ir. D van der Meer



Prof.dr. R Verzicco

The Physics of Fluids group in Twente works on a variety of aspects in fluid mechanics, in particular on those related to bubbles. The focus of our work is the fundamental understanding of the phenomena of the physics of fluids, bubbles and jets, which we undertake by experimental, numerical and theoretical means. Besides in the J.M.Burgers Center, our research is embedded in the Research Institute of Mechanics, Processes and Control IMPACT, the MESA+ Institute, and the Research Institute for Biomedical Technology BMTi of the University of Twente. The group receives external research funds mainly from FOM, but also from STW, NWO, SenterNovem, EU and several companies. The focus research areas of the group are:

TURBULENCE AND TWO-PHASE FLOW

Fully developed turbulence is one of the big unsolved problems in fluid dynamics. The main question is the distribution of rare events, which has important implications for, e.g., flight safety. We approach this problem from a fundamental point of view, both experimentally, theoretically, and numerically. One particular important type of turbulence is turbulence (partly) driven by body forces, such as buoyancy. This can happen by either thermally driving the turbulence or also by driving the turbulence through bubbles or dispersed particles. Both will be advected by the flow but also act back on the surrounding liquid (two-way coupling). To be able to describe flow with many bubbles or particles efficiently, one needs an effective force description, on which and with which we work in several projects within our group. Finally, we are also interested in the radial dynamics of single bubbles in hydrodynamic or acoustic fields.

GRANULAR FLOW

Granular flows are fundamentally different from any other type of flow. In our research we focus on the clustering phenomenon that finds its origin in the inelastic collisions between the particles. There is much emphasis on the onset of clustering, which happens via a phase transition which is studied in both compartmentalized and continuous systems. Another line of our research deals with the impact of objects on very fine, decompactified sand, in which we explore the applicability of fluid models to granular systems. We uncovered links to distant phenomena like asteroid impact and a dry variety of quicksand.

MICRO- AND NANOFUIDICS

The physics of fluids at the microscale can be quite different from macrofluidic behavior. Here we study disturbing bubbles in microchannels found in ink jet printing. By patterning surfaces on sub-micron scales we try to identify individual 'nanobubbles' which may lead to a quantitative understanding of wall slip. These patterned surfaces may also serve as nucleation sites for cavitation bubbles generated through intense negative pressures.

BIOMEDICAL FLOW

Bubbles have various applications in the biomedical field. Coated microbubbles are used in ultrasound imaging to enhance the contrast in cardiac or liver perfusion images. Bubbles can be targeted to specific cells for molecular imaging to non-invasively detect the presence and location of diseases such as cancer or atherosclerosis. Furthermore, the bubbles can be exploited to generate acoustic streaming and jetting near cell boundaries which leads to permeation, destruction or removal of target cells.

THE ROLE OF VAPOR/AIR LAYER IN DROPLET-SURFACE INTERACTIONS

PROJECT AIM

(1) To study the air entrainment and splashing processes of impacting droplet on various kinds of surfaces: smooth solid surfaces, micro-structured solid surfaces, solid surfaces covered by a thin liquid film, liquid surfaces,

(2) To study the boiling and hydrodynamic processes of liquid droplets on superheated surfaces, in particular, the role of the vapor layer in affecting the spreading and boiling behaviors of droplets.

PROGRESS

Highlights:

- Laser interferometry method to measure the thickness of vapor layer under impacting droplet.
- Study of dynamic Leidenfrost temperature for various roughnesses and materials.
- Splashing threshold and mechanism of impacting Leidenfrost droplet.
- Jetting and fragmentation of droplet in the contact boiling regime.

DISSERTATIONS

-

SCIENTIFIC PUBLICATIONS

1. Tuan Tran, Hendrik J. J. Staat, Arturo Susarrey-Arce, Tobias C. Foertsch, Arie van Houselt, Han J. G. E. Gardeniers, Andrea Prosperetti, Detlef Lohse, and Chao Sun, Droplet impact on superheated micro-structured surfaces, *Soft Matter*, 2013, 9, 3272-3282.

PROJECT LEADERS

D Lohse, C Sun

RESEARCH THEME

Complex dynamics of fluids

PARTICIPANTS

MAJ van Limbeek, D Lohse, A Prosperetti, M Shirota, HJJ Staat, C Sun

COOPERATIONS

-

FUNDED

| | |
|--------------|-------|
| University | - |
| FOM | 100 % |
| STW | - |
| NWO Other | - |
| Industry | - |
| TNO | - |
| GTI | - |
| EU | - |
| Scholarships | - |

START OF THE PROJECT

2011

INFORMATION

C Sun
053 489 5604
c.sun@utwente.nl
<http://pof.tnw.utwente.nl>

Representative series of snapshots during impact taken from the side and the bottom-views showing spreading and boiling processes of droplet impact on a smooth sapphire surface in (a) contact boiling regime, and (b) film boiling regime.

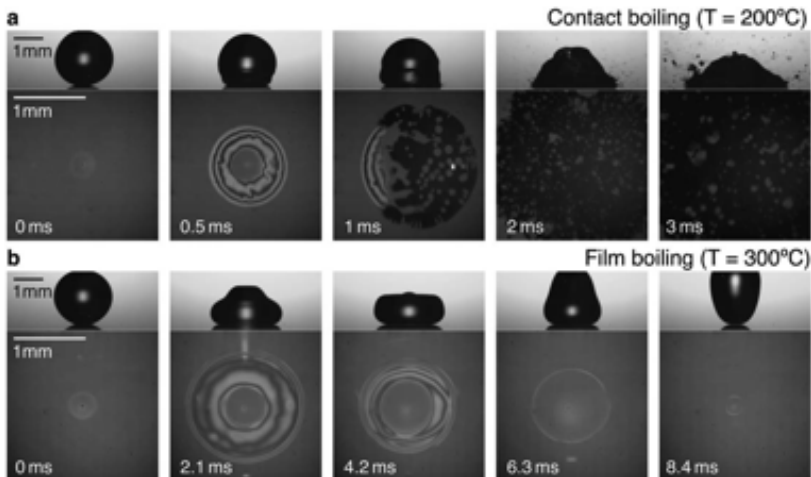

PROJECT LEADERS

D Lohse, C Sun

RESEARCH THEME

Complex dynamics of fluids

PARTICIPANTS

CW Visser, S Wildeman, M Gielen

COOPERATIONS

University of Göttingen

FUNDED

FOM

University -

FOM 100 %

STW -

NWO Other -

Industry -

TNO -

GTI -

EU -

Scholarships -

START OF THE PROJECT

2011

INFORMATION

Chao Sun

c.sun@utwente.nl

pof.tnw.utwente.nl

PROJECT AIM

- (1) To study and optimize the generation of extremely fast laser-induced microjets;
- (2) Study the impact of these jets and the impact of jet-generated droplets. In particular, the use for needle-free injection (i.e. shooting the jet through the skin to deliver medicine to humans) will be explored.

PROGRESS

Highlights:

- The impact of high-speed microdroplets was studied in detail by application of flash photography. This revealed details of the rim dynamics and spreading dynamics that could not be addressed before.
- The droplet impact was numerically modeled. The (previously mentioned) high-resolution measurements were successfully used to validate this model. The flow inside the droplet is currently being analyzed – we focus on boundary layer dynamics, rim dynamics, and the shear applied by the droplets. This is crucial for industrial applications.
- Within the project, Marise Gielen (MSc student), Hille Groendijk, and Boris Boom (BSc students) successfully graduated.

DISSERTATIONS

-

SCIENTIFIC PUBLICATIONS

1. Karatay, E., Haase, A.S., Visser, C.W., Sun, C., Lohse, D., Tsai, P.A., & Lammertink, R.G.H. (2013). Control of slippage with tunable bubble mattresses”, Proceedings of the National Academy of Sciences, 110 (21): 8422-8426.
2. Pohl, R. Visser, C.W., Römer, G.R.B.E., Sun, C., Huis in 't Veld, A.J. , & Lohse, D. (2013). Droplet ejection in laser-induced forward transfer: mechanism for droplet fragmentation” LAMP2013 - 6th International Congress on Laser Advanced Materials Processing, Jul 2013, Nigata, Japan.
3. Huis in 't Veld, A.J. , Hoppenbrouwers, M.B., Giesbers, M., Pohl, R., Romer, G.R.B.E., Visser, C.W., Sun, C., & Lohse, D., (2013). Imaging of copper ejection in pico- and nanosecond Laser Induced Forward Transfer” 4M Conference, Oct 2013, San Sebastian, Spain.



ENHANCED GROWTH OF INTERACTING BUBBLES

PROJECT AIM

The aim of the project is to improve the quantitative understanding of the physical mechanisms involved in gas exsolution and bubble formation under conditions mimicking those encountered in an oil field.

PROGRESS

Results for the growth of a single bubble in a supersaturated water-CO₂ solution and the onset of convection around it have been accepted for publication in the Journal of Fluid Mechanics at the end of the year. We have also explored the de-activation of nucleation sites in collaboration with Dr. Xuehua Zhang from the University of Melbourne. The study of interactive growth of two and three bubbles is currently underway. Parallel to this, we are exploring the dissolution of bubbles upon re-compression of the solution.

DISSERTATIONS

-

SCIENTIFIC PUBLICATIONS

1. O.R. Enríquez, C. Hummelink, G-W. Bruggert, D. Lohse, A. Prosperetti, D. van der Meer and C. Sun, Growing bubbles in a slightly supersaturated solution, Rev. Sci. Instrum., 84, 065111 (2013).
2. X. Zhang, H. Lhuissier, O.R. Enríquez, C. Sun and D. Lohse, Deactivation of Microbubble Nucleation Sites by Alcohol–Water Exchange, Langmuir, 29, 9979-9984, 2013.

PROJECT LEADERS

D Lohse, A Prosperetti, D van der Meer, C Sun

RESEARCH THEME

Complex dynamics of fluids

PARTICIPANTS

OR Enríquez

COOPERATIONS

Dr. Xuehua Zhang

FUNDED

| | |
|---------------|-------|
| Shell/FOM IPP | - |
| University | - |
| FOM | 100 % |
| STW | - |
| NWO Other | - |
| Industry | - |
| TNO | - |
| GTI | - |
| EU | - |
| Scholarships | - |

START OF THE PROJECT

2010

INFORMATION

D van der Meer
053 489 2387
d.vandermeer@utwente.nl

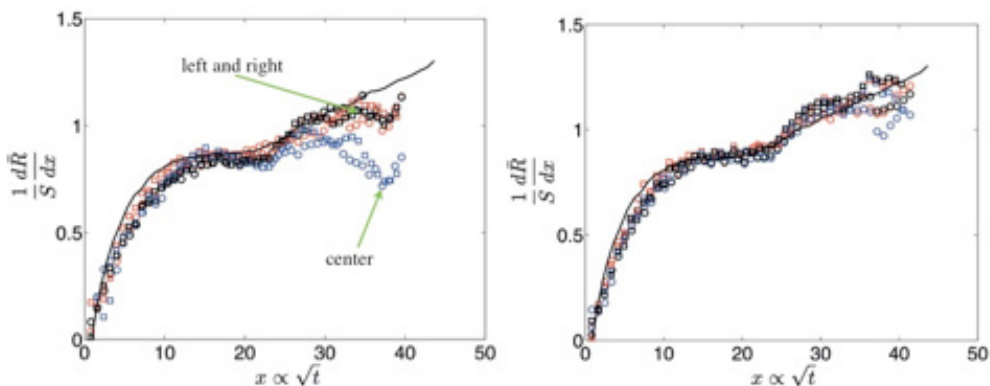

Growth rates of three bubbles growing next to each other from micro pits of radius = 10 μm , separated by 760 μm (left) and 1500 μm (right). S denotes the theoretical growth rate for a bubble growing by diffusion in an unbounded medium. The black lines show the growth rate of a single bubble growing under the same conditions. For the closer bubbles, the central one is clearly more disturbed than the ones at the extremes.

PROJECT LEADERS

HJW Zandvliet, D Lohse

RESEARCH THEME

Complex structures of fluids

PARTICIPANTS

P Bampoulis, E Dietrich,

RP Berkelaar, JH Weijs, ES Kooij

COOPERATIONS

XH Zhang (Melbourne University)

FUNDED

M2i, FOM

University 10 %

FOM 60 %

STW -

NWO Other -

Industry 30 %

TNO -

GTI -

EU -

Scholarships -

START OF THE PROJECT

2010

INFORMATION

D Lohse

053 489 8076

d.lohse@utwente.nl

pof.tnw.utwente.nl

PROJECT AIM

Surface nanobubbles are nano-scopic spherical capped gaseous bubbles at the solid-liquid interface. The nano-scopic scale should result in the dissolution of these bubbles within microseconds due to the enormous Laplace pressure. Remarkably, surface nanobubbles remain stable for hours up to days. The aim is to understand the mechanism behind this unexpected long-term stability and harness the properties of surface nanobubbles for new and exciting applications, e.g. enhancing slip in microchannels.

PROGRESS

The progress can be split into two parts, the theoretical contributions and experimental contributions. Theoretically, an important step has been taken in the understanding of the unexpected long-term stability of nanobubbles. The stability can be explained by 1) the retarded dissolution of gas molecules from the surface nanobubble through the liquid to the environment. And 2) by the assumption that surface nanobubbles are pinned. Therefore dissolution of gas from the bubbles results in a decrease in the radius of curvature and thus in a decrease in Laplace pressure. These two mechanisms combined slow the dissolution of surface nanobubbles down to several hours. Experimentally, progress has been made in the development of a procedure to distinguish between gaseous nanobubbles and nanobubble-like objects induced by contamination.

DISSERTATIONS

1. J.H. Weijs, Nanobubbles and nanodrops, thesis (2013).

SCIENTIFIC PUBLICATIONS

1. E. Dietrich, H.J.W. Zandvliet, D. Lohse, and J.R.T. Seddon, Particle tracking around surface nanobubbles, *J. Phys.: Condens. Matter* 25, 184009 (2013).
2. J.H. Weijs, and D. Lohse, Why Surface Nanobubbles Live for Hours, *PRL* 110, 054501 (2013).
3. R.P. Berkelaar, H.J.W. Zandvliet, and D. Lohse, Covering Surface Nanobubbles with a NaCl Nanoblanket, *Langmuir* 29, 11337 (2013).

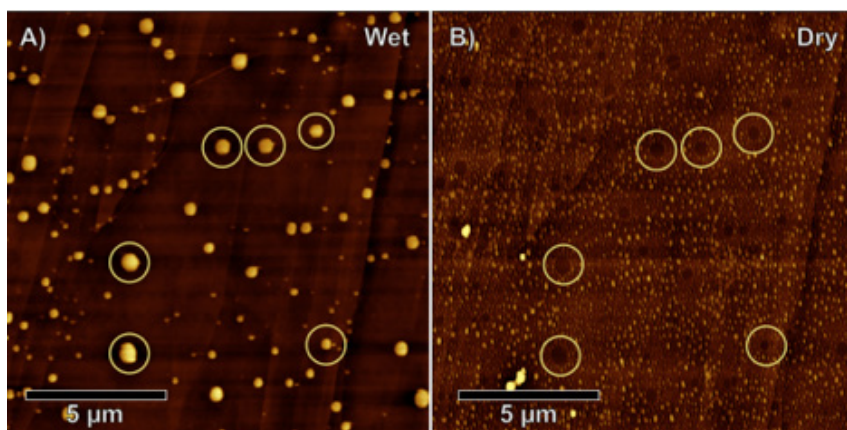

(A) Nanobubbles on HOPG in a 0.01 M NaCl solution. After injecting a NaCl solution, the surface is dried and the exact same area is imaged again. The dry HOPG surface is now covered with NaCl crystals, except for the positions nanobubbles had been present (B). The circles in both images (A,B) show a direct relation between nanobubble and the NaCl-deprived footprint. Evaporation time was approximately 11 h.

PROJECT AIM

The aim of the project is to provide fundamental understanding of fluid dynamics in EUV sources in order to increase the conversion efficiency of the next generation lithography machines. Topics of this work include droplet generation, coalescence dynamics, target shaping, plasma droplet interaction, interaction of gas flows with droplet trajectory, process stability and splashing. The project has an experimental focus, supported by theory and numerical modeling.

PROGRESS

A basic droplet generation setup with imaging system has been build. The results have led to a paper which is submitted to JFM. Current work focuses on stability of droplettrains and airdrag. This work also has a numerical component.

DISSERTATIONS

-

SCIENTIFIC PUBLICATIONS

-

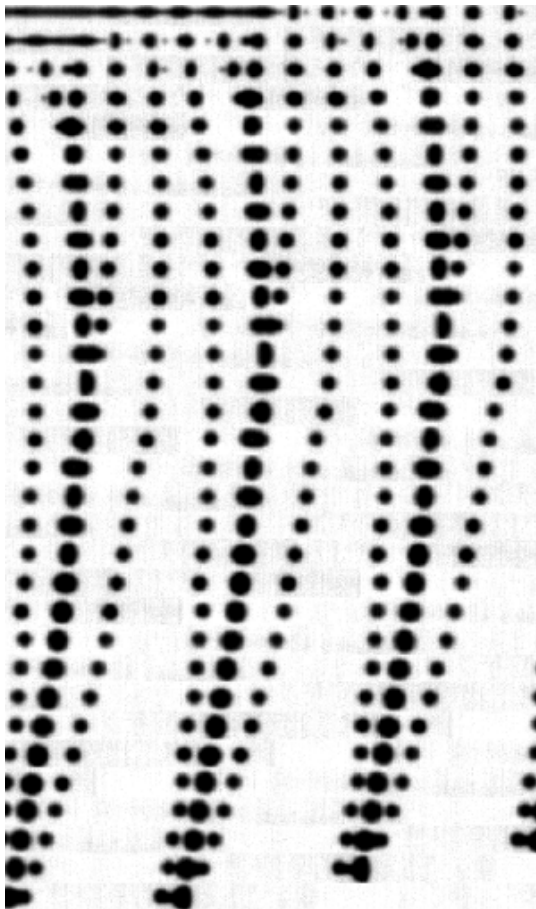

PROJECTLEADERS

D Lohse, JF Dijkman, M Versluis

RESEARCHTHEME

Complex dynamics of fluids

PARTICIPANTS

P Sleutel

COOPERATIONS

Ramin Badie, Jos Benschop (ASML)

Herman Wijshof (Océ, NanonextNL)

FUNDED

NanonextNL

University -

FOM -

STW -

NWO Other 100 %

Industry -

TNO -

GTI -

EU -

Scholarships -

START OF THE PROJECT

2012

INFORMATION

P Sleutel

073 486 4213

c.p.sleutel@utwente.nl

<http://pof.tnw.utwente.nl>

The image shows the coalescence process of droplets created by a high speed jet. The coalescence process is fully controlled from the nozzle by imposing two Rayleigh-Plateau instabilities. The images are recorded stroboscopically at regular time intervals and every image is shifted one period in the direction of the jetvelocity in order to create this space time plot. The influence of airdrag is clearly visible from the bending of the droplet trajectories.

SELF-RESONATING NOZZLES

PROJECT LEADERS

M Versluis, D Lohse

RESEARCH THEME

Complex dynamics of fluids

PARTICIPANTS

M Kok, P J van Dijk, N Tas

COOPERATIONS

J Wissink (Medspray)

FUNDED

NanoNextNL

University -

FOM -

STW -

NWO Other 100 %

Industry -

TNO -

GTI -

EU -

Scholarships -

START OF THE PROJECT

2013

INFORMATION

M Versluis

053 489 3084

m.versluis@utwente.nl

PROJECT AIM

Micron sized droplets may be produced by pressing liquid at high pressure through an orifice to induce a liquid jet. The liquid jet subsequently breaks up by the Rayleigh instability into droplets that have a narrow size distribution.

This mechanism is successfully used in practical applications such as inkjet printing and medical applications, such as drug inhalers and eye sprays. The aim of this project is to control the breakup process by passive, flow induced, triggering or manipulation of this instability. Controlling breakup processes facilitates the manipulation of jet breakup length and drop size.

PROGRESS

The dynamics of non-circular jets has been studied analytically, as well as the influence of axis-switching jet oscillations on the jet breakup rate compared to circular jets.

DISSERTATIONS

-

SCIENTIFIC PUBLICATIONS

-

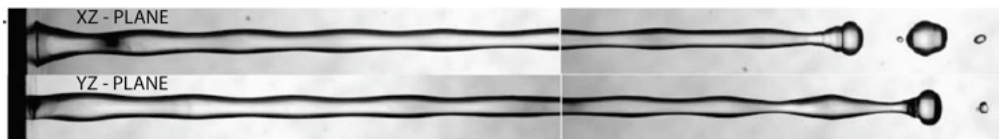

Kasyap et al., *Int. J. Multiphase Flow* 35, 8-19 (2009)

TURBULENT AND BOILING TAYLOR-COUPETTE FLOWS

PROJECT AIM

Taylor-Couette (TC) is the flow between two coaxial, independently rotating cylinders. As it is a closed system, global transport balances can be established, which give more insight into the fundamental behavior of the flow, as they reflect the interplay of bulk and boundary layer. We experimentally investigated the boundary layer properties in the ultimate TC regime, and quantitatively compare it to other flow-systems. Furthermore, we statistically described the properties of the turbulent flow by studying the structure functions of the velocity fluctuations at different rotations. We are building a new TC facility that incorporates boiling and high-precision temperature control, aiming to study the fundamentals of boiling in turbulence.

PROGRESS

Using the experimental data we published a PRL and a PRE paper, and other publications are submitted or in preparation. In addition, we have nearly completed the construction of the BTTC (Boiling Twente Taylor-Couette).

DISSERTATIONS

-

SCIENTIFIC PUBLICATIONS

1. S.G. Huisman, D. Lohse, and C. Sun. Statistics of turbulent fluctuations in counter-rotating Taylor-Couette flows. *Phys. Rev. E* 88, 063001 (2013).
2. S.G. Huisman, S. Scharnowski, C. Cierpka, C.J. Kähler, D. Lohse, and C. Sun. Logarithmic Boundary Layers in Strong Taylor-Couette Turbulence. *Phys. Rev. Lett.* 110, 264501 (2013).

PROJECT LEADERS

D Lohse, C Sun

RESEARCH THEME

Complex dynamics of fluids

PARTICIPANTS

S Huisman, R van der Veen, C Sun, D Lohse

COOPERATIONS

-

FUNDED

Simon Stevin
 ERC advanced grant
 University -
 FOM -
 STW 50 %
 NWO Other -
 Industry -
 TNO -
 GTI -
 EU 50 %
 Scholarships -

START OF THE PROJECT

2010

INFORMATION

D Lohse
 053 489 8076
 d.lohse@utwente.nl
 pof.tnw.utwente.nl



Boiling BTTC facility

Boundary layers with logarithmic features.

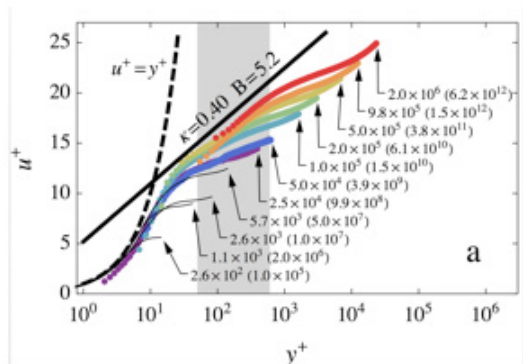

ENHANCED CONTRAST AND MOLECULAR IMAGING FOR ULTRASOUND BASED MEDICAL IMAGING TECHNIQUES

PROJECT LEADERS

JH Snoeijer

RESEARCH THEME

Complex dynamics of fluids

PARTICIPANTS

A Eddi, W Bouwhuis, JF Hernandez-Sanchez, K Winkels, J Weijs

COOPERATIONS

-

FUNDED

NWO VIDU, Lam Research

University -

FOM -

STW -

NWO Other 80 %

Industry 20 %

TNO -

GTI -

EU -

Scholarships -

START OF THE PROJECT

2011

INFORMATION

JH Snoeijer

053 489 3085

j.h.snoeijer@utwente.nl

http://pof.tnw.utwente.nl

PROJECT AIM

The project aims at improving the imaging capabilities of existing medical ultrasound technologies by means of contrast agents. The physical processes by which contrast agents based on solid nano and microparticles, superheated droplets and enriched microbubble suspensions enhance the contrast is investigated. For therapeutic applications the interaction of the agents with living cells is addressed.

PROGRESS

A micrometer capsule based photoacoustic agent with a medical relevant sensitivity was developed and characterized. Solid nanoparticles being acoustically active and visible in MRI were thoroughly characterized and were shown to be an excellent multimodal contrast agent. The physical mechanism of acoustic droplet vaporization was revealed. We have shown that the droplet sphere focuses the ultrasound wave as an optical lens focuses light. Moreover, following activation, the physics of the vapor bubble expansion is shown to be heat transfer limited. The air diffusion present during the vaporization process can prevent the collapse of newly created vapor bubbles, when external conditions are changed to favor the re-condensation. Finally, acoustically enriched microbubble contrast agents were shown to increase the sensitivity of contrast enhanced ultrasound imaging through a fivefold increased scattering to attenuation ratio.

DISSERTATIONS

-

SCIENTIFIC PUBLICATIONS

1. Ultrafast dynamics of the acoustic vaporization of phase-change microdroplets, O. Shpak, Tom J. A. Kokhuis, Y. Luan, D. Lohse, N. de Jong, B. Fowlkes, M. Fabiilli and M. Versluis, *J. Acoust. Soc. Am.* 134 (2013).
2. The role of gas in ultrasonically driven vapor bubble growth, O. Shpak, Laura Stricker, Michel Versluis, and Detlef Lohse, *Phys. Med. Biol.* 58 (2013).

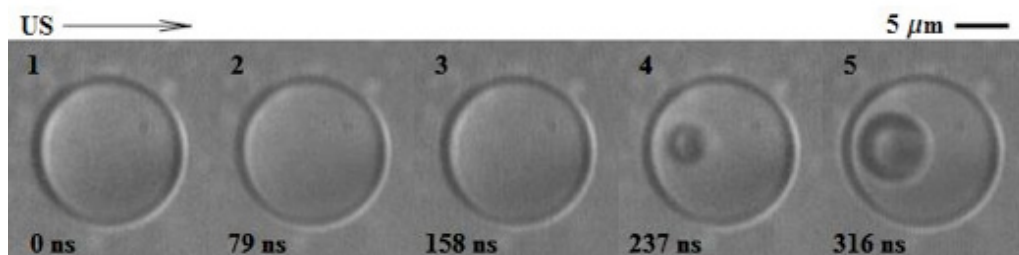

A set of consecutive images showing acoustic droplet vaporization of a 7.4- μm -radius droplet taken at a frame rate of 12.6 million frames per second. The droplet is triggered by an eightcycle, 5-MHz frequency ultrasound pulse. The nucleation is initiated between frames 3 and 4. Frames 4 and 5 show the subsequent vapor bubble growth

UNDERSTANDING THE SPATIO-TEMPORAL STRUCTURE OF HIGHLY INTERMITTENT TURBULENT FLOW IN WIND FARMS: HOW TO DEAL WITH LARGE FLUCTUATIONS?

PROJECT AIM

In this project we use large eddy simulations to model the interaction between wind farms with many turbine rows in the downstream direction and the atmospheric boundary layer. We focus on the effect of the layout of the wind farm on its total power output and power fluctuations. We want to understand the influence of the properties of the very large-scale motions in the atmospheric boundary layer and the role of the turbulent fluctuations on the wind farm performance. Subsequently we want to translate this understanding to simpler models that can be used to predict properties of extended wind farms.

PROGRESS

We have developed a new concurrent precursor method that allows us to study finite size wind-farms. This approach allows a realistic representation of the time resolved structures in the atmospheric boundary layer, which are difficult to include in synthetic models. The method is computationally efficient as no database is required. We used this technique to simulate the efficiency of several wind-farm configurations. We find that a perfectly staggered (checkerboard) configuration does not necessarily give the highest average power output. Instead, the highest mean power output is found to depend on several factors, the most important one being the alignment that leads to minimization of wake effects from turbines just upstream [2]. The LES results have also been used to improve a simple 'momentum balance' based theory to predict the power development as function of the main wind-farm design parameters such as the turbine spacing.

DISSERTATIONS

-

SCIENTIFIC PUBLICATIONS

1. R.J.A.M. Stevens, D. F. Gayme, C. Meneveau, Effect of turbine alignment on the average power output of wind farms, International Conference on Aerodynamics of Offshore Wind Energy Systems and Wakes (ICOWES2013), 611-623 (2013).
2. C. Archer et al., Meteorology for coastal/offshore wind energy in the US: Research needs for the next 10 years Bull. Am. Meteorol. Soc. (BAMS) (2013), <http://dx.doi.org/10.1175/BAMS-D-13-00108.1>.

PROJECT LEADERS

RJAM Stevens

RESEARCH THEME

Complex dynamics of fluids

PARTICIPANTS

Prof. C. Meneveau (Johns Hopkins University, USA), Prof. D.F. Gayme (Johns Hopkins, USA), Dr. M. Wilczek (Johns Hopkins, USA)
Tony Martinez (Johns Hopkins, USA)

COOPERATIONS

-

FUNDED

| | |
|--------------|------|
| University | - |
| FOM | 50 % |
| STW | - |
| NWO Other | - |
| Industry | 50 % |
| TNO | - |
| GTI | - |
| EU | - |
| Scholarships | - |

START OF THE PROJECT

2012

INFORMATION

R Stevens
053 489 2487
+1 (410) 516-6780
r.j.a.m.stevens@utwente.nl

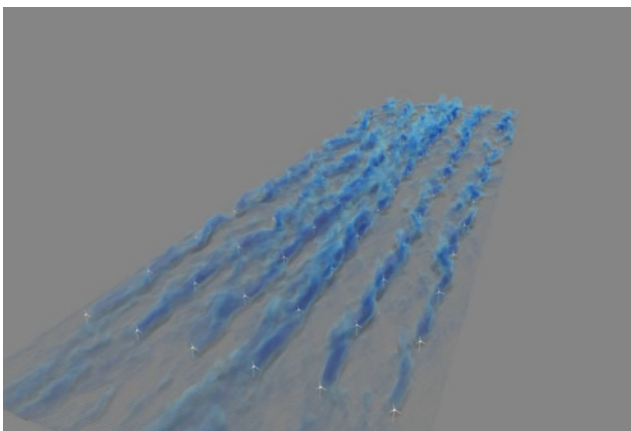

Visualization of the low speed wind regions indicated in blue in a very large wind-farm which shows the creation of turbulent wakes behind the turbines (visualization by David Bock, NCSA Visualization, XSEDE)

PROJECT LEADERS

D Lohse, R Verzicco

RESEARCH THEME

Complex dynamics of fluids

PARTICIPANTSRJAM Stevens, R Lakkaraju,
EP van der Poel, R Ostilla Monico,
V Spandan, Y Yang**COOPERATIONS**

TU/E, BTU Cottbus, Shell, UCSB

FUNDED

FOM, ERC

University 25 %

FOM 75 %

STW -

NWO Other -

Industry -

TNO -

GTI -

EU -

Scholarships -

START OF THE PROJECT

2012

INFORMATION

EP van der Poel

053 489 2487

e.p.vanderpoel@utwente.nl

<http://pof.tnw.utwente.nl/>**PROJECT AIM**

Turbulent convection is the most common flow in Nature. Examples include flow in the atmosphere, oceans, the inner core of the earth, giant gas planets and the outer layer of the sun. Rayleigh-Bénard convection, the fluid flow between two plates, cooled from above and heated from below, serves as a simple model system for industrial and geophysical systems. In this project we will try to understand through direct numerical simulations the different regimes of turbulent convection which arise when very strong drivings, a second phase (also including phase changes), rotation, or two distinct driving components are present in the flow.

PROGRESS

Simulations of bubbly thermal convection were done, and the heat transport enhancement associated to phase changes seen in experiments was correctly predicted, and understood. 2D simulations were also compared to 3D ones, and the differences between them were elucidated. An experimental DNS code with a 2D MPI parallelization which scales up to hundreds of thousands of cores was developed. This code was also extended to simulate various configurations, such as deformable bubbles, or convection driven by salinity and temperature differences. A multiple spatial and temporal resolution scheme was developed to solve flows with extreme Prandtl numbers.

DISSERTATIONS

1. Rajaram Lakkaraju, PhD Thesis: Boiling Turbulent Rayleigh-Bénard Convection

SCIENTIFIC PUBLICATIONS

1. Poel, E.P. van der, Stevens, R.J.A.M. & Lohse, D. Comparison between two- and three-dimensional Rayleigh-Bénard convection. *J. Fluid Mech.* 736, 177 (2013).
2. Stevens, R.J.A.M., Poel, E.P. van der, Grossmann, S. & Lohse, D. The unifying theory of scaling in thermal convection: the updated prefactors. *J. Fluid Mech.* 730, 295 (2013).
3. Ostilla Monico, R., Stevens, R.J.A.M., Grossmann, S., Verzicco, R. & Lohse, D. Optimal Taylor-Couette flow: direct numerical simulations. *J. Fluid Mech.* 719, 14 (2013).
4. Lakkaraju, R., Stevens, R.J.A.M., Oresta, P., Verzicco, R., Lohse, D. & Prosperetti, A. Heat transport in bubbling turbulent convection. *PNAS* 110, 9237 (2013).

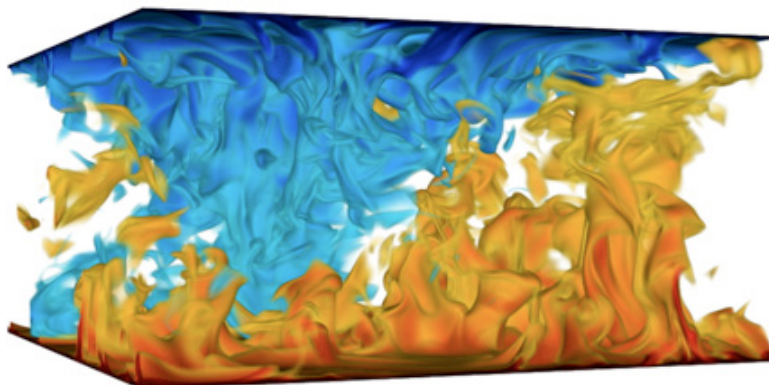

IMPACT OF RAIN DROPS ON SAND

PROJECT AIM

The impact of a liquid droplet on a layer of grains is amongst the most common events in nature. Nevertheless, surprisingly little is known about the physics that governs it. First, we want to know what causes sand and water to mix during impact? Second, when there is no mixing, what controls the amount of momentum that is transferred from the liquid to the sand? Third, how can we understand the different crater shapes that are generated? With experimental work we want to resolve these questions.

PROGRESS

In 2013, we developed our setup, such that we can measure not only the crater diameter, but also its depth and deformation. We measure it both dynamically during impact (by two laser lines) and statically after impact, for which we scan the sample to obtain the full 3D crater shape. The results indicate that the crater diameter will decrease when impact velocity is decreased or the packing of the grains is made denser. The crater depth will decrease tremendously when the sand bed is compactified.

DISSERTATIONS

-

SCIENTIFIC PUBLICATIONS

-

PROJECT LEADERS

D van der Meer

RESEARCH THEME

Complex dynamics of fluids

PARTICIPANTS

R de Jong, S Zhao

COOPERATIONS

-

FUNDED

-

University -

FOM -

STW -

NWO Other 100 %

Industry -

TNO -

GTI -

EU -

Scholarships -

START OF THE PROJECT

2012

INFORMATION

D van der Meer

053 489 2387

d.vandermeer@utwente.nl

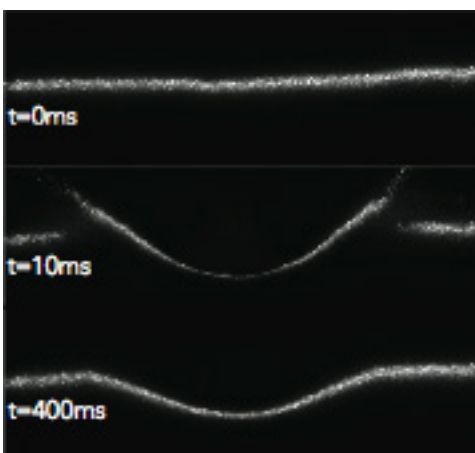

The dynamic measurement of the crater (only one line shown)

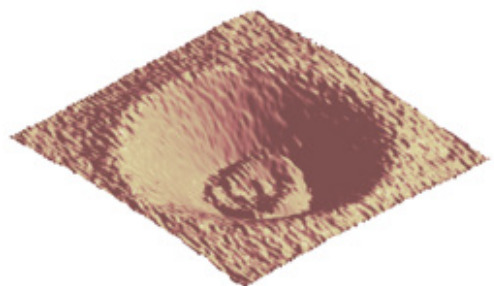

The static, full 3D image of the crater

PROJECT LEADERS

M Versluis

RESEARCH THEME

Complex dynamics of fluids

PARTICIPANTS

L van der Sluis, B Verhaagen,
C Boutsoukis, R Macedo, L-M Jiang,
D Fernandez Rivas

COOPERATIONS

Academic Center for Dentistry
Amsterdam, University Medical
Center Groningen, Dental School
University of Birmingham (UK)

FUNDED

STW
University -
FOM -
STW 100 %
NWO Other -
Industry -
TNO -
GTI -
EU -
Scholarships -

START OF THE PROJECT

2007

INFORMATION

M Versluis
053 489 6824
m.versluis@utwente.nl

Pattern of nodes and antinodes set up along an endodontic file for various location of contact between the file and a wall. Each line represents a phase of 20 degrees. The red line indicates the oscillation of an unconstrained file. The file is driven at the top

PROJECT AIM

Ultrasonic irrigation of the root canal is found to be much more efficient than conventional root canal irrigation using a syringe and needle, after which bacteria often remain, leading to persistent infection. Why ultrasonic irrigation is more effective is not known, however. Through high-speed visualizations and numerical simulations (CFD) we try to elucidate the cleaning mechanisms (streaming, cavitation, or other mechanisms) involved in root canal cleaning, with the final goal of improving root canal irrigation even more.

PROGRESS

The project has come to an end after a last batch of articles on the occurrence and contribution of cavitation to ultrasonic irrigation. The introduction of a biofilm-mimicking hydrogel has allowed for a quantification of the contribution of both streaming and cavitation to the removal of a viscoelastic material from root canal ramifications. The validation of a full two-way coupled three-dimensional model of ultrasonic irrigation is well under way. Together with a major manufacturer of dental instruments we have investigated various possibilities for improving the existing endodontic equipment. Some new designs have been complemented with experiments. The thermodynamics of pre-heated irrigant injected into the root canal has been investigated as another method for enhancing the chemical aspect of root canal irrigation.

DISSERTATIONS

1. 'Optimizing the chemical aspect of root canal irrigation' Dr. Ricardo Macedo (ACTA).

SCIENTIFIC PUBLICATIONS

1. Liang, Y.-H., Jiang, L.-M., Jiang, L., Chen, X.-B., Liu, Y.-Y., Tian, F.-C., Bao, X.-D., Gao, X.-J., Versluis, M., Wu, M.-K., Van Der Sluis, L. Radiographic healing after a root canal treatment performed in single-rooted teeth with and without ultrasonic activation of the irrigant: A randomized controlled trial (2013) Journal of Endodontics 39(10), pp. 1218-1225.
2. Boutsoukis, C., Verhaagen, B., Walmsley, A.D., Versluis, M., van der Sluis, L.W.M., "Measurement and visualization of the occurrence of contact during Passive Ultrasonic Irrigation", (2013) International Endodontic Journal 46(11), pp. 1046-1055.
3. A. R. Özok, B. Verhaagen, and P. R. Wesselink, "Improving the accuracy of a fluid transport method," International Endodontic Journal, vol. 46, no. 4, pp. 348–354, 2013.

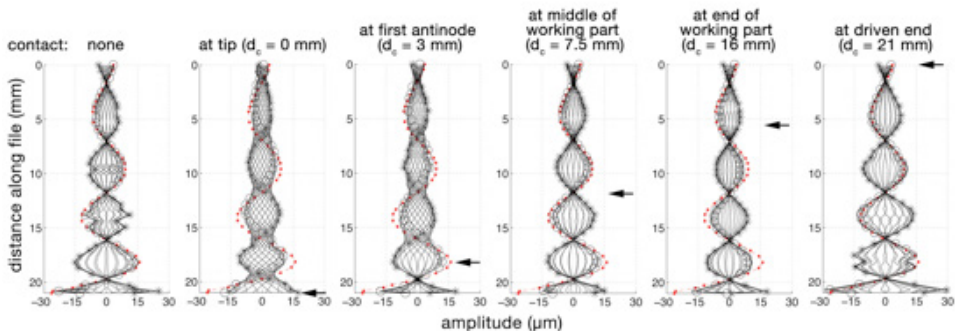

MARANGONI SPREADING ON THIN LIQUID SURFACES

PROJECT AIM

The aim of the project is to understand the dynamics of a growing rim produced by the continuous addition of a miscible liquid with a different surface tension to a water layer of controlled thickness deposited on a hydrophilic surface. This problem is inspired from an industrial process in which scales are greater.

PROGRESS

During 2013 the experimental device was assembled and became operational, a scaling argument explaining the phenomena was proposed and tested, leading to paper submitted to Journal of Fluid Mechanics.

DISSERTATIONS

1. Wolter van der Velde, Master in science, August 2013.

SCIENTIFIC PUBLICATIONS

-

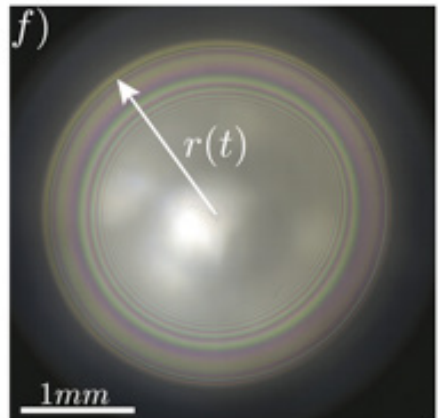
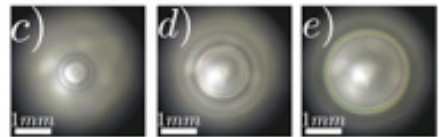
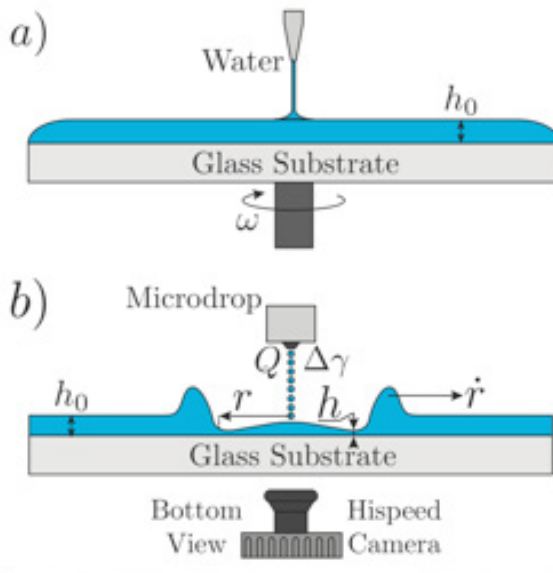
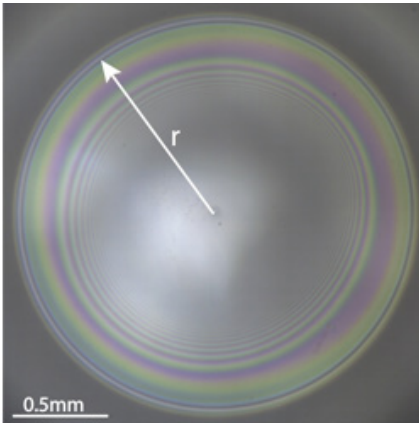

PROJECT LEADERS

JH Snoeijer, D Lohse

RESEARCH THEME

Complex dynamics of fluids

PARTICIPANTS

JF Hernández-Sánchez, A Eddi,

W van der Velde

COOPERATIONS

-

FUNDED

Lam Research

University -

FOM -

STW -

NWO Other -

Industry 100 %

TNO -

GTI -

EU -

Scholarships -

START OF THE PROJECT

2012

INFORMATION

JF Hernández-Sánchez

053 489 4682

j.f.hernandezsanchez@utwente.nl

<http://stilton.tnw.utwente.nl/people/snoeijer/>

snoeijer/

PROJECT LEADERS

D Lohse, JH Snoeijer, FJ Dijkman

RESEARCH THEME

Complex dynamics of fluids

PARTICIPANTS

MJ Thoraval, E Sandoval

COOPERATIONS

Holst Center, Dutch Polymer Institute

FUNDED

Holst Center, Dutch Polymer Institute

University -

FOM -

STW -

NWO Other -

Industry 50 %

TNO 50 %

GTI -

EU -

Scholarships -

START OF THE PROJECT

2012

INFORMATION

D Lohse

053 489 8076

d.lohse@utwente.nl

<http://pof.tnw.utwente.nl>

PROJECT AIM

Inkjet printing is considered the contender of choice for the manufacturing of low-cost and large-area electronics, such as for disposable medical devices, radio-frequency applications for theft protection in shops, polymer LED based lighting devices, or solar cells. The idea is to make these devices on roll-to-roll equipment: the components of the electronic structures are deposited by means of inkjet printing, which can be scaled to any deposition rate by adding either extra nozzles or extra print heads and to adjust the droplet volume.

PROGRESS

The last meeting has oriented the efforts of the last period on two main targets:

- Explore the possibility of using jetting as a rheometer. Indeed, the high shear rates encountered in the jetting are not accessible with conventional rheometers.

- Investigate the splashing – non-splashing transition of silver nano-suspension when increasing the droplet impact velocity. This behavior is very surprising and was not reported before. It will help us understand the physics of splashing.

DISSERTATIONS

-

SCIENTIFIC PUBLICATIONS

-



PROJECT AIM

The aim of the project is to study the lagrangian statistics of rigid light particle in homogeneous isotropic turbulence. We plan to exhaustively map out the behavior of light particles from small to large Galileo numbers by systematically varying the density and size ratios. The final aim of the project is to determine the transition regime when light particle behavior in turbulence begins to get dominated by vortex shedding effects.

PROGRESS

Behavior of light rigid particles in Turbulence is being explored. Preliminary results have shown that light particle behave differently from the well-explored neutrally buoyant and heavy particles. We have found that path Instabilities and vortex-induced motions play a dominant role in lagrangian statistics of light particles in turbulence.

DISSERTATIONS

1. Light Particles in Turbulence- PhD Thesis, Vivek N Prakash. Finite-sized Particles in the Twente Water Tunnel: Spheres and Fibers, MSc Thesis, Tobias Foertsch.

SCIENTIFIC PUBLICATIONS

1. The clustering morphology of freely rising deformable bubbles JOURNAL OF FLUID MECHANICS Tagawa, Y., Roghair, I., Prakash, V. N., Annaland, M. v., Kuipers, H., Sun, C., Lohse, D.2013; 721.
2. Energy spectra in bubbly turbulence, Vivek N. Prakash, J. M. Mercado, F. E. M. Ramos, Y. Tagawa, D. Lohse and C. Sun, (2013). [arXiv].

PROJECT LEADERS

D Lohse, C Sun

RESEARCH THEME

Complex dynamics of fluids

PARTICIPANTS

V Mathai, VN Prakash

COOPERATIONS

AKZO-Nobel, Corus, DSM, Shell,

Prof. J.A.M. Kuipers TU/e, Prof.

Federico Toschi TU/e, Dr. E.

Calzavarini, Dr. Y. Tagawa, Dr. J.M.

Mercado, Dr. I. Roghair, Dr. M. v.

Sint-Annaland, F. E. M. Ramos

FUNDED

EuHIT, J. M. Burgerscentrum, FOM,

COST MP0806

University -

FOM -

STW -

NWO Other -

Industry 100 %

TNO -

GTI -

EU -

Scholarships -

START OF THE PROJECT

2007

INFORMATION

C Sun

053 489 5604

c.sun@utwente.nl

[http:// pof.tnw.utwente.nl](http://pof.tnw.utwente.nl)

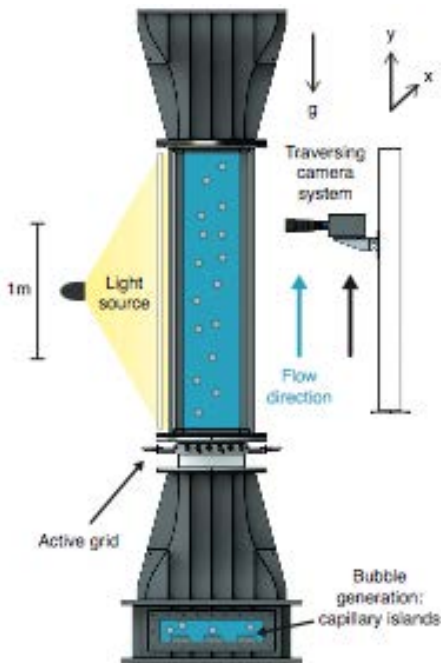

FUNDAMENTAL FLUID DYNAMICS CHALLENGES OF EXTREME ULTRAVIOLET LITHOGRAPHY

PROJECT LEADERS

D Lohse, J Snoeijer, C Sun,
H Gelderblom, FJ Dijkman

RESEARCH THEME

Complex dynamics of fluids

PARTICIPANTS

H Gelderblom, MV Gielen, AL Klein,
D Lohse, JH Snoeijer, C Sun,
JF Dijkman

COOPERATIONS

Villiermaux, Université Aix-Marseille
Lhuissier, Université Paris-Diderot
Venner, University of Twente
ASML Research

FUNDED

| | |
|--------------|------|
| FOM & ASML | - |
| University | - |
| FOM | 50 % |
| STW | - |
| NWO Other | - |
| Industry | 50 % |
| TNO | - |
| GTI | - |
| EU | - |
| Scholarships | - |

START OF THE PROJECT

2013

INFORMATION

H Gelderblom
053 489 5955
h.gelderblom@utwente.nl
<http://stilton.tnw.utwente.nl/people/gelderblom/>

PROJECT AIM

A method to generate Extreme Ultraviolet (EUV) light is to ionize liquid tin drops by a laser pulse. The resulting hot plasma emits EUV radiation. Several of the challenges to make this method operational have their origin in contemporary fluid physics. Here, we focus on two of these fluid dynamics challenges. First, we study the deformation and fragmentation of liquid drops upon impact of a laser pulse. Second, we want to define the criteria for the splashing and bouncing of liquid drops on soft (visco-)elastic substrates and the role of heat transfer and liquid solidification during impact.

PROGRESS

The first two PhD students in this FOM-IPP program have now started and the experimental facilities at ASML are being set up. Preliminary experiments of laser impact on liquid tin drops have been performed, and a set-up for the study of laser impact on dyed water drops has been realized. Furthermore, a theoretical framework for the study of drop deformation and fragmentation by laser impact has been created. For the impact project, first experiments with ethanol drops on a visco-elastic substrate have been performed. A combined theoretical and numerical approach is used to further investigate substrate- and drop deformation during impact on a soft substrate.

DISSERTATIONS

-

SCIENTIFIC PUBLICATIONS

-

Caption: Time series of a liquid tin drop that is hit by a laser pulse. Images obtained with stroboscopic illumination with a 20-ns exposure time. Each image is exposed twice to freeze the drop in its initial and a later state in time.

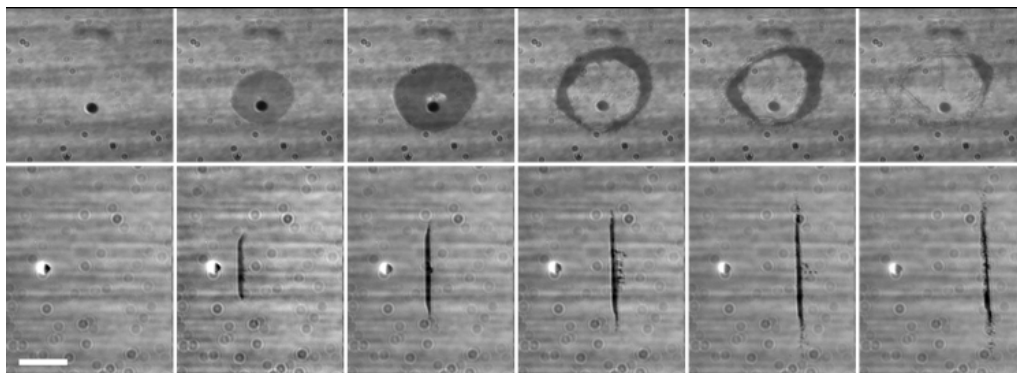



Prof.dr. F Mugele

MISSION

The goal of the PCF group is to understand and control the structure and the mechanical properties of liquids and interfaces on length scales ranging from molecular to submillimeter scales. The activities fall in three main categories: i) nanofluidics, ii) (electro)wetting & microfluidics, iii) soft matter mechanics. Our nanofluidics research focuses on understanding the range of validity of macroscopic continuum physics and in its breakdown upon approaching molecular scales, where physico-chemical aspects become increasingly important. In microfluidics, many properties of fluids, in particular drops, are controlled by interfacial effects. By patterning surfaces and in particular by making use of the electrowetting effect we control the shape, the motion, and the generation of microdrops. These processes involve various challenging fundamental issues, such as contact angle hysteresis, the dynamics of contact lines, and hydrodynamic singularities. The soft matter mechanics activities focus on correlations between the internal structure of various types of complex fluids ranging from colloidal suspensions to living cells and their macroscopic viscous and elastic properties.

By improving the physical understanding of fundamental phenomena we contribute to the improvement of various technological processes involving fluid motion on small scales, including oil recovery, immersion lithography, and inkjet printing. This work is frequently carried out in collaboration with industrial partners including BP, Shell, ASML, Océ, Liquavista, sometimes within government sponsored consortia such as FOM-IPPs, sometimes in direct collaboration. A major project on enhanced oil recovery started in late 2009 and became fully operational in 2010. In this context, the group intensified its activities in the area of physical chemistry of liquid-liquid and solid-liquid interfaces. In late 2010, Prof. Mugele obtained a NWO-VICI grant to investigate the properties of superhydrophobic surfaces that are functionalized by electric fields. One major goal of the project is to explore various applications of such smart surfaces for microfluidics, ultrasound detection, and in particular optofluidics.

CONTACT LINE CONTROL DURING WETTING AND DEWETTING

PROJECT AIM

The goal of the project is to explore the use of electrowetting to manipulate moving drops on solid surfaces and to understand the interaction of drops with heterogeneities such as topographic and chemical defects on surfaces, with specific emphasis on the relevance for immersion lithography.

PROGRESS

2013 was devoted to the completion of the project. 3 articles and the PhD thesis were published (see below) and a fourth publication was submitted and is about to appear in Nature Communications. Progress in 2013 was focused on the development of electrically tunable wetting defects as a tool for fundamental understanding of wetting processes as well as modeling of various aspects of dynamic wetting. In particular, we could demonstrate that the trapping of moving drops is governed by subtle balance of surface tension forces, driving forces (gravity, viscous drag), and drop inertia.

DISSERTATIONS

1. Mannetje, D.J.C.M. 't (2013, september 05). Drops, contact lines, and electrowetting. UT Universiteit Twente (172 pag.) (Enschede, the Netherlands). Prom./coprom.: Prof.dr. F. Mugele & Dr. H.T.M. van den Ende.

SCIENTIFIC PUBLICATIONS

1. Eral, H.B., Mannetje, D.J.C.M. 't & Oh, J.M. (2013). Contact angle hysteresis: a review of fundamentals and applications. *Colloid and polymer science*, 291, 247-260.
2. Mannetje, D.J.C.M. 't, Banpurkar, A.G., Koppelman, Helmer, Duits, M.H.G., Ende, D. van den & Mugele, F. (2013). Electrically Tunable Wetting Defects Characterized by a Simple Capillary Force Sensor. *Langmuir*, 29(31), 9944-9949.
3. Mannetje, D.J.C.M. 't, Mugele, F. & Ende, D. van den (2013). Stick-slip to sliding transition of dynamic contact lines under AC electrowetting. *Langmuir*, 29(48), 15116-15121.

PROJECT LEADERS

F Mugele, D van den Ende

RESEARCH THEME

Complex dynamics of fluids

PARTICIPANTS

DJCM 't Mannetje

COOPERATIONS

TU/e (Darhuber group), ASML; Océ

FUNDED

| | |
|----------------|------|
| FOM, ASML, Océ | |
| University | - |
| FOM | 50 % |
| STW | - |
| NWO Other | - |
| Industry | 50 % |
| TNO | - |
| GTI | - |
| EU | - |
| Scholarships | - |

START OF THE PROJECT

2008

INFORMATION

F Mugele
053 489 2106
f.mugele@utwente.nl
www.utwente.nl/tnw/pcf

PROJECT LEADERS

F Mugele, D van den Ende

RESEARCH THEME

Complex dynamics of fluids

PARTICIPANTS

D Mampallil Augustine

COOPERATIONS

-

FUNDED

MicroNed

University -

FOM -

STW -

NWO Other -

Industry -

TNO -

GTI -

EU 100 %

Scholarships -

START OF THE PROJECT

2009

INFORMATION

F Mugele

053 489 2106

f.mugele@utwente.nl

www.utwente.nl/tnw/pcf

PROJECT AIM

Original goal of this project was to develop a microrheometer based on microfluidic channels for ultrasoft materials (e.g. gels). The idea was to generate shear flows based on electroosmosis. By tuning the surface charge using gate electrodes, the strength of the shear flow should be controllable.

PROGRESS

In 2013, a number of residual projects from the 2012 PhD thesis of Dileep Mampallil were published. The first two papers (see below) shed light on the dynamics of drops that are driven by time-periodic excitation with electrowetting, for the case of quasi-two-dimensional 'sandwich' drops and for three-dimensional sessile drops on planar substrates. In the latter case, strong internal flow fields can be induced with a symmetry in the azimuthal plane that can be controlled by placing a well-defined number of wetting defects along the contact line. The third publication aims at the use of microfluidic devices as microrheometers with electrokinetically controlled shear flows..

DISSERTATIONS

-

SCIENTIFIC PUBLICATIONS

1. Electrowetting driven oscillating drops sandwiched between two substrates
Dileep Mampallil, H. Burak Eral, Adrian Staicu, Frieder Mugele and Dirk van den Ende. Phys. Rev. E 88 (2013) 053015: 1-8.
2. Sample pre-concentration inside sessile droplets using electrowetting
Dileep Mampallil, Dharendra Tiwari, Dirk van den Ende and Frieder Mugele
Biomechanics 7 (2013) 044102: 1-8.
3. Electroosmotic shear flow in microchannels. Dileep Mampallil and Dirk van den Ende, J. Coll. Int. Sci. 390 (2013) 234-241.

MODELLING AND SIMULATION OF ELECTROWETTING AND MICROFLUIDICS SYSTEMS

PROJECT AIM

The aim of the project is to provide modelling and numerical simulations for the different microfluidics projects in the PCF group, as well as for the electrowetting research carried out at the partner company Liquavista. The main objective is the development and maintenance of a multiphysics openFoam code to simulate electrowetting phenomena, a research started by a former postdoc in the PCF group, Ivo Roghair. Parallel activities involve the development of models for wetting on textured surfaces, optofluidics and acoustofluidics devices, tailored on ongoing experimental research in the group.

PROGRESS

An openFoam model describing droplets sliding over wetting defects of tunable strength and shape was developed and validated. We started comparing it with experiments on electrowetting trapping of droplets, previously carried out by former Ph.D. student Dieter 't Mannetje. In collaboration with Gor Manukyan at Liquavista, I tested the openFoam model of an electrowetting pixel previously developed by Ivo Roghair. We then extended it to account for different designs (geometry of the pixel, electrode positioning). In collaboration with the Ph.D. Student Bijoyendra Bera, I developed a Comsol implementation of the Poisson-Boltzmann equation for a mica-oil-water system, which has been experimentally observed to show a wetting transition upon the addition of divalent ions.

DISSERTATIONS

-

SCIENTIFIC PUBLICATIONS

-

PROJECT LEADERS

F Mugele

RESEARCH THEME

Mathematical and computational methods for fluid flow analysis

PARTICIPANTS

A Cavalli, G Manukyan, B Bera

COOPERATIONS

Liquavista

FUNDED

| | |
|-----------------|------|
| Liquavista, STW | |
| University | - |
| FOM | - |
| STW | 50 % |
| NWO Other | - |
| Industry | 50 % |
| TNO | - |
| GTI | - |
| EU | - |
| Scholarships | - |

START OF THE PROJECT

2013

INFORMATION

A Cavalli
053 489 3093
a.cavalli@utwente.nl
www.utwente.nl/tnw/pcf

PROJECT LEADERS

F Mugele, D van den Ende

RESEARCH THEME

Complex dynamics of fluids

PARTICIPANTS

J de Ruiter

COOPERATIONS

HIPRINS consortium

FUNDED

Dutch Ministry of Economic Affairs, Agriculture and Innovation, the provinces Overijssel, Limburg, and Noord-Brabant, and cityregion Eindhoven (SRE)

University -

FOM -

STW -

NWO Other -

Industry -

TNO -

GTI -

EU 100 %

Scholarships -

START OF THE PROJECT

2009

INFORMATION

F Mugele

053 489 2106

f.mugele@utwente.nl

www.utwente.nl/tnw/pcf

PROJECT AIM

The goal of the project was to provide fundamental understanding of the impact dynamics and spreading of drops of complex fluids onto solid surfaces. Specific points of interest include the effect of ambient air on the impact process as well as the effect of surface topography.

PROGRESS

We applied our recently developed method of dual wavelength interferometry to understand the complex effect of ambient air on the impact of drops onto solid surfaces. The experiments yielded a detailed description of the effect of topographic pillars, ridges, and edges of variable geometric dimension on the formation of solid-liquid contact formation. The shape of a lubricating air film could be described with a thickness resolution of 10nm, lateral resolution of 3 μ m, and time resolution of 50 μ s. A PhD thesis was prepared and submitted to be defended in March 2014.

DISSERTATIONS

-

SCIENTIFIC PUBLICATIONS

1. Ruiter, J. de, Oh, J.M., Ende, D. van den & Mugele, F. (2013, juni 19). Air film collapse in droplet impact on (microstructured) surfaces. Marseille, France, First Int. Workshop on Wetting and Evaporation: Droplets of Pure and Complex Fluids.
2. Ruiter, R. de, Ruiter, J. de, Eral, H.B., Oh, J.M., Gorcum, M. van, Duits, M.H.G., Semperebon, C., Brinkmann, M. & Mugele, F. (2013). Electrowetting driven morphology transitions. Physics@FOM, Veldhoven: (2013, januari 22 - 2013, januari 23).

SHEAR INDUCED DIFFUSION OF BROWNIAN SUSPENSION

PROJECT AIM

Brownian particles in suspensions, diffuse due to the thermal fluctuation of the solvent molecules at equilibrium. If the suspension is driven out of equilibrium, diffusivity of the particle changes. Presence of shear enhances the diffusivity and it has been studied rigorously for non-Brownian particles. But, shear effect on Brownian suspension is less explored. Main focus is to study the effect of shear on Brownian diffusion and also to inspect the transition from Brownian diffusion to shear induced diffusion.

PROGRESS

Instead of conventional Rheometer, microchannels are used to perform the experiments. Different volume fraction of Brownian suspensions are injected through the microchannels at different pressure drops to reach various shear rates. Using particle tracking method, the velocity, shear and the diffusion data are extracted quite accurately. The diffusivity data are merging well for all the flow rates. It has been seen that the diffusion has a dependency on a non-dimensional parameter Péclet number which is a measure of applied shear and all the data are falling to a master curve. The transition from Brownian diffusion to shear induced diffusion is observed which is also matching well with literature.

DISSERTATIONS

-

SCIENTIFIC PUBLICATIONS

-

PROJECT LEADERS

F Mugele, MHG Duits

RESEARCH THEME

Complex dynamics of fluids

PARTICIPANTS

S Ghosh, MHG Duits

COOPERATIONS

-

FUNDED

| | |
|--------------|-------|
| NWO | |
| University | - |
| FOM | - |
| STW | - |
| NWO Other | 100 % |
| Industry | - |
| TNO | - |
| GTI | - |
| EU | - |
| Scholarships | - |

START OF THE PROJECT

2011

INFORMATION

MHG Duits
053 489 3097
m.h.g.duits@utwente.nl
www.utwente.nl/tnw/pcf/people/scientific_staff/MichelDuits

CELL-SPREAD

PROJECT LEADERS

LWMM Terstappen, F Mugele,
MHG Duits

RESEARCH THEME

Complex dynamics of fluids

PARTICIPANTS

AM Pit, I Stojanović

COOPERATIONS

-

FUNDED

STW, Micronit, IBIS, Ssens, Sanquin,
Merus

University -

FOM -

STW 83 %

NWO Other -

Industry 17 %

TNO -

GTI -

EU -

Scholarships -

START OF THE PROJECT

2011

INFORMATION

AM Pit

053 489 3093

a.m.pit@utwente.nl

PROJECT AIM

To detect the presence and affinity of therapeutic targets on circulating tumor cells (CTC). Digital microfluidics is used to create drops containing 1 CTC and guide the drop over a gold substrate patched with specific ligands targeting specific molecules. Using surface plasmon resonance imaging (SPRI) the binding processes of cell excreted proteins are quantified, effectively characterizing the cancer cell. This will allow for a quick diagnostic tool to administer the right type of medicine.

PROGRESS

The theoretical physics behind electrostatic potential wells is explained, and electrostatic forces exerted on a drop can be predicted. In drop trapping, the dominant forces are the oil's drag force opposed by the electrostatic force.

In practical experiments, different electrode structures below a microchannel are used to manipulate water drops in oil flow. A Y-shaped electrode structure has been used to sort drops at high speeds in one channel or the other. A branching structure is capable of guiding the sorted drop towards a point of interest on the microchip. Arrays of drops are held in position by another electrode structure, which will allow to determine the molecular contents of multiple drops simultaneously by SPRI. Using electrostatic potential wells we can controllably trap, guide, sort, coalesce, or split drops.

DISSERTATIONS

-

SCIENTIFIC PUBLICATIONS

-

ELECTRICALLY DRIVEN OPTOFLUIDIC LENSES

PROJECT AIM

The aim of the project is to demonstrate the functionality of liquid-liquid interface as a tunable adaptive fluidic lens, modulated electrostatically and regulated hydrostatically by applying electric field to a drop entrapped in an aperture. The objective is to suppress spherical aberration by simultaneously applying the electric field and regulating the backpressure. Further analysis includes optical characterization and demonstration of aberration controlling ability of lens by optical imaging, corroborated with optical simulations on Zemax.

PROGRESS

1. We fabricated the robust aspherical lens device and formulated the requisite protocol. Experiments are conducted in insulating silicone oil ambience with conducting aqueous salt solution as the drop phase. Performed experiments demonstrate that spherical aberration can be controlled and eventually eliminated by combination of laplace pressure and electrostatic force. Focal lengths are determined from the captured meniscus profiles. Tunability and reversibility is shown by overlapping of focal lengths after umpteenth cycles. Finally, we successfully establish the concept by optically imaging a square grid.

2. Incipient optical simulations are performed on the Zemax. We had build the set-up on Zemax in order to simulate our experimental observations..

DISSERTATIONS

-

SCIENTIFIC PUBLICATIONS

-

PROJECT LEADERS

F Mugele

RESEARCH THEME

Complex dynamics of fluids

PARTICIPANTS

K Mishra, HTM van den Ende,

F Mugele

COOPERATIONS

BP

FUNDED

STW

University -

FOM -

STW 50 %

NWO Other -

Industry 50 %

TNO -

GTI -

EU -

Scholarships -

START OF THE PROJECT

2011

INFORMATION

K Mishra

053 489 3134

k.mishra@utwente.nl

www.utwente.nl/tnw/pcf

PROJECT LEADERS

F Mugele, M Duits

RESEARCH THEME

Complex dynamics of fluids

PARTICIPANTS

R de Ruiter

COOPERATIONS

BP

FUNDED

BP

| | |
|--------------|-------|
| University | - |
| FOM | - |
| STW | - |
| NWO Other | - |
| Industry | 100 % |
| TNO | - |
| GTI | - |
| EU | - |
| Scholarships | - |

START OF THE PROJECT

2009

INFORMATION

F Mugele

053 489 2106

f.mugele@utwente.nl

www.utwente.nl/tnw/pcf

PROJECT AIM

The goal of the project is to understand the influence of wettability on the efficiency of enhanced oil recovery processes, in particular low salinity water flooding. The project focuses on the consequence of altered wettability on the behavior of drops in microfluidic two-phase flows as they occur in oil reservoirs. Next to chemically induced changes of surface wettability, we make use of electrowetting as a tool to illustrate basic concepts of wetting and morphology transitions in confined systems.

PROGRESS

In 2013, we developed an electrowetting-based platform for the investigation of trapping and release mechanisms of drops in microfluidic two-phase flow systems with heterogeneous channel walls. We investigated the relative strength of viscous drag forces and viscosity-induced pressure gradients on the trapping of drops by channel heterogeneities. Moreover, we found that even small amounts of contact angle hysteresis can have a profound on the stability of wetting morphologies in complex geometries, such as model pore throats. On an applied note, our experiments demonstrated the benefits of hybrid electrowetting-two phase flow microfluidic systems for Lab-on-a-Chip systems. Our paper was featured on the cover page of the journal Lab-on-a-Chip in January 2014.

DISSERTATIONS

-

SCIENTIFIC PUBLICATIONS

-



Prof.dr.ir. RGH Lammertink

Research within the Soft matter, Fluidics and Interfaces group is directed at interfacial phenomena and processes that are relevant for mass and heat transport. We wish to study and exploit fundamental principles where fluid flow encounters structures on a sub-millimeter length scale. Current topics of interest are:

ADVANCED MICROREACTORS

The fabrication and operation of dedicated microreactors, amendable to scaling are investigated. Multiphase reactor systems that incorporate membrane functionality to stabilize interfaces and perform separations are developed.

SOFT INTERFACES

Liquid-liquid and gas-liquid interfaces are crucial in many chemical processes. Interfacial phenomena, including wetting behavior, interfacial tension (gradients), interfacial curvature, are studied to gain understanding in related transport processes near these interfaces.

MICRO- AND NANOFLUIDICS

This topic addresses liquid flow in confined geometries. Its relation to mass and energy transport are studied in both experimental and numerical ways. Special attention is given to boundary layer and concentration polarization phenomena.

PROJECT AIM

The focus of this project lies on interfacial transport phenomena that occur in e.g. membrane processes, and in particular on those phenomena that often form a limiting factor in these processes such as concentration polarization. By investigation of these phenomena in well-defined systems, in microfluidic devices for example, we aim to acquire a deeper and more fundamental understanding of interfacial transport phenomena.

PROGRESS

In 2013, a numerical study on the relation between the interface of the bubble mattress and interfacial transport has been finished and published. We demonstrated that it is possible to enhance momentum and mass transport simultaneously. However, when the bubble decrease in size this effect disappears. To investigate the influence of partial wall slip on mass/heat transport at a more general level, we started a numerical study on the Graetz-Nusselt problem extended to both homogeneous and heterogeneous slip. This study is advancing, and we hope to finish it this year. After having performed these numerical studies, the focus will be on experimental work.

DISSERTATIONS

-

SCIENTIFIC PUBLICATIONS

1. Karatay, E. and Haase, A.S. and Visser, C.W. and Sun, C. and Lohse, D. and Tsai, P.A. and Lammertink, R.G.H. (2013) Control of slippage with tunable bubble mattresses. Proceedings of the National Academy of Sciences of the United States of America, 110 . 8422 - 8426.
2. Haase, A. Sander and Karatay, Elif and Tsai, Peichun Amy and Lammertink, Rob G.H. (2013) Momentum and mass transport over a bubble mattress: the influence of interface geometry. Soft Matter, 9 . 8949 - 8957.

PROJECT LEADERS

RGH Lammertink

RESEARCH THEME

Complex dynamics of fluids

PARTICIPANTS

S Haase

COOPERATIONS

-

FUNDED

| | |
|--------------|-------|
| ERC | |
| University | - |
| FOM | - |
| STW | - |
| NWO Other | - |
| Industry | - |
| TNO | - |
| GTI | - |
| EU | 100 % |
| Scholarships | - |

START OF THE PROJECT

2012

INFORMATION

RGH Lammertink

053 489 2063

r.g.h.lammertink@utwente.nl

www.utwente.nl/tnw/sfi/people/staff/lammertink

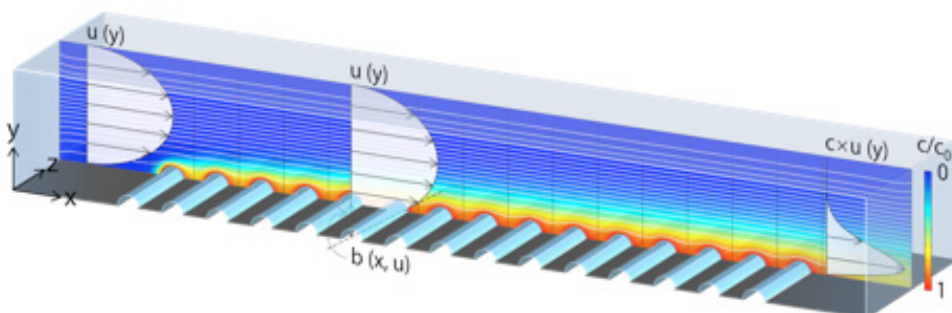

Illustration of liquid flow along a series of immobilized gas bubbles.

MEANDER REACTOR

PROJECT LEADERS

RGH Lammertink

RESEARCH THEME

Complex dynamics of fluids

PARTICIPANTS

Elif Karatay

COOPERATIONS

-

FUNDED

NWO / Poac

University -

FOM -

STW -

NWO Other 100 %

Industry -

TNO -

GTI -

EU -

Scholarships -

START OF THE PROJECT

2009

INFORMATION

RGH Lammertink

053 489 2063

r.g.h.lammertink@utwente.nl

www.utwente.nl/tnw/sfi/people/staff/

lammertink

PROJECT AIM

The goal of this project is to demonstrate an approach re-shaping the scene: perform chemical conversions that are not reasonable without the use of multifunctional micro reactors. In this concept, G/L contacting and electrokinetic separations will be developed on chip.

PROGRESS

Experimental observation of flow past immobilized bubbles was obtained. These experiments are relevant in understanding the gas-liquid contacting using porous membranes as interface stabilizers. The fluid dynamics, expressed via the slip and friction, were investigated for varying bubble geometries. In situ measurements of gas absorption into the along flowing liquid were carried out. It was demonstrated that the short contact times of liquid with individual bubbles result in non-equilibrium interface conditions. A statistical rate theory for gas absorption was compared to the equilibrium Henry's condition and was found to better match the experimental observations.

DISSERTATIONS

1. Karatay, Elif : Microfluidic studies of interfacial transport. (Sept. 2013).

SCIENTIFIC PUBLICATIONS

1. Karatay, E. and Haase, A.S. and Visser, C.W. and Sun, C. and Lohse, D. and Tsai, P.A. and Lammertink, R.G.H. (2013) Control of slippage with tunable bubble mattresses. Proceedings of the National Academy of Sciences of the United States of America, 110, 8422 - 8426.
2. Karatay, E., Tsai, P. A., & Lammertink, R. G. H. (2013). Rate of gas absorption on a slippery bubble mattress. Soft Matter, 9(46), 11098.
3. Haase, A. S., Karatay, E., Tsai, P. A., & Lammertink, R. G. H. (2013). Momentum and mass transport over a bubble mattress: The influence of interface geometry. Soft Matter, 9(37), 8949–8957.

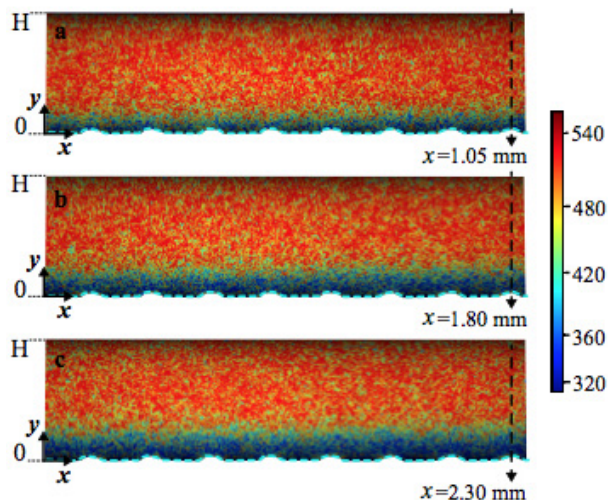

In situ oxygen concentration measurements using fluorescence lifetime imaging (taken from Karatay, E., Tsai, P. A., & Lammertink, R. G. H. (2013). Rate of gas absorption on a slippery bubble mattress. Soft Matter, 9(46), 11098.)

TRANSPORT AT THE MICROSCOPIC INTERFACE

PROJECT AIM

The proposed experiments include the measurement of fluid flow and ion concentration, both at high precision near the membrane. In electro dialysis, an ion selective membrane is used through which ion transport is driven by an external electric field. Under severe concentration polarization conditions, the occurrence of electroconvection phenomena is typically observed. The origin of this regime is today still a topic of discussion. We intend to approach this problem by using controlled microfluidic experiments near ion selective channels.

PROGRESS

An experimental set-up for voltage-current characterization measurements is established and preliminary measurements are conducted. A time-dependence of ion transport through the ion selective interface is observed, which will be investigated in more detail. Preparations for visualization by means of fluorescent dyes and PIV measurements are taken. Design of microchips/experimental geometry for investigation of several effects (e.g. Debye Length, confinement, hydrodynamics).

DISSERTATIONS

-

SCIENTIFIC PUBLICATIONS

-

PROJECT LEADERS

RGH Lammertink

RESEARCH THEME

Complex dynamics of fluids

PARTICIPANTS

A Benneker

COOPERATIONS

-

FUNDED

ERC

University -

FOM -

STW -

NWO Other -

Industry -

TNO -

GTI -

EU 100 %

Scholarships -

START OF THE PROJECT

2013

INFORMATION

RGH Lammertink

053 489 2063

r.g.h.lammertink@utwente.nl

www.utwente.nl/tnw/sfi/people/staff/

lammertink

Micro- and nanofluidic devices to study the ion and momentum transport.

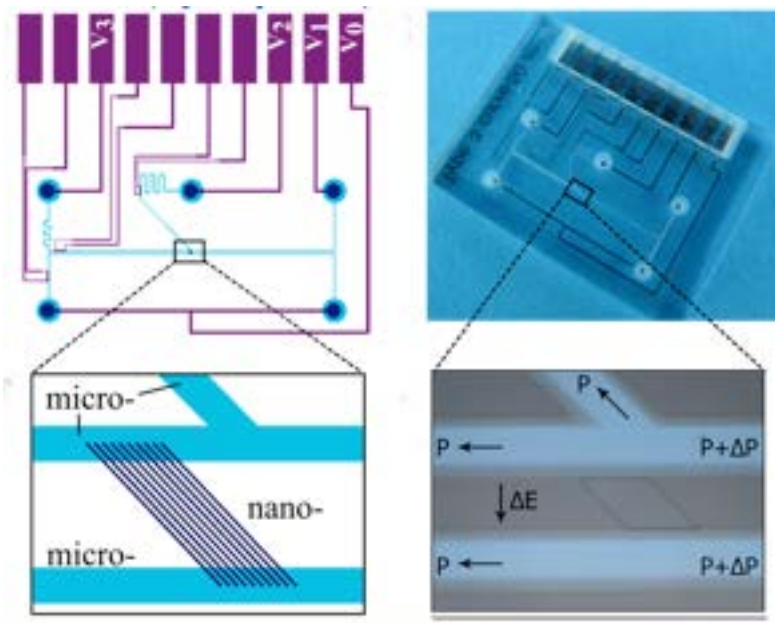

PROJECT LEADERS

RGH Lammertink

RESEARCH THEME

Complex dynamics of fluids

PARTICIPANTS

El Tayeb el Obied, Khalid

COOPERATIONS

-

FUNDED

ERC

University -

FOM -

STW -

NWO Other -

Industry -

TNO -

GTI -

EU 100 %

Scholarships -

START OF THE PROJECT

2013

INFORMATION

RGH Lammertink

053 489 2063

r.g.h.lammertink@utwente.nl

www.utwente.nl/tnw/sfi/people/staff/

lammertink

PROJECT AIM

The growth of bacteria in water treatment membrane units is considered as one of the most prominent challenges this technology faces. Although biofouling is the most severe form of fouling for membrane based water purification processes, no generally accepted mechanism is present. There has been significant effort in elucidating the formation and growth of biofilms inside membrane purification units. In recent microfluidic experiments, it was hypothesized that the biofilm growth is associated with subtle secondary flow patterns that exist in square shaped channels. Furthermore, extensive fluid dynamics simulations (FDI) indicated that the local substrate and oxygen concentrations in biofilm covered flow channels govern the biofilm growth. Here, we seek to perform experimental investigations on the microscopic scale concerning convection and concentration profiling.

PROGRESS

In the past year a literature study has been done. In order to study the mentioned biofouling process, a microfluidic platform will be used. This will give the ability to obtain information regarding the fluid flow and nutrient concentration. The information regarding the fluid profiles will be obtained via microPIV (Particle Imaging Velocimetry) measurements, while concentration gradients will be obtained from fluorescence microscopy. At the current stage the microfluidic devices are being developed.

DISSERTATIONS

-

SCIENTIFIC PUBLICATIONS

-

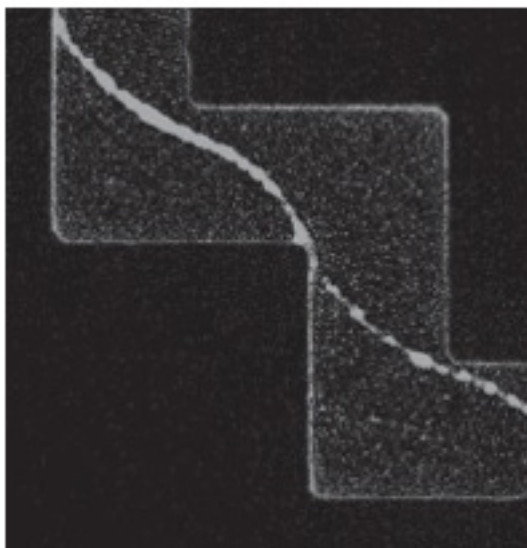

Biofilm development in a micro-channel (from Rusconi, R., et al. (2010). "Laminar flow around corners triggers the formation of biofilm streamers." *Journal of the Royal Society Interface* 7(50): 1293-1299)



Prof.dr.ir. EWC van Groesen

In our group AAMP we study natural phenomena or help to design and improve technical apparatus or processes. We investigate the propagation of surface waves on a layer of fluid, the shock propagation caused by volcano eruptions through the earth, and the way how light gets reflected and transmitted through different materials.

We study these aspects with a set of suitable mathematical techniques that we extend and improve constantly. Our understanding of the phenomena is reflected in the mathematical models, which are updated and improved with increased understanding from theoretical investigations and simulations. Except for their mathematical structure with intrinsic beauty, our investigations are often 'useful': for hydrodynamic laboratories we advise how to generate the wave fields that they want to produce in their tanks to test ships in realistic situations, the calculations of seismic events may lead to an understanding which earth quakes give rise to large tsunamis, the design of optical devices with nano-scale structures helps to advance telecommunication, etc.

The topics mentioned above are very diverse in their appearance, and cover length scales ranging from 10^{-9} till 10^7 meter. The beauty of the mathematical descriptions is that they are actually quite similar: the major physical process is the evolution of waves, or an abstraction of it. Special properties that depend on the application are reflected in the mathematical structure of the wave equations that are at the basis of the models. For instance, energy or momentum conservation corresponds to symmetries in the mathematical formulations. Specific methods that we use include variational methods, which exploit the remarkable fact that often a certain optimality property can be found in the phenomenon. Except for theoretical methods, often supported with computer algebraic calculations, regularly we design larger or smaller simulation tools of a numerical nature.

For the design of these numerical schemes we aim to keep the special properties of our theoretical models as well, leading to consistent finite dimensional version of the infinite dimensional models.

The research in water waves contains various topics. Characteristic is that for irrotational flows we approach the problems in a unified consistent modelling way. This is based on the fact that upon neglecting dissipation, the full free surface equations have a basic variational structure (Luke, 1967), with the free surface equations described by a Hamiltonian system (Zakharov 1968, Broer 1974). In our modelling of specific wave fields, we exploit this structure by finding approximations of the kinetic energy part of the Hamiltonian. This is used for approximate models described by pde's like the shallow water equations, Boussinesq-, KdV and NLS-type of equations.

For numerical simulations, this structure is exploited to find consistent discretizations by variational restriction: the functionals defined on infinite dimensional spaces are restricted to finite dimensional subspaces, which may be high dimensional but may also be much more restricted by including essential properties of the phenomenon in the description, depending on the specific cases.

Within the basic approach, we include various active or passive boundary conditions, depending on the application (to generate waves by wave flaps for hydrodynamic laboratories, or bottom motions for seismic applications), or to allow a reflection-free description for calculations on numerical artificial windows. Locally, the activities are grouped in the projects Math Modelling and consistent Numerical Simulations, Free flows and Extreme Waves, Coastal Waves, and Seismic generation of waves.

WAVE MODELLING AND SIMULATION FOR OCEAN AND COASTAL ENGINEERING

PROJECT AIM

In various subprojects the variational structure of inviscid fluid dynamics is used to derive accurate and efficient numerical implementations of Boussinesq-type of equations. Hamiltonian variational wave models with exact dispersion are obtained with a spatial-spectral implementation, and with a problem-dependent optimal dispersive FEM implementation. Applications deal with laboratory, coastal and oceanic waves, including harbour waves, extreme (freak) waves, and tsunamis.

PROGRESS

Supported by comparison with experiments, we improved the FE-Variational Boussinesq Model for harbour simulations with short crested wave influx and partially reflecting walls. For the spatial-spectral AB model we simulate (partially) reflecting walls and moving shore lines for run-up with embedded methods; wave breaking based on a kinematic breaking criterion showed good performance for breaking in deep water and over bathymetry. Run-up was also modelled using a mixed numerical-analytic method through an effective boundary condition. Effects of a tsunami caused by a possible Krakatau explosion on a planned sea-dike in the Jakarta harbour were calculated. Phase accurate predictions of sea states from radar images of (multi-modal) seas were shown to be possible up to the physical limit using a dynamic averaging method.

DISSERTATIONS

1. Lie She Liam, Mathematical modelling of generation and forward propagation of dispersive waves 15 May 2013.

SCIENTIFIC PUBLICATIONS

-

PROJECT LEADERS

EWC van Groesen

RESEARCH THEME

Mathematical and computational methods for fluid flow analysis

PARTICIPANTS

R. Kurnia (PhD-UT), Lie She Liam (PhD-UT/LMI), M. Hafizh (UT/LMI) D. Adytia (PD-UT/LMI); W. Kristina (PhD UT), A. P. Wijaya (PhD-UT/LMI), Dr. Andonowati (LabMath-Indonesia & ITB)

COOPERATIONS

LabMath-Indonesia, Bandung Indonesia, MARIN Wageningen, TUD Ship hydromechanics & structures

FUNDED

| | |
|-----------------------|------|
| UT, STW, NWO-ALW, IOP | |
| University | 30 % |
| FOM | - |
| STW | 30 % |
| NWO Other | 10 % |
| Industry | 10 % |
| TNO | - |
| GTI | 10 % |
| EU | - |
| Scholarships | 10 % |

START OF THE PROJECT

2012

INFORMATION

E van Groesen
053 489 3413
e.w.c.vangroesen@utwente.nl



Prof.dr.ir. JWW van der Vegt

The research in the Mathematics of Computational Science group in the Department of Applied Mathematics of the University of Twente concentrates on two main topics:

- ♦ The development, analysis and application of numerical algorithms for the (adaptive) solution of partial differential equations for problems originating from the physical and technical sciences, in particular (discontinuous Galerkin) finite element methods.
- ♦ Mathematical modeling of complex physical problems to make them accessible for computation, in particular for turbulence and geophysical problems. In order to support these activities a significant research effort is directed towards the development of hpGEM, an object oriented toolkit for finite element methods, written in C++, and suitable for high performance parallel computers. Important applications are in the fields of gas dynamics, wet chemical etching of microstructures, fluid structure interaction, two phase flows both dispersed and with free surfaces, water waves, large eddy simulation of turbulent flows, geophysical flows and computational electromagnetics. Many of these projects are conducted in close collaboration with groups in physics and chemical technology, large technological research institutes (NLR, MARIN, WL Delft Hydraulics, KNMI), and industry (DSM, AKZO and Shell).

The research is conducted in the research institute IMPACT and the research in two-phase flows is part of the UT spearhead program "Dispersed multiphase flows". The NACM group participates in the 3TU Center of Excellence for Multiscale Phenomena.

COMPLEX WAVE-CURRENT INTERACTIONS IN A NUMERICAL WAVE TANK

PROJECT AIM

Our aim is to develop novel space-time (dis)continuous Galerkin methods based on variational principles to model nonlinear free-surface waves. The advantage is that the resulting numerical discretization will preserve energy, phase-space structure and variational structure. Further, the numerical scheme will show no decay in amplitude and will be suitable for long time simulations. Numerical results will be compared with laboratory datasets from: 3D inertial waves generated by The Royal Netherlands Institute of Sea Research (NIOZ), wave tank data of the Maritime Research Institute Netherlands (MARIN).

PROGRESS

A novel discontinuous in time Galerkin finite element method was developed, which allowed us to derive a set of known and new symplectic schemes. An extended analysis for this new class of schemes was developed. This approach allowed the design of a variational finite element method for nonlinear free surface waves based on Luke's variational principle. The method results in a space-time discretization. The resulting numerical scheme conserves discrete energy and shows no amplitude decay. The method is accommodated with the wave maker movement and extensively validated against experimental data. These results show that the newly developed numerical discretization is very accurate and stable for strongly non-linear potential flow water waves. Besides a new variational approach to derive jump conditions for flows with discontinuities is developed. For internal waves a novel Hamiltonian discontinuous Galerkin discretization was developed, which also includes vorticity in the fluid. This method was extensively tested and also verified with novel analytical solutions.

DISSERTATIONS

1. Dr. S. Nurijanyan, Discrete and continuous Hamiltonian systems for wave modelling. Thesis defence 9-10-2013, Promotors Prof.dr.ir J.J.W. van der Vegt, and Prof.dr.ir. O. Bokhove.

SCIENTIFIC PUBLICATIONS

1. E. Gagarina, J.J.W. van der Vegt and O. Bokhove, 2013, "Horizontal Circulation and Jumps in Hamiltonian Water Wave Model", *Nonlin. Processes Geophys.*, 20(4), 483-500, doi:10.5194/npg-20-483-2013, 2013.
2. S. Nurijanyan, J.J.W. van der Vegt and O. Bokhove, Hamiltonian discontinuous Galerkin FEM for linear, rotating incompressible Euler equations: inertial waves, *JCP*, Vol. 241, pp. 502-525, 2013.
3. S. Nurijanyan, O. Bokhove, and L.R.M. Maas, L.R.M. A new semi-analytical solution for inertial waves in a rectangular parallelepiped. *Physics of fluids*, 25(12). 126601, (2013).
4. Peeters, B.W.I. and Oliver, M. and Bokhove, O. and Molchanov, V. (2013) On the rate of convergence of the Hamiltonian particle-mesh method. In: *Meshfree Methods for Partial Differential Equations VI. Lecture Notes in Computational Science and Engineering* 89. Springer Verlag, Berlin, pp. 25-43.

PROJECT LEADERS

O Bokhove, JJW van der Vegt

RESEARCH THEME

Mathematical and computational methods for fluid flow analysis

PARTICIPANTS

S Nurijanyan, E Gagarina, VR Ambati

COOPERATIONS

A Thornton

FUNDED

| | |
|--------------|-------|
| STW/NWO | |
| University | - |
| FOM | - |
| STW | 100 % |
| NWO Other | - |
| Industry | - |
| TNO | - |
| GTI | - |
| EU | - |
| Scholarships | - |

START OF THE PROJECT

2008

INFORMATION

o.bokhove@math.utwente.nl
www.math.utwente.nl/~bokhove/

j.j.w.vandervegt@utwente.nl
<http://wwwhome.math.utwente.nl/~vegtjjw/>

e.gagarina@math.utwente.nl
www.math.utwente.nl/~gagarinae

DISCONTINUOUS GALERKIN METHOD FOR INKJET FLOW SIMULATIONS

PROJECT LEADERS

JJW van der Vegt

RESEARCH THEME

Mathematical and computational methods for fluid flow analysis

PARTICIPANTS

T Medvedeva

COOPERATIONS

Océ Technologies

FUNDED

HIPRINS

University -

FOM -

STW -

NWO Other -

Industry -

TNO -

GTI -

EU 100 %

Scholarships -

START OF THE PROJECT

2011

INFORMATION

JJW van der Vegt

053 489 5628

j.j.w.vandervegt@math.utwente.nl

www.home.math.utwente.nl/~vegtjjw/

PROJECT AIM

Inkjet flow simulations require the accurate computation of the free surface at the liquid-air interface, and in particular the break-up into small droplets and the effect of air on the droplet motion. In order to achieve these goals a new discontinuous Galerkin finite element discretization will be developed which can accurately compute the droplet formation and droplet motion. The use of a discontinuous Galerkin method in this project is motivated by the possibility to obtain higher order accurate numerical discretizations on solution adaptive locally refined meshes, which opens new ways to accurately simulate inkjet flows.

PROGRESS

Recently, a new higher-order accurate local discontinuous Galerkin finite element method was developed for the one-dimensional lubrication model derived by Eggers and Dupont. Additional stabilization was added into formulation to prevent high frequency oscillations. Singly diagonally implicit Runge-Kutta time integration method in combination with Newton method have been implemented to provide a stable and accurate time integration scheme. This model is currently extensively tested on a number of inkjet problems, including breakup into droplets.

DISSERTATIONS

-

SCIENTIFIC PUBLICATIONS

-

LOCAL DISCONTINUOUS GALERKIN METHOD FOR PHASE TRANSITION

PROJECT AIM

The numerical simulation of phase transition requires an accurate description of the physical phenomenon at the interface between different phases. However, the equations modeling phase transitions are hyperbolic-elliptic systems for which standard numerical methods are not suitable. In this project, local discontinuous Galerkin (LDG) method, enjoying conservative, stable and highly accurate properties, is considered to applied to solve the system of phase transitions. Due to its local element wise discretization, LDG method is well suited for local refinement, which is good to capture the phase.

PROGRESS

A paper about solving a hyperbolic-elliptic system modeling phase transition in solid and fluids by a local discontinuous Galerkin method was prepared and accepted. Stable numerical solutions without artifacts were obtained. Also, we proved stability and an error estimate for the numerical solutions obtained with the LDG method. Currently, we extend the LDG method to the Navier-Stokes-Korteweg (NSK) equations modeling of phase transition between a vapor and liquid. This system is quite complex. The LDG method for the NSK system is implemented for 1D and 2D problems. In order to improve computational efficiency, we use mesh adaption and a diagonally implicit Runge-Kutta time method. Local refinement in 1D works satisfactory, currently we study mesh adaption for two-dimensional problems. In a related project we also considered space-time discontinuous Galerkin method for the incompressible Navier-Stokes equations.

DISSERTATIONS

-

SCIENTIFIC PUBLICATIONS

1. S. Rhebergen, B. Cockburn, and J.J.W. van der Vegt, A space-time discontinuous Galerkin method for the incompressible Navier-Stokes equations. *Journal of Computational Physics*, 233, pp. 339-358 (2013).

PROJECT LEADERS

JJW van der Vegt

RESEARCH THEME

Mathematical and computational methods for fluid flow analysis

PARTICIPANTS

L Tian, Prof. Yan Xu (USTC, China)
Prof.dr. JGM Kuerten

COOPERATIONS

University of Science and Technology of China (USTC), Hefei, China

FUNDED

CSC Fellowship China
University -
FOM -
STW -
NWO Other -
Industry -
TNO -
GTI -
EU -
Scholarships 100 %

START OF THE PROJECT

2011

INFORMATION

L Tian
L.Tian@utwente.nl

PROJECT LEADERS

O Bokhove, S Luding
A R Thornton and JJW van der Vegt

RESEARCH THEME

Mathematical and computational
methods for fluid flow analysis

PARTICIPANTS

DR Tunuguntla

COOPERATIONS

T Weinhart

FUNDED

| | |
|--------------|-------|
| STW | |
| University | - |
| FOM | - |
| STW | 100 % |
| NWO Other | - |
| Industry | - |
| TNO | - |
| GTI | - |
| EU | - |
| Scholarships | - |

START OF THE PROJECT

2011

INFORMATION

D Tunuguntla
053 489 3373
D.R.Tunuguntla@utwente.nl

PROJECT AIM

The primary goal of the project is to investigate dry polydispersed, both in size and density, granular flows over inclined channels including segregation phenomena. For this purpose, we develop a macro-scale continuum Discontinuous Galerkin Finite Element Method (DGFEM) granular flow model and couple it to a micro-scale discrete particle model (DPM). This project also runs in close collaboration with an industrial partner, Tata Steel.

PROGRESS

(i) We proposed an extension to mixture theory based continuum models that allows their application to bi-disperse flows, over inclined channels, with particles varying in density and size. Our model incorporates both: a recently proposed explicit formula concerning how the total pressure is distributed among different species of particles, which is one of the key elements of mixture theory based kinetic sieving models, and a shear rate dependent drag. The resulting model is used to predict the range of sizes and densities for which the mixture segregates. The model also predicts very weak segregation, which is benchmarked using discrete element simulations (DEMs). (ii) Furthermore, a highly effective tool called coarse-graining is developed to extract the macroscopic field variables, appearing in continuum-mechanical models for bi-disperse mixture flows. By this micro-macro mapping, one could use DPMs to calibrate the developed continuum models.

DISSERTATIONS

-

SCIENTIFIC PUBLICATIONS

1. Thornton, A.R.; Krijgsman, D.; Fransen, R.; Gonzalez, S.; Tunuguntla, D.R.; ten Voortwis, A.; Luding, S.; Bokhove, O.; Weinhart, T. Mercury-DPM: Fast particle simulations in complex geometries, EnginSoft Year 10, No. 1 (2013).
2. Weinhart, T., Luding, S., Thornton, A.R., From discrete particles to continuum fields in mixtures, AIP Conf. Proc. 1542, 1202-1205 (2013).
3. Thornton, A.R.; Weinhart, T.; Ogarko, V. and Luding, S. Multi-scale modeling of multi-component granular materials. Journal Computer Methods in Materials Science (2013). 13:2 p1-16.

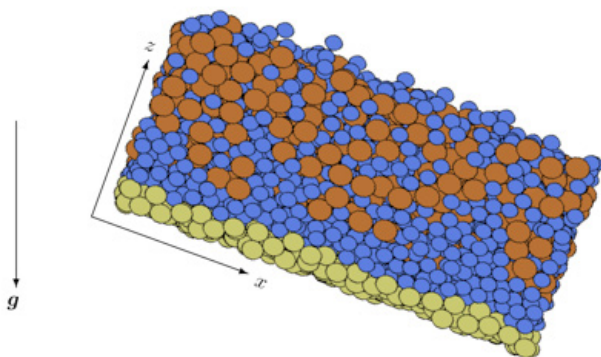

Bi-disperse mixture flows flowing over a rough inclined channel

MULTISCALE MODELING & SIMULATION



Prof.dr.ir. BJ Geurts



Prof.dr. HJH Clercx



Prof.dr. JGM Kuerten

I am a scientist, trained as theoretical physicist and applied mathematician, holding the chair for Multiscale Modeling and Simulation at the University of Twente and for Anisotropic Turbulence at Eindhoven University of Technology. My research focus is on mathematics, physics and numerics of multiscale problems in turbulence, mixing, complex fluids and biology. I try to find simplicity behind complexity, find structures and what combines, rather than what separates. I contribute to 3TU.AMI, ERCOFTAC, TGS Computational Science and act as HoD of Applied Mathematics in Twente.

PROJECT AIM

Develop an accurate method with which evaporation and condensation of water in air can be simulated for dispersed droplet-laden turbulent flow in a channel. Understand turbulence-phase transition interactions.

PROGRESS

A simulation study was performed comparing incompressible with low-Mach compressible formulations for the case of turbulent channel flow. The dependence on Mach number was investigated along with the dependence on the higher temperature level in the channel, larger heat flux through the walls and initial value of relative humidity. A specialized semi-explicit low Mach number time-integration algorithm was developed for the considered problem which permits to avoid a severe restriction on the time step in the fully explicit solver. The results obtained with the new solver were verified using the results from the explicit compressible solver.

DISSERTATIONS

-

SCIENTIFIC PUBLICATIONS

1. Bukhvosova, A. and Russo, E. and Kuerten, J.G.M. and Geurts, B.J. Comparison of DNS of compressible and incompressible turbulent droplet-laden heated channel flow with phase transition In: Proceedings of DLES9, Dresden, April 2013.
2. Bukhvosova, A. and Kuerten, J.G.M. and Geurts, B.J. Low-Mach algorithm for heated droplet-laden turbulent channel flow including phase transition. In Proceedings of 11th ICNAAM, Rhodes, September 2013.

PROJECT LEADERS

BJ Geurts

RESEARCH THEME

Mathematical and computational methods for fluid flow analysis

PARTICIPANTS

A Bukhvosova, H Kuerten

COOPERATIONS

-

FUNDED

| | |
|--------------|-------|
| FOM | |
| University | - |
| FOM | - |
| STW | - |
| NWO Other | - |
| Industry | 100 % |
| TNO | - |
| GTI | - |
| EU | - |
| Scholarships | - |

START OF THE PROJECT

2011

INFORMATION

A Bukhvosova

053 489 3384

a.bukhvosova@utwente.nl

SIMULATION OF VISCOUS FLOW IN A HETEROGENEOUS POROUS MEDIUM

PROJECT LEADERS

BJ Geurts

RESEARCH THEME

Mathematical and computational methods for fluid flow analysis

PARTICIPANTS

M Stanic, A Kuczaj

COOPERATIONS

-

FUNDED

Philip Morris International S.A.

University -

FOM -

STW -

NWO Other -

Industry 100 %

TNO -

GTI -

EU -

Scholarships -

START OF THE PROJECT

2012

INFORMATION

M Stanic

053 489 3414

m.stanic@utwente.nl

PROJECT AIM

Develop an accurate method with which flow through complex porous domains can be predicted and incorporate non-equilibrium heat and mass transfer into the volume-averaged framework. Realize this in OpenFOAM.

PROGRESS

A first model using segregated solvers for incompressible flow was developed, displaying unphysical oscillations. Current work is directed toward extensions that remove these oscillations.

DISSERTATIONS

-

SCIENTIFIC PUBLICATIONS

-

SIMULATION OF MULTI-SPECIES AEROSOL

PROJECT AIM

Develop an accurate method with which nucleation, coalescence, break-up, evaporation and condensation of multi-species aerosol can be simulated, involving Euler-Euler, Euler-Lagrange multi-phase flow in complex porous media.

PROGRESS

A multi-species nucleation model was developed and implemented in OpenFOAM and solved using an extended PISO algorithm.

DISSERTATIONS

-

SCIENTIFIC PUBLICATIONS

-

PROJECT LEADERS

BJ Geurts

RESEARCH THEME

Mathematical and computational methods for fluid flow analysis

PARTICIPANTS

E Frederix, A Kuczaj

COOPERATIONS

-

FUNDED

Philip Morris International S.A.

University -

FOM -

STW -

NWO Other -

Industry 100 %

TNO -

GTI -

EU -

Scholarships -

START OF THE PROJECT

2012

INFORMATION

E Frederix

053 489 3414

e.m.a.frederix@utwente.nl

MATHEMATICAL ANALYSIS AND CLASSIFICATION OF FLOW TOPOLOGIES IN CEREBRAL ANEURYSMS

PROJECT LEADERS

BJ Geurts

RESEARCH THEME

Mathematical and computational methods for fluid flow analysis

PARTICIPANTS

J Mikhal

COOPERATIONS

Prof. Dr. Ir. C. H. Slump, SAS Group, EEMCS Department, University of Twente

FUNDED

| | |
|----------------------|-------|
| University of Twente | |
| University | 100 % |
| FOM | - |
| STW | - |
| NWO Other | - |
| Industry | - |
| TNO | - |
| GTI | - |
| EU | - |
| Scholarships | - |

START OF THE PROJECT

2008

INFORMATION

J Mikhal

053 489 3414

j.mikhal@ewi.utwente.nl

PROJECT AIM

Perform computational modeling, analysis and classification of flow topologies that occur in aneurysms in the human brain. Evaluation of the probability of rupture, and long-time stability are important factors.

PROGRESS

The developed simulation method was applied to realistic cerebral aneurysms. Steady and pulsatile flow conditions were investigated and transition to complex flow was observed with growing size of the aneurysm. A thesis was completed and defended successfully.

DISSERTATIONS

-

SCIENTIFIC PUBLICATIONS

1. J Mikhal, BJ Geurts. Immersed boundary method for pulsatile transitional flow in realistic cerebral aneurysms *Computers & Fluids* 91, 144-163.
2. J Mikhal, BJ Geurts. Development and application of a volume penalization immersed boundary method for the computation of blood flow and shear stresses in cerebral vessels and aneurysms. *Journal of mathematical biology* 67 (6-7), 1847-1875.

AEROSOL PARTICLE MOTION IN POROUS MEDIA

PROJECT AIM

The target of the project is to understand aerosol particle dynamics in porous media. This will be done by performing numerical simulations and analysis of aerosol property evolution in complex geometries due to evaporation, condensation and collision.

PROGRESS

A paper was written and accepted for publication, detailing the development of a no-slip consistent particle-tracking method for volume penalizing immersed boundary methods. A Brownian motion model was developed for tracking small aerosol droplets in porous media. A nucleation model was developed with which the evolution of virgin aerosol under supersaturated, strongly cooled flow conditions can be simulated.

DISSERTATIONS

-

SCIENTIFIC PUBLICATIONS

1. L. Ghazaryan, DJ Lopez Penha, S Stolz, AK Kuczaj, BJ Geurts: No slip consistent immersed boundary particle tracking to simulate impaction filtration in porous media. International Journal for Numerical Methods in Fluids 73 (7), 615-636.

PROJECT LEADERS

BJ Geurts

RESEARCH THEME

Mathematical and computational methods for fluid flow analysis

PARTICIPANTS

L Ghazaryan

COOPERATIONS

Philip Morris International – Dr.

Steffen Stolz

FUNDED

Philip Morris International S.A.

University -

FOM -

STW -

NWO Other -

Industry 100 %

TNO -

GTI -

EU -

Scholarships -

START OF THE PROJECT

2008

INFORMATION

L Ghazaryan

053 489 3414

l.ghazaryan@utwente.nl



Prof.dr.ir. HWM Hoeijmakers



Prof.dr.ir. A Hirschberg

Research within the group Engineering Fluid Dynamics deals with theoretical, numerical and experimental studies, aimed for applications in Mechanical Engineering. The research focuses on the following fields:

FLUID MECHANICS OF ROTATING FLOW MACHINERY

The flow in centrifugal pumps and around wind turbine blades is studied experimentally and numerically, with the objective of developing methods for predicting the performance of these machines. This relates to head, efficiency and cavitation characteristics for pumps and generated power for wind turbines. The methods are used as tools for improving the design of these rotating machines. Also methods for inverse design and optimisation are considered. A new rotating test-rig has been developed for experimental studies of the flow in impeller channels.

AERO-ACOUSTICS

For Computational Aeroacoustics Discontinuous Galerkin finite-element methods for unstructured grids are developed for computing sound propagation in fluids. The capabilities of these methods are analysed analytically. Within the field of Experimental Aeroacoustics the generation of sound by objects is studied. For this an aero-acoustic test facility has been developed that is based on a closed circuit wind tunnel. The (0.7x0.9 m²) free-jet test-section (maximum velocity 65 m/s) of the silent wind tunnel is enclosed by a 6x6x4m³ anechoic chamber.

MULTI-PHASE FLOWS AND FLOWS WITH PHASE TRANSITION

Models and unstructured-grid computational methods are developed for high-speed, swirling or non-swirling, condensing flows of mixtures of gases and liquids in complex geometries. Topics of interest are slipping droplets in turbulent flow and the prediction of the evolution of droplet radius distribution. Models and unstructured-grid computational methods are developed for liquid flows with unsteady sheet cavitation and vortex cavitation. Phase transition is a driving mechanism in the study of ice accretion on aircraft wings in flight. Separation of oil/water mixtures (bulk separation and water treatment) is considered within a centrifugal force field generated in swirling pipe flows. Finally dense-phase fluid-particulate flow is studied with application to dredging type of flows.

FLUID-STRUCTURE INTERACTION AND FLOW CONTROL

Research on fluid-structure interaction focuses on the flow-induced vibrations of compressor valves and on the unsteady motion of bluff bodies, in particular of gas bubbles and solid spheres induced by vortex shedding. Also investigated is flapping-wing lift/propulsion for robot-bird configurations. Flow control is developed for application to wind turbine blades and diffusers, employing synthetic jets and plasma actuators. Both numerical and experimental investigations are conducted.

THIN-FILM FLOWS

The flow in narrow domains between deforming surfaces under extreme conditions is studied theoretically as well as experimentally. An example is the lubricant film in roller bearings, i.e. Elasto-Hydrodynamic Lubrication.

The theoretical research involves modeling, development of efficient numerical solution algorithms and the use of these tools to derive general design rules for practical use. The experimental research employs a ball-on-disk apparatus and involves validation of predictions as well as the study of grease lubrication phenomena.

BIO-PHYSICAL FLOWS

This research deals with the flow in lungs, in particular the flow-induced deformation of the elastic lung tubes and the deposition of aerosols in lungs. Research is aimed at developing new diagnostic and therapeutic tools.

PREDICTION OF THE HYDRAULIC PERFORMANCE OF CENTRIFUGAL PUMPS

PROJECT LEADERS

NP Kruyt, HWM Hoeijmakers

RESEARCH THEME

Mathematical and computational methods for fluid flow analysis

PARTICIPANTS

RW Westra, NP Kruyt, K van Aniel, HWM Hoeijmakers

COOPERATIONS

Flowserve BV

FUNDED

Senter, UT

University 100 %

FOM -

STW -

NWO Other -

Industry -

TNO -

GTI -

EU -

Scholarships -

START OF THE PROJECT

1998

INFORMATION

NP Kruyt

053 489 2528

n.p.kruyt@utwente.nl

PROJECT AIM

The hydraulic performance of pumps is studied both numerically and experimentally. For the numerical flow simulation a potential-flow method has been developed for the flow inside centrifugal and mixed-flow pumps. The method includes loss models and a cavitation inception model. The method has been extended to include a transpiration-type of model for the effect of sheet cavitation. The experimental work is carried out in the new Rotating Flow facility.

PROGRESS

In 2013 further work has been carried out and publication of results has been realized. The Rotating Flow facility is being redesigned so that higher rotational speeds become possible.

DISSERTATIONS

-

SCIENTIFIC PUBLICATIONS

-

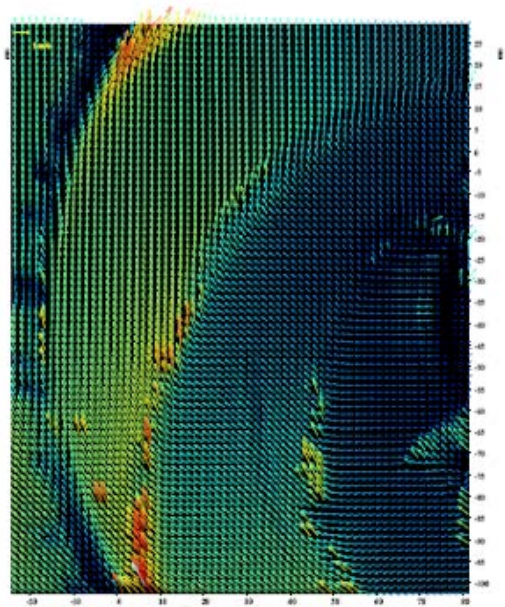
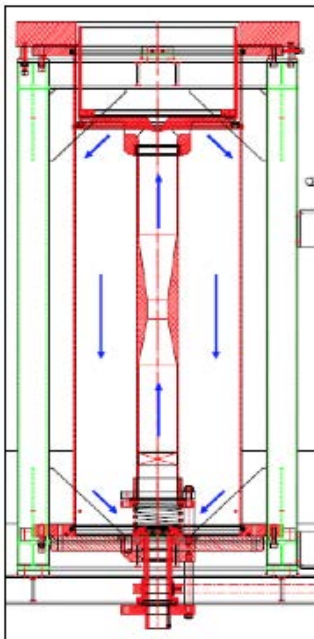

INVERSE DESIGN AND OPTIMISATION METHODS FOR CENTRIFUGAL PUMPS AND FANS

PROJECT AIM

Using the augmented potential-flow method developed for the prediction of the hydraulic performance of centrifugal and mixed flow pumps two types of design methods for three-dimensional configurations are investigated: (i) inverse-design methods and (ii) optimization methods. The validation of the computational methods has been carried out in the newly developed Rotating Flow facility, by PIV-measurements of the relative velocity field.

PROGRESS

A three-dimensional inverse-design method for impellers of centrifugal pumps has been developed, by which an impeller geometry is obtained that meets the prescribed hydraulic characteristics (rotational speed, flow rate, head and loading). Optimisation methods have been developed in which the performance of centrifugal pump impellers is optimised with respect to required head, low losses and optimal cavitation characteristics. The relative velocity field has been measured at various operating conditions using PIV, in the newly developed Rotating Flow facility. A publication has been effected.

DISSERTATIONS

-

SCIENTIFIC PUBLICATIONS

-

PROJECT LEADERS

NP Kruyt, HWM Hoeijmakers

RESEARCH THEME

Mathematical and computational methods for fluid flow analysis

PARTICIPANTS

RW Westra, NP Kruyt, K van AnDEL, HWM Hoeijmakers

COOPERATIONS

Flowserve BV, Urenco Aerospace, Johnson Pump, IHC Parts & Services, NLR, Marin

FUNDED

| | |
|--------------|-------|
| STW, UT | |
| University | - |
| FOM | - |
| STW | 100 % |
| NWO Other | - |
| Industry | - |
| TNO | - |
| GTI | - |
| EU | - |
| Scholarships | - |

START OF THE PROJECT

2003

INFORMATION

NP Kruyt

053 489 2528

n.p.kruyt@utwente.nl



PROJECT LEADERS

HWM Hoeijmakers, A Hirschberg

RESEARCH THEME

Mathematical and computational methods for fluid flow analysis

PARTICIPANTS

H de Vries, ETA van der Weide,
A Hirschberg, HWM Hoeijmakers

COOPERATIONS

ECN

FUNDED

ECN, UT

University 30 %

FOM -

STW -

NWO Other -

Industry -

TNO -

GTI 70 %

EU -

Scholarships -

START OF THE PROJECT

2000

INFORMATION

HWM Hoeijmakers

053 489 4838

h.w.m.hoeijmakers@utwente.nl

PROJECT AIM

CFD methods for unsteady flows are developed for the aero-elastic behavior of flexible wind turbine blades. The methods considered range from inviscid flow methods coupled to boundary-layer methods to time-accurate RANS methods. The flow conditions to be considered include cases with dynamic stall. Means for flow control are explored, both experimentally and computationally.

PROGRESS

In 2013 the development of a high-fidelity computational method was finished by completing the PhD thesis. ISBN 987-90-365-0006-7. Also in 2013 experimental research has been conducted on means for flow control: synthetic jets (SJA's) and Plasma Actuators (PA's). For SJA's it is now possible to achieve maximum outflow velocities up to 60 m/s. Employing PA's that produce a wall jet and two opposing PA's that produces a jet normal to the wall the maximum velocities are in the range of 5 to 10 m/s.

DISSERTATIONS

1. H. de Vries: On Synthetic Jet Actuation for Aerodynamic Load Control. ISBN 987-90-365-0006-7.

SCIENTIFIC PUBLICATIONS

-

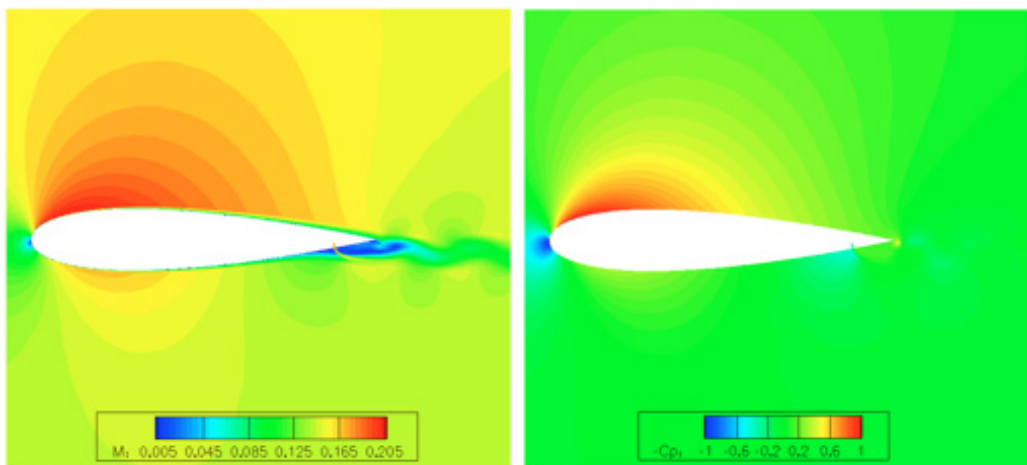

ADVANCED WIND TURBINE BLADE OPTIMIZATION

PROJECT AIM

Development of an aerodynamic analysis tools and integration of these tools into a gradient based optimization framework such that the performance of wind turbine blades can be optimized according to a (user defined) objective function.

PROGRESS

as well as for 3D subsonic flows. These tests show that the method performs as expected. Also an analysis using overset grids was performed for a wind turbine blade. Although it was possible to obtain the solution with the implicit machinery developed, this case showed that the resulting linear systems are rather difficult to solve using iterative methods.

DISSERTATIONS

-

SCIENTIFIC PUBLICATIONS

-

PROJECT LEADERS

HWM Hoeijmakers, ETA van der Weide

RESEARCH THEME

Mathematical and computational methods for fluid flow analysis

PARTICIPANTS

SH Jongsma, ETA van der Weide, HWM Hoeijmakers

COOPERATIONS

Suzlon Blade Technology

FUNDED

Suzlon Blade Technology

University -

FOM -

STW -

NWO Other -

Industry 100 %

TNO -

GTI -

EU -

Scholarships -

START OF THE PROJECT

2008

INFORMATION

ETA van der Weide

053 489 2593

e.t.a.vanderweide@utwente.nl

Solution of an aerodynamic shape optimization problem for a wing subject to transonic flow conditions.

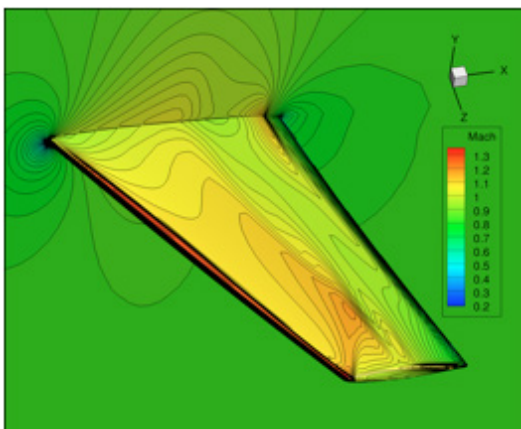

Contour plot of the pressure for the flow around a model wind turbine rotor, rotating with a constant angular velocity.

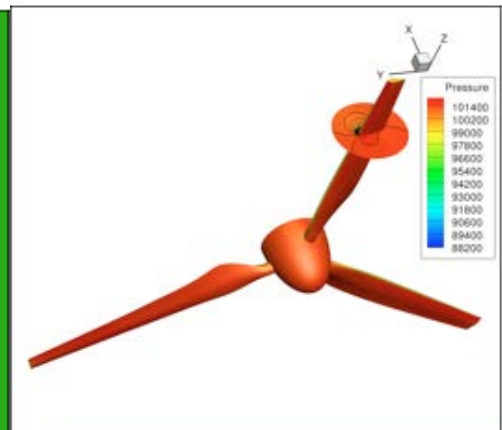

PROJECT LEADERS

HWM Hoeijmakers, ETA van der Weide

RESEARCH THEME

Mathematical and computational methods for fluid flow analysis

PARTICIPANTS

ETA van der Weide, HWM Hoeijmakers

COOPERATIONS

-

FUNDED

EU (CleanSky Project)
 University 50 %
 FOM -
 STW -
 NWO Other -
 Industry -
 TNO -
 GTI -
 EU 50 %
 Scholarships -

START OF THE PROJECT

2009

INFORMATION

ETA van der Weide
 053 489 2593
 e.t.a.vanderweide@utwente.nl

PROJECT AIM

Investigate the possibility to apply synthetic jet flow control on the flaps of aircraft wings in order to increase the lift during take off and landing. The goal of this research is to determine the specifications of a synthetic jet flow control device in order to accomplish the desired effects.

PROGRESS

A careful analysis for steady blowing has been carried out, which indicated that the actual gain in lift for the IACD (Integrated Active Component Demonstrator), the demonstrator of the Dutch consortium within the CleanSky project, is relatively small (maximum 5 percent increase). However, the actual actuator to be used is a pulsed jet actuator, which may give a better performance. When the actual details of this actuator are known, further (unsteady) simulations will be performed.

DISSERTATIONS

-

SCIENTIFIC PUBLICATIONS

-

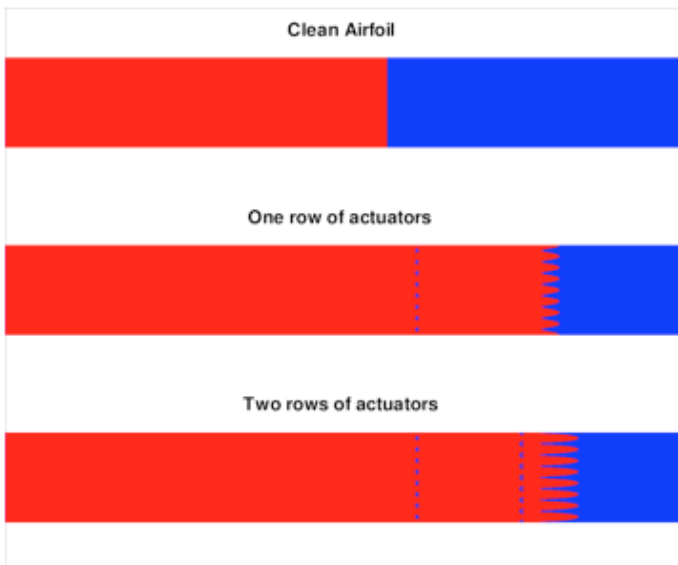

Top view of the separation length for the clean airfoil, one row of actuators and two rows of actuators. Red is attached flow, blue is separated flow. The flow is from left to right.

ICE ACCRETION ON AIRCRAFT WINGS

PROJECT AIM

Numerical simulation of ice accretion on aircraft wings in flight at (extreme) icing conditions, including effects of splashing of large super-cooled droplets on impact, droplet breakup in high-shear regions of the flow, droplet coalescence.

PROGRESS

Starting point has been a potential flow method coupled to a Lagrangian method to predict the water collection efficiency and to Messinger's model for the freezing thin layer of water along the surface. This method has been extended to poly-disperse droplet distributions and the capability to treat multi-element airfoil sections. Also a splashing-droplet model as well as a bouncing-droplet model has been adapted and implemented. Furthermore an Eulerian method for predicting the water collection efficiency has been developed, which is more suitable for complex configurations. Furthermore an unstructured-grid Euler method for compressible flow has adapted for coupling to the ice-accretion models. The method has been extended to ice accretion on 3D swept wings.

DISSERTATIONS

1. JM Hospers: Eulerian Method for Super-Cooled Large Droplet Ice-Accretion on Aircraft Wings. ISBN 987-90-365-0006-7.

SCIENTIFIC PUBLICATIONS

1. E. Norde, JM. Hospers, E. van der Weide, HWM. Hoeijmakers: Splashing model for impact of supercooled large droplets on a thin liquid film. AIAA Paper 2014-0738.

PROJECT LEADERS

HWM Hoeijmakers

RESEARCH THEME

Mathematical and computational methods for fluid flow analysis

PARTICIPANTS

JM Hospers, HWM Hoeijmakers

COOPERATIONS

TU Darmstadt, CIRA, INTA, ONERA

FUNDED

| | |
|--------------|------|
| EU, UT | |
| University | 20 % |
| FOM | - |
| STW | - |
| NWO Other | - |
| Industry | - |
| TNO | - |
| GTI | - |
| EU | 80 % |
| Scholarships | - |

START OF THE PROJECT

2008

INFORMATION

HWM Hoeijmakers

053 489 4428

h.w.m.hoeijmakers@utwente.nl

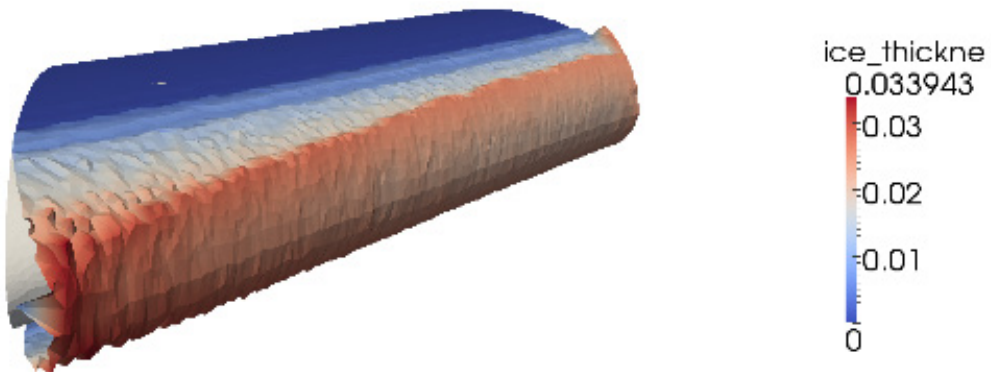

PROJECT LEADERS

HWM Hoeijmakers, A Hirschberg

RESEARCH THEME

Complex dynamics of fluids

PARTICIPANTS

H Hirschberg

COOPERATIONS

TNO, VKI, TUDelft, LMS (Be)

FUNDED

University, Aether project (EC),

Flowairs project (EC)

University 25 %

FOM -

STW -

NWO Other -

Industry -

TNO -

GTI -

EU 75 %

Scholarships -

START OF THE PROJECT

200

INFORMATION

HWM Hoeijmakers

053 489 4838

h.w.m.hoeijmakers@utwente.nl

PROJECT AIM

Investigate experimentally the flow over discontinuities, cavities, airfoils, blunt bodies, etc. For this purpose the existing 0.9*0.7 m² (50 m/s) closed test section aerodynamic wind tunnel has been developed to an Aero-Acoustic Test facility (silent wind tunnel) with 0.9*0.7 m² (65 m/s) open jet test section within a 6x6x4m³ anechoic chamber.

PROGRESS

The aeroacoustic response of a diffuser has been studied (Msc thesis B. Molenaar).

DISSERTATIONS

-

SCIENTIFIC PUBLICATIONS

1. O. Rudenko, G. Nakiboglu, A. Holten, A. Hirschberg, "Corrugated pipe segment with anechoic termination: critical Mach number for whistling" 19th AIAA/CEAS Aeroacoustics Conference (34th AIAA Aeroacoustics Conference), Berlin, Germany, 27-29 May 2013.
2. G. Nakiboglu, O. Rudenko, A. Hirschberg, "Hydrodynamic interference in corrugated pipe whistling", ICSV 20, Bangkok, Thailand, 7-13 July 2013.
3. O. Rudenko, D. Mertens, G. Nakiboglu, A. Hirschberg, S. Belfroid, "A linear model for the onset of whistling in corrugated pipe segments: influence of the geometry", Pressure Vessels & Piping Division Conference ASME, PVP29013, Paper No PVP2013-97273, 14-18 July 2013, Paris.
4. O. Rudenko, G. Nakiboglu, A. Hirschberg, "On whistling of pipes with a corrugated segment: Experiment and theory", Journal of Sound and Vibration 332, 7226 (2013). DOI: 10.1016/j.jsv.2013.08.034.
5. O. Rudenko, G. Nakiboglu, A. Hirschberg, "Onset of Flow Induced Tonal Noise in Corrugated Pipe Segments", J. Pressure Vessel Technol. (), (Jan 01, 2014)doi:10.1115/1.4026595.
6. D. Tonon, E. Moers, A. Hirschberg, "Quasi-steady acoustic response of wall perforations subject to a grazing-bias flow combination", J. Sound Vib. 332 (2013) 1654-1673.

Zijaanzicht nieuwe situatie

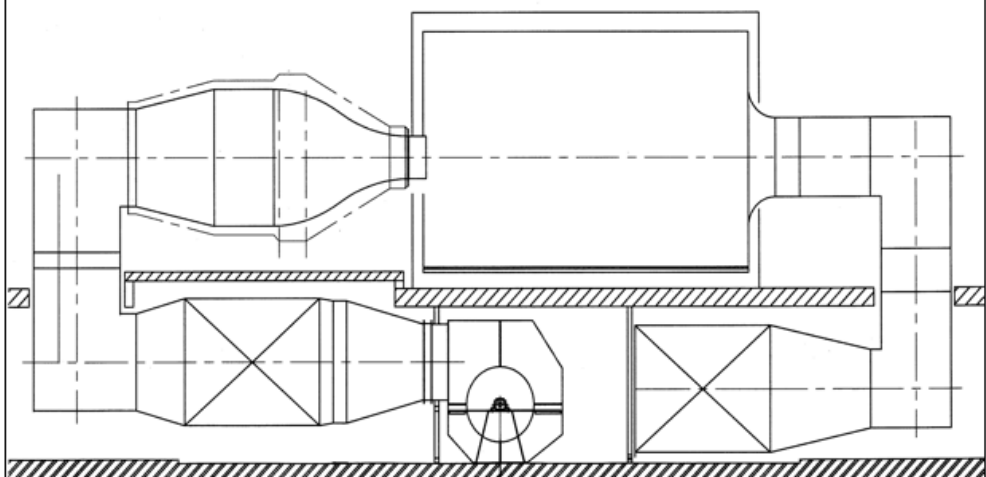

COPA-GT, STUDY OF HIGHER ORDER ENERGY-STABLE DISCRETIZATION TECHNIQUE FOR TURBOMACHINERY APPLICATIONS

PROJECT AIM

The research is theoretical/numerical and focuses on the development of an highly efficient parallel multiblock structured code for turbomachinery applications. The goal is to assess whether or not high order energy stable schemes are more efficient for such problems. In fact, the most widely used commercial codes typically provide a 2nd order accurate discretization of the Navier-Stokes equations. The question is if it possible to obtain the same solution making use of high order (≥ 3 rd) numerical methods and at the same time reducing the number of points of the numerical grid. This would lead to large saving in terms of computational time.

PROGRESS

The high order discretization has been compared to other high order discretization during the workshop for high order schemes in Cologne. Very good results have been obtained on both accuracy and efficiency for complex test cases (see figures below). Furthermore, high order implicit time integration schemes of the ESDIRK type have been implemented in the code as well as validated. These schemes are essential for the actual goal of this project, namely the application of the high order schemes to turbomachinery applications. Also a start is made with the implementation of RANS turbulence models, because LES for a multi-stage compressor/turbine is simply unaffordable in terms of CPU requirements.

DISSERTATIONS

-

SCIENTIFIC PUBLICATIONS

-

ILES of transitional flow over a SD7003 wing:
isosurfaces of Q-criterion ($Re=6e+4$, $Ma=0.1$, $\alpha=8^\circ$).

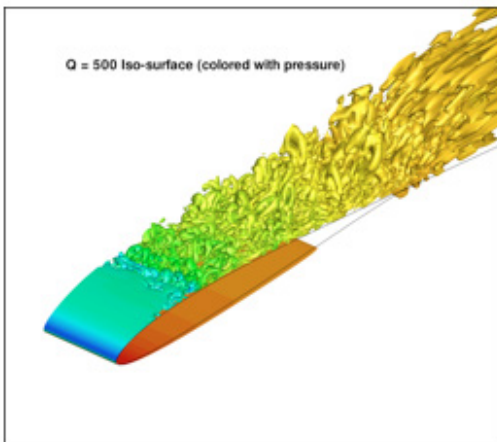

3D body of revolution: C_p contours ($Re=5e+3$, $Ma=0.5$, $\alpha=1^\circ$, laminar).

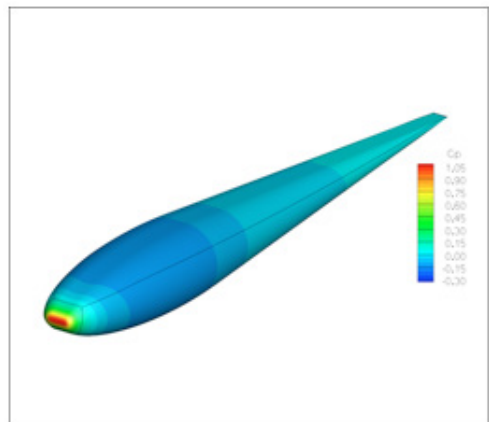

PROJECT LEADERS

HWM Hoeijmakers, ETA van der Weide

RESEARCH THEME

Mathematical and computational methods for fluid flow analysis

PARTICIPANTS

G Giangaspero, ETA van der Weide, HWM Hoeijmakers

COOPERATIONS

VKI, Cerfacs, RWTH, Turbomeca, BSC, Siemens, Loughborough Univ

FUNDED

| | |
|--------------|------|
| EU | |
| University | 25 % |
| FOM | - |
| STW | - |
| NWO Other | - |
| Industry | - |
| TNO | - |
| GTI | - |
| EU | 75 % |
| Scholarships | - |

START OF THE PROJECT

2012

INFORMATION

ETA van der Weide
053 489 2593
e.t.a.vanderweide@utwente.nl

HAIC, HIGH ALTITUDE ICE CRYSTALS

PROJECT LEADERS

HWM Hoeijmakers, ETA van der Weide

RESEARCH THEME

Mathematical and computational methods for fluid flow analysis

PARTICIPANTS

E Norde, ETA van der Weide, HWM Hoeijmakers

COOPERATIONS

Onera, CIRA, EADS, Darmstadt Univ., TsAGI

FUNDED

| | |
|--------------|------|
| EU | |
| University | 25 % |
| FOM | - |
| STW | - |
| NWO Other | - |
| Industry | - |
| TNO | - |
| GTI | - |
| EU | 75 % |
| Scholarships | - |

START OF THE PROJECT

2013

INFORMATION

ETA van der Weide
053 489 2593
e.t.a.vanderweide@utwente.nl

PROJECT AIM

Numerical simulation of ice accretion in the first stages of a compressor of an aircraft engine due to the presence of ice crystals at high altitude. The Eulerian approach for predicting the droplet trajectories will be used, combined with the (modified) Messinger model for the actual ice accretion.

PROGRESS

An intensive literature study has been carried out and a report has been written to start the project. Following this decisions were taken on the implementation of the Eulerian approach for predicting the droplet trajectories. It was agreed to use the sectional method, i.e. the usage of several bins, to simulate the different particle sizes. Afterwards the actual implementation in an existing parallel CFD code was started. It is expected that the physics of ice accretion can be divided into a number of steps: partial melting of ice crystals due to the warm airflow inside the engine (1), the water film on the surface captures the ice particles (2), the mixture of ice and liquid on the surface forms into ice (3).

DISSERTATIONS

-

SCIENTIFIC PUBLICATIONS

1. Ice accretion on a NACA-0012 airfoil as a result of SLD (supercooled large droplets) impingement. In this test case three different deposition models were compared to capture the splashing behavior of SLD.

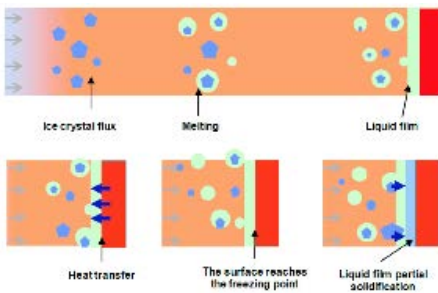

Ice-crystal icing scenario. Source: F. Dezitter, A. Grandin, et al., HAIC (High Altitude Ice Crystals), AIAA Paper 2013-2674.

Ice accretion NACA-0012 airfoil. Source: E. Norde, J.M. Hospers et al., Splashing model for impact of supercooled large droplets on a thin liquid film, AIAA Paper 2014-0738. Experiments conducted by DGA Aero-engine testing, France.

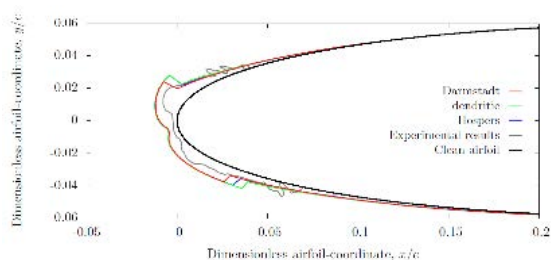

DYNVOR : THE DYNAMICS OF VORTEX CAVITATION ON SHIP PROPULSORS AND PUMP IMPELLERS

PROJECT AIM

The aim of this project is: (i) to enhance the understanding of the contribution of cavitating vortices to cavitation vibration and cavitation erosion and (ii) to develop a simulation code capable of predicting flows with cavitating vortices. It is believed that Large Eddy Simulation (LES) for the modeling of turbulence is a key tool for the success of such a simulation code. Typical applications where this type of flow occurs are flows around ship propulsors and flows in pumps.

PROGRESS

An LES computation for a non-cavitating case has been carried out using the high order schemes. The results of this computation are very good, which confirms the expectation that these schemes are well suited for such simulations. However, the formulation used cannot be used as such for the simulations with cavitation, because of the presence of discontinuities in the flow field. Therefore a higher order WENO scheme is under construction, which should be able to resolve this issue. The 1D results for this WENO scheme are very encouraging.

DISSERTATIONS

1. AI Oprea: Prediction of Tip Vortex Cavitation Prediction for Ship Propellers. ISBN 987-90-365-35793.

SCIENTIFIC PUBLICATIONS

1. F. Khatami, E. van der Weide and H. Hoeijmakers. Multi-phase thermodynamic tables for efficient numerical simulation of cavitating flows: A novel approach towards optimized accurate tables. Proceedings of the 8th International Conference on Multiphase Flow, ICMF 2013, Jeju, Korea, May 2013.

PROJECT LEADERS

HWM Hoeijmakers, ETA van der Weide

RESEARCH THEME

Mathematical and computational methods for fluid flow analysis

PARTICIPANTS

F Khatami, ETA van der Weide, HWM Hoeijmakers

COOPERATIONS

Wärtsilä, IHC Merwede, Flowserve

FUNDED

| | |
|--------------|------|
| AgentschapNL | |
| University | - |
| FOM | - |
| STW | - |
| NWO Other | - |
| Industry | 25 % |
| TNO | - |
| GTI | - |
| EU | 75 % |
| Scholarships | - |

START OF THE PROJECT

2011

INFORMATION

ETA van der Weide
053 489 2593
e.t.a.vanderweide@utwente.nl

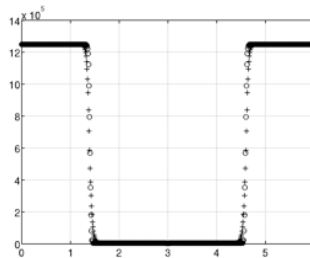
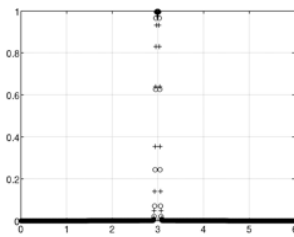

Cavitating expanding waves simulations using MUSCL (+), and a developed positivity-preserving WENO scheme (o), left: vapor void fraction, right: pressure.

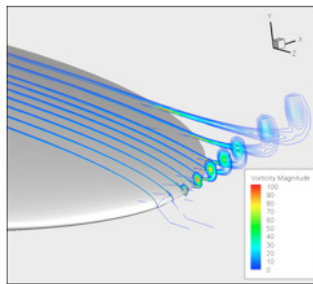
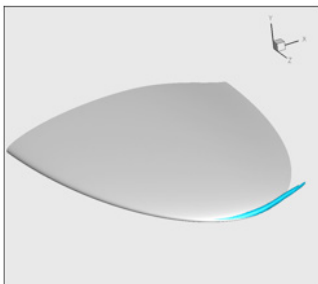

Tip vortex cavitation simulations on the elliptic Arndt's hydrofoil using the MUSCL scheme, left: vapor void fraction isosurface ($\alpha=0.2$), right: vorticity magnitude.

PROJECT LEADERS

HWM Hoeijmakers

RESEARCH THEME

Mathematical and computational methods for fluid flow analysis

PARTICIPANTS

JJ Slot, HWM Hoeijmakers

COOPERATIONS

TUD, Tue, Shell, FMC Separation Systems, Frames, Wintershall, WUR

FUNDED

| | |
|--------------|------|
| ISPT, UT | |
| University | 20 % |
| FOM | - |
| STW | - |
| NWO Other | - |
| Industry | 80 % |
| TNO | - |
| GTI | - |
| EU | - |
| Scholarships | - |

START OF THE PROJECT

2008

INFORMATION

HWM Hoeijmakers
053 489 4428
h.w.m.hoeijmakers@utwente.nl

PROJECT AIM

Modeling and numerical simulation of swirling flow of oil/water mixtures aimed at separation. An experimental set-up is developed at TU Delft for experimental investigation of these flows and providing data for validation. At Wageningen University the behavior of oil-water mixtures is studied at the micro-scale, including droplet coalescence and the effect of surfactants.

PROGRESS

Using CFD, the single-phase swirling water flow in the inline bulk oil-water separator has been considered in detail and agree with experimental measurements. The results show a complex flow pattern with regions of reversed flow. Two-fluid models are employed to study the flow field and separation characteristics. Two-phase experiments are carried out and it will be used to validate the numerical models for these flows. Evolution of the droplet size distribution of the dispersed oil phase will be computed using populations balance models.

DISSERTATIONS

1. JJ Slot: Development of a Centrifugal In-Line Separator for Oil-Water Flows.: ISBN 987-90-365-3542-7.

SCIENTIFIC PUBLICATIONS

1. JJ Slot, LJAM Campen, HWM Hoeijmakers, RF Mudde: Development of a Centrifugal In-line Separator for Oil-Water Flows' (USB). In M.H. Kim (Ed.), Conference Proceedings 8th International Conference on Multiphase Flow, ICMF2013. Paper 934.

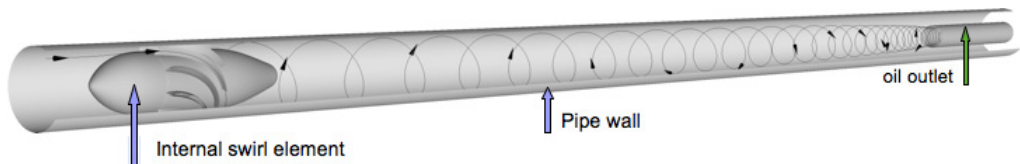

MULTIPHASE FLOW EFFECTS IN COMPACT PRODUCED-WATER TREATMENT EQUIPMENT

PROJECT AIM

The physical phenomena occurring during produced-water treatment are studied numerically. Oil droplet, and gas bubble trajectories will be predicted employing Lagrangian particle tracking for both swirling flow and settling conditions. Influence of effects such as a history term are required for prediction of trajectories. Collision and coalescence are important factors for advanced compact produced-water treatment. Occurrence of such effects is predicted making use of droplet and bubble trajectories.

PROGRESS

A Lagrangian particle tracking method has been developed for generic flow fields. Both implicit Crank-Nicolson, and explicit fourth order Runge-Kutta schemes have been implemented. History force has been identified as force that needs to be investigated. A new expression for the history kernel has been obtained using experimental data from literature to improve existing Reynolds dependent kernel. Efficient collision detection has been implemented in particle tracking code. Two Lattice Boltzmann Methods for liquids have been developed, one using a BGK approach with a body force pressure correction, the other using a BBGKY approach, to investigate the history force in detail. Both explicit and implicit schemes have been implemented. 2-D flow about a cylinder has been investigated to explore the method, and the method has been extended to 3-D flow about a sphere.

DISSERTATIONS

-

SCIENTIFIC PUBLICATIONS

1. DF van Eijkeren, HWM Hoeijmakers: The Influence of the History Force in Lagrangian Particle Tracking Applied to Swirling Flow Produced Water Treatment' (USB). In M.H. Kim (Ed.), Conference Proceedings 8th International Conference on Multiphase Flow, ICMF2013, Paper 644.

PROJECT LEADERS

HWM Hoeijmakers

RESEARCH THEME

Mathematical and computational methods for fluid flow analysis

PARTICIPANTS

DF van Eijkeren, HWM Hoeijmakers

COOPERATIONS

FMC Technologies – Separation Systems, FACE (SINTEF)

FUNDED

FMC Technologies – Separation Systems, FACE (SINTEF)

| | |
|--------------|-------|
| University | - |
| FOM | - |
| STW | - |
| NWO Other | - |
| Industry | 100 % |
| TNO | - |
| GTI | - |
| EU | - |
| Scholarships | - |

START OF THE PROJECT

2009

INFORMATION

DF van Eijkeren
053 489 2482
d.f.vaneijkeren@utwente.nl

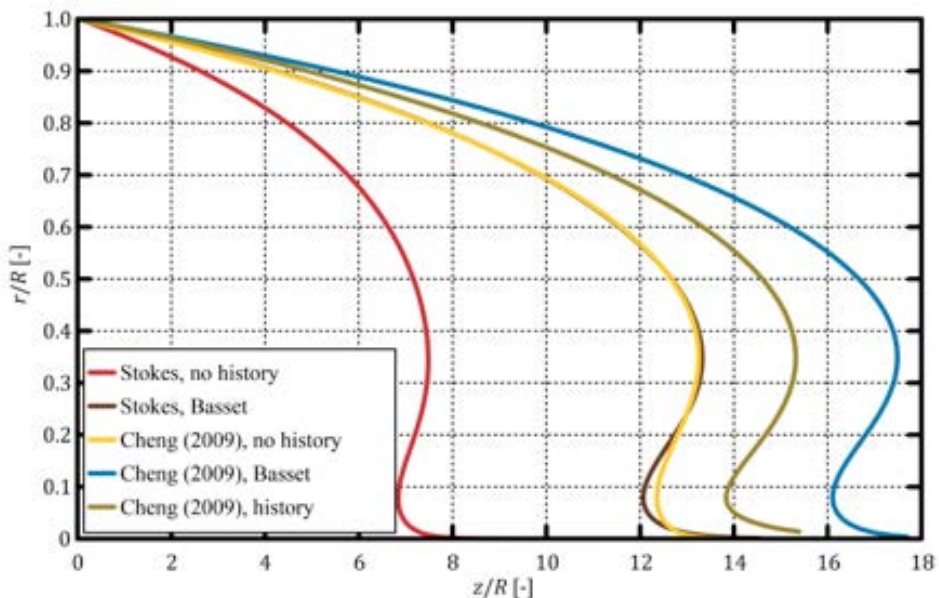

PROJECT LEADERS

CH Venner, HWM Hoeijmakers

RESEARCH THEME

Mathematical and computational methods for fluid flow analysis

PARTICIPANTS

CH Venner, HWM Hoeijmakers, H Boffy, M van Zoelen (SKF) PM Lugt (SKF), J Snoeijer (PoF, UT), J Wang (Qingdao), AA Lubrecht (INSA)

COOPERATIONS

Physics of Fluids, UT/TN INSA-de Lyon, France. Technical University of Brno, Czechia Qingdao Technological University, PR. China, SKF ERC, Netherlands

FUNDED

| | |
|--------------|------|
| University | 50 % |
| FOM | - |
| STW | - |
| NWO Other | - |
| Industry | 50 % |
| TNO | - |
| GTI | - |
| EU | - |
| Scholarships | - |

START OF THE PROJECT

2007

INFORMATION

CH Venner
053 489 2488
c.h.venner@utwente.nl

Computed interferograms of the film thickness in a circular EHL contact for pure squeeze (impact) (left), Contact pressure in the contact between 3D heterogeneous material with soft and hard inclusions (center) and polychristalline model with ellipsoidal inclusion (right)

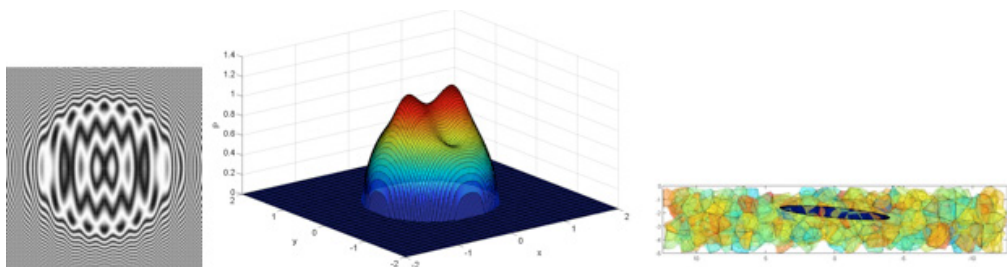

PROJECT AIM

Development of accurate thin film/layer flow models and numerical simulation algorithms for the prediction of lubricant film formation capacity and lubrication life in rolling element bearing contacts in relation to operating conditions, lubricant rheology (oil-grease), supply conditions (starved-flooded), and material properties.

PROGRESS

Fundamental aspects and self-similarity in transient EHL contacts under squeeze conditions are studied with relevance cam-follower systems, and for soft lubrication and bubble collisions. Thin layer flow models for film decay in EHL contacts (bearings) have been further developed, validated, and applied. A Multigrid/Multilevel method was developed for high order compact discretization schemes. A novel Multilevel approach was developed which enables simultaneous solution of the contact problem in (strongly) heterogeneous materials. The efficiency allows detailed optimization of composite materials in (lubricated contact) applications. Another new development is the extension to near incompressible materials for applications in seals.

DISSERTATIONS

-

SCIENTIFIC PUBLICATIONS

1. N Biboulet, P Sperka, CH Venner, I Krupka: Obtaining the pressure Spike and Maximum Shear Stress from Optical Interferometry Data. *Tribology International*, V. 62, pp. 1-7. DOI: 10.1016/j.triboint.2013.01.018.
2. J Wang, CH Venner, AA Lubrecht: Influence of Surface Waviness on the Thermal Elastohydrodynamic Lubrication of an Eccentric-Tappet Pair, *ASME J. of Tribology*, V. 135(2), pp. 021001-021013.
3. J Wang, CH Venner, AA Lubrecht: Central film thickness prediction for line contacts under pure impact, *Tribology International*, V 66, pp. 203-207. DOI: 10.1016 /j.triboint.2013.05.011.
4. JH Snoeijer, J Eggers, CH Venner: Similarity theory of lubricated Hertzian Contacts, *Phys. Fluids*, V. 25, 101705; doi:10.1063/1.4826981.
5. PM Lugt, MT van Zoelen, CH Venner: Grease Lubrication in Single Contacts. Chapter 9 of "Grease Lubrication in Bearings". Bearings, Wiley, UK, ISBN 978-1-118-35391-2.
6. PM Lugt, MT van Zoelen, CH Venner: Grease Lubrication in Rolling Bearings. Chapter 10 of "Grease Lubrication in Bearings, Wiley, UK, ISBN 978-1-118-35391-2.

MULTISCALE ISLANDS MIXED LUBRICATION MODELING

PROJECT AIM

Development of a mixed lubrication model based on physical first principles representing relevant aspects on different scales to predict the behaviour of concentrated contacts as appearing between rolling elements and raceways in rolling element bearings under extreme operating conditions of very limited lubricant supply.

PROGRESS

High speed camera observations and result analysis of film thickness in and flow around the contact using optical interferometry. Identification and further analysis of characteristic aspects crucial for lubricant distribution and inflow to guide modeling. Detailed analysis of exit closed cavitation bubble and Modeling of cavitation potential in this region using lubrication flow models. It is shown that the bubble (cavity) is a true 3D phenomenon that cannot be explained using lubrication theory. Moreover, it is strongly determined by the transition from lubrication flow to the 3D surrounding flow of the contact. A developed Multilevel image segmentation algorithm for analysis of results has been applied to other engineering applications and shown to extend to 3D imaging data. Integrate models and results in Thesis.

DISSERTATIONS

-

SCIENTIFIC PUBLICATIONS

-

PROJECTLEADERS

CH Venner, HWM Hoeijmakers

RESEARCHTHEME

Mathematical and computational methods for fluid flow analysis

PARTICIPANTS

E van Emden, CH Venner, HWM Hoeijmakers, GE Morales-Espejel (SKF)

COOPERATIONS

SKF

FUNDED

| | |
|--------------|-------|
| SKF | |
| University | - |
| FOM | - |
| STW | - |
| NWO Other | - |
| Industry | 100 % |
| TNO | - |
| GTI | - |
| EU | - |
| Scholarships | - |

START OF THE PROJECT

2009

INFORMATION

CH Venner
053 489 2488
c.h.venner@utwente.nl

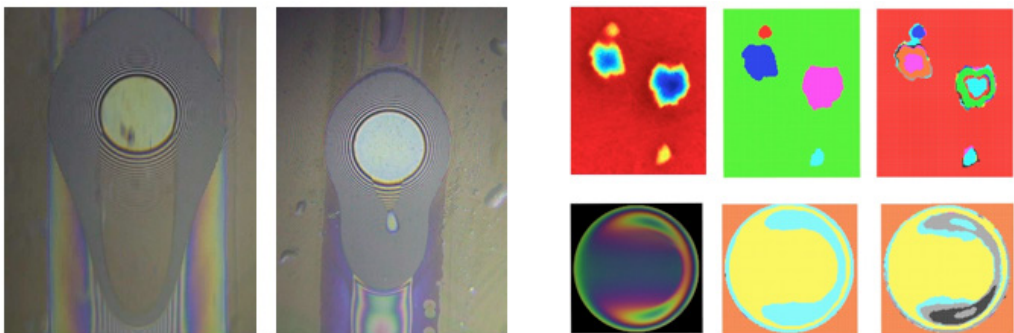

Interferometric image of contact and surrounding flow exhibiting extended cavitation bubble, and snapshot of collapsed bubble after sudden stop of motion (left). Model results of Multilevel Image segmentation for tribological images of surface damage, and lubricated contact (right)

PROJECT LEADERS

NP Kruyt

RESEARCH THEME

Mathematical and computational methods for fluid flow analysis

PARTICIPANTS

NP Kruyt

COOPERATIONS

University of Waterloo, Canada,
University of Leeds, Université
Joseph Fourier, Grenoble, France

FUNDED

| | |
|--------------|-------|
| UT | |
| University | 100 % |
| FOM | - |
| STW | - |
| NWO Other | - |
| Industry | - |
| TNO | - |
| GTI | - |
| EU | - |
| Scholarships | - |

START OF THE PROJECT

2003

INFORMATION

NP Kruyt
053 489 2528
n.p.kruyt@utwente.nl

PROJECT AIM

The study of the (micro-mechanical) behavior of slowly flowing granular materials, in particular of the relation between microscopic behaviour and the macroscopic, continuum behaviour.

PROGRESS

The accuracy of three-dimensional, micromechanical expressions for the strain tensor have been investigated. The most accurate one, due to Bagi, has been used to study the deformation characteristics of granular materials from the micromechanical viewpoint. Elastic properties of granular materials in the isotropic state have been investigated theoretically. Links between macroscopic plasticity and microscopic behaviour have been studied.

DISSERTATIONS

-

SCIENTIFIC PUBLICATIONS

1. O Millet, NP Kruyt, F Nicot: On the importance of particle rotations for macroscopic strains in granular assemblies. *Particles 2013*, Paper A37, Stuttgart, Germany.
2. NP Kruyt: The critical state of granular materials and its stability: a micromechanical view. *Particles 2013*, Paper A3, Stuttgart, Germany.
3. NP Kruyt, O Millet, F Nicot: From microstructure to the macroscopic strains in granular soils. *XVI French-Polish Colloquium of Soil and Rock Mechanics*, Montpellier, France.
4. NP Kruyt: Micromechanics of the critical state of idealised granular materials. *Constitutive Modeling of Geomaterials: Advances and New Applications*, pp. 193–198, eds. Q. Yang & J.-M. Zhang & H. Zheng & Y. Yao, Springer-Verlag, Berlin, Germany.

FLOW AND AEROSOL DEPOSITION IN HUMAN LUNGS

PROJECT AIM

Inhalation of therapeutic aerosols to treat lung diseases (e.g. asthma) is a problem since the upper airways (nose/mouth region) acts as a natural filter (especially for small subjects (e.g. children)). Results of in vitro measurements and CFD calculations show considerable differences. More over the difficult geometry and non stationair breathing patterns complicate the calculations. The ultimate aim is to predict how and which aerosols should be inhaled to maximize deposition in the required regions and avoid uper airway deposition in the individual patient.

PROGRESS

In the last year a master student (T. Huijgen) worked on his master thesis on CFD calculations for the flow and spray in inhalers and comparison with experiments.

DISSERTATIONS

-

SCIENTIFIC PUBLICATIONS

-

PROJECTLEADERS

HWM Hoeijmakers, FHC de Jongh

RESEARCHTHEME

Mathematical and computational methods for fluid flow analysis

PARTICIPANTS

FHC de Jongh, HWM Hoeijmakers

COOPERATIONS

MST, UVA-AMC, Medspray

FUNDED

| | |
|--------------|-------|
| UT | |
| University | 100 % |
| FOM | - |
| STW | - |
| NWO Other | - |
| Industry | - |
| TNO | - |
| GTI | - |
| EU | - |
| Scholarships | - |

START OF THE PROJECT

1998

INFORMATION

FHC de Jongh

053 489 4428

f.h.c.dejongh@utwente.nl

PROJECT LEADERS

NP Kruyt, HWM Hoeijmakers

RESEARCH THEME

Mathematical and computational methods for fluid flow analysis

PARTICIPANTS

BJ Konijn, NP Kruyt,
HWM Hoeijmakers

COOPERATIONS

TUD, IHC

FUNDED

| | |
|--------------------|------|
| Agentschap NL, IHC | |
| University | 20 % |
| FOM | - |
| STW | - |
| NWO Other | - |
| Industry | 80 % |
| TNO | - |
| GTI | - |
| EU | - |
| Scholarships | - |

START OF THE PROJECT

2011

INFORMATION

NP Kruyt
053 489 2528
n.p.kruyt@utwente.nl

PROJECT AIM

Aim of the project is to develop a CFD method for the modeling of dense-phase fluid-particulate flow. Firstly, experiments are carried out to determine the dependence of the properties of both liquid and particles on the fluid behavior. With the experimental results, constitutive equations will be constructed. These constitutive relations will be used to develop a CFD method that describes fluid-particulate flow.

PROGRESS

A literature study on fluid-particulate flow modeling and fluid-particulate flow experiments has been carried out. A rheometer is selected and acquired. Tests on flow behavior dependence on liquid and particle properties have been made. The influence of particle diameter, solid fraction, viscosity of carrying liquid on the effective viscosity has been determined. An outline of a CFD method for dense-phase suspensions is being developed.

DISSERTATIONS

-

SCIENTIFIC PUBLICATIONS

1. Konijn, B.J. & Sanderink, O.B.J. & Kruyt, N.P. (2013) Experimental study on the behaviour of suspensions. 8th International Conference on Multiphase Flow, Paper 433, Jeju, Korea.

OOGSPRAY: SPRAYEN, NIET DRUPPELEN

PROJECT AIM

The aim of the project is to develop a numerical simulation model for a turbulent spray which is created by the Rayleigh breakup mechanism, and to use this model to improve the understanding of industrially applied sprays and to support the design of a spray device for eye-treatment.

PROGRESS

The project has been completed. A numerical model based on Large Eddy simulation on a cartesian uniform grid has been developed together with a Lagrangian model for the transported droplets based on Stokes drag force. An investigation in terms of dimensionless numbers has been carried out to support the design of an eye-spray device. Currently it is investigated whether the developed algorithm can be employed within research on aerosol deposition in the pulmonary airways by treating the boundary conditions by means of the immersed boundary method.

DISSERTATIONS

-

SCIENTIFIC PUBLICATIONS

-

PROJECTLEADERS

R Hagmeijer, FHC de Jongh

RESEARCHTHEME

Complex dynamics of fluids

PARTICIPANTS

PJ van Dijk, R Hagmeijer

COOPERATIONS

Med spray BV

FUNDED

Med spray BV

University 50 %

FOM -

STW -

NWO Other -

Industry 50 %

TNO -

GTI -

EU -

Scholarships -

START OF THE PROJECT

2011

INFORMATION

R Hagmeijer

053 489 5605

r.hagmeijer@utwente.nl

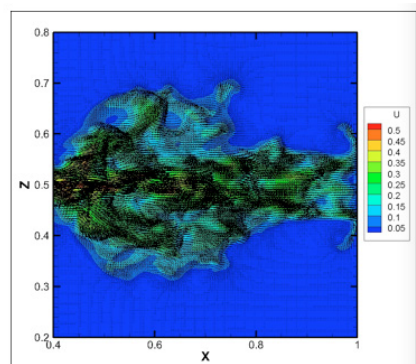
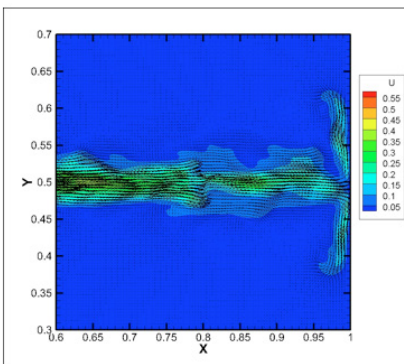

PROJECT LEADERS

HWM Hoeijmakers

RESEARCH THEME

Complex dynamics of fluids

PARTICIPANTS

RJ Musters, HWM Hoeijmakers,
ETA van der Weide

COOPERATIONS

-

FUNDED

| | |
|--------------|-------|
| UT | |
| University | 100 % |
| FOM | - |
| STW | - |
| NWO Other | - |
| Industry | - |
| TNO | - |
| GTI | - |
| EU | - |
| Scholarships | - |

START OF THE PROJECT

2012

INFORMATION

HWM Hoeijmakers
053 489 4838
h.w.m.hoeijmakers@utwente.nl

PROJECT AIM

Investigate experimentally and numerically the flow about nature-inspired configurations, such as the Robot Birds of Robert Musters. These nature-inspired copies of real birds combine lift and propulsion by flapping wings. In the project (scale-models of) these, and others, configurations are investigated in the wind tunnel and numerically.

PROGRESS

Wind-tunnel experiments have been carried out for a flexible model of the wing of the peregrine bird carrying out a flapping motion similar to the true motion. From the velocity distribution measured employing a wake rake, it is shown that the time-averaged streamwise velocity distribution shows a jet-like pattern. This corresponds to results obtained from numerical simulations (for 2D sections at three spanwise stations) for this wing. These results of numerical simulation have correlated the jet-like pattern with the inverted von Karman vortex street. Such a flow field configuration is associated with a specific phase difference between the heave and pitch motion of the wing.

DISSERTATIONS

-

SCIENTIFIC PUBLICATIONS

1. SA Hartman, HWM Hoeijmakers, RJ Musters: Experimental Investigation of Flow about Wing of Robot Bird (on line) (Paper no. AIAA 2012-0055). In Conference Proceedings 50th AIAA Aerospace Sciences Meeting including the New Horizons Forum and Aerospace Exposition (pp. 1-19). Reston, Virginia, USA: AIAA.

Robot-birds created by Robert Musters. From left to right: the Bald Eagle, the Peregrine Falcon and the Hawk.

Source: <http://www.greenx.nl>





Prof.dr.ir. ThH van der Meer

The research activities of the Thermal Engineering Group mainly concentrate on thermal conversion processes for industrial applications from the disciplines thermodynamics, transport phenomena and fluid mechanics. The research aims at an increasing use of renewable fuels, and at a more efficient and clean utilization of fossil fuels. The projects are organized around three central themes: thermal conversion processes of fuels, turbulent gaseous combustion and thermo-acoustics, and instationary heat transfer.

The research theme thermal conversion processes of fuels is part of the research programme of the OSPT (research school on process technology)

The research theme Turbulent gaseous combustion and thermo-acoustics is related to questions on ignition, extinction, flame stability, pollutant formation, combustion noise and its interaction with the combustion chamber structure. Numerical models are developed (within CFX), and experimental research is done like flow visualisation, acoustic measurements and laser diagnostics like laser induced fluorescence and Ramen/Rayleigh spectroscopy for the in-flame measurements of temperature and species concentrations. the underlying physical-chemical processes. Currently a large EU-project, named LIMOUSINE, with three PhD's and a post doc is ongoing on the topic of thermo-acoustics in gas turbines. Next there are several projects within the STW perspective program Clean Combustion Concepts.

The research theme "instationary heat transfer" is related to heat transfer in piston compressors, a pulsed compression reactor and new materials for enhanced heat transfer in regenerators and heat exchangers based on carbon nano-fibers attached to the heat transfer surface.

THE SOUND SOLUTION FOR SMALL SCALE RESIDENTIAL ENERGY CONVERSION

PROJECT AIM

As efficient usage of resources becomes more and more important because of their finiteness, one way to efficiently use energy is micro combined heat and power generation (micro-CHP). Therefore, Stirling engines raised interest for the domestic use of micro-CHP in recent years. Despite the promise of high efficiency due to the underlying Stirling cycle, these engines often have reliability problems because of their numerous moving parts. The engine under investigation makes use of a thermodynamic cycle similar to Stirling, but with less moving parts, therefore having a much higher reliability. Thus, we focus on the optimization of a thermoacoustic engine for application within a micro-CHP appliance.

PROGRESS

The work on the simulation and optimization of jet pumps has been continued. For this purpose, a time-domain impedance boundary condition is implemented and successfully tested for use in ANSYS CFX. Furthermore, the experimental thermoacoustic setup has been taken into use and a first investigation on flow visualization of oscillating flow around an orifice has been performed (see Figure 1). Additionally, a CFD model was derived to describe entrance effects at the end of the heat exchanger regenerator assembly, the core of thermoacoustic engines. The flow field was revealed for a reduced model and the heat pumping process was described.

DISSERTATIONS

-

SCIENTIFIC PUBLICATIONS

1. Bühler, S., Wilcox, D., Oosterhuis, J. P., and van der Meer, T. H. (2013). "Calculation of thermoacoustic functions with computational fluid dynamics," Proc. Meet. Acoust. Vol. 19, 19, doi:10.1121/1.4799088.
2. Oosterhuis, J. P., Bühler, S., Wilcox, D., and van der Meer, T. H. (2013). "Computational fluid dynamics simulation of Rayleigh streaming in a vibrating resonator," Proc. Meet. Acoust. Vol. 19, ASA, Montréal, doi:10.1121/1.4799051.

PROJECT LEADERS

TH van der Meer

RESEARCH THEME

Complex dynamics of fluids

PARTICIPANTS

S Bühler, JP Oosterhuis

COOPERATIONS

-

FUNDED

| | |
|---------------|------|
| Agentschap NL | 60 % |
| University | - |
| FOM | - |
| STW | - |
| NWO Other | - |
| Industry | 40 % |
| TNO | - |
| GTI | - |
| EU | - |
| Scholarships | - |

START OF THE PROJECT

2011

INFORMATION

TH van der Meer

053 489 2562

t.h.vandermeer@utwente.nl



Example of oscillating flow around an orifice, smoke visualization.

HITAC BOILER: HEAVY FUEL-OIL COMBUSTION IN A HITAC BOILER

PROJECT LEADERS

TH van der Meer

RESEARCH THEME

Mathematical and computational methods for fluid flow analysis

PARTICIPANTS

S Zhu

COOPERATIONS

TU Delft, Stork Thermeq, Shell Global Solutions Int.

FUNDED

| | |
|--|------|
| STW, Nederlandse Vlamvereniging University | - |
| FOM | - |
| STW | 75 % |
| NWO Other | - |
| Industry | 25 % |
| TNO | - |
| GTI | - |
| EU | - |
| Scholarships | - |

START OF THE PROJECT

2009

INFORMATION

TH van der Meer
053 489 2562
t.h.vandermeer@utwente.nl

PROJECT AIM

The objective of this project is to investigate computationally the combustion of heavy fuel oil with high temperature air in conditions representative for oil combustion in a boiler. Spray combustion models will be developed and validated by a literature flame, by a laboratory flame at Delft University, and by an industrial field test in a 9 MW boiler performed at Stork Thermeq. The gathered knowledge will be used to exploit the principles of HiTAC to create conditions with low NOX formation, uniform heat flux and to optimize the water-steam cycle to create an economically attractive, robust and reliable boiler system.

PROGRESS

The simulations of the Delft spray burner have been completed. This completes this project. A thesis will be written based on simulations of the 9 MWatt boiler from Stork and the Delfts spray burner.

DISSERTATIONS

-

SCIENTIFIC PUBLICATIONS

-

COPA-GT : COUPLED PARALLEL SIMULATION OF GAS TURBINES

PROJECT AIM

Until now, gas turbines have been designed following individual pathways for each component and each physical phenomenon. Nevertheless, the behavior of the individual components can be very different from their behavior when mounted together in an engine. To overcome this disadvantage, the numerical simulation of the entire engine with all physics involved is a key element for scientific progress and innovation. Developing numerical tools and methodologies to simulate the entire gas turbine with all physical effects is a new challenge and the overall scientific objective of the COPA-GT project.

PROGRESS

In the project European wide 13 PhD students and 5 Post Docs work under coordination of CERFACS in Toulouse. At the UT 3 PhD students are active. The project task of S. Gövert focuses on computationally efficiently modelling fluid structure interaction (FSI) in gas turbine combustors as embedded in full engine computations. In the first year, FSI simulations of the Limousine combustor with high structural flexibility have been performed using the ANSYS simulation environment. Due to limitations in customization and parallelization, the ALYA multiphysics code (developed at the Barcelona Supercomputing Center) has been chosen as an alternative tool. Emphasis has been set on developing the flow solver, by adding turbulence modelling and the CFI combustion model. After a thorough validation of the newly implemented models, FSI simulations of academic and industry type combustors are planned for the last year of the project.

DISSERTATIONS

-

SCIENTIFIC PUBLICATIONS

1. Gövert, S., Kok, J.B.W. and Roman Casado, J.C., 2013. "Two-way fluid-structure interaction in a gas turbine combustor in limit cycle oscillations". In Proceedings of ASME Turbo Expo 2013, GT2013-94690, San Antonio, Texas, USA, June 3-7.
2. Gövert, S. and Kok, J.B.W., 2013. "Fluid-structure coupling for numerical simulations of a gas turbine combustor". In 20th International Congress on Sound and Vibration (ICSV20), Bangkok, Thailand, July 7-11.

PROJECT LEADERS

JBW Kok

RESEARCH THEME

Mathematical and computational methods for fluid flow analysis

PARTICIPANTS

S Gövert, JBW Kok

COOPERATIONS

CERFACS, RWTH Aachen University, Von Karman Institute, Loughborough University, Turbomeca, Siemens, Barcelona Supercomputing Center, Jülich computational center, Bull, Ansys.

FUNDED

| | |
|---|-------|
| European Union Marie Curie ITN University | - |
| FOM | - |
| STW | - |
| NWO Other | - |
| Industry | - |
| TNO | - |
| GTI | - |
| EU Scholarships | 100 % |

START OF THE PROJECT

2012

INFORMATION

JBW Kok

053 489 2582

j.b.w.kok@utwente.nl

www.thw.ctw.utwente.nl/

LIMOUSINE : LIMIT CYCLES OF PRESSURE OSCILLATIONS IN GAS TURBINE COMBUSTORS

PROJECT LEADERS

JBW Kok

RESEARCH THEME

Mathematical and computational methods for fluid flow analysis

PARTICIPANTS

M Shahi, JBW Kok, ThH van der Meer

COOPERATIONS

Project in cooperation with DLR, CERFACS, Imperial College, Keele University, University of Zaragoza, University of Brno, Siemens Muelheim, Ifa Muenchen, Ansys Abingdon

FUNDED

Partially with European union:
Marie Curie Initial Training network program
University -
FOM -
STW -
NWO Other -
Industry -
TNO -
GTI -
EU 100 %
Scholarships -

START OF THE PROJECT 2011

INFORMATION

JBW Kok
053 489 2582
j.b.w.kok@utwente.nl
www.thw.ctw.utwente.nl

PROJECT AIM

LIMOUSINE aims at the development of numerical tools to predict the chain of events leading to mechanical failure of gas turbine combustors due to limit cycles of low frequency pressure oscillations. Explored is the interaction and the feed back mechanisms between combustion dynamics, acoustics, aerodynamics and structural vibration. Essential is that not only the operating points with linear instability are identified. But also the nonlinear mechanisms leading to amplitude saturation.

PROGRESS

The project task of M.Shahi involves numerical simulations of combustion instabilities in a laboratory scale combustor (both self-excited and induced oscillations). In this task PhD fellow is looking for ways to accurately predict the phenomenon. The work consists of modelling the combustor, looking at the pressure oscillations and liner vibration, coupling between the fluid and structure, coupling between the flame and the structure by means of conjugated heat transfer modelling and finally validations based on experimental findings. The work is done very close with the experimentalists to get the desired data sets to validate the models.

DISSERTATIONS

-

SCIENTIFIC PUBLICATIONS

1. Shahi, M., Kok, J. B. W., Pozarlik, A. K., Roman Casado, J. C., and Sponfeldner, T., "Sensitivity of the numerical prediction of flow in the limousine combustor on the chosen mesh and turbulent combustion model," Proc. Proceedings ASME Turbo Expo 2013, GT2013-94328.
2. Shahi, M., Kok, J. B. W., Sponfeldner, T., and Pozarlik, A., 2013, "Thermal and fluid dynamic analysis of partially premixed turbulent combustion driven by thermo acoustic effects," ICSV20, Bangkok, Thailand.
3. Filosa, A., Tomasello Andrea, Shahi Mina, Noll Berthold, Kok Jim, Aigner Manfred. 2013. numerical studies of unsteady heat transfer with thermoacustics oscillations. in 20th International Congress on Sound & Vibration. Bangkok, Thailand.

LIMOUSINE : LIMIT CYCLES OF PRESSURE OSCILLATIONS IN GAS TURBINE COMBUSTORS

PROJECT AIM

LIMOUSINE aims at the development of numerical tools to predict the chain of events leading to mechanical failure of gas turbine combustors due to limit cycles of low frequency pressure oscillations. Explored is the interaction and the feed back mechanism between combustion dynamics, acoustics, aerodynamics and structural vibration. Essential is that not only the operating points with linear instability are identified, but also the nonlinear mechanisms leading to amplitude saturation.

PROGRESS

In the project European wide 17 PhD students are active, coordinated by the University of Twente. At the UT 5 PhD students and are employed in the area of fluid mechanics, structural vibration and mechanical failure. Key element in the project task of M.Kapucu is the UT elevated pressure (1-5 bar) 100kW/bar, combustor that is operated with preheated air. Target is to bring the combustor in limit cycle pressure oscillation and investigate the saturated amplitude behavior. The acoustic end condition of the combustor has been changed to by highly reflective, also at low frequencies. The combustor showed limit cycle oscillations of combustion and pressure of high amplitude. These were compared with the numerical predictions on basis of the network model with a linear flame transfer function. By means of measurements the nonlinearity of the transfer function was explored and a flame describing function established for certain operating conditions. The describing function showed good comparison with numerical predictions by means of CFD.

DISSERTATIONS

-

SCIENTIFIC PUBLICATIONS

-

PROJECT LEADERS

JBW Kok

RESEARCH THEME

Complex dynamics of fluids

PARTICIPANTS

M Kapucu, JBW Kok, ThH van der Meer

COOPERATIONS

Project in cooperation with DLR, CERFACS, Imperial College, Keele University, University of Zaragoza, University of Brno, Siemens Muelheim, Ifra Muenchen, Ansys Abingdon

FUNDED

European Union: Marie Curie ITN program

| | |
|--------------|-------|
| University | - |
| FOM | - |
| STW | - |
| NWO Other | - |
| Industry | - |
| TNO | - |
| GTI | - |
| EU | 100 % |
| Scholarships | - |

START OF THE PROJECT

2008

INFORMATION

JBW Kok

053 489 2582

j.b.w.kok@utwente.nl

www.thw.ctw.utwente.nl

COPA-GT (COUPLED PARALLEL SIMULATION OF GAS TURBINES) SPRAY COMBUSTION

PROJECT LEADERS

JBW Kok

RESEARCH THEME

Mathematical and computational methods for fluid flow analysis

PARTICIPANTS

V Fratalocchi, JBW Kok

COOPERATIONS

CERFACS, RWTH Aachen University, Von Karman Institute, Loughborough University, Turbomeca, Siemens, Barcelona Supercomputing Center, Jülich computational center, Bull, Ansys.

FUNDED

| | |
|--------------------------------|-------|
| European Union Marie Curie ITN | |
| University | - |
| FOM | - |
| STW | - |
| NWO Other | - |
| Industry | - |
| TNO | - |
| GTI | - |
| EU | 100 % |
| Scholarships | - |

START OF THE PROJECT

2012

INFORMATION

JBW Kok

053 489 2582

j.b.w.kok@utwente.nl

PROJECT AIM

Until now, gas turbines have been designed following individual pathways for each component and each physical phenomenon. Nevertheless, the behavior of the individual components can be very different from their behavior when mounted together in an engine. To overcome this disadvantage, the numerical simulation of the entire engine with all physics involved is a key element for scientific progress and innovation. Developing numerical tools and methodologies to simulate the entire gas turbine with multiple physical effects is a new challenge and the overall scientific objective of the COPA-GT project. In this task of the project numerical models are developed for spray evolution, evaporation, mixing and turbulent combustion. Targeted is transient behaviour of spray combustion and coupling to acoustics. The models are optimized for large scale parallel computation with embedding in full engine models.

PROGRESS

In the project European wide 13 PhD students and 5 Post Docs work under coordination of CERFACS in Toulouse. At the UT 3 PhD students are active. The project task of Virginia Fratalocchi focuses on large scale parallel modelling of transient behaviour of liquid fuel sprays. The SAS-SST turbulence model, the CFI reaction progress model and a Lagrangian spray model will be implemented in the ALYA compressible FEM fluid simulation code of the Barcelona Super Computing Center. As a start the Lagrangian spray model available in Ansys CFX was tuned for a test on the ethanol spray flame experimental data of Masri. Subsequently numerical simulations were performed with ANSYS on an acoustically forced spray flame. This revealed considerable speed up of the combustion rate by the acoustics.

DISSERTATIONS

-

SCIENTIFIC PUBLICATIONS

1. Fratalocchi, V. Kok, J.B.W., dynamics of a partially premixed prevaporized ethanol flame, proc. 20th Int. Congr. Sound and Vibration, Bangkok 7-11 July 2013, ISBN, 2013.

HEAT TRANSFER TO MICRO- AND NANOSTRUCTURES SURFACES

PROJECT AIM

The aim of the project is to study in depth the effect of carbon nano-fibers deposited on heat transfer surface for heat transfer to/ from a fluid. At first materials will be synthesized in a very controlled manner by growing carbon nano-fibers with in situ measurements of the weight increase and the heat of reaction of the synthesis process. Heat transfer to/from the new materials will be determined experimentally. Structural and morphological effect of the CNFs on heat transfer will be studied and optimal configuration will be derived. A production facility for the synthesis of carbon nano-fibers will be designed and built. Finally the performance of the new materials can be determined at ECN in test rigs of a thermo-acoustic and a thermo-chemical heat pump.

PROGRESS

Synthesis of vertically aligned CNFs was obtained by depositing 10nm Ta + 5nm Fe on silicon chip. Two setup orientation are chosen to measure the structural influence of the VACNFs on heat transfer performance. (1) Micro-channel heat transfer measurement setup was designed and produced to measure the structural influence of CNFs on silicon chip. To accurately quantify the conjugated heat transfer from the heater to the setup, the heat transfer measurement is supported by numerical simulation using Comsol. (2) Impinging jet flow setup was designed and built.

DISSERTATIONS

-

SCIENTIFIC PUBLICATIONS

1. T.J. Taha and T.H. van der Meer, "Influence of CNFs layer morphology on convective heat transfer behavior", 8th World Conference on Experimental Heat Transfer, Fluid Mechanics, and Thermodynamics June 16-20, 2013, Lisbon, Portugal.
2. T.J. Taha, L. Lefferts and T.H. van der Meer, "Convective heat transfer enhancement using Carbon nanofibers (CNFs): influence of amorphous carbon layer on heat transfer performance", Proceedings of the ASME 2013 4th Micro/Nanoscale Heat & Mass Transfer International Conference MNHMT2013 December 11-14, 2013, Hong Kong, China.

PROJECT LEADERS

ThH van der Meer

RESEARCH THEME

Complex dynamics of fluids

PARTICIPANTS

TJ Taha, ThH van der Meer

COOPERATIONS

ECN

FUNDED

EL&I

University -

FOM -

STW -

NWO Other -

Industry 100 %

TNO -

GTI -

EU -

Scholarships -

START OF THE PROJECT

2010

INFORMATION

TJ Taha

053 489 2559

t.j.taha@ctw.utwente.nl

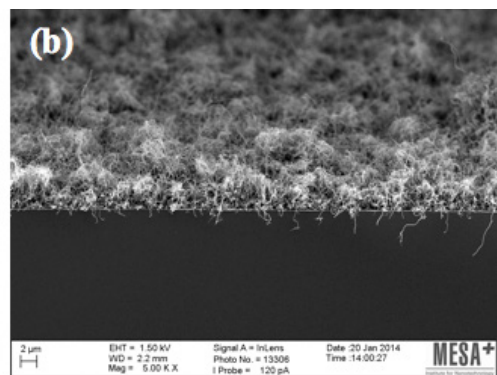
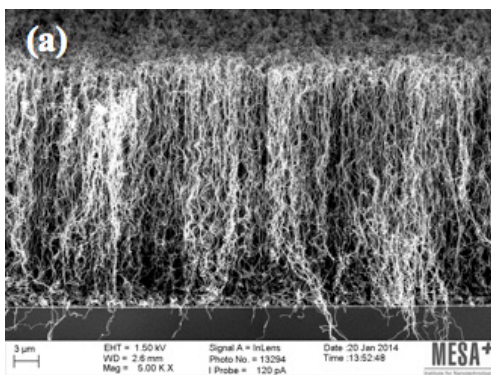

CNFs layer deposition on silicon chip (a) VACNFs layer and (b) spaghetti-shaped CNFs layer

MoST : MULTI-SCALE MODIFICATION OF SWIRLING COMBUSTION FOR OPTIMIZED GAS TURBINES

PROJECT LEADERS

ThH van der Meer

RESEARCH THEME

Complex dynamics of fluids

PARTICIPANTS

AA Verbeek

COOPERATIONS

Dr.ir. RJM Bastiaans, Prof.dr.ir. BJ Geurts

FUNDED

STW, Electrabel Nederland,

Laborelec, TTS/Ansaldo

University -

FOM -

STW 90 %

NWO Other -

Industry 10 %

TNO -

GTI -

EU -

Scholarships -

START OF THE PROJECT

2010

INFORMATION

ThH van der Meer

053 489 2562

t.h.vandermeer@ctw.utwente.nl

PROJECT AIM

The idea of this project is to optimize low swirl burners by adding resonant mixing perturbations. To that end both practical and fundamental research is needed. Physical experiments are crucial to find out a priori the resonant regimes in actual combustors under realistic conditions, in which the low swirl stabilization concept works with good specifications. The experiments will provide data for validation of the findings of the numerical simulations. Numerical simulation by means of DNS and LES, is an essential tool to understand the complex flame dynamics.

PROGRESS

In the past year the research on combustion in combination with fractal grid turbulence has been continued. The increase of turbulent flame speed by using fractal grids as turbulence generators, as has been observed for low-swirl flames, has been investigated in more detail in an academic flame, i.e., V-flame. Here, several grid parameters are investigated to determine their effect on the turbulence and the combustion. It can be concluded that the both fractal 'cross' and 'square' grids efficiently enhance turbulence levels. The increase in turbulent flame speed seems to be mainly dependent on the increase in u' . Other properties of the turbulence are of minor importance for the combustion rate. Furthermore, the active grid generated turbulence applied to a low-swirl burner has been investigated. However, no significant beneficial effect was observed. Besides just described research, the focus was on writing journal publications and the thesis.

DISSERTATIONS

-

SCIENTIFIC PUBLICATIONS

1. Verbeek, A.A. and Pos, R.C. and Stoffels, G.G.M. and Geurts, B.J. and Meer, Th.H. van der (2013) A compact active grid for stirring pipe flow. Experiments in fluids, 54 (1594). ISSN 0723-4864.
2. Verbeek, A.A. and Jansen, W. and Stoffels, G.G.M. and Meer, T.H. van der (2013) Improved flame front curvature measurements for noisy OH-LIF images. In: 8th World Conferences on Experimental Heat Transfer, Fluid Mechanics and Thermodynamics, ExHFT-8, 2013-06-16 - 2013-06-20, Lisbon.

ULRICO : ULTRA RICH COMBUSTION OF HYDROCARBONS AND SOOT FORMATION

PROJECT AIM

This project generates knowledge needed in the design and operation of ultra clean, efficient and reliable natural gas partial combustion systems to produce syngas. Computational fluid dynamics modeling is applied to predict fuel rich turbulent combustion at elevated pressure. The modeling involves prediction of major and minor chemical species, radiative heat loss and soot precursor species. These are linked to a soot formation and transport model for particle size distribution. Multiple combustion regimes are explored. The CFD model is validated by 6 bar/300 kW laboratory tests, including gas composition, soot particle size, nature and number density.

PROGRESS

A MILD-combustor for ultra rich combustion of natural gas has been designed and manufactured. The designed combustor was numerically simulated and analyzed with CHEMKIN PSR and ANSYS CFX. The simulations show that the formation of acetylene, the most important soot precursor, was reduced and that the output of syngas was improved. Experiments with a premixed swirled combustor were performed. The gas composition and soot particle size distribution were measured for different operating conditions. The soot particle size distribution was parameterized in terms of 2 control scalars and used for improvement of the custom soot formation model.

DISSERTATIONS

-

SCIENTIFIC PUBLICATIONS

-

PROJECT LEADERS

JBW Kok

RESEARCH THEME

Mathematical and computational methods for fluid flow analysis

PARTICIPANTS

MHF Woolderink, JBW Kok, ThH van der Meer

COOPERATIONS

Shell Global Solutions, Amsterdam.
Aalborg Industries, Nijmegen.
Automotive Technology Centre, Eindhoven. DAF Trucks, Eindhoven.
ANSYS UK, Abingdon, UK.

FUNDED

| | |
|---|------|
| STW, Shell Global Solutions Amsterdam, ANSYS UK | |
| University | - |
| FOM | - |
| STW | 75 % |
| NWO Other | - |
| Industry | 25 % |
| TNO | - |
| GTI | - |
| EU | - |
| Scholarships | - |

START OF THE PROJECT

2009

INFORMATION

JBW Kok
053 489 2582
j.b.w.kok@utwente.nl
www.utwente.nl/ctw/thw



Prof.dr.rer.nat. S Luding

The Multi Scale Mechanics group (MSM) is part of the cluster Energy and Flow and Engineering in the Faculty of Engineering Technology at the University of Twente, as well as member of the research institute MESA+. The group studies the static and dynamic properties of dry and wet granular materials, as well as fluids and solids in general.

Examples include segregation versus mixing; sticky powders; wave-propagation in disordered media; solid concrete; avalanche flows of grains, snow or soil; composite and self-healing materials. A wide range of length and time scales characterizes the relevant physical processes in these systems. At the microscopic level, the deformation behavior of the granule/atom/molecule with contact/interaction physics on the nano-meter scale determines the dynamics and statics of the particles. The mesoscopic level sees the collective motions of the individual granules involving e.g. shear localization and wave-propagation. Finally, on the macroscopic level, a granular material behaves as a fluid with complex flow behavior involving anisotropy. At each length scale, the question arises how the mechanics at that level is determined by the properties of the underlying level, and how, in turn, the current level affects the previous and the next levels.

Theory and experiments, supported by advanced numerical simulations, are aimed at understanding the various, multiple scales/levels and their intricate couplings. Micro-Macro theory is one way to predict and describe this hierarchy. By combining numerical simulations with theory and experiments, the Multi Scale Mechanics group is developing a comprehensive understanding of the properties of granular materials, fluids and solids. The group is also interested in mesoscale simulations (on intermediate level) of particles with attractive interactions, to study aggregation of self-assembly of patchy colloidal particles and proteins on the macromolecular scale, or to model asphalt on the stone-bitumen scale. Mesoscopic models use the small-scale information to formulate effective contact laws and allow thus to simulate much larger systems than possible with (too) detailed micro-models.

Besides improving our fundamental understanding of fluids and solids, the results find applications in the improvement of industrial processing procedures for granular matter, as well as contributing to the design of advanced materials, processes and equipment.

MODELING OF LONG-RANGE INTERACTION FORCES AND CLUSTERING PHASE DIAGRAM

PROJECT AIM

The objective of this Ph.D. project is to understand the interactions between particles in granular systems from discrete element simulations. The aim is to model long range attractive / repulsive interactions in homogeneous systems, and segregation of particles by size in granular flows. The results will be compared with theoretical and experimental work.

PROGRESS

In the last year, we finalized the study of the clustering phase diagram for granules with long-range interactions. We found that the combination of dissipation and long-range attraction (or repulsion) results in a rich phase behavior, determined by the ratio of dissipative and long-range forces. The figure shows the evolution for two systems with distinct dissipation strengths: in the first row, the dissipation is small and the emerging clusters are of limited size; in the second row, the dissipation is large and extensive clusters are formed. Similar clustering behavior can be seen in various processes, ranging from coating of nano-particles, nano-particle agglomeration and even to interstellar gasses.

DISSERTATIONS

1. Sebastian Gonzalez Briones, April 2013 (UTwente). An Investigation into Clustering and Segregation in Granular Materials.

SCIENTIFIC PUBLICATIONS

1. A. R. Thornton, D. Krijgsman, R. Fransen, S. Gonzalez, A. te Voortwis, S. Luding, O. Bokhove, T. Weinhart, A review of recent work on the Discrete Particle Method at the University of Twente: An introduction to the open-source package MercuryDPM (Review), DEM-6 Conference Proceedings (2013).
2. A. R. Thornton, D. Krijgsman, R. Fransen, S. Gonzalez, D. Tunuguntla, A. te Voortwis, S. Luding, O. Bokhove, T. Weinhart, MercuryDPM: Fast particle simulations in complex geometries, Newsletter EnginSoft Year 10(1) 48-53 (2013).

PROJECT LEADERS

S Luding

RESEARCH THEME

Complex structures of fluids

PARTICIPANTS

S Gonzalez, A Thornton, S Luding

COOPERATIONS

-

FUNDED

FOM

University -

FOM 100 %

STW -

NWO Other -

Industry -

TNO -

GTI -

EU -

Scholarships -

START OF THE PROJECT

2009

INFORMATION

S Gonzalez

053 489 3371

s.luding@utwente.nl

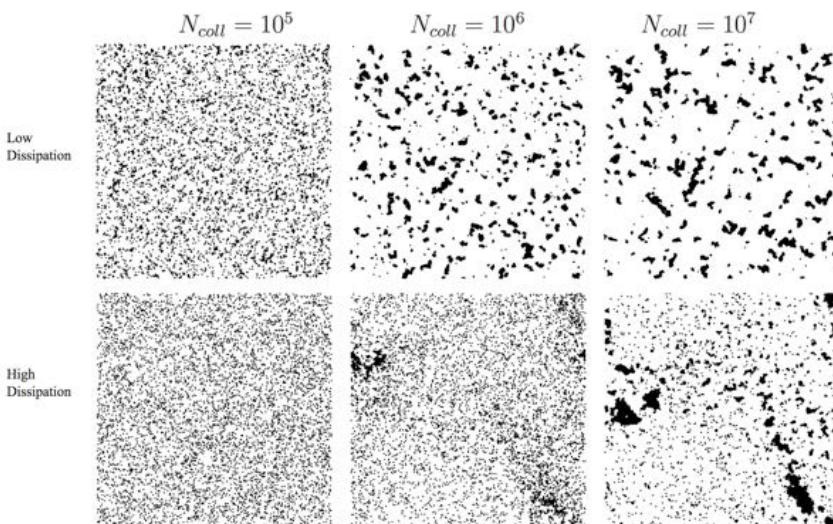

PROJECT LEADERS

S Luding

RESEARCH THEME

Complex dynamics of fluids

PARTICIPANTS

RM Hartkamp, A Ghosh, S Luding

COOPERATIONS

B.D. Todd (Swinburne University of Technology), P.J. Davis (Royal Melbourne Institute of Technology), S. Bernardi (University of Queensland), D. Searles (University of Queensland), A.P. Markesteijn (Cambridge University), J. Westerweel (Delft University of Technology). T.A. Hunt (UTwente)

FUNDED

| | |
|-----------------------------|------|
| MicroNed, UT & NWO-STW VICI | |
| University | 50 % |
| FOM | - |
| STW | - |
| NWO Other | 50 % |
| Industry | - |
| TNO | - |
| GTI | - |
| EU | - |
| Scholarships | - |

START OF THE PROJECT

2006

INFORMATION

S Luding
053 489 4212
s.luding@utwente.nl

PROJECT AIM

During the past few years molecular dynamics has been a widely applied tool to simulate fluids confined in micro/nano geometries. What makes interfacial fluids fundamentally different from bulk fluids is the fact that their density varies considerably over microscopic distances. Fluids confined by solid boundaries to very narrow spaces are strongly inhomogeneous. The goal of the present project is to study the stresses and shear viscosity of such fluids, and to investigate the effects of walls on the local properties of the fluid, both at rest and under a driving force.

PROGRESS

In this project we simulate planar Poiseuille flow of a Lennard-Jones fluid in channels of various widths in the nanoscale regime. Atoms arrange in layers parallel to the channel walls, such that the density of the fluid is an oscillating function of the position. Consequently, other quantities also vary with position, since they are related to the density. We obtain average stress and strain rate profiles across the channel. Anisotropy in stress is found near the walls; the influence of various parameters on the layering and anisotropy are studied. Understanding and quantifying the non-Newtonian behavior is a first step towards deriving a constitutive model that governs the behavior of a strongly confined fluid. A constitutive framework is proposed to quantify the relation between stress tensor and strain rate, temperature, density and other profiles in homogeneous and inhomogeneous fluids. Non-equilibrium molecular dynamics simulations of an atomic fluid under shear flow, planar elongational flow and a combination of shear and elongational flow are unified consistently with a tensorial model over a wide range of strain rates. A non-Newtonian model is presented that predicts the pressure tensor for a bulk fluid under a homogeneous planar flow field, providing a quantitative description of the strain-thinning viscosity, pressure dilatancy, deviatoric viscoelastic lagging and out-of-flow-plane stress anisotropy. The non-equilibrium stress tensor is completely described through these four quantities and can be calculated as a function of the equilibrium material constants and the velocity gradient. This constitutive framework in terms of invariants of the stress tensor departs from the conventional description that deals with an orientation-dependent description of shear stresses and normal stresses. The present model makes it possible to predict the full pressure tensor for a simple fluid under various types of flow without having to produce these flow types explicitly in simulation or experiment.

DISSERTATIONS

1. Remco Hartkamp. May, 2013 (UTwente). MD study of non-Newtonian flow of simple fluids in confined & unconfined geometries.

SCIENTIFIC PUBLICATIONS

1. T. Weinhart, R. Hartkamp, A. R. Thornton, and S. Luding, Coarse-grained local and objective continuum description of 3D granular flows down an inclined surface, [Phys. Fluids 25, 070605, 2013].
2. R. H. Hartkamp, B. Todd, and S. Luding, A constitutive framework for the non-Newtonian pressure tensor of a simple fluid under planar flows, [J. Chem. Phys. 138, 244508, 2013].

PROJECT AIM

The primary goal of the project is to investigate flow of dry granular materials over inclined planes (chutes), and the resulting segregation for granular materials polydisperse in size and density. For this purpose, we are developing a macro-scale continuum Discontinuous Galerkin Finite Element Method (DGFEM) granular flow model, which is coupled to a micro-scale Discrete Particle Model (DPM). This project is run in close collaboration with an industrial partner, Tata Steel.

PROGRESS

We proposed an extension of continuum models based on mixture theory that enables application to bi-disperse flows with particles varying in density and size. Our model incorporates both a shear rate dependent drag and a recently proposed explicit formula on the pressure distribution among particles of different species, which is a key element of kinetic sieving models based on mixture theory. The resulting model is used to predict the size and density ranges for which mixtures segregate. The model also predicts very weak segregation, which is benchmarked using discrete element simulations (DEMs). Furthermore, a highly effective coarse-graining tool is being developed to extract the macroscopic field variables, appearing in continuum-mechanical models, from microscopic DPM simulations. By this mapping procedure, DPM can be used to calibrate continuum models.

DISSERTATIONS

-

SCIENTIFIC PUBLICATIONS

1. A. Thornton, D. Krijgsman, R. Fransen, S. Gonzalez, D. Tunuguntla, A. te Voortwis, S. Luding, O. Bokhove and T. Weinhart, Mercury-DPM: Fast particle simulations in complex geometries, EnginSoft Newsletter 10, 48-53 (2013).
2. T. Weinhart, S. Luding and A.R. Thornton, From discrete particles to continuum fields in mixtures, AIP Conf. Proc. 1542, 1202-1205 (2013).
3. A.R. Thornton, T. Weinhart, V. Ogarko and S. Luding, Multi-scale modeling of multi-component granular materials, Comput. Meth. Mater. Sci. 13, 197-212 (2013).

PROJECT LEADERS

AR Thornton, O Bokhove, S Luding (CTW, UT), JJW van der Vegt (EWI, UT)

RESEARCH THEME

Mathematical and computational methods for fluid flow analysis

PARTICIPANTS

DR Tunuguntla, T Weinhart

COOPERATIONS

Tata Steel

FUNDED

| | |
|--------------|-------|
| STW | |
| University | - |
| FOM | - |
| STW | 100 % |
| NWO Other | - |
| Industry | - |
| TNO | - |
| GTI | - |
| EU | - |
| Scholarships | - |

START OF THE PROJECT

2011

INFORMATION

DR Tunuguntla
053 489 3373
D.R.Tunuguntla@utwente.nl

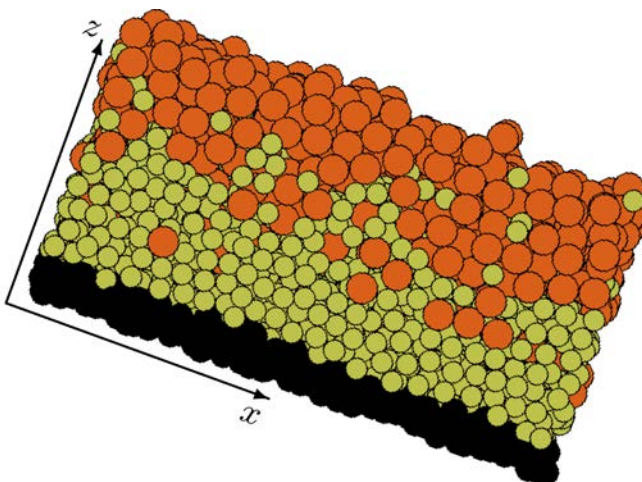

A bi-disperse mixture flowing over a rough inclined plane

BRIDGING THE GAP BETWEEN PARTICULATE SYSTEMS AND CONTINUUM THEORY

PROJECT LEADERS

S Luding

RESEARCH THEME

Complex dynamics of fluids

PARTICIPANTS

N Rivas, A Thornton, D van der Meer
(PoF, UT)

COOPERATIONS

-

FUNDED

| | |
|--------------|-------|
| NWO-STW VICI | |
| University | - |
| FOM | - |
| STW | - |
| NWO Other | 100 % |
| Industry | - |
| TNO | - |
| GTI | - |
| EU | - |
| Scholarships | - |

START OF THE PROJECT

2011

INFORMATION

N Rivas
06 468 01577
N.A.Rivas@utwente.nl
www2.msm.ctw.utwente.nl/nrivas/

PROJECT AIM

We apply and compare microscopic and macroscopic numerical and theoretical models of a driven granular system, consisting of a vertically shaken narrow box filled with grains. The studied system presents many different inhomogeneous stable states as a function of the energy injection and grain properties and number. We focus on the transitions between the different states and study the influence of finite particle size and low particle number s , which may lead to a better general understanding of the out-of-equilibrium statistical physics behind driven complex granular systems.

PROGRESS

Last year was devoted to four main topics. First, we continued the study of the low-frequency oscillations discovered in the shallow vibrated geometry, and finished a publication on the subject. Second, the study of binary systems of particles with different size and/or mass was carried further, showing remarkable agreement with ongoing experiments. A publication on the subject was submitted. Next, we used Positron Emission Particle Tracking to explore the low-frequency oscillations observed in our simulations, in collaboration with the University of Birmingham. The experiments were successful in reproducing the phenomena, and our proposed theory showed a remarkable agreement with the data. Finally, further progress was made to solve the continuum granular hydrodynamic equations, by developing the necessary software and performing the first numerical experiments.

DISSERTATIONS

1. "Low-frequency oscillations in vertically vibrated granular beds", Physics of glassy and granular materials, Yukawa institute for theoretical physics, Kyoto, July 2013.

SCIENTIFIC PUBLICATIONS

1. N. Rivas, S. Luding, A. R. Thornton, Low-frequency oscillations in narrow vibrated granular systems, *New J. Phys.* 15, 113043 (2013).
2. C.R.K. Windows-Yule, N. Rivas and D.J. Parker, Thermal convection and temperature inhomogeneity in a vibrofluidized granular bed: the influence of sidewall dissipation, *Phys. Rev. Lett.* 111, 038001 (2013).

BRIDGING THE GAP BETWEEN PARTICULATE SYSTEMS AND CONTINUUM THEORY

PROJECT AIM

Modern discrete particle-based models describe the particles in detail, but are of limited value for studying industrial processes and natural phenomena since too many particles are involved. Continuum methods, on the other hand, are readily applied in engineering applications. However, these methods rely on empirical constitutive laws with phenomenological parameters that disregard both the discrete nature of particles and the micro-structure. Micro-macro transition methods are being developed to combine the advantages of discrete and continuum models and thus bridge the gap between particulate systems and continuum theory.

PROGRESS

A novel local constitutive model has been developed, based on observations from discrete element simulations, for small-scale deformations of a quasi steady bi-axial geometry. The nonlinear evolution equations for both shear stress and anisotropy during deviatoric (shear) deformations requires only four material parameters and accounts for history dependence. Several simulations were performed to test the model's accuracy for various deformation modes. Future work will include extending the model to generic 3D systems and implementing it in a finite element method. The objective is to predict stresses and strains in macroscale applications, taking into account the evolution of the microscopic material structure.

DISSERTATIONS

-

SCIENTIFIC PUBLICATIONS

1. A. Thornton, D. Krijgsman, R. Fransen, S. Gonzalez Briones, D. Tunuguntla, A. te Voortwis, S. Luding, O. Bokhove and T. Weinhart, MercuryDPM: Fast particle simulations in complex geometries, EnginSoft Newsletter 10, 48-53 (2013).
2. D. Krijgsman and S. Luding, 2D cyclic pure shear of granular materials, simulations and model, Proc. 7th Int. Conf. Micromech. Granul. Media, Sydney, AIP Publishing, 1226-1229 (2013).
3. A.R. Thornton, D. Krijgsman, A. te Voortwis, V. Ogarko, S. Luding, R. Fransen, J.S. Gonzalez Briones, O. Bokhove, O.I. Imole and T. Weinhart, A review of recent work on the Discrete Particle Method at the University of Twente: An introduction to the open-source package MercuryDPM. 6th International Conference on Discrete Element Methods, Proceedings (2013).

PROJECTLEADERS

S Luding, V Magnanimo

RESEARCHTHEME

Complex structures of fluids

PARTICIPANTS

D Krijgsman

COOPERATIONS

-

FUNDED

| | |
|--------------|-------|
| STW-NWO | |
| University | - |
| FOM | - |
| STW | - |
| NWO Other | 100 % |
| Industry | - |
| TNO | - |
| GTI | - |
| EU | - |
| Scholarships | - |

START OF THE PROJECT

2010

INFORMATION

D Krijgsman

053 489 4732

d.krijgsman@utwente.nl

PROJECT LEADERS

S Luding, M Ramioli

RESEARCH THEME

Mathematical and computational methods for fluid flow analysis

PARTICIPANTS

M Robinson

COOPERATIONS

Nestlé Research Center

FUNDED

Marie Curie Initial Training Network

PARDEM

University -

FOM -

STW -

NWO Other -

Industry -

TNO -

GTI -

EU 100 %

Scholarships -

START OF THE PROJECT

2010

INFORMATION

S Luding

s.luding@utwente.nl

PROJECT AIM

A validated CFD-DEM simulation is developed and used to analyse the decompaction and dispersion of the powder bed by a water jet. For a wet particle bed, the challenges will include the correct modelling of the liquid-particle coupling over a wide range of porosities. For the dry particle bed there will also be a wide range of particle saturation (relative ratio of interstitial liquid and air). Goal is to determine which operating conditions giving rise to particular dynamical regimes and to understand the temporal and spatial distribution of the particles in the cell.

PROGRESS

A two-way coupled SPH-DEM simulation tool has been developed, based on the locally averaged Navier Stokes equations presented by Anderson and Jackson (1967). This has been applied to single and multiple particle sedimentation test problems. Some initial simulations of a water jet impacting on a granular bed have been performed. The relative strengths of the various drag terms (e.g. Added mass force, history force, lift force etc) have been compared using a simple analytical model and the same physical parameters as the experimental results. Quantitative comparison to experiments on powder dispersion are in progress, see the figure below.

DISSERTATIONS

-

SCIENTIFIC PUBLICATIONS

1. M. Robinson, S. Luding, and M. Ramioli, Fluid-particle flow modelling and validation using two-way coupled, mesoscale SPH-DEM, [Int. J. Multiphase Flow 59, 121-134, 2013], [arXiv:1301.0752] (14 pages).
2. M. Robinson, S. Luding, and M. Ramioli, Grain sedimentation with SPH-DEM and its validation, in: Powders and Grains 2013, A. Yu, K. Dong, R. Yang, and S. Luding (Eds.), [AIP Conf. Procs. #1542 (2013)], pp. 1079-1082.
3. M. Robinson, S. Luding, and Marco Ramioli, SPH-DEM simulations of grain dispersion by liquid injection, in: Powders and Grains 2013, A. Yu, K. Dong, R. Yang, and S. Luding (Eds.), [AIP Conf. Procs. #1542 (2013)], pp. 1122-1125.

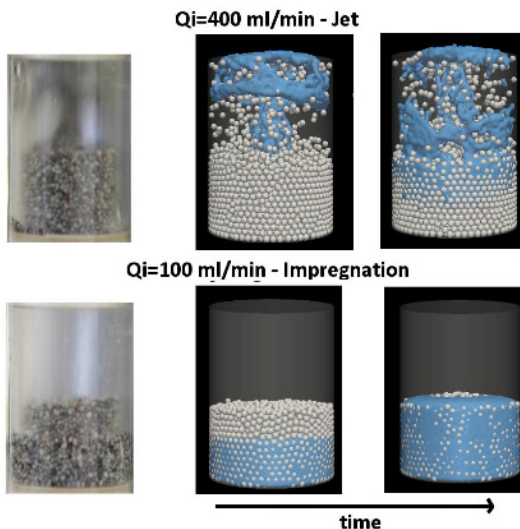

Dispersion of a dry granular bed of poppy seeds by a 1mm central injection hole. Left: Experimental dispersion patterns shortly after liquid injection starts. Center and Right: Three-phase SPH-DEM simulations, two snapshots are shown in order of increasing time. Grains are represented using white spheres and the water free-surface is colored in blue. Top row: A 400 ml/min inlet flow rate generates a jet. Bottom row: A 100 ml/min flow rate induces a bottom-up impregnation.

BRIDGING THE GAP BETWEEN PARTICULATE SYSTEMS AND CONTINUUM THEORY

PROJECT AIM

Granular materials consist of discrete particles. These systems display a broad range of poorly understood phenomena like segregation, structure formation and failure under flow. Generations of scientists and engineers have developed a basic understanding and established practical recipes for the handling and processing of granular systems. In the last 20 years, theoretical physics and computer simulations have made significant contributions by elucidating the mechanisms underlying many phenomena in particulate systems. The goal of this project is to bridge the gap between discrete and continuum concepts and methods.

PROGRESS

Non-affine response of jammed granular assemblies: To understand the non-affine responses of dense granular packings, we study the probability distribution functions (PDFs) of forces and overlaps between granular particles under isotropic (de)compression. We introduced a master equation which well predicts the development of the PDFs under (de)compressions (see figure).

Dynamic heterogeneities in driven granular particles: The complex glassy dynamics of granular particles floating on water has been studied by experiments. We find that the characteristic time and length scales diverge near the jamming density of the particles.

Rheology of cohesive granular particles: We study the rheology of cohesive grains by molecular dynamics simulations. The cohesive forces between the particles drastically change the rheological properties of the systems.

DISSERTATIONS

-

SCIENTIFIC PUBLICATIONS

1. K. Saitoh and H. Hayakawa, Quantitative test of the time dependent Ginzburg-Landau equation for sheared granular flow in two dimensions, Phys. Fluids 25, 070606 (2013).

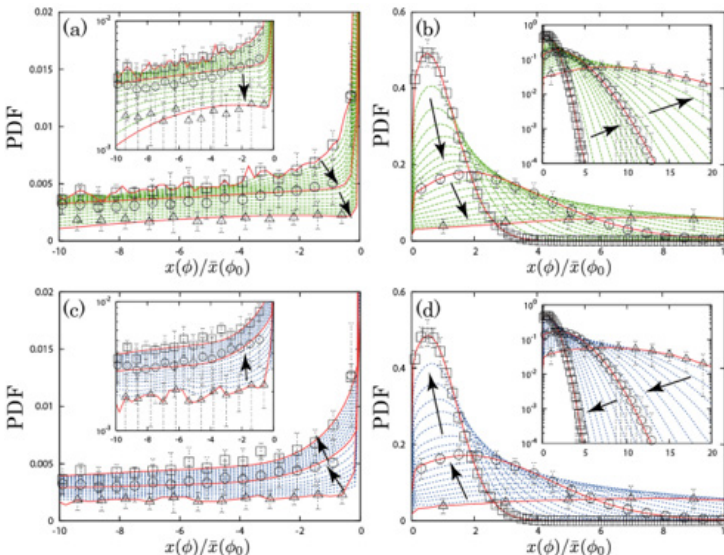

PROJECT LEADERS

S Luding

RESEARCH THEME

Mathematical and computational methods for fluid flow analysis

PARTICIPANTS

Kuniyasu Saitoh

COOPERATIONS

-

FUNDED

VICI-STW

University -

FOM -

STW -

NWO Other 100 %

Industry -

TNO -

GTI -

EU -

Scholarships -

START OF THE PROJECT

2011

INFORMATION

K Saitoh

053 489 5363

k.saitoh@utwente.nl

www2.msm.ctw.utwente.nl/saitohk/

PROJECT LEADERS

S Luding

RESEARCH THEME

Complex dynamics of fluids

PARTICIPANTS

A Singh, V Magnanimo, K Saitoh

COOPERATIONS

-

FUNDED

FOM, NWO

University -

FOM 50 %

STW -

NWO Other 50 %

Industry -

TNO -

GTI -

EU -

Scholarships -

START OF THE PROJECT

2009

INFORMATION

A Singh

053 489 2694

A.Singh@ctw.utwente.nl

PROJECT AIM

To probe the connections between jamming, shear banding and microstructure in numerical simulations of Brownian and non-Brownian systems with various interaction forces, shear rates and stress regimes. Discrete element simulations will be used to study the shear banding in a 'split bottom ring shear cell', where a slow quasi-static deformation leads to wide shear bands being formed away from the side walls.

PROGRESS

Discrete element simulations are used to study the effect of cohesion on shear banding in a split-bottom ring shear cell. For low driving rates the shear bands are found to collapse to a single function. A dimensionless number, the Bond number (Bo), is defined to quantify the intensity of attractive cohesive forces relative to gravity. We find that Bo acts as a critical parameter in the system: the width of the shear band is independent of cohesion for $Bo < 1$, while the shear band gets wider with increasing cohesion for $Bo > 1$. The anisotropy of the force chain network increases with cohesion. Poor mobility of particles due to strong cohesion also leads to heterogeneous structures in both compressive and tensile directions. The microstructure is examined closer with striking insights on the anisotropy of tensile and repulsive forces, see figure.

DISSERTATIONS

-

SCIENTIFIC PUBLICATIONS

1. A. Singh, V. Magnanimo, and S. Luding, Effect of friction and cohesion on anisotropy in quasi-static granular materials under shear, in: Powders and Grains 2013, A. Yu, K. Dong, R. Yang, and S. Luding (Eds.), [AIP Conf. Procs. #1542 (2013)], pp. 682-685

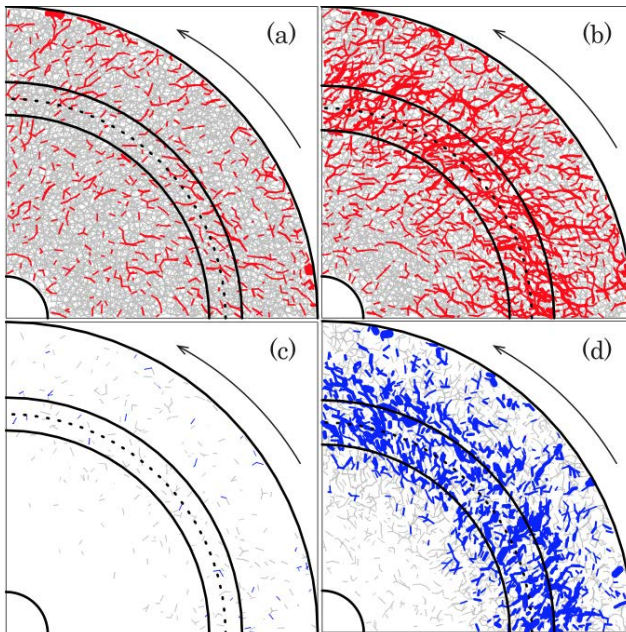

Figure Interparticle forces in the top layer of the bed, for a quarter segment of the ring shear cell, with the shear band region centered on the dotted line. The top two images show particle pairs exerting a repulsive net force, the two bottom images show pairs exerting an attractive net force (grey: below average strength, red/blue: above average strength). Left and right correspond to low and high cohesion, relatively. Note that both the attractive and the repulsive forces increase with increasing cohesion.

MODELING PARTIALLY WET PARTICLE SYSTEMS: MICROSCOPY AND MACROSCOPY

PROJECT AIM

The objective of the project is to develop a description of the flow of partially wet granular materials, based on detailed knowledge of the links between micro-scale and macro-scale material parameters. The main targets of the project are the formulation of suitable constitutive equations for the stress-strain relations of wet granular materials, the deduction from Discrete Element Method (DEM) simulations of the parameters entering these constitutive equations, the validation of the micro-macro transition with data from experiments on wet granular materials, and the development of more efficient macroscopic simulation tools to model large-scale experiments.

PROGRESS

The cylindrical Couette cell, see figure, has proven a convenient system to study the flow behavior of dry granular materials at the microscopic and macroscopic level. In the current project, which has started only recently, the DEM simulations will be extended with an appropriate model of cohesive liquid capillary bridges between the particles, to analyze the microscopic and macroscopic behaviour of partially wet granular materials. In the moment various models from literature are reviewed and compared. The challenge is to understand which microscopic details affect the macroscopic flow behavior, as the shear resistance, the position, and the width of the shearband.

DISSERTATIONS

-

SCIENTIFIC PUBLICATIONS

1. R. Schwarze, A. Gladkyy, F. Uhlig, and S. Luding, Rheology of weakly wetted granular materials - a comparison of experimental and numerical data, *Granular Matter* 15(4), 455-465, 2013.
2. R. Schwarze, A. Gladkyy, and S. Luding, Critical state flow rules for CFD simulations of wet granular flows, in: III International Conference on Particle-based Methods - Fundamentals and Applications PARTICLES 2013, Proceedings of Particle-Based Methods III, M. Bischoff, E. Ramm, E. Onate, R. Owen, and P. Wriggers (Eds.), ISBN: 978-84-941531-8-1, pp. 153-164, 2013.

PROJECT LEADERS

S Luding, T Weinhart

RESEARCH THEME

Mathematical and computational methods for fluid flow analysis

PARTICIPANTS

S Roy

COOPERATIONS

R. Schwarze (TU Freiberg)

S. Turek (TU Dortmund)

A. Gladkyy (TU Freiberg)

A. Ouazzi (TU Dortmund)

S. Mandal (TU Dortmund)

FUNDED

STW, DFG

University -

FOM -

STW 50 %

NWO Other -

Industry 50 %

TNO -

GTI -

EU -

Scholarships -

START OF THE PROJECT

2013

INFORMATION

S Luding

053 489 4212

s.luding@utwente.nl

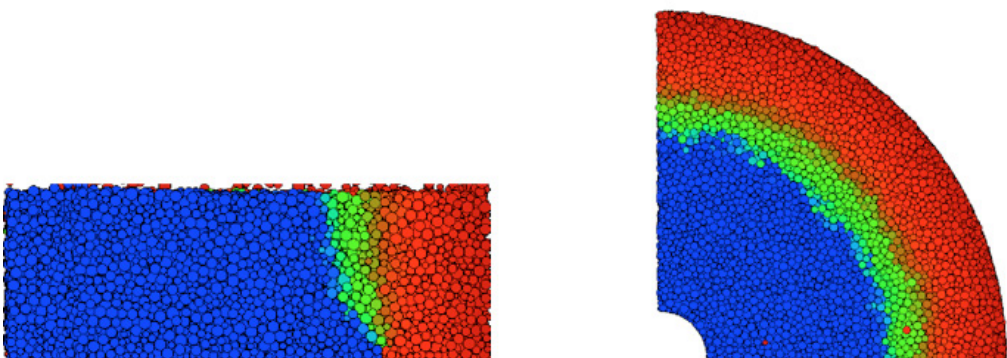

Snapshots (left: cross-section, right: top view) showing the tangential velocities (color coded) of 37000 particles confined between a stationary inner cylinder and a concentric rotating outer cylinder. The shear-band is indicated by green.

PROJECT LEADERS

S Luding

RESEARCH THEME

Complex structures of fluids

PARTICIPANTS

V Ogarko, K Yazdchi, S Srivastava

COOPERATIONS

M. van der Hoef (UT), H. Wachtel (Boehringer Ingelheim), P. Cleary (CSIRO)

FUNDED

| | |
|--------------------|------|
| STW-MUST, Industry | |
| University | - |
| FOM | - |
| STW | 80 % |
| NWO Other | - |
| Industry | 20 % |
| TNO | - |
| GTI | - |
| EU | - |
| Scholarships | - |

START OF THE PROJECT

2008

INFORMATION

V Ogarko
v.ogarko@utwente.nl

PROJECT AIM

Goal of the project is to develop a multi-scale computational method that uses a single hierarchical data-structure as basis – involving also multiple fields. Starting from meso-scope structures (particles or domains) a grid is constructed on a hierarchical, tree-based data structure. The hierarchical approach allows for micro-macro transition, coupling of different fields, and coarsening or refinement – where possible or needed, respectively.

PROGRESS

The equilibrium equation of state of a fluid mixture of polydisperse hard spheres is well described by considering only the first three moments of the size distribution function. Consequently, the thermodynamic properties of a polydisperse fluid can be reproduced by a well-chosen bidisperse fluid. In this study we ask the question: How many moments are needed to predict the pressure and the jamming density of poly-disperse mixtures in compressed non-equilibrium glassy states? We find that five moments suffice to describe the properties of polydisperse mixtures for all densities, including glassy, non-equilibrium states and the maximal jamming density. Hence, this behavior can be reproduced by a well-chosen tridisperse system. The volume fraction of rattlers is also well predicted, and the system's behavior is shown to be controlled by the non-rattlers.

DISSERTATIONS

-

SCIENTIFIC PUBLICATIONS

1. V. Ogarko and S. Luding, Equation of state and jamming density for equivalent bi- and polydisperse, smooth, hard sphere systems, *J. Chem. Phys.* 136, 124508, 2012.
2. V. Ogarko, and S. Luding, A fast multilevel algorithm for contact detection of arbitrarily polydisperse objects, *Comp. Phys. Communications* 183(4), 931-936, 2012.

A polydisperse system with uniform volume radii distribution (left) and the equivalent tridisperse system (right). The 8192 particles are colored by size. For details see Ref. [1].

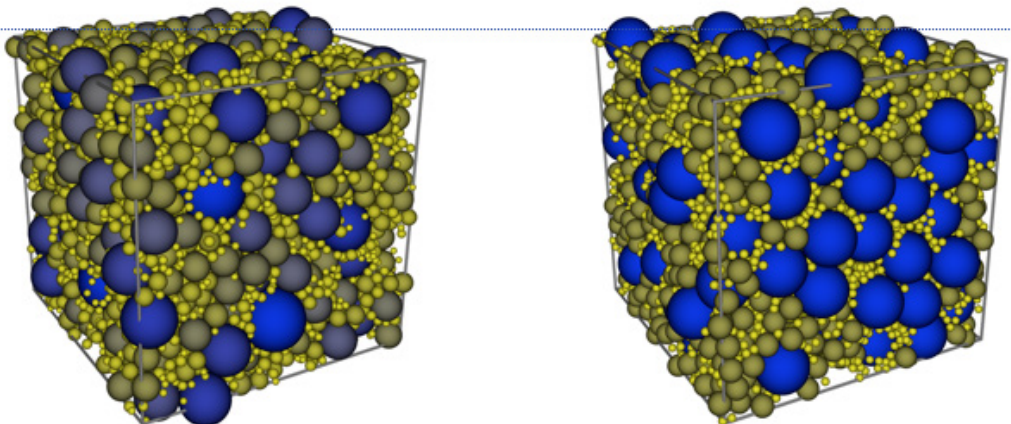

SINTERING OF GRANULES – THE DEPENDENCE OF CONTACTS ON PRESSURE, TEMPERATURE AND TIME

PROJECT AIM

The goal of this project is to model particles in contact, in particular for particles that melt and sinter when heated and thereby lose their identity. Temperature and pressure dependent contact models are being developed in parallel to contact-measurements in the group of dr. Kappl (Mainz). The resulting many- particle simulation model will be experimentally validated against bulk experiments by the group of prof. Tomas (Magdeburg). This model will be used for the micro-macro transition: the microscopic contact mechanics between particle is used to deduce constitutive relations for the macroscopic description of sintered materials.

PROGRESS

The rolling, sliding and torsion properties of silica microspheres are being investigated in collaboration with dr. Staedler (Siegen), see Fig 1. Contact modeling and simulations of sintered material are in progress in collaboration with M. Kappl (Mainz), where sintering of μm -sized particles is studied using Atomic Force Microscopy. A local and objective description of the stress tensor under shear was developed both for molecular and granular flows. The method was applied to describe segregation mechanisms in bidispersed granular flows. The micro-macro transition methods described above are implemented in MercuryDPM, an in-house developed open-source code for particle simulations. The easily understandable code of MercuryDPM is very versatile, to promote the transfer of scientific knowledge via advanced numerical codes, algorithms and tools to users in industry and academia.

DISSERTATIONS

-

SCIENTIFIC PUBLICATIONS

1. T. Weinhart, R. Hartkamp, A.R. Thornton and S. Luding, Coarse-grained local and objective continuum description of three-dimensional granular flows down an inclined surface, *Phys. Fluids*, 25, 070605 (2013).
2. T. Weinhart, S. Luding and A.R. Thornton, From discrete particles to continuum fields in mixtures, in *Powders and Grains*, A. Yu, et al. (Eds.), p. 1202-1205 (2013).
3. A. Thornton, D. Krijgsman, R. Fransen, S. Gonzalez, D. Tunuguntla, A. te Voortwis, S. Luding, O. Bokhove and T. Weinhart, Mercury-DPM: Fast particle simulations in complex geometries, *EnginSoft Newsletter* 10, 48-53 (2013).
4. A.R. Thornton, T. Weinhart, V. Ogarko and S. Luding, Multi-scale modeling of multi-component granular materials, *Comput. Meth. Mater. Sci.* 13, 197-212 (2013).

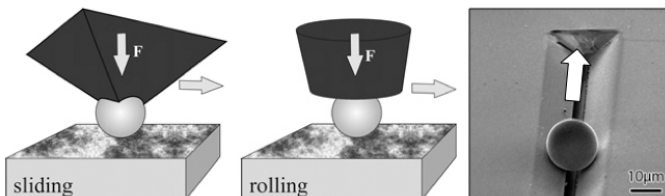

PROJECTLEADERS

S Luding

RESEARCHTHEME

Mathematical and computational methods for fluid flow analysis

PARTICIPANTS

T Weinhart

COOPERATIONS

M Kappl (MPIP Mainz), J Tomas (Uni Magdeburg), T Staedler (Uni Siegen)

FUNDED

DFG SPP PiKo

University -

FOM -

STW -

NWO Other -

Industry 100 %

TNO -

GTI -

EU -

Scholarships -

START OF THE PROJECT

2011

INFORMATION

S Luding

053 489 4212

s.luding@utwente.nl

Three modes of motion can be measured on micron-sized particles in the nano-indenter setup: pure sliding (left), pure rolling (center) and combined rolling-torsion (right); the latter uses the novel rail setup

PROJECT LEADERS

S Luding, H Steeb, J Harting

RESEARCH THEME

Complex dynamics of fluids

PARTICIPANTS

I Guven

COOPERATIONS

Shell-FOM IPP

FUNDED

Shell-FOM IPP

University -

FOM -

STW -

NWO Other -

Industry 100 %

TNO -

GTI -

EU -

Scholarships -

START OF THE PROJECT

2010

INFORMATION

H Steeb

+49(0)234 32 23080

holger.steeb@rub.de

S Luding

053 489 4212

s.luding@utwente.nl

PROJECT AIM

The project aims to investigate the behavior of oil-water mixtures in porous media by means of combined electromagnetic-acoustic wave propagation.

The emulsion will be stabilized by amphiphilic ferro-magnetic nano-particles.

The goals are to establish whether these particles are a suitable alternative to current enhanced oil recovery techniques, and whether pulsed electromagnetic fields can be used to guide the particles to regions of interest.

PROGRESS

In the first year, porous probe materials were produced by sintering glass bead samples with various particle diameters and degrees of dispersion. The second year of the PhD project was focused on the elaborate μ CT (x-ray micro-tomography) analysis of the samples in terms of their porosity, (geometrical) tortuosity, and particle size distribution. A clear dependence on the height is visible in the data, see figure, which is attributed to the influence of gravity during the sintering process. Based on the voxel data lattice, Boltzmann 3D simulations for differently sized cubes were carried out to numerically determine their permeabilities, in parallel with laboratory measurements on these samples. We confirmed that the numerical and experimental values of the permeability are of the same order of magnitude, varying between the samples from 10⁻⁹ to 10⁻¹¹ m².

DISSERTATIONS

-

SCIENTIFIC PUBLICATIONS

1. I. Gueven, S. Luding and H. Steeb, Hydraulic and acoustic investigation of sintered glass beads, AIP Conf. Proc. #1542, 581-584 (2013).
2. K. Yazdchi and S. Luding, Upscaling and microstructural analysis of the flow-structure relation perpendicular to random, parallel fiber arrays, Chem. Eng. Sci. 98, 173-185 (2013).

Spatial distributions of permeability (left), porosity (center) and geometrical tortuosity (right) for a porous sintered glass bead sample with bead diameters between 0.4 and 0.6 mm.

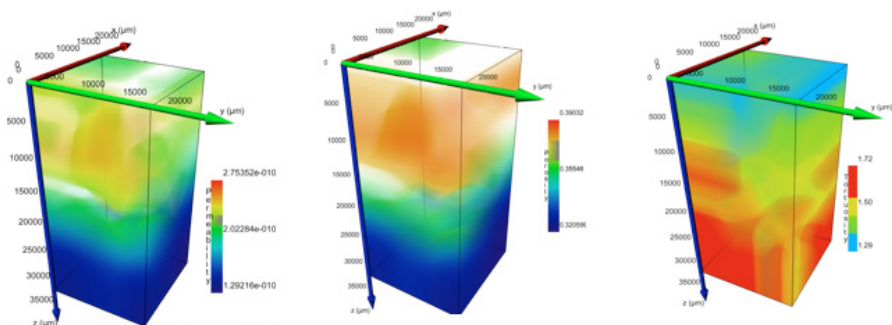



Prof.dr. SJMH Hulscher

The work of the “Water Engineering and Management (WEM) group was originally mainly devoted to the modelling of sand waves on the seabed. First it was shown, that the seabed patterns in the North Sea can be explained as free instabilities of the seabed. Subsequently, the modelling of sand waves was extended and refined. The group has worked on a scientific and practical tool for fully nonlinear modelling of sand waves. Over the last five years, the offshore morphodynamic work has broadened to rivers, coasts and blue-ice. Alternate bars in a flume were compared with (Ginzburg-)Landau-type models. The group was the first to explore data assimilation for morphodynamic predictions. Further work concentrated on using data assimilation to combine field data with sand wave amplitude models for maintenance dredging management of navigation channels and sand wave-related pipeline problems. Also, North Sea data were analysed and a new bed mode, called long bedwaves, was discovered. The origin of nearshore bars was addressed. A method was developed for modelling human interferences in a morphodynamic setting. This has opened perspectives for a new approach towards modelling large-scale sand mining in shallow seas. A project for developing tools for evaluation of human interference in the North Sea for optimal management of the seabed started recently and sediment transport concerning near-shore sand pits is being investigated. Since 2000 the group has studied the use of morphodynamical models in a societal context. Recently, a method for decision making based on quantitative information including uncertainties was developed in the multidisciplinary project Flyland, which opens the field of designing an assessment framework for appropriate modelling.

UNCOVERING INHERENT DYNAMICS IN COUPLED BIO-GEOMORPHODYNAMIC SYSTEMS OFFSHORE

PROJECT AIM

On the bed of the North Sea sand waves are present, which grow up to 25% of the water depth and migrate at a speed of tens of meters per year. These sand waves can pose a hazard to offshore constructions, navigation, pipelines and telecommunication cables. On the other hand, bed forms can protect the coastline against storms. The bottom of the North Sea is also covered by a great number of organisms live in and on the bottom of the sea. These organisms try to optimize their habitat, resulting in bio-geomorphological interactions. The precise interaction between the biological activity and geomorphodynamics is not known at this moment. Such knowledge is of great interest for reliable long-term geomorphodynamic predictions, especially in marine environments with large biological activities.

PROGRESS

Model and flume experiments are executed in which the biogeomorphological interactions are further analyzed. Moreover, model simulations are executed in which sand wave formation is investigated.

DISSERTATIONS

1. Borsje, B.W., 2012. Biogeomorphology of coastal seas. University of Twente, PhD thesis, 168 pp.

SCIENTIFIC PUBLICATIONS

1. Borsje, B.W., Roos, P.C., Kranenburg, W.M., Hulscher, S.J.M.H., 2013. Modelling tidal sand wave formation in a numerical shallow water model: the role of turbulence formulation. Continental Shelf Research.

PROJECT LEADERS

SJM Hulscher

RESEARCH THEME

Mathematical and computational methods for fluid flow analysis

PARTICIPANTS

BW Borsje, PMJ Herman, SJMH Hulscher

COOPERATIONS

Deltares, NIOZ

FUNDED

| | |
|--------------|-------|
| STW | |
| University | - |
| FOM | - |
| STW | 100 % |
| NWO Other | - |
| Industry | - |
| TNO | - |
| GTI | - |
| EU | - |
| Scholarships | - |

START OF THE PROJECT

2007

INFORMATION

BW Borsje
053 489 4038
b.w.borsje@utwente.nl

PROJECT LEADERS

SJMH Hulscher

RESEARCH THEME

Complex dynamics of fluids

PARTICIPANTS

W Chen, PC Roos, HM Schuttelaars,
SJMH Hulscher

COOPERATIONS

Closely linked to Future Ems project
and TU Delft

FUNDED

University of Twente
CSC (China Scholarship Council)
scholarship
Future Ems project
University -
FOM -
STW -
NWO Other -
Industry -
TNO -
GTI -
EU -
Scholarships 100 %

START OF THE PROJECT

2011

INFORMATION

WL Chen
053 489 2959
w.chen-3@utwente.nl
www.wem.ctw.utwente.nl

PROJECT AIM

The main objective of this project is to understand a scientific problem: how does 'basin-scale' sand extraction affect the set-up at the coast, both in the short term (immediately after extraction) and in the long term (through changes in morphology)? And solve a design problem: to warrant coastal safety, is it possible to shape the sand extractions required for nourishments and land reclamations such that potentially adverse effects of these interventions are minimized? Develop a three-dimensional hydro- and morphodynamic model that allowing for a quick and systematic analysis of residual circulation and set-up at the coast, accounting for the basin's morphodynamic evolution, the balance is between wind stress, atmospheric pressure gradient, density gradient, and river runoff. This model should (1) provide insight into the physical mechanisms, and (2) serve as a tool to analyze the impacts of various spatial extraction scenarios.

PROGRESS

In the year of 2013-2014, we developed a 3D semi-analytical surge model, time domain were transformed into frequency spectrum by Fourier transforming the signal, finally, the partial differential problem of surface elevation was solved numerically by using Finite element method. The sensitivity of surge level on storm parameters was investigated, this work is presented on the user group meeting, next step is to investigate the effect of geometry and topography on surge level. The resonant properties of coastal basin is very essential to coastal safety, to understand the physics behind, we developed a 3D time-dependent analytical model where a so-called collocation technique is used to study resonant frequencies due to different wind patterns (uniform, varying in along-wind and cross-wind). In weak rotation case, the solution is expanded in dimensionless coriolis parameter, solution is viewed as superposition of non-rotating flow with weak rotating correction, additional resonant peaks apart from classical half wave length peaks (Ponte 2010) is linked to rotation effect. These work are presented on Scheldt-Ems workshop at Antwerp (13th Feb 2014).

DISSERTATIONS

-

SCIENTIFIC PUBLICATIONS

-

SHORT-TERM BIOPHYSICAL INTERACTIONS IN COASTAL MANGROVES

PROJECT AIM

Short-term bio-physical interactions in coastal mangroves such as tidal flow routing, sediment deposition patterns and wave attenuation, contribute to coastal stabilization and coastal safety. The present study links spatially explicit observations and simulations of these processes to gradients in elevation and vegetation. This project aims to improve our understanding of the short-term bio-physical interactions in coastal mangroves by (i) collecting and analyzing a comprehensive set of field data, (ii) unraveling contributing processes through numerical modeling, based on the field observations and (iii) simulating system behavior for conditions beyond the observed field data.

PROGRESS

A process-based numerical model has been set-up in Delft3D for one of the mangrove sites where field data were collected. Both a 3D and a depth-averaged (2DH) version of the model were extensively calibrated and validated with the field data. It was concluded that both model delivered accurate results, yet the 2DH model was far more efficient. This 2DH model was subsequently used to simulate the initial response of the mangrove system to instantaneous changes of multiple biogeophysical conditions. This sensitivity analysis gave an indication of the system's potential to adapt to changing conditions due to human threats. Additionally, the wave propagation along two cross-shore mangrove transects was studied, unraveling the contribution of the vegetation density to wave attenuation. These results were linked as well to sediment deposition rates, showing how wave attenuation facilitates deposition.

DISSERTATIONS

-

SCIENTIFIC PUBLICATIONS

1. Horstman, E.M., C.M. Dohmen-Janssen & S.J.M.H. Hulscher (2013). Flow routing in mangrove forests: A field study in Trang province, Thailand. *Continental Shelf Research*, 71, 52-67. DOI: 10.1016/j.csr.2013.10.002.
2. Balke, T., T.J. Bouma, P.M.J. Herman, E.M. Horstman, C. Sudtongkong & E.L. Webb (2013). Cross-shore gradients of physical disturbance in mangroves: implications for seedling establishment. *Biogeosciences*, 10(8), 5411-5419. DOI: 10.5194/bg-10-5411-2013.
3. Horstman, E.M. & C.M. Dohmen-Janssen (2013). Bio-physical interactions in mangroves. In: E. Meilianda et al. (Eds.), *Proceedings of the Aceh International Symposium on Civil Engineering (AISCE)*, 19-20 September 2013, Banda Aceh. Banda Aceh: University of Syiah Kuala.
4. Horstman, E.M., C.M. Dohmen-Janssen & S.J.M.H. Hulscher (2013). Modeling tidal dynamics in a mangrove creek catchment in Delft3D. In: P. Bonneton & T. Garlan (Eds.), *Extended abstracts of Coastal Dynamics 2013*, 24-28 June 2013, Arcachon, France (pp. 833-844). Arcachon: SHOM.
5. Horstman, E.M., C.M. Dohmen-Janssen & S.J.M.H. Hulscher (2013). Modelling mangrove dynamics; simulating flow routing and sediment deposition patterns in Delft3D. In: *Book of abstracts NCK-Days 2013*, 14-15 March 2013, Kijkduin, The Netherlands. Delft: NCK.

PROJECT LEADERS

SJM Hulscher,
CM Dohmen-Janssen

RESEARCH THEME

Complex dynamics of fluids

PARTICIPANTS

EM Horstman, Dohmen-Janssen,
SJM Hulscher, PMJ Herman,
TJ Bouma, EL Webb, DA Friess,
C Sudtongkong, D Galli, T Balke

COOPERATIONS

Singapore-Delft Water Alliance,
Deltares, National University
of Singapore, Public Utilities
Board Singapore, Rajamangala
University of Technology Srivijaya,
Chulalongkorn University

FUNDED

| | |
|--------------------------------|------|
| Singapore-Delft Water Alliance | |
| University | 25 % |
| FOM | - |
| STW | - |
| NWO Other | - |
| Industry | 75 % |
| TNO | - |
| GTI | - |
| EU | - |
| Scholarships | - |

START OF THE PROJECT

2009

INFORMATION

E Horstman
053 489 28 21
E.M.Horstman@utwente.nl
www.utwente.nl/ctw/wem/organisatie/
medewerkers/horstman.doc

A creek dissecting a dense mangrove forest forms a major supply route for tidal water fluxes.



PROJECT LEADERS

SJMH Hulscher

RESEARCH THEME

Complex dynamics of fluids

PARTICIPANTS

L Duarte Campos, KM Wijnberg,
SJMH Hulscher

COOPERATIONS

Closely linked to:

NatureCoast Project

CoCoChannel Project.

FUNDED

CONICYT (National Commission
for Scientific and Technological
Research of Chile)

University -

FOM -

STW -

NWO Other -

Industry -

TNO -

GTI -

EU -

Scholarships 100 %

START OF THE PROJECT

2013

INFORMATION

L Duarte Campos

053 489 1094

l.a.duarte campos@utwente.nl

[http://www.utwente.nl/ctw/wem/
organisatie/medewerkers/duarte%20
campos/Leonardo_Duarte/](http://www.utwente.nl/ctw/wem/organisatie/medewerkers/duarte%20campos/Leonardo_Duarte/)

PROJECT AIM

The objective of this study is to explore how well the sand exchange between marine and aeolian process can be calculated using existing and long-term monitoring data. The project focuses on increasing the understanding into the extent to which the intertidal zone can function as a sediment source for onshore aeolian transport. This zone is expected to be a crucial element in the relationship between dune development and the dynamics of nearshore bars in the long-term.

PROGRESS

During the first 6 months of the project, I have worked in the elaboration of PhD proposal, reading thesis and papers related to aeolian and marine processes in the nearshore zone to know the State of the Art. An abstract was submitted, December 2013, for the Latin-American Conference of Hydraulics 2014.

DISSERTATIONS

-

SCIENTIFIC PUBLICATIONS

-

RIVER BED FORM EVOLUTION MODELING FOR FLOOD MANAGEMENT

PROJECT AIM

Subproject 1: Dune evolution and transition to plane beds (van Duin)

The overall objective of this subproject is to model and better understand (1) the (processes leading to) the transition to upper-stage plane beds, (2) the evolution and occurrence of specific dune morphologies (e.g. superimposed dunes, low-angle dunes) and (3) the roughness associated with the aforementioned bed configurations.

Subproject 2: The influence of suspended sediment transport on dune evolution (Naqshband)

The overall objective of this subproject is to model and better understand the effects of suspended load on (1) dune morphology, (2) dune evolution and (3) transition from dunes to upper stage plane beds.

Subproject 3: Application of bed form roughness in operational flood modelling (Warmink)

The objective of this subproject is to apply the knowledge acquired in subprojects 1 & 2 for operational forecasting of water levels.

PROGRESS

In the past period the main focus for subproject 1 was to 1) test different bed load transport formulations for their potential to predict upper-stage plane bed, 2) further optimize pick-up and deposition models and underlying step length models, 3) validating the resulting dune evolution model with a dataset used by Shimizu et al. to prove that we can predict upper-stage plane bed and hysteresis effects. For subproject 2 the main focus was to process and analyse data from the second experimental series carried out in Braunschweig (November 2012 to January 2013). The analysis of this data set showed promising results in quantifying the contribution of bed and suspended load to migrating dunes in equilibrium. Furthermore, the processes found from the experimental data is now being incorporated in the dune evolution model to better predict dune dimensions and therefore water levels. Subproject 3 focused on improvement of the water level predictions using an improved bed form evolution model under unsteady discharge in alluvial rivers (assuming alluvial bed forms in the river reach). We implemented a physically based roughness model of Coleman et al. (2005) in a hydrodynamic model and successfully applied this to a flume and field situation. Preliminary results showed that the physically based model is able to replicate the calibrated model, without the need for calibration.

DISSERTATIONS

-

SCIENTIFIC PUBLICATIONS

1. Warmink, J.J., Straatsma, M.W., Huthoff, F., Booi, M.J., Hulscher, S.J.M.H. (2013). Uncertainty of design water levels due to combined bed form and vegetation roughness in the Dutch river Waal. *Journal of Flood Risk Management* 6(4) 302-318. DOI: 10.1111/jfr3.12014.
2. Van Duin, O.J.M., J.S. Ribberink, C.M. Dohmen-Janssen and S.J.M.H. Hulscher. (2013). Modelling sediment pick-up and deposition in a dune model. Van Lancker, V. and Garlan, T. (Eds), MARID 2013. Fourth International Conference on Marine and River Dune Dynamics. Bruges, Belgium, 15-17 April 2013. Royal Belgian Institute of Natural Sciences and SHOM. VLIZ Special Publication 65 – Flanders Marine Institute (VLIZ). Oostende, Belgium. 338p. ISSN 1377-0950. ISBN 978-2-11-128352-7.

PROJECT LEADERS

SJM Hulscher,
CM Dohmen-Janssen

RESEARCH THEME

Mathematical and computational methods for fluid flow analysis

PARTICIPANTS

OJM van Duin, S Naqshband,
JJ Warmink, JS Ribberink,
R Schielen, AJ Paalberg

COOPERATIONS

Deltares, HKV, Rijkswaterstaat,
Waterdienst, University of
Braunschweig

FUNDED

NWO/STW, University of Twente,
Deltares/RWS, HKV
University 45 %
FOM 50 %
STW -
NWO Other -
Industry 5 %
TNO -
GTI -
EU -
Scholarships -

START OF THE PROJECT

2010

INFORMATION

OJM van Duin
O.J.M.vanDuin@utwente.nl

S Naqshband
S.Naqshband@utwente.nl

J.J. Warmink
J.J.Warmink@utwente.nl

3. Van Duin, O.J.M., Ribberink, J.S., Dohmen-Janssen, C.M., Hulscher, S.J.M.H. (2013). Modelling pick-up and deposition in a dune model. In: A. Crosato (ed.) Teaming up with nature and nations. Book of Abstracts NCR-Days 2013, October 3-4, Delft, The Netherlands. NCR Publication 37-2013. ISSN 1568-234X.
4. Warmink, J.J., Schielen, R.M.J., Dohmen-Janssen, C.M. (2013). Evolution of bed form height and length during a discharge wave. Proc. of the Marine and River Dune Dynamics conference (MARID IV), Bruges, Belgium, pp. 323-329.
5. Warmink, J.J., Schielen, R.M.J., Dohmen-Janssen, C.M. (2013). Dune dynamics under gradually varying discharge, flume vs field observations. Abstract for the River Coastal and Estuarine Morphodynamics conference (RCEM), Santander, Spain.
6. Warmink, J.J. (2013). Modelling dune evolution under a discharge wave. Proc. NCR-days 2013, Delft, the Netherlands, pp. 3:17-3:18.
7. Naqshband, S., Ribberink, J.S., Hurther, D. & Hulscher, S.J.M.H. (2013). Sediment transport distribution along equilibrium sand dunes. Van Lancker, V. and Garlan, T. (Eds), MARID 2013. Fourth International Conference on Marine and River Dune Dynamics. Bruges, Belgium, 15-17 April 2013. Royal Belgian Institute of Natural Sciences and SHOM. VLIZ Special Publication 65 – Flanders Marine Institute (VLIZ). Oostende, Belgium. 338p. ISSN 1377-0950. ISBN 978-2-11-128352-7.
8. Naqshband, S., Ribberink, J.S., Hurther, D. & Hulscher, S.J.M.H. (2013). Bed and suspended flux distribution along migrating dunes. In A. Crosato (Ed.), Book of abstracts NCR-days 2013, 3-4 October 2013, Delft (pp. 39-40). Delft: UNESCO-IHE.

PROJECT AIM

The main research objective is to enhance the understanding of turbidity dynamics and its effects on Lake Naivasha ecosystem. This will be achieved by: investigating spatial-temporal variability of turbidity in Lake Naivasha using field measurements coupled with Earth Observation and Geo-information, identifying the main drivers and mechanisms that influence the turbidity dynamics in Lake Naivasha, investigating the shift from clear to turbid state in Lake Naivasha and finally by quantifying changes in fish population (in terms of annual fish catches per species) in relation to turbidity changes in Lake Naivasha.

PROGRESS

Two papers have been accepted for publication, one is submitted and one is in preparation. A chapter on Hydrodynamics is also underway.

DISSERTATIONS

-

SCIENTIFIC PUBLICATIONS

1. Ndungu, J.N., Monger, B.C., Augustijn, D.C.M., Hulscher, S.J.M.H., Kitaka, N. & Mathooko, J.M. (2013). Evaluation of spatio-temporal variations in chlorophyll-a in Lake Naivasha, Kenya: remote-sensing approach, doi: 10.1080/01431161.2013.833359. *International journal of remote sensing*, 34(22), 8142-8155.
2. Ndungu, J., Augustijn, D.C.M., Hulscher, S.J.M.H., Kitaka, N., and Mathooko, J. (2013) Spatio-temporal variations in the trophic status of Lake Naivasha, Kenya Lakes and Reservoirs: Research and Management 18, 1-12.
3. Ndungu, J.N., Augustijn, D.C.M. & Hulscher, S.J.M.H. (2013). A remote sensing approach in evaluation of spatio-temporal variation in chlorophyll-a concentrations in Lake Navaisha, Kenya. In 4th International multidisciplinary conference on hydrology and ecology (HydroEco'2013): emerging patterns, breakthroughs and challenges, 13-16 May 2013, Rennes, France (pp. 165-165). Rennes, France.
4. Ndungu, J.N. (2013). Multivariate approach in the assessment of the status of water quality in Lake Navaisha. In Z. Heiszler & R. Hohol (Eds.), *Book of Abstracts 32nd Congress of the International Society of Limnology*, 4-9 August 2013, Budapest, Hungary (pp. 207-207). Tihany, Hungary: Balaton Limnological Institute.
5. Ndungu, J.N., Augustijn, D.C.M. & Hulscher, S.J.M.H. (2013). Best Poster Award: A remote sensing approach in evaluation of spatio-temporal variation in chlorophyll-a concentrations in Lake Navaisha, Kenya. 4th International multidisciplinary conference on hydrology and ecology: emerging patterns, breakthroughs and challenges, 13-16 May 2013, Rennes, France: Rennes, France (2013, mei 13 - 2013, mei 16).

PROJECT LEADERS

SJMH Hulscher

RESEARCH THEME

Mathematical and computational methods for fluid flow analysis

PARTICIPANTS

J Ndungu, D Augustijn, N Kitaka, J Mathooko, SJMH Hulscher

COOPERATIONS

Closely linked to: EOIA Naivasha project: <https://sites.google.com/site/eoianavasha/>

FUNDED

| | |
|--------------|-------|
| WOTRO | |
| University | - |
| FOM | - |
| STW | - |
| NWO Other | - |
| Industry | 100 % |
| TNO | - |
| GTI | - |
| EU | - |
| Scholarships | - |

START OF THE PROJECT

2010

INFORMATION

J Ndungu
06 476 04589
J.N.Ndungu@utwente.nl
www.wem.ctw.utwente.nl

PROJECT LEADERS

SJMH Hulscher, JJ Warmink,
RMJ Schielen

RESEARCH THEME

Mathematical and computational
methods for fluid flow analysis

PARTICIPANTS

Ir. J.P. Aguilar López, Dr. J.J.
Warmink, Dr. R.M.J. Schielen, Dr. Ir.
Dohmen-Janssen, Prof. Dr. S.J.M.H.
Hulscher, Prof. Dr. M. Kok

COOPERATIONS

Deltares, HKV, Rijkswaterstaat,
Waterdienst, Arcadis

FUNDED

STW-perspectif
University -
FOM -
STW 100 %
NWO Other -
Industry -
TNO -
GTI -
EU -
Scholarships -

START OF THE PROJECT

2012

INFORMATION

J Pablo Aguilar
053 489 40 38
j.p.aguilarlopez@utwente.nl
[http://www.utwente.nl/ctw/wem/
organisatie/medewerkers/aguilardoc](http://www.utwente.nl/ctw/wem/organisatie/medewerkers/aguilardoc)

PROJECT AIM

Flood risk safety philosophy is changing more and more in the direction of a system probability of failure approach, which should replace the current overload per dike section approach. The project aims to:

- Estimate the main failure mechanisms considering their possible correlations with other functions .
- Derive set of limit state equations based in other common variables.
- Emulate the failure mechanisms from model.
- Implement the methodology in the current safety assessment.

PROGRESS

The first part of the study consists the analysis of the impact of correlation between , variables, failure mechanisms and functions. At the moment , the first finding probed that correlation between variables for the probabilistic assessment will influence substantially the outcome of the failure estimation. For the case of backward erosion also known as piping , correlation between the sand grain size and the permeability might influence the outcome by several orders of magnitude. However the trend shows that the actual assessment is quite conservative without considering the correlation (See figure).

DISSERTATIONS

-

SCIENTIFIC PUBLICATIONS

1. Aguilar J.P., Schielen R.M.J., Warmink J.J. & Hulscher, S.J.M.H. (2012). Safety assessment of multi-functional flood defenses , Book of abstracts Nederlands Centrum voor Riverkunde NCR-days (pp 19-21), 4th October – 5th October 2012, Arnhem-The Netherlands.
2. Aguilar J.P., Schielen R.M.J., Warmink J.J. & Hulscher, S.J.M.H. (2013). Study of failure mechanisms of multi-functional flood defenses , Book of abstracts Nederlands Centrum voor Riverkunde NCR-days (pp 29-30), 3th October – 4th October 2012, Delft -The Netherlands.
3. Aguilar J.P., Schielen R.M.J., Warmink J.J. & Hulscher, S.J.M.H. (2013). Flood defence design parameters correlation influence on failure probability estimation (Paper accepted for oral presentation) 3rd IAHR Europe Congress, Portugal 2014.

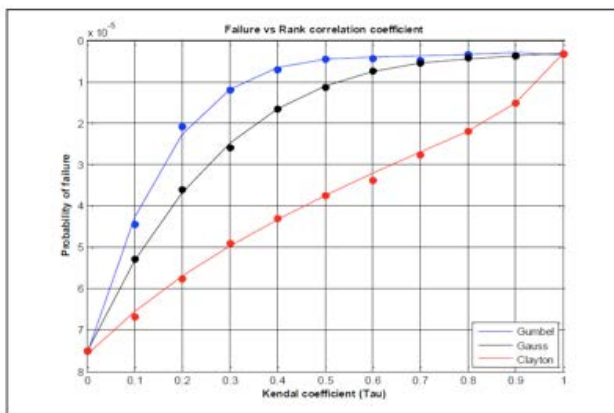

PROJECT AIM

The research has two main aims: (1) to improve understanding of the near-bed hydrodynamics and sand transport processes occurring under real-scale irregular non-breaking and regular breaking wave conditions and (2) to develop a new practical model for predicting sand transport under waves, accounting for wave irregularity and wave breaking in a way that is well founded on experimental data and understanding of the fundamental processes. The research is based on a combination of fixed and mobile bed laboratory experiments (incl. PhD-project J.van der Zanden) and process-based numerical modeling (incl. post-doc W.M. Kranenburg). The obtained insights in key hydrodynamic and sediment processes, together with the quantitative measures of net sand transport rates, will be used to develop practical parameterized formulas to be implemented in morphodynamic modeling systems (e.g. Delft3D, Deltares). The project builds upon an earlier project on sand transport under regular non-breaking waves.

PROGRESS

Measurements on flow, turbulence, sediment concentrations and transport under irregular and breaking waves have taken place in the large scale wave flume in Barcelona. A numerical model developed before for flow and transport under regular non-breaking waves has been validated for transport by irregular waves and applied in a parameter study.

DISSERTATIONS

1. Kranenburg, W.M. (2013) Modeling sheet-flow sand transport under progressive surface waves. University of Twente, PhD thesis, 174 pp.

SCIENTIFIC PUBLICATIONS

1. Kranenburg, W.M., J.S. Ribberink, J.L.M. Schretlen and R.E. Uittenbogaard (2013) 'Sand transport beneath waves: the role of progressive wave streaming and other free surface effects', *J. Geophys. Res.* DOI:10.1029/2012JF002427.
2. Van der A, D.A., J.S. Ribberink, J.J. Van der Werf, T. O'Donoghue, R.H. Buijsrogge and W.M. Kranenburg (2013); Practical sand transport formula for non-breaking waves and currents, *Coastal engineering*, 76 . 26 - 42., ISSN 0378-3839 <http://dx.doi.org/10.1016/j.coastaleng.2013.01.007>.
3. Kranenburg, Wouter and Jan Ribberink (2013); Progressive wave effects on boundary layer flow and sheet-flow sediment transport, in: Bonneton and Garlan (Eds.), *Proceedings of Coastal Dynamics 2013*, Archachon, France, 2013.
4. Van der Werf, J.J., K. Neessen, J.S. Ribberink and W.M. Kranenburg (2013). Wave breaking effects on mean surf zone hydrodynamics. In: Bonneton and Garlan (Eds.), *Proceedings of Coastal Dynamics 2013*, Archachon, France, 2013.
5. Van der Zanden, J., J.M. Alsina, I. Cacéres, R.H. Buijsrogge and J.S. Ribberink (2013). New CCM technique for sheet flow measurements and its first application in swash zone experiments. In: F. Sancho (Eds), *Proceedings of 6th International Short course / Conference on Applied Coastal Research (SCACR)*, Lisbon, Portugal, 2013.

PROJECT LEADERS

JS Ribberink

RESEARCH THEME

Complex dynamics of fluids

PARTICIPANTS

WM Kranenburg, J van der Zanden,
JJ van der Werf

COOPERATIONS

Deltares, University of Aberdeen, UK
University of Liverpool, UK,
Bangor University, UK, Universitat
Politécnica de Catalunya,
LEGI, Grenoble, Fr, National
Oceanography Centre, UK

FUNDED

SINBAD (STW/EPSRC), Hydralab
IV-WISE (EU)

| | |
|--------------|------|
| University | 80 % |
| FOM | - |
| STW | - |
| NWO Other | - |
| Industry | - |
| TNO | - |
| GTI | - |
| EU | 20 % |
| Scholarships | - |

START OF THE PROJECT

2012

INFORMATION

WM Kranenburg

053 489 2959

w.m.kranenburg@utwente.nl

www.utwente.nl/ctw/wem/

PROJECT LEADERS

KM Wijnberg

RESEARCH THEME

Complex dynamics of fluids

PARTICIPANTS

AJ van der Weerd, SJMH Hulscher

COOPERATIONS

Wageningen University, Delft University of Technology, Utrecht University, VU University of Amsterdam, NIOZ, Alterra, United States Geological Service (USGS), Deltares

FUNDED

| | |
|--------------|-------|
| STW | |
| University | - |
| FOM | - |
| STW | 100 % |
| NWO Other | - |
| Industry | - |
| TNO | - |
| GTI | - |
| EU | - |
| Scholarships | - |

START OF THE PROJECT

2013

INFORMATION

L van der Weerd
053 489 8038
a.j.vanderweerd@utwente.nl
<http://www.utwente.nl/ctw/wem/organisatie/medewerkers/weerd/lianne/>

PROJECT AIM

Recently, a mega-nourishment (21 Mm³ of sand) has been built at the Dutch coast. This is an innovative way of nourishing which is expected to protect the coast for approximately 20 years. The goal of this study is to describe and explain the impact of mega-nourishments on spatial and temporal variation in aeolian sediment supply (i.e. wind-driven) towards the upper beach and foredunes on a medium long time scale (e.g. 20 years). Currently, it is still unresolved how to estimate longer term and larger scale dune behaviour, although this knowledge is essential for assessing coastal dune safety. The research is part of an "STW Perspectief Programma" NatureCoast.

PROGRESS

The project started in February 2013. As a start, relevant literature was studied. Also several courses were taken to improve the researchers skills. A research plan was written in which the goals, research questions and methods were elaborated to the required level of detail. Additionally, several field visits to the Zandmotor were done in order to get to know the area and to do exploratory measurements. Finally, we have been investigating and deciding what measurement equipment we would like to purchase.

DISSERTATIONS

-

SCIENTIFIC PUBLICATIONS

1. Weerd, A.J. van der, Wijnberg, K.M., Werf, J.J. van der, Walstra, D.J.W. & Ribberink, J.S. (2013). Wave-driven dynamics of shoreward propagating accretionary waves. In Book of abstracts RCEM 2013.
2. Weerd, A.J. van der, Wijnberg, K.M., Werf, J.J. van der & Walstra, D.J. (2013). Wave-driven dynamics of Shoreward Propagating Accretionary Waves. In B.C. van Prooijen & N.C. Volp (Eds.), Book of abstracts NCK-days 2013, 13-15 March 2013, Kijkduin (pp. 1-1). Delft: Technische Universiteit Delft.
3. Hoonhout, B., S. de Vries, F. Baart, J. van Thiel de Vries, A.J. van der Weerd, K.M. Wijnberg (2013). Monitoring of beach surface properties with remote sensing. Coastal Dynamics Conference Proceedings, 821-832.



Prof.dr. AEP Veldman

The group Computational Mechanics and Numerical MathemThe group Computational Mechanics and Numerical Mathematics at the University of Groningen focuses on the development of numerical solution methods for partial differential equations in general, and for (aero- and hydrodynamic) flow simulation in particular (CFD). Keywords for our algorithmic developments are symmetry-preserving discretization, Cartesian cut-cell approach, sharp-interface methods, efficient sparse-matrix solvers and large-scale continuation methods. It is our strategy to combine all algorithmic innovations from the individual research projects into one coherent CFD concept, such that all projects can profit from each other.

Application areas are direct and large-eddy simulation of turbulent flow, free-surface flow in aerospace (sloshing onboard spacecraft) and maritime engineering (hydrodynamic wave loading), oceanography (stability of the global ocean circulation), bio-medical fluid dynamics (hemodynamics) and heat transport (Rayleigh-Bénard flow). We plan to extend our thus far mainly mono-disciplinary flow problems towards multi-physics: fluid-structure interaction, two-phase flow, atmospheric flow and turbulent combustion. In the process of knowledge transfer, the in-house developed computer codes ComFlo and MRILU play an important role. atics at the University of Groningen focuses on the development of numerical solution methods for partial differential equations in general, and for (aero- and hydrodynamic) flow simulation in particular (CFD). Keywords for our algorithmic developments are symmetry-preserving discretization, Cartesian cut-cell approach, sharp-interface methods, efficient sparse-matrix solvers and large-scale continuation methods. It is our strategy to combine all algorithmic innovations from the individual research projects into one coherent CFD concept, such that all projects can profit from each other.

Application areas are direct and large-eddy simulation of turbulent flow, free-surface flow in aerospace (sloshing onboard spacecraft) and maritime engineering (hydrodynamic wave loading), oceanography (stability of the global ocean circulation), bio-medical fluid dynamics (hemodynamics) and heat transport (Rayleigh-Bénard flow). We plan to extend our thus far mainly mono-disciplinary flow problems towards multi-physics: fluid-structure interaction, two-phase flow, atmospheric flow and turbulent combustion. In the process of knowledge transfer, the in-house developed computer codes ComFlo and MRILU play an important role.

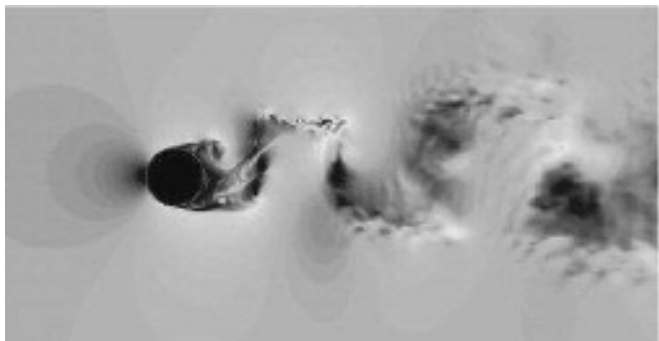
Snapshot of a simulated turbulent flow at $Re=3900$

PROJECT AIM

A main area of research concerns turbulent flow simulation. Turbulence modeling keeps computational effort within reasonable limits, but a price is paid in terms of accuracy. Thus research into direct numerical simulation (DNS) methods that resolve all length and time scales is envisaged. Our group concentrates on improving numerical techniques (space discretization and time integration) with which the price of DNS can be reduced significantly. Additionally, steps towards mathematical-based LES modeling are made.

PROGRESS

The aim of the project is to model and simulate turbulence such that the symmetry and conservation properties of the Navier-Stokes equations are preserved. In cooperation with MARIN a PhD-project was continued which aims to extend the method to unstructured grids at high Reynolds numbers. As an example, the flow past a circular cylinder has been computed. The joint work with UPC (Barcelona) on symmetry-preserving discretization and regularization has led to a paper. In cooperation with NLR a PhD-project was continued in which a detailed numerical simulation method for turbulent flow over aircraft wings is developed. Results have been presented at two international conferences; a journal paper has been accepted. In September 2013, a new NWO-funded PhD-project has been started that focuses on models for the larger eddies in turbulent flow.

DISSERTATIONS

-

SCIENTIFIC PUBLICATIONS

1. W. Rozema, R.W.C.P. Verstappen, J.C. Kok and A.E.P. Veldman, A symmetry-preserving discretization and regularization subgrid model for compressible turbulent flow. Proc. 9th ERCOFTAC Workshop Direct and Large Eddy Simulation DLES 9, Dresden, April 3-5, 2013 (6 pages).
2. F.X. Trias, A. Gorobets, A. Oliva, R.W.C.P. Verstappen, New differential filters for large eddy simulation and regularization modeling. Proc. 9th ERCOFTAC Workshop Direct and Large Eddy Simulation DLES 9, Dresden, April 3-5, 2013 (6 pages).
3. Roel Verstappen, On scale separation in large eddy simulation. Proc. 9th ERCOFTAC Workshop Direct and Large Eddy Simulation DLES 9, Dresden, April 3-5, 2013 (10 pages).
4. W. Rozema, J.C. Kok, R.W.C.P. Verstappen and A.E.P. Veldman, A symmetry-preserving discretization and regularization subgrid model for compressible turbulent flow. Proc. 8th Int. Symp. on Turbulence and Shear Flow Phenomena TSFP 8, Poitiers, Aug. 28-30, 2013.
5. Roel Verstappen, Blended scale-separation models for large eddy simulation. Proc. 14th European Turbulence Conference ETC 14, Lyon Sept. 1-4, 2013.
6. F.X. Trias, R. Verstappen, A. Gorobets and A. Oliva, Progress on eddy-viscosity models for LES: new differential operators and discretization methods. Proc. 14th European Turbulence Conference ETC 14, Lyon Sept. 1-4, 2013.

PROJECT LEADERS

RWCP Verstappen

RESEARCH THEME

Mathematical and computational methods for fluid flow analysis

PARTICIPANTS

HJ Bandringa, AJA Kort, JA Helder, W Rozema, MH Silvis, RWCP Verstappen, FW Wubs, AEP Veldman, FX Trias (UPC), A Oliva (UPC), A Baez (UPC), P Moin (CTR)

COOPERATIONS

NLR, MARIN, TUD, UT, Polytechnical University of Catalunya (Barcelona), Stanford University

FUNDED

Agentschap NL (EZ), Ubbo Emmius Fonds (RUG)

| | |
|--------------|------|
| University | 30 % |
| FOM | - |
| STW | - |
| NWO Other | 20 % |
| Industry | 10 % |
| TNO | - |
| GTI | - |
| EU | 30 % |
| Scholarships | 10 % |

START OF THE PROJECT

1998

INFORMATION

RWCP Verstappen
 050 363 3958
R.W.C.P.Verstappen@rug.nl
www.math.rug.nl/~veldman/DNS/dns-home

Vortical structures in the wake of a square cylinder at Re=22000.

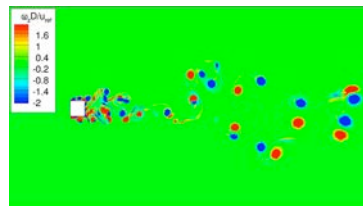

NUMERICAL METHODS FOR THE INCOMPRESSIBLE NAVIER-STOKES EQUATIONS

PROJECT LEADERS

FW Wubs

RESEARCH THEME

Mathematical and computational methods for fluid flow analysis

PARTICIPANTS

S Kotnala, w Song, FW Wubs, HA Dijkstra (IMAU) JThies (DLR)

COOPERATIONS

IMAU (UU), DLR, TU Braunschweig, University Erlangen

FUNDED

| | |
|--------------|-------|
| NWO | |
| University | - |
| FOM | - |
| STW | - |
| NWO Other | 100 % |
| Industry | - |
| TNO | - |
| GTI | - |
| EU | - |
| Scholarships | - |

START OF THE PROJECT

1994

INFORMATION

FW Wubs
050 363 3994
f.w.wubs@rug.nl
www.math.rug.nl/~wubs

PROJECT AIM

The repeated solution of large systems of equations in most simulation methods makes the quest for improved matrix solvers another major research area. In-house a multilevel preconditioner (MRILU) and a new multilevel preconditioner for CFD problems (HYMLS) have been developed. Application area is the modelling of flow patterns in global ocean circulation (with UU-IMAU) and the study of the behavior of flows beyond but close to the transition point (self-sustaining structures, traveling wave solutions).

PROGRESS

A first version of the multilevel solver HYMLS has been finished; it has been coupled to eigenvalue solvers in the Trilinos package. It allows to perform bifurcation analysis on incompressible Navier-Stokes equations on systems up to 10 million unknowns in a few hours on a cluster with 128 nodes. In the new year a cooperation starts with the German Aerospace Laboratory (DLR) on the further development of HYMLS towards massively parallel computers with applications in eigenvalue problems from fluid dynamics. The numerical bifurcation analysis focuses on both academic flow problems (lid-driven cavity, Rayleigh-Benard problem), and flows in realistic geometries. With IMAU we work on bifurcation analysis of ocean flows in the presence of noise, leading to stochastic PDEs. The computation of self-sustaining coherent structures in near-wall turbulent flows is continued.

DISSERTATIONS

-

SCIENTIFIC PUBLICATIONS

1. W. Weijer, V. Zharkov, D. Nof, H. A. Dijkstra, W. P. M. de Ruijter, A. Terwisscha van Scheltinga, and F. Wubs (2013), Agulhas ring formation as a barotropic instability of the retroflection, *Geophys. Res. Lett.*, 40, 2013, 1-4.

The stability of the Kuroshio current (east of Japan) is investigated with bifurcation analysis

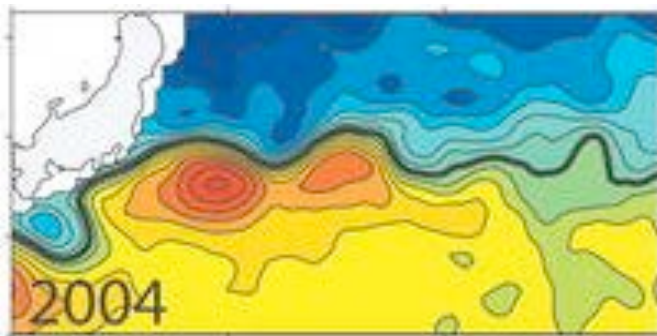

PROJECT AIM

A fast-growing application area of our ComFLOW simulation method is maritime technology. In close cooperation with MARIN, Deltares and the offshore industry, focus is on the numerical prediction of hydrodynamic wave loading (green water, slamming) and sloshing in ship tanks.

PROGRESS

The free-surface ComFLOW-3 project on hydrodynamic wave loading by extreme waves was continued. In the new developments, physical emphasis is on modelling viscous effects during wave impact. Hereto, a regularization model from our turbulent-flow research (see above) has been implemented, extended with a separate model for the near-wall treatment. Numerical efficiency is improved with local grid refinement and parallelization. The TUD-part of the project focusses on improved wave generation and propagation. All the developments are now being merged, and preparations for a few major validation test cases are being made, for which MARIN has finished a set of detailed experiments (flow in moonpools).

DISSERTATIONS

-

SCIENTIFIC PUBLICATIONS

1. B. Duz, R.H.M. Huijsmans, A.E.P. Veldman, M.J.A. Borsboom and P.R. Wellens. An Absorbing Boundary Condition for Regular and Irregular Wave Simulations. In: Eça, L.; Oñate, E.; García-Espinosa, J.; Kvamsdal, T.; Bergan, P. (Eds.) MARINE 2011, IV International Conference on Computational Methods in Marine Engineering, Selected Papers. Computational Methods in Applied Sciences, Vol. 29, Springer, ISBN 978-94-007-6142-1 (2013) pp. 31--46.
2. B. Duz, R. Huijsmans, A. Veldman, M. Borsboom and P. Wellens. The Effect of Different Volume-of-Fluid (VOF) Methods on Energy Dissipation in Simulations of Propagating Waves. In: B. Brinkmann and P. Wriggers (eds.) Computational Methods in Marine Engineering V, Hamburg, 29-31 May 2013, pp. 599-610.
3. H.J.L. van der Heiden, A.E.P. Veldman and R. Luppés. A quasi-3D extension of the LS-STAG cut-cell immersed boundary method. Euromech/Ercoftac Coll 549. Immersed Boundary Methods: Current Status and Future Research Directions. Leiden, 17-19 June (2013). (3 pags.)
4. H.J.L. van der Heiden, P. van der Plas, A.E.P. Veldman, R. Luppés and R.W.C.P. Verstappen. Simulation of Moonpool Water Motion. In: B. Brinkmann and P. Wriggers (eds.) Computational Methods in Marine Engineering V, Hamburg, 29-31 May 2013, pp. 356-364.
5. Henri J.L. van der Heiden, Peter van der Plas, Arthur E.P. Veldman, Roel Luppés and Roel W.C.P. Verstappen. Efficient Computation and Modeling of Viscous Flow Effects in ComFLOW. Proc. OMAE2013, Nantes, 10-14 June 2013, paper OMAE2013-11000.
6. R. Luppés, H.J.L. van der Heiden, P. van der Plas, A.E.P. Veldman and B. Düz. Simulations of Wave Impact and Two-Phase Flow with ComFLOW: Past and Recent Developments. Proc. ISOPE2013, Anchorage USA, 30 June - 5 July 2013, paper 2013-TPC-0241.
7. P. van der Plas, H. van der Heiden, R. Luppés and A. Veldman. Local Grid Refinement for Free-Surface Flow Simulations in Offshore Applications. In: B. Brinkmann and P. Wriggers (eds.) Computational Methods in Marine Engineering V, Hamburg, 29-31 May 2013, pp. 502-511.

PROJECT LEADERS

AEP Veldman

RESEARCH THEME

Mathematical and computational methods for fluid flow analysis

PARTICIPANTS

H.J.L. van der Heiden, P. van der Plas, R. Luppés, AEP Veldman, B. Duz (TUD), RHM Huijsmans (TUD), T. Bunnik (MARIN), JA Helder (MARIN), PR Wellens (Deltares), MJA Borsboom (Deltares)

COOPERATIONS

TU Delft, MARIN, Deltares, FORCE Technology (Norway)

FUNDED

| | |
|--------------|-------|
| STW | - |
| University | - |
| FOM | - |
| STW | 100 % |
| NWO Other | - |
| Industry | - |
| TNO | - |
| GTI | - |
| EU | - |
| Scholarships | - |

START OF THE PROJECT

1999

INFORMATION

AEP Veldman

050 363 3939

a.e.p.veldman@rug.nl

www.math.rug.nl/~veldman/comflow

Snapshot of a flow simulation, using local grid refinement, of waves around an offshore platform

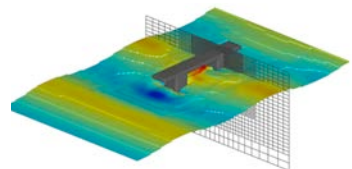

PROJECT LEADERS

B Carpentieri

RESEARCH THEME

Mathematical and computational methods for fluid flow analysis

PARTICIPANTS

G Liao, Y Bu, B Carpentieri YF Jing (Chengdu)

COOPERATIONS

U University Chengdu (China), University Napoli, University Lazio)

FUNDED

| | |
|--------------|------|
| University | 70 % |
| FOM | - |
| STW | - |
| NWO Other | - |
| Industry | - |
| TNO | - |
| GTI | - |
| EU | - |
| Scholarships | 30 % |

START OF THE PROJECT

2010

INFORMATION

B Carpentieri

050 363 3939

b.carpentieri@rug.nl

PROJECT AIM

The project aims at developing Krylov subspace solvers for general block-structured nonsymmetric linear systems. Applications are sparse nonsymmetric problems in quantum mechanics and dense complex non-Hermitian problems in electromagnetic scattering. The work extends to the development of sparse eigensolvers for Maxwell's equations in the analysis of dielectric waveguides.

PROGRESS

In a study with colleagues at Universita Federico II di Napoli and Universita di Cassino e del Lazio Meridionale, new preconditioning techniques have been developed for the analysis of large halo current models in next-generation thermonuclear fusion devices. In a joint project with the University of Chengdu, China, some novel stabilization techniques have been developed for a family of non-optimal Krylov subspace methods.

DISSERTATIONS

-

SCIENTIFIC PUBLICATIONS

1. J. Liao, T.Z. Huang, and B. Carpentieri, Two novel aggregation-based algebraic multigrid methods. *Miskolc Math. Notes*, 14(1), 2013, 143–158.
2. B. Carpentieri, J. Liao, and M. Sosonkina, VBARMS: A Variable Block Variant of the Algebraic Multilevel Solver for General Linear Systems. *Journal of Computational and Applied Mathematics*, 259 (A), 2013, 164–173.
3. Y.-F. Jing, T.-Z. Huang, B. Carpentieri, and Y. Duan, Exploiting the composite step strategy to the biconjugate A-orthogonal residual method for non-hermitian linear systems. *Journal of Applied Mathematics*, 2013, 2013, 1–16.
4. B. Carpentieri, J. Liao, and M. Sosonkina, Variable block multilevel iterative solution of general sparse linear systems. *Proc. 10th International Conference on Parallel Processing and Applied Mathematics PPAM, Warsaw, Poland, September 8-11, 2013*.
5. B. Carpentieri, J. Liao, and M. Sosonkina, A Parallel Variable Block Algebraic Recursive Multilevel Solver for General Sparse Linear Systems. *Proc. ParCo2013 Conference, Technical University of Munich, September 10-13, 2013*.
6. R. Albanese, B. Carpentieri, G. Rubinacci, S. Ventre, and F. Villone, Computational techniques for efficient analysis of large halo current models in next-generation thermonuclear fusion devices. *Proc. Computational Electromagnetics International Workshop, Izmir, Turkey, September 2-5, 2013*.

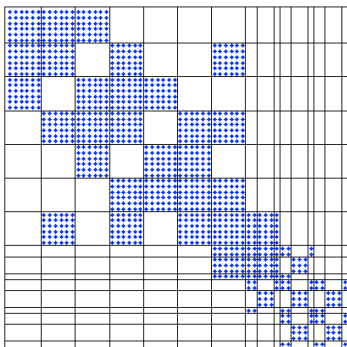

Non-zero entry pattern of a block-structured matrix.

INTERACTIVE COUPLING METHODS FOR WIND TURBINE BLADES AND BIO-MEDICAL APPLICATIONS.

PROJECT AIM

The project focuses on the aerodynamic optimization of turbine blades. The simulation approach builds on viscous-inviscid boundary-layer interaction. The numerical coupling between boundary layer and inviscid outer flow is similar to that used in our bio-medical project.

PROGRESS

The wind energy project (with ECN) has successfully been finished with a PhD defense by Henny Bijleveld. Herein she studies viscous-inviscid interaction methods for separated aerodynamic boundary layers along turbine blades. Similar interaction methods are used in bio-medical applications, like cardio-vascular flow in elastic blood vessels (arteria carotis, with UMCG), featuring two-way fluid-structure interaction and 0D-3D model coupling. Also, in cooperation with UMCG and INCAS3, a mathematical model for the two-way coupling between the middle ear and the inner ear has been developed.

DISSERTATIONS

1. HA Bijleveld, A quasi-simultaneous interaction method for the determination of aerodynamics forces on wind turbine blades. PhD thesis, University of Groningen, 21 June 2013, 182 pages.

SCIENTIFIC PUBLICATIONS

-

PROJECT LEADERS

AEP Veldman

RESEARCH THEME

Mathematical and computational methods for fluid flow analysis

PARTICIPANTS

H HA Bijleveld, G Rozema, O Heslinga, P vHengel (INCAS3)

COOPERATIONS

ECN, INCAS3

FUNDED

| | |
|--------------|------|
| ECN | |
| University | 10 % |
| FOM | - |
| STW | - |
| NWO Other | - |
| Industry | - |
| TNO | - |
| GTI | 90 % |
| EU | - |
| Scholarships | - |

START OF THE PROJECT

2008

INFORMATION

AEP Veldman

050 363 3939

a.e.p.veldman@rug.nl

www.math.rug.nl/~veldman

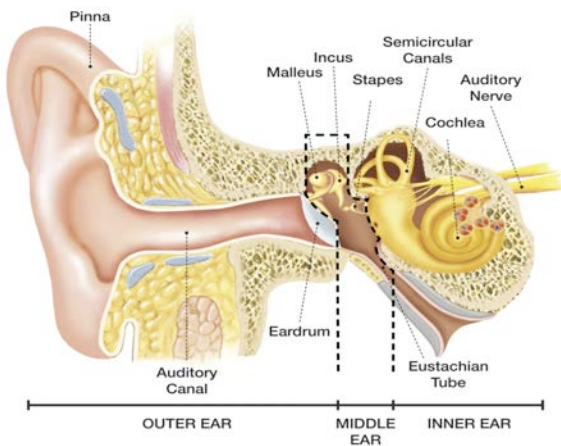

The interaction between middle ear and inner ear is studied with quasi-simultaneous coupling methods.



Prof.dr.ir. J.L. van Leeuwen

The current main theme of the Experimental Zoology Group is the biomechanics and development of the locomotion and feeding system in fish and other vertebrates (such as amphibians, reptiles and horses), in an evolutionary perspective and in relation to animal welfare. Mechanisms of development, growth and adaptation are studied at several levels of structural organisation, from molecules to ecosystem. This integrates several research lines such as (1) architectural organisation and remodelling of muscle and skeletons in larval and juvenile fish, (2) biofluid dynamics of swimming in larval fish and flight in birds, (3) effects of training on growth of the muscular and skeletal system, signified by for instance molecular expression patterns, and (4) structural development and function of the equilibrium system. We have also an evolutionary mechanics line of research that relates form and function at the organismal level to the actual niches and adaptive radiation in the natural environment.

THE FOLLOWING RESEARCH LINES ARE CARRIED OUT

1. Biomechanics of development in teleost fish
2. Biofluid dynamics of swimming and flight
3. Evolutionary mechanics of live bearing fish
4. Biomechanics of tongues and tentacles
5. Biophysics of sensory systems
6. Biofluid dynamics of filter feeding in invertebrates



Prof.dr. LRM Maas

Research in this theme focuses on the interactions between the water motion, sediment transport and bottom changes in coastal seas and estuaries. Both sandy and mud-dominated coastal systems are investigated. The following approaches are used to gain more understanding of hydrodynamic and morphodynamic processes: collection and analysis of field observations, simulations with complex numerical models and interpretation of these results, development and analysis of idealized mathematical models.

OBSERVATIONAL STUDY OF THE EQUATORIAL BOUNDARY LAYER

PROJECT AIM

Observations show that ocean dynamics distinctly differs in a narrow zone of about ± 2 degree near the equator compared to off-equatorial regions. Geometric focusing of internal waves, and strictly equatorial features (i.e. horizontal component of Coriolis force), traditionally neglected, might have an important effect on the dynamics of the low latitudes, which we aim to illuminate by (1) 3D ray tracing study of internal wave beams in fully enclosed (geophysical) domains; (2) a set of ad hoc observations in the West Equatorial Atlantic Ocean; (3) development of a consistent theoretical framework for interpretation of linear equatorial dynamics.

PROGRESS

A 3D internal wave ray tracing algorithm has been developed and applied to the spherical shell geometry in order to investigate the wave behavior in fully enclosed (geophysical) domains. The occurrence of internal wave attractors seems to dominate in the equatorial band, where they are hypothesized to play a role in the real Ocean via wave-wave and wave-main flow interactions. In situ data are currently under analysis in order to verify this hypothesis and to characterize the intermediate-to-deep equatorial wave and current field. The same 3D ray tracing algorithm has been applied to the full sphere geometry, where analytical solutions for the internal wave problem are known, and results from the two methods compared.

DISSERTATIONS

-

SCIENTIFIC PUBLICATIONS

1. A. Rabitti and L. R. M. Maas. Meridional trapping and zonal propagation of inertial waves in a rotating fluid shell. *Journal of Fluid Mechanics*, 729:445-470, 2013.

PROJECT LEADERS

LRM Maas

RESEARCH THEME

Complex dynamics of fluids

PARTICIPANTS

T Gerkema, H van Haren, A Rabitti

COOPERATIONS

NIOZ, UU

FUNDED

| | |
|--------------|-------|
| NWO | |
| University | - |
| FOM | - |
| STW | - |
| NWO Other | 100 % |
| Industry | - |
| TNO | - |
| GTI | - |
| EU | - |
| Scholarships | - |

START OF THE PROJECT

2009

INFORMATION

LRM Maas

0222 369419

leo.maas@nioz.nl

www.nioz.nl

DYNAMICAL OCEANOGRAPHY AT IMAU



Prof.dr.ir. HA Dijkstra

In my group, we study the role of the ocean circulation in the variability of the climate system and the processes controlling the large-scale ocean circulation.

Focus of work in on the path changes of ocean western boundary currents (such as the Gulf Stream in the Atlantic, the Kuroshio in the Pacific and the Agulhas near South Africa), the El Nino/Southern Oscillation phenomenon in the Pacific and the North Atlantic Multidecadal variability. Both theory development and (high-resolution) model simulation are used to understand these phenomena and our favorite framework to analyse the complex behavior of ocean flows is that provided by stochastic dynamical systems theory.

PREDICTABILITY OF KUROSHIO CURRENT PATH TRANSITIONS

PROJECT AIM

Our objectives are (i) to develop a unifying theory of the Kuroshio path variability, (ii) to assess the decadal time scale predictability of these path transitions, (iii) to determine the effects of the large-scale barotropic instabilities, meso-scale eddies and wind-stress variations on this predictability and (iv) to study of impact of different observational data on the prediction skill of the models used.

PROGRESS

Much progress has been obtained in solving the stochastic partial differential equations for the single layer problem by using a Dynamical Orthogonal Field formulation [1]. The physics of error growth on the Kuroshio variability has been studied using the Conditional Nonlinear Optimal Perturbation approach [2,3]. Transition between paths of the Kuroshio have been studied using a network approach [4].

DISSERTATIONS

-

SCIENTIFIC PUBLICATIONS

1. T. Sapsis and H. A. Dijkstra, Interaction of additive noise and nonlinear dynamics in the double-gyre wind-driven ocean circulation., *J. Phys. Oceanography*, 43, 366-381, (2013).
2. Wang. Q., Mu Mu and H. A. Dijkstra, The similarity between optimal precursor and optimally growing initial error in prediction of Kuroshio large meander and its application to targeted observation *J. Geophysical Research Oceans*, 118, 869–884, (2013).
3. Wang. Q., Mu Mu and H. A. Dijkstra, Effects of nonlinear physical processes on optimal error growth in predictability experiments of the Kuroshio Large Meander. *J. Geophysical Research Oceans*, 118, 6425–6436 (2013).

PROJECT LEADERS

HA Dijkstra

RESEARCH THEME

Complex dynamics of fluids

PARTICIPANTS

J Viebahn

COOPERATIONS

Dr. Fred Wubs (RUG), Dr. T. Sapsis (Courant Institute, NY, USA), Prof.

Mu Mu (IOCAS, Qingdao, China)

Prof. S. Pierini (Univ. Naples, Naples, Italy)

FUNDED

NWO-EW (COMPLEXITY)

University -

FOM -

STW -

NWO Other 100 %

Industry -

TNO -

GTI -

EU -

Scholarships -

START OF THE PROJECT

2011

INFORMATION

HA Dijkstra

H.A.Dijkstra@uu.nl

WHO & WHERE



Mechanical Engineering - Mekelweg 2 - 2628 CD Delft

- ◆ Prof.dr.ir. J Westerweel 015 278 6887 j.westerweel@tudelft.nl
- Prof.dr. DJEM Roekaerts 015 278 2470 d.j.e.m.roekaerts@tudelft.nl
- Prof.dr.ir. RAWM Henkes 015 278 1323 r.a.w.m.henkes@tudelft.nl
- Prof.dr. JCR Hunt 015 278 2904 jcrh@cpom.ucl.ac.uk
- Prof.dr.ir. G Ooms 015 278 1176 g.ooms@tudelft.nl
- Prof.dr.ir. B Eckhardt 015 278 2904 bruno.eckhardt@physik.uni-marburg.de
- ◆ Prof.dr.ir. BJ Boersma 015 278 7979 b.j.boersma@tudelft.nl

Maritime Engineering - Mekelweg 2 - 2628 CD Delft

- ◆ Prof.dr.ir. RHM Huijsmans 015 278 2889 r.h.m.huijsmans@tudelft.nl
- Prof.dr.ir. TJC van Terwisga 015 278 6860 t.v.terwisga@tudelft.nl
- ◆ Prof.dr.ir. C van Rhee 015 278 3973 c.vanrhee@tudelft.nl

Applied Mathematics - Mekelweg 4 - 2628 CD Delft

- ◆ Prof.dr.ir. C Vuik 015 278 5530 c.vuik@tudelft.nl
- Prof.dr.ir. P Wesseling 015 278 3631 p.wesseling@tudelft.nl
- ◆ Prof.dr.ir. AW Heemink 015 278 5813 a.w.heemink@tudelft.nl

Chemical Engineering - Julianalaan 136 - 2628 BW Delft

- ◆ Prof.dr.ir. CR Kleijn 015 278 2835 c.r.kleijn@tudelft.nl
- Prof.dr. RF Mudde 015 278 2834 r.f.mudde@tudelft.nl
- Prof.dr.ir. HEA van den Akker 015 278 5000 h.e.a.vandenakker@tudelft.nl
- Prof.dr.ir. S Sundaresan 015 278 5000 sundar@princeton.edu
- ◆ Prof.dr.ir. MT Kreutzer 015 278 9084 m.t.kreutzer@tudelft.nl

Radiation Science and Technology - Mekelweg 15 - 2629 JB Delft

- ◆ Prof.dr.ir. THJJ van der Hagen/Rohde 015 278 2105 t.h.j.j.vanderhagen@tudelft.nl

Aerospace Engineering - Kluyverweg 2 - 2600 GB Delft

- ◆ Prof.dr.ir. H Bijl 015 278 5373 h.bijl@tudelft.nl
- Prof.dr.ir. F Scarano 015 278 9111 f.scarano@tudelft.nl
- Prof.dr.ir. PG Bakker 015 278 5907 p.g.bakker@tudelft.nl

Civil Engineering and Geosciences - Stevinweg 1 - 2628 CN Delft

- ◆ Prof.dr.ir. GS Stelling 015 278 5426 g.s.stelling@tudelft.nl
- Prof.dr.ir. WSJ Uijtewaal 015 278 1371 w.s.j.ujtewaal@tudelft.nl
- ◆ Prof.dr. HJJ Jonker 015 278 6157 h.j.j.jonker@tudelft.nl
- Prof.dr. AP Siebesma 015 278 4720 a.p.siebesma@tudelft.nl

Applied Physics

- ◆ Prof.dr.ir. AA Darhuber 040 247 4499 a.a.darhuber@tue.nl
- Prof.dr.ir. JH Snoeijer 040 247 9111 j.h.snoeijer@tue.nl
- Prof.dr.ir. MEH van Dongen 040 247 3194 m.e.h.v.dongen@tue.nl
- ◆ Prof.dr. HJH Clercx 040 247 2680 h.j.h.clercx@tue.nl
- Prof.dr.ir. GJF van Heijst 040 247 2722 g.j.f.v.heijst@tue.nl
- Prof.dr. F Toschi 040 247 3911 f.toschi@tue.nl
- Prof.dr.ir. BJ Geurts 040 247 4285 b.j.geurts@tue.nl
- ◆ Prof.dr.ir. K Kopinga 040 247 4303 k.kopinga@tue.nl
- Prof.dr.ir. OCG Adan 040 247 3398 o.c.g.adan@tue.nl
- ◆ Prof.dr.ir. GMW Kroesen 040 247 4357 g.m.w.kroesen@tue.nl

Mechanical Engineering

- ◆ Prof.dr. LPH de Goey/Bastiaans 040 247 2938 l.p.h.d.goey@tue.nl
- Prof.dr. B Johansson 040 247 3731 b.johansson@tue.nl
- ◆ Prof.dr.ir. JJH Brouwers 040 247 5397 j.j.h.brouwers@tue.nl
- Prof.dr. Golombok 040 247 3664 m.golombok@tue.nl
- ◆ Prof.dr.ir. DMJ Smeulders 040 247 2140 d.m.j.smeulders@tue.nl
- Prof.dr.ir. AA van Steenhoven 040 247 2140 a.a.v.steenhoven@tue.nl
- Prof.dr. HA Zondag 040 247 2719 h.a.zondag@tue.nl
- ◆ Prof.dr.ir. JMJ den Toonder 040 247 5706 j.m.j.d.toonder@tue.nl
- ◆ Prof.dr.ir. EH van Brummelen 040 247 5470 e.h.v.brummelen@tue.nl

Biomedical Engineering

- ◆ Prof.dr.ir. FN van de Vosse 040 247 4218 f.n.v.d.vosse@tue.nl

Mathematics and Computer Science

- ◆ Prof.dr.ir. B Koren 040 247 2080 b.koren@tue.nl
- Prof.dr. WHA Schilders 040 247 5518 w.h.a.schilders@tue.nl
- Prof.dr. F Toschi 040 247 3911 f.toschi@tue.nl
- Prof.dr.ir. CJ van Duijn 040 247 2855 c.j.v.duijn@tue.nl
- Prof.dr. MA Peletier 040 247 2628 m.a.peletier@tue.nl
- Prof.dr. IS Pop 040 247 5516 i.s.pop@tue.nl
- Prof.dr. JJM Slot 040 247 2184 j.j.m.slot@tue.nl

Chemical Engineering and Chemistry

- ◆ Prof.dr.ir. JAM Kuipers 040 247 4158 j.a.m.kuipers@tue.nl
- Prof.dr.ir. M van Sint Annaland 040 247 2241 m.v.sintannaland@tue.nl

Applied Physics

- ◆ Prof.dr. WJ Briels 053 489 2947 w.j.briels@utwente.nl
- ◆ Prof.dr. D Lohse 053 489 8076 d.lohse@utwente.nl
- Prof.dr.ir. D van de Meer 053 489 2387 d.vandermeer@utwente.nl
- Prof.dr.ir. M Versluis 053 489 6824 m.versluis@utwente.nl
- Prof.dr. A Prosperetti 053 489 9111 prosperetti@jhu.edu
- Prof.dr.ir. JF Dijkstra 06 2334 1331 j.f.dijkstra@ziggo.nl
- Prof.dr.ir. L van Wijngaarden 053 489 3086 l.vanwijngaarden@tnw.utwente.nl
- Prof.dr. R Verzicco 053 489 2470 r.verzicco@utwente.nl

◆ Prof.dr. F Mugele 053 489 3094 f.mugele@utwente.nl

Chemical Engineering

◆ Prof.dr.ir. RGH Lammertink 053 489 2063 r.g.h.lammertink@utwente.nl

Mathematical Sciences

◆ Prof.dr.ir. EWC van Groesen 053 489 3413 e.w.c.vangroesen@utwente.nl
◆ Prof.dr.ir. JWW van der Vegt 053 489 5628 j.j.w.vandervegt@utwente.nl
◆ Prof.dr.ir. BJ Geurts 053 489 4125 b.j.geurts@utwente.nl
Prof.dr. JGM Kuerten 053 489 3408 j.g.m.kuerten@utwente.nl
Prof.dr. HJH Clercx 053 489 3408 h.j.h.clercx@utwente.nl

Mechanical Engineering

◆ Prof.dr.ir. HWM Hoeijmakers 053 489 4838 h.w.m.hoeijmakers@utwente.nl
Prof.dr.ir. A Hirschberg 040 247 2163 a.hirschberg@tue.nl
◆ Prof.dr.ir. ThH van der Meer 053 489 2562 t.h.vandermeer@utwente.nl
◆ Prof.dr. S Luding 053 489 4212 s.luding@utwente.nl

Water Engineering and Management

◆ Prof.dr. SJMH Hulscher 053 489 4256 s.j.m.h.hulscher@utwente.nl

RUG | 050 363 9111 | PO Box 800 - 9700 AV Groningen

Mathematics

◆ Prof.dr. AEP Veldman 050 363 3988 veldman@math.rug.nl

WUR | 0317 477 477 | PO Box 9101 - 6701 BH Wageningen

Experimental Zoology

◆ Prof.dr.ir. JL van Leeuwen 0317 482267 johan.vanleeuwen@wur.nl

UU | 030 253 9111 | PO Box 80125 - 3508 TC Utrecht

Physics and Astronomy

◆ Prof.dr. LRM Maas 0222 369 419 maas@nioz.nl
◆ Prof.dr.ir. HA Dijkstra 030 253 5441 h.a.dijkstra@uu.nl

Board of Directors

| | | |
|---|--------------|-----------------------------|
| Prof.dr.ir. G Lodewijks (TUD, Chairman) | 015 278 9111 | g.lodewijks@tudelft.nl |
| Ir. AJ Dalhuijsen (VSL) | 015 269 1500 | adalhuijsen@vsl.nl |
| Prof.dr.ir. CR Kleijn (TUD) | 015 278 2835 | c.r.kleijn@tudelft.nl |
| Prof.dr.ir. JJW van der Vegt (UT) | 053 489 5628 | j.j.w.vandervegt@utwente.nl |
| Prof.dr.ir. GMW Kroesen (TUE) | 040 247 4357 | g.m.w.kroesen@tue.nl |

Management Team

| | | |
|---------------------------------|--------------|-------------------------|
| Prof.dr.ir. GJ van Heijst (TUE) | 040 247 2722 | g.j.f.v.heijst@tue.nl |
| Prof.dr. D Lohse (UT) | 053 489 8076 | d.lohse@utwente.nl |
| Prof.dr.ir. J Westerweel (TUD) | 015 278 6887 | j.westerweel@tudelft.nl |

Industrial Board

| | | |
|---|--------------|--|
| Dr.ir. J Baltussen (AKZO-Nobel) | 026 366 1479 | joop.baltussen@akzonobel-chemicals.com |
| Ir. A van Berkel (TNO Science & Industry) | 055 549 3759 | arij.vanberkel@tno.nl |
| Ir. AJ Dalhuijsen (VSL) | 015 269 1500 | adalhuijsen@vsl.nl |
| Dr. E Pelssers (Philips Research) | 06 40326208 | eduard.pelssers@philips.com |
| Dr. RPJ Duursma (Tatasteel) | 0251 492 363 | rene.duursma@tatasteel.com |
| Ir. A van Garrel (ECN) | 0224 564170 | vangarrel@ecn.nl |
| Ir. J Gonzalez del Amo (ESA/ESTEC) | 071 565 4781 | jose.gonzalez.del.amo@esa.int |
| Ir. G Hommersom (Dow Benelux) | 0115 67 4102 | ghommersom@dow.com |
| Dr.ir. J Janssen (Unilever) | 010 460 6324 | jo.janssen@unilever.com |
| Dr.ir. M Veenman (DSM) | 046 476 1240 | maurice.veenman@dsm.com |
| Ir. JJ Meerman (Teijin Aramid) | 088 268 9367 | hans.meerman@teijinaramid.com |
| Prof.dr.ir. AE Mynett (WL) | 015 285 8580 | a.mynett@unesco-ihe.org |
| Dr. B Oskam (NLR) | 020 511 3357 | oskam@nlr.nl |
| Dr.ir. HJ Prins (Marin) | 0317 493 405 | h.j.prins@marin.nl |
| Ir. H Reinten (Oce) | 077 359 4061 | hans.reinten@oce.com |
| Ir. M Riepen (ASML) | 040 268 3000 | michel.riepen@asml.nl |
| Ir. G Saccoccia (ESA/ESTEC) | 071 565 4781 | giorgio.saccoccia@esa.int |
| Ir. P Veenstra (Shell) | 020 630 3384 | peter.veenstra@shell.com |
| Ir. Veraar (TNO Defence and Safety) | 015 284 3395 | ronald.veraar@tno.nl |
| Dr.ir. FC Visser (Flowserve) | 076 502 8311 | fvisser@flowserve.com |
| Ir. H Vos (TNO Science & Industry) | 015 269 2311 | hugo.vos@tno.nl |
| Dr.ir. B Vreman (AKZO-Nobel) | 026 366 9440 | bert.vreman@akzonobel.com |
| Dr. J Longo (ESA/ESTEC) | 071 565 6662 | jose.longo@esa.int |
| Dr.ir. J van 't Westeinde (Deltares) | 015 278 3210 | jos.vantwesteinde@deltares.nl |
| Ir. M Roest (VORTECH) | 015 285 0127 | mark.roest@vortech.nl |

PhD Students Contact Group

TUD

| | | |
|-----------------|--------------|-----------------------------|
| AJ Greidanus | 015 278 9111 | a.j.greidanus@tudelft.nl |
| M Olivero | 015 278 9479 | m.olivero@tudelft.nl |
| JSB van Zwieten | 015 278 9111 | j.s.b.vanzwieten@tudelft.nl |
| PB Smit | 015 278 9111 | p.b.smit@tudelft.nl |
| X Yang | 015 278 9111 | xiaogang.yang@tudelft.nl |
| D Violato | 015 278 5902 | d.violato@tudelft.nl |

TUE

| | | |
|---------------|--------------|------------------------|
| HM Slagter | 040 247 3685 | h.m.slagter@tue.nl |
| RPC Zegers | 040 247 5689 | r.p.c.zegers@tue.nl |
| CWJ Berendsen | 040 247 9111 | c.w.j.berendsen@tue.nl |

UT

| | | |
|--------------|--------------|-------------------------------|
| B Bera | 053 489 9111 | b.bera@utwente.nl |
| H Gelderblom | 053 489 9111 | h.gelderblom@tnw.utwente.nl |
| HJJ Staat | 053 489 9111 | h.j.j.staat@utwente.nl |
| W Kranenburg | 053 489 2959 | w.m.kranenburg@ctw.utwente.nl |
| BJ Konijn | 053 489 9111 | b.j.konijn@utwente.nl |
| AA Verbeek | 053 489 2507 | a.a.verbeek@utwente.nl |

RUG

| | | |
|--------------------|--------------|-----------------------------|
| HJL van der Heiden | 050 363 3970 | h.j.l.van.der.heiden@rug.nl |
|--------------------|--------------|-----------------------------|

JM Burgerscentrum (the Netherlands)

| | | |
|---|--------------|-----------------------------|
| Prof.dr.ir. G Ooms, scientific director | 015 278 1176 | g.ooms@tudelft.nl |
| I Hoekstein-Philips, secretariat | 015 278 3216 | jmburgerscentrum@tudelft.nl |

Mekelweg 2
2628 CD Delft

Burgers Program Maryland

James M Wallace, Professor, Dept. of Mechanical Engineering
www.eng.umd.edu/~wallace
Gemstone Program Director
www.gemstone.umd.edu/
Chair, Burgers Program for Fluid Dynamics
www.burgers.umd.edu/
T 301 314 6695
F 301 314 8469
E wallace@eng.umd.edu



JMBC ANNUAL REPORT & RESEARCH PROGRAMME
2013-2014