

2014

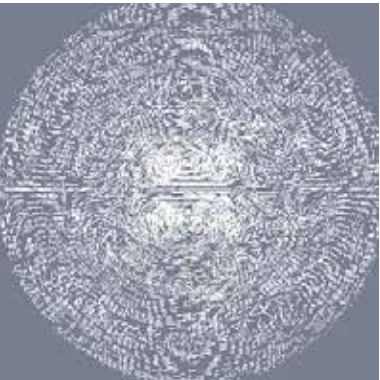

2015

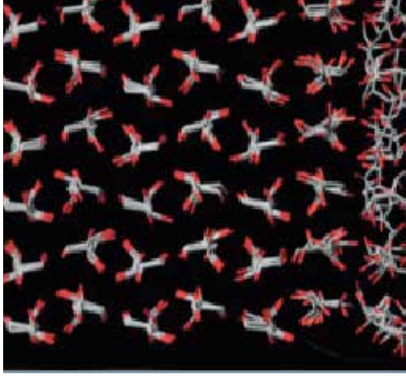
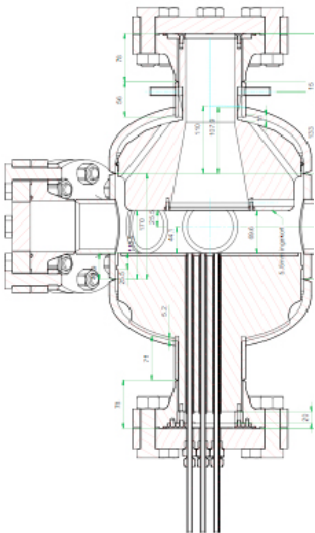

ANNUAL REPORT & RESEARCH PROGRAMME

ANNUAL REPORT & RESEARCH PROGRAMME 2014-2015

JM Burgerscentrum
Research School for Fluid Mechanics

TUD, TUE, UT, RUG, WUR, UU

© June 2015, JM Burgerscentrum

All rights reserved. No part of this publication may be reproduced in any form by print, photoprint, microfilm or any other means without written permission of the rightful claimant(s). This restriction concerns the entire publication or any part of it.

CORRESPONDENCE FOR REPRODUCTION

JM Burgerscentrum
Attn. Mrs. IJLM Hoekstein-Philips
Mekelweg 2
2628 CD Delft
The Netherlands
+31 (0)15 278 3216
jmburgerscentrum@tudelft.nl
www.jmburgerscentrum.nl

Burgers Program for Fluid Dynamics (University of Maryland, USA)
www.enme.umd.edu/burgers/

Contributions of the participating groups, Industrial Board and Contactgroups. Final editing : Prof.dr.ir. GJF van Heijst and Mrs. IJLM Hoekstein-Philips of the JM Burgerscentrum.

Design and lay-out : IJLM Hoekstein-Philips
Printed by : NIVO, Delft

PREFACE



Prof.dr.ir. G Lodewijks
Chairman of the JMBC Board



Prof.dr.ir. GJF van Heijst
Scientific Director

This annual report of the J.M. Burgerscentrum provides an overview of the activities of our research school during the last year (2014). The core of the report consists of the description of the research projects, carried out by the JMBC groups. In each report the relevant information (title, theme, staff involved, project aim, achievements, publications, funding source, application, etc.) is given. As usual, a number of research highlights are presented. The Annual Report also provides general information about the research school, such as its goals, its organization, and its relation with industries and technological institutes.

The number of PhD projects carried out by the JMBC groups is still quite large (about 300). Although the sponsoring of such projects directly via the universities has become almost non-existing, the financing of projects via NWO (in particular FOM and STW) and via industries and technological institutes remains at a high level. Sponsoring of projects via the European Research Council is increasing. Finding funds for our PhD projects remains an important task for all JMBC groups.

The JMBC course programme for the academic year 2014 – 2015 contains the following courses: 'PIV', 'Compressible flows', 'CFD 2', 'Geophysical Fluid Dynamics', 'Particle Technology' en 'Capillarity-driven micro-fluid mechanics', while courses on 'Particle-based modeling techniques' en 'Soft and granular matter' are planned for the next year. These courses are organised in order to give the JMBC PhD students the opportunity to deepen their knowledge in various aspects of fluid dynamics, but also to widen their perspective and give them an overview of the wide field of fluid dynamics. It is therefore recommended for our PhD students to take the opportunity and to participate in these courses.

The activities of the JMBC continue to ensure that the Dutch fluid mechanics field is a lively and well-connected community, with numerous mutual appointments at collaborating groups and collaborative research projects in which multiple JMBC groups participate. The JMBC contact groups continue to be an important instrument for cohesion. These contact groups stimulate interaction and collaboration between researchers, developers, and users. This is done through organizing regular meetings aimed at getting to know each other's activities and learn about developments and applications. Another important instrument to maintain the coherence throughout the research school is the annual Burgersdag for all scientists involved in the JMBC and for many fluid-mechanics experts from industry, TNO and technological institutes. In January 2014 the Burgersdag attracted a large number of participants (approximately 250).

On 4 July 2014 a joint workshop "Controlling multiphase flow" was organized by the JMBC together with the Institute for Sustainable Process Technology (ISPT) and FOM. This workshop took place in Amsterdam, kindly hosted by the Shell Technology Centre Amsterdam. The objective of this JMBC-ISPT-FOM workshop was to exchange knowledge on controlling multiphase flow between researchers from industry and academia and to provide an opportunity for networking. Besides, the discussions during the workshop were meant as important input for a position paper on a possible collaborative research programme in the field of multiphase flow. The workshop was well attended, with approximately 100 participants from industry and university groups. A small committee is now preparing a position paper.

In 2014 one new group was admitted to the Burgerscentrum: Prof. Karin Schroen and her group 'Food and Bioprocess Engineering' at Wageningen University became a member of the JMBC.

For admission of a new group, we follow a standard procedure. The group leader of the group that wishes to participate needs to submit a written motivation, a research plan and CVs of the staff members involved. Based on this application the scientific director asks a number of professors in the JMBC for advice. The application and the advice are then sent to the board of the JMBC, which takes the final decision.

Per 1 July 2014 Prof. Gijs Ooms stepped down as scientific director of the Burgerscentrum, after having served in this position for 17 years. He will be succeeded by Prof. GertJan van Heijst, who has his main affiliation at TU/e, but who will be appointed part-time at TU Delft. Prof. Gijs Ooms served the JMBC for a long time, and his name has become more or less equivalent with the Burgerscentrum. During the 17 years of his directorship, the Burgerscentrum has grown from a school with approximately 80 PhD students to its present size, with more than 300 participating PhD students and postdocs. The organisation of the JMBC has always been lean and efficient, mainly due to the approach taken by Prof. Ooms. His leadership style is greatly appreciated by all participant staff of the Burgerscentrum. At the occasion of his end of term, a special farewell session will be held at the Burgersdag 2015, which will take place at TU Delft.

Due to the enthusiasm and the combined knowledge, skills and facilities of the participating research groups, the JMBC remains to be a very stimulating, multidisciplinary environment for advanced research in fluid mechanics and for the education of talented graduate and postgraduate students. The board and the management team of the JMBC highly value the large effort of the staff of the JMBC in reaching the goals of the research school.

Prof.dr.ir G. Lodewijks
Chairman of the JMBC-Board

Prof.dr.ir. GJF van Heijst
Scientific Director

CONTENTS



CONTENTS

ORGANISATION

| | |
|----|--|
| 13 | Introduction |
| 15 | Participating universities and groups |
| 18 | Industrial Board |
| 19 | Contactgroup “Multiphase Flow” |
| 19 | Contactgroup “Computational Fluid Dynamics (CFD)” |
| 19 | Contactgroup “Combustion” |
| 20 | Contactgroup “Lattice-Boltzmann techniques” |
| 21 | Contactgroup “Turbulence” |
| 21 | Contactgroup “Experimental Techniques” |
| 22 | Contactgroup “Biological Fluid Mechanics” |
| 23 | Contactgroup “Microfluidics” |
| 23 | Burgers Program for Fluid Dynamics at the University of Maryland |

HIGHLIGHTS

| | |
|----|---|
| 27 | Scalar transport in liquid fluidization <i>J Derksen (TUD)</i> |
| 29 | Bouncing on thin air <i>J de Ruiter, R Lagraauw, D van den Ende and F Mugele (UT)</i> |
| 31 | Molecular modeling of sugar alcohols as seasonal heat storage materials <i>H. Zhang, S.V. Nedeia, C.C.M. Rindt, D.M.J. Smeulders (TUE)</i> |
| 33 | Higher flame speed with fractal-grid-generated turbulence <i>AA Verbeek, BJ Geurts, TH van der Meer (UT)</i> |

RESEARCH

| | |
|----|---|
| 37 | Introduction |
| 37 | Description of the research themes |
| 39 | Review of progress in research projects |

TUD

| | |
|-----|---|
| 41 | Fluid Mechanics |
| 73 | Marine Technology |
| 75 | Dredging Engineering |
| 81 | Numerical Analysis |
| 97 | Mathematical Physics |
| 101 | Transport Phenomena |
| 125 | Product and Process Engineering |
| 135 | Nuclear Energy and Radiation Applications |
| 139 | Aerodynamics |
| 155 | Environmental Fluid Mechanics |
| 167 | Geoscience and Remote Sensing |

| | |
|---|-----|
| TUE | |
| Mesoscopic Transport Phenomena | 177 |
| Vortex Dynamics and Turbulence | 187 |
| Transport in Permeable Media | 213 |
| Elementary Processes in Gas Discharges | 221 |
| Combustion Technology | 225 |
| Process Technology | 243 |
| Energy Technology | 251 |
| Microsystems | 269 |
| Multiscale Engineering Fluid Dynamics | 281 |
| Cardiovascular Biomechanics | 285 |
| Centre for Analysis, Scientific Computing and Applications (CASA) | 291 |
| Applied Analysis | 301 |
| Multiphase Reactors Group | 307 |
| UT | |
| Computational Biophysics | 335 |
| Physics of Fluids | 339 |
| Physics of Complex Fluids | 357 |
| Soft matter, Fluidics and Interfaces | 365 |
| Applied Analysis & Mathematical Physics (AAMP) | 371 |
| Mathematics of Computational Science | 373 |
| Multiscale Modeling and Simulation | 379 |
| Engineering Fluid Dynamics | 385 |
| Thermal Engineering | 405 |
| Multiscale Mechanics | 413 |
| Water Engineering and Management | 427 |
| RUG | |
| Computational Mechanics and Numerical Mathematics | 439 |
| WUR | |
| Experimental Zoology Group | 445 |
| Agrotechnology and Food Sciences | 449 |
| UU | |
| Institute for Marine and Atmospheric Reserach Utrecht (IMAU) | 451 |
| Dynamical Oceanography at IMAU | 453 |
| WHO AND WHERE | |
| Participating groups and project leaders | 457 |
| JMBC Board of Directors | 460 |
| Management Team | 460 |
| Industrial Board | 460 |
| PhD students Contact Group | 461 |
| JM Burgerscentrum (The Netherlands) | 461 |
| Burgers Program for Fluid Dynamics (University of Maryland, USA) | 461 |

ORGANISATION



ORGANISATION

The JM Burgerscentrum (JMBC) is the national research school for fluid mechanics in The Netherlands. Delft University of Technology acts as the coordinating university. The main goals of the JMBC are:

- Stimulation of co-operation of the participating groups with respect to their research efforts. The JMBC aims at being one of the leading institutes for fluid mechanics in the world.
- Organization of advanced courses for PhD-students. These courses are also attended by researchers from industries and technological institutes.
- Co-operation with industries and technological institutes. The aim is to promote the use of up-to-date knowledge on fluid mechanics for solving practical problems.
- Strengthen the contacts between Dutch fluid mechanics research groups at universities and the international fluid mechanics community.

About 60 professors with their groups participate in the JMBC. These groups are located at Delft University of Technology, Eindhoven University of Technology, the University of Twente, the University of Groningen, Wageningen University and Utrecht University. These fluid-dynamics groups are based in different departments, and in different disciplines: Civil Engineering; Mechanical Engineering, Maritime Technology, (Applied) Physics, Aerospace Engineering, Applied Mathematics, Chemical Technology, Biology, and Physical Oceanography. The professors with their senior staff form the Council of Project Leaders, which meets regularly. At this moment, approximately 300 PhD-students are registered as participants of the JMBC.

The JMBC has a scientific director who is responsible for the management of the research school; he is assisted by the JMBC secretary. Three times per year the scientific director justifies his actions to the Board of the JMBC, and asks the Board for advice with respect to proposed new activities. He is also assisted by the Management Team, which consists of the local directors from Delft University of Technology, Eindhoven University of Technology (also representing the groups at the University of Wageningen and Utrecht University) and the University of Twente (also representing the group at the University of Groningen).

The research projects carried out by the JMBC-groups have been arranged in a number of research themes. The reason for this ordering is to present in each theme a combination of projects which have coherence. The themes are:

- Complex dynamics of fluids
- Complex structures of fluids
- Mathematical and computational methods for fluid flow analysis.

The JM Burgerscentrum has various good contacts with industries and technological institutes in The Netherlands. This connection is formally facilitated by the Industrial Advisory Board, in which Unilever, Tata Steel, Philips, AKZO-Nobel, Teijin Aramid, Shell, DOW Benelux, ASML, DSM, Océ, NLR, NMI/VSL, TNO-Science and Industry, TNO-Defence and Safety, TNO-Oil - and Energy Industry, MARIN, Deltares, KEMA, ESTEC, ECN/ NRG, FlowServe and Vortech participate. The Industrial advisory Board meets regularly with the scientific director to discuss new activities of relevance to industries and technological institutes.

The JMBC research groups have various scientific contacts with research groups in other countries, often in the form of individual collaboration projects, but also in the form of organised networks. This international setting implies joint publications with other researchers from all over the world, and also exchange of staff: external visitors to the JMBC groups and JMBC staff visiting foreign fluid-mechanics groups. The research groups present their work at international conferences and in the form of journal publications. The number of publications from JMBC staff in well-known scientific journals is considerable.

Together with Engineering Mechanics (the Dutch research school on solid mechanics) the JMBC forms the 3TU Research Centre for Fluid & Solid Mechanics. This Research Centre has been recognized as a "centre of excellence" in The Netherlands and has received significant funding by the Dutch Government for stimulating new research areas in fluid and solid mechanics.

The JMBC has attracted top-experts in different fields of fluid mechanics to the JMBC. These experts have been appointed as JMBC-professors or Centre-of-Excellence professor at the three Universities of Technology, mostly financed by the Boards of the Universities of Technology or by the Research Centre for Fluid & Solid Mechanics. They contribute considerably to the achievements of the research school. An important activity of the JMBC is the organisation of the Annual Meeting of the research school (the so-called 'Burgersdag'). In January 2014 about 250 persons (both staff and PhD students + postdocs) attended the meeting. The central theme of the meeting was the research by JMBC PhD-students, which was presented in a number of parallel sessions and in a poster session.

OVERVIEW OF THE CONTRIBUTION OF THE PARTICIPATING GROUPS OF THE JMBC

| University and (sub)faculty | Scientific staff (fte) | Support staff (fte) | PhD students (fte) |
|--|------------------------|---------------------|--------------------|
| TUD | | | |
| Mechanical Engineering | | | |
| J Westerweel, DJEM Roekaerts, RAWM Henkes, JCR Hunt, G Ooms, B Eckhardt..... | 4.4 | 2.0 | 19.2 |
| BJ Boersma..... | 5.7 | 2.0 | 12.0 |
| Maritime Engineering | | | |
| RHM Huijsmans, TJC van Terwisga..... | 1.6 | 0.0 | 8.0 |
| C van Rhee..... | 1.0 | 0.0 | 4.0 |
| Applied Mathematics | | | |
| C Vuik..... | 2.6 | 0.0 | 8.0 |
| AWH Heemink..... | 3.8 | 0.0 | 8.0 |
| Chemical Engineering | | | |
| CR Kleijn, RF Mudde, HEA van den Akker, S Sundaresan, JJ Derksen..... | 5.7 | 3.2 | 14.0 |
| M Kreutzer..... | 2.1 | 0.5 | 6.0 |
| Radiation Science & Techn. | | | |
| THJJ van der Hagen (M Rohde)..... | 2.6 | 2.0 | 1.6 |
| Aerospace Engineering | | | |
| H Bijl, F Scarano..... | 4.0 | 6.0 | 25.6 |
| Civil Eng. & Geosciences | | | |
| AJHM Reniers, JD Pietrzak, WSJ Uijtewaal..... | 1.1 | 2.0 | 1.6 |
| HJJ Jonker, AP Siebesma..... | 2.2 | 1.0 | 9.0 |
| TUE | | | |
| Applied Physics | | | |
| AA Darhuber, J Snoeijer..... | 2.1 | 0.8 | 3.2 |
| HJH Clercx, GJ van Heijst, F Toschi, BJ Geurts..... | 5.0 | - | 9.6 |
| OCG Adan..... | 0.9 | - | 7.2 |
| GWM Kroesen..... | 2.7 | 0.5 | 6.0 |
| Mechanical Engineering | | | |
| RJM Bastiaans, LPH de Goey, B Johansson..... | 1.9 | 4.0 | 17.6 |
| JGM Kuerten, M Golokbok..... | 0.9 | - | 2.4 |
| DMJ Smeulders, AA van Steenhoven, HA Zondag..... | 2.1 | 1.8 | 10.0 |
| JMJ den Toonder..... | 3.1 | - | 5.6 |
| EH van Brummelen..... | 0.7 | - | 0.8 |
| Biomedical Engineering | | | |
| FN van de Vosse..... | 0.2 | - | 3.2 |
| Mathematics and Computer Science | | | |
| B Koren, F Toschi..... | 0.8 | 0.0 | 3.2 |
| CJ van Duijn, JJM Slot..... | 2.4 | - | 3.2 |
| Chemical Eng. & Chemistry | | | |
| JAM Kuipers, M van Sint Annaland..... | 7.0 | 5.0 | 37.0 |

| University and (sub)faculty | Scientific staff (fte) | Support staff (fte) | PhD students (fte) |
|--|------------------------|---------------------|--------------------|
| UT | | | |
| Applied Physics | | | |
| WJ Briels | 2.4 | - | 5.6 |
| D Lohse, D van der Meer, J Snoeijer, M Versluis, J Harting, X Zhang, | | | |
| JF Dijkman, L van Wijngaarden, A Prosperetti, R Verzicco..... | 9.5 | - | 22.8 |
| F Mugele | 9.1 | 3.0 | 10.0 |
| Chemical Engineering | | | |
| RGH Lammertink..... | 1.3 | 1.0 | 6.4 |
| Mathematical Sciences | | | |
| EWC van Groesen..... | 0.5 | - | 3.0 |
| JJW van der Vegt, O Bokhove | 1.5 | - | 5.0 |
| BJ Geurts, JGM Kuerfen, HJH Clercx..... | 1.5 | - | 5.6 |
| Mechanical Engineering | | | |
| CH Venner, HWM Hoeijmakers, A Hirschberg | 2.0 | 2.6 | 7.2 |
| ThH van der Meer | 1.1 | 0.4 | 4.8 |
| S Luding | 3.1 | - | 9.0 |
| Water Engineering & Manag. | | | |
| SJM Hulscher..... | 4.0 | - | 9.6 |
| RUG | | | |
| Mathematics | | | |
| RWCP Verstappen..... | 1.9 | - | 5.6 |
| WUR | | | |
| Experimental Zoology | | | |
| JL van Leeuwen..... | 0.5 | - | 1.5 |
| Agrotechnology & Food Sciences | | | |
| CGPH Schroen..... | 0.3 | - | 0.8 |
| UU | | | |
| Physics and Astronomy | | | |
| LRM Maas | 0.2 | - | 0.8 |
| H Dijkstra | 0.3 | - | 0.8 |

The calculation of fte's is based on: Professor 0,3 fte | Part-time professor 0.1 fte | Associated professor and assistant professor 0,4 fte | post-doc 1,0 fte | Support Staff 1.0 | PhD-student 0,8 fte

OVERVIEW OF UNIVERSITY PARTICIPANTS

| | TUD | TUE | UT | RUG | WUR | UU | Total |
|-----------------|------|------|----|-----|-----|-----|-------|
| Scientific staf | 36.8 | 29.8 | 36 | 1.9 | 0.8 | 0.5 | 105.8 |
| Support staff | 18.7 | 12.1 | 7 | - | - | - | 37.8 |
| PhD-students | 117 | 109 | 89 | 5.6 | 2.3 | 1.6 | 324.5 |

INDUSTRIAL BOARD

It is a privilege to contribute to the Annual Report of the J.M. Burgers Centre (JMBC), the research school for fluid dynamics in The Netherlands, as the new chair of the Industrial Board.

I like to start with applauding Gijs for his exemplary contributions to the fluid flow community, and wishing GertJan success as scientific director of JMBC. I'm looking forward to continue the collaboration.

As can be seen from the list of industrial members, fluid flow is of interest for a wide range of applications. Last year we organised two events with as objective to bring people together and explore developments and directions in the field of fluid flow. 'Numerics for multi-phase flow' focused on the type of numerical models and software platforms which are used and developed, with presentations from industry, universities and institutes, and a few interactive sessions. Learnings will be shared separately. 'Controlling multi-phase flow' addressed multi-phase flow in the context of needs from process industry and its applications and looking at the underlying fundamentals. This workshop was co-hosted by ISPT, FOM and industry, and pioneering as challenges were presented in duo format from industry and universities. As outcome a couple of leads were identified, of which one (emulsions) is presently being worked out in the form of a draft proposal. The draft text is written as a joint effort between companies from the food and oil/gas business. The coming months potential options for further detailing, wider collaboration and funding will be discussed.

As can be seen from both events, we are seeking interaction between industries, universities, and institutes, and push for interaction with other disciplines like process engineering, materials, mechanical engineering, etc. The turn-out was beyond expectations, and as such a good indicator and basis to start planning for another event.

Although the number of participants during the well-known Burgers day is high, we are looking for options to keep this yearly event attractive, also from industrial perspective. Please don't hesitate to connect with JMBC or myself to discuss your ideas.

Addressing the interactions in and around the fluid flow community in The Netherlands is our first priority, however, it is clear that we should also have an open eye for what happens in the larger world and see if and how JMBC can play a role at that stage as well. We will explore collaboration in the technical arena, however, will also not shy away from focused interactions with non-technical groups and leaders.



Dr.ir. P Veenstra
Shell
Chairman of the Industrial Board



Prof.dr.ir. RAWM Henkes
Delft University of Technology



Dr.ir. NG Deen
Eindhoven University of Technology



Prof.dr.ir. RWCP Verstappen
University of Groningen



Prof.dr. DJEM Roekaerts
Delft University of Technology

CONTACTGROUP “MULTIPHASE FLOW”

The objective of the Contactgroup Multiphase Flow is to stimulate interaction and collaboration between researchers, developers, and users in the area of multiphase flow from universities, institutes and industries. This is done through organizing regular meetings (once or twice per year) aimed at getting to know each other's activities and to learn about developments and applications of multiphase flow technology. This will provide a good forum to identify the needs of the users and to bring to the attention new possibilities for applying multiphase flow research results. Industry, a research institute or a university in turn act as host of the meetings. The program consists of a series of lectures on a specific theme and a visit of some of the local multiphase flow facilities.

Examples of themes covered are: dynamic multiphase flows, multiphase flows with surface-active agents, and innovation with multiphase flow. On 5th September 2014 a very successful one-day meeting was held at DNV GL in Groningen, with the theme “Multiphase Flow Measurements”. There were 7 technical presentations and a visit to the new pressurized multiphase flow test facility.

CONTACTGROUP “COMPUTATIONAL FLUID DYNAMICS (CFD)”

Computational Fluid Dynamics (CFD) forms a rapidly advancing discipline that studies flow phenomena in science and engineering by means of computer simulation. Its basic principles are presented in a series of well-attended JMBC PhD courses: CFD 1, 2, and 3. The aim of the contactgroup is to exchange knowledge and experience in developing and applying CFD methods. Especially, PhD students will be given the opportunity to present their latest research achievements. Because Arthur Veldman has officially retired, the chairmanship of the contactgroup will be taken over by Roel Verstappen. After the succesfull meeting on free-surface flows in December 2013, plans are being made for a meeting on DNS and LES methods for turbulent flow.

CONTACTGROUP “COMBUSTION”

The JMBC has groups active in combustion research at the universities of Delft, Eindhoven, Groningen, and Twente. The contactgroup combustion is an informal network between these groups. These groups also participate in the STW-platform ‘Clean and Efficient Combustion’ to enhance the mutual collaboration between the different groups and to interest more industrial parties for the fundamental research on combustion. The annual COMBURA symposium was organized for the 13th time. It took place in Soesterberg on October 8 and 9. This symposium is the major annual event in the Netherlands for exchange of information on combustion research and its applications. It is a joint initiative of the STW-platform, the Nederlandse Vlam Vereniging NVV (Dutch section of the International Flame Research Foundation IFRF) and the Dutch section of the Combustion Institute. On the first day the members meeting of the NVV was held. As new chairman, succeeding Pepijn Pronk from Tata Steel, Jeroen van Oijen of TU/e was elected. NVV will take the lead in the organization of the Combura Symposium in 2015. On the second day keynote lectures were held by Jörg Gigler, director of the TKI Gas, and by Philip

de Goey of TU/e. A special session was devoted to the highlights of the eight research projects within the STW program on Clean Combustion Concepts (CCC), all of which are executed by research groups of the JM Burgers Centre. Other sessions were held on 'Liquid fuel combustion', 'Applied combustion', 'Combustion modeling'. On the program was also a presentation by the winner of the 2014 NVV Combustion Award for the best Master Thesis of the year in the area of combustion: Maikel van der Steen, student of TU Delft, gave a presentation on his MSc project titled 'Flame-wall interaction of a flame jet impinging normally on a cooled cylinder'.

CONTACTGROUP "LATTICE-BOLTZMANN TECHNIQUES"

The JMBC contact group on "Lattice-Boltzmann techniques" was first established in 2002. The Lattice-Boltzmann schemes can be seen both as flexible and efficient solvers for macroscopic fluid equations or as particle-based simulation techniques which make close contact with the kinetic theory of gases. It is this last feature that allowed, in recent years, the partial disclosing of the huge potential of the method. The Lattice Boltzmann method has demonstrated great accuracy and performance in dealing with multiphase and multicomponent flows, from laminar to turbulent, in presence of simple or complex boundary conditions. The contact group promotes the organisation of educational and research events.



Prof.dr. F Toschi
Eindhoven University of Technology



Prof.dr.ir. BJ Boersma
Delft University of Technology



Dr.ir. WP Breugem
Delft University of Technology



Dr. C Sun
University of Twente



Prof.dr. M Versluis
University of Twente

CONTACTGROUP “TURBULENCE”

The contactgroup Turbulence organizes yearly meetings between researchers of the JM Burgerscentrum active in the field of turbulence with the aim to strengthen contact between them and to exchange results and experience. PhD students and other researchers are given the opportunity to present their results in an informal setting that promotes discussion.

Researchers that are not affiliated to the JM Burgerscentrum are also welcome to participate in our meetings. If you want to be invited for our meetings, please send an email to Wim-Paul Breugem at w.p.breugem@tudelft.nl with subject `jmbc turbulence mailing list`. Past meetings of our contactgroup were held at the University of Twente (December 2014), Tata Steel (a joint meeting with the contactgroup Multiphase Flow in May 2013), RuG (April 2012), TU/e (April 2011) and TU Delft (June 2010). The next meeting will presumably be held at the TU Delft in May/June 2015. More information on our meetings is available at www.pe.tudelft.nl/~wim/jmbc_turb_contactgroup.

CONTACTGROUP “EXPERIMENTAL TECHNIQUES”

The Contact Group Experimental Techniques forms a platform where experiments and experimental techniques can be discussed and evaluated. The main function of the contact group is to organize meetings in which the practice of experimenting can be discussed. An important contribution of the contact group is the organization of the JMBC course on Experimental Techniques in Fluid Mechanics. The course is very popular among the JMBC members as it gives a broad overview of advanced experimental techniques commonly used in fluid mechanics laboratories. The next course will be held in June 2016 at the University of Twente.

CONTACTGROUP “BIOLOGICAL FLUID MECHANICS”

More and more research is conducted at the border between biology and fluid mechanics. This happens within many disciplines, from physiology (e.g. the interaction between blood flow and vessel walls) to aerodynamics (e.g. flapping flight). However, all deal with the interaction between fluids and a complex, changing geometry. One of the main challenges is to bridge the gaps between physics (esp. fluid mechanics) and medical and health sciences. To stimulate this relatively young field of research and bring together researchers, a new contact group was started in 2006. While the contact group is formally a part of the J.M. Burgerscentrum, the participation from researchers from non-affiliated universities, medical centers and institutes is encouraged. The Bio-Fluid Mechanics course (March 2009: about 40 participants) was jointly supported by the JM Burgers Centre and the ERCOFTAC organization by advertising the course amongst their members, via the website and by some financial means. Topics included: a recap of basics of fluid mechanics, external flows (swimming and flying, interaction of plankton and turbulence), internal flows (microcirculation, hemodynamics in large arteries, flow in flexible tubes, respiratory system, etc.). Examples of relevant experimental techniques, as well as simulation techniques were discussed. In case of a sufficient amount of interest a new course can be planned in the coming period.



Prof.dr.ir. F van de Vosse
Eindhoven University of Technology



Dr.ir. C Poelma
Delft University of Technology



Prof.dr. F Mugele
University of Twente



Prof.dr. J den Toonder
Philips Research
Eindhoven University of Technology



Prof.dr.ir. J Westerweel
Delft University of Technology



Prof.dr. JM Wallace
University of Maryland

CONTACT GROUP “MICROFLUIDICS”

The contact group “Microfluidics” was established in 2005. The purpose of the contact group is to bring together students and postdocs interested in fluid dynamic aspects of microfluidics and give them a forum for presenting their results and exchanging ideas. Topics of interest include wetting and capillarity-driven flows, two-phase flow, drop generation, emulsification, contact line dynamics, flow visualization and measurement techniques. During the 2012 spring meeting of the contact group on May 31st in Eindhoven, 10 PhD students presented their recent progress and discussed their results with colleagues from other groups of the Tu/e, TUD, and UT. The next meeting is planned for late spring in Delft and will be announced to all members of the contact group in due time. Students and researchers who are interested in the activities of the group are invited to contact the organizers of the contact group and have their name added to the mailing list. On April 15-19, members of the contact group organize the JMBC course “Capillarity-driven flows in microfluidics”, which will take place in De Lutte, close to Twente. Participants are invited to apply for the course as usual via the JMBC website.

BURGERS PROGRAM FOR FLUID DYNAMICS AT THE UNIVERSITY OF MARYLAND

Inspired by the intellectual heritage of Johannes M. Burgers, who had a second career at the University of Maryland (1955 - 1981) after his retirement at the Technical University of Delft as Professor of Aero and Hydrodynamics, the mission of the Burgers Program for Fluid Dynamics is to enhance the quality and international visibility of the research and educational programs in fluid dynamics and related areas at the University of Maryland, in partnership with the J.M. Burgerscentrum (JMBC) in The Netherlands. Fluid dynamics, in this context, is viewed to include a broad range of dynamics, from nanoscales to geophysical scales, in simple and complex fluids. The interdisciplinary Burgers Program encompasses over 70 faculty members spread over 22 different units in the College of Computer, Mathematical and Natural Sciences and the A. James Clark School of Engineering. For detailed information go to <http://www.burgers.umd.edu/>.

The establishment of the Burgers Program for Fluid Dynamics was celebrated with an inaugural symposium at the University of Maryland in November 2004. Gijs Ooms, Scientific Director of the JMBC gave a lecture on the life and legacy Burgers on this occasion.

At the second Burgers Symposium in 2005, James Wallace gave a talk celebrating the contributions of Frans T. M. Nieuwstadt, recently deceased Director of the Laboratory for Aero and Hydrodynamics of the Technical University of Delft and a founder of the JMBC. In November 2014 the University of Maryland celebrated the tenth anniversary of the Burgers Program at the eleventh annual Burgers Symposium. Gijs Ooms gave a talk recalling the many fruitful faculty and student exchanges between the JMBC and the Burgers Program.

Burgers Visiting Faculty and Student Exchanges - In 2003 the Burgers Program created a Burgers Visiting Professorship in fluid dynamics. We have been able to attract a number of distinguished professors from universities abroad to spend up to a year at the University of Maryland working with our faculty and their graduate students and post-doctoral fellows. The first (2004-2005) Burgers Visiting Professor was Bruno Eckhardt of the Phillips Universität in Marburg. In 2005-2006 our Burgers Associate Professors were Dr. Sasa Kenjeres of TU Delft and Dr. Serge Simoëns of the Ecole Centrale de Lyon. Since then, our Burgers Visiting Professors have been Jerry Westerweel of TU Delft for three months in 2007, Willem van de Water of the Eindhoven University of Technology for 2 months in 2008, W. van Saarloos of Leiden University for two weeks, also in 2008, W. J. Briels of Twente University for two months in 2010, Marie Farge of the Ecole Normale Supérieure, Paris for one month in 2011, Henk Dijkstra of Utrecht University for two months in 2012 and Ulrike Feudel of the University of Oldenburg for six months in 2013. In addition, quite a number of graduate students from the JMBC have had visits of several months at Maryland with our faculty. Faculty from the University of Maryland are encouraged to spend a sabbatical at one of the Dutch Universities associated with JMBC. Kenneth Kiger, who was a speaker at the Burgersdag 2006, earlier had spent a sabbatical year with the JMBC research group in Delft, and a number of University of Maryland students have attended JMBC workshops.

Burgers Lectureship - We hold an annual Burgers Lecture which is given by a distinguished visitor who comes to the campus for several days or even weeks in November. This is always the keynote lecture at our annual Burgers Symposium, which usually takes place in the week before the annual Division of Fluid Dynamics meeting of the American Physical Society. In 2003 Frans Nieuwstadt, was our lecturer. Since then, Bruno Eckhardt, Charles Meneveau of Johns Hopkins University, Gijs Ooms, Detlef Lohse of Twente University, Wim van Saarloos, Kees Vuik of TU Delft, Wim Briels, Marie Farge, Henk Dijkstra, Ulrike Feudel and Katepalli Sreenivasan of New York University have been our Burgers Lecturers.

Annual Graduate Student/Post-Doctoral Fellow Showcase Symposium - In collaboration with the Center for Applied and Environmental Fluid Mechanics of Johns Hopkins University and the Fluid Dynamics Group at George Washington University, we hold an annual graduate student/post-doctoral fellow showcase symposium in the spring of each year. The venue for the symposium alternates between sites each year. After a keynote address by a faculty member from one of the visiting institutions, students and research associates give short presentations on their research. Members of the fluid dynamics community from around the region are invited to attend the symposium with the hope that the presentations will interest these attendees and create employment opportunities for the presenters. This event was initiated at Johns Hopkins University. The Burgers Program began participating in 2005, and in 2012 the group at the George Washington University joined us.

Research Schools on Fluid Dynamics - This initiative was inaugurated in May 2010. The level of instructions for these schools is aimed somewhat beyond that of a first graduate course in the subject area. The subject of the first Research School was Turbulence. Almost 40 graduate student and post-doc participants from the U.S. and other countries, including nine from the JMBC, attended. Subsequently, another very successful Tutorial School on Granular Flows - From Simulations to Astrophysical Applications was held in June of 2011. In June 2013 a Tutorial School on Data Assimilation in Geoscience was held, and a repeat of the Turbulence School will take place in June of 2015.

Fluid Dynamics Reviews seminars - This seminar series, which has continued for almost fifty years at the University of Maryland, has been incorporated into the Burgers Program. It is supported by the Minta Martin research fund. The format allows for faculty and their students and post-docs from the Burgers Program as well as for visitors to give presentations five or six times per semester. The seminar series has sponsored the visits of a long list of very distinguished speakers over the many years it has been a part of the campus' intellectual life.

HIGHLIGHTS

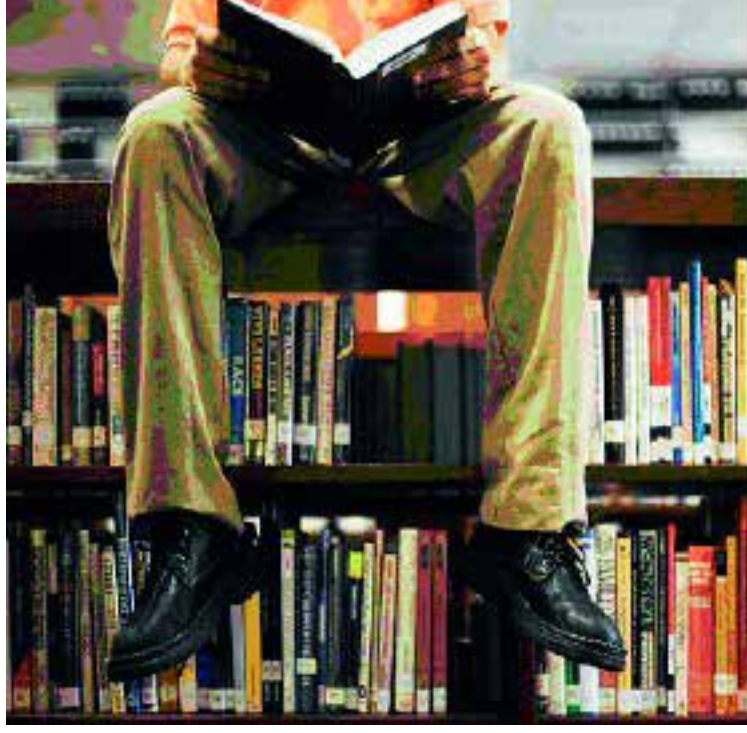

Jos Derksen – Transport Phenomena – ChemE – TU Delft

Next to their rich hydrodynamics [1], sedimenting and fluidized solid-liquid suspensions have many practical applications in industrial processes, e.g. wastewater treatment, crystallization, and leaching, (extraction of minerals from a solids phase). These applications require insight not only in the fluidization dynamics but also in the transport of scalars (chemical agents, heat) in the liquid phase of the suspension, and the exchange of these scalars between solids and liquid. Such transport processes are, obviously, intimately linked to the hydrodynamics of the fluidized suspension.

We perform direct numerical simulations of hydrodynamics and scalar transport in fluidized beds consisting of a Newtonian liquid and spherical solid particles. The simulations are resolved beyond the size of the particles which means that the grid on which the liquid flow is solved is finer than the particle size and that we explicitly impose no-slip conditions on the surfaces of the solid spheres. Hydrodynamic forces and torques on the spheres that result from the flow simulation are used to update particle velocities (translational and rotational) and positions and thus provide updated no-slip boundaries for the liquid. This all creates an intimate and realistic coupling between liquid and solid dynamics. The numerical procedure is based on the lattice-Boltzmann method supplemented with immersed boundaries.

The scalars in the simulations are one-way coupled to the flow dynamics: the scalar concentrations respond to the liquid velocity field, the liquid flow field is not influenced by the scalars. Scalar convection-diffusion equations are solved by means of a finite volume method. Two specific scalar boundary conditions have been considered: (1) passive particles, i.e. particles that do not directly take part in the scalar transport process (in mathematical terms it means $\partial c/\partial n=0$ at solid surfaces); (2) active particles with – as a canonical case – a fixed scalar concentration at the solid surfaces and thus transfer of scalar from solid to liquid (or vice versa). Given the usually high Schmidt numbers in liquids ($Sc=O(1,000)$), specifically the active particle cases require very high resolution due to the thin scalar boundary layers near the solid surfaces. For this we have devised a Coupled Overlapping Domain method [2] where fine spherical grids around each particle communicate with a coarser background grid.

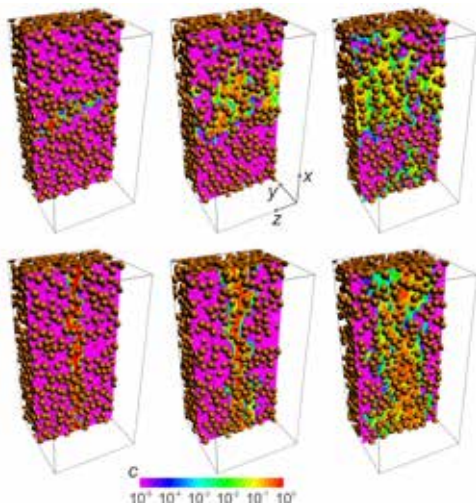

Impressions of scalar spreading at a solids volume fraction of 0.4. Upper row: three instances of scalar that initially was confined to a horizontal slab halfway the domain; bottom row: same for an initially vertical scalar slab. For visibility, the spheres in front of the contours plane are not shown. Note the logarithmic colour scale.

For passive particles, the research focuses on scalar dispersion as a result of the liquid flow fluctuations brought about by the largely erratic particle motion [3]. This dispersion is highly anisotropic with streamwise scalar spreading being one order of magnitude stronger than lateral spreading. This can be qualitatively witnessed in Figure 1. Scalar dispersion coefficients appear to be correlated to particle self-diffusion [3].

Simulations with active particles [2] (see Figure 2 for an impression) have been used to relate overall Sherwood numbers (dimensionless mass transfer coefficients) with Reynolds numbers, Schmidt numbers, and solids volume fractions. An interesting finding was a reduction in mass transfer rates in fluidized beds as compared to beds of fixed particles. This is caused by hydrodynamic screening effects in fluidized systems.

REFERENCES

1. É. Guazzelli, J. Hinch, Fluctuations and instability in sedimentation, *Annu. Rev. Fluid Mech.* 43, 97 (2011).
2. J.J. Derksen, Simulations of solid-liquid mass transfer in fixed and fluidized beds, *Chem. Eng. J.* 255, 233 (2014).
3. J.J. Derksen, Simulations of scalar dispersion in fluidized solid-liquid suspensions, *AIChE J.* 60, 1880 (2014).

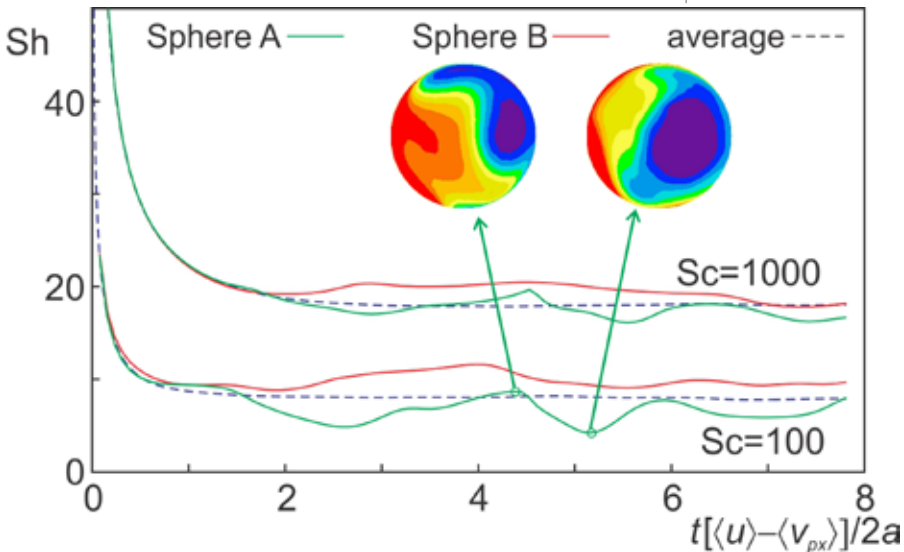

Evolution to dynamic steady state of volume average Sherwood numbers at two values of the Schmidt number. The contour plots are instantaneous impressions of how transfer rates are distributed over the surface of a randomly selected sphere.

BOUNCING ON THIN AIR

J de Ruiter, R Lagraauw, D van den Ende and F Mugele, UT

When millimetre sized drops are sprayed on a flat horizontal substrate they deform substantially under the influence of the ambient air that needs to be squeezed out from below the drop. Depending on impact conditions they get deposited on the surface, or disintegrate in a splash before the liquid actually touches the solid. They even can bounce multiple times on the substrate irrespective of its wettability, provided that a micrometre-thick air layer is sustained below the droplet. We have investigated this bouncing behaviour [1], by analysing the centre of mass motion and its shape oscillations during a bounce series using high speed side view recordings of the droplet. From the centre of mass motion the droplet-substrate interaction force $F = ma_{CM} + mg$ is determined. This force acts always upwards, even just before lift-off of the droplet. This is rather surprising if you note that at these impact speeds the air speed under the droplet is much smaller than the speed of sound. Hence, the flow in the air film is incompressible and the reaction force on the droplet is purely dissipative. In a simple lubrication picture air is sucked in during the retraction phase of the bounce, which suggests a downwards force on the droplet. At lift-off shape oscillations are excited which pertain during the flight phase in between the bounces, indicating that hardly any energy is dissipated during the in-flight oscillations. Hence, most of the dissipation, leading to non-perfect restitution, occurs during the bouncing process itself, despite the continuous presence of a lubricating air film below the droplet.

Reflection interference microscopy was used not only to confirm the existence of the non-vanishing air layer but also to study the role of this air film [2]. We quantify its thickness (typically a few micrometre) with 30nm resolution [3]. Our measurements reveal a strong asymmetry in the air film shape between the approach and retraction phase of the bounce.

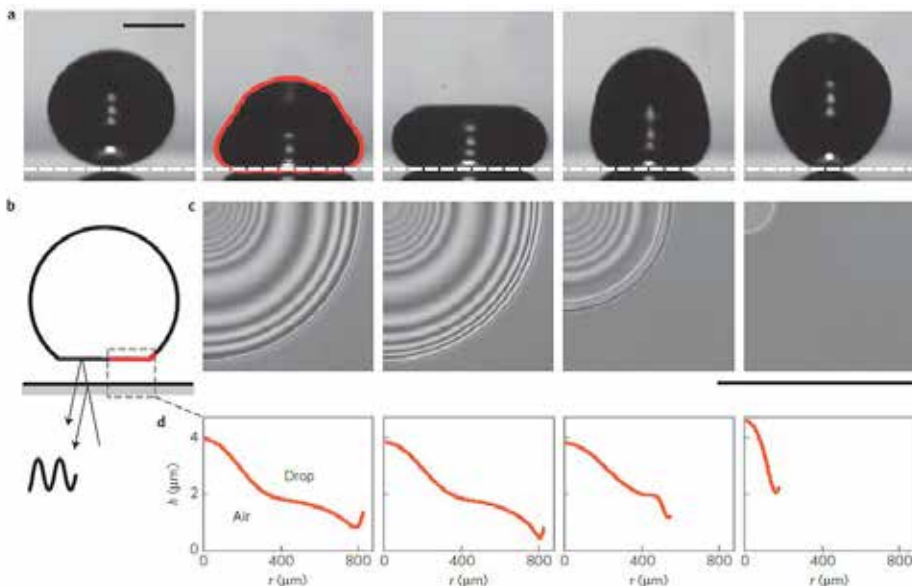

Water drop bouncing on a hydrophilic glass substrate. (a) Side-view images of a water drop impacting at $v = 0.22 \text{ m/s}$. Using reflection interference microscopy (b) we obtain interference patterns (c) from which the radial profiles of the air film thickness (d) are calculated. Scale bars: 1 mm.

The rim of the film moves outward and downward in the approach phase, but inward rather than upward in the retraction phase. This asymmetry turns out to be crucial for an effective momentum reversal of the droplet. Taking this effect into account, lubrication theory shows that indeed the dissipative force is repulsive throughout each bounce, even near lift-off, which leads to a high restitution coefficient and only a limited transfer of energy to the internal oscillation modes. The corresponding dissipation in the air film is strongly concentrated near the rim of the air film. Because this region could be observed only partially, we can only roughly estimate the dissipation in the air film. It contributes between fifty to eighty percent of the total energy loss during the bouncing series, in line with the above mentioned low dissipation during the flight phase.

REFERENCES

1. de Ruiter, J., Lagraauw, R., van den Ende, D., Mugele, F.; Nat. Phys. 11 (2015) 48-53.
2. de Ruiter, J., Oh, J. M., van den Ende, D., Mugele, F.; Phys. Rev. Lett. 108 (2012) 074505.
3. de Ruiter, J., Mugele, F., van den Ende, D.; Phys. Fluids 27 (2015) 012104.

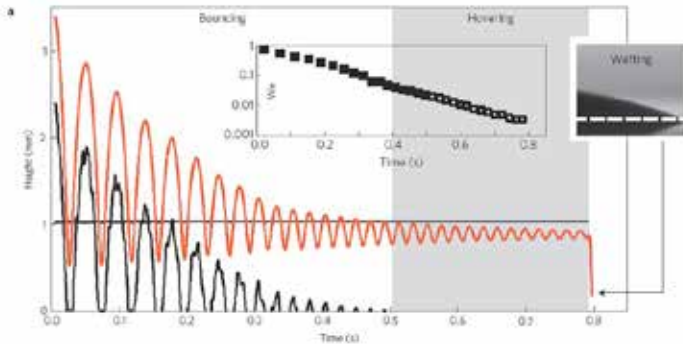

(a) Full bouncing series showing the center of mass height (red) and the air film height (black). The grey shaded area indicates the final hovering phase. (b) Details of the first bounce, center of mass height, air film height and interaction force (blue) based on side-view images. (c) Air film height (black) as obtained from the interference micrographs and the calculated force (blue).

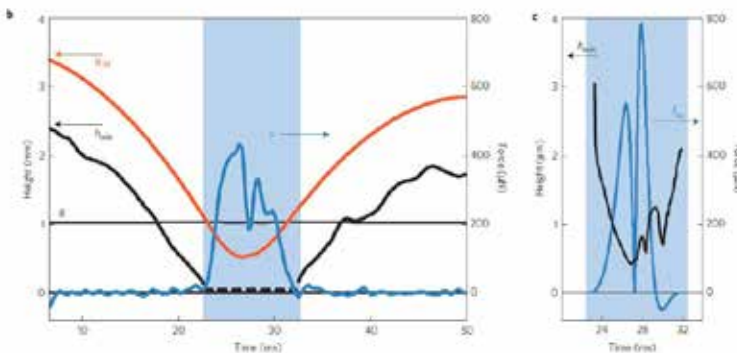

MOLECULAR MODELING OF SUGAR ALCOHOLS AS SEASONAL HEAT STORAGE MATERIALS

H. Zhang, S.V. Nedeia, C.C.M. Rindt, D.M.J. Smeulders

Sugar alcohols (SA) and their eutectic mixtures are promising seasonal heat storage media. These materials are environmentally friendly, low cost, and high in storage capacity. In this way excess heat from summer can be stored and used for winter heating in domestic applications. Recent discoveries show that the eutectic mixtures across species of SA can have even better thermal performances in terms of super cooling effect and latent heat storage capacity. Furthermore, by using encapsulation techniques and carbon foam structures the thermal conductivity can be dramatically improved. However, the nucleation and crystal growth is usually sluggish in such systems, introducing difficulties in large-scale commercial applications. These phase change kinetics as well as the interaction between the eutectic mixtures and the carbon foam structures remain mostly unknown to us and a best way to look into the details is through molecular modeling and simulations.

We have successfully modeled the three most promising SA candidates (xylitol, erythritol, and D-mannitol) and validated their thermodynamic properties using experimental data. A “wall cleaving” numerical method which manipulates the system’s configurational space by introducing external potentials was developed to calculate the free energy of the solid-melt interface. The large anisotropy found in these free energies may account for the dramatic dendritic growth behaviors observed in the experiments. The vibrational density of state throughout the melting process was studied to unveil the dynamic detail when solid-liquid phase change occurs. SA-Carbon systems were modeled using proven force fields. Open-ended single-wall carbon nanotubes are found to be filled up with sugar alcohols molecules under experimental conditions.

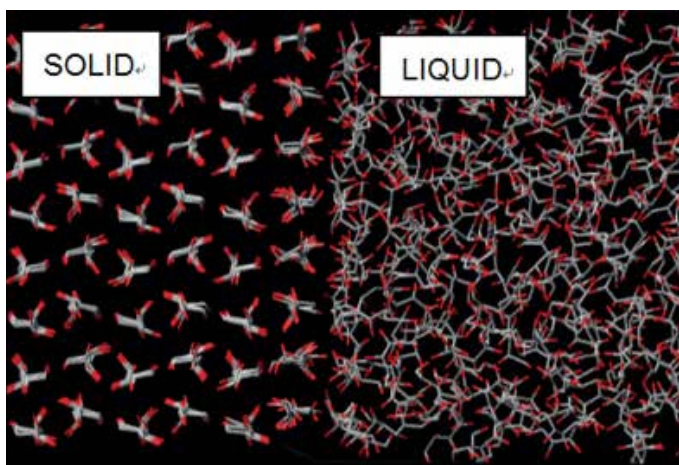
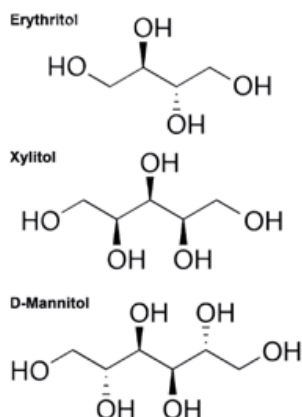

(Left) The three most promising SAs as seasonal heat storage material and (Right) a simulation of xylitol solid liquid interface. Only bonds between C and O atoms are shown here.

REFERENCES

1. Zhang, H., Iype, E., Gaastra - Nedea, S.V. & Rindt, C.C.M. (2014). Molecular dynamics study on thermal dehydration process of epsomite ($\text{MgSO}_4 \cdot 7\text{H}_2\text{O}$). *Molecular Simulation*, 40(14), 1157-1166.
2. Zhang, H., Wissen, R.M.J. van, Gaastra - Nedea, S.V. & Rindt, C.C.M. (2014). Characterization of sugar alcohols as seasonal heat storage media - experimental and theoretical investigations. Conference Paper : Proceedings of the Advances in Thermal Energy Storage, EURO THERM 99, 28-30 May 2014, Lleida, Spain, (pp. EURO THERM99-01-020). Lleida, Spain.
3. Zhang, H., Gaastra - Nedea, S.V., Rindt, C.C.M., Zondag, H.A. & Smeulders, D.M.J. (2014). Prediction of anisotropic crystal-melt interfacial free energy of sugar alcohols through molecular simulations. Conference Paper : Proceedings of the 15th International Heat Transfer Conference (IHTC-15), August 10-15, 2014, Kyoto, Japan, (pp. IHTC15-8636). Begell House.

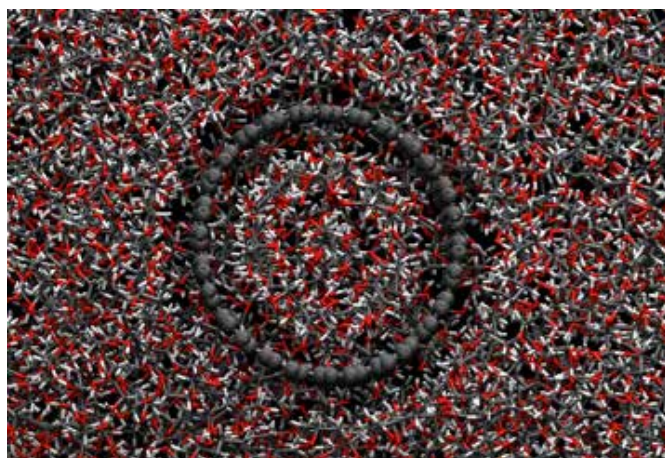

(Above) A snapshot of carbon nanotube (14,14) filled up with xylitol molecules. (Right) Histogram of averaged molecular density in the radial direction of the nanotube from the center. Two layers of xylitol molecules are present in the tube.

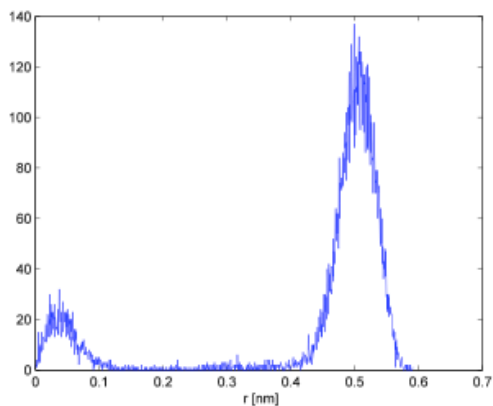

HIGHER FLAME SPEED WITH FRACTAL-GRID-GENERATED TURBULENCE

AA Verbeek, BJ Geurts, TH van der Meer

It remains a challenge in gas turbine development to obtain low-NO_x emissions as government regulations become more and more stringent. In this study low-swirl burners are adapted such that they become suitable for gas turbine application [1]. These burners are known for their extremely low-NO_x levels and are already applied in atmospheric applications. The NO_x reduction of more than 50% can then be achieved in gas turbine power generation which is responsible for a major part of the global energy conversion.

The rate of combustion in premixed natural gas flames is to a large extent controlled by the level of turbulence. To elevate the turbulence level in low-swirl burners so-called fractal grids are applied. These grids are obtained by truncating a self-similar fractal pattern at some level of refinement [2]. A parametric study of fractal-grid-generated turbulence containing 24 different grids with variation in grid patterns, solidity and range of embedded scales was conducted. First, a rod-stabilized, V-shaped flame is used as such stabilization mechanism allows for considerable more variation in upstream fractal grid geometry. It is shown that fractal grids provide much more intense turbulence compared to classical grids. By increasing the range of embedded scales the turbulence is intensified. The turbulence intensity can be more than quadrupled while for the turbulent flame speed more than doubling is observed.

When the standard blockage grid in a low-swirl burner is replaced by fractal grids (see Figure 1) a similar increase in turbulence and combustion rate is observed as for a V-shaped flame. Figure 2 clearly shows both these effects. The turbulence is intensified, which is expressed by more than doubling of the r.m.s. of the velocity fluctuations, while only marginal changes in pressure drop are observed. The OH-LIF experiments show an increase in flame surface density and widening of the flame brush as well as much finer wrinkling of the flame front for the cases involving a multi-scale blocking grid.



Exploded view and actual photo of a low-swirl burner with a fractal grid installed.

The fact that the range of embedded scales mainly controls the turbulence intensity and the blockage ratio the low-swirl stabilization, engineering fractal grids for low-swirl combustion can be done with relative ease. In addition to the effect on the turbulent flame speed, it has also been verified that the low NOx emission levels, a key feature of low-swirl burners, are not affected when using fractal grids.

REFERENCES

1. Cheng, R.K. et al., Proc. Combust. Inst, 28:1 1305-1313 (2000).
2. Hurst, D., Vassilicos, J.C., Phys. Fluids, 19 035103 (2007).

Flame speed as function of the turbulence level.

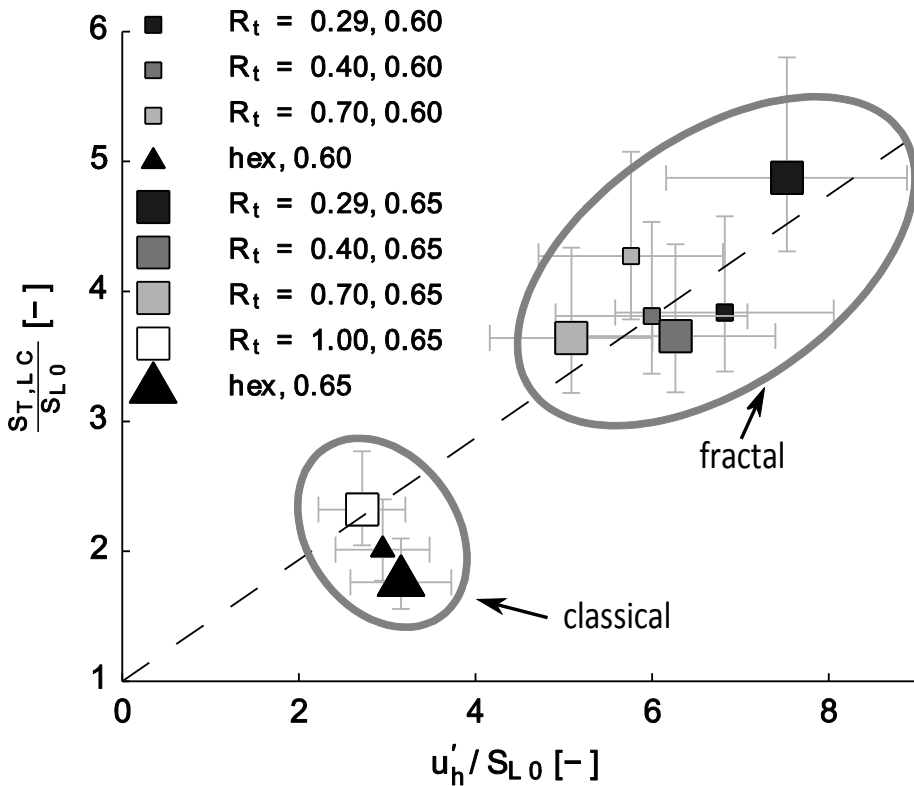

RESEARCH

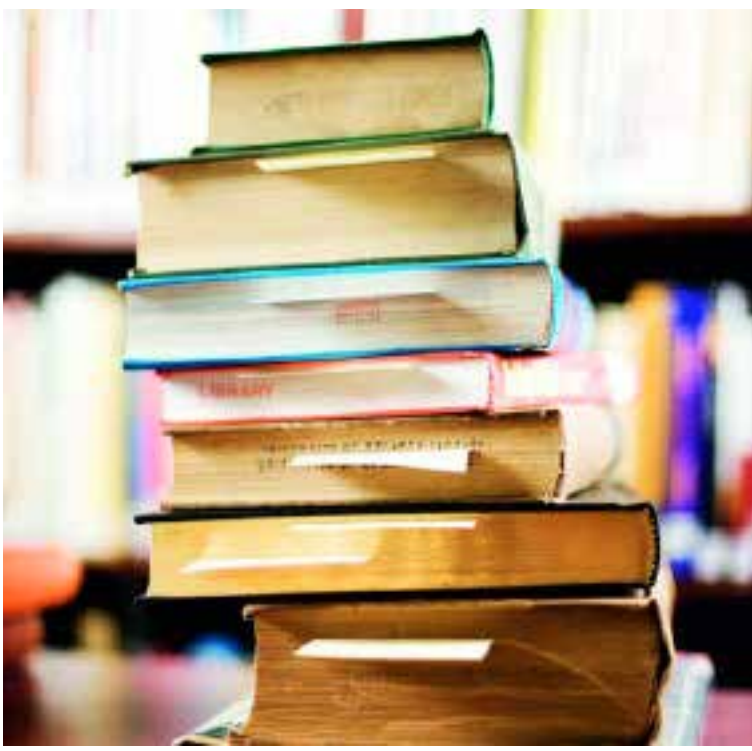

RESEARCH

INTRODUCTION

The research programme of the JMBC has been ordered in research themes and focal points. The reason for this ordering is to present a combination of projects which have coherence, either in terms of physical models or in terms of mathematical methods.

The main themes are:

1. Complex dynamics of fluids
2. Complex structures of fluids
3. Mathematical and computational methods for fluid flow analysis

DESCRIPTION OF THE RESEARCH THEMES

1. COMPLEX DYNAMICS OF FLUIDS

Fluid flows in the environment or in industrial applications are almost always characterised by some form of complexity. Frequently it is this complexity that makes the flow an interesting topic of research. Below we will sketch several examples of such flows and flow phenomena which form research topics carried out in the various groups of the J.M. Burgerscentrum.

The first form of complex dynamics which comes to mind is turbulence in contrast to a laminar flow. Here complexity appears in the form of strong non-linearity. Due to its chaotic behaviour turbulence can be considered as the archetype of a complex flow, and - being far from solved - turbulence will remain a strong focal point of research in the coming period. Turbulence research traditionally addresses the following questions:

- ♦ what are the physical processes and interactions governing turbulence,
- ♦ how can they be quantified and described mathematically,
- ♦ how to predict turbulence and turbulent flow for particular configurations, and
- ♦ how to control and manipulate turbulence?

Future research in this field in particular will focus on laminar-to-turbulent and reverse transition, effects of thermal buoyancy, unsteadiness, compressibility and rotation, and on the interaction with chemical reactions. The role of turbulence in energy conversion processes and equipment are regarded as an intriguing field of applications.

Complexity may also appear in the form of a combined flow of various phases. When these phases are immiscible, phenomena such as free surface flows occur. These may appear in the form of various wave phenomena, for instance on an unobstructed water surface, but also in a confined geometry of a pipe.

Another type of such flow of immiscible phases is when one of the phases is distributed in the form of small particles, bubbles or droplets in the other continuous phase. Various combinations of phases may be selected and each has its own particular problems. This class of flows, generally denoted as dispersed multi-phase flow, at the moment forms a strong focal point of research within the JMBC. The combination of phases that are miscible leads to other interesting problems such as mixing, and - depending on the fluids that take part in the mixing - chemical reactions or combustion.

Finally, complexity of the flow can also appear through its boundary conditions. For instance the flow geometry can strongly influence the flow characteristics by means of straining, shearing and distortion. An example is the wake behind a body in a shearing or straining flow.

Furthermore, the exact formulation of boundary conditions can have a consequence for the type of flow characteristics that appear.

An example is the free convection above a flat surface with a variable the conductivity. Geometry constraints on the flow are also dominant also when one considers a flow in 2D versus 3D. Here one should take as an example the quite different characteristics of 2D turbulence versus 3D-turbulence.

An increasingly important JMBC research activity within Theme 1 is aero-acoustics, aimed at the identification and quantification of acoustic sound sources in internal and external flows. Such sources can be related to unsteady vortex shedding, turbulence, combustion and flow-structure interaction. In general there is a strongly non-linear mutual interaction between sound source and acoustic field. The applications and technical implications show a great diversity. The JMBC is actively involved in vortex sounds in ducts, musical instruments (like the flute and the organ pipe), human speech, acoustics in burner stabilized flames, sound generation by turbulent flames, with much attention to analytical and numerical modelling of these flows.

The flow cases mentioned above, which are by no means an exhaustive list of complex fluid flow phenomena, form research topics in the various groups in the J.M. Burgers Centre.

The tools to carry out this research are primarily numerical and experimental. The numerical techniques used to compute flow phenomena are direct and large eddy numerical simulation, turbulence modelling and computational fluid dynamics. The experimental techniques used nowadays are mostly based on various forms of laser diagnostics (e.g. like PIV and PTV for flow measurements and CARS, LIF and Cavity Ring-Down Spectroscopy for temperatures and concentrations). Experiments, simulations and analytical theories in the field of fluid flow analysis complement each other - perhaps more than in other branches of physics. Future research will inevitably make use and take advantage of combined techniques and their complementing roles. Both the research topics themselves and the research techniques to carry out these investigations, form the basis of a strong collaboration within the J.M. Burgerscentrum.

2. COMPLEX STRUCTURES OF FLUIDS

Research in this Theme deals with complex structures of flow, formed in the presence of particles, drops, or bubbles, i.e., two- or even multi-phase flow. Two-phase flow is of paramount importance in contemporary science and technology.

One can readily cite a multitude of examples: the production and transport of oil (where bubbles are purposely injected to help lift thick heavy oil to the surface, or arise due to the release of dissolved gases), energy generation (where boiling is the key process in producing the steam to drive turbines), the chemical industry (where gas-liquid reactors rely on bubbles to increase the contact area between the phases), the oceans (where breaking-wave generated bubbles are important sinks for atmospheric CO₂), sedimentation (where sinking sand particles determine the structure of our coasts), food-industry, and many others.

The challenge in single-phase flow is to understand the complicated dynamics which is generated by the Navier-Stokes equation. In two-phase flow, even the underlying dynamical equations are often not known. E.g., it is not understood why bubbles repel each other when they are close to each other.

But even when the microscopic interactions are known, it is often not clear how the macroscopic structure evolves from this microscopic interaction and the response to external forces.

In many cases instabilities are involved in the macroscopic structure formation process. Very complex self-organising patterns can evolve out of these instabilities. An important example is cluster formation in sedimentating particles and coherent structures in bubble columns and fluidised beds.

Related topics are flow-controlled nucleation and droplet growth processes in high-pressure natural gas, which have important technical applications in the natural gas industry. Different JMBC groups are involved in the design of new types of condensate separators and in the numerical description of swirling supersonic two-phase flows, while a dedicated facility has been developed in order to investigate these condensation processes in a well-defined way experimentally.

How to theoretically describe such a complex system? Two types of approaches have been described in literature: In the first type of approach, the particles/bubbles/drops are treated essentially as points, while no attempt is made to simulate their detailed response to the liquid dynamics.

The advantage of this approach is that many particles/bubbles/drops can be treated, but the price to be paid is a lot of ad-hoc modelling. Fluid dynamical simulations in which the particles/bubbles/drops are modelled through averaged equations also belong to this first type of approach. In the second type of approach the detailed interactions of the particles/bubbles/drops with the flow is simulated, paying the price that - at present - the surrounding flow can not really be turbulent

and that only “a few” objects can be treated, in particular, when the interfaces are allowed to deform, i.e., for free boundary problems (drops and bubbles).

One of the main objectives for the research in two-phase flow must be to bridge the gap between these two types of approaches and to carry out a detailed investigation of the interaction between one or a few particles/bubbles/ drops and a nontrivial flow field. Another objective must be to better understand the macroscopic structure formation process out of the microscopic interactions, and thus the instabilities in two-phase flow. It is evident that these objectives can only be achieved through a joint experimental, theoretical, and numerical approach.

On the experimental side, the challenge has always been to monitor and document as much information on the dynamics of the flow field as possible. Through the huge advances in both digital imaging techniques and information technology (see Research Theme 3), the field is now flourishing, and the research on two-phase flow will strongly benefit from this. The same is to be expected from the advances with numerical techniques (see Research Theme 4), as brute force numerics will not be sufficient to address the problem of structure formation in two-phase flow. New algorithms and techniques are required and moving toward parallel computing will be essential.

3. MATHEMATICAL AND COMPUTATIONAL METHODS FOR FLUID FLOW ANALYSIS

Advanced mathematical and computational techniques have become indispensable instruments for the description and understanding of complicated flow phenomena. This approach to fluid mechanics has evolved into a full-fledged counterpart to the experimental approach and provides new insight in complex flow physics, in for instance turbulence, combustion, multi-phase and rheological flows.

The use of computational flow models is supported with analytical techniques, which provide deeper insight in canonical flow problems, and strongly interacts with advanced experimental techniques, which are capable of measuring and visualizing complex three-dimensional unsteady flow fields. These techniques require advanced post-processing of the flow field data to understand the flow dynamics and have developed into a research subject in itself. Here tools from non-linear dynamical systems theory can be useful, as well as the decomposition of flow data through POD and wavelet analysis.

The rapid increase in computational power has significantly stimulated the use of computational techniques in flow analysis, but the development of better algorithms has been the most important source for improved numerical techniques for flow analysis.

Many flows are, however, simply too complex for computational techniques and flow modelling remains an essential issue. Compromises have to be found between the inaccuracies in flow modelling and computational constraints. In areas such as turbulent flow simulation much progress has been made through refined modelling via Large-Eddy Simulation (LES) and Direct Numerical Simulation (DNS). There is also an interest for stochastic methods, such as the use of the Langevin equation for the velocity. In the other areas the same trends have become feasible, e.g. PDF modelling in combustion and Brownian Dynamics in rheology.

It can be foreseen that the improvements in numerical algorithms and the growing computational power will open up new applications of flow analysis in other disciplines, such as chemistry, biomedicine and structural mechanics, and will continue to grow in importance. This will be stimulated by the development of new numerical techniques which can efficiently capture flow structures with large differences in length and time scales, the continuous increase in computing power, and by exploiting computational fluid dynamics in multi-physics applications.

REVIEW OF PROGRESS IN RESEARCH PROJECTS

As agreed by the project leaders of the JMBC only doctoral thesis, (contributions to) books, and publications in scientific journals and in proceedings of conferences with a referee system, are given in the output for each project. Only 2013 publications are taken up in the project descriptions.

An important output for various JMBC-groups is in the form of special reports for industries, technological institutes, etc. Those reports are not mentioned in the output of the projects. For more information, please contact the relevant project leaders.

FLUID MECHANICS



Prof.dr.ir. J Westerweel



Prof.dr.DJEM Roekaerts



Prof.dr.ir. RAWM Henkes



Prof.dr. JCR Hunt



Prof.dr.ir. G Ooms



Prof.dr.ir. B Eckhardt

Within the Department Process & Energy the chair of energy technology of prof. BJ Boersma, the chair of fluid mechanics of prof. J. Westerweel, and the chair of turbulent reacting flows of prof.dr. DJEM Roekaerts, are complemented by: dr.ir. WP Breugem, dr. P Colonna, dr. R Delfos, dr.ir. GE Elsinga, dr.ir. W de Jong, dr. R Pecnic, dr.ir. C Poelma, dr.ir. MJBPM Pourquie, dr. D Tam, dr.ir. M Tummers, and part-time chairs: prof.dr. B Eckhardt, prof.dr.ir. RAWM Henkes, prof.dr. JCR Hunt FRS, and prof.dr.ir. G Ooms.

The common themes of the research in the department group are: (i) turbulence and complex flows, such as multiphase flows, microfluidics, biological flows, and fluid mechanics of sports, (ii) turbulence in supercritical fluids, rotating machinery and gas turbines, energy conversion processes, and aeroacoustics, and (iii) turbulent mixing in non-reacting and reacting flows, turbulence-chemistry-radiation interaction in flames, and turbulent heat transfer.

The research is aimed at fundamental aspects of flows, but always with a clear connection to a practical application or process in industry. Experimental and computational studies are made of systems at different scales, from lab-scale to industrial scale. Detailed investigations are made using laser diagnostic techniques (such as particle image velocimetry, laser-induced fluorescence, and other spectroscopic methods) and using advanced computational models, such as large-eddy simulation and direct numerical simulation. The program responds to a substantial drive from society and industry, for example for more environmentally friendly combustion processes avoiding the formation of NO_x and particulates (soot) in industrial combustion systems (furnaces, gas turbines, engines), and for the development of energy efficient processes (e.g., through drag reduction). The activities in microfluidic flows aim at the investigation of small-scale cardiovascular flows, flow geometries with complex boundary conditions (such as microflagella), and micro-scale multiphase flows.



Prof.dr.ir. BJ Boersma

MODELLING AND EXPERIMENTS FOR BY-PASS PIGGING WITH SPEED CONTROL

PROJECT AIM

A Pipeline Inspection Gauge (pig) is a cylindrical device that fits onshore or offshore pipelines for the transport of gas, oil, water in the oil and gas industry. The pig is launched at the inlet and received at the outlet. It is used for various purposes, such as water removal to prevent corrosion, removal of wax deposition along the pipe walls, removal of other solids, and inspection of the pipe wall condition. The use of a pig with an opening in the centre (a so-called by-pass pig) will allow some of the fast moving gas to flow through the pig during the pigging operation. The aim of this PhD project is to develop an optimum way to control the speed of the by-pass pig.

PROGRESS

A report has been written with an overview of the pig physics, field applications and available literature. A 1D compressible stratified two-fluid model is being developed to predict the speed controlled bypass pig dynamics in a pipeline. The fluid flow around a by-pass pig has been simulated using 2D single phase CFD (Fluent) to obtain the pressure loss coefficient of various by-pass pig configurations. Results from CFD can be incorporated in the 1D model. The CFD study is continued to account for more complex by-pass pigs. In addition, the frictional force during the pigging operation will be investigated using finite element modelling. Experiments are planned to visualize the flow regime around the by-pass pig in an air-water flow loop. This loop consists of a 136 meter long pipe with a sharp bend. The pipe diameter is 52 mm.

DISSERTATIONS

-

SCIENTIFIC PUBLICATIONS

-

PROJECTLEADERS

RAWM Henkes, WP Breugem

RESEARCHTHEME

Complex dynamics of fluids

PARTICIPANTS

MHW Hendrix, RAWM Henkes,

WP Breugem

COOPERATIONS

-

FUNDED

Shell Global Solutions International

BV

University -

FOM -

STW -

NWO Other -

Industry 100 %

TNO -

GTI -

EU -

Scholarships -

START OF THE PROJECT

2013

INFORMATION

M Hendrix

06 50987039,

M.H.W.Hendrix@tudelft.nl

DISPERSION BY TURBULENCE IN THE URBAN ENVIRONMENT (DISTURBE)

PROJECT LEADERS

J Westerweel, GE Elsinga,
M Pourquie, HJJ Jonker, JCR Hunt

RESEARCH THEME

Complex dynamics of fluids

PARTICIPANTS

J Eisma, J Tomas, M Goudar
Vishwanathappa

COOPERATIONS

-

FUNDED

| | |
|----------------------------|------|
| KEMA, TNO, FlowMotion, RWS | |
| University | - |
| FOM | - |
| STW | 85 % |
| NWO Other | - |
| Industry | 10 % |
| TNO | 5 % |
| GTI | - |
| EU | - |
| Scholarships | - |

START OF THE PROJECT

2012

INFORMATION

GE Elsinga
015 278 8179
G.E.Elsinga@tudelft.nl
<http://delftpe.nl/Chairs/FM>

PROJECT AIM

The current research proposal aims at finding the mechanisms that are responsible for the turbulent dispersion of air pollution near major urban roadways. The project focuses on complex geometries at the scale of several buildings and roadways (10-1000m), which are typical of cities. Finally, attention is given to the prediction of peak pollution concentrations.

PROGRESS

A new model has been developed in order to predict the growth rates of internal layers in a turbulent boundary layer, indicating that internal shear layers grow only slowly when evolving in space. Preliminary LIF visualizations on a point source in a TBL indicate a slow spreading of the pollutants emitted from the source, suggesting that interfaces might play a role in pollutant dispersion.

The effect of a fence on flow and pollutant dispersion in neutral and stable boundary layers has been investigated by means of Large-Eddy simulations. Accurate neutral and stably stratified inflow boundary layers were generated in separate simulations using a recycling method. It is found that turbulence (and pollutant dispersion) is affected by the obstacle farther than 100 obstacle heights downstream. Moreover, the decay in turbulence and concentration excess decreases appreciably with increasing stability. On the other hand, the decay in mean velocity deficit appears to be independent of stratification.

Particles were simulated around an ideal flow structure extracted from isotropic turbulent flows as shown in Elsinga et al., 2010. Similar simulations were also performed with extracted structures from fully developed channel flows. It was found that the pair dispersion statistics for around ideal structures were qualitatively very similar to the actual pair dispersion behavior in fully developed turbulent flows as reported in the literature.

DISSERTATIONS

-

SCIENTIFIC PUBLICATIONS

-

LIQUID ACCUMULATION IN NEARLY HORIZONTAL PIPELINES WITH MULTIPHASE FLOW AT LOW GAS PRODUCTION RATES

PROJECT AIM

The project aims at improving the basic understanding of a key aspect of multiphase flow in pipelines as used in the gas and oil industry, which is the liquid accumulation in systems under turndown operational conditions. The experimental lab configuration will consist of a V-shaped piece of pipeline, representing the low spot. The turbulence levels will be measured using Particle-image Velocimetry. The experimental data will be used to improve the one-dimensional models used in the gas and oil industry, as well as in the next generation type of models, based on three-dimensional Reynolds Averaged Navier Stokes (RANS) equations.

PROGRESS

An experimental study was performed in stratified wavy flow of air and water through a horizontal pipe. The velocity fields were measured in both phases simultaneously using PIV, and the interfacial shape was resolved using a profile capturing technique. The main objective of the study was to investigate both the interfacial characteristics and the velocities in both phases in two wave patterns: '3D small amplitude' and '2D large amplitude' waves. The wave patterns were shown to have substantial differences in wave characteristics and time- and phase-averaged liquid velocities. The 2D LA waves had higher and longer waves that substantially changed the liquid velocities in almost the entire liquid layer. The 3D SA wave patterns had smaller and shorter waves whose influence extended only throughout a part of the liquid height. Future modelling should consider the physics of the two phases and the interface combined, since there is always a f interaction between them.

DISSERTATIONS

-

SCIENTIFIC PUBLICATIONS

1. Birvalski, M., Tummers, M.J., Delfos, R., Henkes, R.A.W.M., PIV measurements of waves and turbulence in stratified horizontal two-phase pipe flow. *Int. J. Multiphase Flow* 62, pp. 161-173, 2014.
2. Birvalski, M, Koren, G.B. & Henkes R.A.W.M., Experiments and modelling of liquid accumulation in the low elbow of a gas/liquid pipeline. In D Carrington & S Smith (Eds.), *Proceedings of the 9th North American Conference on Multiphase Technology 2014* (pp. 41-55). Cranfield, UK: BHR Group, 2014.
3. Van der Gronden, W.R., Haandrikman, G, T'Joel, C.G.A., Henkes R.A.W.M., Twophase flow splitting experiments in an impacting tee with two risers. In D Carrington & S Smith (Eds.), *Proceedings of the 9th North American Conference on Multiphase Technology 2014* (pp. 57-69). Cranfield, UK: BHR Group, 2014.
4. Kroes, R.F., Henkes, R.A.W.M., CFD for the motion of elongated gas bubbles in viscous liquid, In D Carrington & S Smith (Eds.), *Proceedings of the 9th North American Conference on Multiphase Technology 2014* (pp. 283-298). Cranfield, UK: BHR Group, 2014.

PROJECT LEADERS

RAWM Henkes, MT Tummers,
R Delfos

RESEARCH THEME

Complex dynamics of fluids

PARTICIPANTS

M Birvalski

COOPERATIONS

Shell

FUNDED

| | |
|--------------|------|
| Shell | |
| University | 25 % |
| FOM | - |
| STW | - |
| NWO Other | - |
| Industry | 75 % |
| TNO | - |
| GTI | - |
| EU | - |
| Scholarships | - |

START OF THE PROJECT

2010

INFORMATION

RAWM Henkes

06 52096201

R.A.W.M.Henkes@tudelft.nl

PERFORMANCE OF FOAMERS FOR DELIQUIFICATION OF GAS WELLS

PROJECT LEADERS

RAWM Henkes, LM Portela

RESEARCH THEME

Complex structures of fluids

PARTICIPANTS

AT van Nimwegen

COOPERATIONS

NAM/Shell

FUNDED

NAM

University 25 %

FOM -

STW -

NWO Other -

Industry 75 %

TNO -

GTI -

EU -

Scholarships -

START OF THE PROJECT

2010

INFORMATION

RAWM Henkes

06 52096201

R.A.W.M.Henkes@tudelft.nl

PROJECT AIM

This project is a combined experimental/modeling study on the performance of foamers for deliquification of gas wells as used in the gas and oil industry. The reduction of the reservoir pressure for maturing fields will cause that gas wells will start to accumulate liquid (water, condensate). The use of proper foamer chemicals will mix the liquid and gas into a foam, which decreases the hydrostatic head in the well and re-establishes the flow. The study includes flow experiments using a 12 m, 5 cm diameter facility.

PROGRESS

Experiments were performed in three flow loops, which are now fully operational: the diameters of the flow loops are 34 mm and 50 mm (12 m in length) and 80 mm (18 mm in length). These results show that the effect of surfactants on air-water pipe flow can be understood in terms of the film at the wall of the pipe. The foam that is created when surfactants are present increases the film thickness and decreases the film density, making it easier for the air to drag the film upwards. As a result, surfactants reduce the pressure gradient at low gas flow rates. Surfactants are more effective for thinner liquid films: i.e. for lower liquid flow rates and smaller diameters. From this work, four more papers were written, which have been submitted or are soon to be submitted. The dissertation is finished in Q1 2015.

DISSERTATIONS

-

SCIENTIFIC PUBLICATIONS

1. A. T. van Nimwegen, L. M. Portela, and R. A.W. M. Henkes. The effect of surfactants on air-water annular and churn flow in vertical pipes. part 1: Morphology of the air-water interface. *International Journal of Multiphase Flow* (2014). doi: 10.1016/j.ijmultiphaseflow.2014.03.008.
2. A. T. van Nimwegen, L. M. Portela, and R. A.W. M. Henkes. The effect of surfactants on air-water annular and churn flow in vertical pipes. part 2: Liquid holdup and pressure gradient dynamics. *International Journal of Multiphase Flow* (2014). doi: 10.1016/j.ijmultiphaseflow.2014.03.007.
3. A. T. van Nimwegen, L. M. Portela, and R. A.W. M. Henkes. The effect of surfactants on the flow patterns in vertical air-water pipe flow. In *Proceedings of the ASME 2014 4th Joint US-European Fluids Engineering Division Summer Meeting, FEDSM2014-21845*, Chicago, (2014).

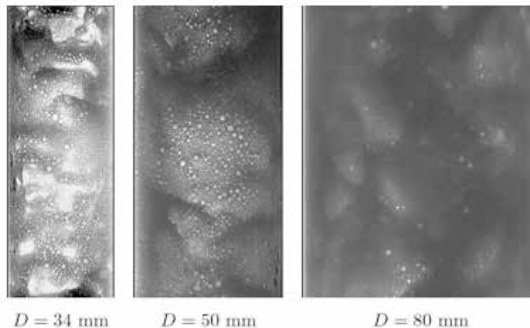

MODELLING THE INFLUENCE OF FLOW ON ASPHALTENE AGGLOMERATION AND DEPOSITION

PROJECT AIM

Asphaltenes are heavy organic deposits that can be formed when the oil transport from subsurface reservoirs undergoes a sharp drop in pressure. Models are used for the prediction of asphaltene deposition and give important input to the design of deposition prevention and remediation methods. Models used so far in the oil and gas industry are highly empirical. The aim of the present project is to better understand the fundamentals of the influence of flow on the agglomeration and deposition process of asphaltenes. This will result into both new detailed flow models, as well as into improved models that can be used in the industry.

PROGRESS

In the first two years of this project, a primary-particle based numerical model for flow-induced transport, agglomeration and break-up of a dispersed phase was developed. In 2014, this model was extended by considering also deposition and re-entrainment. An initial parameter study of the deposition model was conducted and it was found that deposition predominantly occurs close to the region where primary particles are injected in the computational domain (viz. the region where phase separation of asphaltenes occurs). Furthermore, the model was extended to allow studying pipe geometries in addition to the channel geometry considered so far in this project; currently, we are investigating to what extent the geometry of the domain influences the properties of the agglomerates formed, as well as the deposition and re-entrainment rates.

DISSERTATIONS

-

SCIENTIFIC PUBLICATIONS

-

PROJECT LEADERS

RAWM Henkes, LM Portela, A Twerda

RESEARCH THEME

Mathematical and computational methods for fluid flow analysis

PARTICIPANTS

KCJ Schutte

COOPERATIONS

TNO, ENI (ISAPP2)

FUNDED

| | |
|--------------|------|
| ENI | |
| University | 25 % |
| FOM | - |
| STW | - |
| NWO Other | - |
| Industry | 75 % |
| TNO | - |
| GTI | - |
| EU | - |
| Scholarships | - |

START OF THE PROJECT

2011

INFORMATION

RAWM Henkes

06 52096201

R.A.W.M.Henkes@tudelft.nl

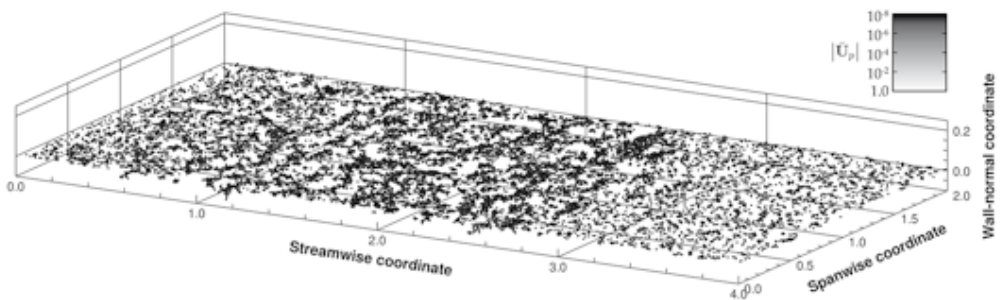

Snapshot of deposit layer formed in turbulent flow

MITIGATION OF FLOW-INDUCED VIBRATIONS IN CORRUGATED PIPES BY MEANS OF LIQUID ADDITION

PROJECT LEADERS

C Poelma, J Westerweel

RESEARCH THEME

Complex dynamics of fluids

PARTICIPANTS

AC van Eckeveld

COOPERATIONS

Shell

FUNDED

NShell

University -

FOM -

STW -

NWO Other -

Industry 100 %

TNO -

GTI -

EU -

Scholarships -

START OF THE PROJECT

2013

INFORMATION

AC van Eckeveld

06 12644266

a.c.vaneckeveld@tudelft.nl

<http://delftpe.nl/node/792>

PROJECT AIM

Development of physical understanding on sound mitigation in corrugated pipes, with a focus on industrial circumstances. Aimed at providing input for design purposes of corrugated risers.

PROGRESS

First experiments carried out. Work on liquid filled cavities subject to a gaseous grazing flow. Goal was an assessment of the effect of liquid filling on the behavior of the shear layer over the cavity and the relation of liquid filling to sound attenuation in corrugated pipes. PIV experiments carried out in both liquid and gas phase.

DISSERTATIONS

-

SCIENTIFIC PUBLICATIONS

-

FULLY RESOLVED SIMULATIONS OF DENSE TURBULENT SEDIMENT TRANSPORT

PROJECT AIM

The aim of this PhD project is two-fold: 1) develop a state-of-the-art computational method for fully resolved simulations of dense particle-laden turbulent flows and 2) study the structure and dynamics of these flows with the developed method.

PROGRESS

We developed a new programming code for interface-resolved simulations of flows laden with finite-sized particles. The physical realism of the lubrication model was improved and a model for tangential collision forces (stick/slip effects) was implemented. This new model was validated against several benchmark experiments. From a computational point of view, the code can now simulate many more particles and larger flow domains. The good performance of the new implementation was confirmed in the workshop "High Performance Computations for Fluid Dynamics: Interface treatment and finite size particles" organized by CALMIP (Calcul en Midi-Pyrénées) that took place in Toulouse in November 2014. Simulations of turbulent channel transport with more than half a million interface-resolved particles are going to be started soon.

DISSERTATIONS

-

SCIENTIFIC PUBLICATIONS

-

PROJECT LEADERS

WP Breugem, BJ Boersma,
J Westerweel

RESEARCH THEME

Complex dynamics of fluids

PARTICIPANTS

PS Costa, WP Breugem,
BJ Boersma, J Westerweel

COOPERATIONS

-

FUNDED

FCT, The Portuguese Foundation for
Science and Technology

University -

FOM -

STW -

NWO Other -

Industry -

TNO -

GTI -

EU -

Scholarships 100 %

START OF THE PROJECT

2013

INFORMATION

PS Costa

015 278 4194

p.simoes.costa@gmail.com

<http://www.pe.tudelft.nl/node/663>

PROJECT LEADERS

J Westerweel

RESEARCH THEME

Complex dynamics of fluids

PARTICIPANTS

A Greidanus, R Delfos

COOPERATIONS

InnoSportNL, DSM, TNO, MARIN

FUNDED

InnoSportNL, DSM, MARIN

University -

FOM -

STW -

NWO Other -

Industry 100 %

TNO -

GTI -

EU -

Scholarships -

START OF THE PROJECT

2010

INFORMATION

A Greidanus

015 278 2904

A.J.Greidanus@tudelft.nl

www.ahd.tudelft.nl

PROJECT AIM

Low drag surfaces are often desired in many industries with applications in open and closed channel flows, such as ship hulls and pipe flows. Drag reduction is a phenomenon that can have substantial energy savings, resulting in ecological and economic benefits. Also for watersports the friction of water is a large contributor to the total drag. Reducing this drag leads to higher velocities. The friction can be reduced by changing the surface properties, due to coatings, which will influence the interaction between water and object. The project aim is to develop, characterize and testing specific coatings which will reduce this friction drag.

PROGRESS

The Taylor-Couette testing facility of the Laboratory for Aero- & Hydrodynamics at the Delft University of Technology proved to be useful to analyze the drag reducing effect of specific surfaces and products. A maximum of 5% drag reduction is observed by the implementation of a riblet surface. A rotation effect is observed for drag reducing surfaces and a correction for the rotation effect is suggested to identify the netto drag reduction. Self-developed coatings will be characterized and tested on their drag reducing effect, in combination with PIV measurements to related the change in drag to the change in flow dynamics..

DISSERTATIONS

-

SCIENTIFIC PUBLICATIONS

-

DEVELOPMENT OF LONG-RANGE MICRO-PIV FOR HIGH REYNOLDS NUMBER TURBULENCE

PROJECT AIM

The long-range microscopic PIV technique has been proposed in the last years to examine microscopic flow phenomena in macroscopic flows such as boundary layers and jets at high Reynolds numbers. The first goal is to implement this technique in our high pressure vessel to measure jet flow. The main aim is then to measure and characterize the small scale in this turbulent flow such as occurring in the interface between turbulent and non-turbulent flow region.

PROGRESS

Long-range microscopic PIV was performed in the fully developed region of an air jet at high Reynolds number. The measurement was performed along the centerline of the jet, where the Kolmogorov length scale (η) is estimated to be 55 μm . A vector spacing of 1.5η allowed the fine scales of turbulence to be confidently resolved. The structures of intense vorticity were found to organize themselves in the shape of elongated vortices (the so called worms), with a characteristic diameter of 10η . Adjacent to the intense vortices, the regions of intense dissipation exhibit a preferential tendency to appear. They were found to assume a sheet-like shape, with a characteristic thickness of approximately 10η . Furthermore, the jpdf of the two invariants of the reduced velocity gradient tensor (VGT) exhibits the characteristic teapot-shape that could be found in other turbulent flows. The asymmetric distribution of the jpdf is an evidence for the amplification of enstrophy on average, and for the predominance of vortex stretching. These results are in agreement with previous numerical and experimental studies at lower Reynolds number, and are collected in a journal article in *Experiments in Fluids*. The final report for the sponsor (EU) of the project was produced and delivered. From hot-wire anemometry measurements in the same flow, the large-scale fluctuations modulate the small-scale signal both in amplitude and in frequency. The present dataset from long-range microscopic PIV was used to study the activity of the small-scale motions in relation to their position either in high- or in low-speed regions of the flow. The spatially resolved velocity vector fields allowed to quantify amplitude modulation directly in physical space. From this estimation directly in physical space, amplitude modulation is only 25% of the value measured from hot-wire anemometry. Furthermore, the size of the structures of intense vorticity does not change importantly in relation to the large-scale velocity fluctuation, meaning that there is no significant spatial frequency modulation. The remaining amplitude modulation in space can be explained as a statistical coupling between the strength of the structures of vorticity and their preferential location inside large-scale high velocity regions. These findings are reported in an article submitted to the *Journal of Fluid Mechanics*.

DISSERTATIONS

-

SCIENTIFIC PUBLICATIONS

1. D. Fiscaletti, G.E. Elsinga, J. Westerweel. "Long-range μPIV to resolve the small scales in a jet at high Reynolds number." In: *Exp. Fluids* 55 (2014), p. 1812.
2. D. Fiscaletti, B. Ganapathisubramani, G.E. Elsinga. "Amplitude and frequency modulation of the small scales in a jet." *J. Fluid Mech.* Submitted (2014).

PROJECT LEADERS

J Westerweel, GE Elsinga

RESEARCH THEME

Complex dynamics of fluids

PARTICIPANTS

D Fiscaletti

COOPERATIONS

Universitaet der Bundeswehr
Muenchen

FUNDED

| | |
|--------------|-------|
| EU | |
| University | - |
| FOM | - |
| STW | - |
| NWO Other | - |
| Industry | - |
| TNO | - |
| GTI | - |
| EU | 100 % |
| Scholarships | - |

START OF THE PROJECT

2011

INFORMATION

D Fiscaletti

D.Fiscaletti@tudelft.nl

www.pe.tudelft.nl/Chairs/FM

PROJECT LEADERS

DSW Tam

RESEARCH THEME

Complex dynamics of fluids

PARTICIPANTS

G Quaranta

COOPERATIONS

Dr. ME Aubin, Kavli Institute Delft

FUNDED

University 100 %

FOM -

STW -

NWO Other -

Industry -

TNO -

GTI -

EU -

Scholarships -

START OF THE PROJECT

2013

INFORMATION

D TAM

015 278 2991

D.S.W.Tam@tudelft.nl

PROJECT AIM

Unraveling, through experimental study, the minimal physical mechanisms necessary to achieve spontaneous beating and synchronization of cilia. This is obtained by dynamically interacting with flagellated micro-organisms (algae *C. Reinhardtii*) in real time, by generating an external mechanical forcing in the relevant force range and at the relevant length and time scales. These experiments will answer the long standing question of whether cilia can synchronize via hydrodynamic interactions only.

PROGRESS

The project investigation has started in May 2013. The experimental setup is now fully working and data has been taken to evidence synchronization of eukaryotic flagella with external flows. Significant results have been collected confirming the hypothesis that synchronization of the organism with an external oscillator can be induced by hydrodynamics interaction only.

DISSERTATIONS

-

SCIENTIFIC PUBLICATIONS

-

ULTRASOUND PARTICLE IMAGE VELOCIMETRY

PROJECT AIM

The primary aim of the project is to investigate and advance the application of ultrasound particle image velocimetry (ultrasound PIV) for flow characterization in a non-intrusive manner. The secondary aim of the project is to non-intrusively measure opaque multi-phase, multi-component flows for diagnostic purposes such as to study non-Newtonian rheology.

PROGRESS

We are currently investigating and optimizing the application of ultrasound PIV for flow measurements in two different flow setups. The first project involves measurement of laminar and turbulent flows in a pipe and investigate the instantaneous flow structures that could be resolved using ultrasound PIV. So far, the new ultrasound imaging module has been calibrated using the aforementioned pipe flow setup. This setup is suitable for flow measurements of both transparent and opaque fluids. The second project involves the study of non-Newtonian fluid rheology using ultrasound PIV. The rheology study is currently being done in cooperation with Shell. The fluid under study is the multi-phase, multi-component drilling mud that is used in the drilling operation of the oil pipes. We are currently investigating the feasibility and capability of ultrasound PIV as a non-intrusive diagnostic tool for an online - inline rheometry.

DISSERTATIONS

-

SCIENTIFIC PUBLICATIONS

-

PROJECTLEADERS

C Poelma, J Westerweel

RESEARCHTHEME

Complex dynamics of fluids

PARTICIPANTS

A Gurung

COOPERATIONS

Shell

FUNDED

| | |
|--------------|-------|
| University | - |
| FOM | - |
| STW | - |
| NWO Other | - |
| Industry | 100 % |
| TNO | - |
| GTI | - |
| EU | - |
| Scholarships | - |

START OF THE PROJECT

2014

INFORMATION

A Gurung

0618797082

A.Gurung@tudelft.nl

<http://delftpe.nl/node/857>

PROJECT LEADERS

WP Breugem, TJC van Terwisga,
J Westerweel

RESEARCH THEME

Complex dynamics of fluids

PARTICIPANTS

FT Charruault, WP Breugem,
TJC van Terwisga, J Westerweel

COOPERATIONS

AkzoNobel Marine & Protective
Coatings

FUNDED

| | |
|--------------------|-------|
| STW (TKI Maritiem) | |
| University | - |
| FOM | - |
| STW | 100 % |
| NWO Other | - |
| Industry | - |
| TNO | - |
| GTI | - |
| EU | - |
| Scholarships | - |

START OF THE PROJECT

2014

INFORMATION

F Charruault
015 278 4766
f.t.charruault@tudelft.nl

PROJECT AIM

The frictional drag of a ship can contribute to up to 70% of the total ship drag. This contribution can be strongly reduced by generating continuous air layers or so-called air cavities along the bottom surface of the ship. However, the efficiency of an air cavity depends heavily on the power needed to compensate for air leakage to the surroundings. In a previous PhD project two different mechanisms were identified to explain air cavity leakage: re-entrant jet entrainment and wave pinch-off entrainment. Our hypothesis is that a hydrophobic hull coating will strongly reduce the latter. We will perform both experiments and numerical simulations to test this hypothesis.

PROGRESS

The PhD project has started in Oct 2014. The PhD student started with a literature study. Currently, a begin is made with setting up experiments to measure the detailed topology of an air/water interface.

DISSERTATIONS

-

SCIENTIFIC PUBLICATIONS

-

DIRECT NUMERICAL SIMULATION OF COMPRESSIBLE TURBULENT FLOWS CLOSE TO THEIR VAPOR-LIQUID CRITICAL POINT

PROJECT AIM

Here we propose to perform the first compressible DNS of wall bounded turbulent flows with fluids close to their vapor-liquid critical point. The configuration is a classical channel flow with periodic boundary condition in the span-wise and stream-wise directions and no slip boundary conditions at both walls. A fully developed turbulent flow is heated on the lower – and cooled at the upper wall. The resulting turbulent flow field has only one inhomogeneous direction (wall-normal coordinate), which will enable a detailed study of the complex compressible flow physics involved. The Mach number will be chosen to be relevant for the technical applications described in section 6.1, between $Ma=0.1$ and 1.2 . The Reynolds number will be defined depending on the accessible computing facilities (The National Computer Facilities – NCF, or PRACE/DEISA – EU facilities). Due to the acoustic CFL restriction on time step size of compressible flow simulations, high-performance computing facilities and extremely efficient numerics are essential.

PROGRESS

Theoretical study regarding the equations of state valid close to the vapour liquid critical point has been done and a compressible turbulent DNS channel code has been developed a simulations have been performed for an ideal gas a low Mach Number (0.2) and also at a higher Mach Number (1.5). Currently, validation is being done with data published in previous literature.

DISSERTATIONS

-

SCIENTIFIC PUBLICATIONS

-

PROJECTLEADERS

BJ Boersma, R Pecnik

RESEARCHTHEME

Mathematical and computational methods for fluid flow analysis

PARTICIPANTS

U Sengupta, R Pecnik, BJ Boersma

COOPERATIONS

TU Delft

FUNDED

TU Delft

University -

FOM 100 %

STW -

NWO Other -

Industry -

TNO -

GTI -

EU -

Scholarships -

START OF THE PROJECT

2013

INFORMATION

U Sengupta

06 44070528

u.sengupta@tudelft.nl

THE INFLUENCE OF THE PROPERTIES OF ANTIFOULING COATINGS ON THE SKIN FRICTION AND TURBULENT BOUNDARY LAYER ALONG A SHIP

PROJECT LEADERS

WP Breugem, J Westerweel

RESEARCH THEME

Complex dynamics of fluids

PARTICIPANTS

HOG Benschop, WP Breugem,
J Westerweel

COOPERATIONS

We are part of a consortium consisting of 19 university groups, technology institutes and companies spread over Europe.

FUNDED

EU/FP7/OCEAN.2013.3 program

| | |
|--------------|-------|
| University | - |
| FOM | - |
| STW | - |
| NWO Other | - |
| Industry | - |
| TNO | - |
| GTI | - |
| EU | 100 % |
| Scholarships | - |

START OF THE PROJECT

2014

INFORMATION

H Benschop
015 278 6597
h.o.g.benschop@tudelft.nl

PROJECT AIM

This project is part of the European FP7 SEAFRONT program with the aim to develop environmentally benign antifouling coatings for ships. The specific goal of this PhD project is to develop fundamental understanding of the influence of the antifouling coating properties on the skin friction and the turbulent boundary layer along a ship. To this purpose Direct Numerical Simulations will be used to study the influence of the surface texture of a coating on the structure and dynamics of turbulence. In a later stage detailed experiments will be performed in our water tunnel on the turbulent boundary layer over various antifouling coatings developed within this program.

PROGRESS

Nowadays it is quite well-known that shark skin riblets can reduce drag in turbulent flows. Studies in the past have shown that blade riblets are optimal in this respect. These thin fences, aligned parallel with the flow, can reduce turbulent drag up to 10 %. Direct Numerical Simulations (DNS) have been performed to study the flow over textured coatings, including the blade riblets. DNS are valuable to study turbulent flows and their statistics, like drag. Our focus has been on textured coatings that exhibit drag reducing behavior. Blade riblets have been investigated with DNS to validate our numerical method. An extensive sensitivity study has been performed to find out what parameters influence the computed drag reduction. A start has been made with the investigation of other possibly drag reducing textured surfaces.

DISSERTATIONS

-

SCIENTIFIC PUBLICATIONS

-

PROJECT AIM

In swimming and rowing (sports) improved athlete performance is obtained by real-time feedback to coaches and athletes. The objective is to maximize propulsion effectiveness by providing feedback about the hydrodynamics. To provide feedback flow characteristics enhancing propulsion are to be identified, quantified, and optimized. A method enabling real-time measurement of these characteristics is to be developed. Also a strong desire exists to measure the hydrodynamic losses, i.e. what amount of energy is dissipated in the water thus not increasing the kinetic energy of the boat/body.

PROGRESS

A literature study provided insight in the phenomena responsible for propulsion, e.g. lift, drag, vortex shedding. Further, requirements for an experimental setup able to replicate the rowing stroke have been formulated. Solutions based on linear actuators or an industrial robotic arm are currently taken into consideration. Also two-dimensional numerical simulations are carried out to obtain insight in the vortex structures shed by the oar blade.

DISSERTATIONS

-

SCIENTIFIC PUBLICATIONS

-

PROJECTLEADERS

J Westerweel, MJ Tummers

RESEARCHTHEME

Complex dynamics of fluids

PARTICIPANTS

EJ Grift

COOPERATIONS

Koninklijke Nederlandse Roeibond, (KNRB), Koninklijke Nederlandse Zwembond (KNZB), Technologiestichting (STW), TU Eindhoven, VU Amsterdam

FUNDED

| | |
|---|------|
| STW, KNRB, KNZB, InnosportLab. University | - |
| FOM | - |
| STW | 50 % |
| NWO Other | - |
| Industry | 50 % |
| TNO | - |
| GTI | - |
| EU | - |
| Scholarships | - |

START OF THE PROJECT

2014

INFORMATION

EJ Grift
015 278 1123
e.j.grift@tudelft.nl
pe.tudelft.nl

INVESTIGATING FLOW STRUCTURES OF DIFFERENT TURBULENT AND TRANSITIONAL FLOW STATES IN CANONICAL FLOWS

PROJECT LEADERS

J Westerweel

RESEARCH THEME

Complex dynamics of fluids

PARTICIPANTS

GE Elsinga

COOPERATIONS

-

FUNDED

FOM

University -

FOM 100 %

STW -

NWO Other -

Industry -

TNO -

GTI -

EU -

Scholarships -

START OF THE PROJECT

2014

INFORMATION

M Gul

06 44084160

M.Gul@tudelft.nl

PROJECT AIM

Research objective is to employ tomographic particle image velocimetry (tomo-PIV) for detailed flow structure analysis of different turbulent and transitional flow states in canonical flows, and explore the parameter space in search of different turbulent states and their characterization.

PROGRESS

Research objective is to employ tomographic particle image velocimetry (tomo-PIV) for detailed flow structure analysis of different turbulent and transitional flow states in canonical flows, and explore the parameter space in search of different turbulent states and their characterization.

DISSERTATIONS

-

SCIENTIFIC PUBLICATIONS

-

HYDRODYNAMICS OF MINIMAL BIOLOCOMOTION

PROJECT AIM

Experimental investigation of the mechanisms responsible for the synchronous motion of cilia and flagella. The behavior of the unicellular algae *C. reinhardtii* is studied in presence of a periodic background flow. This allows to properly characterize how the hydrodynamic interaction of flagella and flow affects synchronization. Subsequently more local flow perturbations will be imposed on the cell to characterize the mechanical coupling between the two flagella.

PROGRESS

Improvement in the setup and in the acquisition and imaging allowed extensive data acquisition. The behavior of flagella in presence of many different oscillatory flow patterns has been observed. A theoretical modelling of the behavior of this organism as a self-sustained oscillator is being developed.

DISSERTATIONS

-

SCIENTIFIC PUBLICATIONS

-

PROJECT LEADERS

J Westerweel, DSW Tam

RESEARCH THEME

Mathematical and computational methods for fluid flow analysis

PARTICIPANTS

G Quaranta

COOPERATIONS

-

FUNDED

TU Delft (Lab Aero & Hydro Dynamics0

University 100 %

FOM -

STW -

NWO Other -

Industry -

TNO -

GTI -

EU -

Scholarships -

START OF THE PROJECT

2013

INFORMATION

G Quaranta

06 31572642

G.Quaranta@tudelft.nl

INVESTIGATION OF HEAT TRANSFER TO TURBULENT SUPERCRITICAL FLUIDS BY MEANS OF DIRECT NUMERICAL SIMULATION

PROJECT LEADERS

M Rohde

RESEARCH THEME

Mathematical and computational methods for fluid flow analysis

PARTICIPANTS

JWR Peeters, BJ Boersma,
R Pecnik, THJJ van der Hagen,
M Rohde

COOPERATIONS

-

FUNDED

| | |
|--------------|-------|
| STW-OTP | |
| University | - |
| FOM | - |
| STW | 100 % |
| NWO Other | - |
| Industry | - |
| TNO | - |
| GTI | - |
| EU | - |
| Scholarships | - |

START OF THE PROJECT

2012

INFORMATION

JWR Peeters
015 278 6628
j.w.r.peeters@tudelft.nl
<http://pe.tudelft.nl/node/603>

PROJECT AIM

Heat transfer to supercritical fluids shows exotic behaviour, due to sharp fluid property gradients with respect to the temperature. As a result, it is difficult, if not impossible, to accurately predict heat transfer to such fluids using simple heat transfer relations. The goal of this project is to investigate the complex physics involved and to develop an accurate design correlation for the prediction of heat transfer to supercritical fluids. With Direct Numerical Simulations, it is possible to investigate the physics involved in great detail. These investigations will then be used for the design of a heat transfer relation.

PROGRESS

Three different numerical cases are currently considered. In case I, all thermo-physical properties are constant, while in cases II and III, the properties correspond to that of CO₂ at 8MPa. Upward mixed convection effects are considered only case III. The CO₂ cases have considerable property fluctuations, such that turbulence intensities are attenuated. The variations in thermo-physical properties are found to have a clear effect on near wall turbulent structures. In the forced convection case, the stream-wise vorticity structures are less apparent, while in the mixed convection case, the stream-wise vortices seem to have mostly disappeared near wall. Streaks become smaller in the forced convection case, while the opposite is true for the mixed convection case. This suggests that the near wall mechanism for sustaining turbulence is affected by the variable thermo-physical properties. This is currently under investigation.

DISSERTATIONS

-

SCIENTIFIC PUBLICATIONS

1. Peeters, J.W.R.; Pecnik, R.; Boersma, B.J.; Rohde, M.; van der Hagen, T. H. J. J.; Direct Numerical Simulation of heat transfer to CO₂ in an annulus at supercritical pressure; In proceedings of the 10th International ERCOFTAC Symposium on Engineering Turbulence Modelling and Measurements, Marbella, Spain, 17-19 September 2014.

UPSCALING EXPLOSION SEVERITY PARAMETERS FROM LABORATORY TO INDUSTRIAL SCALE

PROJECT AIM

Despite tremendous research efforts in the last 30 years, dust explosions continue to pose a serious threat to the process industries. The aim of this project is to investigate the effect of scale, turbulence, and ignition energy on the explosion severity of dust explosions using different types of fuels. Explosion tests are carried out in a 20 L sphere and in a 1 m³ vessel.

PROGRESS

A project plan for the PhD study has been developed. Explosion tests have been engaged early this year. Preliminary results indicate that scale, turbulence, and ignition energy may have different effects depending on the nature of the dust and its specific combustion behavior (gas phase or solid phase). For example, some dusts give rise to more severe explosions in the 20 L sphere, and some others in the 1 m³ vessel. Others exhibit the same explosion severity in both vessels. Scale, turbulence and ignition energies will be systematically varied for several fuels. Combustion behavior will also be investigated thanks to highspeed recordings of flame propagation in a transparent tube.

DISSERTATIONS

-

SCIENTIFIC PUBLICATIONS

-

PROJECT LEADERS

DJEM Roekaerts

RESEARCH THEME

Complex dynamics of fluids

PARTICIPANTS

J Taveau

COOPERATIONS

SM Lemkowitz (TUD ChemE),

AE Dahoe (Univ. Ulster), Fike

Corporation

FUNDED

Fike Corporation

University -

FOM -

STW -

NWO Other -

Industry 100 %

TNO -

GTI -

EU -

Scholarships -

START OF THE PROJECT

2014

INFORMATION

J Taveau

(+1) 816 655 4769

jerome.taveau@fike.com

DEVELOPMENT OF AN ACCURATE DESIGN CORRELATION FOR SUPERCRITICAL HEAT TRANSFER APPLICATIONS

PROJECT LEADERS

M Rohde, THJJ van der Hagen,
J Westerweel

RESEARCH THEME

Complex dynamics of fluids

PARTICIPANTS

V Valori, J Peeters, M Rohde, G
Elsinga, R Pecnik, J Westerweel,
BJ Boersma, T van der Hagen

COOPERATIONS

Cooperation between the Faculty
of Mechanical Engineering (groups
of Fluid Mechanics and Energy
Technology) and Applied Sciences
(group of Nuclear Energy and
Radiation Applications) of TU Delft.

FUNDED

| | |
|--------------|-------|
| STW | |
| University | - |
| FOM | - |
| STW | 100 % |
| NWO Other | - |
| Industry | - |
| TNO | - |
| GTI | - |
| EU | - |
| Scholarships | - |

START OF THE PROJECT

2013

INFORMATION

V Valori
015 278 9111
v.valori@tudelft.nl

PROJECT AIM

This project aims to develop an accurate, physically sound design correlation for heat transfer in supercritical fluids. The correlation should prevent expensive oversizing of industrial equipment (required to avoid overheating) and stimulate the production of better products and more efficient processes.

PROGRESS

Study of Non-Boussinesq conditions in a Rayleigh-Benard cell at atmospheric pressure, in order to analyze the effect of variable properties on the fluid flow and turbulence. This is a preliminary study on the effect of variable property in preparation to the most complex case of fluid at supercritical pressure, where the effect of variable properties is stronger. PIV experiments in a Rayleigh Benard cell at non Boussinesq conditions: measurements of the mean velocities, of the RMS of the velocity components, of the turbulent kinetic energy and of the shear stress. The experiments has been done with three different fluids: water, methanol and Acetone, in order to study the effect of different Pr numbers on the fluid flow.

DISSERTATIONS

-

SCIENTIFIC PUBLICATIONS

-

TURBULENT FLOW AND HEAT TRANSFER NEAR THE CRITICAL POINT OF CO₂ USING DIRECT NUMERICAL SIMULATION (DNS)

PROJECT AIM

Experimental studies showed that heat transfer to supercritical fluids can exhibit dramatic heat transfer deterioration or enhancement, which makes it different from those in subcritical pressure. These phenomena lead to the presence of local minima/maxima in heat transfer coefficients or wall temperatures along a heated surface. In nuclear reactors the prediction of wall temperature is of paramount to improve the safety and performance of the nuclear power plants. The objective of the current study is to further investigate the turbulent heat transfer mechanisms to supercritical fluids in pipe flows using detailed turbulent flow statistics.

PROGRESS

Three different cases, one forced convection (case A) and two upward mixed convection with low (case B) and high (case C) buoyancy, with supercritical CO₂ at thermodynamic pressure $P_0=8\text{MP}$ have been simulated and analyzed. Results show that for case A thermal expansion causes a reduction in turbulent kinetic energy in the downstream direction while in case B the trend of turbulent statistics is the same as that of case A, but with a higher reduction in turbulence. In case C, the deterioration of heat transfer is followed by a recovery of turbulence. In case C the reduction of turbulent kinetic energy followed by recovery region in downstream. Another case is to study the effects of different wall boundary conditions (isoflux and isothermal) for case A. Results show that there is a considerable reduction in global heat transfer when the wall boundary changes from isoflux to isothermal.

DISSERTATIONS

-

SCIENTIFIC PUBLICATIONS

1. Rene Pecnik, Hassan Nemati, Ashish Patel, Bendiks Jan Boersma, "The effect of large property fluctuations on turbulent heat transfer to supercritical pressure fluids in pipes." Bulletin of the American Physical Society 59 (2014).

PROJECT LEADERS

BJ Boersma, R Pecnik

RESEARCH THEME

Mathematical and computational methods for fluid flow analysis

PARTICIPANTS

H Nemati, A Patel, R Pecnik,
BJ Boersma

COOPERATIONS

TUD

FUNDED

| | |
|--------------|-------|
| TU Delft | |
| University | 100 % |
| FOM | - |
| STW | - |
| NWO Other | - |
| Industry | - |
| TNO | - |
| GTI | - |
| EU | - |
| Scholarships | - |

START OF THE PROJECT

2012

INFORMATION

H Nemati

015 278 2186

h.nemati@tudelft.nl

PROJECT LEADERS

TJC van Terwisga, J Westerweel,
R Delfos

RESEARCH THEME

Complex dynamics of fluids

PARTICIPANTS

PC Pennings

COOPERATIONS

Part of the International Institute
for Cavitation Research (IICR),
cooperation with the Dynamics of
Vortex Cavitation on Ship and Pump
Impellers (DYNVOR) and the STW
Ship Drag Reduction projects

FUNDED

Entirely funded by the Lloyd's
Register Educational Trust

| | |
|--------------|-------|
| University | - |
| FOM | - |
| STW | - |
| NWO Other | - |
| Industry | 100 % |
| TNO | - |
| GTI | - |
| EU | - |
| Scholarships | - |

START OF THE PROJECT

2011

INFORMATION

PC Pennings
015 278 8351
p.c.pennings@tudelft.nl
pe.tudelft.nl

PROJECT AIM

These vortices flow past rudders they could induce severe erosion. Ideally these harmful results should be prevented in the design stage. To be able to quantify sound emission and erosion more understanding is needed of the dynamics of cavitating vortices. Therefore the aim of this project is to first study the dynamics and sound emission of a cavitating vortex in isolation. Second is the study of the interaction of multiple vortices possibly near a surface. The final goal is to recreate a cavitating tip vortex besides a rudder and determine erosive properties.

PROGRESS

Tip vortices are flow structures with concentrated vorticity which can persist far downstream of a propeller. A simplified case of a cavitating vortex trailing the tip of a stationary blade at incidence is studied. High speed video recordings combined with force and acoustic measurements have been used to better understand the dynamics that consist of waves on the interface between liquid and water vapour. Comparison to an analytic model of tip vortex cavity core vibrations has provided insight in the presence of different wave modes and their transport. This was quantitatively supported by Stereo Particle Image Velocimetry measurements for the same conditions.

DISSERTATIONS

-

SCIENTIFIC PUBLICATIONS

-

FLUID DYNAMICS OF FLOWS EVOLVING CLOSE TO THE LIQUID-VAPOR CRITICAL POINT

PROJECT AIM

The aim of the project is the study, modeling, and simulation of compressible flows evolving close to the liquid-vapor critical point. This thermodynamic region is very attractive for the new generation energy conversion systems. The improvement numerical schemes for RANS simulations of real fluids is the prime focus. The application of the newly developed techniques is turbomachinery of organic Rankine cycles and supercritical CO₂ Brayton cycles turbines. The linear stability analysis of laminar flows of thermally stratified fluids with temperature-dependent thermophysical properties is also part of the project.

PROGRESS

The advancements on numerical flux and Jacobians evaluation for real fluids were published in [1]. The methodology was applied to compute the performance map of a sCO₂ compressor. Preliminary results were presented in [2] and improved calculations were published in the J. Eng. Gas Turb. Power (2015) and show good agreement with experimental data. The off-design operation of a high expansion ratio ORC turbine is currently under investigation by means of 2D unsteady RANS simulations. In order to perform such simulations, a flux-conservative interface treatment of sliding mesh patches was developed. The influence of temperature-dependent thermal conductivity and isobaric specific heat on the linear stability of a laminar flow under a temperature gradient is also under study at the moment.

DISSERTATIONS

-

SCIENTIFIC PUBLICATIONS

1. Rinaldi, E., Pecnik, R., & Colonna, P., Exact Jacobians for implicit Navier-Stokes simulations of equilibrium real gas flows, *J. Comput. Phys.*, 270, (2014), 459-477.
2. Rinaldi, E., Pecnik, R., & Colonna, P., Numerical computation of the performance map of a supercritical CO₂ radial compressor by means of three dimensional CFD simulations, *Proceedings of the ASME Turbo Expo*, (2014).
3. Rinaldi, E., Suarez Raspopov, R., Colonna, P., & Pecnik, R., Modeling curvature effects on turbulence transition for turbomachinery flows, *Proceedings of the ASME Turbo Expo*, (2014).
4. Guardone, A., Colonna, P., Casati, E., & Rinaldi, E., Non-classical gas dynamics of vapour mixtures, *J. Fluid Mech.*, 741 (2014) 681-701.

PROJECT LEADERS

R Pecnik, P Colonna

RESEARCH THEME

Mathematical and computational methods for fluid flow analysis

PARTICIPANTS

E Rinaldi, R Pecnik, P Colonna

COOPERATIONS

-

FUNDED

| | |
|--------------|-------|
| TU Delft | |
| University | 100 % |
| FOM | - |
| STW | - |
| NWO Other | - |
| Industry | - |
| TNO | - |
| GTI | - |
| EU | - |
| Scholarships | - |

START OF THE PROJECT

2011

INFORMATION

R Pecnik

015 278 9153

r.pecnik@tudelft.nl

PROJECT LEADERS

G Ooms, RAWM Henkes,
J Westerweel

RESEARCH THEME

Mathematical and computational
methods for fluid flow analysis

PARTICIPANTS

MJMB Pourquie, SM Park

COOPERATIONS

-

FUNDED

P&E Department
University 100 %
FOM -
STW -
NWO Other -
Industry -
TNO -
GTI -
EU -
Scholarships -

START OF THE PROJECT

2014

INFORMATION

G Ooms
015 278 1176
g.ooms@tudelft.nl
www.gjjsooms.nl

PROJECT AIM

To study the fluid-mechanical aspects of core-annular flow in a curved pipe.

PROGRESS

1) A numerical study, using the volume of fluid method, has been made of laminar core annular flow in a 90° bend. Special attention was given to the influence of the secondary flow perpendicular to the pipe axis.

2) A numerical study has also been made of the laminar core-annular flow through a torus. It is a follow-up of a study given in the literature, in which an analytical solution is given for the case that the core is concentric and circular. We found that also a stable eccentric core position is possible, which was shifted in the direction of the inner – or outer side of the torus depending on the balance of the normal stresses at the core-annular interface.

3) A design has been made of an experimental set-up.

DISSERTATIONS

-

SCIENTIFIC PUBLICATIONS

1. J.C. Beerens, G. Ooms, M.J.B.M. Pourquie and J. Westerweel, A comparison between numerical predictions and theoretical and experimental results for core-annular flow, AIChE Journal 60 (no. 8), (2014), 3046-3056.

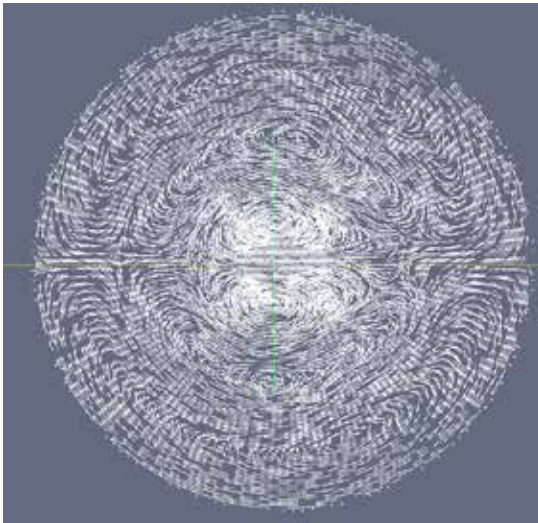

FLAMELESS COMBUSTION CONDITIONS AND EFFICIENCY IMPROVEMENT OF SINGLE- AND MULTI-BURNER-FLOXTM FURNACES IN RELATION TO CHANGES IN FUEL AND OXIDIZER COMPOSITION (FLEXFLOX). PART 1A: EXPERIMENTAL STUDIES IN SINGLE-BURNER SYSTEMS

PROJECT AIM

The objective of the flexFLOX project is to investigate both experimentally and computationally the impact of changes in fuel and oxidizer composition on flameless combustion. To reach the flameless combustion regime the air (and/or fuel) streams are diluted with hot combustion products with a temperature sufficiently high for the combustion process to be stable and occurring in a distributed reaction zone. The objective of part 1a of the project is gaining fundamental understanding of the flameless regime via laser diagnostic experiments in single burner systems, in particular the Delft jet-in-hot-coflow (DJHC) burner operated with different fuels.

PROGRESS

Two data sets of flame luminescence at the flame stabilization region of natural-gas jet-in-hot-coflow flames were generated for flames with different hydrogen concentrations in the fuel and different coflow conditions. All the fuel jets reported here have a fixed Reynolds number of 5600 and Dutch Natural Gas (DNG) is used as base fuel. The first set contains flames with hydrogen concentrations from 0% to 55%, issued into an identical coflow (see figure). The second set has flames with a fuel jet containing 25% of hydrogen, issued into six different coflow conditions with different adiabatic temperatures. The calculated adiabatic temperatures in the coflows range from 1580 K to 1030 K. It is found that a flame stabilisation mechanism by ignition kernels, typical for flameless combustion, can be maintained even in the presence of high hydrogen concentration, provided the coflow temperature is lowered. This suggests that hydrogen containing fuels could be used with traditional flameless oxidation equipment if the process temperature is reduced.

DISSERTATIONS

-

SCIENTIFIC PUBLICATIONS

1. L.D. Arteaga Mendez, E.H. van Veen, M.J. Tummerts and D.J.E.M. Roekaerts, Effect of hydrogen addition on the structure of natural-gas jet-in-hot-coflow flames, Proceedings of the Combustion Institute, 2014, <http://dx.doi.org/10.1016/j.proci.2014.06.146>.
2. L.D. Arteaga Mendez, E. H. van Veen, M.J. Tummerts and D.J.E.M. Roekaerts Effect of H₂ and CO₂ on the stabilization mechanism of jet flames Abstract of poster presentation at the 12th Int. Workshop on Measurement and Computation of Turbulent Flames (TNF12), Pleasanton, California, July 31-August 2, 2014 (poster 3).
3. L.D. Arteaga Mendez, E. H. van Veen, M.J. Tummerts and D.J.E.M. Roekaerts Effect of H₂ and CO₂ on the stabilization mechanism of jet flames In : Book of Abstracts, Combura Symposium, October 8-9, 2014, Soesterberg, Published by Technology Foundation STW, Utrecht, The Netherlands, Pages 27-28.

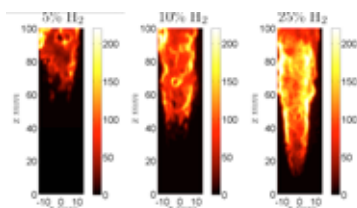

PROJECT LEADERS

DJEM Roekaerts, MJ Tummerts,
W de Jong

RESEARCH THEME

Complex dynamics of fluids

PARTICIPANTS

LD Arteaga Mendez, EH van Veen

COOPERATIONS

WS-Prozesstechnik, Stuttgart
TNO glass group (Celsian BV)
Tata Steel, Numeca Int., Brussels

FUNDED

Technology Foundation STW, Tata
Steel, Shell, NVV, Numeca Int., TNO
University -
FOM -
STW 80 %
NWO Other -
Industry 15 %
TNO 5 %
GTI -
EU -
Scholarships -

START OF THE PROJECT

2009

INFORMATION

MJ Tummerts
015 278 2477
m.j.tummerts@tudelft.nl
www.cleancombustionconcepts.nl

FLAMELESS COMBUSTION CONDITIONS AND EFFICIENCY IMPROVEMENT OF SINGLE- AND MULTI-BURNER-FLOXTM FURNACES IN RELATION TO CHANGES IN FUEL AND OXIDIZER COMPOSITION (FLEXFLOX). PART 2: INVESTIGATIONS OF A MULTI-BURNER FURNACE

PROJECT LEADERS

W de Jong, DJEM Roekaerts,
MJ Tummers

RESEARCH THEME

Complex dynamics of fluids

PARTICIPANTS

Lu Jie (CSC), S Keizer

COOPERATIONS

WS-Prozesstechnik, Stuttgart
TNO glass group (Celsian BV)
Tata Steel, Numeca Int., Brussels

FUNDED

Technology Foundation STW, Tata
Steel, Shell, NVV, Numeca Int., TNO
University -
FOM -
STW 80 %
NWO Other -
Industry 15 %
TNO 5 %
GTI -
EU -
Scholarships -

START OF THE PROJECT

2009

INFORMATION

W de Jong
015 278 9476
wiebren.dejong@tudelft.nl
www.cleancombustionconcepts.nl

PROJECT AIM

The objective of the flexFLOX project is to investigate both experimentally and computationally the impact of changes in fuel and oxidizer composition on flameless combustion. To reach the flameless combustion regime the air (and/or fuel) streams are diluted with hot combustion products with a temperature sufficiently high for the combustion process to be stable and occurring in a distributed reaction zone. The objective of part 2 of the flexFLOX project is to do experimental and computational studies of a multi-burner FLOX furnace (MEEC furnace).

PROGRESS

The objective of the flexFLOX project is to investigate both experimentally and computationally the impact of changes in fuel and oxidizer composition on flameless combustion. To reach the flameless combustion regime the air (and/or fuel) streams are diluted with hot combustion products with a temperature sufficiently high for the combustion process to be stable and occurring in a distributed reaction zone. The objective of part 2 of the flexFLOX project is to do experimental and computational studies of a multi-burner FLOX furnace (MEEC furnace).

DISSERTATIONS

-

SCIENTIFIC PUBLICATIONS

1. Jie Lu, Sjoerd Keizer, Wiebren de Jong, and Dirk J.E.M. Roekaerts
Measurements of species concentrations in a multiburner FLOX furnace
In : Book of Abstracts, Combura Symposium, October 8-9, 2014, Soesterberg,
Published by Technology Foundation STW, Utrecht, The Netherlands, page 43.

FLAMELESS COMBUSTION CONDITIONS AND EFFICIENCY IMPROVEMENT OF SINGLE- AND MULTI-BURNER-FLOXTM FURNACES IN RELATION TO CHANGES IN FUEL AND OXIDIZER COMPOSITION (FLEXFLOX). PART 1B: COMPUTATIONAL STUDIES OF THE JET-IN-HOT-COFLOW BURNER

PROJECT AIM

The objective of the flexFLOX project is to investigate both experimentally and computationally the impact of changes in fuel and oxidizer composition on flameless combustion. To reach the flameless combustion regime the air (and/or fuel) streams are diluted with hot combustion products with a temperature sufficiently high for the combustion process to be stable and occurring in a distributed reaction zone. The objective of part 1b of the project is to develop and validate computational models using the Delft Jet-in-Hot-Coflow (DJHC) burner as a model system.

PROGRESS

The structure of turbulent non-premixed flames of natural gas and of synthetic biogas in the DJHC burner has been studied numerically. Biogas fuel is obtained by dilution of Dutch natural gas (DNG) with CO₂. Numerical simulations are conducted by solving the RANS equations using Reynolds stress model (RSM) as turbulence model in combination with EDC (Eddy Dissipation Concept) and transported probability density function (PDF) as turbulence-chemistry interaction models. The DRM19 reduced mechanism is used as chemical kinetics with the EDC model. A tabulated chemistry model based on the Flamelet Generated Manifold (FGM), based on igniting counterflow diffusion flames, is adopted in the PDF method. The EDC/DRM19 and PDF/FGM models predict the experimentally observed decreasing trend of lift-off height with increase of the coflow temperature. Although more detailed chemistry is used with EDC, the temperature fluctuations at the coflow inlet (approximately 100K) cannot be included resulting in a significant overprediction of the flame temperature. Only the PDF modeling results with temperature fluctuations predict the correct mean temperature profiles of the biogas case and compare well with the experimental temperature distributions.

DISSERTATIONS

-

SCIENTIFIC PUBLICATIONS

1. G. Sarras, Y. Mahmoudi, L.D. Arteaga Mendez, E.H. van Veen, M.J. Tummers, and D.J.E.M. Roekaerts, Modeling of Turbulent Natural Gas and Biogas Flames of the Delft Jet-in-Hot-Coflow Burner: Effects of Coflow Temperature, Fuel Temperature and Fuel Composition on the Flame Lift-Off Height, Flow, Turbulence and Combustion, 2014, 93: 607-635, <http://dx.doi.org/10.1007/s10494-014-9555-3>.
2. G. Sarras and D.J.E.M. Roekaerts, PDF modeling of biogas flames of the Delft jet-in-hot-coflow burner including FGM tabulated chemical kinetics, Abstract of poster presentation at the 12th Int. Workshop on Measurement and Computation of Turbulent Flames (TNF12), Pleasanton, California, July 31- August 2, 2014 (poster 34).

PROJECTLEADERS

DJEM Roekaerts, MJ Tummers,
W de Jong

RESEARCHTHEME

Complex dynamics of fluids

PARTICIPANTS

G Sarras, Y Mahmoudi

COOPERATIONS

-

FUNDED

Technology Foundation STW, Tata
Steel, Shell, NVV, Numeca Int., TNO
University -
FOM -
STW 80 %
NWO Other -
Industry 15 %
TNO 5 %
GTI -
EU -
Scholarships -

START OF THE PROJECT

2010

INFORMATION

GSarras
015 278 2186
g.sarras@tudelft.nl
www.cleancombustionconcepts.nl



PROJECT LEADERS

MJ Tummers, DJEM Roekaerts

RESEARCH THEME

Complex dynamics of fluids

PARTICIPANTS

HRC Rodrigues

COOPERATIONS

TH van der Meer (U Twente)

S Zhu (U Twente)

FUNDED

Technology Foundation STW
(CCC program), Stork Thermeq,

Shell

University -

FOM -

STW 80 %

NWO Other -

Industry 20 %

TNO -

GTI -

EU -

Scholarships -

START OF THE PROJECT

2010

INFORMATION

MJ Tummers

015 278 2477

m.j.tummers@tudelft.nl

www.cleancombustionconcepts.nl

PROJECT AIM

This project concerns the extension of the application of High Temperature Air Combustion (HiTAC) to heavy-oil combustion processes in a boiler and is a joint project of University Twente and Delft University of Technology. To generate the knowledge needed to be able to develop and design such a boiler, experimental and computational investigations will be made of turbulent spray flames under HiTAC conditions. At TU Delft, an experimental study of spray flames of light fuel oil burning in a co-flow of hot air diluted with combustion products will provide detailed knowledge of the relations between atomization process, ignition, entrainment and burnout.

PROGRESS

This project concerns the extension of the application of High Temperature Air Combustion (HiTAC) to heavy-oil combustion processes in a boiler and is a joint project of University Twente and Delft University of Technology. To generate the knowledge needed to be able to develop and design such a boiler, experimental and computational investigations will be made of turbulent spray flames under HiTAC conditions. At TU Delft, an experimental study of spray flames of light fuel oil burning in a co-flow of hot air diluted with combustion products will provide detailed knowledge of the relations between atomization process, ignition, entrainment and burnout.

DISSERTATIONS

-

SCIENTIFIC PUBLICATIONS

1. Hugo Correia Rodrigues, Mark J. Tummers, Eric H. van Veen, Dirk J.E.M. Roekaerts, Spray flame structure in conventional and hot-diluted combustion regime, *Combustion and Flame*, 2014. <http://dx.doi.org/10.1016/j.combustflame.2014.07.033>.
2. H. Correia Rodrigues, M.J. Tummers, E.H. van Veen, D.J.E.M. Roekaerts, Effects of coflow temperature and composition on ethanol spray flames in hot-diluted coflow, *Int. J. Heat Fluid Flow*, 2014, <http://dx.doi.org/10.1016/j.ijheatfluidflow.2014.10.006>.
3. L. Ma, H.R. Correia Rodrigues, S. Zhu, M.J. Tummers, D.J.E.M. Roekaerts, Modelling of Delft Spray-in-Hot-Coflow flame with steady flamelet and FGM, in *Book of Abstracts of the 23rd Biennial Meeting of the Belgian Section of the Combustion Institute, Brussels, 27-28 May, 2014*, 2 pages.

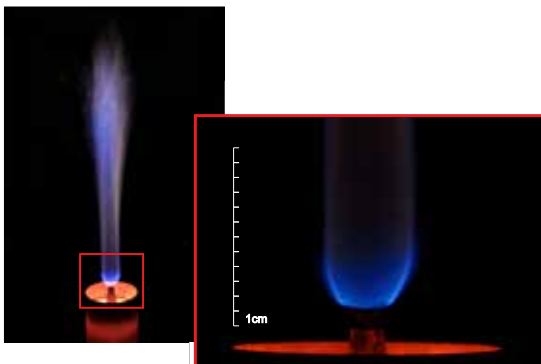

EXPERIMENTAL STUDY OF TURBULENT COMBUSTION IN A SINGLE BURNER FURNACE

PROJECT AIM

The objective of the project is to get better fundamental understanding of flameless combustion. Specifically, the project aims to determine the effects of fuel composition, operational conditions and nozzle geometry on the flameless combustion process in a single-burner furnace. From visualization of the reactions zones in the furnace and analysis of the flue gas composition it will be determined under which conditions the flameless combustion regime can be established in the single-burner furnace. A selected set of flames will then be studied in greater detail by measuring the velocity fields with PIV/LDA, the temperature with CARS and OH concentration with PLIF.

PROGRESS

The design of the Delft single-burner furnace (DSBF) has as original aspect the possibility to move the burner position and the top wall. In this way the quartz windows and the laser diagnostic equipment can remain fixed in the laboratory frame, enabling fast and reliable measurements.

All components for this furnace with full optical access for laser diagnostics are ready and it is currently under construction. The operation of a WS-FLOX® burner has already been tested in a furnace without optical access (see figure). The combustion mode was successfully switched from FLAME mode to FLOX® mode without quenching. Temperature was continuously monitored using K type thermocouples. The combustion process in the DSBF was computed with the steady flamelet model and the Flamelet Generated Manifold (FGM) model. The results show that highspeed air jets are beneficial for forming flue gas recirculation and the establishment of flameless combustion. Steady flamelet and FGM models with flamelets based on fuel and air as pure streams were found to lead to over prediction of temperature and are not sufficiently accurate for modelling flameless combustion. Modelling is continuing with the eddy-dissipation-concept (EDC) model.

DISSERTATIONS

-

SCIENTIFIC PUBLICATIONS

1. X. Huang, M.J. Tummers and D.J.E.M. Roekaerts. Study of flameless combustion in Delft single-burner furnace (DSBF) In : Book of Abstracts, Combura Symposium, October 8-9, 2014, Soesterberg, Published by Technology Foundation STW, Utrecht, The Netherlands, p 43.

PROJECTLEADERS

MJ Tummers, DJEM Roekaerts

RESEARCHTHEME

Complex dynamics of fluids

PARTICIPANTS

Xu Huang

COOPERATIONS

WS GmbH

FUNDED

China Scholarship Council

University -

FOM -

STW -

NWO Other -

Industry -

TNO -

GTI -

EU -

Scholarships 100 %

START OF THE PROJECT

2013

INFORMATION

X Huang

015 278 6745

x.huang-2@tudelft.nl



PROJECT LEADERS

DJEM Roekaerts

RESEARCH THEME

Mathematical and computational methods for fluid flow analysis

PARTICIPANTS

L Ma

COOPERATIONS

B Naud, CIEMAT, Madrid

FUNDED

China Scholarship Council

University -

FOM -

STW -

NWO Other -

Industry -

TNO -

GTI -

EU -

Scholarships 100 %

START OF THE PROJECT

2012

INFORMATION

L Ma

015 278 6745

l.ma@tudelft.nl

PROJECT AIM

Spray flames widely used in industrial furnaces, power generation system, etc. and there is a need for computational model to predict their properties. The objective is to develop and validate accurate and efficient modeling approaches for turbulent spray combustion. The models should describe the main physical and chemical processes, notably phase change, turbulence, chemical reaction and radiation and their mutual interactions. Models will be developed for dilute spray combustion and for the coupling between dense spray and dilute spray regions.

PROGRESS

Computational studies have been made of the Delft Spray in Hot Coflow (DSHC) ethanol flame. Our approach has three stages, increasing in accuracy and complexity. In the first two stages, 'Eulerian-Lagrangian' and 'Lagrangian-Lagrangian' simulations have been conducted, respectively with the commercial software ANSYS Fluent and the in-house hybrid finite volume/transported PDF code 'PDFD'. Especially with the latter approach good results were obtained, remaining inaccuracies are mainly due to uncertainty in inlet boundary conditions and the limitations of the model for enthalpy fluctuations. In the third stage of the project, to achieve a better representation on the dynamical characteristics of the flame, and a more accurate description of the structure of the reacting two-phase flow, Large Eddy Simulation is carried out using OpenFoam as CFD framework. As a start the Flamelet Generated Manifolds (FGM) model has been implemented in the latest version of OpenFoam. Successful simulation of two well-documented gaseous flames, Sandia flame D and the Cabra lifted methane/air flame, has confirmed the correctness of this code development. Next, spray models will be added. (The figure shows a snapshot of the liquid atomization process).

DISSERTATIONS

-

SCIENTIFIC PUBLICATIONS

1. Likun Ma, Hugo Correia Rodrigues, Bertrand Naud, E.H. van Veen, Mark Tummers and Dirk Roekaerts, Transported PDF modeling of ethanol spray in hot-diluted coflow flame, Abstract of Work-in-Progress poster. In: Proceedings of the Thirty-Fourth International Symposium on Combustion, San Francisco, August 3-8, 2014 (W3P023).
2. L. Ma, B. Naud and D.J.E.M. Roekaerts, Modeling ethanol spray jet flame in hot-diluted coflow with transported PDF, In: Proceedings of SPEIC14 – Towards Sustainable Combustion, Lisbon, November 19-21, 2014, paper 109, 6 pages.

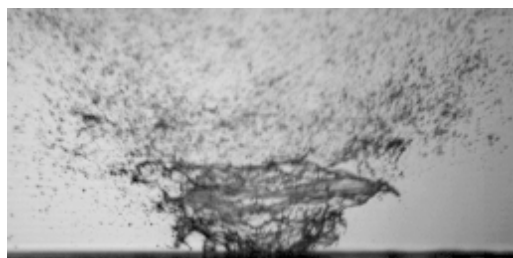



Prof.dr.ir. RHM Huijsmans



Prof.dr.ir. TJC van Terwisga

SEAKEEPING AND MANOEUVRING - PROF. RHM HUIJSMANS

Research of the Chair of Ship motions and manoeuvring is at present focused on the following areas: 1. Non-linear behaviour of fast craft in waves; 2. Extreme wave events in relation to stationary floating structures; 3. Very Large Floating Structures at sea; 4. Prediction of manoeuvring forces based on CFD methods.

High speed ships traveling in waves experience large amplitude motions which can lead to strong non-linear effects in the loads on the hull girder. These non-linear effects are due partly to the large changes in the wetted part of the hull in waves and partly due to non-linear pressure effects. Extreme wave events (breaking waves etc.) can lead to high impact loads on stationary floating structures, e.g. bow loads on Floating Production and Storage vessels for the oil industry. Hydrodynamic analysis of such behaviour is now moving towards application of CFD methods to determine the local flow at the bow. In order to simulate open sea conditions, the CFD region will be connected to an outer region which will be described by potential flow methods. This will allow waves to enter the region local to the bow and reflected waves to travel away from the bow thus minimizing reflections from the CFD boundary. Very Large Floating Structures are being investigated world-wide for various applications such as airports and for floating cities. This research is aimed at developing a novel concept of a large floating structure based on the use of air cushions to support the structure and distribute the wave loads thus optimizing both motion behaviour and structural costs. Manoeuvring models for ships have traditionally been based on equations of motions using experimentally determined drag, mass and lift coefficients. This research aims to investigate the applicability of CFD methods in determining the hydrodynamic coefficients for existing mathematical models. Use is made of a RANS code developed by MARIN and modified to accommodate oblique flow.

PROPULSION AND RESISTANCE - PROF. T VAN TERWISGA (PART TIME)

Research at the Chair of propulsion and resistance is focussed on three areas: 1. Cavitating Flows; 2. Ship-Propeller-Engine system in Service Conditions; 3. Drag reduction through air lubrication.

Cavitation remains an important field of investigation in Marine Technology. Almost all propellers in operation show cavitation in some but mostly in all working conditions. Cavitation often is an important source of vibrations and sometimes even cavitation erosion. Cavitation on propellers should therefore be controlled as much as possible in both the design and during operations. As cavitation often appears to be extremely unsteady and unstable, this poses a continuing challenge to designers and research groups. The more so because an acceptable cavitation control and a high propulsive efficiency are often conflicting requirements. The Delft Cavitation Tunnel has proven to be a strategic tool for enhancing our understanding of the physics and engineering characteristics. There are currently two PhD projects addressing this issue: One on unsteady sheet cavitation (E.J. Foeth) and another on propeller radiated pressure fluctuations (E.v.Wijngaarden). Ship-Propeller-Engine system analysis and simulation is important to reduce e.g. radiated noise from the propeller and to reduce wear of the propulsion system during its operation. To this end, a close cooperation exists with the section of Marine Engineering. There is currently a PhD project concerned with the development of a model podded propeller for testing in operational conditions (G. Oosterhuis), and a recent PhD project on improved propulsion control for Naval Vessels (A.Vrijdag). Initiatives in the third area on Drag reduction through air lubrication are currently under way.

ACTIVE MOTION CONTROL OF FAST SHIPS

PROJECT AIM

The aim of the PhD project is to develop an advanced ride control system for fast ships in order to improve its sea keeping behavior. The motions of these ships can be controlled by use of active flaps or interceptors located at the stern of the vessel. This project focuses on the control of these mechanisms by a proactive system that uses wave information at some distance in front of the bow. A very fast onboard simulation routine will be used to find the optimal settings of the control devices to increase the operability of the vessel in a seaway.

PROGRESS

A series of model tests have been performed in the towing tank of the Delft University of Technology to demonstrate the feasibility and the performance of the proactive control system in a real-world environment. The speed of the towing carriage and the deflections of the interceptors were continuously controlled based on the outcome of the real-time response predictions. The measured results obtained during these experiment agree to a large extent to the numerical results that were previously produced in a computer simulation. The model, with the proactive control system, could attain a high average forward speed while the seakeeping behavior was significantly improve in comparison to the benchmark tests without control.

DISSERTATIONS

-

SCIENTIFIC PUBLICATIONS

-

PROJECTLEADERS

RHM Huijsmans, JA Keuning

RESEARCHTHEME

Mathematical and computational methods for fluid flow analysis

PARTICIPANTS

AAK Rijkens

COOPERATIONS

-

FUNDED

IOP Maritiem, TU Delft, Damen Shipyard Group, Ministry of Defense MARIN, Bureau Veritas, Lloyd's Register, Imtech Marine & Offshore, Quantum Controls

University 75 %

FOM -

STW -

NWO Other -

Industry 25 %

TNO -

GTI -

EU -

Scholarships -

START OF THE PROJECT

2011

INFORMATION

AAK Rijkens

015 278 6872

a.a.k.rijkens@tudelft.nl

www.3me.tudelft.nl/mtt



Prof.dr.ir. C van Rhee

Large volumes of sediment are displaced nowadays using different types of dredging equipment. Especially the last decade, large land reclamation projects attained global attention. Examples of these enormous projects are the new airports in Hong Kong and Singapore, the large land reclamations for ports and industry in Singapore, the spectacular projects in Dubai like the palm Islands and “the World” and the Maasvlakte II currently under construction in the Netherlands.

All Dredging processes involve slurry flows and are dominated by erosion, transport and sedimentation under special hydraulic conditions like high volumetric sediment concentration and or high flow velocity.

The research topics within the section of Dredging Engineering are focused on the physical processes encountered during dredging (and mining):

- ♦ Excavation processes of saturated sediments (mechanical, hydraulic or a combination).
- ♦ Hydraulic transportation of sediment water mixtures.
- ♦ Mixing and separation process (like the sedimentation process in a hopper of a Trailing Suction Hopper Dredge)
- ♦ Erosion and settling of sediments.
- ♦ Wear of flow components due to hydraulic transport.

PROJECT AIM

To design a shared-control human-machine interface for controlling remotely operated deep-sea mining vehicles and other ROVs, an in-depth modeling of both the environment and human is needed. Two important issues need to be addressed: the free motion control of a vehicle and its tools (grab excavator, cutter or other) at deep water depth with possible currents, and the contact interaction of the vehicle with other equipment or materials. So the aim is to numerically model the deep-sea excavation process on the seabed.

PROGRESS

Work on modeling of dense rock samples has been improved. The fluid-solid coupling mechanism has been updated. The numerical coupling between discrete element modeling (DEM) and computational fluid dynamics (CFD) is proven to be working well in both the dilute and dense regimes via the liquidized bed simulations. The sensitivity of the performance of Parallel bond model to some key parameters has been tested.

DISSERTATIONS

-

SCIENTIFIC PUBLICATIONS

1. Numerical Methods for Modeling the Rock Cutting Process in Deep Sea Mining
Xiuhan Chen, Sape A Miedema, Cees van Rhee. Proceedings of ASME 2014 33rd International Conference on Ocean, Offshore and Arctic Engineering. 2014, San Francisco, USA.
2. Numerical Modeling of Excavation Process in Dredging Engineering. Xiuhan Chen, Sape A Miedema, Cees van Rhee. Proceedings of The 7th World Congress on Particle Technology (WCPT7), 2014, Beijing, China.

PROJECTLEADERS

C van Rhee, SA Miedema

RESEARCHTHEME

Complex structures of fluids

PARTICIPANTS

X Chen, R Kuiper, T Gibo, SA Miedema, DA Abbink, FCT van der Helm, C van Rhee

COOPERATIONS

Delft University of Technology, Technology Foundation STW, SeaTools B.V., Tree C Technology B.V.

FUNDED

| | |
|---------------------------|-------|
| Technology Foundation STW | |
| University | - |
| FOM | - |
| STW | 100 % |
| NWO Other | - |
| Industry | - |
| TNO | - |
| GTI | - |
| EU | - |
| Scholarships | - |

START OF THE PROJECT

2012

INFORMATION

Xiuhan Chen
015 278 4697
x.chen-1@tudelft.nl

UNSTABLE BREACHING

PROJECT LEADERS

C van Rhee

RESEARCH THEME

Mathematical and computational methods for fluid flow analysis

PARTICIPANTS

D Weij

COOPERATIONS

Deltares

FUNDED

SSB, Rijkswaterstaat

University -

FOM -

STW -

NWO Other -

Industry 100 %

TNO -

GTI -

EU -

Scholarships -

START OF THE PROJECT

2013

INFORMATION

D Weij

015 278 5524

daveweij@tudelft.nl

PROJECT AIM

Breaching is a gradual retreat of a sub-aqueous slope, which is steeper than the angle of repose near the top of the slope. While mainly investigated due to the application of this process in the breaching process, the breaching process can also be a cause for unwanted slope instability and failure. These failures are usually caused by unstable breaching, where the size of the retreating slope increases during the process. The aim of this project is to investigate the unstable breaching process using numerical methods. The main interest in this project is the 3D effects during the process, and the effect of large scale effects.

PROGRESS

During the last year:

- The model was extended to include the pore pressure feedback
- The erosion and sedimentation model was improved
- A small scale experiment was built in the dredging laboratory.

DISSERTATIONS

-

SCIENTIFIC PUBLICATIONS

-

EXCAVATION OF HARD DEPOSITS AND ROCKS (EXHADERO)

PROJECT AIM

The goal of the project is to model the physics of the cutting process of saturated rock-like material, as is the case in dredging, trenching, (oil/gas) drilling, deep sea mining. The interaction of the hydrostatic pressure (water depth) and the pressure of the fluid in the pores of the rock is of essential influence on the failure mechanisms of rock. The model is set up through the combination of the Discrete Element Method for the solid (rock) and a Smoothed Particle Method to describe the effect of the fluid pressure in and surrounding the rock.

PROGRESS

A more thorough validation of the developed method based on DEM and SP has been performed. Qualitative results: Theory of effective stress is still correct with the applied method, under the assumption that the deformation processes are sufficiently slow. Phenomena that occur when the effective stress theory is not valid (pore and hydrostatic pressure are not in equilibrium, like dilatancy strengthening, compactive weakening and stiffening of Young's modulus of the saturated rock) are modeled. The magnitude of these effect correspond with theory and experiments found in literature.

Quantitative results: The applied DEM-SP method shows reasonable resemblances with

- Biot-Gassmann theory for stiffening of rock due to pore fluid
- Experiments based on indentation tests
- (hyperbaric) rock cutting tests for (deep) sea mining applications.

DISSERTATIONS

-

SCIENTIFIC PUBLICATIONS

1. R.L.J. Helmons, S.A. Miedema, C. van Rhee, "A new approach to model hyperbaric rock cutting processes". In ASME 2014 33rd International Conference on Ocean, Offshore and Arctic Engineering.

PROJECT LEADERS

C van Rhee, SA Miedema

RESEARCH THEME

Complex dynamics of fluids

PARTICIPANTS

C van Rhee, SA Miedema,
RLJ Helmons

COOPERATIONS

Industrial consortium, consisting of
Royal Dutch Shell, Royal Boskalis
Westminster NV, Van Oord Dredging
and Marine Contractors BV, Royal
IHC

FUNDED

Agentschap NL (IOP Maritime)
TU Delft, Industrial consortium
University -
FOM -
STW -
NWO Other 80 %
Industry 20 %
TNO -
GTI -
EU -
Scholarships -

START OF THE PROJECT

2012

INFORMATION

RLJ Helmons
015 27 84746
r.l.j.helmons@tudelft.nl

AN EXPERIMENTAL AND NUMERICAL STUDY OF VERTICAL HYDRAULIC TRANSPORT FOR DEEP SEA MINING APPLICATIONS

PROJECT LEADERS

C van Rhee

RESEARCH THEME

Complex dynamics of fluids

PARTICIPANTS

JM van Wijk, AM Talmon

COOPERATIONS

-

FUNDED

IHC Merwede

University -

FOM -

STW -

NWO Other -

Industry 100%

TNO -

GTI -

EU -

Scholarships -

START OF THE PROJECT

2011

INFORMATION

JM van Wijk

06 48 92 96 78

JM.vanWijk@mtiholland.com

jortvanwijk@tudelft.nl

PROJECT AIM

To assess flow assurance of the vertical hydraulic transport process, especially the risk of riser blockage is studied.

PROGRESS

1D 2 phase flow model ready. Navier Stokes for mixture, drift flux for transport of solids. Maximum packing limiter implemented. Wall friction for plug flow implemented.

- pump control implemented in 1D model

- Plug formation by overtaking batches investigated. Journal paper submitted to Ocean Engineering, reviews completed.

- Density waves and stability of the vertical transport process investigated. Concept journal paper written.

- Conductivity Concentration meter calibration for large particles. Journal paper submitted to Flow Measurement and instrumentation

- Dissertation finished except for one chapter (case study using the 1D model).

DISSERTATIONS

-

SCIENTIFIC PUBLICATIONS

1. Wijk, J.M. van, Rhee, C. van and Talmon, A.M. (2014). Wall friction of coarse grained sediment plugs transported in a water flow through a vertical pipe. Ocean Engineering 79 p. 50-57.
2. Wijk, J.M. van, Rhee, C. van and Talmon, A.M. (2014). Axial dispersion of suspended sediments transported in vertical upward pipe flow. Ocean Engineering 92 p. 20-30.

CFD2PHASE

PROJECT AIM

The project aim is to numerical model the hydrodynamical behavior of water/sediment mixtures. This is done using constitutive relations, modeling sediment, and the Navier-Stokes equations. The resulting differential equations are solved using numerical techniques. The sediment fractions are described as a continuum, reducing calculation costs.

PROGRESS

The following actions have been done in 2014

- successfully validated granular soil model with experimental data
- successfully validated concentration and velocity profiles with experimental data
- wrote 1 conference papers and attended the conference
- submitted conference contribution to the Can. Journal of Chemical Engineering
- wrote draft PhD thesis.

DISSERTATIONS

-

SCIENTIFIC PUBLICATIONS

-

PROJECTLEADERS

C van Rhee

RESEARCHTHEME

Mathematical and computational methods for fluid flow analysis

PARTICIPANTS

J Goeree, C van Rhee, A Talmon, G Keetels, project manager: steeringcommittee:

TU Delft: C van Rhee, A Talmon

IHC: E van der Blom, H Bugdayci,

H Van Muijen, EA Munts, H Bugdayci

Utwente: H Hoeijmakers, N Kruijt

COOPERATIONS

TU Delft, Utwente, AgentschapNL, IHC Merwede BV

FUNDED

IHC Merwede BV/AgentschapNL

University -

FOM -

STW -

NWO Other 50 %

Industry 50 %

TNO -

GTI -

EU -

Scholarships -

START OF THE PROJECT

2010

INFORMATION

C van Rhee and J Goeree

j.c.goeree@tudelft.nl

015 278 3297



Prof.dr.ir. C Vuik

The research program of the Numerical Analysis group of TUD belongs to the field of computational science and engineering. We concentrate on the development and application of computing methods to the applied sciences. The focus is on mathematical models relying heavily on partial differential equations, such as occur in fluid dynamics. But we also consider similar mathematical models arising in other fields, for instance materials science and reservoir engineering, usually in cooperation with domain experts. A speciality is problems involving partial differential equations with moving internal boundaries, such as occur in bubbly flows and in phase transition problems. To diminish computing time in large-scale applications, iterative methods for solving large systems of algebraic equations are developed further, using deflation, multi-block, preconditioning and multigrid techniques.

MATHEMATICAL INVESTIGATION INTO SMOOTHNESS-INCREASING ACCURACY-CONSERVING METHODS FOR STREAMLINE VISUALIZATION

PROJECT AIM

The purpose of the proposed research is the mathematical and algorithmic development of smoothness-increasing accuracy-conserving filters with application to post-processing and visualizing discontinuous Galerkin simulation results.

PROGRESS

This past year focused on the theoretical and computational viability of the SIAC filter for geometry that includes nonuniform meshes and filtering for boundaries.

DISSERTATIONS

-

SCIENTIFIC PUBLICATIONS

1. L. Ji and P. van Slingerland and J.K. Ryan and C. Vuik. Superconvergent error estimates for position-dependent smoothness-increasing accuracy-conserving (SIAC) post-processing of discontinuous Galerkin solutions Math. Comp., 83, pp. 2239-2262, 2014.

PROJECT LEADERS

JK Ryan

RESEARCH THEME

Mathematical and computational methods for fluid flow analysis

PARTICIPANTS

X Li

COOPERATIONS

University of Utah, Salt Lake City, UT

FUNDED

European Office of Aerospace Research and Development/U.S. Air Force Office of Research and Development

University 20 %

FOM -

STW -

NWO Other -

Industry -

TNO -

GTI -

EU 80 %

Scholarships -

START OF THE PROJECT

2009

INFORMATION

JK Ryan

015 278 8755

J.K.Ryan@tudelft.nl

<http://ta.twi.tudelft.nl/NW/users/ryan/>

PROJECT LEADERS

C Vuik, A Segal

RESEARCH THEME

Complex dynamics of fluids

PARTICIPANTSC Vuik, A Segal, JM Tang,
R Nabben**COOPERATIONS**TU Eindhoven, Sepra, TNO-Science
and Industry, TU Berlin**FUNDED**

TUD, TNO-TPD, BRICKS

University 25 %

FOM 25 %

STW -

NWO Other -

Industry 25 %

TNO -

GTI 25 %

EU -

Scholarships -

START OF THE PROJECT

1996

INFORMATION

C Vuik

015 278 5530

c.vuik@tudelft.nl

<http://ta.twi.tudelft.nl/users/vuik>**PROJECT AIM**

The purpose is to improve efficiency of solution methods in computational fluid Dynamics, porous media flow and related applications. The DICCG (deflated preconditioned conjugate gradients) method will be developed further. The method will be generalized such that reliable termination criteria can be applied. Domain subdivision methods will be developed to make DICCG applicable.

PROGRESS

The SEPRAN code is parallelized and works efficiently on parallel platforms. More and more users are simulating with the parallel version. This leads to useful feedback in order to enhance the solver. Theoretically the deflation acceleration is compared with an additive coarse grid correction and a balancing Neumann Neumann preconditioner. It appears that the deflation method leads to the fastest convergence, whereas the work per iteration is less or equal to the other methods. Many (in)compressible Navier-Stokes equation solvers use a splitting method to solve the discretized equation. In many applications, especially in bubbly flows, the pressure equation takes most of the time to be solved. One of the reasons is the jump in the density in gas and water. Multi grid methods can be used but some difficulties remain if the size of the bubbles is very small. In this project the pressure equation is solved by the deflated ICCG method. After optimization it appears that the resulting method is 4-5 times faster than the ICCG method. We plan to make a better choice of the projection vectors and try to combine it with domain decomposition and parallel computing.

DISSERTATIONS

-

SCIENTIFIC PUBLICATIONS

1. F.J. Lingen and P.G. Bonnier and R.B.J. Brinkgreve and M.B. van Gijzen and C. Vuik. A parallel linear solver exploiting the physical properties of the underlying mechanical problem Computational Geosciences, 18, pp. 913-926, 2014.

SOLUTION METHODS FOR NAVIER-STOKES PROBLEMS

PROJECT AIM

New preconditioners for the discretized Navier-Stokes equations will be developed. Parallel deflation methods will be included.

PROGRESS

The discrete Navier-Stokes equations are solved by the SIMPLE(R) iteration method. To decrease the very large number of iterations, we have proposed multigrid and Krylov accelerated versions: GCR-SIMPLE(R). The properties of these methods are being investigated for simple two-dimensional flows and three-dimensional flows in industrial glass melting furnaces. These methods are generalised to a colocated discretization and combined with the deflated multiblock approach and parallel computing. Now we try to generalize these solvers to our FEM discretization (SEPRAN) and compare our methods with the recently developed methods given by Elman, Wathen, Sylvester, Benzi, Reusken and Schilders. It appears that MSIMPLER, a new variant of SIMPLER, leads to the fastest results. We also develop a solver based on the Schur complement and multigrid. This method is scalable and leads to very good results for geophysical applications. The GCR-simple solver is also implemented and tested in MARIN software. This lead to a speed-up with a factor 5.

DISSERTATIONS

-

SCIENTIFIC PUBLICATIONS

1. P. van Slingerland and C. Vuik. Fast linear solver for diffusion problems with applications to pressure computation in layered domains. *Computational Geosciences*, 18, pp. 343-356, 2014.
2. M. Lashkarbolok and E. Jabbari and K. Vuik. A node enrichment strategy in colocated discrete least squares meshless method for the solution of generalized Newtonian fluid flow *Scientia Iranica A*, 20, pp. 1-10, 2014.

PROJECTLEADERS

C Vuik

RESEARCHTHEME

Complex dynamics of fluids

PARTICIPANTS

C Vuik, S MacIaclan, Geenen, A Segal, P van Slingerland

COOPERATIONS

TNO-Science and Industry
Utrecht University, Sepra Tufts
University USA, MARIN

FUNDED

| | |
|--|------|
| STW, TUD, TNO-Science and Industry, Nuffic-HEC, MARIN University | 25 % |
| FOM | - |
| STW | - |
| NWO Other | - |
| Industry | 75 % |
| TNO | - |
| GTI | - |
| EU | - |
| Scholarships | - |

START OF THE PROJECT

1992

INFORMATION

C Vuik
015 278 5530
c.vuik@tudelft.nl
<http://ta.twi.tudelft.nl/users/vuik>

PROJECT LEADERS

C Vuik, FJ Vermolen

RESEARCH THEME

Complex dynamics of fluids

PARTICIPANTS

D Ibrahim, FJ Vermolen, C Vuik,
WK van Wijngaarden-van Rossum

COOPERATIONS

-

FUNDED

| | |
|--------------|------|
| Deltares | |
| University | 25 % |
| FOM | - |
| STW | - |
| NWO Other | - |
| Industry | 75 % |
| TNO | - |
| GTI | - |
| EU | - |
| Scholarships | - |

START OF THE PROJECT

2007

INFORMATION

FJ Vermolen
015 278 7298
F.J.Vermolen@tudelft.nl

PROJECT AIM

Develop numerical methods for industrial flow problems.

PROGRESS

A numerical method to cope with pressure boundary conditions on a extraction well has been constructed and analysed. The method is based on a finite-element discretization over the well where the integral boundary condition is evaluated as a boundary value problem. Oscillations are suppressed by the use of SUPG-techniques. Furthermore, a theorem has been formulated and proved about the shift of the spectrum of eigenvalues to the finite-element operator resulting from a standard and SUPG discretization of the boundary value problem. Besides this result, a model for the placement of bacteria has been coupled to the actual fortification model for soils. Next to this work, an experimental validation for the two-dimensional case of the model has been performed and a paper has been submitted about this issue to Transport in Porous Media.

DISSERTATIONS

-

SCIENTIFIC PUBLICATIONS

1. W.K. van Wijngaarden and F.J. Vermolen and G.A.M. van Meurs and C. Vuik
A robust method to tackle pressure boundary conditions in porous media flow: application to biogROUT, Computational Geosciences, 18, pp. 103-115, 2014.

TWO-PHASE RESPIRATORY FLOW

PROJECT AIM

The purpose of the project is to extend the Mass Conserving Level Set method to complex domains, by a reformulation for unstructured discretisation of the flow equations, specifically to be able to model two-phase flow in the human respiratory system.

PROGRESS

The extension of the MCLS is formulated to have mass conservation up to machine precision for convection with both linear and nonlinear velocity fields. The method is more efficient than the original formulation because the conversion from level-set field to volume-of-fluid is a completely local procedure and does not require the inversion of a nonlinear system of equations. However, the advection procedure that utilizes geometric 'clipping' algorithms is relatively costly to apply. An alternative, more efficient formulation based on the modified level-set field is currently investigated.

DISSERTATIONS

-

SCIENTIFIC PUBLICATIONS

-

PROJECT LEADERS

DR van der Heul

RESEARCH THEME

Mathematical and computational methods for fluid flow analysis

PARTICIPANTS

F Raees

COOPERATIONS

-

FUNDED

| | |
|--------------|-------|
| University | - |
| FOM | - |
| STW | - |
| NWO Other | - |
| Industry | - |
| TNO | - |
| GTI | - |
| EU | - |
| Scholarships | 100 % |

START OF THE PROJECT

2011

INFORMATION

DR van der Heul

015 278 2632

D.R.vanderHeul@tudelft.nl

PROJECT LEADERS

C Vuik, CW Oosterlee

RESEARCH THEME

Complex dynamics of fluids

PARTICIPANTS

C Oosterlee, C Vuik, D Lahaye,
A Sheikh

COOPERATIONS

TUD Chem.Tech, Philips, Shell,
NLR, TU Berlin

FUNDED

| | |
|--------------------------|------|
| SenterNovem, NLR, Nuffic | |
| University | 25 % |
| FOM | - |
| STW | - |
| NWO Other | - |
| Industry | 75 % |
| TNO | - |
| GTI | - |
| EU | - |
| Scholarships | - |

START OF THE PROJECT

2001

INFORMATION

C Vuik
015 278 5530
C.Vuik@tudelft.nl
<http://ta.twi.tudelft.nl/users/vuik>

PROJECT AIM

The aim is to develop efficient parallel iterative solvers for the Helmholtz problem. In order to estimate the layered structure of the earth crust seismic methods are used. The layer structure is used as input for porous media flow simulations.

PROGRESS

A special preconditioner has been developed, which in a special combination of Krylov subspace and multigrid methods has resulted in a hundredfold increase in computing speed for the Helmholtz equation, describing wave propagation. Application in seismics has been very successful, and has generated much interest from the oil exploration industry, especially after a comparison with an industrial code in an application to a practical problem posed by industry. For the first time, realistic three-dimensional applications become feasible. This has already been realized on a single-processor machine for medium-sized problems. The 3D code for the seismic simulation package has been parallelized. Furthermore, a comparison with analytic solutions will be made. The fast solver technique will be generalized to a finite element discretization of the Maxwell equations, for radar simulations.

DISSERTATIONS

1. Sheikh, AH (2014, november 18). Development of the Helholtz Solver based on a shifted laplace preconditioner and a multigrid deflation technique. TUD Technische Universiteit Delft (123 pag.). Prom./coprom.: Prof.dr.ir. C Vuik.

SCIENTIFIC PUBLICATIONS

1. H. Knibbe and W.A. Mulder and C. W. Oosterlee and C. Vuik. Closing the performance gap between an iterative frequency-domain solver and an explicit time-domain scheme for 3D migration on parallel architectures. Geophysics, 79, pp. S47-S61, 2014.

NUMERICAL METHODS FOR PHASE TRANSFORMATIONS IN METALS AND ALLOYS

PROJECT AIM

Develop numerical methods for moving boundary problems and evolution of the statistical size distribution of particles.

PROGRESS

A cellular automata method has been developed for the modeling of recrystallization in steel alloys. This work has been done in collaboration with TATA-steel.

DISSERTATIONS

-

SCIENTIFIC PUBLICATIONS

-

PROJECT LEADERS

FJ Vermolen

RESEARCH THEME

Complex dynamics of fluids

PARTICIPANTS

D den Ouden, FJ Vermolen, C Vuijk,
L Zhao, J Sietsma

COOPERATIONS

-

FUNDED

M2i (Materials, Metals Innovation)

University -

FOM -

STW -

NWO Other -

Industry 100 %

TNO -

GTI -

EU -

Scholarships -

START OF THE PROJECT

-

INFORMATION

FJ Vermolen

015 278 7298

F.J.Vermolen@tudelft.nl

<http://ta.twi.tudelft.nl/users/vermolen>

PROJECT LEADERS

FJ Vermolen

RESEARCH THEME

Complex dynamics of fluids

PARTICIPANTS

S Zemskov, FJ Vermolen

COOPERATIONS

-

FUNDED

DCMat (Delft Centre of Materials)

University -

FOM -

STW -

NWO Other -

Industry 100 %

TNO -

GTI -

EU -

Scholarships -

START OF THE PROJECT

-

INFORMATION

FJ Vermolen

015 278 7298

F.J.Vermolen@tudelft.nl

<http://ta.twi.tudelft.nl/users/vermolen>

PROJECT AIM

Develop models and methods for the simulation of self-healing of materials.

PROGRESS

An analytic model for self-healing materials has been developed. The model takes into account the dissolution of particles containing a self-healing agent that diffuses towards the damaged surface of the material.

DISSERTATIONS

-

SCIENTIFIC PUBLICATIONS

-

MATHEMATICAL HEALTH

PROJECT AIM

Develop numerical methods for several problems related to health issues.

PROGRESS

A model for angiogenesis is being constructed in the MSc-work of Frans Bookholt. The model is based on the cell-based formalism that has been developed by Vermolen & Gefen. The first results look promising. Further, various mathematical models for the simulation of scars and contractures in burns are being developed by PhD-student Daniel Koppenol. A paper about a phenomenological model for contractions in burns has been developed by Vermolen. All the modelling work is either based on solving (or approximating solutions to) partial differential equations or on semi-stochastic principles.

DISSERTATIONS

-

SCIENTIFIC PUBLICATIONS

1. P.A. Prokharau, F.J. Vermolen, J.M. Garcia-Aznar, A mathematical model for cell differentiation, as an evolutionary and regulated process, *Computer Methods in Biomechanics and Biomedical Engineering*, 17(10), pp. 1051-1570 (2014).
2. F.J. Vermolen, A. Gefen, Semi-stochastic cell-level computational modelling of the immune system response to bacterial infections and the effects of antibiotics, *Biomechanical Modeling and Mechanobiology*, 13(4), pp. 713-734 (2014).

PROJECTLEADERS

FJ Vermolen

RESEARCHTHEME

Complex dynamics of fluids

PARTICIPANTS

PA Prokharau, D Koppenol,
A Gefen, FJ Vermolen

COOPERATIONS

-

FUNDED

Dutch Burns Foundation
University -
FOM -
STW -
NWO Other -
Industry 100 %
TNO -
GTI -
EU -
Scholarships -

START OF THE PROJECT

-

INFORMATION

FJ Vermolen

015 278 7298

F.J.Vermolen@tudelft.nl

<http://ta.twi.tudelft.nl/users/vermolen>

STATE-OF-THE-ART MODELING OF MULTIPHASE FLOW IN LARGE PIPELINE SYSTEMS

PROJECT LEADERS

C Vuik, DR van der Heul

RESEARCH THEME

Mathematical and computational methods for fluid flow analysis

PARTICIPANTS

J van Zwieten

COOPERATIONS

Shell

FUNDED

Shell

University -

FOM -

STW -

NWO Other -

Industry 100 %

TNO -

GTI -

EU -

Scholarships -

START OF THE PROJECT

2011

INFORMATION

DR van der Heul

015 278 2632

D.R.vanderHeul@tudelft.nl

PROJECT AIM

The purpose of the project is to develop a robust, efficient and accurate algorithm for the simulation of multiphase flow in large (Length >> diameter) pipeline systems.

PROGRESS

A Space-Time Discontinuous Galerkin Finite Element discretisation for one-dimensional

multiphase flow models has been developed. The discretisation supports adaptive, local h- and p-refinement in both space and time, which can yield a significant reduction of the number of degrees of freedom required to represent a discrete solution and of the amount of work required to compute the discrete solution, compared to uniform refinement. Spurious oscillations are reduced by locally adding artificial viscosity.

DISSERTATIONS

-

SCIENTIFIC PUBLICATIONS

1. J. S. B. van Zwieten. Towards advanced one-dimensional numerical models for multiphase flow in pipelines. Technical Report 13-06, Delft Institute of Applied Mathematics, 2013.
2. J. S. B. van Zwieten, D. R. van der Heul, R. H. A. IJzermans, R. A. W. M. Henkes, and C. Vuik. Two-phase flow solved by high order discontinuous Galerkin method. In M. Azañez, H. El Fekih, and J. S. Hesthaven, editors, Spectral and High Order Methods for Partial Differential Equations - ICOSAHOM 2012, volume 95 of Lecture Notes in Computational Science and Engineering, pages 415-425. Springer International Publishing, 2014. ISBN 978-3-319-01600-9. doi: 10.1007/978-3-319-01601-6_34.
3. J. S. B. van Zwieten, R. A. W. M. Henkes, D. R. van der Heul, P. I. Rosen Esquivel, B. Sanderse, and C. Vuik. Two-phase flow solved by high order discontinuous Galerkin method. In S. T. Johansen and J. E. Olsen, editors, Proceedings of the 10th International Conference on Computational Fluid Dynamics in the Oil & Gas, Metallurgical and Process Industries, Trondheim, Norway, 2014. ISBN 978-82-14-05741-6.

PROJECT AIM

The purpose of the project is to obtain a better understanding of the transition from stable to unstable multiphase flow in pipeline systems through numerical simulations.

PROGRESS

In the last year, an axisymmetric version of the MCLS algorithm was developed and rigorously tested. This seemed a logical step, as many multiphase benchmark test cases are in fact axisymmetric, and therefore computational effort in the verification phase of the development is greatly reduced. Furthermore, the lessons learned from optimizing the axisymmetric algorithm will be directly applied to the full cylindrical algorithm. A variety of test cases has shown that the axisymmetric algorithm is robust and accurate.

DISSERTATIONS

-

SCIENTIFIC PUBLICATIONS

1. Denner F, van der Heul DR, Oud GT, Villar MM, Neto ADS, van Wachem BGM et al., 2014, Comparative study of mass-conserving interface capturing frameworks for two-phase flows with surface tension, INTERNATIONAL JOURNAL OF MULTIPHASE FLOW, Vol: 61, Pages: 37-47, ISSN: 0301-9322. DIAM report: Development and validation of the cylindrical Mass Conserving Level Set method, 14-3, ISSN 1389-6520.

PROJECT LEADERS

DR van der Heul

RESEARCH THEME

Mathematical and computational methods for fluid flow analysis

PARTICIPANTS

G Oud

COOPERATIONS

-

FUNDED

| | |
|----------------------|------|
| SHELL, DELTARES, TNO | |
| University | - |
| FOM | - |
| STW | - |
| NWO Other | - |
| Industry | 33 % |
| TNO | 33 % |
| GTI | 33 % |
| EU | - |
| Scholarships | - |

START OF THE PROJECT

2011

INFORMATION

DR van der Heul

015 278 2632

D.R.vanderHeul@tudelft.nl

PROJECT LEADERS

S Turek, M Möller

RESEARCH THEME

Mathematical and computational methods for fluid flow analysis

PARTICIPANTS

BS Hosseini, M Möller

COOPERATIONS

-

FUNDED

University -

FOM -

STW -

NWO Other -

Industry -

TNO -

GTI -

EU -

Scholarships -

START OF THE PROJECT

2011

INFORMATION

M Möller

015 278 9755

M.Moller@tudelft.nl

[http://ta.twi.tudelft.nl/nw/users/](http://ta.twi.tudelft.nl/nw/users/matthias)

matthias

PROJECT AIM

Develop an efficient isogeometric analysis framework for the simulation of multi-physics problems. Concrete problems to be considered are fluid-structure interaction in blood flow problems.

PROGRESS

The PhD-candidate finished a prototypical implementation of a single phase incompressible flow solver based on the isogeometric analysis approach (NURBS-based) and validated it against standard benchmarks for the Navier-Stokes equations. Recent research activities focus on improving the efficiency of the multigrid solver and on extending the code towards fluid-structure interaction problems.

DISSERTATIONS

-

SCIENTIFIC PUBLICATIONS

-

NUMERICAL SIMULATION OF SURFACE-PIERCING PROPELLERS BY SPH/FEM METHODS

PROJECT AIM

Develop hybrid SPH-FEM method for the efficient simulation of free surface flows. The aim is to use the SPH method to effectively model the free surface flow and combine it with the FEM in regions with single phase flow so as to reduce the computational costs of a pure SPH method.

PROGRESS

The PhD-candidate Xu started working on this topic in October 2014. He has a background in SPH methods but is not familiar with FEM yet. The existing SPH code is being validated for standard benchmark problems such as Pousseuille and Couette flow and compared to reference results for FEM. The PhD-candidate implemented a prototypical Poisson solver to get familiar with FEM, which will be used as building block to solve the pressure Poisson problem in the Navier-Stokes equations.

DISSERTATIONS

-

SCIENTIFIC PUBLICATIONS

-

PROJECTLEADERS

C Vuiik, M Möller

RESEARCHTHEME

Mathematical and computational methods for fluid flow analysis

PARTICIPANTS

F Xu, C Vuiik, M Möller

COOPERATIONS

-

FUNDED

| | |
|---------------------------|-------|
| China Scholarship Council | |
| University | - |
| FOM | - |
| STW | - |
| NWO Other | - |
| Industry | - |
| TNO | - |
| GTI | - |
| EU | - |
| Scholarships | 100 % |

START OF THE PROJECT

2014

INFORMATION

M Möller

015 278 9755

M.Moller@tudelft.nl

[http://ta.twi.tudelft.nl/nw/users/](http://ta.twi.tudelft.nl/nw/users/matthias)

matthias

PROJECT LEADERS

DJP Lahaye

RESEARCH THEME

Mathematical and computational methods for fluid flow analysis

PARTICIPANTS

A Kadar

COOPERATIONS

-

FUNDED

Almatis BV

University -

FOM -

STW -

NWO Other -

Industry 100 %

TNO -

GTI -

EU -

Scholarships -

START OF THE PROJECT

2010

INFORMATION

D Lahaye

015 27 87 257

d.j.p.lahaye@tudelft.nl

ta.twi.tudelft.nl/nw/users/domenico/

PROJECT AIM

The aim of the project is to develop and deploy mathematical modeling and numerical simulation tools to increase the productivity of a rotary kiln. We consider a kiln used in the production of high-end calcium-alumina cement. In a first stage we built a 3D turbulent combustion model for the temperature and radiative heat transfer in the kiln. In a second stage we developed a system of coupled ODEs for the heat absorption and sintering reactions for the materials being processed.

PROGRESS

In recent work we are investigating the possibility to replace commercial available simulation package by the public domain OpenFoam. Our goal is to implement a 3D non-premixed turbulent combustion model including radiation and conjugate heat transfer to model the insulating lining in OpenFoam.

DISSERTATIONS

-

SCIENTIFIC PUBLICATIONS

-



Prof.dr.ir. AW Heemink

The central research direction of the group is the mathematical modeling of physical phenomena using (partial) differential equations. The research is application driven and includes the modeling phase, analysis of the model and the numerical implementation of the model. The focus is now more and more on the research themes:

INVERSE MODELING AND DATA ASSIMILATION

Data assimilation methods are used to combine the results of a large scale numerical model with the measurement information available in order to obtain an optimal reconstruction of the dynamic behavior of the model state. Many data assimilation schemes are based on solving the Euler-Lagrange equations. A recursive algorithm to solve this two-point boundary value problem can be derived and results in the well-known Kalman filtering algorithm. Variational data assimilation is also a powerful method, but requires the implementation of the adjoint (of the tangent linear approximation) of the numerical model. In a series of externally funded PhD projects the mathematical algorithms have been developed and applied in a number of real life applications:

- Tidal flow models (funding: Rijkswaterstaat)
- Atmospheric-chemistry modeling (funding: NWO, TNO, RIVM).
- Oil reservoir modeling (Funding: Shell, TNO).

PERTURBATION METHODS FOR PARTIAL DIFFERENTIAL EQUATIONS

The main focus within this theme is to develop perturbation methods to analyse initial value problems and initial-boundary value problems for partial differential equations. The applications are in a variety of fields, such as: the wind flow (or rain-wind) induced oscillations of bridges, high-rise buildings, or of overhead power transmission lines; the vibrations of conveyor belts; and the morphodynamics in tidal embayments.

HIGH PERFORMANCE COMPUTING AND PARALLEL ALGORITHMS

This research theme aims to design efficient and scalable parallel algorithms and apply high performance computing technology to applications, such as the storm surge forecasting and pollutant transport in North Sea or rivers. Domain decomposition and grid partitioning is an effective approach for parallel simulation of models described by partial differential equations. Sparse matrices typically occur in numerical simulation of problems described by partial differential equations. One of our research focus is on designing parallel algorithms for solving sparse matrix systems. Lagrangian models, often also called particle models, for transport problems in coastal waters, can deal with steep gradients of concentration. Because the movements of the particles are largely independent from each other, so particle models are very suited for parallel and distributed computing. We have developed parallel models for transport problems of the Dutch coastal water (e.g., Wadden sea). Currently, a particle model with adaptive time steps is being developed, besides the derivation of the numerical scheme the additional challenge is to maintain a good load balance in an adaptive scheme. Grid computing is the next step of development in high performance computing.

PARALLEL ALGORITHMS AND GRID COMPUTING

PROJECT AIM

The research aims at the design and implementation of high performance and parallel algorithms for data assimilation methods. The applicability and limitations of the distributed and grid computing technology will also be investigated.

PROGRESS

The research focuses on designing parallel algorithms for large scale sparse matrix computations and for applications using data assimilation techniques such as ensemble Kalman filters (EnKF) and 4D-Var methods. Multi-level parallel EnKF algorithms are currently being developed, the methods are applied to volcano ash distribution modelling with aircraft and satellite measurement data . Parallelization using large heterogeneous clusters and GPUs (General-purpose graphical units) has been investigated in the implementation of multi-level parallel EnKF algorithms.

DISSERTATIONS

-

SCIENTIFIC PUBLICATIONS

-

PROJECT LEADERS

AW Heemink, HX Lin

RESEARCH THEME

Mathematical and computational methods for fluid flow analysis

PARTICIPANTS

HX Lin, GL Fu, SM Xu

COOPERATIONS

Reykjavik University, Iceland

FUNDED

| | |
|--------------|------|
| University | 50 % |
| FOM | - |
| STW | - |
| NWO Other | - |
| Industry | - |
| TNO | - |
| GTI | - |
| EU | - |
| Scholarships | 50 % |

START OF THE PROJECT

2012

INFORMATION

HX Lin

015 278 7229

H.X.Lin@tudelft.nl

<http://mathematicalphysics.ewi.tudelft.nl>

tudelft.nl

PROJECT LEADERS

AW Heemink

RESEARCH THEME

Mathematical and computational methods for fluid flow analysis

PARTICIPANTS

MDLC Rojas Larrazabal,
RG Hanea, MU Altaf, C van Velzen,
M Verlaan, AW Heemink, IDTF
Garcia, CM Maris, SP Szklarz

COOPERATIONS

Deltares, RIVM, Shell, MIT,
TNO, Vortech

FUNDED

| | |
|---------------------------|------|
| Deltares, Shell, TNO, NWO | |
| University | 10 % |
| FOM | - |
| STW | - |
| NWO Other | 10 % |
| Industry | 20 % |
| TNO | 30 % |
| GTI | 20 % |
| EU | - |
| Scholarships | 10 % |

START OF THE PROJECT

2001

INFORMATION

AW Heemink
015 278 5813
a.w.heemink@tudelft.nl

PROJECT AIM

Large scale numerical models are often used for prediction problems. These models however are however far from perfect. The model predictions can be improved by assimilating measurements into the model using a Kalman filter. A serious problem with this approach is that the standard filter algorithm imposes a very large burden on the computer. In order to obtain a computationally efficient filter, simplifications have to be introduced. Model reduction is a corner stone in developing sub-optimal scheme's. In this project new sub optimal algorithms to solve large scale Kalman filtering problems are developed.

PROGRESS

We have developed a model reduction methodology for large scale numerical models in corporation with TNO, Shell and Deltares. New PhD projects around the theme "Smart Wells" in corporation with the faculty CiTG, MIT and Shell have started. In these PhD projects we will develop and apply model reduction and filtering techniques for assimilating data into multi-phase flow models in order to solve reservoir engineering problems. New application areas are also ecological coastal sea models and morphodynamic models.

DISSERTATIONS

1. Towards a data assimilation system for morphodynamic modeling, PhD thesis Delft University of Technology, I.D.T.F. Garcia Triana, 12 May 2014, promotoren: A.W. Heemink and H.M. Schuttelaars.
2. Data assimilation under geological constraints, M.B. Sebacher, PhD thesis Delft University of Technology, 18 December 2014, promotor: A.W. Heemink.

SCIENTIFIC PUBLICATIONS

1. Data assimilation framework: Linking an open data assimilation library (OpenDA) to a widely adopted model interface (OpenMI) Ridler, Marc E.; van Velzen, Nils; Hummel, Stef; et al. ENVIRONMENTAL MODELLING & SOFTWARE Volume: 57 Pages: 76-89 Published: JUL 2014.
2. A Comparison of Ensemble Kalman Filters for Storm Surge Assimilation Altaf, M. U.; Butler, T.; Mayo, T.; et al. MONTHLY WEATHER REVIEW Volume: 142 Issue: 8 Pages: 2899-2914 Published: AUG 2014.

PERTURBATION METHODS FOR PARTIAL DIFFERENTIAL EQUATIONS

PROJECT AIM

The main focus within this project is to develop and to apply perturbation methods to analyze initial value problems and (initial) boundary value problems for partial differential equations. The applications are in a variety of fields, such as: the wind or rain-wind induced oscillations of elastic structures (such as bridges, high-rise buildings, and overhead power transmission lines); the vibrations of conveyor belts and elevator cables; the morphodynamic evolution of coastal systems (such as beaches, and estuaries); and the dynamics of polymers in shear flow.

PROGRESS

In 2014 the applicability of different types of perturbation methods was investigated. For problems with boundary damping, for nonselfadjoint problems, for weakly nonlinear problems, and for problems with variable coefficients all kinds of computational aspects have been studied by using perturbation methods, methods from dynamical system theory, numerical methods, and stochastic methods.

DISSERTATIONS

-

SCIENTIFIC PUBLICATIONS

1. Seasonal variability in M2 and M4 tidal constituents and its implications for the coastal residual sediment transport. U. Gräwe, H. Burchard, M. Müller, H.M. Schuttelaars. (2014) *Geophysical Research Letters*, 41 (15) pp. 5563-5570.
2. The influence of channel deepening on estuarine turbidity levels and dynamics, as exemplified by the Ems estuary. V.N. de Jonge, H.M. Schuttelaars, J.E.E. van Beusekom, S.A. Talke, H.E. de Swart. (2014) *Estuarine, Coastal and Shelf Science*, 139, pp. 46-59.
3. Numerical bifurcation methods and their application to fluid dynamics: Analysis beyond simulation. H.A. Dijkstra, F.W. Wubs, A.K. Cliffe, E. Doedel, I.F. Dragomirescu, B. Eckhardt, A.Y. Gelfgat, A.L. Hazel, V. Lucarini, A.G. Salinger, E.T. Phipps, S. -U. Juan, H.M. Schuttelaars, L.S. Tuckerman, U. Thiele. (2014) *Communications in Computational Physics*, 15 (1), pp. 1-45.
4. On oscillations of a beam with a small rigidity and time-varying mass. A.K. Abramian, W.T. van Horssen, S.A. Vakulenko (2014). *Nonlinear Dynamics*, 78(1), 449-459.
5. On constructing solutions for the functional equation $Z(x,y,n)=Z(a(11)x+a(12)y,a(21)x+a(22)y,n+1)$. M. Rafei, W.T. van Horssen (2014). *Applied Mathematics and Computation*, 237, 373-385.
6. On variable length induced vibrations of a vertical string. S. Sandilo, H. Sajad, W.T. van Horssen. (2014). *Journal of Sound and Vibration*, 333(11), 2432-2449.
7. Force spectroscopy of polymer desorption: theory and molecular dynamics simulations. J. Paturej, J.L.A. Dubbeldam, V.G. Rostiashvili, A. Milchev, T.A. Vilgis. *Soft Matter* 10, 2785-2799 (2014).
8. Bifurcation analysis of a model for atherosclerotic plaque evolution. M.A.K. Bulelzi, J.L.A. Dubbeldam, H.G.E. Meijer. *Physica, D* 278-279, 31-43 (2014).
9. Driven translocation of a polymer: Role of pore friction and crowding. J.L.A. Dubbeldam, V.G. Rostiashvili, T.A. Vilgis. *J. Chem. Phys.* 141, 124112 (2014); <http://dx.doi.org/10.1063/1.4896153>.

PROJECT LEADERS

AW Heemink

RESEARCH THEME

Mathematical and computational methods for fluid flow analysis

PARTICIPANTS

WT van Horssen, HM Schuttelaars, JLA Dubbeldam, T Akkaya, N Gaiko, R Ali, M Kumar, X Wei, K Xi

COOPERATIONS

-

FUNDED

| | |
|--------------|------|
| University | 60 % |
| FOM | - |
| STW | - |
| NWO Other | 10 % |
| Industry | 10 % |
| TNO | - |
| GTI | - |
| EU | - |
| Scholarships | 20 % |

START OF THE PROJECT

2003

INFORMATION

WT van Horssen

015 278 3524

W.T.vanHorssen@tudelft.nl

<http://math.ewi.tudelft.nl>

TRANSPORT PHENOMENA



Prof.dr.ir. CR Kleijn



Prof.dr. RF Mudde



Prof.dr.ir. HEA van den Akker



Prof.dr.S Sundaresan



Prof.dr.ir. JJ Derksen

The Transport Phenomena group studies the transport of mass, momentum and heat, on different length and time scales, in physical, biological and chemical processes related to advanced materials processing, energy conversion and storage, and health. The main interest is in transport phenomena around (solid-fluid, liquid-gas and liquid-liquid) interfaces, which we wish to understand, control and enhance.

The group uses both theoretical and computational models, and non-intrusive experiments based on laser and X-ray techniques.

Our expertise is in heat and mass transfer in multiphase flows, turbulent flows, microflows and biological flows.

A partial list of topics which we currently work on:

- Multiphase flow and dynamic contact line phenomena in digital microfluidics and Labs-on-Chips
- Dispersed multiphase flows in large scale chemical processing (bubble columns, fluidized beds, Fischer Tropsch)
- Magneto-hydrodynamics in advanced liquid metal processing (welding, casting)
- Magnetic drug targeting
- Oil-water separation
- Turbulence modulation for enhanced heat and mass transfer

MODELLING OF INTERFACE EVOLUTION IN ADVANCED WELDING (MINTWELD)

PROJECT AIM

The MINTWELD project aims to improve welding processes by using simulation models working on a range of length scales and knowledge gained from industrial experiments. Our contribution is to develop computational models for the prediction of the influence of hydrodynamics on the interface evolution in advanced welding processes.

PROGRESS

We have completed a software tool to predict laser welding processes, which requires the simulation of the transient flow of molten steel driven by thermocapillary forces as well as the heat distribution in the base metal and the final weld pool shape, both of which are highly dependent on the flow within the pool. We can also simulate arc welding processes, which additionally require the computation of the current distribution in the weld, the resulting Lorentz forces, and the inclusion of the shear exerted by the arc on the liquid pool.

The code has been extensively validated against test cases from literature as well as experimental welding trials conducted at TUD-3ME. Results obtained so far demonstrate the strong influence of surfactants on the welding process and confirm the importance of surface tension differences as a main driving force. Furthermore, we have coupled our macroscale model to a mesoscale solidification model developed by our partners at University College Dublin. The combined model can predict microstructural changes during the solidification of a welded section, which have a big impact on the mechanical properties of the weld.

DISSERTATIONS

-

SCIENTIFIC PUBLICATIONS

-

PROJECT LEADERS

CR Kleijn, S Kenjeres

RESEARCH THEME

Complex dynamics of fluids

PARTICIPANTS

A Kidess, CR Kleijn, S Kenjeres

COOPERATIONS

Prof. Ian Richardson, Dr. Chuangxin Zhao (both TU Delft Materials Science and Engineering) University of Leicester; University College Dublin; University of Oxford; Norwegian Institute of Science and Technology; Royal Institute of Technology Stockholm; Ecole Polytechnique Federale de Lausanne; Tata Steel UK; TWI; Frenzak; Polish Welding Centre of Excellence

FUNDED

| | |
|--------------|-------|
| EU FP7 | - |
| University | - |
| FOM | - |
| STW | - |
| NWO Other | - |
| Industry | - |
| TNO | - |
| GTI | - |
| EU | 100 % |
| Scholarships | - |

START OF THE PROJECT

2009

INFORMATION

CR Kleijn
015 278 2835
C.R.Kleijn@TUDelft.NL
www.cheme.nl/tp

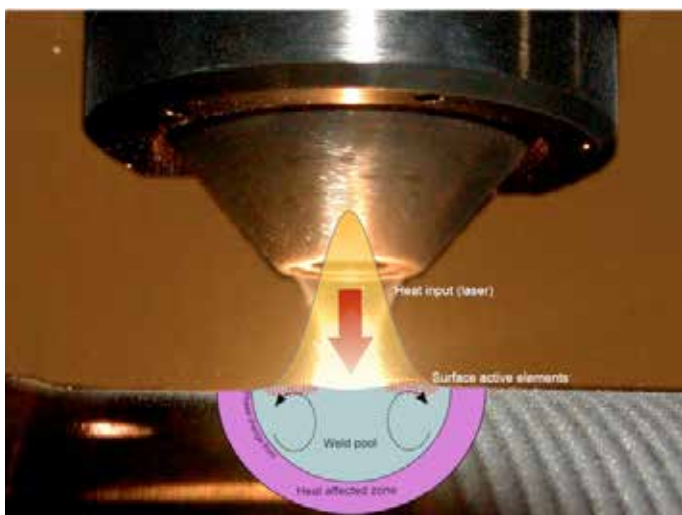

NUMERICAL FLOW SIMULATIONS ON IMPROVED CONTINUOUS CASTING THROUGH ELECTROMAGNETIC FLOW CONTROL

PROJECT LEADERS

CR Kleijn, S Kenjereš, M Tummers

RESEARCH THEME

Complex dynamics of fluids

PARTICIPANTS

B Righolt

COOPERATIONS

Tata Steel, ABB

FUNDED

STW, Tata Steel, ABB

University -

FOM -

STW 88 %

NWO Other -

Industry 12 %

TNO -

GTI -

EU -

Scholarships -

START OF THE PROJECT

2010

INFORMATION

BW Righolt

015 278 7084

b.w.righolt@tudelft.nl

PROJECT AIM

The aim of the project is to provide a fundamental understanding of, and experimentally validated models for, the influence of electromagnetic fields on flow, turbulence and heat transfer in liquid steel during continuous casting. These insights and models will make it possible to design and to optimize new strategies for controlling steel casting processes, leading to significant energy savings, increased productivity and improved product quality.

PROGRESS

We developed a zero-dimensional model that describes the self-sustained oscillation of a confined jet in a thin cavity. Different terms in this model represent the different stages of the oscillation, namely the pressure driven growth of the oscillation, the bounding of the oscillation by the geometry, and the delayed destruction of the recirculation zone. The model parameters depend on the inlet velocity, the Reynolds number, the cavity width and the cavity width to nozzle diameter ratio. The model was successfully validated against LES simulation and PIV measurements, and predict the existence and frequency of the self-sustained oscillation. The model helps creating a better understanding and new insights on the self-sustained oscillations.

DISSERTATIONS

-

SCIENTIFIC PUBLICATIONS

1. Rudi Kalter, Mark J Tummers, Sasa Kenjeres and Chris R Kleijn (2014) Electromagnetic flow control of a bifurcated jet in a rectangular cavity. *International Journal of Heat and Fluid Flow* 47 (2014) 113–122.
2. Rudi Kalter, Mark J. Tummers, Sasa Kenjeres, Bernhard W. Righolt, and Chris R. Kleijn (2014). Effects of electromagnetic forcing on self-sustained jet oscillations. *PHYSICS OF FLUIDS* 26, 065101 (2014).
3. Rudi Kalter, Mark J. Tummers, Jeroen Wefers Bettink, Bernhard W. Righolt, Sasa Kenjeres, Chris R. Kleijn. Aspect ratio effects on fluid flow fluctuations in rectangular cavities. *Metallurgical and Materials Transactions B*, 45B (2014), pp. 2186-2193.
4. R. Kalter, B. W. Righolt, S. Kenjeres, M. J. Tummers and C. R. Kleijn. EXPERIMENTAL MODELING OF HEAT TRANSFER IN A CONTINUOUS CASTING MOULD MODEL. *Proceedings of The ASME 2014 4th Joint US-European Fluids Engineering Summer Meeting & 12th International Conference on Nanochannels, Microchannels, and Minichannels FEDSM2014* paper #FEDSM2014-21179, 8 pages.

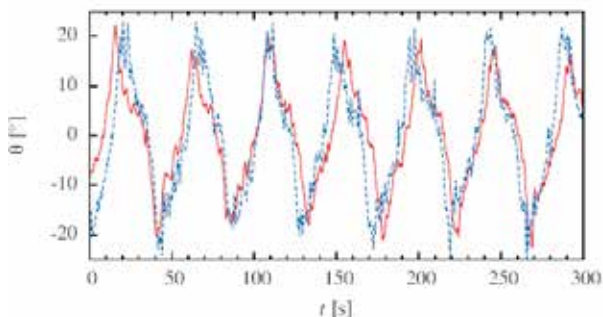

Jet angle as a function of time. PIV measurements (blue dashed) and LES simulations (red line)

PROJECT AIM

The goal of this project is to develop predictive models for the protective behavior and thermal comfort of Nuclear-Biological-Chemical protective textiles, with a special focus on chemical breakthrough. We study air flow, heat and mass transfer through the textile at multiple scales, ranging from that of the textile fibers and carbon particles to that of an entire person, in combination with the penetration of both gaseous and liquid toxic components.

PROGRESS

We developed a computational model for flow, heat and mass transfer to a solid cylinder, mimicking a limb, sheathed by CBRN protective garment material, and exposed to a turbulent cross flow of air with a tracer amount of hazardous gas. The computational model has been successfully validated against published experimental data. The model shows that, for realistic conditions, the introduction of a single layer of carbon material with an open area fraction as large as 0.6 reduces the mass deposition of tracer gas onto the cylinder by one to three orders of magnitude, whereas heat transfer is decreased by tens of percents, thus optimizing the balance between protection and thermal comfort.

DISSERTATIONS

-

SCIENTIFIC PUBLICATIONS

1. D. Ambesi, E.A. den Hartog, R.H.B. Bouma, P. Brassler, C.R. Kleijn (2014) Forced convection mass deposition and heat transfer onto a cylinder sheathed by protective garments. *AIChE Journal* 60(1), 2014, pp. 353-361

PROJECT LEADERS

CR Kleijn

RESEARCH THEME

Complex dynamics of fluids

PARTICIPANTS

D Ambesis, CR Kleijn

COOPERATIONS

TNO Defense and Security

FUNDED

| | |
|--------------|-------|
| TNO | |
| University | - |
| FOM | - |
| STW | - |
| NWO Other | - |
| Industry | - |
| TNO | 100 % |
| GTI | - |
| EU | - |
| Scholarships | - |

START OF THE PROJECT

2009

INFORMATION

CR Kleijn
 015 278 2835
 C.R.Kleijn@TUDelft.NL
 www.msp.tudelft.nl

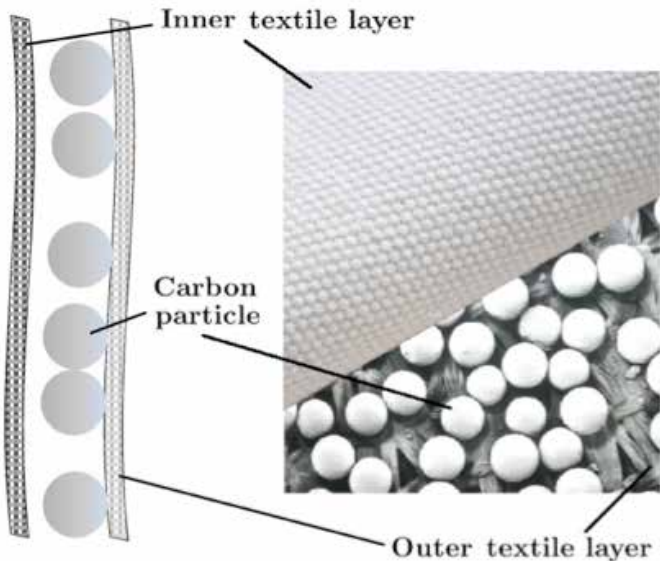

DYNAMIC BEHAVIOR OF TAYLOR FLOW IN DISTRIBUTED MICROREACTOR CHANNEL NETWORKS FOR LARGE-SCALE PROCESSING

PROJECT LEADERS

CR Kleijn, MT Kreutzer

RESEARCH THEME

Complex dynamics of fluids

PARTICIPANTS

Duong Anh Hoang

COOPERATIONS

TU Eindhoven (J.C. Schouten),
Wageningen University (K. Schroen),
OSPT-IROP (DSM, Shell, DOW,
Akzo-Nobel, Unilever, TNO)

FUNDED

STW, OSPT-IROP IROP (DSM,
Shell, DOW, Akzo-Nobel, Unilever,
TNO)

| | |
|--------------|------|
| University | - |
| FOM | - |
| STW | - |
| NWO Other | 75 % |
| Industry | 25 % |
| TNO | - |
| GTI | - |
| EU | - |
| Scholarships | - |

START OF THE PROJECT
2009

INFORMATION

CR Kleijn
015 278 2835
C.R.Kleijn@TUDelft.NL
www.msp.tudelft.nl

H Anh Duong
015 278 3210
h.a.duong@tudelft.nl
www.cheme.tudelft.nl

PROJECT AIM

Segmented flow is widely used in microreactor (Process-on-a-Chip and Lab-on-a-Chip) technology because of its high mass transfer, low axial dispersion and rapid micromixing. The generation and control of segmented flow in a single microchannel is well-established. Numbering up towards large-scale processing, however, required techniques for the stable and controlled distribution of segmented flows over networks of channels. As yet, techniques and fundamental understanding of such distributions are limited. In this project, we study the generation and transport of droplets and bubbles in microfluidic networks that comprise a large number of parallel microchannels. The aim is to understand how to form and distribute streams of bubbles or droplets in such networks.

PROGRESS

We formulated general design and scale-up rules for a breakup-based Taylor flow distributor for multiple microreactors.

DISSERTATIONS

-

SCIENTIFIC PUBLICATIONS

1. Duong A Hoang; Cees Haringa; Luis M Portela; Michiel T Kreutzer; Chris R Kleijn; Volkert van Steijn (2014). Design and characterization of bubble-splitting distributor for scaled-out multiphase microreactors. *Chemical Engineering Journal* 236 (2014), pp. 545-554.

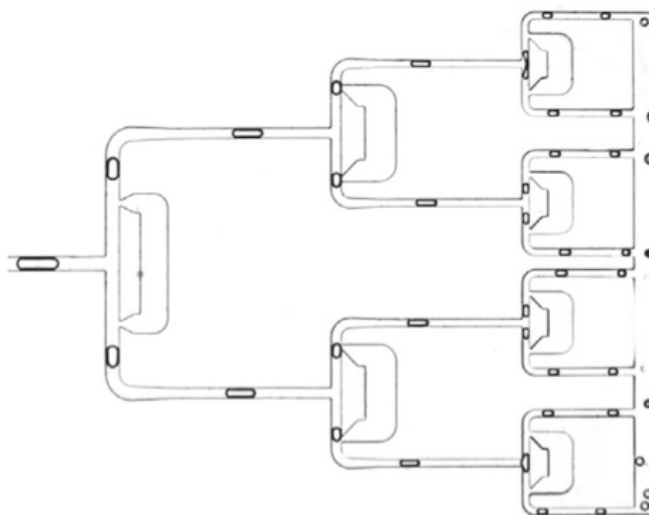

MULTIPHASE FLOW IN INTERNALLY STRUCTURED MICROCHANNELS UNDER PARTIAL WETTING CONDITIONS

PROJECT AIM

In this project we aim to understand behavior arising from partial wetting in multiphase flow in micro- and millifluidics. The partial wetting condition introduces additional fluids-solid interactions, which have a significant influence on the flow behaviour due to the dominance of capillary forces. A quantitative understanding of the fluids-solid interactions is of importance to accurately model the surface tension dominated multiphase flow. Therefore, the focus is on understanding and controlling the statics and quasi-static dynamics of the fluids-solid interface.

PROGRESS

To understand the complex interaction between a partially wetting liquid and a solid we have translated the two-phase micro/millifluidic system into a model system of a liquid droplet on an inclined solid substrate (see figure below). We use the Euler-Lagrange formalism to analytically calculate the energy minimum of a 2D droplet-surface system while accounting for the constraints on motion of the contact line of the droplet. We apply our understanding gained from this analytical approach to analyze the numerical results for 3D droplets. We find that families of droplets exist with equal volume and base width that all obtain the same shape at the onset of motion ($\alpha = \alpha_c$) and all have the same point of onset. Importantly, the history of the droplet, i.e. the way it was deposited on the surface, matters for the onset of motion. For more, see the PRL paper referenced below. With the insights gained from our energy minimization study we built a model that can predict the entire deformation process of a droplet when tilted from horizontal to roll-off. Crucially, this model accounts for the history of the droplet whereas currently available models ignore the history of the droplet completely.

DISSERTATIONS

-

SCIENTIFIC PUBLICATIONS

1. Droplets on Inclined Plates: Local and Global Hysteresis of Pinned Capillary Surfaces, Michiel Musterd, Volkert van Steijn, Chris R. Kleijn, and Michiel T. Kreutzer. *Physical Review Letters* 2014, 113 (6).
2. History dependent shape of droplets pinned to a substrate - towards a predictive model of droplet mobilization in partially wetting microreactors, Michiel Musterd, Volkert van Steijn, Chris R. Kleijn, and Michiel T. Kreutzer. In s.n. (Ed.), *Proceedings of the 4th European Conference on Microfluidics* (pp. 1-30). Limerick, 2014.

PROJECTLEADERS

CR Kleijn, MT Kreutzer

RESEARCHTHEME

Complex dynamics of fluids

PARTICIPANTS

M Musterd

COOPERATIONS

JM van Beek (UT), L Lefferts (UT), Shell, DOW, EGN, Sulzer

FUNDED

| | |
|--------------|-------|
| ISPT | |
| University | - |
| FOM | - |
| STW | - |
| NWO Other | - |
| Industry | 100 % |
| TNO | - |
| GTI | - |
| EU | - |
| Scholarships | - |

START OF THE PROJECT

2010

INFORMATION

M Musterd
015 278 7084
m.musterd@tudelft.nl
<http://cheme.nl/tp/musterd>

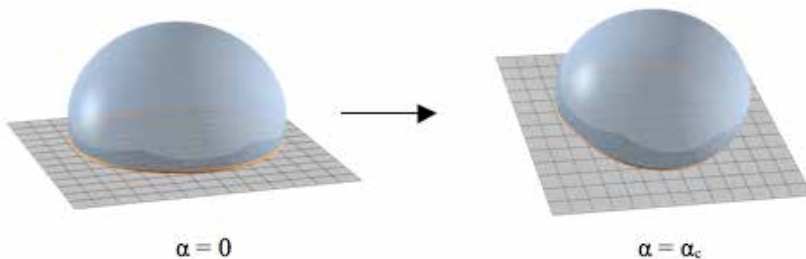

MODEL EXPERIMENTS ON IMPROVED CONTINUOUS STEEL CASTING THROUGH ELECTROMAGNETIC FLOW CONTROL

PROJECT LEADERS

CR Kleijn, S Kenjereš, M Tummers

RESEARCH THEME

Complex dynamics of fluids

PARTICIPANTS

R Kalter

COOPERATIONS

Tata steel, ABB

FUNDED

Tata steel, ABB, STW

University -

FOM -

STW 88 %

NWO Other -

Industry 12 %

TNO -

GTI -

EU -

Scholarships -

START OF THE PROJECT

2010

INFORMATION

R Kalter

r.kalter@tudelft.nl

015 212 82418

<http://cheme.nl/tp/people/kalter.shtml>

PROJECT AIM

The aim of the project is to provide a fundamental understanding of, and experimentally validated models for, the influence of electromagnetic fields on flow, turbulence and heat transfer in liquid steel during continuous casting. These insights and models will make it possible to design and to optimize new strategies for controlling steel casting processes, leading to significant energy savings, increased productivity and improved product quality.

PROGRESS

The flow from a submerged bifurcated nozzle into rectangular liquid filled cavities with width-to-thickness ratios $W/T = 6.5$, 11 and 18 has been studied using free surface visualization and particle tracking. When $W/T = 11$ and when $W/T = 18$, self-sustained oscillations of the submerged jets and the free surface are present. When $W/T = 6.5$ the self-sustained oscillations are no longer present, but oscillations with the frequency of gravity waves occur.

We propose a critical value of W/T above which self-sustained jet oscillations occur, based on the spreading angle of turbulent jets. When W/T is larger than this critical value, the shear layers of the jet reach the front and back wall of the cavity before the jet can impinge the side wall, resulting in semi two-dimensional flow in the plane between the front and the back wall. Two dimensional recirculation zones form alongside the jet leading to the jet oscillations. When W/T is smaller than this critical value, the jet can develop like a free turbulent jet up to an impingement point at the narrow side wall. When the jet impinges the side wall, flow in the directions parallel and perpendicular to the front and back walls is possible, resulting in complex three dimensional flow patterns. The critical value for W/T , based on the known 12° spreading angle of turbulent jets is $W/T = 10$, which is in good agreement with the experimental results.

DISSERTATIONS

-

SCIENTIFIC PUBLICATIONS

1. Kalter, R., Tummers, M.J., Kenjeres, S., Righolt, B.W. and Kleijn, C.R. Electromagnetic flow control in a rectangular cavity with a bifurcated nozzle. *International Journal of Heat and Fluid Flow*.
2. Kalter, R., Tummers, M.J., Kenjeres, S., Righolt, B.W. and Kleijn, C.R. Effects of electromagnetic forcing on self-sustained jet oscillations. *Physics of fluids*.
3. Kalter, R., Tummers, M.J., Kenjeres, S., Righolt, B.W., Wefers Bettink, J.B. and Kleijn, C.R. Aspect ratio effects on fluid flow fluctuations in rectangular cavities. *Metallurgical and Materials Transactions B*.
4. Kalter, R., Tummers, M.J., Kenjeres, S., Righolt, B.W. and Kleijn, C.R. Experimental modeling of heat transfer in a continuous casting mould model. *Proceedings of the ASME 2014 joint US-European Fluids Engineering Summer Meeting*.

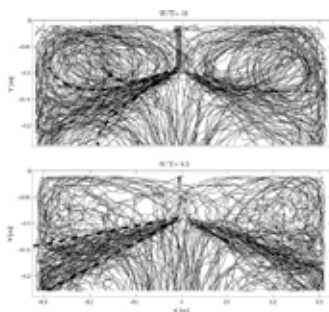

Pathlines obtained from particle tracking measurements for $W/T = 18$ (top) and $W/T = 6.5$ (bottom).

HYBRID RANS/LES SIMULATIONS OF TURBULENT FLOWS OVER HILLS AND COMPLEX URBAN AREAS WITH DISPERSION OF POLLUTANTS

PROJECT AIM

This project is part of the long-term investigations at former Department of Multi-Scale Physics and current Transport Phenomena Section aimed at the mathematical modelling and numerical simulations of environmental flows and turbulent dispersion of passive and reactive scalars. In this particular project we focus our investigation at turbulent flows over complex terrains and urban areas (street canyons) partially covered with vegetation and with different sources of the passive or reactive scalars. In the last year, the special focus was on the dynamics of reactive scalars to mimic the ozone generation or depletion.

PROGRESS

We developed a new class of the seamless hybrid RANS/LES approach suitable for the complex urban areas partially covered with vegetation. We successfully reproduced detailed laboratory-scale measurements for different geometrical configurations reported in literature. Also, the mechanism of the ozone generation or depletion in urban areas due to traffic emission is validated.

DISSERTATIONS

-

SCIENTIFIC PUBLICATIONS

1. Schrijvers P.J.C., Jonker H.J.J., de Roode S.R., Kenjeres S. (2014), "Simulating the day time and night time urban heat island effect on neighborhood scale", The 21st Symposium on Boundary Layers and Turbulence, 9-13 June, 2014, Leeds, UK., Paper 5A.7, Handout pp.1-18.

PROJECT LEADERS

S Kenjeres

RESEARCH THEME

Complex dynamics of fluids

PARTICIPANTS

S Kenjeres

COOPERATIONS

Prof. HJJ Jonker, CiTG TU Delft

Dr. SR Roode, CiTG, TU Delft

FUNDED

| | |
|--------------|-------|
| University | 100 % |
| FOM | - |
| STW | - |
| NWO Other | - |
| Industry | - |
| TNO | - |
| GTI | - |
| EU | - |
| Scholarships | - |

START OF THE PROJECT

2007

INFORMATION

S Kenjeres

015 278 3649

S.Kenjeres@tudelft.nl

www.msp.tudelft.nl

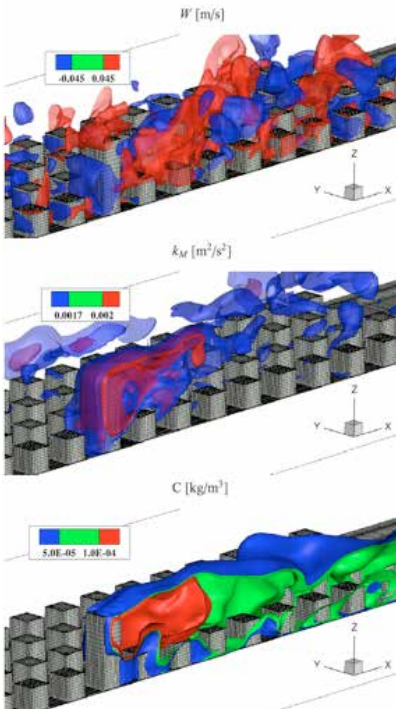

isosurfaces of the vertical velocity (red-negative, blue-positive), turbulent kinetic energy (k_M) and pollutant concentration (C) within a complex urban area with heating from the bottom plane and with emission of reactive scalars (the ozone depletion). An instantaneous snapshot from the new seamless hybrid RANS/LES method.

PROJECT LEADERS

S Kenjeres

RESEARCH THEME

Complex dynamics of fluids

PARTICIPANTS

S Kenjeres, JS Szmyd, E Fornalik-Wajs

COOPERATIONS

AGH University of Science and Technology, Krakow, Poland

FUNDED

AGH University of Science and Technology, Krakow, Poland, EC Marie Curie University 50 %
 FOM -
 STW -
 NWO Other -
 Industry -
 TNO -
 GTI -
 EU 50 %
 Scholarships -

START OF THE PROJECT

2007

INFORMATION

S Kenjeres
 015 278 3649
 S.Kenjeres@tudelft.nl
 www.msp.tudelft.nl

Iso-surfaces of the temperature for different strengths of the imposed magnetic field, $|b_0|_{max}=0$ and 2 T (i.e. the magnetization number is 0 and 2.34) and a fixed value of $Pr=400$ (the steady laminar flow regime of the paramagnetic fluid).

PROJECT AIM

This is a joint project between Transport Phenomena Section, Department of Chemical Engineering at the TU Delft and the Department of Fundamental Research in Energy Engineering, Faculty of Energy and Fuels, AGH University of Science and Technology, Krakow, Poland. The project is aimed at fundamental investigations of flow stability and wall heat transfer of paramagnetic fluids in presence of strong magnetic field gradients.

PROGRESS

Experimental measurements of the integral heat transfer performed over a range of working parameters for a differentially heated cubical enclosure of a paramagnetic fluid subjected to magnetic gradients of different orientation and strength. DNS studies of the flow and heat transfer performed and detailed comparison with experiments performed. Detailed insights into mechanism of the wall-heat transfer enhancement or suppression provided.

DISSERTATIONS

-

SCIENTIFIC PUBLICATIONS

1. Kenjeres S., Pyrda L., Fornalik-Wajs E. and Szmyd J. S. (2014), "Numerical and Experimental Study of Rayleigh-Benard-Kelvin Convection", Flow, Turbulence and Combustion, Vol.92 (1-2), pp.371-393.
2. Straczek T., Prendota W., Goc K., Jurczyk J., Kapusta Ch., Szpak A., Zapotoczny Sz., Nowakowska M., Kenjeres S., Szmyd J.S. (2014), "Study of magnetic nanoparticle dynamics in superparamagnetic fluids", Proceedings of the XXI Fluid Mechanics Conference, AGH-UST, Krakow, 15-18 June 2014, Krakow, Poland, pp.1-2 (extended abstract).
3. Wrobel W., Fornalik-Wajs E., Pleskacz L., Kenjeres S., Szmyd J.S. (2014), "An analysis of paramagnetic fluid thermal convection in a concentric annuli under strong magnetic field gradient", Proceedings of the 15th International Heat Transfer Conference, IHTC-15, August 10-15, 2014, Kyoto, Japan, Paper IHTC15-9950, pp.1-15.

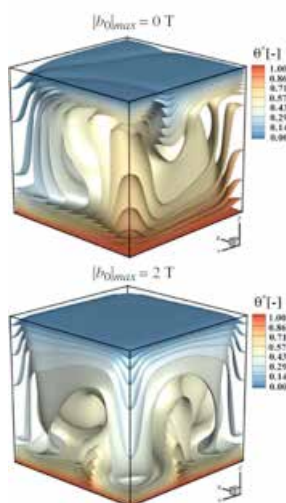

NUMERICAL SIMULATIONS AND EXPERIMENTS OF FLOW, TURBULENCE AND MASS TRANSFER CONTROL OF ELECTRICALLY CONDUCTING FLUIDS BY IMPOSED ELECTROMAGNETIC FIELDS

PROJECT AIM

Numerical cal simulations and modeling of thermal and magnetic convection at very high Rayleigh and Hartmann numbers has long been a serious challenge because of the profound effects that buoyancy and Lorentz forces have on the reorganization of the vortical structures, and because of the extreme thinning of the wall boundary layers which requires high numerical resolution. The aim of this study is to develop physically well-based and numerically efficient approaches to tackle problems of highly turbulent thermal and magnetic convection in complex geometries.

PROGRESS

We performed DNS studies of flow around magnetic obstacles in transitional and turbulent flow regimes. A new model for the subscale turbulent heat flux for low-Pr fluids is proposed.

DISSERTATIONS

-

SCIENTIFIC PUBLICATIONS

1. Kenjeres S. (2014), "Large Eddy Simulations of Turbulent Thermal Convection with Different Wall Configurations", Proceedings of 10th International ERCOFTAC Symposium on Engineering Turbulence Modelling and Measurements – ETMM10, 17-19 September, Marbella, Spain, S24, pp.1-8.
2. Kenjeres S. (2014), "Turbulent thermal convection in an enclosure with differently inclined horizontal wall: a LES study", Proceedings of the 15th International Heat Transfer Conference, IHTC-15, August 10-15, 2014, Kyoto, Japan, Paper IHTC15-9209, pp.1-12.
3. Shams A., Roelofs F., Baglietto E., Lardeau S. and Kenjeres S. (2014), "Assessment and calibration of an algebraic turbulent heat flux model for low-Prandtl fluids", Int. J. Heat and Mass Transfer, Vol.79, pp.589-601 (doi: 10.1016/j.ijheatmasstransfer.2014.08.018).

Instantaneous vertical vorticity in flow around magnetic obstacle(s) with laminar approaching conditions, $Re=1000$ and high electric conductivity

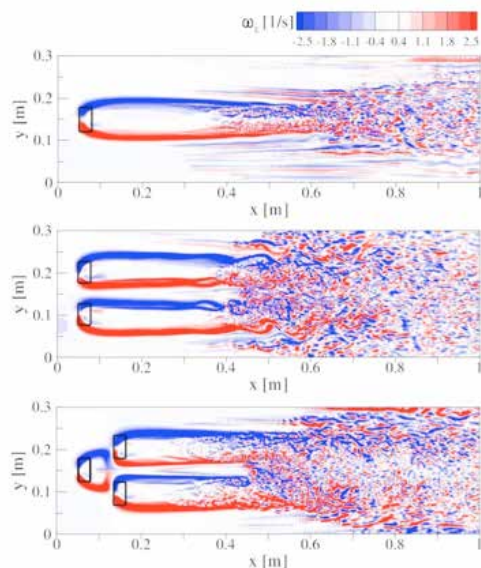

PROJECT LEADERS

S Kenjeres, CR Kleijn

RESEARCH THEME

Complex dynamics of fluids

PARTICIPANTS

S Kenjeres

COOPERATIONS

-

FUNDED

TU Delft

University 100 %

FOM -

STW -

NWO Other -

Industry -

TNO -

GTI -

EU -

Scholarships -

START OF THE PROJECT

2006

INFORMATION

S Kenjeres

015 278 3649

S.Kenjeres@tudelft.nl

www.msp.tudelft.nl

PROJECT LEADERS

S Kenjeres

RESEARCH THEME

Complex dynamics of fluids

PARTICIPANTS

S Kenjeres

COOPERATIONS

ERASMUS Medical Center
Rotterdam, Leiden University
Medical Center (LUMC)

FUNDED

| | |
|--------------|-------|
| TU Delft | |
| University | 100 % |
| FOM | - |
| STW | - |
| NWO Other | - |
| Industry | - |
| TNO | - |
| GTI | - |
| EU | - |
| Scholarships | - |

START OF THE PROJECT

2006

INFORMATION

S Kenjeres
015 278 3649
S.Kenjeres@tudelft.nl
www.msp.tudelft.nl

PROJECT AIM

One of the main problems of chemotherapy is often not the lack of efficient drugs, but the inability to precisely deliver and concentrate these drugs in affected areas. Failure to provide localized targeting results in an increase of toxic effects on neighboring organs and tissues. One promising method to accomplish precise targeting is magnetic drug delivery. Here, a drug is bound to a magnetic compound injected into the blood stream. The targeted areas are subjected to an external magnetic field that is able to affect the blood stream by reducing its flow rate. We believe that mathematical modeling and numerical simulations can significantly contribute to further advancements of this technique.

PROGRESS

We have developed a comprehensive mathematical model for simulations of blood-flow under the presence of strong non-uniform magnetic fields. The model consists of a set of Navier-Stokes equations accounting for the Lorentz and magnetization forces, and a simplified set of Maxwell's equations (Biot-Savart/Ampere's law) for treating the imposed magnetic fields. The model is then validated for different patient-specific geometries (including a carotid artery and brain vascular system).

DISSERTATIONS

-

SCIENTIFIC PUBLICATIONS

1. Kenjeres S. and de Looer A. (2014), "Modeling and Simulation of Low-Density-Lipoprotein (LDL) Transport Through Multi-Layered Wall of an Anatomically Realistic Carotid Artery Bifurcation", *Journal of the Royal Society Interface*, Vol.11 (91), Art. No. 2013094, pp. 1- 13 (doi: 10.1098/rsif.2013.0941).
2. Kenjeres S. (2014), "Keynote Lecture: Modelling and simulations of multi-physics multi-scale transport phenomena in bio-medical applications", *Proceedings of the XXI Fluid Mechanics Conference, AGH-UST, Krakow, 15-18 June 2014, Krakow, Poland, Journal of Physics: Conference Series, Volume 530, Art.No.01206, pp.1-20, (doi: 10.1088/1742-6596/530/01206).*

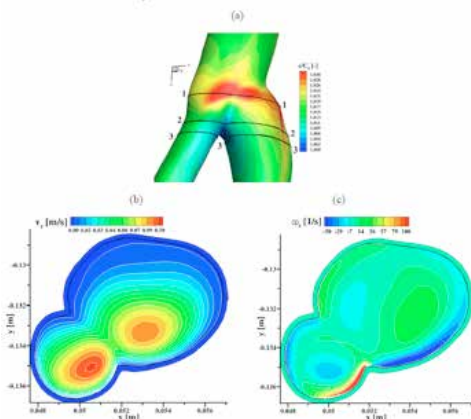

Numerical simulations of pulsating blood flow and magnetic drug targeting in the brain vascular system: The pressure (-left) and magnetic field (-right) distributions in a real patient brain vascular geometry, Kenjeres and Righolt (2012).

EXPERIMENTAL AND NUMERICAL INVESTIGATIONS OF TRANSITIONAL AND TURBULENT FLOWS OVER COMPLEX SURFACE WITH HEAT TRANSFER AND EMISSION OF PASSIVE SCALARS

PROJECT AIM

This is a joint project between Transport Phenomena Section, Department of Chemical Engineering at the TU Delft and the Laboratory for Transport Processes and Reactions of Prof. P. Rudolf von Rohr at ETH Zurich. The project addresses the combined experimental and numerical study of turbulent flows over complex surfaces with heat transfer and distribution of passive scalars. The final goal is to perform in parallel state-of-the-art experiments (stereo PIV, LIF, TLC) and numerical simulations (LES, hybrid RANS/LES, DES, RANS) for different wall configurations over a range of Reynolds numbers and intensities of the wall heat flux and scalar emissions.

PROGRESS

Experimental (PIV, LIF) and numerical studies (DNS, LES with dynamic Lagrangian SGS closure) performed for different configurations of narrow channels with a porous medium.

DISSERTATIONS

-

SCIENTIFIC PUBLICATIONS

1. Zenklusen A., Kenjeres S., Rudolf von Rohr P. (2014), "Vortex shedding in a highly porous structure", Chemical Engineering Science, Vol.106, pp.253-263 (doi: 10.1016/j.ces.2013.11.022).

PROJECT LEADERS

S Kenjeres, CR Kleijn

RESEARCH THEME

Complex dynamics of fluids

PARTICIPANTS

S Kenjeres, P Rudolf von Rohr,
A Zenklusen

COOPERATIONS

ETH Zürich, P. von Rohr

FUNDED

TU Delft, ETH Zurich, HPC-Europa 2

University 50 %

FOM -

STW -

NWO Other -

Industry -

TNO -

GTI -

EU 50 %

Scholarships -

START OF THE PROJECT

2006

INFORMATION

S Kenjeres

015 278 3649

S.Kenjeres@tudelft.nl

the wake structures and vortex shedding in dynamic LES simulation of the flow within a complex porous segment of a micro-reactor for which a detailed PIV and LIF measurements are performed at ETH.

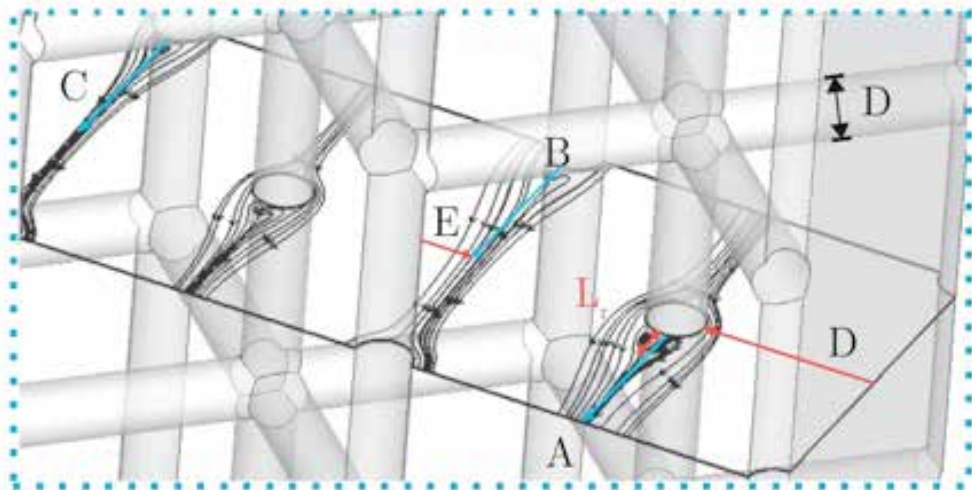

PERFORMANCE OF FOAMERS FOR DELIQUIFICATION OF GAS WELLS

PROJECT LEADERS

RAWM Henkes, L Portela

RESEARCH THEME

Complex structures of fluids

PARTICIPANTS

AT van Nimwegen

COOPERATIONS

NAM/Shell

FUNDED

NAM

University 25 %

FOM -

STW -

NWO Other -

Industry 75 %

TNO -

GTI -

EU -

Scholarships -

START OF THE PROJECT

2010

INFORMATION

RAWM Henkes

06 52096201

R.A.W.M.Henkes@tudelft.nl

PROJECT AIM

This project is a combined experimental/modeling study on the performance of foamers for deliquification of gas wells as used in the gas and oil industry. The reduction of the reservoir pressure for maturing fields will cause that gas wells will start to accumulate liquid (water, condensate). The use of proper foamer chemicals will mix the liquid and gas into a foam, which decreases the hydrostatic head in the well and re-establishes the flow. The study includes flow experiments using a 12 m, 5 cm diameter facility.

PROGRESS

Experiments were performed in three flow loops, which are now fully operational: the diameters of the flow loops are 34 mm and 50 mm (12 m in length) and 80 mm (18 mm in length). These results show that the effect of surfactants on air-water pipe flow can be understood in terms of the film at the wall of the pipe. The foam that is created when surfactants are present increases the film thickness and decreases the film density, making it easier for the air to drag the film upwards. As a result, surfactants reduce the pressure gradient at low gas flow rates. Surfactants are more effective for thinner liquid films: i.e. for lower liquid flow rates and smaller diameters. From this work, four more papers were written, which have been submitted or are soon to be submitted. The dissertation is finished in Q1 2015.

DISSERTATIONS

-

SCIENTIFIC PUBLICATIONS

1. A. T. van Nimwegen, L. M. Portela, and R. A.W. M. Henkes. The effect of surfactants on air-water annular and churn flow in vertical pipes. part 1: Morphology of the air-water interface. *International Journal of Multiphase Flow* (2014). doi: 10.1016/j.ijmultiphaseflow.2014.03.008.
2. A. T. van Nimwegen, L. M. Portela, and R. A.W. M. Henkes. The effect of surfactants on air-water annular and churn flow in vertical pipes. part 2: Liquid holdup and pressure gradient dynamics. *International Journal of Multiphase Flow* (2014). doi: 10.1016/j.ijmultiphaseflow.2014.03.007.
3. A. T. van Nimwegen, L. M. Portela, and R. A.W. M. Henkes. The effect of surfactants on the flow patterns in vertical air-water pipe flow. In *Proceedings of the ASME 2014 4th Joint US-European Fluids Engineering Division Summer Meeting, FEDSM2014-21845*, Chicago, (2014).



$D = 34 \text{ mm}$



$D = 50 \text{ mm}$



$D = 80 \text{ mm}$

SIMULATION OF AGGLOMERATION AND COATING NANOPARTICLES IN A FLUIDIZED BED

PROJECT AIM

The aim of this project is to study the complex agglomeration dynamics and mass transfer phenomena for the atomic layer deposition (ALD) on nanoparticles in the fluidized bed reactor. The challenge is to understand how nanoparticles agglomerate to loose dynamic clusters and the influence of the agglomeration on the coating process, such that uniform coatings can be made. A computational model will be developed to study the above problem by resolving each single nanoparticles.

PROGRESS

First, ALD type of surface reaction has been modeled with a sticking coefficient and a book-keeping of the available free sites at the surface in the direct simulation Monte Carlo (DSMC) method. The implementation in the DSMC solver in OpenFOAM is validated by studying the ALD surface coverage on a high aspect ratio trench, which showed a good agreement with the analytical and experimental data. Second, the immersed boundary method has been developed for the moving nanoparticles that are immersed in the gas flow, in order to avoid the grid regeneration at each time step. This method is validated by computing the drag force on the spheres at different parameters, which showed a good agreement with analytical and experimental data.

DISSERTATIONS

-

SCIENTIFIC PUBLICATIONS

-

PROJECT LEADERS

JR van Ommen, CR Kleijn

RESEARCH THEME

Mathematical and computational methods for fluid flow analysis

PARTICIPANTS

Wenjie Jin

COOPERATIONS

ASM

FUNDED

European Research Council (ERC)

University -

FOM -

STW 100 %

NWO Other -

Industry -

TNO -

GTI -

EU -

Scholarships -

START OF THE PROJECT

2012

INFORMATION

JR van Ommen

015 278 2133

J.R.vanOmmen@tudelft.nl

<http://cheme.nl/ppe/people/vanommen.shtml>

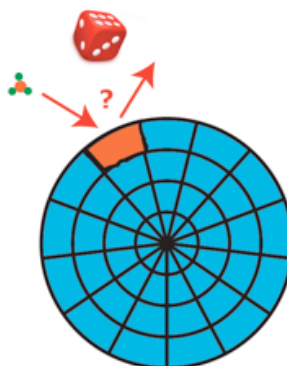
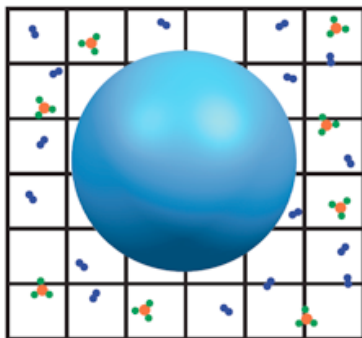

1 immersed sphere (left) and surface book-keeping method (right)

MODELLING THE INFLUENCE OF FLOW ON ASPHALTENE AGGLOMERATION AND DEPOSITION

PROJECT LEADERS

RAWM Henkes, LM Portela,
A Twerda

RESEARCH THEME

Mathematical and computational
methods for fluid flow analysis

PARTICIPANTS

KCJ Schutte

COOPERATIONS

TNO, ENI (ISAPP2)

FUNDED

| | |
|--------------|------|
| ENI | |
| University | 25 % |
| FOM | - |
| STW | - |
| NWO Other | - |
| Industry | 75 % |
| TNO | - |
| GTI | - |
| EU | - |
| Scholarships | - |

START OF THE PROJECT

2011

INFORMATION

RAWM Henkes
06 52096201
R.A.W.M.Henkes@tudelft.nl

PROJECT AIM

Asphaltenes are heavy organic deposits that can be formed when the oil transport from subsurface reservoirs undergoes a sharp drop in pressure. This can be at the inflow sections from the reservoir into the well bore, or inside the wellbore, pipeline, or downstream facilities. For example injection of chemicals can help to prevent blockage of the production system. Models are used for the design of asphaltene prediction, which in turn are used for the design of deposition prevention and remediation methods. Models used so far in the oil and gas industry are highly empirical. The aim of the present project is to better understand the fundamentals of the influence of flow on the agglomeration and deposition process of asphaltenes. This will result into both new detailed flow models, as well as into improved models that can be used in the industry.

PROGRESS

In the first two years of this project, a primary-particle based numerical model for flow-induced transport, agglomeration and break-up of a dispersed phase was developed. In 2014, this model was extended by considering also deposition and re-entrainment. An initial parameter study of the deposition model was conducted and it was found that deposition predominantly occurs close to the region where primary particles are injected in the computational domain (viz. the region where phase separation of asphaltenes occurs). Furthermore, the model was extended to allow studying pipe geometries in addition to the channel geometry considered so far in this project; currently, we are investigating to what extent the geometry of the domain influences the properties of the agglomerates formed, as well as the deposition and re-entrainment rates.

DISSERTATIONS

-

SCIENTIFIC PUBLICATIONS

-

Snapshot of deposit layer
formed in turbulent flow

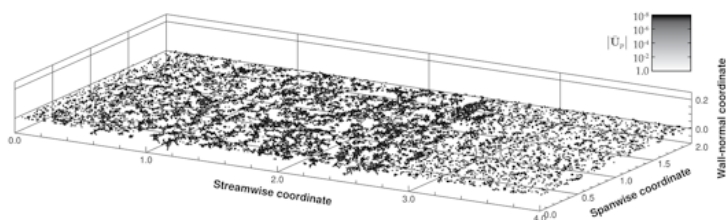

SIMULATIONS OF AGGREGATING SUSPENSIONS

PROJECT AIM

Separating fine solids from a continuous liquid phase in dense suspensions is often problematic given the very slow settling velocities of small (submicron) particles. Flocculation is a way to enhance settling speeds. For flocculation, a chemical agent (a "flocculant") that promotes aggregation of solids is mixed with the suspension. The aggregates ("flocs") settle much faster than the primary particles. In this research detailed numerical simulations of are used to better understand and optimize flocculation processes.

PROGRESS

An existing methodology for particle-resolved, direct simulations of suspensions has been equipped with an interaction potential so as to mimic aggregation. Subsequently increased settling speeds were observed in flocculating systems with enhanced settling strongly depending on interaction strength and (particle-based) Reynolds numbers.

DISSERTATIONS

-

SCIENTIFIC PUBLICATIONS

1. J.J. Derksen, Simulations of scalar dispersion in fluidized solid-liquid suspensions, *AIChE Journal*, Vol 60, p1880, 2014.
2. J.J. Derksen, Simulations of hindered settling of flocculating spherical particles, *International Journal of Multiphase Flow*, Vol 58, p127, 2014.

PROJECT LEADERS

JJ Derksen

RESEARCH THEME

Mathematical and computational methods for fluid flow analysis

PARTICIPANTS

JJ Derksen, Postdoc vacancy

COOPERATIONS

University of Alberta / IOSI

FUNDED

| | |
|--------------|------|
| IOSI | |
| University | 25 % |
| FOM | - |
| STW | - |
| NWO Other | - |
| Industry | 75 % |
| TNO | - |
| GTI | - |
| EU | - |
| Scholarships | - |

START OF THE PROJECT

2014

INFORMATION

JJ Derksen

015 278 6419

jj.derksen@tudelft.nl

<http://homepage.tudelft.nl/s0j2f/>

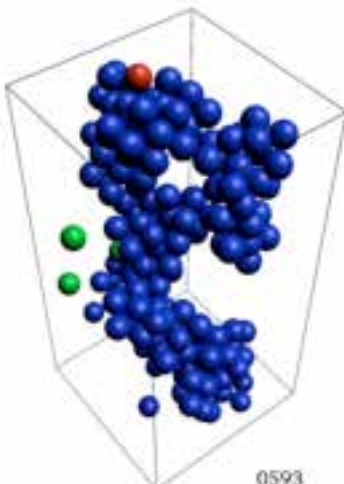

MULTISCALE MODELING OF DENSE SOLID SUSPENSION IN A STIRRED TANK

PROJECT LEADERS

JJ Derksen

RESEARCH THEME

Mathematical and computational methods for fluid flow analysis

PARTICIPANTS

JJ Derksen, Postdoc vacancy

COOPERATIONS

Solvay Research and Innovation

FUNDED

| | |
|--------------|-------|
| Solvay | |
| University | - |
| FOM | - |
| STW | - |
| NWO Other | - |
| Industry | 100 % |
| TNO | - |
| GTI | - |
| EU | - |
| Scholarships | - |

START OF THE PROJECT

2014

INFORMATION

JJ Derksen

015 278 6419

j.j.derksen@tudelft.nl

<http://homepage.tudelft.nl/s0j2f/>

PROJECT AIM

Results of detailed, particle-resolved simulations of flow and mass transfer in dense solid-liquid suspensions will be used to provide and tune parameters in closure and inter-phase exchange relations of coarser models (point-particle Eulerian/Lagrangian and Eulerian/Eulerian methods).

PROGRESS

An existing methodology for particle-resolved, direct simulations of suspensions has been applied to simulate the flow in a miniature mixing tank. We are also in the process of developing methods for mass transfer in dense suspensions at high Schmidt numbers.

DISSERTATIONS

-

SCIENTIFIC PUBLICATIONS

1. J.J. Derksen, Simulations of solid-liquid mass transfer in fixed and fluidized beds, *Chemical Engineering Journal*, Vol 255, p233, 2014.
2. J.J. Derksen, Simulations of solid-liquid scalar transfer for a spherical particle in laminar and turbulent flow, *AIChE Journal*, Vol 60, p1202, 2014.

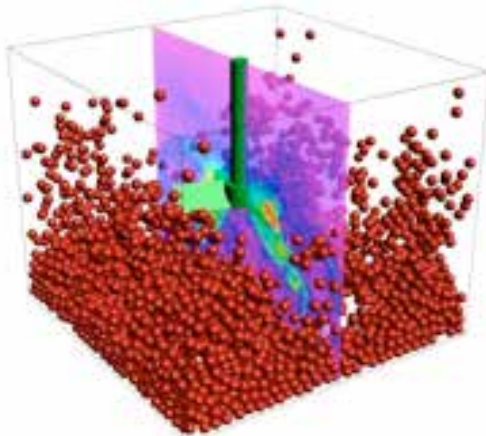

MODELING THE DYNAMIC BEHAVIOR OF REACTING COMPLEX FLUIDS IN NANOPORES: APPLICATION TO FISCHER- TROPSCH SYNTHESIS

PROJECT AIM

This project aims at understanding the physics of oil-water separation and their escape from a nanoporous network in a Fischer-Tropsch catalyst. Study of the separation physics requires integration of the transport phenomena and a thermodynamic description of the phase behavior. The objective of this project is to develop a multicomponent multiphase fluid flow solver that captures dynamics of reacting fluids inside nanopores. In this project, we wish to study the effect of surface wall heterogeneity of the nanopore confinement, in terms of reaction activity and wetting, on the demixing inside the nanopores in Fischer-Tropsch processes. These insights will help us optimize the process catalyst, improve catalyst life and increased catalyst selectivity.

PROGRESS

The solver development was carried forward from last year for this project. We completed validation of the diffusion solver with an improved performance in terms of unphysical concentrations. The diffusion-reaction solver was developed and validated for very simple reactions. The diffusion solver was coupled with the van der Waals equation of state. Currently, extension of the diffusion solver to multicomponent systems is underway. We also developed and validated the Cahn-Hilliard-Navier-Stokes coupled solver for a two-phase fluid. The flow solver was extended to model surface reactions. Development and validation of the dewetting boundary condition and the partial differential equation boundary condition were completed. Currently, the solver is being tested on different meshes (locally refined meshes). We are also investigating the effect of surface heterogeneities on flow profiles inside nanopores under different reaction conditions.

DISSERTATIONS

-

SCIENTIFIC PUBLICATIONS

-

PROJECT LEADERS

CR Kleijn, MT Kreutzer, V van Steijn

RESEARCH THEME

Complex dynamics of fluids

PARTICIPANTS

HG Pimpalgaonkar

COOPERATIONS

FOM, Shell

FUNDED

FOM, Shell

University -

FOM 50 %

STW -

NWO Other -

Industry 50 %

TNO -

GTI -

EU -

Scholarships -

START OF THE PROJECT

2013

INFORMATION

CR Kleijn

015 278 2835

C.R.Kleijn@tudelft.nl

HG Pimpalgaonkar

H.G.Pimpalgaonkar@tudelft.nl

015 278 7084

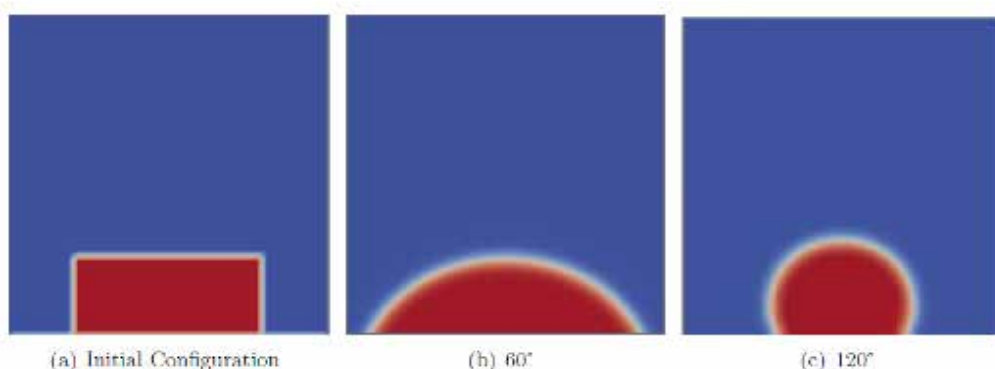

Results of the implementation of the wetting boundary condition. Blue and red regions represent two different immiscible fluids. (a) Initial configuration of two phases. This is a non-equilibrium state and droplet will relax depending on the contact angle input in the boundary condition. (b) Results for a contact angle of 60° (Partially wetting droplet) (c) Results for a contact angle of 120° (Partially dewetting droplet)

WATER PURIFICATION SYSTEM FOR ONE FAMILY IN THE DEVELOPING WORLD

PROJECT LEADERS

RF Mudde

RESEARCH THEME

Complex dynamics of fluids

PARTICIPANTS

Rajat Bhardwaj

COOPERATIONS

DrTen B.V.

FUNDED

DrTen B.V.

University -

FOM -

STW -

NWO Other -

Industry 100 %

TNO -

GTI -

EU -

Scholarships -

START OF THE PROJECT

2011

INFORMATION

R Bhardwaj

06 34423607

R.bhardwaj@tudelft.nl

PROJECT AIM

To develop an affordable solar distillation system for water purification. The still should be used by the poor in third world countries and hence should rely on solar energy only, have no high tech parts and should be cheap.

PROGRESS

We have investigated the effect of additional cooling on production of water inside a solar still and found that: The effect of increase in condensation area on the cooling capacity is favorable for increase in production of water in presence of limited resources; A six fold increase in the area of the condensation surface increased the production of water from the still by more than five times; Use of evaporation cooling increased the production of water from the solar still by more than 37%; A theoretical model for estimation of water production with increase in condensation area was developed. Further, we have also investigated the effect of contact angle on dripping of water from the ceiling of solar still and found that: Dripping inside a solar still increases with increase in contact angle of the material of the top ceiling; Dripping from hydrophobic surface (Teflon) reduces the production of water by more than 10 times when compared to dripping from the hydrophilic (glass) surface; Dripping from the top ceiling reduced the production of water by more than three times while using Teflon as a condensation surface inside the solar still.

DISSERTATIONS

-

SCIENTIFIC PUBLICATIONS

-

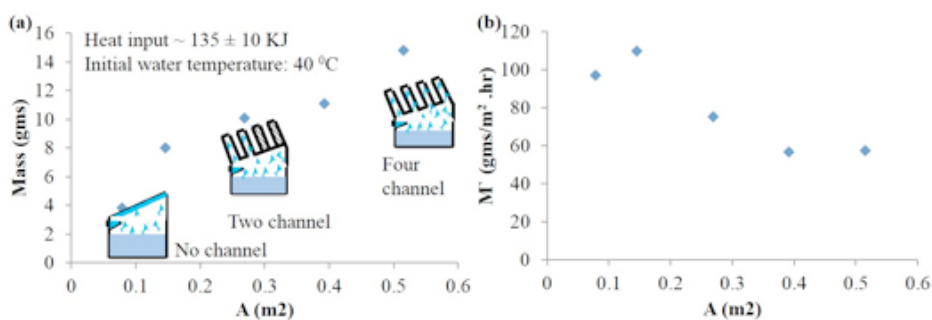

(a) Amount of mass produced from the solar still with increase in condensation area A. (b) Amount of mass produced from solar still normalized per unit area per hour

DEVELOPMENT OF AN OIL-WATER SEPARATOR: TOWARDS APPLICATION

PROJECT AIM

It has been shown by Laurens van Campen that bulk separation of oil and water can be achieved using in-line axial swirl elements. We would now like to mature the swirl separation technology such that is ready to be tested in an operating oil field. The industry partners have set the ambitious target of achieving 1000 ppm oil in the water stream since this would make swirl separation technology competitive relative to the large settling tanks that are currently used. In this phase of the project we are focusing on the design of the inner oil collector ('pickup tube', see figure 1) in order to significantly increase the separation efficiency.

PROGRESS

I started my post-doc on the 15th of September 2014. After an initial literature review phase and a meetings with industry partners, we have decided to focus our research efforts on optimizing the downstream geometry, especially the design of the pickup. The flow near the pickup tube is complex with flow separation, reversed flow and vortex stretching (see figure 2) all playing an important role. To this end, we have designed a stereoscopic-Particle Image Velocimetry (SPIV) experiment to investigate the structure of the flow in single phase (water) as depicted in figure 3. Our experimental plans and budget (~ €160,000) have just been approved by the industry partners and I am currently working on the detailed design of this experiment. Concurrently, we will perform a quick, starter experiment to investigate the separation efficiencies obtained by 'weak' swirl elements. The designs for the different swirl elements that we will be testing are shown in figure 4.

DISSERTATIONS

1. van Campen, L.J.A.M. 2014. Bulk Dynamics of Droplets in Liquid-Liquid Axial Cyclones. Ph.D. Thesis, Delft University of Technology, Delft, The Netherlands.

SCIENTIFIC PUBLICATIONS

-

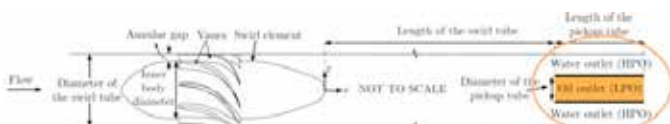

Swirl separator geometry. Current research focus is on optimising the downstream geometry to obtain higher separation efficiencies.

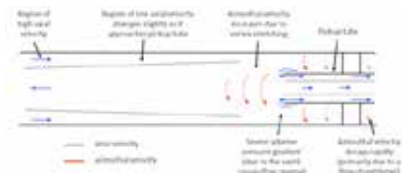

Flow near the pickup tube. Modified from the Ph.D thesis of Slot (University of Twente).

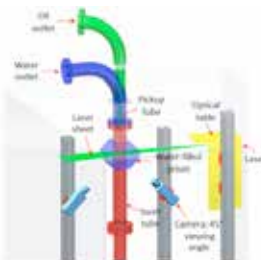

SPIV setup for investigating the structure of the flow near the pickup tube. Workshop at the Delft University of Technology.

PROJECT LEADERS

RF Mudde (Delft University of Technology), HWM Hoeijmakers (University of Twente), P Veenstra (Shell), J Bos (Frames), M Plantenga (ISPT)

RESEARCH THEME

Complex dynamics of fluids

PARTICIPANTS

Dr.ir. Ashok (TUD), Prof. dr. R.F. Mudde (TUD), Dr. ir. Jacco Hospers (UT), Prof. H.W.M. Hoeijmakers (UT)

COOPERATIONS

UT

FUNDED

Institute of Sustainable Process Technology, (Industry partners: Frames and Shell)

| | |
|--------------|-------|
| University | - |
| FOM | - |
| STW | - |
| NWO Other | - |
| Industry | 100 % |
| TNO | - |
| GTI | - |
| EU | - |
| Scholarships | - |

START OF THE PROJECT

2014

INFORMATION

RF Mudde
015 278 2834
R.F.Mudde@TUDelft.NL
www.cheme.nl/tp

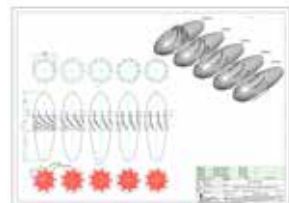

Drawings of the various swirl elements to be machined by the central

PROJECT LEADERS

RF Mudde

RESEARCH THEME

Complex dynamics of fluids

PARTICIPANTS

X Yang, JR van Ommen

COOPERATIONS

-

FUNDED

University 100 %

FOM -

STW -

NWO Other -

Industry -

TNO -

GTI -

EU -

Scholarships -

START OF THE PROJECT

2011

INFORMATION

RF Mudde

015 278 2834

r.f.mudde@tudelft.nl

PROJECT AIM

Study the hydrodynamics of various applications of fluidized beds using a fast X-ray tomographic system.

PROGRESS

We have investigated two different fluidized systems in which jets play a crucial role. On the one hand, we studied experimentally the dynamics of a spout in a spouted bed. The position of the spout as function of gas flow rate has been measured. From this a simple model for the motion of the solids has been derived. Secondly, micro jets in fine powders have been investigated. These jets assist in fluidizing cohesive particles. The jet stability and penetration depth have been found from the X-ray measurements. We found a good similarity with air jets from micro-nozzles in water, which is easier for experimenting and modeling.

DISSERTATIONS

-

SCIENTIFIC PUBLICATIONS

1. Yang, X., van Ommen, J.R., Mudde, R.F., Comparison of genetic algorithm and algebraic reconstruction for X-ray tomography in bubbling fluidized beds, Powder Technology, 253, 626-637, 2014.
2. Yang, X., van Ommen, J.R., Mudde, R.F., Time-resolved characterization of a flat-based spouted bed with a high speed X-ray system, Chem. Eng. Sci., 254, 143-152, 2014.

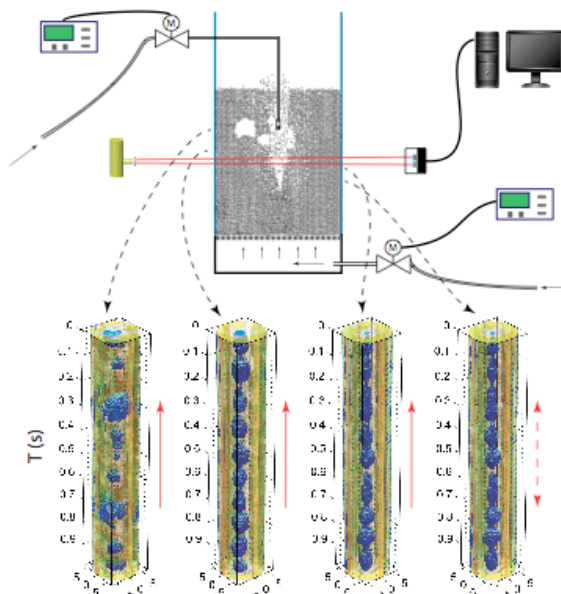

PROJECT AIM

The metabolic response of organisms in a fermentor depends on their environment, determined by the hydrodynamics, which may be spatially heterogeneous. The aim is to develop a computational fluid/reaction dynamics model that captures this heterogeneity. The results will serve as an input for laboratory experiments designed to study organisms in an industrially relevant environment; which is very relevant for the design of industrial fermentors.

PROGRESS

Particle-bound reaction model for *P. Chrysogenum* has been implemented and validated in FLUENT, yielding successful coupling between fluid and particle domain. Analysis of particle-lifelines has been initiated; work towards a final analysis strategy is ongoing. Stirred tank model has been updated, leading to better agreement with literature for single phase flow and multiple impellers. Extension allows utilizing domain symmetry and steady-state Eulerian hydrodynamics with transient Lagrangian dynamics to reduce computation time. This has been both implemented and validated in FLUENT. Steps towards multiphase (gas-liquid) simulations have been made, including implementation of mass transfer models.

DISSERTATIONS

-

SCIENTIFIC PUBLICATIONS

-

PROJECT LEADERS

RF Mudde

RESEARCH THEME

Mathematical and computational methods for fluid flow analysis

PARTICIPANTS

C Haringa

COOPERATIONS

ECUST Shanghai

DSM

Neil Tang MSc. (PhD/ECUST)

Prof. Henk J. Noorman (TUD, DSM)

Prof. Ju Chu (ECUST)

Dr. Jianye Xia (ECUST)

Prof. Joseph J. Heijnen (TUD)

Dr. Walter M. van Gulik (TUD)

Prof. Matthias Reuss (Univ. Stuttgart)

Dr. Wouter van Winden (DSM)

Dr. Amit T. Deshmukh (DSM)

FUNDED

NWO/MoST-Hé, DSM

University -

FOM -

STW -

NWO Other 50 %

Industry 50 %

TNO -

GTI -

EU -

Scholarships -

START OF THE PROJECT

2013

INFORMATION

C Haringa

015 278 7084

c.haringa@tudelft.nl

cheme.nl/TP

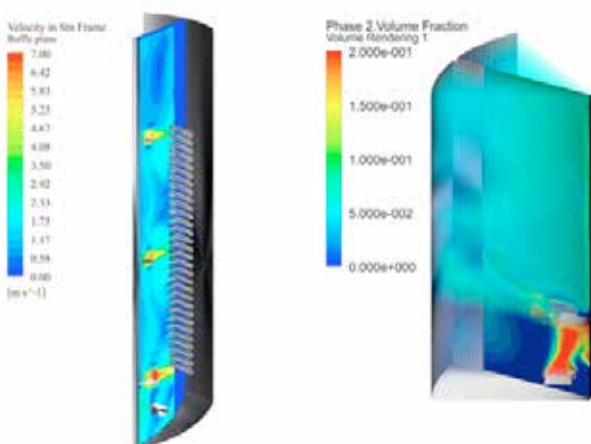

Left: Velocity contours in an industrial fermentor (3 Rushton impellers); Right: gas distribution in a pilot-scale fermentor

LATTICE BOLTZMANN MODELING OF MULTICOMPONENT-MULTIPHASE FLOWS UNDERGOING PHASE CHANGE WITH HIGH DENSITY RATIO

PROJECT LEADERS

HEA van den Akker

RESEARCH THEME

Mathematical and computational methods for fluid flow analysis

PARTICIPANTS

A Zarghami

COOPERATIONS

-

FUNDED

TU Delft, Shell, ISPT

University -

FOM -

STW -

NWO Other -

Industry 100 %

TNO -

GTI -

EU -

Scholarships -

START OF THE PROJECT

2014

INFORMATION

A Zarghami

06 17918693

a.zarghami-1@tudelft.nl

PROJECT AIM

The final aim of the project is to provide a numerical framework for simulating multi-component multi-phase catalytic systems using the Pseudopotential Lattice Boltzmann method. But, the selected model suffers from thermodynamics inconsistency, low density ratio and the large spurious velocities. Therefore, modeling multiphase flow at large density ratio and in the presence of spurious velocity is very challenging, because many issues should be addressed, simultaneously. Thus, at first we aim to address these issues through assessment of the model. Then, the study is expanded for multiphase flows undergoing phase change.

PROGRESS

Currently, the effects of spurious velocities on the thermo-hydrodynamic of a multi-phase system have been studied. Also, by analyzing the effective parameters of the model, we prospered to decrease the effects of the spurious velocities on the simulations and improve the stability of the model for very high density ratio systems. Now, we are working on the evaporating multi-phase flows.

DISSERTATIONS

-

SCIENTIFIC PUBLICATIONS

1. A. Zarghami, H.E.A. van den Akker, The effect of spurious velocities on transport phenomena in multiphase system, Netherlands Process Technology Symposium NPS14, 3-5 November 2014, Utrecht, The Netherlands.

a) simulation of a droplet, b) unphysical spurious velocities around the droplet and c) the effect of spurious velocity on the isothermal domain.

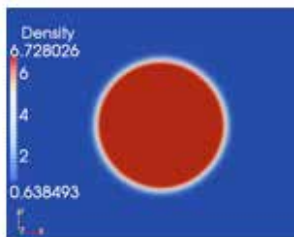

(a)

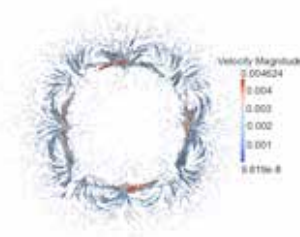

(b)

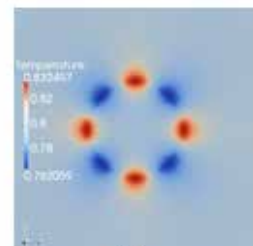

(c)

SIMULATING THE MESO-SCALE PROCESSES IN TWO-PHASE CHEMICAL REACTORS

PROJECT AIM

The aim of the project is to provide a numerical framework for simulating multi-phase catalytic chemical reactors using the Lattice Boltzmann (LB) method. The mesoscopic nature of the LB method allows for an efficient implementation of many relevant phenomena such as phase separation, mass and heat transfer, and catalytic surface chemistry. A large share of the project will deal with combining these implementations and validating the resulting framework using canonical cases from literature. The final part of the project will be to use the framework to analyze an existing chemical reactor on relevant issues such as the occurrence of hot-spot formation.

PROGRESS

The ongoing research has been on the LB implementation of a model which accounts for variable molecular masses in multi-component systems. Projects are being done on relating relevant multiphase macroscopic quantities such as surface tension and density ratios to LB simulation parameters. Also a project has started on investigating the effects of spurious velocities on mass transfer. A manuscript on the variation of the speed of sound in isothermal LBMs has been submitted to Phys. Rev. E and an journal paper on the implementation of this model in the simulation of a catalytic channel will be submitted shortly.

DISSERTATIONS

-

SCIENTIFIC PUBLICATIONS

1. Gillissen, J. J. J. and Looije, N., Boundary conditions for surface reactions in lattice Boltzmann simulations, Phys. Rev. E 89 6 (2014),

PROJECT LEADERS

HEA van den Akker

RESEARCH THEME

Mathematical and computational methods for fluid flow analysis

PARTICIPANTS

N Looije, JJJ Gillissen

COOPERATIONS

S Sundaresan (Princeton Uni.)

FUNDED

| | |
|---|-------|
| Shell Global Solutions, ISPT University | - |
| FOM | - |
| STW | - |
| NWO Other | - |
| Industry | 100 % |
| TNO | - |
| GTI | - |
| EU | - |
| Scholarships | - |

START OF THE PROJECT

2011

INFORMATION

N Looije

06 14975799

N.Looije-1@tudelft.nl



Prof.dr.ir. MT Kreutzer

The Product and Process Engineering (PPE) of the ChemE department of TU Delft views chemical engineering as an expanding field full of opportunities to create devices, processes and products. With expertise in reaction engineering, fluid mechanics and transport phenomena, we create solutions for soft-matter, nanotechnology, energy and lab-on-chip applications, often together with chemistry, physics and life-science groups. For us, engineering implies out-of-the-box thinking and design, from a sound basis in natural sciences with mathematics rigor. We are interested both in computational approaches and experimental work.

An important part of our work – led by Michiel Kreutzer – is related to the flow of droplets and bubbles in microchannels, with the aim of doing fun chemistry inside or outside those drops and bubbles. Each droplet can be seen as a miniaturized reactor that moves through a network on a chip as would a test tube through a chemistry lab. These flows are laminar, but the free interfaces bring in nonlinearities and instabilities, often driven by surface tension. Much of this work is done in cooperation with the group of prof. Chris Kleijn. There are lots of interesting chemistries that we deal with, ranging from catalysis to immiscible polymers.

Volkert van Steijn explores the use of aqueous polymer solutions to form droplets in an environment free of organic solvents and surfactants. Such droplets offer great potential for biomedical applications as they are fully biocompatible. In addition, he investigates the possibilities of using microfluidic devices for cell cultures.

Pouyan Boukany uses nanofluidics-based devices for providing quantitative insights into the fundamental mechanism of drug delivery, disease treatment, gene therapy and response of individual cells to therapeutic/ biomolecular reagents. In addition, he aims to understand the molecular dynamics of complex fluids using DNA as a model and advanced visualization techniques.

Ruud van Ommen is devoting an important part of his research efforts to dense gas-solid flows, where the solid phase consists of nanoparticles. In these systems, the nanoparticles cluster to form large, high-porosity agglomerates with fascinating interactions and flow properties. The aim is to chemically coat all individual nanoparticles in these agglomerates. He also studies gas-solid fluidized beds and three-phase systems with micron-sized particles, especially monitoring and structuring of these systems.

CONTINUOUS-FLOW SYNTHESIS OF CORE-SHELL NANOPARTICLES

PROJECT AIM

The aim of the project is to synthesize monodisperse core-shell nanoparticles with pre-defined properties, understand factors influencing the morphology (size, shape and dispersity), as well as applied these nanoparticles in catalysis.

PROGRESS

Progress in fabrication of microfluidic devices with well-established mixing, injection, cooling rate, multiple temperature zones for reactions carried out in compartments (droplets) dispersed in unreactive oils. We developed 2-layered PDMS devices for precise injection of fluid into moving droplets in order to synthesize Au-Ag core-shell nanoparticles with controlled shell thickness. Initial results of the synthesis of Au-Ag nanoparticles in microreactors shows that the coating of Au nanoparticles is improved in comparison with a batch mode synthesis. Progress was made also in modeling of the nucleation and growth of gold-citrate nanoparticles involving implementation of population balance into the model.

DISSERTATIONS

-

SCIENTIFIC PUBLICATIONS

-

PROJECTLEADERS

JR van Ommen, F Kapteijn,
MT Kreutzer

RESEARCHTHEME

Complex dynamics of fluids

PARTICIPANTS

B Kampa, V van Steijn

COOPERATIONS

Catalysis Engineering group of
ChemE, TU Delft

FUNDED

| | |
|----------------|-------|
| NRSC-Catalysis | |
| University | - |
| FOM | - |
| STW | - |
| NWO Other | 100 % |
| Industry | - |
| TNO | - |
| GTI | - |
| EU | - |
| Scholarships | - |

START OF THE PROJECT

2009

INFORMATION

BM Kampa
015 278 8188
b.m.kampa@tudelft.nl
www.cheme.tudelft.nl/ppe

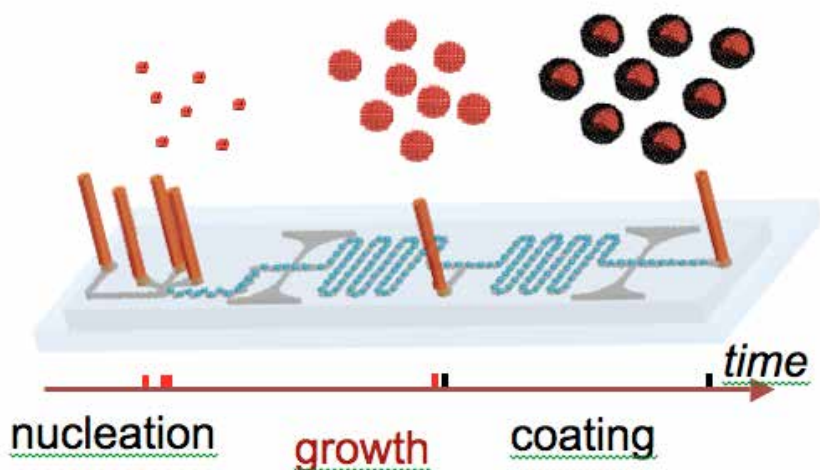

DYNAMIC BEHAVIOR OF TAYLOR FLOW IN DISTRIBUTED MICROREACTOR CHANNEL NETWORKS FOR LARGE-SCALE PROCESSING

PROJECT LEADERS

CR Kleijn, MT Kreutzer

RESEARCH THEME

Complex dynamics of fluids

PARTICIPANTS

Duong Anh Hoang

COOPERATIONS

TU Eindhoven (J.C. Schouten),
Wageningen University (K. Schroen)
OSPT-IROP (DSM, Shell, DOW,
Akzo-Nobel, Unilever, TNO)

FUNDED

STW, OSPT-IROP IROP (DSM,
Shell, DOW, Akzo-Nobel, Unilever,
TNO)

| | |
|--------------|------|
| University | - |
| FOM | - |
| STW | - |
| NWO Other | 75 % |
| Industry | 25 % |
| TNO | - |
| GTI | - |
| EU | - |
| Scholarships | - |

START OF THE PROJECT

2009

INFORMATION

CR Kleijn
015 278 2835
C.R.Kleijn@TUDelft.NL
www.msp.tudelft.nl

DA Hoang
015 278 7084
h.a.duong@tudelft.nl
<http://www.cheme.tudelft.nl>

PROJECT AIM

Segmented flow is widely used in microreactor (Process-on-a-Chip and Lab-on-a-Chip) technology because of its high mass transfer, low axial dispersion and rapid micromixing. The generation and control of segmented flow in a single microchannel is well-established. Numbering up towards large-scale processing, however, required techniques for the stable and controlled distribution of segmented flows over networks of channels. As yet, techniques and fundamental understanding of such distributions are limited. In this project, we study the generation and transport of droplets and bubbles in microfluidic networks that comprise a large number of parallel microchannels. The aim is to understand how to form and distribute streams of bubbles or droplets in such networks.

PROGRESS

We formulated general design and scale-up rules for a breakup-based Taylor flow distributor for multiple microreactors.

DISSERTATIONS

-

SCIENTIFIC PUBLICATIONS

1. Duong A Hoang; Cees Haringa; Luis M Portela; Michiel T Kreutzer; Chris R Kleijn; Volkert van Steijn (2014). Design and characterization of bubble-splitting distributor for scaled-out multiphase microreactors. *Chemical Engineering Journal* 236 (2014), pp. 545-554.

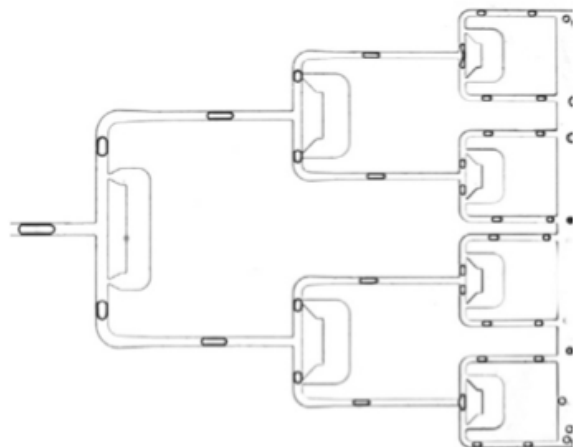

MODELING THE DYNAMIC BEHAVIOR OF REACTING COMPLEX FLUIDS IN NANOPORES: APPLICATION TO FISCHER-TROPSCH SYNTHESIS

PROJECT AIM

This project aims at understanding the physics of oil-water separation and their escape from a nanoporous network in a Fischer-Tropsch catalyst. Study of the separation physics requires integration of the transport phenomena and a thermodynamic description of the phase behavior. The objective of this project is to develop a multicomponent multiphase fluid flow solver that captures dynamics of reacting fluids inside nanopores. In this project, we wish to study the effect of surface wall heterogeneity of the nanopore confinement, in terms of reaction activity and wetting, on the demixing inside the nanopores in Fischer-Tropsch processes. These insights will help us optimize the process catalyst, improve catalyst life and increased catalyst selectivity.

PROGRESS

The solver development was carried forward from last year for this project. We completed validation of the diffusion solver with an improved performance in terms of unphysical concentrations. The diffusion-reaction solver was developed and validated for very simple reactions. The diffusion solver was coupled with the van der Waals equation of state. Currently, extension of the diffusion solver to multicomponent systems is underway.

We also developed and validated the Cahn-Hilliard-Navier-Stokes coupled solver for a two-phase fluid. The flow solver was extended to model surface reactions. Development and validation of the dewetting boundary condition and the partial differential equation boundary condition were completed. Currently, the solver is being tested on different meshes (locally refined meshes). We are also investigating the effect of surface heterogeneities on flow profiles inside nanopores under different reaction conditions.

DISSERTATIONS

-

SCIENTIFIC PUBLICATIONS

-

Results of the implementation of the wetting boundary condition. Blue and red regions represent two different immiscible fluids. (a) Initial configuration of two phases. This is a non-equilibrium state and droplet will relax depending on the contact angle input in the boundary condition. (b) Results for a contact angle of 60° (Partially wetting droplet) (c) Results for a contact angle of 120° (Partially dewetting droplet)

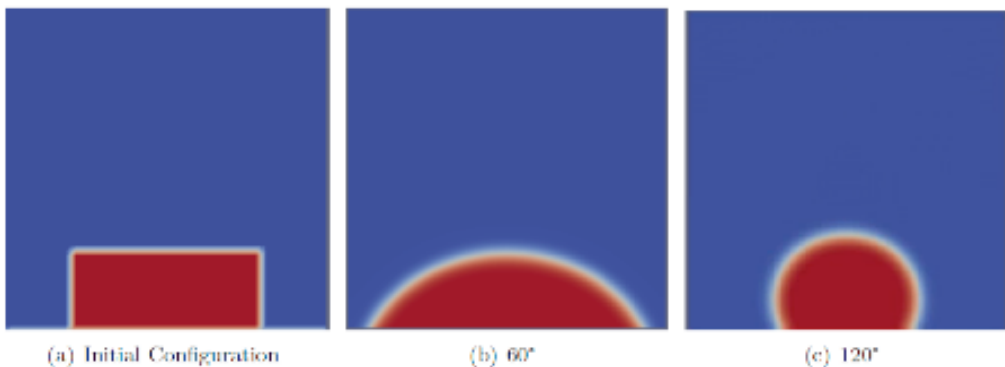

PROJECT LEADERS

CR Kleijn, MT Kreutzer, V van Steijn

RESEARCH THEME

Complex dynamics of fluids

PARTICIPANTS

HG Pimpalgaonkar

COOPERATIONS

FOM/Shell

FUNDED

FOM, Shell

University -

FOM 50 %

STW -

NWO Other -

Industry 50 %

TNO -

GTI -

EU -

Scholarships -

START OF THE PROJECT

2013

INFORMATION

CR Kleijn

015 278 2835

C.R.Kleijn@tudelft.nl

HG Pimpalgaonkar

015 278 7084

H.G.Pimpalgaonkar@tudelft.nl

MULTIPHASE FLOW IN INTERNALLY STRUCTURED MICROCHANNELS UNDER PARTIAL WETTING CONDITIONS

PROJECT LEADERS

CR Kleijn, MT Kreutzer

RESEARCH THEME

Complex dynamics of fluids

PARTICIPANTS

M Musterd

COOPERATIONS

JM van Beek (UT), L Lefferts (UT),
Shell, DOW, ECN, Sulzer

FUNDED

ISPT

University -

FOM -

STW -

NWO Other -

Industry 100 %

TNO -

GTI -

EU -

Scholarships -

START OF THE PROJECT

2010

INFORMATION

M Musterd

015 278 7084

m.musterd@tudelft.nl

<http://cheme.nl/tp/musterd>

PROJECT AIM

In this project we aim to understand behavior arising from partial wetting in multiphase flow in micro- and millifluidics. The partial wetting condition introduces additional fluids-solid interactions, which have a significant influence on the flow behaviour due to the dominance of capillary forces. A quantitative understanding of the fluids-solid interactions is of importance to accurately model the surface tension dominated multiphase flow. Therefore, the focus is on understanding and controlling the statics and quasi-static dynamics of the fluids-solid interface.

PROGRESS

To understand the complex interaction between a partially wetting liquid and a solid we have translated the two-phase micro/millifluidic system into a model system of a liquid droplet on an inclined solid substrate (see figure below). We use the Euler-Lagrange formalism to analytically calculate the energy minimum of a 2D droplet-surface system while accounting for the constraints on motion of the contact line of the droplet. We apply our understanding gained from this analytical approach to analyze the numerical results for 3D droplets. We find that families of droplets exist with equal volume and base width that all obtain the same shape at the onset of motion ($\alpha = \alpha_c$) and all have the same point of onset. Importantly, the history of the droplet, i.e. the way it was deposited on the surface, matters for the onset of motion. For more, see the PRL paper referenced below.

DISSERTATIONS

-

SCIENTIFIC PUBLICATIONS

1. Droplets on Inclined Plates: Local and Global Hysteresis of Pinned Capillary Surfaces, Michiel Musterd, Volkert van Steijn, Chris R. Kleijn, and Michiel T. Kreutzer. *Physical Review Letters* 2014, 113 (6).
2. History dependent shape of droplets pinned to a substrate - towards a predictive model of droplet mobilization in partially wetting microreactors, Michiel Musterd, Volkert van Steijn, Chris R. Kleijn, and Michiel T. Kreutzer. In s.n. (Ed.), *Proceedings of the 4th European Conference on Microfluidics* (pp. 1-30). Limerick, 2014.

With the insights gained from our energy minimization study we built a model that can predict the entire deformation process of a droplet when tilted from horizontal to roll-off. Crucially, this model accounts for the history of the droplet whereas currently available models ignore the history of the droplet completely.

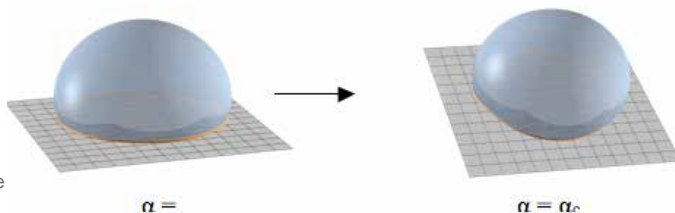

PROJECT AIM

Study the hydrodynamics of various applications of fluidized beds using a fast X-ray tomographic system.

PROGRESS

We have been testing the use of Genetic Algorithms to reconstruct limited data sets that we obtained from our X-ray set up. We have shown that a so-called Adaptive Genetic Algorithm out performs the traditional SART reconstruction technique in finding small objects. Hence, using AGA increases the spatial resolution. On the other hand, AGA renders more erratic shapes than SART. Moreover, AGA is slow and requires too long reconstruction times. Our results suggest that a combination of SART and AGA may be better and combine the advantages of both methods. This is currently under investigation.

We have used our X-ray facility to investigate the dynamics of a spouted bed: a fluidized system in which a central gas jet is blown creating a central spout. We have measured several spout features and derived a particle circulation model from the data. We estimated the stability of the spout size and position for various flow conditions.

We have measured the flow pattern and dynamics of a downward micro-nozzle system for fluidized bed. This system is expected to assist the fluidization of nano-particles. The time-resolved gas distribution is obtained by our X-ray facility. A stable bubbling flow is found with this system from our recent results.

DISSERTATIONS

-

SCIENTIFIC PUBLICATIONS

1. X. Yang, J.R. van Ommen, E. Wagner, and R.F. Mudde (2014). "Time-resolved characterization of a flat-base spouted bed with a high speed X-ray system." Chemical Engineering Journal 254: 143-152.
2. X. Yang, J.R. van Ommen and R.F. Mudde (2014). "Comparison of genetic algorithm and algebraic reconstruction for X-ray tomography in bubbling fluidized beds." Powder Technology 253: 626-637.

PROJECT LEADERS

RF Mudde, JR van Ommen

RESEARCH THEME

Mathematical and computational methods for fluid flow analysis

PARTICIPANTS

X Yang

COOPERATIONS

-

FUNDED

| | |
|--------------|-------|
| University | - |
| FOM | - |
| STW | - |
| NWO Other | - |
| Industry | - |
| TNO | - |
| GTI | - |
| EU | - |
| Scholarships | 100 % |

START OF THE PROJECT

2011

INFORMATION

RF Mudde
015 278 2834
r.f.mudde@tudelft.nl

CHARACTERIZING NANOPARTICLE AGGLOMERATION IN THE GAS-SOLID FLOWS

PROJECT LEADERS

JR van Ommen

RESEARCH THEME

Complex dynamics of fluids

PARTICIPANTS

L de Martín

COOPERATIONS

WG Bouwman, Andrea Fabre

FUNDED

ERC Starting Grant

University -

FOM -

STW -

NWO Other -

Industry -

TNO -

GTI -

EU 100 %

Scholarships -

START OF THE PROJECT

2012

INFORMATION

JR van Ommen

015 278 2133

J.R.vanOmmen@tudelft.nl

cheme.nl/ppe/people/vanommen.

shtml

PROJECT AIM

Understanding and controlling the agglomerating nature of nanoparticles in gas flows during coating, such that uniform coatings can be made.

Characterizing the agglomerates formed by the nanoparticles by means of fractal analysis. Unraveling the mechanism of formation and breaking of the agglomerates in the fluidized bed.

PROGRESS

We have shown that the agglomerates of nanoparticles are built up in three hierarchical level, each level having a distinct fractal dimension. We characterized the two smaller levels (up to $\sim 10 \mu\text{m}$) by means of spin-echo small angle neutron scattering. The largest scale (up to the full agglomerate size, $\sim 200 \mu\text{m}$) was characterized using a newly developed settling tube. Moreover, we proposed a model to model the van der Waals interaction between two agglomerates taking into account the properties of the nanoparticles (such as having a polar or apolar surface) and the fractal dimension of the agglomerates. Finally, we developed a methodology for faster simulations of Diffusion Limited Aggregation, a model for nanoparticle agglomeration.

DISSERTATIONS

-

SCIENTIFIC PUBLICATIONS

1. L. de Martín, W.G. Bouwman, J.R. van Ommen (2014). "Multidimensional nature of fluidized nanoparticle agglomerates." *Langmuir* 30: 12696-12702.
2. De Martín, L., A. Fabre and J.R. van Ommen (2014). "The fractal scaling of fluidized nanoparticle agglomerates." *Chemical Engineering Science* 112: 79-86.
3. De Martín, L., J. Sánchez-Prieto, F. Hernández-Jiménez and J.R. van Ommen (2014). "A settling tube to determine the terminal velocity and size distribution of fluidized nanoparticle agglomerates." *Journal of Nanoparticle Research* 16: 1.
4. K.R. Kuijpers, L. de Martín, J.R. van Ommen (2014). "Optimizing off-lattice Diffusion-Limited Aggregation." *Computer Physics Communications*: 185: 841-846.

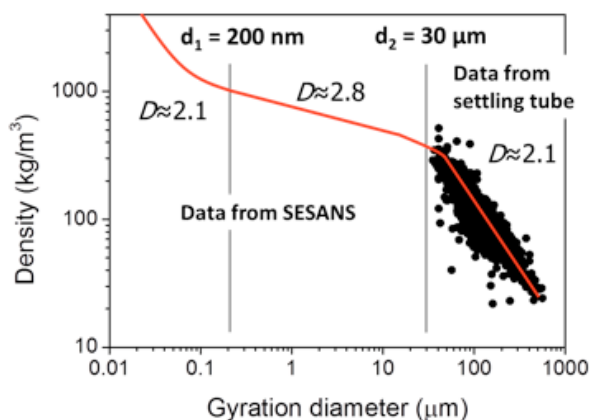

Fractal scaling of agglomerates of 20 nm nanoparticles

ELUCIDATING THE PHYSICS OF NANOPARTICLE INTERACTION AND CLUSTER DYNAMICS

PROJECT AIM

The aim is to investigate the interaction between individual nanoparticles, simple agglomerates and complex agglomerates. There will be a focus on the effect of surface modification on the previously studied interactions, and the development of techniques for efficient use of nanopowders from the acquired knowledge.

PROGRESS

Experimental and theoretical analysis of the fluidized agglomerate structure, focused on the fractal dimension, based on videos of free falling agglomerates in a fluidized bed. Simulations on agglomerate focusing for collision experiments. Finalized designs of experiments to study the properties, morphology, and behavior of fluidized agglomerates. Collision experiments, elasticity test, and 3D agglomerate imaging are in process.

DISSERTATIONS

-

SCIENTIFIC PUBLICATIONS

1. De Martin, L., A. Fabre and J.R. van Ommen (2014). "The fractal scaling of fluidized nanoparticle agglomerates." *Chemical Engineering Science* 112: 79-86.

PROJECT LEADERS

JR van Ommen, MT Kreutzer

RESEARCH THEME

Complex dynamics of fluids

PARTICIPANTS

A Fabre, W Jin, F Grillo

COOPERATIONS

School of Energy and Environment,
Southeast University, Nanjing, P.R.
China

FUNDED

European Research Council (ERC)
University -
FOM -
STW -
NWO Other -
Industry -
TNO -
GTI -
EU 100 %
Scholarships -

START OF THE PROJECT

2012

INFORMATION

JR van Ommen

015 278 2133

J.R.vanOmmen@tudelft.nl

cheme.nl/ppp/people/vanommen.shtml

shtml

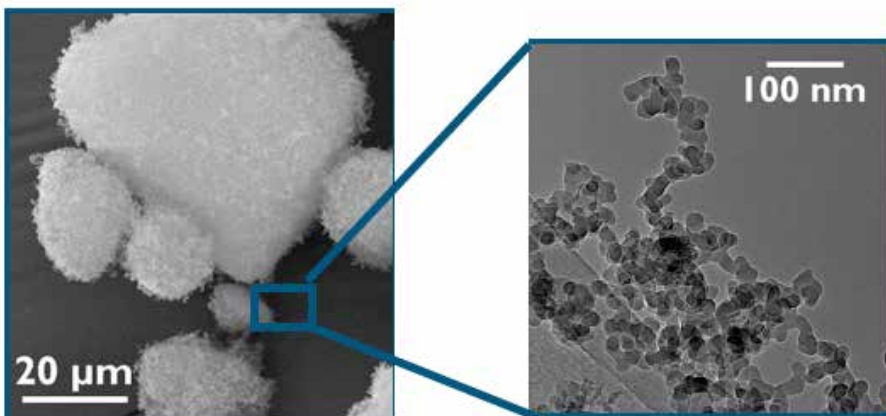

COATING FINE PARTICLES WITH ULTRATHIN FILMS USING ATOMIC LAYER DEPOSITION IN FLUIDIZED BED REACTORS

PROJECT LEADERS

JR van Ommen, GMH Meesters,
MT Kreutzer

RESEARCH THEME

Complex dynamics of fluids

PARTICIPANTS

D Valdesueiro, A Goulas

COOPERATIONS

-

FUNDED

| | |
|--|------|
| Marie Curie ITN program and DSM University | - |
| FOM | - |
| STW | - |
| NWO Other | - |
| Industry | 25 % |
| TNO | - |
| GTI | - |
| EU | 75 % |
| Scholarships | - |

START OF THE PROJECT

2011

INFORMATION

D Valdesueiro
015 278 9111
d.valdesueiro@tudelft.nl

PROJECT AIM

The goal of the project is the production of core-shell micron-sized particles, by using the coating technique called Atomic Layer Deposition (ALD). ALD can provide particles with thin layers. This process is carried out in a fluidized bed reactor. The particles are coated with two different aims. The first is to protect the core particle from degradation via e.g. oxidation or dissolution. The second one is to activate the surface of the particles by depositing valuable materials, such as a catalyst.

PROGRESS

We have worked on the optimization of the fluidization process, which is hindered by the tendency of the fine particles to form agglomerates. By using an external input of energy in form of mechanical vibration, microjet or mechanical agitation, the interparticle attractive forces, i.e. van der Waals interaction, can be overcome. We produced batches of core-shell structured material by depositing a layer of aluminum oxide by ALD, using trimethyl aluminum and water as gas-phase precursors. Furthermore, we have shown that gas phase deposition of alumina on particles can be carried out at room temperature and atmospheric pressure with nanoscale control over the film thickness.

DISSERTATIONS

-

SCIENTIFIC PUBLICATIONS

1. C. Soria-Hoyo, J.M. Valverde, J.R. van Ommen, P.E. Sánchez-Jiménez, L.A. Pérez-Maqueda, M.J. Sayagüés, "Synthesis of a nanosilica supported CO₂ sorbent in a fluidized bed reactor", *Applied Surface Science* 328: 548-553.
2. Goulas, A. and J.R. van Ommen (2014). "Scalable production of nanostructured particles using atomic layer deposition." *KONA Powder and Particle Journal* 31: 234-246.

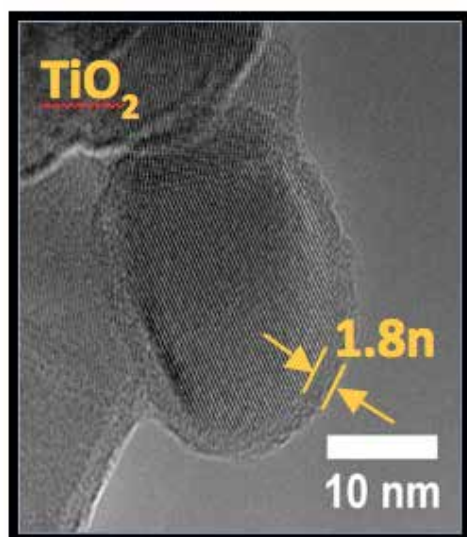

TiO₂ nanoparticle coated with a thin film of alumina in a fluidized bed reactor. With this technology, large amounts of particles can be coated.

SIMULATION OF AGGLOMERATION AND COATING NANOPARTICLES IN A FLUIDIZED BED

PROJECT AIM

The aim of this project is to study the complex agglomeration dynamics and mass transfer phenomena for the atomic layer deposition (ALD) on nanoparticles in the fluidized bed reactor. The challenge is to understand how nanoparticles agglomerate to loose dynamic clusters and the influence of the agglomeration on the coating process, such that uniform coatings can be made. A computational model will be developed to study the above problem by resolving each single nanoparticles.

PROGRESS

The aim of this project is to study the complex agglomeration dynamics and mass transfer phenomena for the atomic layer deposition (ALD) on nanoparticles in the fluidized bed reactor. The challenge is to understand how nanoparticles agglomerate to loose dynamic clusters and the influence of the agglomeration on the coating process, such that uniform coatings can be made. A computational model will be developed to study the above problem by resolving each single nanoparticles.

DISSERTATIONS

-

SCIENTIFIC PUBLICATIONS

-

PROJECTLEADERS

JR van Ommen, CR Kleijn

RESEARCHTHEME

Mathematical and computational methods for fluid flow analysis

PARTICIPANTS

W Jin

COOPERATIONS

ASM

FUNDED

European Research Council (ERC)

University -

FOM -

STW 100 %

NWO Other -

Industry -

TNO -

GTI -

EU -

Scholarships -

START OF THE PROJECT

2012

INFORMATION

JR van Ommen

015 278 2133

J.R.vanOmmen@tudelft.nl

cheme.nl/ppe/people/vanommen.

shtml

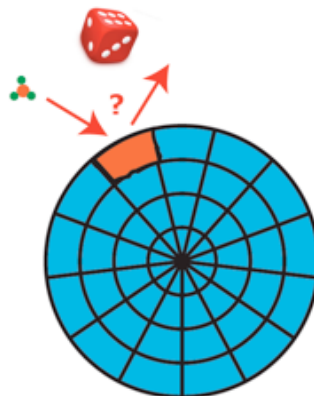
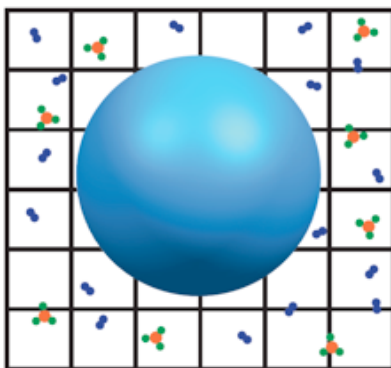

Immersed sphere (left) and surface book-keeping method (right)



Prof.dr.ir. ThJJ van der Hagen

MISSION

The reactor physics department contributes to the development of sustainable nuclear energy such that it can play a major role in the global energy production. To this end, we focus on new and innovative nuclear reactors with improved efficiency, a high degree of safety, flexibility, and with a reduced waste production.

RESEARCH

Research in the department can be divided into three categories:

1. Thermal Hydraulics of Nuclear Reactors
 - ♦ Experimental research on stability of natural circulation Boiling Water Reactors with enhanced safety features.
 - ♦ Numerical analyses of thermal-hydraulic phenomena in new reactors like the SBWR and others. This also includes method and code development.
 - ♦ Thermo-Siphon research.
2. Reactor Physics Analysis of New Reactor Designs
 - ♦ VHTR: Design and analysis of a gas-cooled Very High Temperature Reactor for hydrogen production. Focus on core design and safety/transient analysis.
 - ♦ GCFR: Design and analysis of a Gas-Cooled Fast Reactor with a self-generating core and reduced waste production.
 - ♦ ADS: Dynamics analysis and development of reactivity measuring methods for Accelerator Driven Systems.
 - ♦ MSR: Design and Analysis of a Molten Salt Reactor with a high-conversion and/or breeding fuel cycle. Focus on core design, fuel cycle analysis, and dynamics and safety analyses.
 - ♦ Exotic designs, like the Fluidized Bed Reactor with a fast neutron spectrum, the CANDLE burnup reactor, and reactors for new applications.
3. Methods and Codes for Reactor Physics and Particle Transport
 - ♦ Development and application of electron-photon-neutron particle transport, possibly coupled to other codes like CFD.
 - ♦ Development and application of Monte Carlo transport methods possibly coupled to other codes like deterministic transport codes, and CFD.
 - ♦ Development and application of new reactor physics methods, like - mode calculations, coupled time-dependent neutronics and thermal-hydraulics, etc.
 - ♦ Development of methods to reduce leakage of nuclides from a geological disposal site.

INVESTIGATION OF HEAT TRANSFER TO TURBULENT SUPERCRITICAL FLUIDS BY MEANS OF DIRECT NUMERICAL SIMULATION

PROJECT AIM

Heat transfer to supercritical fluids shows exotic behaviour, due to sharp fluid property gradients with respect to the temperature. As a result, it is difficult, if not impossible, to accurately predict heat transfer to such fluids using simple heat transfer relations. The goal of this project is to investigate the complex physics involved and to develop an accurate design correlation for the prediction of heat transfer to supercritical fluids. With Direct Numerical Simulations, it is possible to investigate the physics involved in great detail. These investigations will then be used for the design of a heat transfer relation.

PROGRESS

Three different numerical cases are currently considered. In case I, all thermo-physical properties are constant, while in cases II and III, the properties correspond to that of CO₂ at 8MPa. Upward mixed convection effects are considered only case III. The CO₂ cases have considerable property fluctuations, such that turbulence intensities are attenuated. The variations in thermo-physical properties are found to have a clear effect on near wall turbulent structures. In the forced convection case, the stream-wise vorticity structures are less apparent, while in the mixed convection case, the stream-wise vortices seem to have mostly disappeared near wall. Streaks become smaller in the forced convection case, while the opposite is true for the mixed convection case. This suggests that the near wall mechanism for sustaining turbulence is affected by the variable thermo-physical properties. This is currently under investigation.

DISSERTATIONS

-

SCIENTIFIC PUBLICATIONS

1. Peeters, J.W.R.; Pecnik, R.; Boersma, B.J.; Rohde, M.; van der Hagen, T. H. J. J.; Direct Numerical Simulation of heat transfer to CO₂ in an annulus at supercritical pressure; In proceedings of the 10th International ERCOFTAC Symposium on Engineering Turbulence Modelling and Measurements, Marbella, Spain, 17-19 September 2014.

PROJECT LEADERS

M Rohde

RESEARCH THEME

Mathematical and computational methods for fluid flow analysis

PARTICIPANTS

JWR Peeters, BJ Boersma,
R Pecnik, THJJ van der Hagen,
M Rohde

COOPERATIONS

-

FUNDED

| | |
|--------------|-------|
| STW-OTP | |
| University | - |
| FOM | - |
| STW | 100 % |
| NWO Other | - |
| Industry | - |
| TNO | - |
| GTI | - |
| EU | - |
| Scholarships | - |

START OF THE PROJECT

2012

INFORMATION

JWR Peeters
015 278 6628
j.w.r.peeters@tudelft.nl
<http://pe.tudelft.nl/node/603>

HEAT TRANSFER IN NON-UNITY PRANDTL NUMBER FLOWS (PART OF THINS PROJECT)

PROJECT LEADERS

M Rohde

RESEARCH THEME

Complex dynamics of fluids

PARTICIPANTS

NGW Warncke, V Valori,
DW de Haas, P van der Baan,
M Rohde

COOPERATIONS

University of Pisa, PSI, KTH

FUNDED

Euratom (EU)
University -
FOM -
STW -
NWO Other -
Industry -
TNO -
GTI -
EU 100 %
Scholarships -

START OF THE PROJECT

2010

INFORMATION

N Warncke
015 278 3811
n.g.w.warncke@tudelft.nl

PROJECT AIM

The aim of the project is twofold: The primary goal is to understand turbulent heat transfer in a supercritical fluid, in particular the so-called Onset of Heat Transfer Deterioration due to a re-laminarizing boundary layer in an upward flow. The second aim is to study the effect of turbulent mixing in a supercritical fluid on the temperature fluctuations in walls (thermal fatigue).

PROGRESS

The experimental facility was finished end of 2013. It consists of a closed loop filled with supercritical Trifluoromethane at 57 bar, with an annular flow around a cylindrical heating rod in the rising section. At the end of 2013, several first flow measurements were done using LDA, showing a profile of the average velocities and Reynolds stresses. Improvements, however, are required. Most difficult hurdle to overcome is the refraction of light, which is difficult to predict due to the radial variation of the density. A ray-tracing script has been written that should determine the beam crossing as accurate as possible. First measurements show that this ray-tracing program performs reasonably well. Final measurements are to be expected in June 2015.

The facility on mixing of three parallel, supercritical jets in a plenum has been completed. First measurements are expected in May 2015.

DISSERTATIONS

-

SCIENTIFIC PUBLICATIONS

-

Schematic of the vessel containing three parallel, supercritical jets. The inlet tubes for the jets are led into the vessel via the bottom flange. Most of the vessel is filled with aluminum to create a cylindrical domain. The three jets impinge on a wall, which is a thin membrane of copper foil. The vessel has five side flanges/looking glasses for PIV purposes. The top flange has a sapphire looking glass to gain optical access to the membrane. The temperature of the membrane is measured with IR spectroscopy. The working fluid is Freon R23 at a pressure of 57 bars and with an average temperature of 33.2 oC.

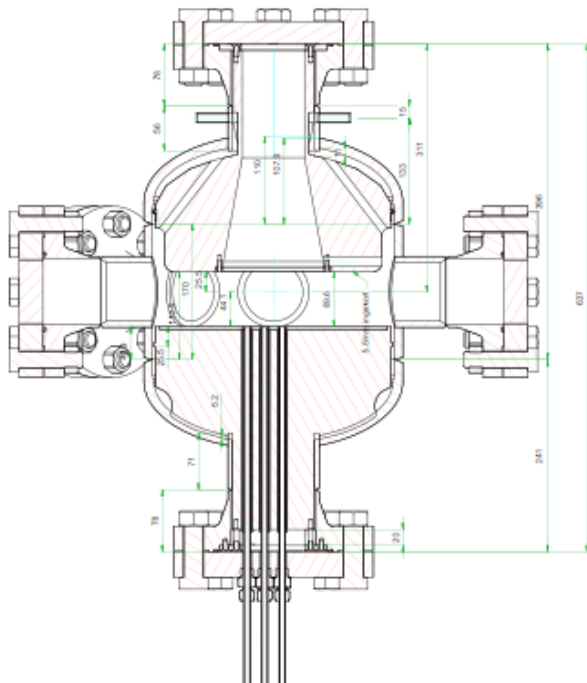

HEAT TRANSFER TO SUPERCRITICAL FLUIDS

PROJECT AIM

Study experimentally and theoretically heat transfer to supercritical fluids. The aim of the experimental study is to measure some relevant quantities characterizing the flow field (local velocities and their fluctuations within a plane and the Reynolds stress tensor calculated from them, for example); the experimental technique chosen to suit this purpose is Particle Image Velocimetry. The final aim of the project is to understand how the sharp change of properties around the critical point influences the flow field, the turbulence and the heat transfer effectiveness. This knowledge will be applied to improve existing turbulence models and heat transfer correlations.

PROGRESS

Study of Non-Boussinesq conditions in a Rayleigh-Benard cell at atmospheric pressure, in order to analyze the effect of variable properties on the fluid flow and turbulence. This is a preliminar study on the effect of variable property in preparation to the most complex case of fluid at supercritical pressure, where the effect of variable properties is stronger. PIV experiments in a Rayleigh Benard cell at non Boussinesq conditions: measurements of the mean velocities, of the RMS of the velocity components, of the turbulent kinetic energy and of the shear stress. The experiments have been done with three different fluids: water, methanol and Acetone, in order to study the effect of different Pr numbers on the fluid flow.

DISSERTATIONS

-

SCIENTIFIC PUBLICATIONS

-

PROJECTLEADERS

M Rohde

RESEARCHTHEME

Complex dynamics of fluids

PARTICIPANTS

V Valori, M Rohde, GE Elsinga, J Westerweel, THJJ van der Hagen

COOPERATIONS

-

FUNDED

| | |
|--------------|-------|
| STW | - |
| University | - |
| FOM | - |
| STW | 100 % |
| NWO Other | - |
| Industry | - |
| TNO | - |
| GTI | - |
| EU | - |
| Scholarships | - |

START OF THE PROJECT

2013

INFORMATION

V Valori

015 278 6821

v.valori@tudelft.nl



Prof.dr.ir. H Bijl



Prof.dr. F Scarano

The research in the Aerodynamics Group involves fundamentals of Fluid Dynamics and its applications to aerodynamic problems of relevance in Aerospace Engineering systems.

The activities cover boundary layer research in low speed and high-speed flows, including re-entry aero-thermodynamics, complex unsteady flows, fluid-structure interaction problems and aeroacoustics.

The group works in close connection with the Wind Energy section for the investigation of rotor blade aerodynamics. Specific flow control strategies by passive (e.g. vortex generators) and active means (suction, plasma actuators) are explored for their application in flow transition and separation delay.

The experimental research is supported by the Aerodynamics Laboratories, which cover flow simulation range from incompressible to hypersonic regime. Emphasis is given to the development and application of image based advanced flow diagnostic techniques like Tomographic PIV, Background Oriented Schlieren, InfraRed Thermography.

The study of Fluid-Structure interactions and of unsteady flow simulation drive the development of efficient simulation tools for 3D-unsteady viscous flows (e.g. adaptive meshing, mimetic methods, multiscale computation of turbulence). Applications range from flapping wings and micro aerial vehicle aerodynamics to aircraft flutter and unsteady loads on wind turbines. The research on CFD also covers quantification of uncertainties in aerodynamics problems simulation.

PIV + CFD – POSTPROCESSING VELOCITY FIELD DATA WITH CFD MODELS

PROJECT AIM

To combine PIV/PTV-like measurements of a flow with knowledge of the governing equations and boundary conditions, in order to perform:

1. Spatial/temporal reconstruction, and increasing data resolution in postprocessing
2. Reconstructing flow-fields from sparse data
3. Physics-based noise filtering
4. Accounting for particle dynamics in PIV/PTV post-processing.

PROGRESS

Figure 1 below shows an example of point 2. above. Data comes from only 100 particles measured with PTV procedures. Reconstruction by solution of an inverse problem, with a Vortex-in-Cell method providing the physics model. The combination gives a reconstruction of 3 vortex rings (right) – compared to adaptive Gaussian windowing (left) which is unable to identify any flow-features.

DISSERTATIONS

1. Jouke de Baar – Stochastic Surrogates for Measurements and Computer Models of Fluids – PhD Thesis, TU Delft, 2014.

SCIENTIFIC PUBLICATIONS

1. JFG Schneiders, RP Dwight, F Scarano, “Time-supersampling of 3D-PIV measurements with vortex-in-cell simulation”, Experiments in Fluids 55 (3), 1-15.
2. JHS de Baar, RP Dwight, H Bijl, “Improvements to gradient-enhanced Kriging using a Bayesian interpretation”, International Journal for Uncertainty Quantification 4 (3).
3. JHS de Baar, M Percin, RP Dwight, BW van Oudheusden, H Bijl, “Kriging regression of PIV data using a local error estimate”, Experiments in Fluids 55 (1), 1-13.
4. I Azijli, R Dwight, H Bijl, “A Bayesian Approach to Physics-Based Reconstruction of Incompressible Flows”, Numerical Mathematics and Advanced Applications-ENUMATH 2013, 529-536.

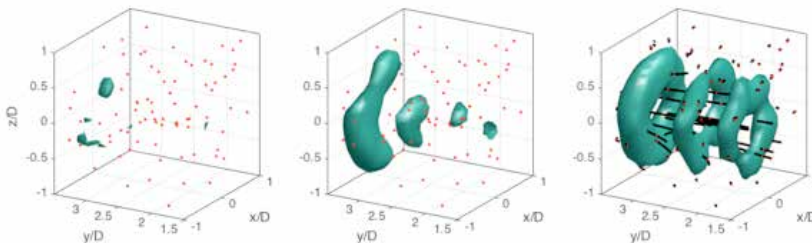

Very-sparse (100 particles, ppv ~ 1E-6) tomographic PTV; isosurfaces of Q criterion, left : Adaptive Gaussian Windowing (AGW), middle : VIC *without* particle tracks, right : VIC+ particle tracks.

PROJECTLEADERS

R Dwight, F Scarano

RESEARCHTHEME

Mathematical and computational methods for fluid flow analysis

PARTICIPANTS

J de Baar, I Azaili, J Schneiders

COOPERATIONS

Delft University of Technology, Lavision

FUNDED

| | |
|--|------|
| STW – MuST, TNO – JRP Radial compressor instability, Lavision University | - |
| FOM | - |
| STW | 40 % |
| NWO Other | - |
| Industry | 30 % |
| TNO | 30 % |
| GTI | - |
| EU | - |
| Scholarships | - |

START OF THE PROJECT

2011

INFORMATION

R Dwight

015 278 5773

R.P.Dwight@tudelft.nl

<https://aerodynamics.lr.tudelft.nl/~rdwight/>

PIV-BASED NON-INTRUSIVE DETERMINATION OF UNSTEADY AERODYNAMIC LOADS

PROJECT LEADERS

BW van Oudheusden, F Scarano,
FFJ Schrijer

RESEARCH THEME

Complex dynamics of fluids

PARTICIPANTS

PL Blinde, K Lynch, JFG Schneiders

COOPERATIONS

DNW, CNRS, DLR, Uni BW Munich,
University of Southampton, ONERA,
TU Berlin, Istanbul TU, Univ Calgary,
LaVision GmbH

FUNDED

EU FP-7 (NIOPLEX)
University 20 %
FOM -
STW -
NWO Other -
Industry -
TNO -
GTI -
EU 80 %
Scholarships -

START OF THE PROJECT

2006

INFORMATION

BW van Oudheusden
015 278 5349
B.W.vanOudheusden@tudelft.nl
<http://www.tudelft.nl/>

PROJECT AIM

Novel non-intrusive experimental approaches are developed and applied to determine the flow-field pressure, as well as the integral aerodynamic loads on objects, from flow velocity data measured with particle image velocimetry (PIV). This is achieved by combining the flow field information with basic momentum principles. Apart from looking at the fundamental principles (notably 3D flow effects) the project also addresses the development of practical procedures.

PROGRESS

- 1) Extension of PIV-based determination of mean pressure in a transonic base flow investigation with relevance to launcher-afterbody buffeting.
- 2) Theoretical study of PIV-based determination of instantaneous pressure in a transonic base flow, based on a numerical data set.
- 3) Continuation of the FP-7 funded collaborative project (NIOPLEX: www.nioplex.eu) in this research area, which is coordinated by TU Delft and involves an international consortium of 9 partners.

DISSERTATIONS

-

SCIENTIFIC PUBLICATIONS

1. P.L. Blinde, K.P. Lynch, B.W. van Oudheusden, J.F.G. Schneiders, F.F.J. Schrijer: Instantaneous pressure determination in a transonic base flow based on four-pulse tomographic PIV, 17th Int. Symposium on Applications of Laser Techniques to Fluid Mechanics, Lisbon, Portugal, 7-10 July 2014, 12 pp.
2. J.F.G. Schneiders, K.P. Lynch, R.P. Dwight, B.W. van Oudheusden, F. Scarano: Instantaneous pressure from single snapshot tomographic PIV by vortex-in-cell, 17th Int. Symposium on Applications of Laser Techniques to Fluid Mechanics, Lisbon, Portugal, 7-10 July 2014, 16 pp.

Pressure field in the transonic wake flow of a axisymmetric cylinder-afterbody model; left: mean pressure; right: pressure fluctuation level

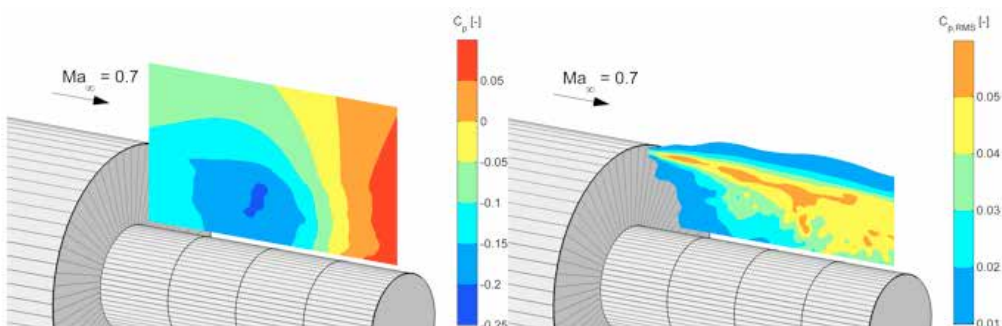

NANOSECOND DIELECTRIC BARRIER DISCHARGE (NS-DBD) PLASMA ACTUATOR FOR ACTIVE FLOW CONTROL

PROJECT AIM

to find the physical flow actuation mechanism due to nanosecond plasma actuators. Understanding of the physical principals of flow actuation is needed in order to be able to control the effect. Eventually, a strategy of flow actuation will be designed and tested.

PROGRESS

Research is begun with observations of the effect in still air, and in a 5 to 10 m/s flow on a flat plat, where flow actuation was not required. With this approach it has been possible to find out that the ns-DBD plasma actuator's flow control authority relies on a thermal effect. Such thermal effect introduces into the field of motion a disturbance that travels downstream and it is able to trigger naturally selected hydrodynamics instability of the flow field. Afterwards, application of the plasma technology on a backward facing step have reviled a frequency effect of the actuation mechanism. Such frequency effect has been studied and analyzed. So far, it has been possible to answer the two biggest questions about a nanosecond DBD plasma actuator's flow control capability: 1) where to place it and 2) what frequency it should operate in order to achieve a specific flow control task. Journal and Conference publications describing each the above topics have been submitted.

DISSERTATIONS

-

SCIENTIFIC PUBLICATIONS

1. G Correale, T Michelis, D Ragni, M Kotsonis, F Scarano Nanosecond-pulsed Plasma Actuation in Quiescent Air and Laminar Boundary Layer, Journal of Applied Physics: D, 2014.
2. G Correale, T Michelis, M Kotsonis NS-DBD plasma actuation on a backward facing step, 52st AIAA Aerospace Sciences Meeting, Washington, Maryland, USA, 2014.
3. R.Winkel, G.Correale, M.Kotsonis – Effect of dielectric material on thermal effect produced by ns-DBD plasma actuator – AiAA 2014.
4. Patent : G.Correale, I.Popov – 1260OPTWO/er – PCT/EP2013/067532 - Boundary layer control via nanosecond dielectric/resistive barrier discharge.

PROJECTLEADERS

M Kotsonis, G Correale

RESEARCHTHEME

Mathematical and computational methods for fluid flow analysis

PARTICIPANTS

G Correale

COOPERATIONS

-

FUNDED

Plasma Technology Development
B.V., TUDelft
University 50 %
FOM -
STW -
NWO Other -
Industry 50 %
TNO -
GTI -
EU -
Scholarships -

START OF THE PROJECT

2011

INFORMATION

G Correale
06 81351055
g.correale@tudelft.nl

PROJECT LEADERS

SJ Hulshoff, H Bijl

RESEARCH THEME

Mathematical and computational methods for fluid flow analysis

PARTICIPANTS

L Cheng, L Chen, G Maher, I Popov, P Fick

COOPERATIONS

Andrey Starikovskiy, Princeton.

FUNDED

| | |
|---|------|
| Chinese Scholarships Council (CSC), Plasma Technology Development B.V., STW, TUDelft University | 15 % |
| FOM | - |
| STW | 10 % |
| NWO Other | - |
| Industry | 25 % |
| TNO | - |
| GTI | - |
| EU | - |
| Scholarships | 50 % |

START OF THE PROJECT

2008

INFORMATION

S Hulshoff

015 2781538

s.j.hulshoff@tudelft.nl

PROJECT AIM

To combine low-order physical and numerical modeling techniques to minimize the cost of simulating viscous flow control problems. This includes the goal-oriented optimization of basis functions, stabilization parameters, and adaptation. The problems considered include transition control via plasma actuators, near-wall turbulent flows and fluid-structure interactions.

PROGRESS

Goal-oriented optimisation techniques for subgrid-scale modelling and mode identification have been further developed and applied to both linear and non-linear flow models. A method for application of variational Germano techniques to non-linear multiscale SGS models was developed. Results from the latter were compared to reference results obtained with goal-oriented techniques to identify specific sources of error in Germano methods. A thermodynamic model for NS-DBD developed previously in the project was applied to simulations of boundary layer transition and compared to experimental results.

DISSERTATIONS

-

SCIENTIFIC PUBLICATIONS

1. Chen, L, Edeling, WN & Hulshoff, SJ (2014). POD enriched boundary models and their optimal stabilisation. *International Journal for Numerical Methods in Fluids*, 2014, 1-16.
2. Chen, L, Maher, GD & Hulshoff, SJ (2014). Stabilisation parameter determination for the stokes equations. In E Onate, X Oliver & A Huerta (Eds.), *Proceedings of the jointly organized 11th. World Congress on Computational Mechanics - WCCM XI 5th. European Congress on Computational Mechanics - ECCM V 6th. European Congress on Computational Fluid Dynamics - ECFD VI* (pp. 6013-6024). online: International Center for Numerical Methods in Engineering (CIMNE).
2. Maher, GD & Hulshoff, SJ (2014). Numerical methods for the optimization of nonlinear residual-based subgrid-scale models using the Variational Germano Identity. In E Onate, X Oliver & A Huerta (Eds.), *Proceedings of the jointly organized 11th. World Congress on Computational Mechanics - WCCM XI 5th. European Congress on Computational Mechanics - ECCM V 6th. European Congress on Computational Fluid Dynamics - ECFD VI* (pp. 4676-4687). online: International Center for Numerical Methods in Engineering (CIMNE).
3. Cheng, L, Mattei, S, Fick, PW & Hulshoff, SJ (2014). A semi-continous formulation for goal-oriented reduced-order models. In E Onate, X Oliver & A Huerta (Eds.), *Proceedings of the jointly organized 11th. World Congress on Computational Mechanics - WCCM XI 5th. European Congress on Computational Mechanics - ECCM V 6th. European Congress on Computational Fluid Dynamics - ECFD VI* (pp. 4676-4687). online: International Center for Numerical Methods in Engineering (CIMNE).

COMPUTATIONAL SIMULATION OF NON-SYNCHRONOUS VIBRATIONS AND LOCK-IN PHENOMENON OF COMPRESSOR BLADES

PROJECT AIM

This project aims at the simulation and validation of non-synchronous vibrations and lock-in phenomenon of compressor blades. In general, non-synchronous vibrations occur due to the interaction of an aerodynamic instability with blade vibrations. These aerodynamic instabilities, typically encountered in turbo-machinery are dynamic separation, tip flow vortices and instabilities, and other secondary flows. Two modeling methods, the harmonic balance and the non-linear harmonics approach, will be investigated to describe the flow physics leading to non-synchronous vibration and lock-in.

PROGRESS

The harmonic balance and the non-linear harmonic approaches are applied to a two-dimensional, elastically mounted, cylinder test case, which experiences lock-in. The cylinder test case indicates whether both models are capable of sufficiently modeling the unsteady effects occurring during non-synchronous vibrations and model the lock-in effect. In a second phase a single row of a compressor is modeled, which, after validation, is extended with multiple rows.

DISSERTATIONS

-

SCIENTIFIC PUBLICATIONS

-

PROJECT LEADERS

AH van Zuijlen, H Bijl

RESEARCH THEME

Complex dynamics of fluids

PARTICIPANTS

M de Vries

COOPERATIONS

DLR, MTU Aero Engines

FUNDED

Faculty of Aerospace Engineering

University 100 %

FOM -

STW -

NWO Other -

Industry -

TNO -

GTI -

EU -

Scholarships -

START OF THE PROJECT

2013

INFORMATION

AH van Zuijlen

015 278 2046

A.H.vanZuijlen@tudelft.nl

www.lr.tudelft.nl/aerodynamics

EFFICIENT NUMERICAL SIMULATION TECHNIQUES FOR AEROELASTIC, AEROACOUSTIC AND FLUID-STRUCTURE-CONTROLLER INTERACTION PROBLEMS

PROJECT LEADERS

AH van Zuijlen, H Bijl

RESEARCH THEME

Mathematical and computational methods for fluid flow analysis

PARTICIPANTS

D Blom, L Florentie, T Gillebaart, SK Kamaludeen, D Mehta, W van der Velden, Y Zhang

COOPERATIONS

ECN, Siemens Wind Power, University of Stuttgart, Technical University München, University of Siegen, Technical University Darmstadt

FUNDED

Siemens Wind Power, German Research Foundation (DFG), EU, Shell, FOM, STW, CSC University -
FOM 14 %
STW 14 %
NWO Other -
Industry 28 %
TNO -
GTI -
EU 28 %
Scholarships 14 %

START OF THE PROJECT

2012

INFORMATION

AH van Zuijlen
015 278 2046
A.H.vanZuijlen@tudelft.nl
www.lr.tudelft.nl/aerodynamics

PROJECT AIM

This project combines the efforts of seven separate PhD projects that involve numerical simulation of wind energy related problems: from large scale (wind farms) to mid scale (rotor/blade) to small scale (vortex generators, trailing edge serrations). The applications include aero-elasticity, aero-acoustics and fluid-structure-controller-interactions. The aim is to reduce computational time of high-fidelity modeling through energy conserving discretizations (wind farm wake modeling), acceleration by low-fidelity models using multi-fidelity optimization techniques, and parallel partitioned coupling techniques to enable massively parallel fluid-structure-acoustic interaction.

PROGRESS

Application and validation: OpenFOAM is validated for a wind turbine blade with experimental data obtained in the Low Turbulence Tunnel in Delft. A full CFD and engineering model are compared for the aero elastic response of an airfoil experiencing a gust. The aero acoustic effect of serrations as noise suppression devices on wind turbine blades is modeled numerically using a Lattice Boltzmann approach. The ECNS (energy conserving) code is validated with experimental data obtained in the Open Jet Facility in Delft on an actuator disc model. Developments: OpenFOAM is coupled with preCICE to allow parallel simulation of fluid-structure-acoustic-interaction accelerated with multi-fidelity manifold mapping. A vortex particle method is implemented as low fidelity model for wind farm simulation/optimization. The effect of vortex generators is modeled by a body force model and optimized through an adjoint formulation.

DISSERTATIONS

-

SCIENTIFIC PUBLICATIONS

1. Mehta, D., van Zuijlen, A.H., Koren, B., Holierhoek, J.G., Bijl, H. Large Eddy Simulation of wind farm aerodynamics: A review. *Journal of Wind Engineering and Industrial Aerodynamics*, 133, pp. 1-17, 2014.
2. Mehta, D., Zuijlen, A.H. van, Bijl, H. Energy-conserving schemes for wind farm aerodynamics. *Journal of Physics: Conference Series* 524(1), art. no. 012157, 2014.
3. Zhang Y., Zuijlen, A.H. van, Bussel, G.J.W. van. Comparison of CFD simulations to non-rotating MEXICO blades experiment in the LTT wind tunnel of TUDelft. *Journal of Physics: Conference Series* 524(1), art. no. 012013, 2014.
4. Gillebaart T., Bernhammer, L.O., Zuijlen, A.H. van, Kuik, G.A.M. van. Active flap control on an aeroelastic wind turbine airfoil in gust conditions using both a CFD and an engineering model. *Journal of Physics: Conference Series* 524(1), art. no. 012060, 2014.
5. Blom, D.S., Zuijlen, A.H. van, Bijl, H. Acceleration of strongly coupled fluid-structure interaction with manifold mapping. In proceedings of WCCM XI – ECCM V – ECFD VI, pp. 4484-4495, 2014.
6. Gillebaart T., Tay, W.B., Zuijlen, A.H. van, Bijl, H. A modified ALE method for fluid flows around bodies moving in close proximity. *Computers and Structures* 145, pp. 1-11, 2014.

ADVANCES IMAGE ANALYSIS TECHNIQUES FOR PARTICLE IMAGE VELOCIMETRY AND PIV UNCERTAINTY ESTIMATORS

PROJECT AIM

Study of digital algorithms to increase the reliability and the dynamic range of velocity measurements by Particle Image Velocimetry. The work is based on the exploitation of time-sequences of 2D recordings or 3D reconstructions from tomographic PIV. Specific data analysis techniques are investigated to obtain a-posteriori error estimates from PIV experiments.

PROGRESS

Study of digital algorithms to increase the reliability and the dynamic range of velocity measurements by Particle Image Velocimetry. The work is based on the exploitation of time-sequences of 2D recordings or 3D reconstructions from tomographic PIV. Specific data analysis techniques are investigated to obtain a-posteriori error estimates from PIV experiments.

DISSERTATIONS

1. A. Sciacchitano, Uncertainty quantification in particle image velocimetry and advances in time-resolved image and data analysis, TU Delft, Promoter F. Scarano.

SCIENTIFIC PUBLICATIONS

1. K Lynch, F Scarano, Material acceleration estimation by four-pulse tomo-PIV, Meas. Sci. Technol. 25, 084005.
2. K Lynch, F Scarano, Experimental determination of tomographic PIV accuracy by a 12-camera system, Meas. Sci. Technol. 25, 084003.
3. DR Neal, A Sciacchitano, BL Smith, F Scarano, Collaborative framework for PIV uncertainty quantification: the experimental database, 17th Int. Symp. Appl. Laser tech. Fluid Mech., Lisbon.
4. A Sciacchitano, F Scarano, Elimination of PIV light reflections via a temporal high pass filter Meas. Sci. Technol. 25, 084009.
5. GE Elsinga, F Scarano, Characterization of PIV systems, Editorial special issue Meas. Sci. Technol. 25.

PROJECT LEADERS

F Scarano

RESEARCH THEME

Mathematical and computational methods for fluid flow analysis

PARTICIPANTS

A Sciacchitano, K Lynch

COOPERATIONS

LaVision GmbH, and US, Univ Utah, Virginia Tech

FUNDED

European Research Council

LaVision GmbH

University 25 %

FOM -

STW -

NWO Other -

Industry 75 %

TNO -

GTI -

EU -

Scholarships -

START OF THE PROJECT

2010

INFORMATION

F Scarano

015 278 5902

f.scarano@tudelft.nl

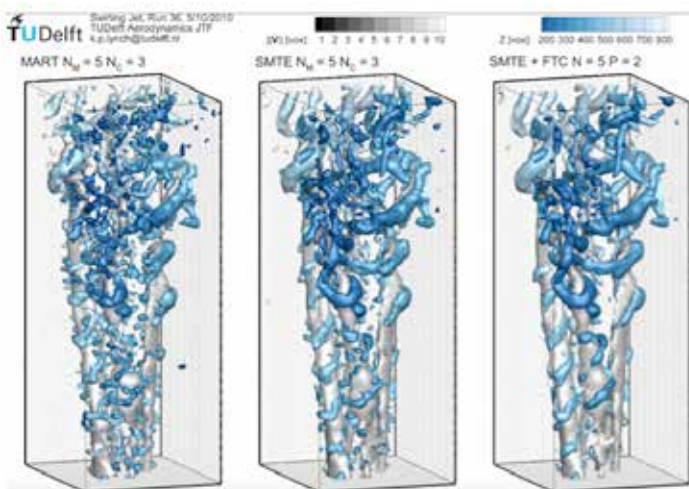

Instantaneous flow organization of a swirling jet measured with time-resolved tomographic PIV. Comparison between single pair cross-correlation analysis with single snapshot reconstruction (left) and SMTE-MART (middle). Multiframe analysis with Fluid Trajectory Correlation (right).

FLOVIST: FLOW VISUALIZATION INSPIRED AEROACOUSTICS BY TIME RESOLVED TOMOGRAPHIC PARTICLE IMAGE VELOCIMETRY

PROJECT LEADERS

F Scarano

RESEARCH THEME

Mathematical and computational methods for fluid flow analysis

PARTICIPANTS

M Novara, D Violato, S Ghaemi, A Ianiro, S Probsting

COOPERATIONS

Nationaal Luchtvaart Lab. (NLR), German Aerospace Centre (DLR), LaVision GmbH, University of Naples, University of Notre Dame

FUNDED

European Research Council (ERC)
University -
FOM -
STW -
NWO Other -
Industry -
TNO -
GTI -
EU 100 %
Scholarships -

START OF THE PROJECT

2008

INFORMATION

F Scarano
015 278 5902
f.scarano@tudelft.nl

PROJECT AIM

The FLOVIST project aims at advancing Tomographic PIV and extend its use towards the aeroacoustic analysis of turbulent flows of relevance in aerodynamics. The research is based on a number of milestones: 1) feasibility of time-resolved tomographic PIV in air flows; 2) realization of 3D pressure field measurements; 3) combining pressure-from-PIV approach with aeroacoustic analogies; 4) application to tonal noise problems and to broadband emissions from boundary layers and airfoil trailing edges.

PROGRESS

Experiments performed by high-resolution time-resolved tomographic PIV were performed on circular, chevron and swirled jets (collaboration with University of Naples). Acoustic source identification and mechanism associated to flow events at the jet core disruption. Time-resolved Tomo-PIV in a turbulent boundary layer and evaluation of the pressure from PIV technique for pressure coherence evaluation (collaboration with UniRoma, DNS simulations of TBL flow). Acoustic experiments performed at University of Notre Dame (US) in collaboration with prof. Scott Morris.

DISSERTATIONS

-

SCIENTIFIC PUBLICATIONS

1. S Pröbsting, J Serpieri, F Scarano, Experimental investigation of aerofoil tonal noise generation, Journal of Fluid Mechanics 747, 656-687.
2. S Pröbsting, F Scarano, Experimental investigation of isolated aerofoil noise, 21st Int. Congr. Sound Vibr.

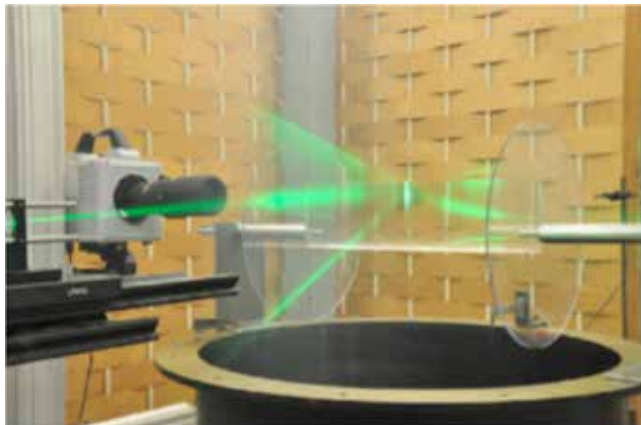

High-speed PIV measurements of transitional aerofoil emitting tonal noise

MACROPIV: TOWARDS LARGE SCALE TOMOGRAPHIC PARTICLE IMAGE VELOCIMETRY FOR INDUSTRIAL AERODYNAMICS

PROJECT AIM

The MACROPIV project explores technological developments leading to measurement capabilities of Tomographic PIV not available today. Time-resolved Tomo-PIV is nowadays practiced in measurement volumes not larger than that of a smartphone. Sub-millimetre neutrally buoyant tracers have the potential to an unprecedented upscale of measurement volumes as required for industrial aerodynamics (wind energy, automotive, aerospace, sports, among other sectors). The scale-up of production and non-intrusive utilization of Helium Filled Soap Bubbles (HFSB) is a primary milestone. The research involves the detailed study to determine flow regimes and conditions of applicability. The work is embedded in the coordinated effort of the aerodynamics section to develop non-intrusive experimental diagnostics for flow velocity and pressure in unsteady and turbulent flows.

PROGRESS

Evaluation of aerodynamic performances of HFSB tracers based on the response time principle. (collaboration with Alberta University). The experiment showed that a controlled stream of HFSB can be generated with response time in the order of 10 microseconds, making them suited for aerodynamic experiments in a broad range of the subsonic flow regime. Conceptual design, realization and optimization of transient storage-ejection system to seed wind tunnel flows. Application to cylinder wake flow in a volume of 20x20x10 cm³. Application to the study of a vertical axis wind turbine in the Open Jet Facility. Time-resolved Tomo-PIV has been demonstrated in a measurement volume of 40x20x15 cm³.

DISSERTATIONS

-

SCIENTIFIC PUBLICATIONS

1. F. Scarano, S. Ghaemi , G. Caridi , J. Bosbach , U. Dirksheide , A. Sciacchitano, On the use of helium-filled soap bubbles for large-scale Tomographic PIV wind tunnel experiments, 17th Int. Symp. Appl. Laser Tech. Fluid Mech., Lisbon.

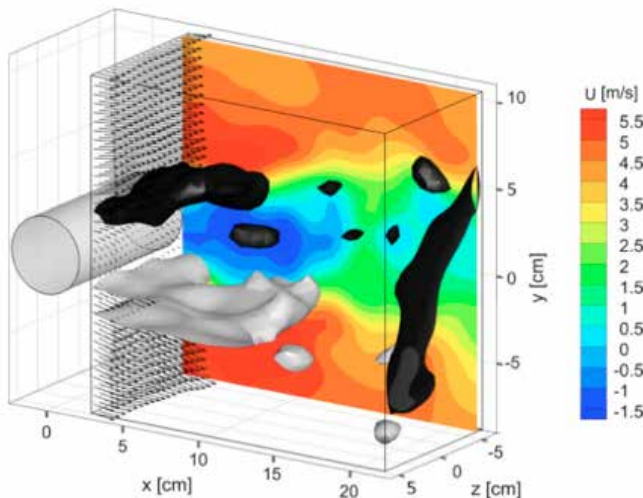

Instantaneous velocity and vorticity distribution in the wake of a cylinder. Dark and light grey iso-surfaces correspond to span-wise vorticity of ± 300 1/s, respectively.

PROJECT LEADERS

F Scarano

RESEARCH THEME

Mathematical and computational methods for fluid flow analysis

PARTICIPANTS

A Sciacchitano, G Caridi

COOPERATIONS

LaVision GmbH, German Aerospace Centre (DLR)

FUNDED

LaVision GmbH
University 50 %
FOM -
STW -
NWO Other -
Industry 50 %
TNO -
GTI -
EU -
Scholarships -

START OF THE PROJECT

2014

INFORMATION

F Scarano
015 278 5902
f.scarano@tudelft.nl

HELIUM FILLED SOAP BUBBLES FOR LARGE-SCALE TOMOGRAPHIC PIV EXPERIMENTS

PROJECT LEADERS

A Sciacchitano, F Scarano

RESEARCH THEME

Complex dynamics of fluids

PARTICIPANTS

G Caridi, A Sciacchitano, F Scarano

COOPERATIONS

LaVision GmbH

FUNDED

TUD

University 100 %

FOM -

STW -

NWO Other -

Industry -

TNO -

GTI -

EU -

Scholarships -

START OF THE PROJECT

2013

INFORMATION

A Sciacchitano

015 278 8692

a.sciacchitano@tudelft.nl

PROJECT AIM

The project aims at investigating the use of helium-filled soap bubbles (HFSB) as flow tracers for large-scale tomographic PIV experiments. Tomographic PIV is typically limited to measurement volumes up to 100 cm³ due to the low light intensity scattered by standard micrometric particles. To achieve measurement volumes of several thousands of cubic centimeter, the use of helium-filled soap bubbles (HFSB) is proposed due to their large size (diameter of 300 μm) and scattering efficiency. The project focuses on the aerodynamic characterization of the bubbles as flow tracers and the application of those for large-scale tomographic PIV experiments.

PROGRESS

In the last year, the flow-tracing fidelity of sub-millimeter diameter HFSB for speed aerodynamics has been investigated. Experiments have been conducted to compare the flow field measured with HFSB and standard fog droplets. The results showed the good tracing capabilities of the HFSB. The typical response time of the helium bubbles is of the order of 10 μs . A seeding system for increasing the concentration of tracer particles in the measurement region has been designed and developed. Time-resolved tomographic PIV experiments have been conducted in a low-speed wind tunnel at free-stream velocity of 5 m/s. The use of HFSB allowed measuring the Karman shedding of a circular cylinder in a measurement volume of 4,800 cm³.

DISSERTATIONS

-

SCIENTIFIC PUBLICATIONS

1. Scarano F, Ghaemi S, Caridi GCA, Bosbach J, Dierksheide U and Sciacchitano A (2015), On the use of helium-filled soap bubbles for large-scale tomographic PIV in wind tunnel experiments, *Exp Fluids* 56:42 DOI 10.1007/s00348-015-1909-7.

BLUFF BODY LEADING EDGE SEPARATION UNDER THE INFLUENCE OF STRONG PRESSURE GRADIENTS DUE TO OFFSET ELEMENTS: APPLICATION ON TRUCK SIDE-MIRRORS

PROJECT AIM

Improving the aerodynamics of the side-view mirror of a truck for drag reduction, especially in side-wind conditions. A combination of active and passive flow control means will be developed and tested in a truck prototype under realistic driving conditions. The active flow control devices of choice are AC-DBD plasma actuators.

PROGRESS

Flow around a cylinder that is placed in proximity to the leading edge of an elongated bluff body has been characterized using time resolved Particle Image Velocimetry at Reynolds numbers in the order of 104. This experiment provided physical insight in the combination of two previously studied scenarios: (i) wall bounded cylinder; (ii) leading edge separation bubble from an elongated bluff body. Particle Image Velocimetry was implemented for measuring a full-scale mirror from DAF at Reynolds numbers in the order of 105. The experimental data is used for tuning the numerical solvers of DAF as well as for determining the base flow on which a suitable and realistic control technique will be applied. Control of the mirror flow on DAF trucks has been successfully implemented using AC-DBD plasma actuators. The system involved a hybrid passive-active approach where the AC-DBD actuators are working in conjunction with passive guide vanes. An increase of up to 25 % in wake momentum at the center of the mirror has been achieved experimentally in full scale cruise conditions. A prototype is being developed for a field test.

DISSERTATIONS

-

SCIENTIFIC PUBLICATIONS

1. Cylinder in the vicinity of a bluff body leading edge. 44th AIAA Fluid Dynamics Conference. Theodoros Michelis, Marios Kotsonis.
2. Hybrid flow control of a transport truck side-mirror using AC-DBD plasma actuated guide vane. 67th Annual Meeting of the APS Division of Fluid Dynamics. Theodoros Michelis, Marios Kotsonis.
3. Interaction of an off-surface cylinder with separated flow from a bluff body leading edge. Experimental thermal and fluid science. Theodoros Michelis, Marios Kotsonis.

PROJECT LEADERS

M Kotsonis

RESEARCH THEME

Complex dynamics of fluids

PARTICIPANTS

T Michelis

COOPERATIONS

DAF, CRF

FUNDED

| | |
|--------------|------|
| EU, TUDelft | |
| University | 25 % |
| FOM | - |
| STW | - |
| NWO Other | - |
| Industry | - |
| TNO | - |
| GTI | - |
| EU | 75 % |
| Scholarships | - |

START OF THE PROJECT

2013

INFORMATION

T Michelis

015 278 9111

t.michelis@tudelft.nl

PROJECT LEADERS

H Bijl, B.W. van Oudheusden

RESEARCH THEME

Complex dynamics of fluids

PARTICIPANTS

W.B. Tay, M. Percin, S. Deng

COOPERATIONS

Univ. Michigan, AFRL

FUNDED

STW

University -

FOM -

STW 75 %

NWO Other -

Industry -

TNO -

GTI -

EU -

Scholarships 25 %

START OF THE PROJECT

2010

INFORMATION

B.W. van Oudheusden

015 278 5349

B.W.vanOudheusden@tudelft.nl

www.tudelft.nl/

PROJECT AIM

The project considers fundamental and applied research on aerodynamic characterization for flapping-wing propulsion for the flight regime of small Micro Aerial Vehicles ($Re \sim 10,000$). Specific challenges are the occurrence of highly unsteady flow features resulting from massive separation, wing-wing interaction and the high amount of wing flexibility.

PROGRESS

The work has two major fields of attention: 1) the study of generic aeroelastic phenomena relevant to MAV propulsion and 2) a more detailed characterization of the aerodynamic behavior of the flapping-wing DelFly MAV itself. A wind tunnel study was directed towards the characterization of the DelFly in both hover and forward flight configurations, using multiple-plane stereo-PIV. Secondly, flow visualizations in a water tank were performed to investigate the effect of transient vortex formation of low-aspect ratio wings (connected to the RTO AVT-202 work group). Further activities were undertaken to the simulation of 3D clap-and-fling wing interactions, comparing IBM and overset grid approaches.

DISSERTATIONS

-

SCIENTIFIC PUBLICATIONS

1. J.H.S. de Baar, M. Percin, R.P. Dwight, B.W. van Oudheusden, H. Bijl: Kriging regression of PIV data using a local error estimate, *Experiments in Fluids*, 2014; 55(1), 1650.
2. W.B. Tay, H. Bijl, B.W. van Oudheusden: Numerical simulation of X-wing type biplane flapping wings in 3D using the immersed boundary method, *Bioinspiration & Biomimetics*, vol.9, (2014) 036001.

3. S. Deng, M. Percin, B.W. van Oudheusden, B.D.W. Remes, H. Bijl: Experimental investigation of the aerodynamics of a bio-inspired flexible flapping-wing Micro Air Vehicle, *International Journal of Micro Air Vehicles*, 2014: 6(2), 105-115.
4. M. Percin, B.W. van Oudheusden, H.E. Eisma, B.D.W. Remes: Three-dimensional vortex wake structure of a flapping-wing micro aerial vehicle in forward flight configuration, *Experiments in Fluids*, 2014: 55: 1806.
5. J. Caetano, M. Percin, C. de Visser, B. van Oudheusden, G. de Croon, C. de Wagter, B. Remes, M. Mulder: Tethered vs. free flight force determination of the DelFly II flapping wing micro air vehicle, 2014 International Conference on Unmanned Aircraft Systems (ICUAS'14), May 27-30, 2014, Orlando, FL, USA.
6. S. Deng, M. Percin, B.W. van Oudheusden, B. Remes, H. Bijl: Force and flowfield measurements of a bio-inspired flapping MAV 'Delfly Micro', AIAA-2014-2564, 44th AIAA Fluid Dynamics Conference, 16-20 June 2014, Atlanta, GA, USA.
7. M. Percin, L. Ziegler, B.W. van Oudheusden: Flow around a suddenly accelerated rotating plate at low Reynolds number, 17th Int. Symposium on Applications of Laser Techniques to Fluid Mechanics, Lisbon, Portugal, 7-10 July, 2014.
8. T.A. Noyon, W.B. Tay, B.W. van Oudheusden, H. Bijl: Effect of chordwise deformation on unsteady aerodynamic mechanisms in hovering flapping flight, 2014 International Micro Air Vehicle Conference and Competition (IMAV 2014), 12-15 August 2014, Delft, The Netherlands, p.110-117.
9. A. Tenaglia, M. Percin, B.W. van Oudheusden, S. Deng, B. Remes: Vortex Formation and Force Generation Mechanisms of the DelFly II in Hovering Flight, 2014 International Micro Air Vehicle Conference and Competition (IMAV 2014), 12-15 August 2014, Delft, The Netherlands, pp.204-211.
10. T.A. Noyon, W.B. Tay, B.W. van Oudheusden, H. Bijl: Effect of chordwise deformation on unsteady aerodynamic mechanisms in hovering flapping flight, *International Journal of Micro Air Vehicles* 6 (4), pp. 265-277, 2014.

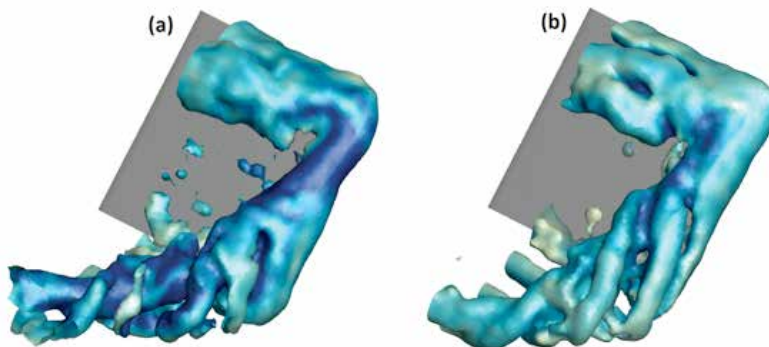

Vortex formation on a low-aspect ratio revolving flat plate at high angle of attack: (a) pitching and (b) translating motion (to be published in *Exp. Fluids*)

PROJECT LEADERS

FFJ Schrijer, F Scarano, BW van Oudheusden

RESEARCH THEME

Complex dynamics of fluids

PARTICIPANTS

Z Sun, R Giepmans, K Lynch, Q Ye, F Avallone

COOPERATIONS

ESA, VKI, DLR, NLR, ASTRIUM, TNO, ONERA, UNINA

FUNDED

| | |
|------------------------------|------|
| EU (TFAST), ESA (TRAV2), CSC | |
| University | 40 % |
| FOM | - |
| STW | - |
| NWO Other | - |
| Industry | - |
| TNO | - |
| GTI | - |
| EU | 35 % |
| Scholarships | 25 % |

START OF THE PROJECT

2003

INFORMATION

F Schrijer
015 278 6386
f.f.j.schrijer@tudelft.nl

PROJECT AIM

Development and implementation of non-intrusive measurement techniques for high-speed compressible flows with special focus on particle image velocimetry. The measurement techniques are subsequently used to investigate flow phenomena that are pertinent to launchers, high-speed air transport systems and reentry vehicles. Specific topics that are studied are shockwave boundary layer interaction and control, compressible boundary layer transition and compressible baseflows.

PROGRESS

- 1) Investigation of flow control by means of micro-ramps of shock wave boundary layer interactions
- 2) Study and control of transitional shock-wave boundary layer interactions (EU FP7 project TFAST)
- 3) Investigation of compressible and incompressible launcher baseflows using (TOMO) PIV and PIV based pressure integration.
- 4) Experimental investigation of (hypersonic) boundary layer transition using tomographic particle image velocimetry.

DISSERTATIONS

-

SCIENTIFIC PUBLICATIONS

1. Zhengzhong Sun, Fulvio Scarano, Bas W. van Oudheusden, Ferry J. J. Schrijer, Xiao Wang, Yonghua Yan, Chaoqun Liu: Numerical and experimental investigations of the supersonic microramp wake, *AIAA Journal*, 2014, Vol.52: 1518-1527.
2. Z. Sun, F. F. J. Schrijer, F. Scarano, B. W. van Oudheusden: Decay of the supersonic turbulent wakes from micro-ramps, *Physics of Fluids*, 26, 025115 (2014).
3. R.H.M. Giepmans, F.F.J. Schrijer and B.W. van Oudheusden: Flow control of an oblique shock wave reflection with micro-ramp vortex generators: effects of location and size, *Physics of Fluids*, *Phys. Fluids* 26, 066101 (2014).
4. Schrijer, F. F. J. and Sciacchitano, A. and Scarano, F. Spatio-temporal and modal analysis of unsteady fluctuations in a high-subsonic base flow, *Physics of Fluids*, 26, 086101 (2014).
5. Avallone F., Ye Q., Schrijer F.F.J., Scarano F. & Cardone G. 2014. Tomographic PIV investigation of roughness-induced transition in a hypersonic boundary layer. *Exp Fluids* 55:
6. R.H.M. Giepmans, F.F.J. Schrijer, B.W. van Oudheusden: High-resolution PIV measurements of a transitional shock wave - boundary layer interaction, *AIAA Aviation 2014*, AIAA-2014-3333, 16-20 June 2014, Atlanta, GA, USA.
7. R.H.M. Giepmans, K.P. Lynch, F.F.J. Schrijer, B.W. van Oudheusden: Investigation of a transitional oblique shock wave reflection using PIV, 17th Int. Symp. on Applications of Laser Techniques to Fluid Mechanics, Lisbon, Portugal, 7-10 July 2014.
8. R.H.M. Giepmans, F.F.J. Schrijer, B.W. van Oudheusden: Tracking a moving boundary layer transition front in supersonic flow using infrared thermography, 12th Int. Conf. Quantitative InfraRed Thermography, QIRT 2014, 7-11 July 2014, Bordeaux.
9. D. Szubert, W. van Veen, F. Grossi, Y. Hoarau, M. Braza, R. Giepmans, F. Schrijer, B. van Oudheusden: Physics and modelling of the transonic and supersonic shock wave boundary layer interaction of oblique and normal shock at high Reynolds number, *ETMM10*, 17-19 Sept. 2014, Marbella, Spain.

BAYESIAN ESTIMATES OF ERROR DUE TO RANS TURBULENCE MODELS

PROJECT AIM

To 1) quantify error introduced into RANS simulations by the turbulence closure model, and 2) devise predictive methods giving improved accuracy and adding uncertainty bounds. We investigate Bayesian approaches to take into account uncertainties in RANS turbulence models due to both uncertain closure coefficients, and uncertainty arising from the assumptions in their mathematical form. The first step consists of adapting and validating Bayesian theories, for uncertainty quantification of fundamental turbulent flows using a single turbulence model. Next, a general strategy for the quantification of modeling uncertainties will be proposed using Bayesian Model Averaging techniques, in which multiple turbulence models are combined in a single predictive scenario.

PROGRESS

We develop a stochastic, a posteriori error estimate, calibrated to specific classes of flow. It is based on variability in model closure coefficients across multiple flow scenarios, for multiple closure models. The variability is estimated using Bayesian calibration against experimental data for each scenario, and Bayesian Model-Scenario Averaging (BMSA) is used to collate the resulting posteriors, to obtain a stochastic estimate of a Quantity of Interest (QoI) in an unmeasured (prediction) scenario. The scenario probabilities in BMSA are chosen using a sensor which automatically weights those scenarios in the calibration set which are similar to the prediction scenario. The methodology is applied to the class of turbulent boundary-layers subject to various pressure gradients. For all considered prediction scenarios the standard-deviation of the stochastic estimate is consistent with the measurement ground truth. Furthermore, the mean of the estimate is more consistently accurate than the individual model predictions.

DISSERTATIONS

-

SCIENTIFIC PUBLICATIONS

1. W.N. Edeling, P. Cinnella, R.P. Dwight, H. Bijl, "Bayesian estimates of parameter variability in the $k-\epsilon$ turbulence model" *Journal of Computational Physics*, Volume 258, 2014.
2. W.N. Edeling, P. Cinnella, R.P. Dwight, "Predictive RANS simulations via Bayesian Model-Scenario Averaging" *Journal of Computational Physics*, Volume 275, 2014.
3. W.N. Edeling, R.P. Dwight, P. Cinnella, "Simplex-Stochastic Collocation Method For Higher Dimensional Uncertainty Quantification Problems", *Journal of Computational Physics*, Volume 278, 2014.

PROJECT LEADERS

R Dwight, P Cinnella

RESEARCH THEME

Mathematical and computational methods for fluid flow analysis

PARTICIPANTS

W Edeling, M Schmelzer, R Dwight, P Cinnella

COOPERATIONS

Arts et Métiers-ParisTech, Delft University of Technology, ONERA Office National d'Etudes et de Recherches Aérospatiales, Dassault

FUNDED

L'Agence National de le Recherche EU FP7 STRP UMRIDA (Uncertainty management in industrial applications)

| | |
|--------------|------|
| University | - |
| FOM | - |
| STW | - |
| NWO Other | - |
| Industry | 50 % |
| TNO | - |
| GTI | - |
| EU | 50 % |
| Scholarships | - |

START OF THE PROJECT

2011

INFORMATION

R Dwight

015 278 5773

R.P.Dwight@tudelft.nl

<https://aerodynamics.lr.tudelft.nl/~rdwight/>



Prof.dr.ir. AJHM Reniers



Prof.dr. JD Pietrzak



Prof.dr.ir. WSJ Uijtewaal

The Environmental Fluid Mechanics Group performs fundamental, process-oriented research on fluid flow problems of practical relevance in water management, environmental engineering, hydraulic engineering and coastal engineering. To enhance the potential of practical applications, the section not only aims at writing publications, as far as scientific output is concerned, but also at the production of software that is available via internet. Examples of software packages are SWAN (Simulating Waves Nearshore) and SWASH (Simulating Waves till Shore). Free surface flow models based upon unstructured grids are in preparation and will be released in coming years. Within this philosophy the research program encompasses the following main items:

- Free surface waves with topics such as: Generation and prediction of squall oscillations and harbour seiches, dynamics of surf beat and the wave models SWAN and SWASH.
- Shallow flows, transport and sedimentation with the following topics: turbulence and flow structures in rivers and its flood planes, stability and transport under waves and currents of rock elements in cover layers consisting of loose, granular material,
- Transport of suspended particulate matter with topics such as: advanced, experimental and numerical work concerning particle-turbulence interaction as well as flocculation and sedimentation processes
- Numerical model development with topics such as: development of the non-hydrostatic models for the investigation of dam breaks including inundations, short wave problems, near field plume discharges, stratified flows, and local scour near dams, unstructured grids via finite volume methods and finite element methods and development of large scale integrated 1d/2d rainstorm drainage/flooding model applicable to rural and urban areas.

PROJECT AIM

Present state of the art wave models are still insufficiently accurate regarding shallow water dissipation and non-linear interactions in the coastal zone. This project will focus on three main areas; improvement of modelling capabilities of physical processes in the coastal zone, procurement, utilisation and dissemination of high quality datasets and the development, testing and dissemination of new source terms for third generation wave models.

PROGRESS

A new source term formulation for depth-induced wave breaking has been developed, calibrated and verified over an extensive selection of laboratory and field cases. A study investigating the implications and dependencies of this new source term was also carried out with particular emphasis on extreme wave conditions (a 1:4000 year storm). An inconsistency in the implementation of the LTA source term for triads has also been addressed and alternative triad models considered. Qualitatively, these alternatives provide superior results at the high frequency end of the spectrum. Research is now focused on the implications of the inconsistency for 2D field cases. Preliminary investigations on the effect of both the new depth-induced breaking and triad source terms have also been carried out. Analysis of spectral evolution is being carried out by USACE and Shell IEP.

DISSERTATIONS

-

SCIENTIFIC PUBLICATIONS

1. Salmon, J.E., Holthuijsen, L.H., Smit, P.B., van Vledder, G.Ph. and Zijlema, M., 2014. Alternative source terms for SWAN in the coastal region, 34th Int. Conf. Coastal Engng., Coastal Engineering Research Council.

PROJECT LEADERS

G van Vledder, J Hanson,
LH Holthuijsen, K Ewans, J Pietrzak

RESEARCH THEME

Mathematical and computational
methods for fluid flow analysis

PARTICIPANTS

G van Vledder, J Hanson, LH
Holthuijsen, K Ewans

COOPERATIONS

Arcadis NL/Alkyon Hydraulic
Consultancy & Research, US
Army Corps of Engineers, Shell
International Exploration and
Production

FUNDED

Office of Naval Research, USA ,
Delft University of Technology, NL
University -
FOM -
STW -
NWO Other -
Industry 100 %
TNO -
GTI -
EU -
Scholarships -

START OF THE PROJECT

2010

INFORMATION

G Ph van Vledder
015 278 3255
g.p.vanvledder@tudelft.nl

SEDIMENT NOURISHMENT AS A SOLUTION TO AUTONOMOUS BED DEGRADATION OF THE RHINE RIVER : RESPONSE TO SEDIMENT OVERLOADING /

PROJECT LEADERS

WSJ Uijttewaal, A Blom

RESEARCH THEME

Complex dynamics of fluids

PARTICIPANTS

C Orrú

COOPERATIONS

-

FUNDED

Cornelis Lely Stichting

Regional Government of Sardinia

(Italy) (Regione Autonoma della

Sardegna-Programma Master&Back)

Delft University of Technology

University -

FOM -

STW -

NWO Other -

Industry 25 %

TNO -

GTI -

EU -

Scholarships 75 %

START OF THE PROJECT

2011

INFORMATION

C Orrú

015 278 9624

C.Orru@tudelft.nl

PROJECT AIM

The main goal is to provide insights on the development of the morphodynamic pattern of rivers with sand-gravel mixtures during unsteady conditions. More specifically we study the influence of a lack of sediment supply on the evolution of a sand-gravel reach. To this end we created a new experimental data set for validation of numerical models for sand-gravel morphodynamics. We focus on the processes involved in the bed degradation of mixed sediment. Previous development by the participant of an image analysis tool has enabled detailed data regarding the evolution of the grain size distribution of the bed surface with time.

PROGRESS

New equipment was developed to measure the time evolution of the grain size distribution of the bed surface in laboratory experiments over the entire flume using image analysis based on the technique presented by Orrú et al. (2014). A flume experiment was conducted using this equipment. A bed composed of a bimodal sediment mixture was installed with a uniform slope and an imposed gradual fining pattern. Initially, the sand fraction gradually increased in streamwise direction until the bed was fully composed of sand. Resulting from the imposed lack of sediment supply the bed developed towards a more abrupt transition in grain size and slope. We observed the formation of a static armour layer and bed degradation increasing in downstream direction. The data of the experiment were used in a simulation using a numerical gravel-sand model. The results of the flume experiment together with the model simulation will be presented in a scientific paper.

DISSERTATIONS

-

SCIENTIFIC PUBLICATIONS

1. Orrú, C., Chavarrias, V., Uijttewaal, W. S. J., and Blom, A. (2014). Image analysis for measuring the size stratification in sand-gravel laboratory experiments. *Earth Surface Dynamics*, 2(1):217-232.

SIMULATING WAVES TILL SHORE (SWASH) /

PROJECT AIM

The long term goal is the development of the SWASH (Simulating Waves till SHore) model for describing complex changes to rapidly varied flows and wave transformations in coastal waters, ports and harbors.

PROGRESS

As a starting point we have implemented sediment transport in SWASH. Only transport of non-cohesive sediment (e.g. sand) is modelled. Cohesive sediment is not taken into account. Also suspended load is modelled in SWASH, whereas bed load is not taken into account. Finally, it is assumed that the interaction between sediment and turbulent flow is mainly governed by sediment-induced buoyancy effects. The three-dimensional sediment transport processes include advection, diffusion, pickup and settling. A simple pickup function of Van Rijn (1984) is employed. This function models the amount of sediment eroded from the bed into the fluid, i.e. upward sediment flux, and is related to the bottom shear stress. The downward sediment flux depends on the settling velocity only. SWASH can be downloaded from <http://swash.sf.net>. There were about 1,600 downloads by the end of 2014 since the launch of SWASH at the website (as of February 9, 2011).

DISSERTATIONS

1. Pieter Bart Smit. Deterministic and stochastic modelling of ocean surface waves. PhD thesis, Delft University of Technology.

SCIENTIFIC PUBLICATIONS

1. Rijnsdorp, D.P., Smit, P.B., and Zijlema, M. (2014) Non-hydrostatic modelling of infragravity waves under laboratory conditions, *Coast. Engng.*, 85, 30-42.
2. Zijlema, M. (2014) Modelling vertical variation of turbulent flow across a surf zone using SWASH, in: P.J. Lynett (Eds.), *Proc. 34th Int. Conf. on Coast. Engng.*, published by the Coastal Engineering Research Council, paper no. waves.3.
3. Van Vledder, G. Ph. and Zijlema, M. (2014) Non-hydrostatic wave modelling in partly sheltered areas, in: P.J. Lynett (Eds.), *Proc. 34th Int. Conf. on Coast. Engng.*, published by the Coastal Engineering Research Council, paper no. waves.11.
4. Suzuki, T., Altomare, C., Verwaest, T., Trouw, K. and Zijlema, M. (2014) Two-dimensional wave overtopping calculation over a dike in shallow foreshore by SWASH, in: P.J. Lynett (Eds.), *Proc. 34th Int. Conf. on Coast. Engng.*, published by the Coastal Engineering Research Council, paper no. structures.3.
5. Van den Bos, J., Verhagen, H.J., Zijlema, M. and Mellink, B. (2014) Towards a practical application of numerical models to predict wave-structure interaction: an initial validation, in: P.J. Lynett (Eds.), *Proc. 34th Int. Conf. on Coast. Engng.*, published by the Coastal Engineering Research Council, paper no. structures.50.

PROJECT LEADERS

M Zijlema, A Reniers

RESEARCH THEME

Mathematical and computational methods for fluid flow analysis

PARTICIPANTS

DP Rijnsdorp, P Smit, G van Vledder

COOPERATIONS

-

FUNDED

| | |
|--------------|-------|
| University | 100 % |
| FOM | - |
| STW | - |
| NWO Other | - |
| Industry | - |
| TNO | - |
| GTI | - |
| EU | - |
| Scholarships | - |

START OF THE PROJECT

2010

INFORMATION

M Zijlema

015 278 3255

m.zijlema@tudelft.nl

<http://swash.sf.net>

PROJECT LEADERS

JD Pietrzak

RESEARCH THEME

Mathematical and computational methods for fluid flow analysis

PARTICIPANTS

O Kleptsova, JD Pietrzak

COOPERATIONS

-

FUNDED

| | |
|--------------|-------|
| University | 100 % |
| FOM | - |
| STW | - |
| NWO Other | - |
| Industry | - |
| TNO | - |
| GTI | - |
| EU | - |
| Scholarships | - |

START OF THE PROJECT

2014

INFORMATION

O Kleptsova

O.Kleptsova@TUDelft.nl

PROJECT AIM

The project aim is to gain a deeper insight in the flow dynamics of Baffin Bay. To achieve this goal a high-resolution flow model which includes such phenomena as stratification, topographic steering, wind forcing, tides, waves, currents and ice is to be developed. The model is to be validated against available data.

PROGRESS

As a first step a high resolution tidal model of Baffin Bay is set up using ADCIRC unstructured finite element model. The tidal model is able to correctly reproduce the essential characteristics of the 8 major tidal constituents. The model results are compared with the available tide gauge data.

DISSERTATIONS

-

SCIENTIFIC PUBLICATIONS

-

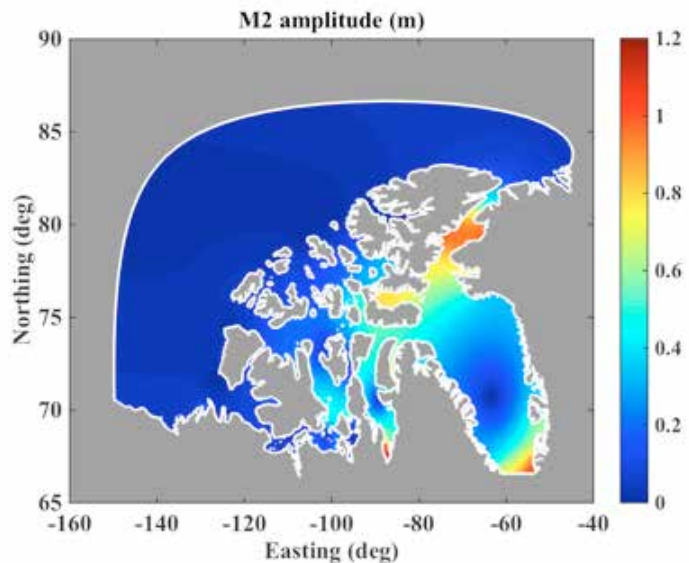

SUSTAINABLE ENGINEERING OF COASTAL SYSTEMS IN REGIONS OF FRESHWATER INFLUENCE /

PROJECT AIM

The overall project consists of two subprojects. This subproject will focus on the interaction of stratification, turbulence and SPM within the Rhine Region of Freshwater Influence. The aim is to gain more insight into the complex phenomena in front of the Dutch coastal zone, such as the transport and dispersion of the freshwater and SPM, the hindered mixing by stratification, effect of tidal straining on the evolution of fronts. The role of turbulence in stratified flows plays a key role. In addition, high quality turbulence data will be used to improve turbulence models.

PROGRESS

In September and October 2014 a field campaign is implemented off the Dutch coast near the Sand Engine. Three frames and two moorings with different instruments are deployed at two different locations, at the 12m and 18m depth contours. The campaign lasted for six weeks. The campaign was in collaboration with the National Oceanographic Centre and the University of Washington. A large dataset with e.g. salinity, temperature, velocities, turbidity and buoyancy fluxes is obtained. A preliminary data processing on a part of the dataset has been done. The conductivity and temperature sensors of the moorings and the ADCP data from the frames are processed and preliminary results are obtained.

DISSERTATIONS

-

SCIENTIFIC PUBLICATIONS

-

PROJECT LEADERS

JD Pietrzak, HJH Clercx

RESEARCH THEME

Complex dynamics of fluids

PARTICIPANTS

S Rijnsburger

COOPERATIONS

Eindhoven University of Technology

National Oceanography Centre

University of Washington, Deltares

FUNDED

STW

University -

FOM -

STW 100 %

NWO Other -

Industry -

TNO -

GTI -

EU -

Scholarships -

START OF THE PROJECT

2014

INFORMATION

S Rijnsburger

06 16385733

s.rijnsburger@tudelft.nl

PROJECT LEADERS

A Blom, WSJ Uijttewaal

RESEARCH THEME

Mathematical and computational methods for fluid flow analysis

PARTICIPANTS

ECMM Arkesteijn

COOPERATIONS

RWS, Twente University

FUNDED

STW

University -

FOM -

STW 70 %

NWO Other -

Industry 30 %

TNO -

GTI -

EU -

Scholarships -

START OF THE PROJECT

2014

INFORMATION

L Arkesteijn

015 278 9111

e.c.m.arkesteijn@tudelft.nl

PROJECT AIM

The main objective of this project is to develop a 2D numerical research code for flow and mixed size sediment transport to predict long term morphodynamic behavior and channel response to sediment management measures in lowland rivers. During the development of this code we will focus on using efficient techniques to make long term (1000 years) computations in 2D. In 2016 Rijkswaterstaat will start a sediment augmentation pilot in the Dutch Rhine. This pilot study will be analyzed and used as validation for the numerical model. Specific attention will be paid to the behavior of the bed elevation profile near bifurcation points, e.g. the Rhine bifurcation Pannerden.

PROGRESS

The project was started at December 1st. So far literature has been studied and a project work plan is being written.

DISSERTATIONS

-

SCIENTIFIC PUBLICATIONS

-

A STUDY ON WAVE-INDUCED RESPONSES OF MOORED FLOATING BODIES EMBEDDED IN A LARGE SCALE WAVE MODEL /

PROJECT AIM

An accurate prediction of the response of a vessel, moored in a harbor or coastal region, to the local wave climate (a composite of short and infragravity waves) is of great importance for safe operations of the vessel (e.g. loading and offloading activities). The overall aim of this study is to develop a numerical model system that resolves the wave propagation from deep to shallow water, and that is capable of predicting the (infragravity) wave-induced loads and motions of a vessel moored in a harbor or coastal region. For this purpose a floating body will be schematized in SWASH, a phase resolving numerical wave-flow model recently developed at the TU Delft.

PROGRESS

As infragravity waves play a key role in the wave-induced response of moored vessels, the capabilities of SWASH in reproducing the nearshore transformation of infragravity waves under laboratory and field conditions have been assessed. Furthermore, a non-moving body has been schematized in SWASH. At present effort is made to assess the capabilities of the extended model in predicting the wave-induced loads on a fixed vessel, and to extend the model by including motions of a moored vessel.

DISSERTATIONS

-

SCIENTIFIC PUBLICATIONS

1. Rijnsdorp, D. P., Smit, P. B., & Zijlema, M. (2014). Non-hydrostatic modelling of infragravity waves under laboratory conditions. *Coastal Engineering*, 85, 30–42.

PROJECT LEADERS

JD Pietrzak, M Zijlema

RESEARCH THEME

Mathematical and computational methods for fluid flow analysis

PARTICIPANTS

DP Rijnsdorp

COOPERATIONS

Sichuan University, Chengdu, China

FUNDED

| | |
|--------------|-------|
| NWO | |
| University | - |
| FOM | - |
| STW | - |
| NWO Other | 100 % |
| Industry | - |
| TNO | - |
| GTI | - |
| EU | - |
| Scholarships | - |

START OF THE PROJECT

2011

INFORMATION

DP Rijnsdorp

d.p.rijnsdorp-1@tudelft.nl

PROJECT LEADERS

C Chassagne, JC Winterwerp

RESEARCH THEME

Complex structures of fluids

PARTICIPANTS

M Ibanez

COOPERATIONS

-

FUNDED

Deltares, CEAMaS

University 25 %

FOM -

STW -

NWO Other -

Industry 75 %

TNO -

GTI -

EU -

Scholarships -

START OF THE PROJECT

2011

INFORMATION

ME Ibanez

015 278 4070

M.E.IbanezSanz-16@tudelft.nl

PROJECT AIM

The aim of this project is to study and understand the contribution of colloidal science to the civil engineering discipline. The purpose of this research proposal is to improve our understanding of the cohesive sediments through an integrated analysis of the processes of coagulation, flocculation, settling, and consolidation. This analysis is based on the study of the colloidal interaction of clay and non-clay minerals characterized by the zeta potential, which measures the surface charge of the clay and non-clay minerals.

PROGRESS

During the last year, coagulation and flocculation experiments as function of zeta potential and shear stresses were done. One article about flocculation and the effect on the surface charge of the clay particles (cohesive sediments) is almost finished. The settling process of cohesive sediments and a systematic study of the settling experiments were also done. A second article about the study of settling process is being written now.

The study of consolidation and rheology through the flocculation and zeta potential will be investigated during this year.

DISSERTATIONS

-

SCIENTIFIC PUBLICATIONS

1. The role of mono- and divalent ions in the stability of kaolinite suspensions and fine tailings. Ibanez, M., Chassagne, C., Wijdelveld, A. Clays and Clay Minerals, Vol. 62, No. 5, 374–385, 2014.

EVOLUTION OF CLAY FLOC SIZES AS FUNCTION OF POLYMER TYPE, DOSAGE AND SHEAR STRESSES /

PROJECT AIM

The aim is to link the physical properties of cohesive sediment to its chemical characteristics. In order to assess these properties the following measurements are performed: electrokinetic characterization of the surface charge, viscosity measurements, particle size distribution in time. Models are subsequently developed to link all these properties..

PROGRESS

The experiments regarding the floc size distribution as function of time, shear, polymer dose, etc... and the settling velocity of suspensions in settling columns, varying polymer dose, clay concentration and mixing methods are done. Two articles are in preparation about these topics. The theory for electroacoustic characterization of slurries has led to 2 publications (one published, one under review).

DISSERTATIONS

-

SCIENTIFIC PUBLICATIONS

1. Reciprocal relations in electroacoustics; C. Chassagne and D. Bedeaux; JOURNAL OF CHEMICAL PHYSICS; Volume: 141; Issue: 4.
2. Hydrodynamic size and electrophoretic mobility of latex nanospheres in monovalent and divalent electrolytes; Chassagne, C.; Ibanez, M.; COLLOIDS AND SURFACES A-PHYSCOCHEMICAL AND ENGINEERING ASPECTS Volume: 440 Special Issue: SI Pages: 208-216.

PROJECT LEADERS

C Chassagne

RESEARCH THEME

Complex structures of fluids

PARTICIPANTS

M Ibanez, C Chassagne

COOPERATIONS

PECSA, Université Paris-Sorbonne, Cordouan Tech., Deltares

FUNDED

Deltares, Allocation Nationale de Recherche (ANR)

| | |
|--------------|------|
| University | 50 % |
| FOM | - |
| STW | - |
| NWO Other | - |
| Industry | 50 % |
| TNO | - |
| GTI | - |
| EU | - |
| Scholarships | - |

START OF THE PROJECT

2011

INFORMATION

C Chassagne
c.chassagne@tudelft.nl
www.citg.tudelft.nl/index.php?id=72915

PROJECT LEADERS

GS Stelling, JD Pietrzak, BC van Prooijen

RESEARCH THEME

Mathematical and computational methods for fluid flow analysis

PARTICIPANTS

ND Volp

COOPERATIONS

Deltares, Rijkswaterstaat, BAW, Bundeswehr Universität München

FUNDED

| | |
|---|-------|
| Building with Nature, Ecoshape University | - |
| FOM | - |
| STW | - |
| NWO Other | - |
| Industry | 100 % |
| TNO | - |
| GTI | - |
| EU | - |
| Scholarships | - |

START OF THE PROJECT

2009

INFORMATION

ND Volp
015 278 4069
n.d.volp@tudelft.nl

PROJECT AIM

The objective of the project is to improve the morphodynamic modelling of inter-tidal areas, focusing on model improvement and better model usage. Morphodynamic and hydrodynamic processes are strongly coupled and cover a wide range of time and length scales. Therefore, a multiple-scale approach is required. Typical challenges in model improvement are dealing with the wetting and drying of shallow areas, the coupling between the hydrodynamics and morphodynamics on the different time and length scales and the lack of accuracy of more coarse and efficient models.

PROGRESS

The subgrid method of Casulli, 2009 uses small scale bathymetry information for simulations on a coarser grid. Based on a similar approach, a depth-averaged shallow water model is derived, that accounts for small scale bathymetry and roughness variations. (Volp, 2014) The hydrodynamic results show a significant increase in accuracy, with only a slight increase in computational cost. We introduced a multiple grid approach to compute the morphodynamic evolution. The subgrid-based hydrodynamic model is coupled to a high resolution morphodynamic model. This gives a strong increase in accuracy of the morphodynamic solution (Volp, 2015 in review). The multiple grid approach is extended with a method that also accounts for suspended sediment dynamics. Similar to the approach for the hydrodynamics, small scale effects are taken into account to determine the sediment concentration and the net erosion and deposition.

DISSERTATIONS

-

SCIENTIFIC PUBLICATIONS

-

ACCOUNTING FOR SEDIMENT SORTING IN MODELLING SEDIMENT MANAGEMENT MEASURES /

PROJECT AIM

In order to predict the morphodynamic effects of sediment management measures (e.g. Figure 1), models are used to characterize the physical processes occurring in a river. The aim of this project is to improve modelling of sediment management measures. We will focus on (1) restoration of hyperbolicity of the set of conservation equations in mixed sediment modelling, (2) accounting for dune sorting (i.e., lee face sorting and the dune-covered mobile armour) and dune geometry in mixed sediment modelling, and (3) modelling the effects of dredging and sediment augmentation measures.

PROGRESS

We are evaluating the loss of hyperbolicity of the different state-of-the-art models dealing at field scale. An ellipticity check tool has been developed. With this method we check if the present approach to model sediment management measures is hyperbolic or, on the contrary, elliptic (and thus ill-posed). In order to gain insight into the physical processes that the active layer theory does not describe when a bed degrades into a finer substrate, flume experiments are being prepared for resembling this situation.

DISSERTATIONS

-

SCIENTIFIC PUBLICATIONS

-

PROJECT LEADERS

A Blom, WSJ Uijttewaal

RESEARCH THEME

Complex dynamics of fluids

PARTICIPANTS

V Chavarrias

COOPERATIONS

RWS, Utrecht U, Twente U

FUNDED

STW

University -

FOM -

STW 70 %

NWO Other -

Industry 30 %

TNO -

GTI -

EU -

Scholarships -

START OF THE PROJECT

2014

INFORMATION

V Chavarrias

015 278 9111

vchavarriasborras@tudelft.nl

Sediment nourishment in the Rhine



GEOSCIENCE & REMOTE SENSING



Prof.dr.ir. HJJ Jonker



Prof.dr.ir. AP Siebesma

This group studies an entirely new research field using existing expertise in fluid mechanics and turbulence at TU Delft to address important questions in the field of weather and climate. Special attention is paid to the role of clouds, of which relatively little is known. It is believed that clouds could have a considerable impact on the size of the estimated enhanced greenhouse effect.

HIGH RESOLUTION MODELING OF DEEP CUMULUS CONVECTION

PROJECT AIM

A realistic representation of deep cumulus clouds remains one of the most challenging problems in atmospheric modeling. Numerical Weather Prediction and climate models, in which deep convection is parametrized, tend to predict the onset of deep convection too early during the day. We will investigate the transition from shallow clouds to deep convection using the Dutch Atmospheric Large Eddy Simulation (DALES) model. The simulation results of DALES will be used to determine the relative roles of gradual moistening of the cloud layer and the organization of the boundary layer below cloud base.

PROGRESS

Project has been finished. The thesis, entitled "The interaction between deep convective clouds and their environment" has been defended successfully on January 2014.

DISSERTATIONS

1. The interaction between deep convective clouds and their environment. January 14, S Böing.

SCIENTIFIC PUBLICATIONS

1. Dorrestijn, J. Crommelin, D.T., Biello, J., Boing, S. 2013 A data-driven stochastic multi-cloud model for stochastic parameterization of deep convection. Phil. Trans. R. Soc. A., 371, 20120 374.

PROJECT LEADERS

HJJ Jonker, AP Siebesma

RESEARCH THEME

Complex dynamics of fluids

PARTICIPANTS

SJ Böing, HJJ Jonker, AP Siebesma,
SR de Roode

COOPERATIONS

KNMI, Dr. W.Grabowski (NCAR,
Boulder, Colorado, U.S.A)

FUNDED

| | |
|--------------|-------|
| TU Delft | |
| University | 100 % |
| FOM | - |
| STW | - |
| NWO Other | - |
| Industry | - |
| TNO | - |
| GTI | - |
| EU | - |
| Scholarships | - |

START OF THE PROJECT

2009

INFORMATION

S Böing
015 278 3478
s.j.boing@tudelft.nl
www.grs.citg.tudelft.nl

CLOUD-CLIMATE FEEDBACK: THE ROLE OF BOUNDARY LAYER CLOUDS

PROJECT LEADERS

SR de Roode, AP Siebesma

RESEARCH THEME

Complex dynamics of fluids

PARTICIPANTS

J van der Dussen, SR de Roode, AP Siebesma

COOPERATIONS

KNMI, + 12 other EU partners involved in EUCLIPSE

FUNDED

| | |
|--------------|-------|
| EU | |
| University | - |
| FOM | - |
| STW | - |
| NWO Other | - |
| Industry | - |
| TNO | - |
| GTI | - |
| EU | 100 % |
| Scholarships | - |

START OF THE PROJECT

2010

INFORMATION

J van der Dussen
015 278 4720
J.J.vanderDussen@tudelft.nl
www.grs.citg.tudelft.nl

PROJECT AIM

The cloud response due to the enhanced greenhouse effect remains the largest source of uncertainty in climate model projections of a future climate. The EU-funded Cloud Intercomparison, Process Study & Evaluation Project (EUCLIPSE) aims to reduce the uncertainty in the representation of cloud processes and feedbacks in the new generation of Earth System Models (ESMs). This sub-project will use the Dutch Atmospheric Large-Eddy Simulation model to study in detail turbulent flows in cloudy atmospheres. Central question is how the vertical atmospheric stability controls the spatial coverage and depth of low clouds like stratocumulus and shallow cumulus.

PROGRESS

Project has been finished. The thesis will be defended on June 22, 2015.

DISSERTATIONS

-

SCIENTIFIC PUBLICATIONS

1. J. J. van der Dussen, S. R. de Roode, and A. P. Siebesma, 2014: Factors Controlling Rapid Stratocumulus Cloud Thinning. *J. Atmos. Sci.*, 71, 655–664.

DROPLET-TURBULENCE DYNAMICS UNDER HETEROGENEOUS CONDITIONS

PROJECT AIM

The focus will be on the evolution of droplet size distributions under a sharp gradient in the mean gas velocity, the droplet concentration and the background humidity. The goal of this project is to understand the interplay between the turbulence dynamics, and the droplet distribution. The two key questions to be addressed are: What is the influence of shear in the mixing layer on the droplet distribution and dispersion, droplet collisions and coalescence efficiency. How are the dispersion, collision frequency and coalescence efficiency influenced by the orientation of the mixing layer with respect to gravity?

PROGRESS

Three manuscripts have been written and have been submitted for review. The project has been finished. The thesis will be defended on June 19, 2015.

DISSERTATIONS

-

SCIENTIFIC PUBLICATIONS

1. Perrin, Vincent E. and Jonker, Harm J. J. (2014) Preferred location of droplet collisions in turbulent flows. Phys. Rev. E, 89,033005.

PROJECT LEADERS

HJJ Jonker

RESEARCH THEME

Complex dynamics of fluids

PARTICIPANTS

V Perrin, HJJ Jonker

COOPERATIONS

Prof W. vd Water (TUE)

Humberto Bocanegra Evans (TUE)

FUNDED

FOM

University -

FOM 100 %

STW -

NWO Other -

Industry -

TNO -

GTI -

EU -

Scholarships -

START OF THE PROJECT

2010

INFORMATION

V Perrin

015 278 9174

v.e.perrin@tudelft.nl

www.grs.cityg.tudelft.nl

PREDICTIVE LARGE-EDDY-SIMULATIONS: IMPROVING CLOUD AND PRECIPITATION FORECASTING

PROJECT LEADERS

HJJ Jonker, AP Siebesma

RESEARCH THEME

Complex dynamics of fluids

PARTICIPANTS

J Schalkwijk, HJJ Jonker,
AP Siebesma, RAJ Neggers

COOPERATIONS

KNMI

FUNDED

TUD, KNMI

University 50 %

FOM -

STW -

NWO Other -

Industry 50 %

TNO -

GTI -

EU -

Scholarships -

START OF THE PROJECT

2010

INFORMATION

J Schalkwijk

015 278 9174

J.Schalkwijk@tudelft.nl

www.grs.citg.tudelft.nl

PROJECT AIM

Current weather and climate models do not have sufficient resolution to explicitly resolve low cloud evolution, and therefore use statistical models for this purpose. This program aims to improve prediction accuracy by using Large Eddy Simulations (LES) to perform the needed high-resolution calculations and integrate this in large-scale prediction models. Excessive computational requirements always forced reasonable domain LES to run on supercomputing facilities, whose batch queuing protocols inhibit interaction. This program aims to solve this using Graphical Processing Units (GPUs) to provide the necessary computational power.

PROGRESS

Two papers have been written, which are currently in press: J. Schalkwijk, H.J.J. Jonker, A.P. Siebesma, F. Bosveld. A Year-Long Large-Eddy Simulation of the Weather over Cabauw: an Overview. 2015. Monthly Weather Review. J. Schalkwijk, H.J.J. Jonker, A.P. Siebesma, E. van Meijgaard. Weather Forecasting using GPU-based Large-Eddy Simulations. 2015. Bulletin of the American Meteorological Society. The thesis will be defended on April 21, 2015.

DISSERTATIONS

-

SCIENTIFIC PUBLICATIONS

1. Stephan R. De Roode, A. Pier Siebesma, Sara Dal Gesso, Harm J. J. Jonker, Jérôme Schalkwijk and Jasper Sival, A mixed-layer model study of the stratocumulus response to changes in large-scale conditions. JAMES. Volume 6, Issue 4, December 2014, Pages: 1256–1270.

PROJECT AIM

The aim of this project is to simulate climate adaptation in neighbourhoods and districts of cities, with a main emphasis on heat. Issues like temperature effects and surface heat balances for building facades are taken into account. The model is coupled to a meso-scale model for large scale effects of the urban heat island effect.

PROGRESS

Two manuscripts have been written and submitted for review. The project has been finished. The thesis will be defended end of 2015.

DISSERTATIONS

-

SCIENTIFIC PUBLICATIONS

1. PJC Schrijvers, HJJ Jonker, S Kenjeres, SR de Roode; Breakdown of the night time urban heat island budget. Building and Environment, 83, 50–64.

PROJECT LEADERS

HJJ Jonker, S Kenjeres,
SR de Roode

RESEARCH THEME

Complex dynamics of fluids

PARTICIPANTS

PJC Schrijvers, S Kenjeres,
SR de Roode, HJJ Jonker

COOPERATIONS

WUR, TNO

FUNDED

| | |
|---------------------|-------|
| Kennis voor Klimaat | |
| University | - |
| FOM | - |
| STW | - |
| NWO Other | - |
| Industry | 100 % |
| TNO | - |
| GTI | - |
| EU | - |
| Scholarships | - |

START OF THE PROJECT

2010

INFORMATION

P Schrijvers
015 278 9174
P.J.C.Schrijvers@tudelft.nl
www.grs.citg.tudelft.nl

PROJECT LEADERS

D Crommelin (CWI), AP Siebesma,
HJJ Jonker

RESEARCH THEME

Complex dynamics of fluids

PARTICIPANTS

J Dorrestijn, D Crommelin (CWI),
F Selten (KNMI) AP Siebesma,
HJJ Jonker

COOPERATIONS

CWI, KNMI

FUNDED

| | |
|--------------|-------|
| NWO/ALW | |
| University | - |
| FOM | - |
| STW | - |
| NWO Other | 100 % |
| Industry | - |
| TNO | - |
| GTI | - |
| EU | - |
| Scholarships | - |

START OF THE PROJECT

2010

INFORMATION

HJJ Jonker
015 278 6157
H.J.J.Jonker@tudelft.nl
www.grs.citg.tudelft.nl

PROJECT AIM

Stochastic parameterization is an exciting new topic at the intersection of applied mathematics and climate science. In this project we will develop a stochastic approach to convection parameterization, combining new mathematical ideas on hybrid stochastic-deterministic models and multiscale systems with results from Large Eddy Simulation (LES) of atmospheric moist convection. The overall goal is to formulate a stochastic parameterization scheme that is suitable for practical use in climate models, and to evaluate the impact of such a scheme on cloud-climate feedbacks.

PROGRESS

A paper has been written about the usage of radar-data from Darwin in Australia, to construct a similar stochastic parameterization of deep convection. It is currently in press (Jesse Dorrestijn, Daan T. Crommelin, A. Pier Siebesma, Harm J.J. Jonker, and Christan Jakob. 2015 Stochastic parameterization of convective area fractions with a multcloud model inferred from observational data. Journal of the Atmospheric Sciences). Further, we are testing this parameterization of deep convection in a simplified climate model called SPEEDY. Such a model can be executed at a laptop such that it is easy to test the performance of the new parameterization. The impact of this implementation in this climate model has been analysed and a manuscript has been written. The project has been finished. The thesis will be defended second half of 2015.

DISSERTATIONS

-

SCIENTIFIC PUBLICATIONS

-

LOCAL PRECIPITATION EXTREMES DERIVED FROM NON-HYDROSTATIC MODELING

PROJECT AIM

Events of extreme precipitation are associated with flooding, erosion, and water damage and may impact transport and safety. It is commonly expected that precipitation extremes will increase as the climate warms, as a warmer atmosphere has a larger capacity for moisture. With this study, we aim to increase the understanding of underlying causes of extreme precipitation, as well as anticipate how events of extreme precipitation will react to a warming climate. To this end, observational data, as well as Large Eddy Simulations (LES) are used. Furthermore, we will explore local precipitation extremes over the Netherlands within HARMONIE, a non-hydrostatic high resolution model.

PROGRESS

Using KNMI precipitation data, the dependence of extreme precipitation to temperature and humidity has been analyzed. These results have been further assessed using a conceptual 1D model. This work is presented in "Understanding convective extreme precipitation scaling using observations and an updraft model", which has been published in the Journal of Atmospheric Sciences. We are currently in the process of using hindcasts to better understand the large scale forcings associated with extreme events. These results will be used in LES to further develop our understanding of earlier findings.

DISSERTATIONS

-

SCIENTIFIC PUBLICATIONS

1. Attema, J.J., J.M. Loriaux and G. Lenderink, Extreme precipitation response to climate perturbations in an atmospheric mesoscale model Environmental Research Letters, 2014, 9, 14003, doi:10.1088/1748-9326/9/1/014003.

PROJECT LEADERS

AP Siebesma

RESEARCH THEME

Complex dynamics of fluids

PARTICIPANTS

J Loriaux, AP Siebesma,

G Lenderink, SR de Roode

COOPERATIONS

KNMI

FUNDED

Knowledge for Climate

University -

FOM -

STW -

NWO Other -

Industry 100 %

TNO -

GTI -

EU -

Scholarships -

START OF THE PROJECT

2011

INFORMATION

J Loriaux

030 220 6376

j.m.loriaux@tudelft.nl

www.grs.citg.tudelft.nl

PROJECT LEADERS

SR de Roode, AP Siebesma

RESEARCH THEME

Complex dynamics of fluids

PARTICIPANTS

S dal Gesso, SR de Roode,
AP Siebesma

COOPERATIONS

KNMI, + 12 other EU partners
involved in EUCLIPSE

FUNDED

| | |
|--------------|-------|
| EU | |
| University | - |
| FOM | - |
| STW | - |
| NWO Other | - |
| Industry | - |
| TNO | - |
| GTI | - |
| EU | 100 % |
| Scholarships | - |

START OF THE PROJECT

2010

INFORMATION

S de Roode
S.R.deRoode@tudelft.nl
www.grs.citg.tudelft.nl/

PROJECT AIM

The cloud response due to the enhanced greenhouse effect remains the largest source of uncertainty in climate model projections of a future climate. The EU-funded Cloud Intercomparison, Process Study & Evaluation Project (EUCLIPSE) aims to reduce the uncertainty in the representation of cloud processes and feedbacks in the new generation of Earth System Models (ESMs). This sub-project will use the Dutch Atmospheric Large-Eddy Simulation model to study in detail turbulent flows in cloudy atmospheres. Central question is how the vertical atmospheric stability controls the spatial coverage and depth of low clouds like stratocumulus and shallow cumulus.

PROGRESS

Project has been finished. The thesis has been defended on March 18, 2015.

DISSERTATIONS

-

SCIENTIFIC PUBLICATIONS

1. Dal Gesso, S. D., Siebesma, A. P., de Roode, S. R. and van Wessem, J. M. (2014), A mixed-layer model perspective on stratocumulus steady states in a perturbed climate. *Q.J.R. Meteorol. Soc.*, 140: 2119–2131. doi: 10.1002/qj.2282.
2. Dal Gesso, S., Siebesma, A. P. and de Roode, S. R. (2014), Evaluation of low-cloud climate feedback through single-column model equilibrium states. *Q.J.R. Meteorol. Soc.* doi: 10.1002/qj.2398.
3. Stephan R. De Roode, A. Pier Siebesma, Sara Dal Gesso, Harm J. J. Jonker, Jérôme Schalkwijk and Jasper Sival, A mixed-layer model study of the stratocumulus response to changes in large-scale conditions. *JAMES*. Volume 6, Issue 4, December 2014, Pages: 1256–1270.



Prof.dr.ir. AA Darhuber



Prof.dr.ir. J Snoeijer

In 2006 prof. M.E.H. (Rini) van Dongen retired as head of the research group Gas Dynamics and obtained emeritus status. In 2007 prof. Anton Darhuber was appointed as his successor. Prof. A. (Mico) Hirschberg was interim leader of the group Gas Dynamics in 2006 and 2007. On January 1, 2008 the research group Gas Dynamics was officially renamed into Mesoscopic Transport Phenomena (MTP). On January 1, 2009 the head of the group Low-Temperature Physics (LTE) prof. A.T.A.M. (Fons) de Waele retired and LTE became a part of MTP. Therefore, currently three major lines of research coexist in MTP: the first corresponds to the activities of the former group Gas Dynamics, i.e. research on aero-acoustics and condensation phenomena; the second involves fluid dynamics at small lengthscales, where interfacial typically dominate over inertial effects. The third corresponds to the activities of the former group Low-Temperature Physics, i.e. research on thermo-acoustics.

In September 2008, prof. Federico Toschi was appointed professor in the Department of Applied Physics and became a member of MTP. He is working in the field of statistical physics, fluid dynamical turbulence and micro-/nanofluidics. In February 2009, Jens Harting was appointed Assistant Professor in the group MTP. His expertise rests with large-scale Lattice Boltzmann simulations of suspension dynamics as well as micro- and meso-scale flows.

The research activities related to gas dynamics concern the study of wave phenomena in gases. Aero-acoustics is the study of the interaction between sound and flows. The research concerns the study of wave generation by elementary processes in flows, with the focus on confined flows and sound generation by vortices. This work has many important industrial applications. Condensation phenomena are studied using gas-dynamical devices such as expansion wave tubes to obtain fundamental information about the physics of nucleation and droplet growth in complex gas mixtures. This involves the development of models for the properties of molecular clusters in the nanometer range at extreme conditions far below the freezing point, for which bulk liquid properties are unknown.

Research in the area of micro- and nano-fluidics comprises both fundamental and application-inspired topics ranging from fluid physics at nano-scales to manufacturing processes of optoelectronic devices. Current and commencing projects concern dip- and die-coating of chemically patterned substrates, flows driven by temperature and concentration gradients, as well as flows involving phase changes.

Research activities of the former group LTE concern pulse-tube refrigeration, thermoacoustics, and vortex cooling. These topics have a common thermodynamic and hydrodynamic background. They provide cooling without moving parts in the cold regions of the system. All topics address new physical questions in gas dynamics with the aim of unraveling basic working principles.

TOWARDS GREEN INKS (TGINK)

PROJECT AIM

Inkjet inks are cheap, ecological and versatile, with potential for improvement. To further improve inkjet inks the agglomeration depth of the colorant particles and the relevant effects have to be understood. The goal of this project is to understand the relevant parameters and their effects on the agglomeration depth of colorant particles. We do so using a hybrid code of Lattice Boltzmann and Molecular Dynamic simulations.

PROGRESS

We have extended a hybrid Lattice Boltzmann and Molecular Dynamics code that incorporates most of the relevant effects: Multiple fluid components, suspended particles, thermal fluctuations, locally varying wettabilities on porous substrates and evaporation. This code will be applied to the research topic in the coming year.

DISSERTATIONS

-

SCIENTIFIC PUBLICATIONS

-

PROJECTLEADERS

J Harting

RESEARCHTHEME

Complex dynamics of fluids

PARTICIPANTS

Dennis Hessling, Kees Kuijpers

COOPERATIONS

Océ

FUNDED

| | |
|--------------|-------|
| M2i | |
| University | - |
| FOM | - |
| STW | - |
| NWO Other | 100 % |
| Industry | - |
| TNO | - |
| GTI | - |
| EU | - |
| Scholarships | - |

START OF THE PROJECT

2013

INFORMATION

D Hessling

06 42557767

d.m.hessling@tue.nl

www.tue.nl/en/university/

departments/applied-physics/

the-department/staff/detail/ep/e/d/

ep-uid/20097255/ep-tab/4/

FLOW-INDUCED PULSATIONS IN GAS TRANSPORT SYSTEMS: PREDICTION, PREVENTION AND INFLUENCE ON VOLUME FLOW MEASUREMENTS

PROJECT LEADERS

AA Darhuber

RESEARCH THEME

Complex dynamics of fluids

PARTICIPANTS

A Hirschberg, G Nakiboglu,
O Rudenko, HWM Hoeijmakers
(UTwente), J. Haas, X. Pelorson
(Gipsa), P.M.G. Hoeijmakers
(TU/e), B. Lemoine, L. Le Marrec
(Rennes), C. Kameni Djumo,
Ph. Bequin, J-P. Dalmont, J. Gilbert
(Le Mans), J. Golliard, S. Belfroid
(TNO), H. Riezebos (DNV-Kema)

COOPERATIONS

DNV-Kema, TNO, ASML, Shell, UT,
VKI, Philips, LMS (Be), LAUM
(Universite du Maine, FR), GIPSA
(Grenoble, Fr), Flowairs (EC
project, TU/e Applied Math.),
Tango (EC project, TU/e Wb),
Jeronimo (EC project)

FUNDED

| | |
|--------------|------|
| University | , EU |
| University | 90 % |
| FOM | - |
| STW | - |
| NWO Other | - |
| Industry | - |
| TNO | - |
| GTI | - |
| EU | 10 % |
| Scholarships | - |

START OF THE PROJECT

2002

INFORMATION

A Hirschberg
040 2547 21 63
A.Hirschberg@tue.nl

PROJECT AIM

The quantitative prediction of unsteady shedding of vortices in confined flows and the interaction of these vortices with acoustic waves. Prediction of self-sustained flow-instabilities in high-pressure gas transport systems and impact of such instabilities on volume flow measurements. The focus of the project is presently on fundamental aspects of the design of mufflers and the whistling of corrugated pipes.

PROGRESS

-The whistling of corrugated pipes has been studied. A linear model has been developed to predict the flow conditions at the onset of whistling. The influence of corrugation geometry has been studied (publication ASME).

-A low frequency approximation has been proposed for the acoustic radiation from an open pipe termination exhausting a hot gas (TU/e, Wb).

-The influence of the Coanda effect on human speech production has been studied (IPG/ GIPSA), two conference papers CFA 2014.

-A study is initiated in collaboration with the Laboratoire d'Acoustique de l'Universite du Maine (LAUM) on efficient high amplitude sound sources.

-A study on the influence of stiction on the noise generated by valves has been initiated in collaboration with the University of Rennes (Dept. Applied Math.).

DISSERTATIONS

-

SCIENTIFIC PUBLICATIONS

1. A.Hirschberg and P.G.M. Hoeijmakers, "Comments on the low frequency radiation impedance of a duct exhausting a hot gas", Journal of the Acoustical Society of America, 136 (2014) EL-84-89.
2. O. Rudenko, G. Nakiboglu, A. Hirschberg, "Onset of tonal noise in corrugated pipe segments", Journal of Pressure Vessel Technology, ASME 136 (2014) 051303-1/8.
3. A.Hirschberg, J. Haas, X. Pelorson, "Asymmetry in lateral forces on vocal folds due to the Coanda effect", proceedings of the 12th Conference Française d'Acoustique (CFA), Poitiers, 15-22 April 2014, paper 114.
4. J. Haas, X. Pelorson, A.Hirschberg, "The Coanda effect and asymmetries in vocal fold models during phonation", proceedings of the 12th Conference Française d'Acoustique (CFA), Poitiers, 15-22 April 2014, paper 255.

PROJECT AIM

Colloidal particles are commonly used as stabilizers for fluid-fluid interfaces. In this project a system of colloidal particles suspended in two immiscible fluids (water and oil) is being considered. The lattice Boltzmann method is used to simulate the two fluids, while the suspended particles are simulated by molecular dynamics. A particular focus of this PhD project is on anisotropic particles such as rods, cylinders, platelets and ellipsoids, where the role of capillary and electrostatic particle-particle interactions shall be investigated.

PROGRESS

The code for Janus particles (particles with areas of different wettability) was implemented in the simulation code. Simulation studies with Janus particles were done. Furthermore the writeup of the thesis was started.

DISSERTATIONS

-

SCIENTIFIC PUBLICATIONS

1. Timescales of emulsion formation caused by anisotropic particles. F. Günther, S. Frijters, J. Harting. *Soft Matter* 10, Number 27, 4977-4989 (2014).

PROJECT LEADERS

J Harting

RESEARCH THEME

Complex dynamics of fluids

PARTICIPANTS

F Günther

COOPERATIONS

-

FUNDED

| | |
|--------------|-------|
| STW | |
| University | - |
| FOM | - |
| STW | 100 % |
| NWO Other | - |
| Industry | - |
| TNO | - |
| GTI | - |
| EU | - |
| Scholarships | - |

START OF THE PROJECT

2010

INFORMATION

FS Günther

040 247 5140

f.s.guenther@tue.nl

TRUE SOLVENT FREE: TOWARDS THE NEXT GENERATION WATERBORNE COATINGS

PROJECTLEADERS

HP Huinink, P Venema, J Harting

RESEARCHTHEME

Complex dynamics of fluids

PARTICIPANTS

M Wouters, J Harting

COOPERATIONS

-

FUNDED

DSM Coating Resins, AkzoNobel,

Océ, Drywood, STW

University -

FOM -

STW 75 %

NWO Other -

Industry 25 %

TNO -

GTI -

EU -

Scholarships -

START OF THE PROJECT

2014

INFORMATION

M Wouters

040 247 4217

M.p.j.wouters@tue.nl

[www.tue.nl/universiteit/faculteiten/
technische-natuurkunde/de-faculteit/
medewerkers/detail/ep/e/d/
ep-uid/20060589/](http://www.tue.nl/universiteit/faculteiten/technische-natuurkunde/de-faculteit/medewerkers/detail/ep/e/d/ep-uid/20060589/)

PROJECT AIM

The scientific aim is to understand film formation of new coatings consisting of polymer particles (acrylate based) that can be plasticized by water. The project aims to develop a simulation model that connects film drying with the chemistry of the polymer particles and the environmental conditions to enable a targeted design of waterborne coatings. Furthermore it tries to identify handles for designing fully waterborne coatings with improved performance.

PROGRESS

The literature study has been started, as well as the first simulations with a simulation code which combines the lattice Boltzmann method (LBM) with the immersed boundary method (IBM).

DISSERTATIONS

-

SCIENTIFIC PUBLICATIONS

-

PROJECT AIM

The aim of this project is to study the physics of dewetting of thin liquid layers on partially wetting surfaces. The evaporation of these films causes technological difficulties, as cooling due to the large latent heat of evaporation of water leads to inhomogeneous thermal contractions of substrates. At the focus is the question whether the dewetting and break-up process of the water layer into droplets can be influenced regarding the size distribution and arrangement of the resulting droplets.

PROGRESS

A numerical model for the dynamics of spontaneous and induced break-up of model liquids has been developed. An experimental setup for dry-spot nucleation induced by an air-jet has been built and systematic experiments have been performed. A second setup for temperature-gradient-induced dry-spot nucleation has been designed and built and is currently being used for a systematic study. A third setup for moving airjets has been designed and built. A complete study of the influence of all relevant parameters on the deformation of the thin liquid film and the resulting break-up behavior and residual droplet distributions has been performed.

DISSERTATIONS

-

SCIENTIFIC PUBLICATIONS

1. H. M. J. M. Wedershoven, C. W. J. Berendsen, J. C. H. Zeegers, and A. A. Darhuber, Infrared laser induced rupture of thin liquid films on stationary substrates, APPLIED PHYSICS LETTERS 104, 054101 (2014).

PROJECTLEADERS

AA Darhuber

RESEARCHTHEME

Complex dynamics of fluids

PARTICIPANTS

C Berendsen, J Zeegers,
AA Darhuber

COOPERATIONS

ASML

FUNDED

| | |
|-------------------------|------|
| FOM-IPP met ASML en Oce | |
| University | - |
| FOM | 50 % |
| STW | - |
| NWO Other | - |
| Industry | 50 % |
| TNO | - |
| GTI | - |
| EU | - |
| Scholarships | - |

START OF THE PROJECT

2010

INFORMATION

AA Darhuber

a.a.darhuber@tue.nl

ACTIVE CONTROL OF SOLUTION PROCESSING OF ORGANIC ELECTRONIC DEVICES

PROJECT LEADERS

AA Darhuber, J Harting

RESEARCH THEME

Complex dynamics of fluids

PARTICIPANTS

Q Xie, B Wedershoven

COOPERATIONS

-

FUNDED

STW

University -

FOM -

STW 100 %

NWO Other -

Industry -

TNO -

GTI -

EU -

Scholarships -

START OF THE PROJECT

2014

INFORMATION

AA Darhuber

a.a.darhuber@tue.nl

PROJECT AIM

This project aims at generating insight into and implementing control of evaporative deposition processes in the context of organic electronics manufacturing. Quantitative experiments and computer simulation will be combined to develop a validated process simulation tool. This tool will be used to develop and test strategies for the active control of the deposition process and the elimination of layer non-uniformities. Control strategies include for instance laser induced non-uniform temperature distributions.

PROGRESS

Quantitative experiments regarding infrared laser manipulation of thin liquid films of pure liquids on completely and partially wetting substrates have been performed. The results could be reproduced quantitatively by numerical model calculations. Regarding the development of large scale lattice-Boltzmann simulations, the following milestones were achieved:

1. Implementation of heat transfer model for single-component fluids;
2. A charge transport model is developed for single-component fluids (with static charged colloid) and multi-component fluids;
3. Evaporation model of drying droplet with/without colloidal suspension; reproduced coffee-ring stain effect and rush-hour phenomena.

DISSERTATIONS

-

SCIENTIFIC PUBLICATIONS

1. H. M. J. M. Wedershoven, C. W. J. Berendsen, J. C. H. Zeegers, and A. A. Darhuber, Infrared laser induced rupture of thin liquid films on stationary substrates, APPLIED PHYSICS LETTERS 104, 054101 (2014).

MICROSCALE SIMULATION OF DEFORMABLE PARTICLES AT FLUID-FLUID INTERFACES

PROJECT AIM

Particles added to an interface can be used as a surface stabilizer for the food and cosmetic industries. Gels are a class of soft colloidal particles whose elasticity and interfacial tension are important on their adsorption at an interface. The aim of this project is to calculate the shape of such a particle at a fluid-fluid interface using molecular dynamics simulations.

PROGRESS

As the first step, it is assumed that the particle is two-dimensional. It is also assumed that its shape can be characterized using the linear elasticity framework which means that the particle is in the small deformation regime. Then the corresponding molecular dynamics setup is made and the results are compared with a theoretical model.

DISSERTATIONS

-

SCIENTIFIC PUBLICATIONS

-

PROJECT LEADERS

J Snoeijer, J Harting

RESEARCH THEME

Complex dynamics of fluids

PARTICIPANTS

H Mehrabian

COOPERATIONS

-

FUNDED

| | |
|--------------|-------|
| STW | |
| University | - |
| FOM | - |
| STW | 100 % |
| NWO Other | - |
| Industry | - |
| TNO | - |
| GTI | - |
| EU | - |
| Scholarships | - |

START OF THE PROJECT

2014

INFORMATION

H Mehrabian

06 10616742

mehrabian@outlook.com

PROJECTLEADERS

J Zeegers

RESEARCHTHEME

Complex dynamics of fluids

PARTICIPANTS

D Saha, J Zeegers, J Kuerten

COOPERATIONS

-

FUNDED

STW, Industry

University -

FOM -

STW 80 %

NWO Other -

Industry 20 %

TNO -

GTI -

EU -

Scholarships -

START OF THE PROJECT

2009

INFORMATION

J Zeegers

040 247 4212

j.c.h.zeegers@tue.nl

PROJECT AIM

Developing a vortex tube swirling flow system to separate condensate out of gas flow.

PROGRESS

In the past year the focus has been on separation of water condensate that is artificially injected upstream of the vortex tube. There is a slight increase of the moist content on the hot side due to the natural equilibrium in the entrance of the vortex tube, but extracting droplets from the tube itself has a low efficiency. Separation experiments have also been done on the cold side of the vortex tube. Here water is physically available in the form of droplets that can be separated. Further studies will be made in 2015, as well as LDA measurements in the vortex chamber and cold side. The project ends in september 2015.

DISSERTATIONS

-

SCIENTIFIC PUBLICATIONS

1. D. Saha, J.C.H. Zeegers, J.G.M. Kuerten, Separation of water droplets in the Ranque Hilsch Vortex Tube. Proceedings of the 13th Int. Conf. Multiphase Flow Ind. Plant. Sept 17-19, 2014.



Prof.dr. HJH Clercx



Prof.dr.ir. GJF van Heijst



Prof.dr. F Toschi



Prof.dr.ir. BJ Geurts

The research in this section concerns transport phenomena, in particular as occurring in turbulent flows. An important line of approach is that vortex dynamics, in which elementary processes are studied in rather isolated configurations. Special attention is given to the influence of body forces associated with background rotation and density stratification. Such situations are met in industrial settings and also within the framework of geophysical fluid dynamics. In addition to transport in turbulent flows, the dynamics of granular media and 3D viscous mixing is studied.

The following main lines of research can be distinguished:

1. Spectral and transport properties of 3D turbulence
2. Dispersion in quasi-2D turbulence
3. Atmospheric physics
4. Granular media and viscous mixing

In most of these themes the research approach is a combination of laboratory experiments, numerical simulation, and theoretical modelling.

PHYTOPLANKTON DISPERSION IN GEOPHYSICAL TURBULENCE

PROJECT AIM

The objective of this project concerns the quantification of the vertical turbulent transport of phytoplankton by DNS and the associated process of scum formation at the free surface. This part concerns a combined investigation involving numerical simulations (TU/e), experiments and field observations (Deltares).

PROGRESS

This project has been finished with the thesis of E. Aparicio Medrano.

DISSERTATIONS

1. Aparicio Medrano, E., Physical aspects explaining cyanobacteria scum formation in natural systems. PhD thesis, Eindhoven University of Technology, Eindhoven, The Netherlands.

SCIENTIFIC PUBLICATIONS

-

PROJECT LEADERS

HJH Clercx

RESEARCH THEME

Complex dynamics of fluids

PARTICIPANTS

E Aparicio Medrano, BJH van de Wiel, HJH Clercx

COOPERATIONS

M Dionisio (Deltares),
RE Uittenbogaard (Deltares)

FUNDED

| | |
|--------------|-------|
| Deltares | |
| University | - |
| FOM | - |
| STW | - |
| NWO Other | - |
| Industry | - |
| TNO | - |
| GTI | 100 % |
| EU | - |
| Scholarships | - |

START OF THE PROJECT

2009

INFORMATION

HJH Clercx
040 247 2680
h.j.h.clercx@tue.nl
www.fluid.tue.nl

LAGRANGIAN MIXING ANALYSIS OF HEAT TRANSFER: A NEW WAY FOR THERMAL OPTIMISATION

PROJECT LEADERS

HJH Clercx

RESEARCH THEME

Complex dynamics of fluids

PARTICIPANTS

O Baskan, HJH Clercx

COOPERATIONS

MFM Speetjens (TU/e-Wbt),

EA Demissie (TU/e-Wbt),

G Metcalfe (CSIRO, Australia)

FUNDED

STW

University -

FOM -

STW 100 %

NWO Other -

Industry -

TNO -

GTI -

EU -

Scholarships -

START OF THE PROJECT

2010

INFORMATION

HJH Clercx

040 247 2680

h.j.h.clercx@tue.nl

www.fluid.tue.nl

PROJECT AIM

The objective is in-depth analysis of the Kenics static mixer by Lagrangian mixing analysis of heat transfer. The study is divided into two subprojects: Topological mixing analysis of heat transfer in the Kenics mixer (E. Demissie; Wbt) and Experimental heat-transfer and mixing analysis of the Kenics mixer (O. Baskan, Applied Phys.). The latter subproject focuses on experimental characterization of Lagrangian mixing properties in case studies by measurement of 3D fluid trajectories and evolution of 3D scalar fields using advanced optical measurement techniques. Benchmarking of numerical thermal mixing analyses and testing of the prototype thermal-analysis tools for advanced data processing.

PROGRESS

An extensive parametric study on the evolution of scalar patterns and the coherent flow structures in simplified Rotated Arc Mixer (RAM) facility is conducted experimentally. The results reveal that there is a strong correlation between the scalar patterns and coherent flow structures and the islands in the Poincaré maps are the indicators of 'unmixedness' (Figure 1a top left). Moreover, a realistic 3D inline mixer facility is made operational to investigate the evolution of scalar fields in the mixer. The facility consists of an optically accessible test section with transparent mixing elements and accommodates a pressure-driven pipe flow. Successive placement of the static mixing elements in the axial flow direction results in a spatially periodic flow field. The numerical studies have proven the existence of spatially periodic patterns with exponentially decaying intensities (Figure 1b), which agrees well with the eigenmode analysis of scalar transport in periodic flow fields in literature.

DISSERTATIONS

SCIENTIFIC PUBLICATIONS

1. M.F.M. Speetjens, O. Baskan, G. Metcalfe, and H.J.H. Clercx, Unravelling convective heat transfer in the rotated arc mixer. In: Proceedings of the 15th International Heat Transfer Conference, IHTC-15. August 10-15, 2014, Kyoto, Japan.

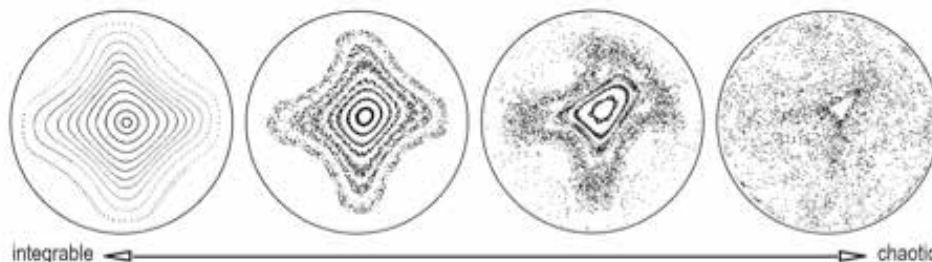

Directly measured Poincaré maps. The maps show Hamiltonian progression of the Lagrangian flow topology of the 2D time-periodic RAM

ROTATING RAYLEIGH BENARD EXPERIMENTS: TUNING THE TRANSITION BETWEEN TURBULENT STATES

PROJECT AIM

Rayleigh-Bénard convection (RBC) is the laboratory realization of buoyancy-driven convection, which is relevant to many natural phenomena and industrial applications. Since these processes are often coupled with system rotation, its effect on RBC is also of interest. In general, depending on the system parameters, the Rayleigh-Bénard system can exist in multiple turbulent states with different heat transfer characteristics. The aim of this project is to explore the possibility of tuning the transitions between various turbulent regimes of RBC (rotating as well as non-rotating) by adding particles to the fluid.

PROGRESS

The following points summarize the progress made during the year 2014.

1. The performance of the Rayleigh-Bénard system was checked and the results of preliminary heat transfer measurements without system rotation are in agreement with those in the literature.

2. Various particles from different manufacturers were tested to select the best option available. We have decided to use silver coated hollow ceramic spheres with mean diameter ~90 microns.

3. Since the particles supplied by the vendor have a wide range of density, we need to extract a fraction with density close to that of the working fluid, viz., water. The methods to achieve this density segregation have been tested and finalized.

4. Currently we are testing and automating the injection system to introduce particles into the Rayleigh-Bénard cell and preparing the first experiments.

DISSERTATIONS

-

SCIENTIFIC PUBLICATIONS

-

PROJECT LEADERS

HJH Clercx, F Toschi

RESEARCH THEME

Complex dynamics of fluids

PARTICIPANTS

PR Joshi, HJH Clercx, F Toschi,

RPJ Kunnen, KMJ Alards, H Rajaei

COOPERATIONS

G Ahlers (UCSB), B Geurts (UT),

D Lohse (UT), R Verzicco (Roma)

FUNDED

FOM

University -

FOM 100 %

STW -

NWO Other -

Industry -

TNO -

GTI -

EU -

Scholarships -

START OF THE PROJECT

2014

INFORMATION

HJH Clercx

040 247 2680

h.j.h.clercx@tue.nl

RPJ Kunnen

040 247 3194

r.p.j.kunnen@tue.nl

www.phys.tue.nl/wdy

Schematic of the Rayleigh-Bénard cell: (a) side view; (b) top view. CW: cooling water; CP: copper plates; TS: temperature sensors; SW: side walls; SH: secondary heaters; AS: adiabatic shields; RH: Resistance heaters; BT: Bleed tube for deaeration; IT: Tube for particle injection.

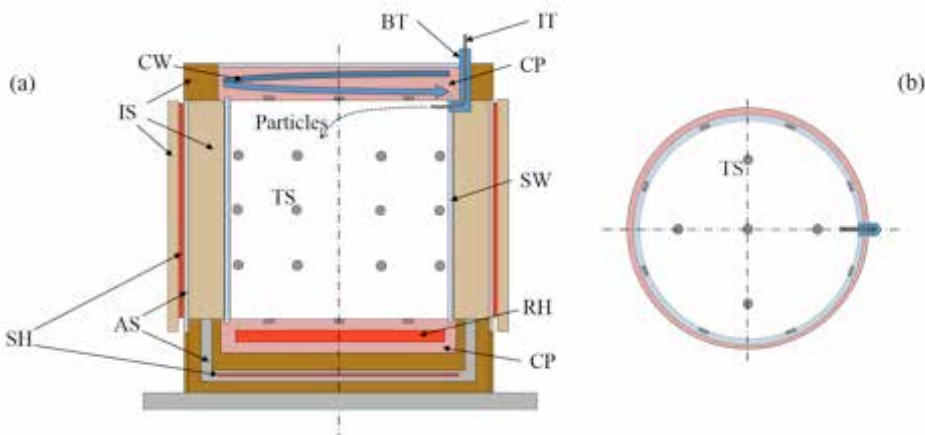

PROJECT LEADERS

HJH Clercx

RESEARCH THEME

Complex dynamics of fluids

PARTICIPANTS

SJ Kaptein, BJH van de Wiel, HJH Clercx

COOPERATIONS

M Blaas (Deltares, Utrecht),

J Pietrzak (TU Delft),

V Armenio (University of Trieste)

FUNDED

STW

University -

FOM -

STW 100 %

NWO Other -

Industry -

TNO -

GTI -

EU -

Scholarships -

START OF THE PROJECT

2014

INFORMATION

HJH Clercx

040 247 2680

h.j.h.clercx@tue.nl

www.phys.tue.nl/wdy/

PROJECT AIM

The aim of the project is to use DNS (Direct Numerical Simulation) and LES (Large Eddy Simulations) to explore the role of tidal straining on the mixing-stratifying competition. It is also an objective to improve turbulent closures for application in Delft3D (Deltares) using simulation results and field data (made available by the Port of Rotterdam), which specifically take into account anisotropy due to inhomogeneous horizontal and vertical conditions.

PROGRESS

During the first period most time have been spent in gathering information by literature research, exploration of numerical techniques and sharpening of the research question. The software LES-Coast (from Univ. Trieste) has been installed and is working. The first simulations have been undertaken. They include very simple cases (laminar flow) in order to get familiar with the physics and to understand (and solve) several numerical problems. These simulations will be pursued and additional complexity is added in a stepwise manner in order to reach a realistic model for the Rhine ROFI.

DISSERTATIONS

-

SCIENTIFIC PUBLICATIONS

-

A NEW WAY OF UNDERSTANDING CHAOTIC WIND BURSTING AT NIGHT

PROJECT AIM

The project aims to find the physical mechanism that drives intermittent (discontinuous) turbulence in the nocturnal atmospheric boundary layer. During intermittency, periods with 'laminar' flow are interrupted by chaotic bursts of turbulence and a significant transport of heat, moisture and momentum occurs. Key tools are theoretical analyses combined with Direct Numerical Simulation (DNS) techniques.

PROGRESS

In a nocturnal atmospheric boundary layer with clear skies and weak wind a laminarization of the flow may occur which means that the turbulence may suddenly become very weak. Here this collapse of turbulence is studied by means of DNS of a stably stratified channel flow. Previous results by Nieuwstadt (2005) showed that there is a critical cooling rate for which turbulence cannot survive. Here, the collapse of turbulence is explained by a new hypothesis: the maximum sustainable heat flux theory. It is shown that the critical cooling rate predicted by this theory agrees well with the simulated value. Additionally, the theory predicts a revival of turbulence in the long term; in pressure driven flow, the collapse leads to an acceleration of the mean flow, which ultimately enables a recovery of turbulence. The simulations revealed that such recovery indeed occurs, provided that perturbations of finite amplitude are present (see Figure).

DISSERTATIONS

-

SCIENTIFIC PUBLICATIONS

-

PROJECTLEADERS

BJH van de Wiel , HJH Clercx,
GJF van Heijst

RESEARCHTHEME

Complex dynamics of fluids

PARTICIPANTS

JMM Donda, BJH van de Wiel,
IGS van Hooijdonk,
HJH Clercx, GJF van Heijst

COOPERATIONS

A Moene (WUR), H Jonker (TUD),
P Baas (KNMI)

FUNDED

| | |
|--------------|-------|
| Vidi NWO-ALW | |
| University | - |
| FOM | - |
| STW | - |
| NWO Other | 100 % |
| Industry | - |
| TNO | - |
| GTI | - |
| EU | - |
| Scholarships | - |

START OF THE PROJECT

2010

INFORMATION

BJH van de Wiel
040 247 4285
b.j.h.v.d.wiel@tue.nl
www.phys.tue.nl/wdy/

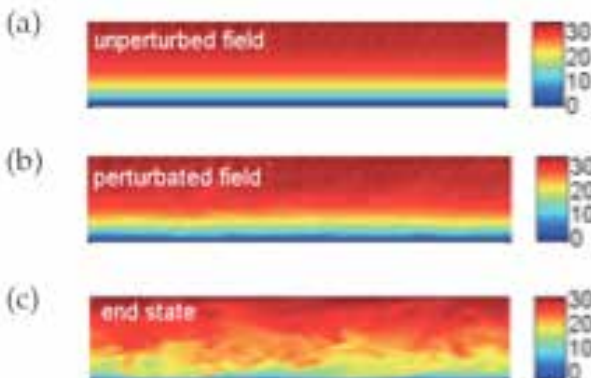

vertical cross section of the horizontal velocity field after collapse due to strong surface cooling. The figures illustrate the recovery to a turbulent state in case when the laminar flow is perturbed with finite size perturbations

ROTATING RB TURBULENCE: EXPERIMENTS

PROJECT LEADERS

HJH Clercx

RESEARCH THEME

Complex dynamics of fluids

PARTICIPANTS

H Rajaei, HJH Clercx, RPJ Kunnen,
F Toschi, KMJ Alards, PR Joshi

COOPERATIONS

-

FUNDED

FOM

University -

FOM 100 %

STW -

NWO Other -

Industry -

TNO -

GTI -

EU -

Scholarships -

START OF THE PROJECT

2013

INFORMATION

HJH Clercx

040 247 2680

h.j.h.clercx@tue.nl

www.phys.tue.nl/wdy/

PROJECT AIM

This project focusses on exploring with 3D Particle Tracking Velocimetry (3D-PTV) how the Lagrangian dynamics of (fluid) particles can be utilized for turbulent state characterization, how the flow transition from one state to the other in rotating convection will affect the Lagrangian statistics of (fluid) particles, and how particle and thermal inertia affect particle dynamics in (rotating) convection.

PROGRESS

Measurements of the velocity and acceleration of the neutrally buoyant particles have been performed for 8 different rotation rates in the center of the RB cell. In parallel to the experiments, numerical simulations (Direct Numerical Simulation) have been performed concerning the center of the cell. Good agreements between experiments and simulations are observed. The experiments for the same 8 different rotation rates have been repeated for the region close to the top lid. These data show how rotation affects the velocity and acceleration of neutrally buoyant particles. Apart from the acceleration and velocity PDFs, the Lagrangian autocorrelation functions for both velocity and acceleration are calculated for different rotation rates.

DISSERTATIONS

-

SCIENTIFIC PUBLICATIONS

-

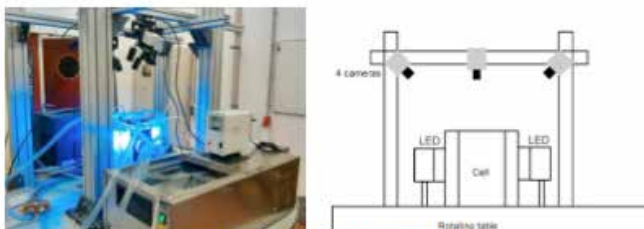
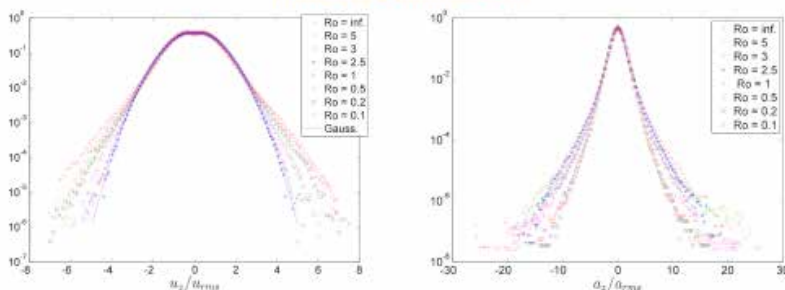

Figure 1. Experimental setup



Normalized vertical-velocity pdfs (left) and normalized vertical-acceleration pdfs (right) at the center of the cell.

HOW GRAVITY, SHEAR AND COALESCENCE MODIFY THE DROPLET SIZE DISTRIBUTION

PROJECT AIM

The goal is to address the basic phenomenology of droplets under realistic situations, the focus being on large-scale behavior. In this study the focus will be on the effects of gravity and of shear on droplet transport and collision rates.

PROGRESS

The spectral code got a major revision. New tests have been added for reliability of the code. The documentation of the code is updated. Simulations have been done to investigate the influence of shear on the gravitational settling of particles. A model has been developed to explain the drift velocity for heavy particles in the horizontal direction while the shear velocities are directed in the vertical direction.

DISSERTATIONS

-

SCIENTIFIC PUBLICATIONS

1. De Pietro, M., Hinsberg, M.A.T. van, Biferale, L., Clercx, H.J.H., Perlekar, P. & Toschi, F. (2014). On clustering of vertically constrained passive particles in homogeneous, isotropic turbulence. arXiv.org No. 1411.1950 [physics.flu-dyn], 8 pp.



the advection of tracers in a homogeneous shear flow

PROJECT LEADERS

F Toschi, HJH Clercx, GJF van Heijst

RESEARCH THEME

Complex dynamics of fluids

PARTICIPANTS

MAT van Hinsberg, HJH Clercx,

F Toschi

COOPERATIONS

L Biferale (Rome, Italy), P Perlekar

(TIFR, Hyderabad, India),

J ten Thije Boonkkamp (W&I-TU/e)

FUNDED

FOM

University -

FOM 100 %

STW -

NWO Other -

Industry -

TNO -

GTI -

EU -

Scholarships -

START OF THE PROJECT

2011

INFORMATION

HJH Clercx

040 247 2680

h.j.h.clercx@tue.nl

F Toschi

040 247 3911

f.toschi@tue.nl

www.phys.tue.nl/wdy/

PROJECT LEADERS

HJH Clercx, GJF van Heijst

RESEARCH THEME

Complex dynamics of fluids

PARTICIPANTS

VH Fernandes, LPJ Kamp,
GJF van Heijst, HJH Clercx

COOPERATIONS

N Lopes Cardozo (TU/e-TN),
R Jaspers (TU/e-TN),
M de Baar (FOM; TU/e-Wbt)
M Lauret (TU/e-Wtb)

FUNDED

| | |
|--------------|-------|
| TUE | |
| University | 100 % |
| FOM | - |
| STW | - |
| NWO Other | - |
| Industry | - |
| TNO | - |
| GTI | - |
| EU | - |
| Scholarships | - |

START OF THE PROJECT

2010

INFORMATION

HJH Clercx
040 247 2680
h.j.h.clercx@tue.nl

GJF van Heijst
040 247 2722
g.j.f.v.heijst@tue.nl
www.phys.tue.nl/wdy/

PROJECT AIM

Large-scale coherent flows play an important role both in geophysical fluids and in fusion plasmas since they interact with the turbulence and can give rise to transport barriers. With relatively simple fluid dynamics experiments in combination with numerical simulations we study how zonal flows affect turbulence and turbulent transport. In this project visualisation of the effect of flow on turbulence is a key element, whereas the fluid dynamics experiment will also serve as a test bed for control methods (link with project "Control of plasma transport by plasma flow" which is being conducted at Dept. Mech. Engineering, TU/e).

PROGRESS

We have experimentally validated previously obtained numerical results on the interaction between a shear-flow and a dipole initially propagating perpendicular to it. Furthermore, we also studied experimentally the evolution of a dipole injected obliquely into a shear flow. In this case an unexpected curvature was observed in the trajectory of the dipole, even in the absence of a shear-flow. The content of this study was compiled into a manuscript that will be submitted to a scientific journal. Besides completing this study, two others were initiated. One of the studies involves the characterization of a novel method to generate dipolar vortices in shallow fluids and the other focusses on the characterization of secondary motions i.e. three-dimensional effects in shallow dipolar structures resulting from a fluid injection mechanism.

DISSERTATIONS

-

SCIENTIFIC PUBLICATIONS

-

PROJECT AIM

Traditional approaches for underground gas and heat recovery suffer from incomplete throughflow of the production fluid due to “short-circuiting” via large fractures and relatively low diffusion towards fractures. The project adopts a radically different approach based on chaos theory which can significantly boost performance by (i) distributing production fluids throughout the entire reservoir and (ii) promoting diffusion of gas or heat towards fractures by inducing large gradients. Principal aim is development of a computational strategy that enables a new way of reservoir analysis. Key to this is definition of closure models by lattice Boltzmann simulations.

PROGRESS

Activities to date concentrated on familiarization with methods and concepts from chaos theory and the Lattice Boltzmann Method (LBM). The figure below gives a first computational result: developing flow in a network of 5 parallel channels versus a porous medium (randomly generated porous network) using LBM.

DISSERTATIONS

-

SCIENTIFIC PUBLICATIONS

-

PROJECTLEADERS

MFM Speetjens, F Toschi

RESEARCHTHEME

Complex dynamics of fluids

PARTICIPANTS

S Varghese, MFM Speetjens, RR Trieling, F Toschi

COOPERATIONS

-

FUNDED

- FOM (CSER programme) University -
- FOM 100 %
- STW -
- NWO Other -
- Industry -
- TNO -
- GTI -
- EU -
- Scholarships -

START OF THE PROJECT

2014

INFORMATION

MFM Speetjens
 040 247 5428
 m.f.m.speetjens@tue.nl
 W: www.energy .tue.nl

F Toschi

040 247 3911

f.toschi@tue.nl

www.phys.tue.nl/wdy

developing flow in a network of 5 parallel channels (top) versus a randomly generated porous network (bottom) using LBM for a fixed pressure drop. Shown are evolutions of isocontours of the velocity magnitude in time (from left to right).

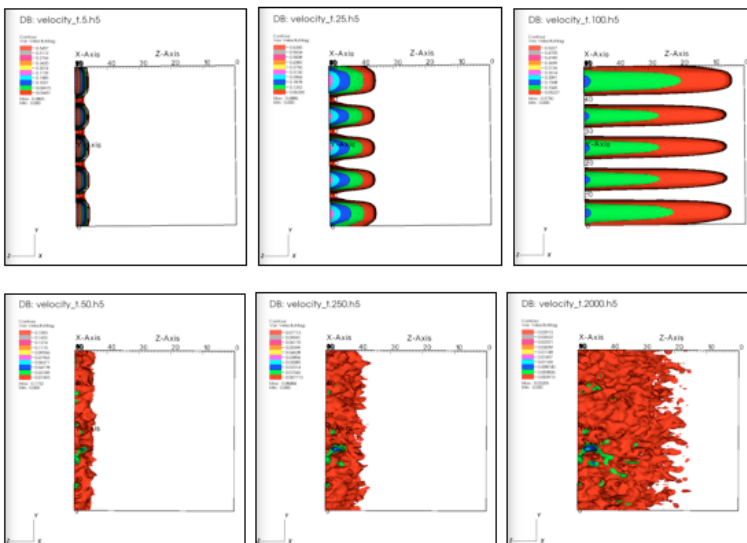

PROJECT LEADERS

F Toschi, L Biferale (Tor Vergata, Italy)

RESEARCH THEME

Complex dynamics of fluids

PARTICIPANTS

R Scatamacchia, F Toschi

COOPERATIONS

L Biferale (Tor Vergata, Italy),
AS Lanotte (ISAC, SNR),
M Sbragaglia (Tor Vergata, Italy)

FUNDED

| | |
|---------------------------|-------|
| University of Tor Vergata | |
| University | 100 % |
| FOM | - |
| STW | - |
| NWO Other | - |
| Industry | - |
| TNO | - |
| GTI | - |
| EU | - |
| Scholarships | - |

START OF THE PROJECT

2012

INFORMATION

F Toschi
040 247 3911
f.toschi@tue.nl
www.phys.tue.nl/wdy/

PROJECT AIM

The project is a dual-degree collaboration between TU/e and University of Tor Vergata (Italy). The goal of the project is to study the behavior of few prototypical examples of complex flows and complex fluids.

PROGRESS

In the first part of the project the focus was on the dynamics of tracers and inertial particles dispersed by point sources in homogeneous and isotropic turbulence velocity fields. The system is the simplest model for dispersion in the atmosphere (e.g. ashes from volcanic sources or pollutants from industrial chimneys). The massively parallel simulation with extraordinary high statistics allowed to measure, for the first time, deviations from Richardson dispersion due to finite flow velocity. Also thanks to our huge statistics we are able to characterize, in a quantitative way, the difference between tracers and inertial heavy particles dispersion. The thesis has been written and defended in January 2015.

DISSERTATIONS

-

SCIENTIFIC PUBLICATIONS

1. Biferale, L., Lanotte, A.S., Scatamacchia, R. & Toschi, F. (2014). Intermittency in the relative separations of tracers and of heavy particles in turbulent flows. *Journal of Fluid Mechanics*, 757, 550-572.

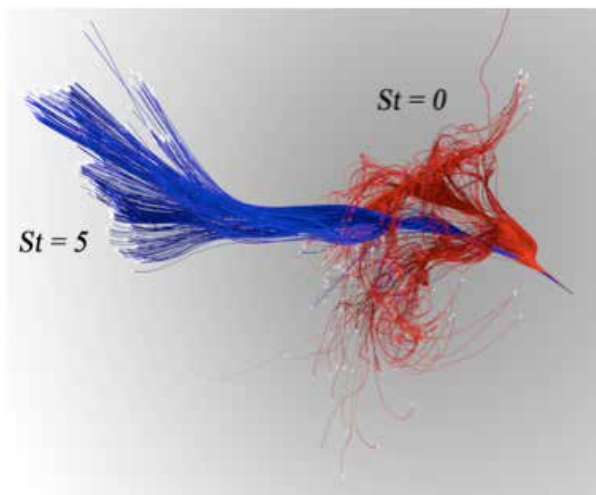

A sketch illustrating the dispersion comparison between a bunch of tracers (red) and inertial heavy particles (blue) released from a point-like source and dispersing in a homogeneous and isotropic turbulent velocity field)

UNRAVELLING 3D MIXING NEAR THE SURFACE OF ACTUATED BEADS

PROJECT AIM

This project focuses on magneto-active mixing and catching by small beads for microfluidic biosensor applications. It concerns the full exploitation of the scavenging properties of magnetic beads in microfluidic devices, control of fluid mixing, and the enhancement of the capture of (biological) targets by the beads. Key in this process is knowledge of the unsteady streamline pattern around a translating and rotating sphere and a detailed understanding of the local mixing properties nearby the sphere surface by laboratory experiments and numerical modelling. Actuation protocols will be devised to enhance the capture probability of target particles by the bead.

PROGRESS

The laboratory experiments and subsequent analysis of particle tracking data has been completed and the concept thesis had been written. The defense is foreseen in autumn 2015.

DISSERTATIONS

-

SCIENTIFIC PUBLICATIONS

-

PROJECTLEADERS

HJH Clercx

RESEARCHTHEME

Complex dynamics of fluids

PARTICIPANTS

NR Moharana, RR Trieling,
GJF van Heijst, HJH Clercx

COOPERATIONS

M Prins (TU/e-TN; Philips),
AM de Jong (TU/e-TN),
J den Toonder (TU/e-Wbt; Philips),
MFM Speetjens (TU/e-Wbt).

FUNDED

| | |
|--------------|-------|
| STW | |
| University | - |
| FOM | - |
| STW | 100 % |
| NWO Other | - |
| Industry | - |
| TNO | - |
| GTI | - |
| EU | - |
| Scholarships | - |

START OF THE PROJECT

2010

INFORMATION

HJH Clercx
040 247 2680
h.j.h.clercx@tue.nl

RR Trieling
040 247 2673
r.r.trieling@tue.nl
www.phys.tue.nl/wdy/

EXPERIMENTAL STUDY OF THE DYNAMICS OF DROPLETS IN TURBULENT SPRAYS AND CLOUDS

PROJECT LEADERS

HJH Clercx, GJF van Heijst

RESEARCH THEME

Complex dynamics of fluids

PARTICIPANTS

DD van der Voort, HJH Clercx,
NJ Dam (TU/e-Wtb), GJF van Heijst,
W van de Water

COOPERATIONS

M Meijer (TU/e-Wtb), AM Yavuz

FUNDED

FOM
University -
FOM 100 %
STW -
NWO Other -
Industry -
TNO -
GTI -
EU -
Scholarships -

START OF THE PROJECT

2013

INFORMATION

GJF van Heijst
040 247 2722
g.j.f.v.heijst@tue.nl
www.phys.tue.nl/wdy/

PROJECT AIM

The main aims are 1) to experimentally investigate the breakup of turbulent jets and sprays by means of phosphorescence, 2) to study the behavior of individual droplets in turbulent sprays and in zero-mean homogeneous isotropic turbulence by Lagrangian measurements, and 3) to explore droplet dispersion in these systems.

PROGRESS

Measurements of dispersion in sprays, using a newly acquired high speed intensified camera, were performed and optimized. Two new setups have been built. The first (see figure (a)) is capable of investigating spray dispersion as a function of ambient pressure, as well as spray velocity and fluid properties. This will allow measurements in a large parameter space, using the phosphorescent tagging method to quantify dispersion. The second setup uses a high speed pressure sensor to detect pressure fluctuations in the injection pressure to correlate pressure fluctuations to measured dispersion fluctuations. Experiments on the dispersion of droplet lines in homogeneous isotropic turbulence (see figure (b)) show that inertial particles at small Stokes numbers disperse faster than true fluid tracers, as well as that the initial separations of the droplets influence the dispersion velocity, an effect that can be explained by caustics.

DISSERTATIONS

-

SCIENTIFIC PUBLICATIONS

1. D.D. van der Voort, W. van de Water, N. Dam, H.J.H. Clercx, G.J.F. van Heijst, "Breakup and dispersion of glowing sprays", Proceedings of the 26th annual conference on Liquid Atomization and Spray Systems, 2014.

(a)

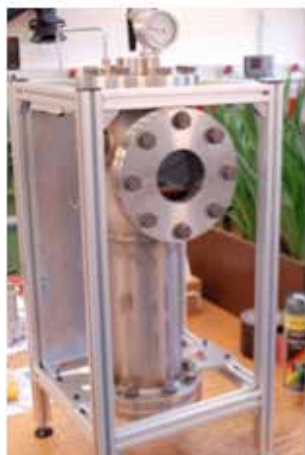

(b)



(a) New experimental setup used to pressurize sprays to 30 bar, and injection sprays with pressures to 200 bar. The nozzles (b) are easily replaced, optically accessible, and capable of continuous injection without interference from the environment.

PROJECT AIM

The project aims at the development, validation and use of the lattice-Boltzmann method for the simulation of various geometries where contact line dynamics is relevant. These problems arise due to the complex geometric structure of the geometry, like in the immersion lithography and the ink-jet printhead.

PROGRESS

This project has been finished with the thesis of S. Srivastava (2014).

DISSERTATIONS

1. S. Srivastava, Lattice Boltzmann method for contact line dynamics, PhD thesis, Eindhoven University of Technology, Eindhoven, The Netherlands.

SCIENTIFIC PUBLICATIONS

-

PROJECTLEADERS

F Toschi

RESEARCHTHEME

Mathematical and computational methods for fluid flow analysis

PARTICIPANTS

S Srivastava, J ten Thije
Boonkkamp, F Toschi

COOPERATIONS

Océ, ASML

FUNDED

| | |
|--------------|-------|
| FOM | |
| University | - |
| FOM | 100 % |
| STW | - |
| NWO Other | - |
| Industry | - |
| TNO | - |
| GTI | - |
| EU | - |
| Scholarships | - |

START OF THE PROJECT

2009

INFORMATION

F Toschi
040 247 3911
f.toschi@tue.nl
www.fluid.tue.nl

ATTRIBUTING THE SOURCES OF TROPOSPHERIC OZONE FROM SPACE: CONSTRAINING BIOGENIC VOC EMISSIONS AND EMISSIONS FROM BIOMASS BURNING

PROJECT LEADERS

KF Boersma, GJF van Heijst

RESEARCH THEME

Complex dynamics of fluids

PARTICIPANTS

MHA van Geel, GCM Vinken,
WW Verstraeten, KF Boersma

COOPERATIONS

KNMI, BIRA, Harvard-Smithsonian

FUNDED

| | |
|--------------|-------|
| NWO-VIDI | |
| University | - |
| FOM | - |
| STW | - |
| NWO Other | 100 % |
| Industry | - |
| TNO | - |
| GTI | - |
| EU | - |
| Scholarships | - |

START OF THE PROJECT

2010

INFORMATION

GJF van Heijst
040 247 2722
g.j.f.v.heijst@tue.nl
www.phys.tue.nl/wdy/

PROJECT AIM

Isoprene, a volatile organic compound (VOC), is a major driver of tropospheric ozone which is produced by photochemical oxidation of VOCs. In this project, we use satellite data as top-down constraints on emissions of isoprene, and derive emissions of HCHO and NO_x from biomass burning. We focus on three tasks: the first two involve biogenic emissions, the third involves biomass burning. We will first evaluate isoprene chemistry in TM5. We then proceed and apply satellite observations of HCHO columns from the GOME(-2), SCIAMACHY, and OMI instruments to better estimate isoprene emissions from biogenic sources and fires.

PROGRESS

This project has been concluded in August 2014.

DISSERTATIONS

-

SCIENTIFIC PUBLICATIONS

-

ATTRIBUTING THE SOURCES OF TROPOSPHERIC OZONE FROM SPACE: MAPPING NO₂ EMISSIONS WITH SATELLITE OBSERVATIONS

PROJECT AIM

Ozone is produced in the troposphere by photochemical oxidation of volatile organic compounds (VOCs) and CO in the presence of nitrogen oxides. These precursors have large and changing anthropogenic and natural sources. We will first improve the description of a number of physical and chemical processes relevant to NO_x emissions in the global models we will use (TM5, GEOS-Chem). We then apply satellite observations of NO₂ columns from the OMI to better estimate NO_x emissions from different categories, including international shipping, lightning, soil, biomass burning, and anthropogenic emissions.

PROGRESS

This project has been finished with the thesis of G.C.M. Vinken (2014).

DISSERTATIONS

1. Vinken, G.C.M., From ships to soil microbes : NO_x emission estimates using OMI satellite retrievals and an improved modelling framework. PhD thesis, Eindhoven University of Technology, Eindhoven, The Netherlands (2014).

SCIENTIFIC PUBLICATIONS

1. Vinken, G.C.M., Boersma, K.F., Donkelaar, A. van & Zhang, L. (2014). Constraints on ship NO_x emissions in Europe using GEOS-Chem and OMI satellite NO₂ observations. *Atmospheric Chemistry and Physics*, 14(3), 1353-1369.
2. Vinken, G.C.M., Boersma, K.F., Maasakkers, J.D., Adon, M. & Martin, R.V. (2014). Worldwide biogenic soil NO_x emissions inferred from OMI NO₂ observations. *Atmospheric Chemistry and Physics*, 14(18), 10363-10381.

PROJECT LEADERS

KF Boersma, PF Levelt,
GJF van Heijst

RESEARCH THEME

Complex dynamics of fluids

PARTICIPANTS

GCM Vinken, MHA van Geel,
WW Verstraeten, KF Boersma

COOPERATIONS

KNMI, Harvard University

FUNDED

| | |
|--------------|-------|
| NWO-VIDI | |
| University | - |
| FOM | - |
| STW | - |
| NWO Other | 100 % |
| Industry | - |
| TNO | - |
| GTI | - |
| EU | - |
| Scholarships | - |

START OF THE PROJECT

2010

INFORMATION

GJF van Heijst
040 247 2722
g.j.f.v.heijst@tue.nl
www.phys.tue.nl/wdy/

ATTRIBUTING THE SOURCES OF TROPOSPHERIC OZONE FROM SPACE: EVALUATING TIME SERIES OF FREE TROPOSPHERIC OZONE OBSERVED FROM SPACE WITH A CHEMICAL TRANSPORT MODEL

PROJECT LEADERS

KF Boersma, GJF van Heijst

RESEARCH THEME

Complex dynamics of fluids

PARTICIPANTS

WW Verstraeten, GCM Vinken,

MHA van Geel, KF Boersma

COOPERATIONS

KNMI, JPL

FUNDED

NWO-VIDI

University -

FOM -

STW -

NWO Other 100 %

Industry -

TNO -

GTI -

EU -

Scholarships -

START OF THE PROJECT

2011

INFORMATION

GJF van Heijst

040 247 2722

g.j.f.v.heijst@tue.nl

www.phys.tue.nl/wdy/

PROJECT AIM

Tropospheric ozone is an important greenhouse gas and a global air pollutant. The fact that ozone in the troposphere reflects the complex interplay of varying spatio-temporal emissions of precursors together with meteorological conditions and atmospheric transport patterns, challenges in-depth interpretation of ozone observations. Spaceborne sensors are excellent tools to map tropospheric ozone patterns thanks to their extensive spatial coverage and frequent overpasses, but understanding and attributing tropospheric ozone concentrations and sources to the observations requires advanced chemical transport models.

PROGRESS

This project has been concluded at TU/e and continued at WUR.

DISSERTATIONS

-

SCIENTIFIC PUBLICATIONS

-

DYNAMICS, COLLISIONS AND COALESCENCE OF DROPLETS IN TURBULENCE

PROJECT AIM

In this experimental project the motion of droplets with diameter of 10 to 50 micrometer in an air-filled turbulence chamber are tracked with 3D particle tracking velocimetry (PTV). The focus is on interactions between droplets (collision or coalescence) and the effect of gravity. We also study the evolution in time of the droplet size distribution with phase-Doppler anemometry (PDA). Turbulence-induced droplet coalescence is the process responsible for rapid precipitation formation; it is, however, not well understood.

PROGRESS

The flow in the turbulence chamber has been fully characterized with PIV. 3D-PTV measurements have been performed to investigate the influence of turbulence on the droplet motions. We are studying the spatial distribution of the droplets in turbulence using the so-called Radial Distribution Function (RDF), which quantifies the clustering of the droplets under turbulence conditions. Indeed, we observe different levels of clustering depending on the turbulence intensity and the mean droplet size. Additionally, 3D-PTV allows us to measure velocity statistics of the droplets and thereby the influence of the turbulence on droplet trajectories, both individually and collectively.

DISSERTATIONS

-

SCIENTIFIC PUBLICATIONS

-

PROJECT LEADERS

HJH Clercx, GJF van Heijst

RESEARCH THEME

Complex dynamics of fluids

PARTICIPANTS

AM Yavuz, MAT van Hinsberg,

RPJ Kunnen, HJH Clercx, F Toschi,

GJF van Heijst

COOPERATIONS

BJ Geurts

FUNDED

FOM

University -

FOM 100 %

STW -

NWO Other -

Industry -

TNO -

GTI -

EU -

Scholarships -

START OF THE PROJECT

2011

INFORMATION

HJH Clercx

040 247 2680

h.j.h.clercx@tue.nl

RPJ Kunnen

040 247 3194

r.p.j.kunnen@tue.nl

www.phys.tue.nl/wdy/

Radial Distribution Function (g) of different sizes of particles in different turbulent conditions

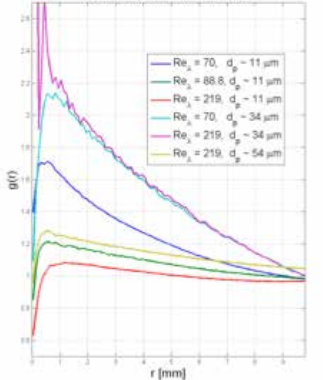

The turbulence chamber at TU/e.



PROJECT LEADERS

F Toschi, HJH Clercx

RESEARCH THEME

Complex dynamics of fluids

PARTICIPANTS

F Tesser, P Perlekar, HJH Clercx,
F Toschi, JCH Zeegers, KMJ Alards

COOPERATIONS

R Benzi (Univ. Tor Vergata, Italy),
L Brunsveld (BMT, TU/e),
MH Jensen (Niels Bohr Institute,
Denmark), DR Nelson (Harvard
University, USA), S Pigoletti
(Universidad politécnica de
Cataluña, Spain)

FUNDED

| | |
|--------------|-------|
| FOM | |
| University | - |
| FOM | 100 % |
| STW | - |
| NWO Other | - |
| Industry | - |
| TNO | - |
| GTI | - |
| EU | - |
| Scholarships | - |

START OF THE PROJECT

2012

INFORMATION

F Toschi
040 247 3911
f.toschi@tue.nl
www.phys.tue.nl/wdy

PROJECT AIM

Population dynamics deals with the study of birth, death and growth processes of biological species. These processes are severely affected by the local ecosystems, by the presence of nutrients, and by the local population density, moreover all these factors can be strongly influenced in a liquid environment by the presence of a flow. Effects can be visible at macroscales in terms of strong non homogeneities. The aim of the present project is to validate the continuum model for the growth of populations extending it to flow conditions, using a combination of dedicated experiments of growth of bacteria in microfluidic devices and numerical discrete particle simulations.

PROGRESS

From experimental side the propagation speed of populations of *E. coli* bacteria has been measured in microfluidic channels under different flow conditions. The effect of fluid velocities and shears, both in the same and opposite direction respect to the front propagation, has been observed. Moreover, from the numerical side, simulations of front propagation in inhomogeneous media have been considered. Mainly two cases have been analyzed: front propagation in cellular flow and front propagation in a random quenched medium composed of high diffusion areas. The output has been characterized in terms of front roughness, front speed and genetic diversity.

DISSERTATIONS

-

SCIENTIFIC PUBLICATIONS

1. Benzi, R., Sbragaglia, M., Perlekar, P., Bernaschi, M., Succi, S. & Toschi, F. (2014). Direct evidence of plastic events and dynamic heterogeneities in soft-glasses. *Soft Matter*, 10(26), 4615-4624.
2. Perlekar, P., Benzi, R., Clercx, H.J.H., Nelson, D.R. & Toschi, F. (2014). Spinodal decomposition in homogeneous and isotropic turbulence. *Physical Review Letters*, 112(1), 014502-1/5.

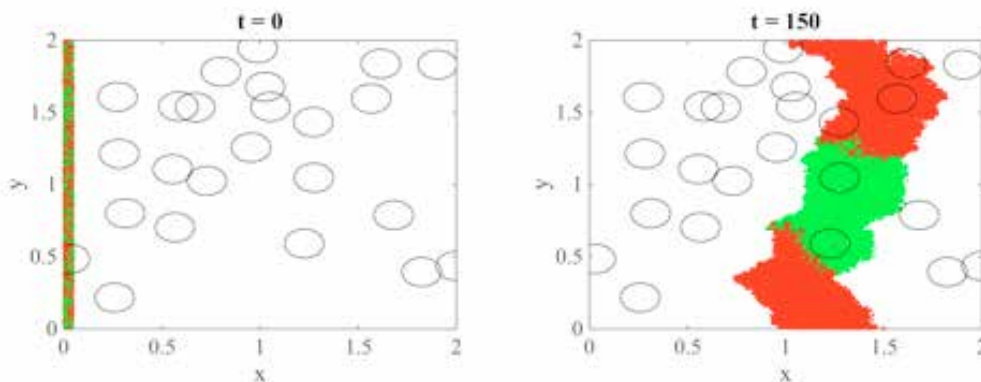

Particle based simulation of front propagation of a two-species population on random medium starting from a thin layer on the left. Both front speed and genetic demixing are affected by the inhomogeneities, in particular the system fixates earlier on average.

PROJECT AIM

Develop a system to visualize and analyze the flow around a human swimmer and extract information from resolved flow field of interest for trainers, coaches and sports scientists. Visualization will be done by means of a bubble system and PIV routine. Furthermore the influence of different and new kinds of feedback to swimmers will be tested on a group of swimmers. In the end the goal is to contribute to improved performance of Dutch elite swimmers.

PROGRESS

More tests are performed to generate bubble curtains which have to meet several conditions in view of the PIV purposes. Furthermore a camera setup to perform PIV in the swimming pool is largely devised and a map shift algorithm is tested to process the images. Artificial images of simplified bubble curtains rising through a well-known flow field are created to study the effect of using bubbles as tracer particle in PIV. Lastly, preliminary simulations of the flow around a swimmer's hand with varying finger spread have been carried out with an immersed boundary technique. Higher resolution simulations are needed to properly resolve the flow in the boundary layers.

DISSERTATIONS

-

SCIENTIFIC PUBLICATIONS

-

PROJECTLEADERS

HJH Clercx

RESEARCHTHEME

Complex dynamics of fluids

PARTICIPANTS

J van Houwelingen, PJ Beek,
HJH Clercx, GJF van Heijst,
RPJ Kunnen, W van de Water

COOPERATIONS

R Verzicco (Roma, Italy),
PJ Beek (VU), J Westerweel (TUD),
InnoSport

FUNDED

| | |
|--------------|-------|
| STW | |
| University | - |
| FOM | - |
| STW | 100 % |
| NWO Other | - |
| Industry | - |
| TNO | - |
| GTI | - |
| EU | - |
| Scholarships | - |

START OF THE PROJECT

2013

INFORMATION

HJH Clercx
040 247 2680
h.j.h.clercx@tue.nl
www.phys.tue.nl/wdy/

PROJECTLEADERS

BJH van de Wiel, HJH Clercx

RESEARCHTHEME

Complex dynamics of fluids

PARTICIPANTS

IGS van Hooijdonk, HJH Clercx,
BJH van de Wiel

COOPERATIONS

-

FUNDED

NWO-ALW
 University -
 FOM -
 STW -
 NWO Other 100 %
 Industry -
 TNO -
 GTI -
 EU -
 Scholarships -

START OF THE PROJECT

2013

INFORMATION

BJH van de Wiel
 040 247 4285
 b.j.h.v.d.wiel@tue.nl
 www.phys.tue.nl/wdy/

PROJECT AIM

A well-known phenomenon in the atmospheric boundary layer is the sudden decrease in turbulence intensity. This generally occurs in the case of weak winds (shear production) strong cooling at the surface (buoyant destruction). Data analysis of atmospheric data (Cabauw weather tower), theoretical analysis and direct numerical simulation are used to investigate this phenomenon. Though originally the research is motivated by meteorological application, we also aim to obtain fundamental insight in the laminarisation of turbulence near a cooled surface.

PROGRESS

Approximately 4500 nights were analysed and classified. Ensemble averages represent typical behaviour of nights with similar characteristics. The resulting climatological data set is compared with the results from theoretical analysis, predicting the occurrence of a quasi-laminar atmospheric boundary layer and a good agreement is found. The final output is a classification parameter that indicates unambiguously if laminarisation occurs or not. This parameter is further supported by theoretical analysis. A numerical study was started. The work in 2014 mainly consists of testing and learning the code and setup. Production runs are expected to start in the first quarter of 2015.

DISSERTATIONS

-

SCIENTIFIC PUBLICATIONS

-

This figure shows the momentum flux (as proxy for turbulence intensity) as a function of the normalised wind speed (Shear Capacity, $SC = U_{actual}/U_{min}$). The data from four different altitudes (10, 20, 40 and 80m) is shown for the weakly stable (blue) and very stable regime (red). The transition between the two regimes is observed at a single value for the Shear Capacity.

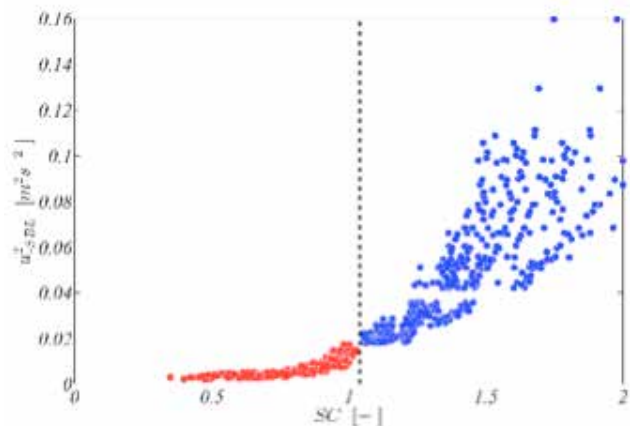

PHOTO-BIOREACTORS: SAVING ALGAE FROM TURBULENCE

PROJECT AIM

The aim of the present project is to investigate numerically and develop models for the statistical properties of hydrodynamics stresses on algae in turbulent environments at different cell concentrations. In the recent past the small-scale statistical properties of (point-wise) particles in turbulence, like their acceleration, have been investigated experimentally and numerically. Numerical methods have been developed and employed to study the rheological properties of very dense suspensions of cells in simple laminar flows. Here we will need to combine the physics and the numerical methods of these previous studies and push both considerably further to challenge the turbulence transport and the statistical properties of (non)-Newtonian dense cell suspensions.

PROGRESS

1. Development of 2D lattice Boltzmann code for solving the Navier Stokes equation for simulation of finite size particles using 4 different particle models.
2. Estimation of optimum particle resolution and confinement ratio.
3. Direct numerical simulation (DNS) of homogeneous isotropic turbulence for several sets of parameters to estimate the optimum Reynolds number for simulations.

DISSERTATIONS

-

SCIENTIFIC PUBLICATIONS

-

PROJECT LEADERS

F Toschi, HJH Clercx

RESEARCH THEME

Mathematical and computational methods for fluid flow analysis

PARTICIPANTS

A Gupta, F Toschi, HJH Clercx

COOPERATIONS

Shell-NWO/FOM

FUNDED

| | |
|---------------|-------|
| Shell-NWO/FOM | |
| University | - |
| FOM | 100 % |
| STW | - |
| NWO Other | - |
| Industry | - |
| TNO | - |
| GTI | - |
| EU | - |
| Scholarships | - |

START OF THE PROJECT

2013

INFORMATION

F Toschi
 040 247 3911
 f.toschi@tue.nl
 www.phys.tue.nl/wdy/

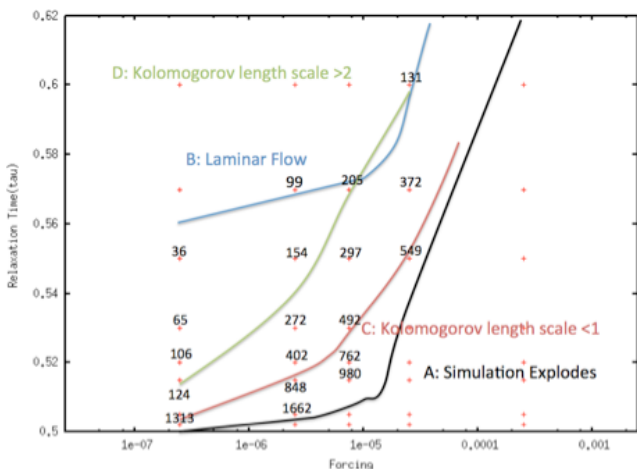

Phase diagram for simulation of homogeneous isotropic turbulence for several set of parameters (relaxation time, forcing amplitude, system size 1283) using Lattice Boltzmann Method. Each point in the plot represents a simulation with its Reynolds Number (based on macroscopic length and velocity estimate).

SEDIMENT TRANSPORT BY VORTICES: A FUNDAMENTAL STUDY FROM THE LAB TO THE OCEAN

PROJECT LEADERS

M Duran Matute

RESEARCH THEME

Complex dynamics of fluids

PARTICIPANTS

M Duran Matute, GJF van Heijst

COOPERATIONS

-

FUNDED

NWO

University -

FOM -

STW -

NWO Other 100 %

Industry -

TNO -

GTI -

EU -

Scholarships -

START OF THE PROJECT

2014

INFORMATION

M Duran Matute

040 247 2160

m.duran.matute@tue.nl

www.phys.tue.nl/wdy/

PROJECT AIM

In environmental flows (e.g. in rivers or at the coast), vortices can play an important role in shaping the sediment bed underneath. The main aim of the project is to provide a complete and coherent theory behind sediment transport by barotropic vortices in such environmental water systems. Through a combination of laboratory experiments and numerical simulations, the full cycle of erosion, transport, and deposition of sediment by the vortices will be systematically studied.

PROGRESS

In the first stage of this project, two main experimental research lines have been undertaken: 1) the study of particle trajectories in the boundary layers below a swirl flow, and 2) the morphodynamics under an oscillating swirl flow. The first study revealed that the trajectories of the particles inside the boundary layers are consistently well defined logarithmic spirals. Only the curvature of the spirals varies with the parameters of the problem. In the second study, the formation of different bed forms was characterized as a function of the amplitude and frequency of the oscillating flow, and the rate of background rotation. The comparison with results from numerical simulations, which are under way, will serve to both gain further insight into the underlying physics and to benchmark the simulations.

DISSERTATIONS

-

SCIENTIFIC PUBLICATIONS

-

STICK TO THE SURFACE!

PROJECT AIM

Main aim is the development of numerical tools to characterize transport of particle debris under combined effects of fluid dynamics and plasma physics. Our aim is to study when and how particles are released from surfaces under the conditions present in EUV lithography tool (hydrodynamic and rarefied gas flows, in presence of harsh and weak plasma environment). This will lead to a clear picture of what occurs inside the tool's plasma and main chambers and how it is possible to influence and, in perspective, prevent potential damaging dust to be released from surfaces.

PROGRESS

To correctly study flow dynamics and debris transport under changing rarefaction conditions relevant for the EUV tool, a hybrid Lattice Boltzmann Method (LBM)-Direct Simulation Monte Carlo (DSMC) numerical tool is being developed. In this view, a parallelized DSMC code has been implemented, extensively benchmarked against literature data, e.g. monodimensional Kramers' problem (see Figure below), slip effects in both velocity and temperature profiles for transitional flows, Rayleigh-Benard convection for rarefied gas, and integrated within LBM code developed at WDY group. A new approach for coupling both numerical methods, based on sampling microscopic properties from flow quantities, has been implemented. First results show that the proposed approach is quantitatively accurate to simulate simple flows (force-driven Poiseuille flow) in the finite-low Knudsen number regime.

DISSERTATIONS

-

SCIENTIFIC PUBLICATIONS

-

Power law velocity profile as computed with implemented DSMC code in proximity to a solid wall for three different $Kn=\lambda/L$ numbers. Found value of the slope ($\alpha=0.81$) is in good agreement with literature data (e.g. Siewert (2003) $\alpha=0.806$, Lilley and Sader (2008) $\alpha=0.83$).

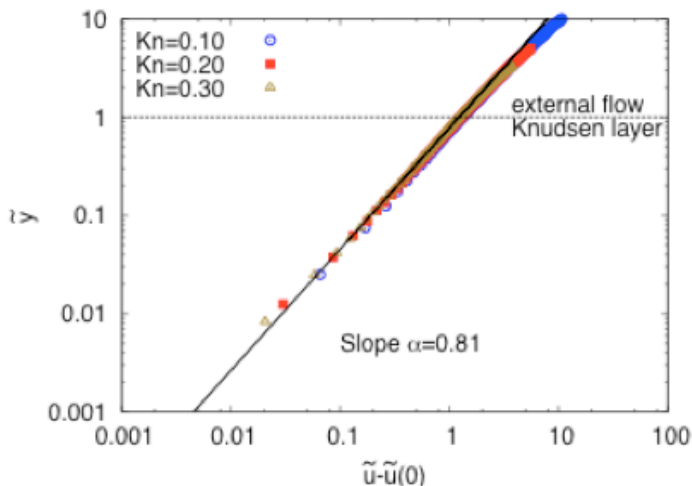

PROJECT LEADERS

HJH Clercx, F Toschi

RESEARCH THEME

Complex dynamics of fluids

PARTICIPANTS

G Di Staso, J van Dijk, S Nijdam,
GMW Kroesen, F Toschi,
HJH Clercx

COOPERATIONS

ASML

FUNDED

STW
University -
FOM -
STW 100 %
NWO Other -
Industry -
TNO -
GTI -
EU -
Scholarships -

START OF THE PROJECT

2014

INFORMATION

HJH Clercx
040 247 2680
h.j.h.clercx@tue.nl

F Toschi
040 247 3911
f.toschi@tue.nl
www.phys.tue.nl/wdy/

ROTATING RAYLEIGH-BÉNARD TURBULENCE: NUMERIC SIMULATIONS

PROJECT LEADERS

F Toschi, HJH Clercx

RESEARCH THEME

Complex dynamics of fluids

PARTICIPANTS

KMJ Alards, HJH Clercx, F Toschi,
RPJ Kunnen, PR Joshi, H Rajaei

COOPERATIONS

-

FUNDED

FOM

University -

FOM 100 %

STW -

NWO Other -

Industry -

TNO -

GTI -

EU -

Scholarships -

START OF THE PROJECT

2014

INFORMATION

F Toschi

040 247 3911

f.toschi@tue.nl

www.phys.tue.nl/wdy/

PROJECT AIM

In this project the dynamics of inertial and buoyant particles in Rayleigh-Bénard convection is investigated numerically. Inertial particles will be implemented in the Rayleigh-Bénard system and the effect of these particle properties on the thermal convection and on the transition between turbulent states explored. In particular, the interest is on the preferential accumulation of particles in plumes and/or vortices, feedback on the flow and the possible modification of the interaction between bulk and boundary layer. Two numerical codes are used, a finite-difference code for exploring a cylindrical setup and a Lattice Boltzmann code for modeling a horizontally unbounded system.

PROGRESS

The progress made in 2014 is:

1. Study fundamental aspects of the problem
2. Study of Lattice Boltzmann Methods of the LB code
3. Improving C programming skills, with specific interest for parallel computing.

DISSERTATIONS

-

SCIENTIFIC PUBLICATIONS

-



Prof.dr.ir. OCG Adan

In the group Transport in Permeable Media, TPM, of the department of Applied Physics at the Eindhoven University of Technology research is performed on transport and phase changes in permeable media. Our mission is to advance materials technology through an in-depth understanding of transport physics in permeable media, in support of various technology domains, such as high tech materials, petro physics and thermal energy storage. The interaction between transport of fluids and solutes, phase changes and material response on different scale levels -typically in the micrometer to millimetre range- forms the core of our research activities. Inherently, interdisciplinarity is in TPMs genes, encompassing transport physics, materials science, chemistry and biology. The experiment is at the heart of the group, which is due to the unique opportunities of our MRI Infrastructure, consisting of nine home-built or -modified scanners operating at fields ranging from 0.7-4.7 T. TPMs research profile is based on use-inspired basic research. Consequently, interaction with industrial players forms a cornerstone in our approach. For this reason, fruitful partnerships exist with TNO, AkzoNobel and Oce. The work is mainly funded by the Dutch Technology Foundation (STW), Materials Innovation Institute (M2I).

OPEN TIME OF GLUE MORTAR

PROJECT AIM

The aim of the project is to understand the parameters that determine the open time of glue mortars. The open time is a crucial parameter for the performance of (glue) mortars for joining material components, such as tiles and bricks. The open time is the time during which tiles can be fixed with a sufficiently good adhesion to the substrate. Exceeding this so-called open time would give a huge reduction in adhesion, because of processes taking place at the surface layer, e.g. drying and hardening. Empirically it is known that the open time has an optimum at specific concentration of specific types of modified cellulose. Obviously, optimizing the adhesive strength plays a central role in product development.

PROGRESS

NMR is used to obtain moisture profile during drying of mortar. Experiments were performed on mortar in presence of different weight percentage of Methylhydroxyethylcellulose (MHEC). We observed a homogeneous drying behavior in mortar without MHEC and a front receding drying with increasing concentration of MHEC. A mathematical model was used to calculate the profiles based on an effective diffusion constant. The diffusion constant incorporates two processes Darcy flow and vapor diffusion. Viscosity change was proven to be the main parameter influencing the drying process. Additionally, the evaporation decreased, which is unexpected since evaporation from cellulose ether solutions is not reduced. We suspect that transport of cellulose ethers creates a film at the surface, that acts as a barrier, which reduces the evaporation of water. We suspect that cellulose ether transport is required to create this film, which was investigated by drying of a model porous system, consisting of glass beads. MRI drying experiments and subsequent Thermo-Gravimetric Analysis (TGA) revealed transport to the surface of the materials.

DISSERTATIONS

-

SCIENTIFIC PUBLICATIONS

-

PROJECT LEADERS

SJF Erich, HP Huinink, OCG Adan

RESEARCH THEME

Complex dynamics of fluids

PARTICIPANTS

APA Faiyas

COOPERATIONS

Materials Innovation Institute (M2i), TNO

FUNDED

| | |
|--------------|-------|
| TNO | |
| University | - |
| FOM | - |
| STW | - |
| NWO Other | - |
| Industry | - |
| TNO | 100 % |
| GTI | - |
| EU | - |
| Scholarships | - |

START OF THE PROJECT

2010

INFORMATION

SJF Erich
040 247 3830
s.j.f.erich@tue.nl

MEASURING, MODELLING AND MONITORING CHLORIDE INGRESS IN CRACKED CONCRETE

PROJECT LEADERS

OCG Adan, L Pel

RESEARCH THEME

Complex dynamics of fluids

PARTICIPANTS

Vacancy

COOPERATIONS

TNO, INTRON, BAM

FUNDED

STW

University -

FOM -

STW 100 %

NWO Other -

Industry -

TNO -

GTI -

EU -

Scholarships -

START OF THE PROJECT

2008

INFORMATION

L Pel

040 241 9742

l.pel@tue.nl

www.phys.tue.nl/nfcmr

PROJECT AIM

The objective of this project is to determine the effect of cracks on the chloride ingress in concrete. This project focuses on the effect of cracks, voids and compaction defects in concrete on chloride transport and on the effect of boundary conditions on the transport processes. The aim is to develop a model which can give a better prediction of the chloride transport over a longer time, i.e., years.

PROGRESS

Within this project a specialized NMR scanner has been developed which has the possibility to measure hydrogen, sodium and chloride quasi simultaneously at 1.5T in a whole body MRI scanner. After some first experiments were performed on non-reactive media as e.g., fired-clay brick, experiments are now being done on reactive porous media, i.e., cementitious materials. Here we have chosen to do these experiments on micro-concrete with a high W/C=0.5, as to have a more open structure. Initial experiments show that there is an exchange of Na and Cl with the pore wall. In a next step we want to perform ion infiltration experiments. These experiments will be performed following ASTM C1202, i.e., the rapid Cl penetration test, which uses an electrical field to speed up the process. In a next step we want to introduce cracks.

DISSERTATIONS

-

SCIENTIFIC PUBLICATIONS

-

TGINK (TOWARDS GREEN INK)

PROJECT AIM

Waterborne inks are the future in the area of inkjet printing, since the use of organic solvents has to be reduced for environmental reasons. In an inkjet process droplets are jetted from the nozzle, hit the paper and start to spread, penetrate the paper and evaporate. This all happens on time scales between 0.001 and 1 s. At present water based inks have three main constituents beside water:

1. Pigment particles for giving color to the image,
2. Polymer particles to create continuous films needed for fixing the pigments and gloss,
3. Co-solvent used to prevent evaporation at the tip of the nozzle.

Water based inks have much in common with waterborne coatings.

When ink droplets hit paper, the polymeric phase has to form a continuous layer on top of the paper sheet. Since in copiers and printers paper gets a heat treatment after being covered with ink, the actual fusion of the polymeric particles is not a problem. It is the arrangement of particles on the paper before the heat treatment which is the critical factor for obtaining a proper film. Little ingress (order of microns) of the polymeric phase promotes adhesion, but deep penetration prevents the formation of a polymeric layer on top of paper and leads to loss in quality of the image. The penetration depth seems to reduce with increasing evaporation rate and is therefore tightly connected with the addition of the co-solvents mentioned before. For the jetting process itself, low evaporation rates are required to prevent blockage of the nozzle, and for a good quality of the image, high evaporation rates are desired. As this project aims to understand the penetration of the ink constituents in paper in relation to the evaporation rate of water, the knowledge gained within this project could be used as a tool for improving ink formulations.

PROGRESS

We developed a model ink containing the main constituents of water-based inks that we build up starting with water making the liquid more and more complex. We investigated the effect of co-solvent on the sorption behavior by capillary suction experiments of water-glycerol mixtures in a simple porous material (Al₂O₃) with a well-defined pore size using NMR imaging. This non-destructive technique allows us to follow the penetration of the liquid into a porous material and distinguish between the different components. The two types of Al₂O₃ we used have an average pore size of 200 nm (similar to the pore size in the coatings on typical printing paper) and 1100 nm (similar to the bulk pore size of printing paper). We found that the penetration of water and water-glycerol in these samples can be described by a modified version of Washburn's equation. And scales with the liquid (Viscosity η , surface tension γ) and media parameters (pore diameter D , tortuosity ϕ). This equation will be a first step for the mathematical model that describes the liquid penetration in paper.

DISSERTATIONS

-

SCIENTIFIC PUBLICATIONS

-

PROJECTLEADERS

HP Huinink, OCG Adan

RESEARCHTHEME

Complex dynamics of fluids

PARTICIPANTS

CJ Kuijpers

COOPERATIONS

Materials Innovation Institute (M2i),

Oce

FUNDED

M2i, Oce

University -

FOM -

STW -

NWO Other -

Industry 100 %

TNO -

GTI -

EU -

Scholarships -

START OF THE PROJECT

2012

INFORMATION

CJ Kuijpers

040 247 4063

c.j.kuijpers@tue.nl

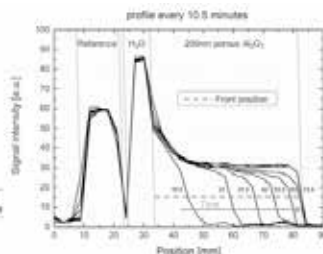
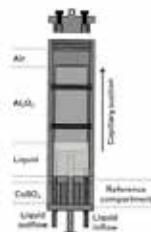

PROJECT LEADERS

OCG Adan, L Pel

RESEARCH THEME

Complex dynamics of fluids

PARTICIPANTS

Vacancy

COOPERATIONS

TNO, NEBEST, Strukton

ENCI, Cosensor

FUNDED

STW

University -

FOM -

STW 100 %

NWO Other -

Industry -

TNO -

GTI -

EU -

Scholarships -

START OF THE PROJECT

2010

INFORMATION

L Pel

040 241 9742

l.pel@tue.nl

www.phys.tue.nl/nfcmr

PROJECT AIM

The goal of this project is to establish a model for chloride ingress in concrete based on the experimental data taken from NMR scanners. Regarding that NMR makes it possible to nondestructively monitor salt concentration, moisture content and porosity changes in position and time, it can provide precise input data for modeling the salt transport in building material.

PROGRESS

The first experiments were performed on diffusion and wick action of sodium chloride transport in fired-clay brick, which is a non-reactive porous medium. As the experiments were much faster than the same experiment for concrete, lots of data were collected to study salt diffusion, advection and crystallization in pore structure during wetting and drying. Hereby we could study the competition between advection/diffusion and the crystallization kinetics. In the meanwhile both the 1.5T and 4.7T NMR setups have been improved to achieve a better signal-to-noise ratio to be able to measure low concentrations of sodium chloride in cementitious materials. Next we want to repeat the same experiments as were done for brick on transport of chloride ions in concrete. Study of the concentration changes of bounded and free chloride and porosity changes during hydration of cement is another set of experiment which are running on the 1.5T scanner as to get better indication of the interaction with ions with a cement.

DISSERTATIONS

-

SCIENTIFIC PUBLICATIONS

-

WATER TRANSPORT THROUGH COATINGS ON WOOD

PROJECT AIM

An important reason to apply coatings on wood is to protect wood against water. In order to use waterborne coatings for wood care the main factors determining transport through these coatings have to be understood. Waterborne coatings are intrinsically more sensitive to water. Further, the influences of wood on the coating structure and permeability have to be understood. In this project the migration of water through waterborne coatings on wood will be studied with NMR imaging tools. NMR imaging is very suitable tool for visualizing water distributions in the wood and the coating. Further, NMR also gives information about the state of water (bound or free) and plasticization effects (polymer-water interactions).

PROGRESS

To investigate water transport through coatings on wood, we started to analyse transport through the wood itself. Oak, teak and pine sapwood were selected as the wood types which covers a whole range of low to high density wood. The first experimental part on uncoated wood was to do the calibration of moisture content for each type with the low resolution NMR. The calibration results showed a good linear relation between NMR signal and moisture content. Allowing us to directly quantify the amount of water from the NMR signal during wetting and drying of wood samples. Relaxation analyses were performed to understand the state of water within the wood, e.g. bound or free water in lumen or voids. Coating were formulated, using well known composition; 3 type of coatings, WB alkyd, SB alkyd and WB acrylic, specifically for this project. Experiments were performed to measure the drying (curing) profiles of the coating systems using high resolution NMR. Next to separate investigation on coatings, e.g. by dynamic vapour sorption, wet cup and high resolution MRI, we have investigated the drying of coated wood.

DISSERTATIONS

-

SCIENTIFIC PUBLICATIONS

-

PROJECTLEADERS

SJF Erich, HP Huinink

RESEARCHTHEME

Complex structures of fluids

PARTICIPANTS

O Gezici

COOPERATIONS

TNO

FUNDED

AKZO/TNO

University -

FOM -

STW -

NWO Other -

Industry 100 %

TNO -

GTI -

EU -

Scholarships -

START OF THE PROJECT

2012

INFORMATION

SJF Erich

040 247 3830

s.j.f.erich@tue.nl

PROJECT LEADERS

L. Pei, OCG Adan

RESEARCH THEME

Complex dynamics of fluids

PARTICIPANTS

PAJ Donkers

COOPERATIONS

Materials Innovation Institute (M2i),

TNO

FUNDED

TNO

University -

FOM -

STW -

NWO Other -

Industry 100 %

TNO -

GTI -

EU -

Scholarships -

START OF THE PROJECT

2011

INFORMATION

PAJ Donkers

040 247 5612

p.a.j.donkers@tue.nl

PROJECT AIM

Renewable energy is of increasingly importance in our modern society. In the Netherlands the main sources of renewable energy are windmills, solar panels and solar collectors. Systems that buffer the energy are needed to match the demand and supply. New systems of heat storage are needed which can store energy with a high energy density and low or no energy loss, i.e. a compact heat storage system which can be introduced in the Dutch building industry. One particular heat storage method with a high potential makes use of the (hydration) crystallization energy of salts. By using thermo chemical energy storage the energy needed for heating in the Netherlands could be reduced by around 50 PJ per year. The aim is to find the most viable salts which are stable over repeated cycles of absorption and release of energy.

PROGRESS

The idea of using crystalline hydrate salts as working media for thermal energy storage has increased the interest in an understanding of their phase transitions. During studying the hydration/dehydration process of hydrates several observations are done. If the vapor transport in a crystal is not sufficient, the released water from a grain can melt part of the grain. This melting is a so called incongruent melting. Melting of part of the grain will strongly effect the grain structure and in that way the cyclicity of a hydrate. This incongruent melting happens around the triple point of different salts. A triple point is a condition (temperature and relative humidity) whereby of a salt two solid states and its aqueous solution are in equilibrium with each other. By changing the RH or temperature slightly at least one of these phases cannot longer exist. In practice, this triple point is not always a strict transition point. Especially the sulphate hydrates shows that these points sometimes can be neglected. The amount of incongruent melting has strong effects on the hydration/dehydration process.

DISSERTATIONS

-

SCIENTIFIC PUBLICATIONS

-



Prof.dr.ir. GWM Kroesen

Our mission is to study the elementary processes in gas discharges by a mix of theory, modelling, and diagnostics.

A thorough understanding of the intensity and effectivity of elementary processes like ionization, recombination, transport, radiation, excitation, de-excitation, chemical reactions and surface processes enables the group to develop predictive models of a large range of plasmas. The understanding is obtained by a strong interleaved integration of state-of-the-art plasma diagnostics with advanced plasma models. Those models then in turn enable users of the plasmas to optimize the plasma source for their specific application. Over the years, the range of applications the group has worked on has shifted continuously: from plasma etching via lighting to medical applications and many other areas. However, the scientific scope of the group has not shifted: continuously the focus has been with the elementary processes in and the physics of plasmas.

Some applications fade and other applications lure, but plasma physics remains our core.

If you are not familiar with plasma and gas discharge physics, you may wish to consult the Wikipedia page about plasma physics. Alternatively, the applications and techniques sections of this site provide an explanation of the plasma sources and measurement and modelling techniques that are used in our group. If nothing else, the pictures shown there may convince you of the visual beauty of the topic of our research!

PULSED MICROWAVE PLASMAS FOR BETTER CONTROL OF DEPOSITION PROCESSES

PROJECT AIM

In pulsed operation, the microwave plasma will behave completely different from the steady state case. In order to be able to tailor these plasmas to the needs of experimenters and end users, a thorough study will be performed on the behaviour of the plasma both in the on-period and in the off-period of the pulse. Experimental methods include Thomson scattering, Laser induced fluorescence and Optical Emission Spectroscopy. The plasma will also be modelled. We choose to begin with volume averaged models of the discharge chemistry. Later on, these models can be integrated in full 2D models.

PROGRESS

A solid state microwave power supply has been installed to create and study molecular gas plasmas (O₂). Diagnostics on Ar/O₂/SiCl₄ plasmas have been performed by broadband emission spectroscopy. Measurements of the electron and negative ion densities have been performed on the argon and argon-oxygen plasmas by Thomson scattering. The modelling platform PLASIMO now contains a module that is capable of calculating transport coefficients more accurately. Additionally ab initio calculations have been performed on SiCl/SiO/SiO⁺ in order to predict the spectral emission. The construction of a stable 2D model using an O₂/SiCl₄ chemistry is still ongoing work.

DISSERTATIONS

1. Kemaneci E., Modelling of plasmas with complex chemistry: application to microwave deposition reactors.

SCIENTIFIC PUBLICATIONS

1. Carbone, E.A.D. & Nijdam, S. (2014). Ultra-fast pulsed microwave plasma breakdown : evidence of various ignition modes. *Plasma Sources Sci. Technol.* 23 012001 doi:10.1088/0963-0252/23/1/012001.
2. Hübner, S., Carbone, E., Palomares, J. M. and van der Mullen, J. (2014), Afterglow of Argon Plasmas with H₂, O₂, N₂, and CO₂ Admixtures Observed by Thomson Scattering. *Plasma Processes Polym.*, 11: 482–488. doi: 10.1002/ppap.201300190.
3. Kemaneci E., Carbone E., Booth J. P., Graef W., van Dijk J., Kroesen G. (2014), Global (volume-averaged) model of inductively coupled chlorine plasma: Influence of Cl wall recombination and external heating on continuous and pulse-modulated plasmas. *Plasma Sources Sci. Technol.* 23 045002 doi:10.1088/0963-0252/23/4/045002.

PROJECT LEADERS

J van Dijk, S Nijdam, GMW
Kroesen

RESEARCH THEME

Complex dynamics of fluids

PARTICIPANTS

J van Dijk, S Nijdam, GMW
Kroesen, EAD Carbone, EH
Kemaneci, J Beckers, S Hofmann,
JFJ Janssen

COOPERATIONS

DRAKA

FUNDED

STW, DRAKA
University -
FOM -
STW 69 %
NWO Other -
Industry 31 %
TNO -
GTI -
EU -
Scholarships -

START OF THE PROJECT

2010

INFORMATION

S Nijdam
040 247 4342
s.nijdam@tue.nl

PROJECT LEADERS

J van Dijk, KSC Peerenboom

RESEARCH THEME

Complex dynamics of fluids

PARTICIPANTS

P Koelman, S Tadayon-Mousavi,
W Graef, K Peerenboom,
J van Dijk

COOPERATIONS

DIFFER, Utwente, Alliander

FUNDED

| | |
|--------------|-------|
| STW | |
| University | - |
| FOM | - |
| STW | 100 % |
| NWO Other | - |
| Industry | - |
| TNO | - |
| GTI | - |
| EU | - |
| Scholarships | - |

START OF THE PROJECT

2014

INFORMATION

Jvan Dijk
040 247 4871
j.v.dijk@tue.nl
<http://plasimo.phys.tue.nl>

PROJECT AIM

The project aim is the development of an integral route towards energy-efficient and CO₂ neutral production of Solar Fuels combining plasma and separation technology. In the plasma conversion step a novel concept is introduced for the reduction of CO₂ into CO and O₂. In this concept, more selective rovibrational excitation of CO₂ will be achieved by means of spatial variation and time modulation of the plasma power in an expanding microwave plasma. The importance of the supersonic expansion for the efficient dissociation of CO₂ will be investigated.

PROGRESS

The project proposal was granted in the summer of 2014. Two PhD students and a Postdoc have been hired. The project will start in March 2015.

DISSERTATIONS

-

SCIENTIFIC PUBLICATIONS

-



A picture of a flowing microwave-induced plasma in CO₂. Taken from: <http://differ.nl>.

PHYSICS AND CHEMISTRY OF PLASMAS FOR WOUND HEALING

PROJECT AIM

This project concerns the characterization of cold atmospheric pressure plasmas developed for use in medicine. Its aim is the determination of radical densities and fluxes in the effluent of an RF plasma jet, time and space resolved, and the characterization of oxygen chemistry that takes place in the effluent. The characterization of flow dynamics is essential for understanding the admixing of atmospheric air into the plasma effluent and therefore the chemistry.

PROGRESS

The project is in its final stages. In the last year the focus was on the time-resolved imaging of the flow patterns of the effluent of the plasma jet and on time-resolved measurements of ozone densities. One paper has been submitted in 2014 and published in 2015 concerning flow dynamics and this work has been presented at an international conference (67th Annual Gaseous Electronics Conference, Nov.2014).

DISSERTATIONS

-

SCIENTIFIC PUBLICATIONS

1. S Zhang et al, The effect of collisional quenching of the O 3p 3PJ state on the determination of the spatial distribution of the atomic oxygen density in an APPJ operating in ambient air by TALIF, 2014 Plasma Sources Sci. Technol. 23 025012.
2. S Iseni et al, Nitric oxide density distributions in the effluent of an RF argon APPJ: effect of gas flow rate and substrate, 2014 New J. Phys. 16 123011.

PROJECTLEADERS

GWM Kroesen

RESEARCHTHEME

Complex dynamics of fluids

PARTICIPANTS

S Zhang, EM van Veldhuizen,
A Sobota

COOPERATIONS

-

FUNDED

Chinese Scholarship Council
Dutch Technology Foundation (STW)
University -
FOM -
STW 10 %
NWO Other -
Industry -
TNO -
GTI -
EU -
Scholarships 90 %

START OF THE PROJECT

2011

INFORMATION

A Sobota
040 247 4340
a.sobota@tue.nl



Prof.dr.ir. RJM Bastiaans



Prof.dr. LPH de Goey



Prof.dr. B Johansson

The goal of the research programme of the 'Combustion Technology Group' is to gain insight in and knowledge on reacting flows in order to develop new and improve existing models of combustion systems. The models are used to guide new developments in the struggle to come to more efficient and clean conversion systems of fossil and sustainable fuels for a sustainable society. The knowledge and models developed are based on thorough physical and chemical understanding of the processes. This means that the gap between fundament and application has to be bridged continuously by transforming models describing physical/chemical behaviour on the smallest scales to models for the macroscopic scale of the full system. The knowledge is based on 'generic' theoretical and numerical insights for the propagation and structure of idealised flames and their interaction with acoustic waves, turbulent structures and inert/reacting surfaces. Most models for the combustion chemistry are based on a combination of the so-called laminar flamelet concept and chemical reduction methods leading to new techniques like FGM.

There is also a close entanglement of theoretical/numerical and experimental research. Available diagnostic techniques are e.g. flame visualisation, absorption techniques, LDV, PIV, LIF and Rayleigh scattering. Validation with the available laser-diagnostic measurement systems in the laboratory and real applications is carried out to disentangle the processes taking place on the various length and time scales. These measurements are carried out in flat (non-)adiabatic flames stabilised on the Heat Flux burner, laminar flames on Bunsen-type burners, flat turbulent flames on a weak-swirl burner, biomass grid, tube and bed reactors, optically-accessible combustion vessels and optically-accessible engines. Application areas are: small-scale laminar combustion systems, combustion of bio-fuels, engines and gas turbines. The application area of combustion engines is of particular interest.

NUMERICAL AND EXPERIMENTAL STUDY OF THERMO-ACOUSTICS OF DOMESTIC BURNER WITH HEAT EXCHANGER

PROJECT AIM

The goal of the project is to investigate the interaction between a burner and a heat exchanger looking from a thermo-acoustic and hydrodynamic point of view. This goal is thought to be achieved by both laboratory and numerical experiments. A laboratory with basic test setups is available to measure the relation between acoustic pressure and heat release. On the numerical front, simple premixed flames are going to be modelled to study this relation. This will be taken as a starting point to research the interaction with a heat exchanger. Finally, design rules need to be defined in order to create this combination in a shorter time span. This is thought to be achieved by using statistic tools.

PROGRESS

In the numerical front, the CFD model is developed for inclusion of heat exchanger. Extensive combustion verifications have been performed to ensure correct flame speeds and thermoacoustic properties. Further modifications and verifications of the model with regard to previous studies are in progress. The idea of obtaining a total transfer function for the system via it's components transfer functions has been developed. Currently simplified systems are under investigation to check the possibility of this theory. In this regards, a joint study with Technische Universität München has been planned. The experimental setup for the same case has been designed and manufactured in order to provide physical data along with the simulations. The major problems of the setup have been resolved and it will be ready for starting experiments by the end of 2014. Below are some pictures of simulations and the experimental setup.

DISSERTATIONS

-

SCIENTIFIC PUBLICATIONS

1. Hosseini, N., Kornilov, V., Teerling, O.J., Arteaga, I.L., de Goeij, L.P.H., "Development of a Numerical Model for Obtaining Flame Transfer Function in a Simplified Slit Burner with Heat Exchanger", The 21st International Congress on Sound and Vibration, 13-17 July 2014, Beijing, China.
2. Hosseini, N., Kornilov, V., Teerling, O.J., Arteaga, I.L., de Goeij, L.P.H., "Numerical Investigations of the Response of a Simplified Burner-heat exchanger System to Inlet Velocity Excitations", Combura'14 Combustion Research and Application, 8-9 October 2014, Soesterberg, The Netherlands.

PROJECT LEADERS

LPH de Goeij, V Kornilov, J Teerling, I Lopez

RESEARCH THEME

Complex dynamics of fluids

PARTICIPANTS

N Hosseini

COOPERATIONS

Bekaert Combustion Technology
Technische Universität München
Keele University

FUNDED

STW, EC, Bekaert Combustion Technology
University -
FOM -
STW 7 %
NWO Other -
Industry 18 %
TNO -
GTI -
EU 75 %
Scholarships -

START OF THE PROJECT

2013

INFORMATION

N Hosseini
06 44266732
n.hosseini@tue.nl
www.scm.keele.ac.uk/Tango/tango-network-research-task-3-5

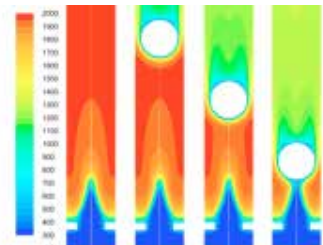
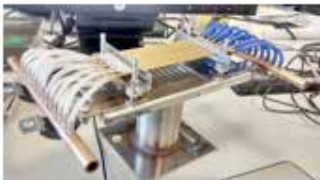

TRACKING JOULES: FLAME-WALL INTERACTION IN DIESEL SPRAY COMBUSTION

PROJECT LEADERS

LPH de Goeij, NJ Dam, LMT Somers

RESEARCH THEME

Complex dynamics of fluids

PARTICIPANTS

NCJ Maes

COOPERATIONS

Fiat Powertrain Technologies.

FUNDED

University, Fiat Powertrain Technologies.

University 66,6 %

FOM -

STW -

NWO Other -

Industry 33,3 %

TNO -

GTI -

EU -

Scholarships -

START OF THE PROJECT

2014

INFORMATION

NCJ Maes

040 247 2877

n.c.j.maes@tue.nl

www.combustion.tue.nl

PROJECT AIM

In a collaboration with Fiat Powertrain Technologies, the effect of flame-wall interaction is studied in detail using optical diagnostic techniques and temperature measurements in a constant volume vessel. The higher goal is to design a completely new, heavy duty engine based on model optimization. In order to achieve reliable and predictive models, however, it is essential to perform fundamental and reproducible experiments at relevant conditions to validate the correctness and sensitivity of such numerical efforts.

PROGRESS

In order to study flame wall interaction at heavy loads, several adjustments to the existing constant volume vessel are required and the conditions need to be validated.

- A dedicated, heavy duty single-hole injector has been installed.

- An rpm-regulated electromotor is mounted to a magnetic coupling to ensure reliable mixing.

- Thermocouple measurements have been prepared to characterize the internal temperature during experiments.

- New valves are being installed at diagonal locations of the vessel to allow for higher densities and to obtain additional space for a wall insert with thermocouple probes.

- Test measurements to characterize the liquid fuel have been performed using a high-speed light extinction technique.

DISSERTATIONS

-

SCIENTIFIC PUBLICATIONS

-

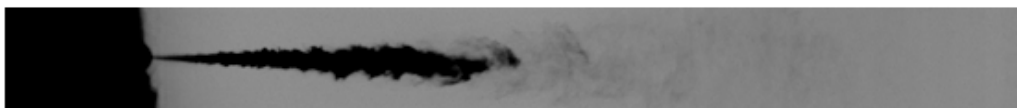

PROJECT AIM

The focus of this project is on MILD combustion, which is characterized by a high degree of preheating and dilution of the reactants and offers the possibility of a sustainable, near emission-free energy production. The project encompasses a multi-scale approach that starts with an exploration of the small-scale fundamental processes causing the outstanding properties of MILD combustion. This fundamental knowledge is then translated via numerical studies of lab-scale burners into design tools for large-scale industrial combustion devices. To investigate the reaction structures that arise in MILD combustion, high-fidelity numerical models will be employed.

PROGRESS

DNS of the Adelaide jet-in-hot-coflow (JHC) were performed. It was found that preferential diffusion and heat loss effects are crucial, especially in predicting ignition delay. It was observed that the flame formation is via autoignition, rather than flame spreading. RANS of the Delft JHC was conducted with FGM and EDC options for turbulence-chemistry interaction. FGM performance is better in terms of lift-off height prediction. A 1D analysis of biogas combustion in MILD regime was performed for different mixtures of CO₂ and CH₄. FGM chemistry tables for these cases were constructed and validated in 1D flames. The influence of automated selection of the progress variable on the prediction of 1D flames was investigated. The FGM tables are used in LES of JHC flames with CO₂ dilution of natural gas.

DISSERTATIONS

-

SCIENTIFIC PUBLICATIONS

1. M.U. Göktolga, J.A. van Oijen, L.P.H. de Goeij, Comparison of Autoignition Characteristics of 2D and 3D Mixing Layers, FCE 2014, Istanbul, January 2014.
2. M.U. Göktolga, J.A. van Oijen, L.P.H. de Goeij, DNS of Auto-igniting Mixing Layers and Investigation of Effects of Temperature Profile and Dimension, Burgersdag 2014.
3. G. Sorrentino, P. Sabia, M. de Joannon, R. Ragucci, A. Cavaliere, M.U. Göktolga, J. van Oijen, P. de Goeij Development of a novel cyclonic flow combustion chamber for achieving MILD/Flameless Combustion, ICCEU12, Lancaster, UK.

PROJECT LEADERS

JA van Oijen

RESEARCH THEME

Complex dynamics of fluids

PARTICIPANTS

FE Hernandez Perez, MU Göktolga, A. Vasavan, JA van Oijen

COOPERATIONS

-

FUNDED

| | |
|--------------|-------|
| NWO (VIDI) | |
| University | - |
| FOM | - |
| STW | - |
| NWO Other | 100 % |
| Industry | - |
| TNO | - |
| GTI | - |
| EU | - |
| Scholarships | - |

START OF THE PROJECT

2010

INFORMATION

JA van Oijen
 040 247 3133
 j.a.v.oijen@tue.nl
 www.tue.nl/combustion

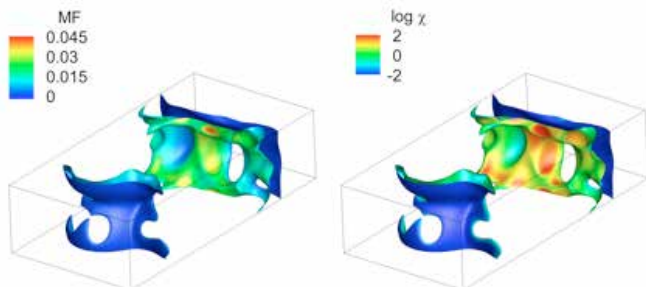

Mixture fraction and scalar dissipation contours on $Y_h = 2 \times 10^{-5}$ iso-surface from DNS calculations

CFD MODELING FOR THE OPTIMIZATION OF A FLAME IONIZATION SENSOR

PROJECT LEADERS

JA van Oijen

RESEARCH THEME

Complex dynamics of fluids

PARTICIPANTS

JA van Oijen, N Speelman

COOPERATIONS

-

FUNDED

Bosch Thermotechniek BV

University -

FOM -

STW -

NWO Other -

Industry 100 %

TNO -

GTI -

EU -

Scholarships -

START OF THE PROJECT

2010

INFORMATION

JA van Oijen

040 247 3133

j.a.v.oijen@tue.nl

www.tue.nl/combustion

PROJECT AIM

The purpose of this research is to develop a combustion control and diagnostics sensor based on flame ionization for condensing boiler applications. The flame ionization sensor measures the electrical conduction of the charged species generated during the combustion process to detect flashback and combustion instabilities, and to monitor equivalence ratio. In particular, the focus is on developing models to integrate the electric field emanating from the electrode with the lean premixed combustion process and ion reaction/transport submodels to simulate the electrode test results and optimize its position and shape.

PROGRESS

During the previous year the numerical model was finalized and it was validated against experimental observations. It was found that the model performed well qualitatively and that all features of the voltage-current characteristic were represented by the model. To improve the quantitative agreement, the chemical mechanism was optimized. Using the optimized mechanism excellent agreement was found for a wide range of conditions (see Figure). The model was furthermore used to simulate time-dependent flames in AC electric fields, which were studied experimentally. The observed unsteady effects were reproduced by the model.

DISSERTATIONS

-

SCIENTIFIC PUBLICATIONS

-

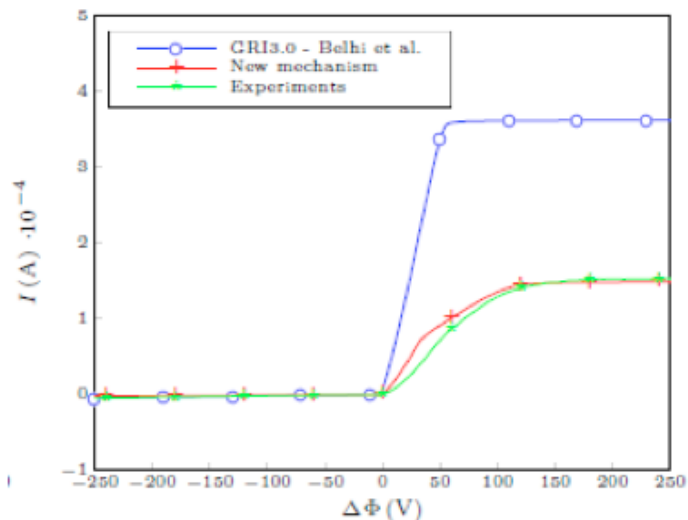

Voltage-current characteristic for a flat premixed methane-air flame

ADVANCED LOW NO_x FLEXIBLE FUEL GAS TURBINE COMBUSTION, AERO AND STATIONARY

PROJECT AIM

In the current project detailed knowledge for modeling of combustion with alternative fuels will be developed. This is done by means of detailed descriptions in the framework of Computational Fluid Dynamics (CFD). The ultimate goal is to predict the combustion process of gas turbines, including complex physical real fuel phenomena (NO_x, preferential diffusion, thermo diffusive effects, etc.). To that end the promising flamelet generated manifolds (FGM) technique will be extended in this project. The technique is developed in its basic form at TU/e and has been continuously tested and extended to more general situations over the last years.

PROGRESS

Implementation of mixture fraction inclusion in the tool FGM construction. Ansys-CFX implementation of this technique for the 3D manifold. Testing in a simple 2D geometry. Inclusion of turbulence effects in the 5D FGM construction tool. Testing and validation on swirled gas turbine model combustor. Writing thesis.

DISSERTATIONS

1. Donini, A. (2014). PhD thesis. Advanced turbulent combustion modeling for gas turbine application. Eindhoven: Technische Universiteit Eindhoven. ((Co-) promot.: prof.dr. L.P.H. de Goey, dr.ir. R.J.M. Bastiaans & dr.ir. J.A. van Oijen).
2. Mukhopadhyay, S. (2014). Modeling turbulent combustion using spatially filtered flamelets. Eindhoven: Technische Universiteit Eindhoven. ((Co-) promot.: prof.dr. L.P.H. de Goey, dr.ir. R.J.M. Bastiaans & dr.ir. J.A. van Oijen).

SCIENTIFIC PUBLICATIONS

1. Donini, A., Bastiaans, R.J.M., Oijen, J.A. van & Goey, L.P.H. de (2014). Numerical simulations of a turbulent high-pressure premixed cooled jet flame with the flamelet generated manifolds technique. *Journal of Engineering for Gas Turbines and Power* : Transactions of the ASME, 137(7), 071501-1/8.
2. Donini, A., Bastiaans, R.J.M., Oijen, J.A. van & Goey, L.P.H. de (2014). Differential diffusion effects inclusion with flamelet generated manifold for the modeling of stratified premixed cooled flames. *Proceedings of the Combustion Institute*,
3. Donini, A., Bastiaans, R.J.M., Oijen, J.A. van & Goey, L.P.H. de (2014). The application of flamelet-generated manifold in the modeling of partially premixed cooled flames. *Conference Paper* : Proceedings of the 15th International Symposium on Transport Phenomena and Dynamics of Rotating Machinery (ISROMAC 15), 24-28 February 2014, USA,
4. Donini, A., Bastiaans, R.J.M., Oijen, J.A. van & Goey, L.P.H. de (2014). The application of flamelet-generated manifold in the modeling of stratified premixed cooled flames. *Conference Paper* : Proceedings of the ASME Turbo Expo 2014: Turbine Technical Conference and Exposition (GT2014), June 16-20, 2014, Dusseldorf, Germany, (pp. 26210). ASME.

PROJECT LEADERS

RJM Bastiaans, LPH de Goey,
JA van Oijen

RESEARCH THEME

Mathematical and computational methods for fluid flow analysis

PARTICIPANTS

Andrea Donini, Sudipto
Mukhopadhyay

COOPERATIONS

Siemens Power Generation (SPG)
Rolls Royce Deutschland (RRD)

FUNDED

University, STW, SPG, RRD
University -
FOM -
STW 75 %
NWO Other -
Industry 25 %
TNO -
GTI -
EU -
Scholarships -

START OF THE PROJECT

2010

INFORMATION

RJM Bastiaans
040 247 4836
r.j.m.bastiaans@tue.nl
www.tue.nl/combustion
www.fgm-combustion.org

MOBILISING HEAVY HYDROCARBONS

PROJECT LEADERS

M Golombok, MD Boot, LPH de Goey

RESEARCH THEME

Complex structures of fluids

PARTICIPANTS

M Cuijpers, M Golombok, MD Boot, J Hasker, F Seegers, M Willekens, J van Santvoort

COOPERATIONS

Shell

FUNDED

| | |
|--------------|-------|
| Shell | |
| University | - |
| FOM | - |
| STW | - |
| NWO Other | - |
| Industry | 100 % |
| TNO | - |
| GTI | - |
| EU | - |
| Scholarships | - |

START OF THE PROJECT

2014

INFORMATION

M Cuijpers
040 247 3591
m.c.m.cuijpers@tue.nl
www.combustion.tue.nl

PROJECT AIM

Different resources are global available, Heavy oil, Shale oil and Lignin, all containing a high viscosity and therefore hard to recover, transport and process. The use of subcritical water, at the right conditions, will crack or dissolve these resources. Resulting in a decrease in viscosity and a increase in H/C ratio, improving the quality and the workability of the resources.

PROGRESS

The primary interest for subcritical processing described here is to reduce the viscosity, Figure 1. For surface processing of oil sands, this improves transportability in pipeline flow. In a more distant projected application in the subsurface (either for bituminous or for kerogenic oils where the rock permeability permits), viscosity reduction improves mobility for subsequent oil displacement.

DISSERTATIONS

-

SCIENTIFIC PUBLICATIONS

-

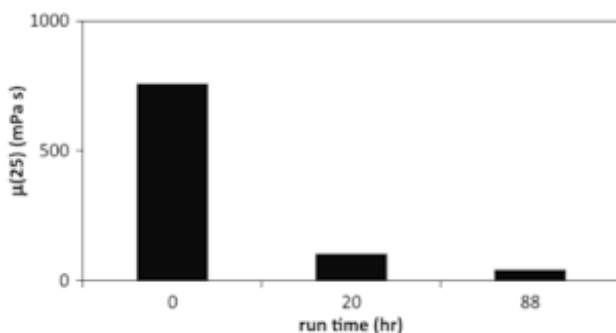

Viscosity as function of process time

PROJECT AIM

Diesel engines lose valuable efficiency points because of the relatively long burn-out phase. To study this in more detail, sophisticated laser diagnostic techniques will be developed and applied. The goal is to provide an improved fundamental understanding of the fate of this late-burning fuel to improve engine efficiency by more economic use of the injected fuel, and to complete the last steps towards a full numerical engine combustion model (other PhD).

PROGRESS

The fuel-air mixing prior to combustion is essential for the combustion event itself. Throughout the last year, the mixing process has been tracked by fuel-tracer laser-induced fluorescence. The effects of injection strategy and fuel split were investigated. Some of the first results are promising, but more experiments are required to capture the true spray-all (i.e. piston) effects. Upcoming experiments will not only track fuel clouds, but also emission formation regions (CO, soot).

DISSERTATIONS

-

SCIENTIFIC PUBLICATIONS

1. Leermakers, C.A.J., Bakker, P.C., Nijssen, B.C.W., Somers, L.M.T. & Johansson, B.H. (2014). Low octane fuel composition effects on the load range capability of partially premixed combustion. *Fuel*, 135(1), 210-222.
2. Bakker, P.C., De Abreu Goes, J.E., Somers, L.M.T. & Johansson, B.H. (2014). Characterization of low load PPC operation using RON70 fuels. SAE Technical Paper 2014-01-1304.

PROJECT LEADERS

LMT Somers, NJ Dam

RESEARCH THEME

Complex dynamics of fluids

PARTICIPANTS

PC Bakker, HY Akargün, LMT Somers, NJ Dam, BH Johansson

COOPERATIONS

DAF Trucks, TNO, Delphi, Shell Global Solutions

FUNDED

| | |
|-----------------------------|------|
| STW, Shell Global Solutions | |
| University | - |
| FOM | - |
| STW | 50 % |
| NWO Other | - |
| Industry | 50 % |
| TNO | - |
| GTI | - |
| EU | - |
| Scholarships | - |

START OF THE PROJECT

2013

INFORMATION

PC Bakker
040 247 5995
p.c.bakker@tue.nl
www.tue.nl/combustion

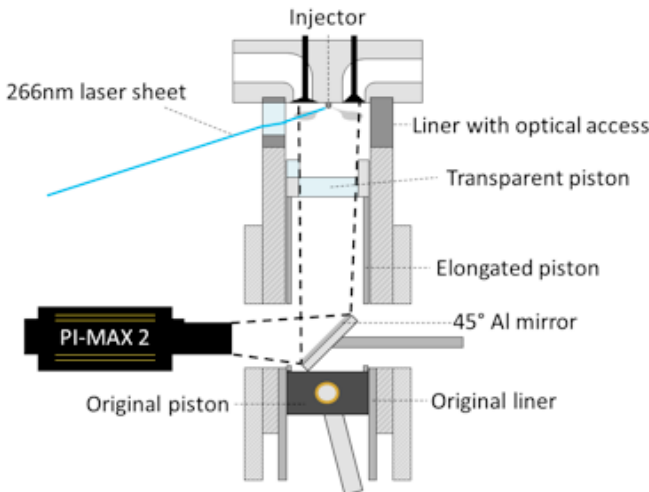

PROJECT LEADERS

LPH de Goeij

RESEARCH THEME

Mathematical and computational methods for fluid flow analysis

PARTICIPANTS

B Akkurt, B Somers, F Willems

COOPERATIONS

DAF Trucks, Sensata, TNO, Delphi

FUNDED

| | |
|---|--------|
| STW, DAF, Sensata, TNO, Delphi University | - |
| FOM | - |
| STW | 63,5 % |
| NWO Other | - |
| Industry | 17 % |
| TNO | 19,5 % |
| GTI | - |
| EU | - |
| Scholarships | - |

START OF THE PROJECT

2009

INFORMATION

Thiago Cardoso de Souza
040 247 3731
t.cardoso.de.souza@tue.nl
www.tue.nl/combustion

PROJECT AIM

This research project focusses on the development of new modelling for high EGR diesel combustion concepts with multi-phase fueling systems, which is seen as an essential step towards future RCCI concepts. The CFD-FGM model, which will be extended for multi-pulse injection strategies, will be validated with experimental data.

PROGRESS

Literature researches about combustion, FGM, combustion modelling & CFD integration are done. Data generated with Chem1d for spray A conditions. Currently, 2D manifold generation and validation of it with chem1d is being performed.

DISSERTATIONS

-

SCIENTIFIC PUBLICATIONS

-

NUMERICAL RESEARCH OF LEAN COMBUSTION IN MICRO GAS TURBINE

PROJECT AIM

The aim of this project is to study the fluid and combustion in micro gas turbine to reduce NOx emission, improve combustion status and increase efficiency. Optimal injection location will be found to make air and gas mixed well and lean combustion in small scale combustor will be developed.

PROGRESS

There are seven vanes as well as seven injection holes on the swirler. As the angle between each two holes is 51.43 degree, four cases of different injection positions have been studied. The results show that there are clear differences when changing the injection positions. More cases have been planned and will be done in a few weeks. A criteria method is expected to be developed. Meanwhile in order to investigate the different combustion models in Fluent, especially the partially premixed combustion model, some 2D flame has been studied. However, because of the lack of experimental data, the Sandia Flame D is finally used as validation reference.

DISSERTATIONS

-

SCIENTIFIC PUBLICATIONS

-

PROJECT LEADERS

RJM Bastiaans, LPH de Goeij

RESEARCH THEME

Complex dynamics of fluids

PARTICIPANTS

Y Zhao, V Kornilov, RJM Bastiaans, LPH de Goeij

COOPERATIONS

-

FUNDED

- China Scholarship Council (CSC) University -
- FOM -
- STW -
- NWO Other -
- Industry -
- TNO -
- GTI -
- EU -
- Scholarships 100 %

START OF THE PROJECT

2012

INFORMATION

Y Zhao
040 247 2877
Y.Zhao1@tue.nl
www.tue.nl/combustion

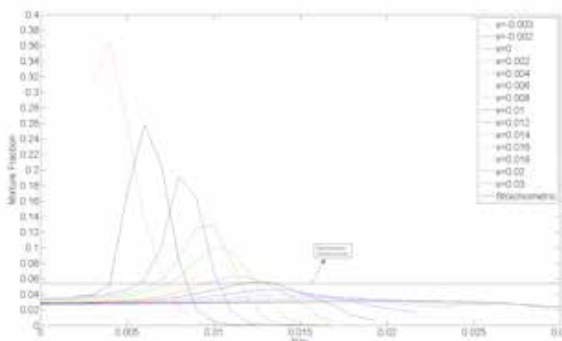
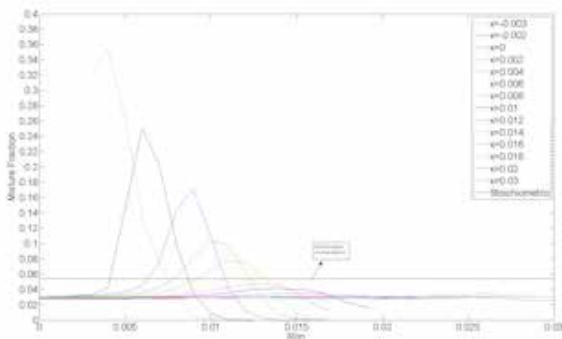

PROJECT LEADERS

V Kornilov, J van Oijen, P de Goey

RESEARCH THEME

Complex dynamics of fluids

PARTICIPANTS

A Elkholy

COOPERATIONS

CWI's research group (Ute Ebert)
Physics department in TUE (Sander Nijdam)

FUNDED

Egyptian government
University -
FOM -
STW -
NWO Other -
Industry -
TNO -
GTI -
EU -
Scholarships 100 %

START OF THE PROJECT

2014

INFORMATION

A Elkholy
040 247 3621
A.Elkholy@tue.nl
www.combustion.tue.nl

PROJECT AIM

The aim of the project is to investigate experimentally low temperature plasma-flame interaction for CH₄ premixed flame in a flat flame burner with a dielectric barrier discharge (DBD) Plasma technique. We desire to investigate the effect of RF (radio frequency) plasma on flame stabilization, emissions, CH₄ oxidation rate, radical and ion formation and their effect on flame propagation speed.

PROGRESS

- Design and construction of CH₄ flat flame burner.
- Design and construction of dielectric barrier discharge (DBD) plasma generator which consisting of disk electrodes , pulse generator, signal amplifier and oscilloscope.
- Studying different holes patterns to get the suitable plasma discharge inside/around the holes.

DISSERTATIONS

-

SCIENTIFIC PUBLICATIONS

-

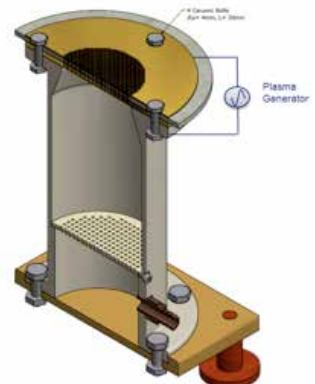

FATE OF FORGOTTEN FUEL

PROJECT AIM

Investigation of the burn-out phase: the late combustion of “forgotten fuel”, left-overs from the main heat release in the classical diesel combustion (CDC) regime. Numerical part of the project will focus on testing and extending the Flamelet-Generated Manifold (FGM) approach towards the burn-out phase. For that purpose; FGM method will be applied to Large-Eddy Simulation (LES) and validation studies will be performed for spray A and D5 optical engine cases.

PROGRESS

Literature in the field of theoretical & numerical combustion and FGM are studied. Detailed chemistry 1D flame solutions are obtained for ECN spray A like condition (for various temperature and strain rate values) by using chem1d. FGM's are constructed for spray A case and validation of reduced chemistry solutions against detailed chemistry ones are partially performed for 1-D case.

DISSERTATIONS

-

SCIENTIFIC PUBLICATIONS

-

PROJECT LEADERS

LMT Somers, NJ Dam, LPH de Goeij

RESEARCH THEME

Mathematical and computational methods for fluid flow analysis

PARTICIPANTS

HY Akargun

COOPERATIONS

SHELL, DAF, TNO, Lund University, Imperial College, Sandia National Laboratories, IFP-EN

FUNDED

| | |
|--------------|------|
| STW, SHELL | |
| University | - |
| FOM | - |
| STW | 51 % |
| NWO Other | - |
| Industry | 49 % |
| TNO | - |
| GTI | - |
| EU | - |
| Scholarships | - |

START OF THE PROJECT

2014

INFORMATION

HYt Akargun
06 3036 89 17
h.y.akargun@tue.nl
www.combustion.tue.nl

DEVELOPMENT OF RELIABLE EMISSION AND ATOMIZATION MODELS FOR COMBUSTOR DESIGN

PROJECT LEADERS

JA van Oijen

RESEARCH THEME

Mathematical and computational methods for fluid flow analysis

PARTICIPANTS

D Efimov

COOPERATIONS

Rheinisch-Westfälische Technische Hochschule Aachen. Karlsruher Institut für Technologie. Imperial College of Science, Technology and Medicine.

FUNDED

| | |
|----------------|------|
| EU, University | |
| University | 25 % |
| FOM | - |
| STW | - |
| NWO Other | - |
| Industry | - |
| TNO | - |
| GTI | - |
| EU | 75 % |
| Scholarships | - |

START OF THE PROJECT

2013

INFORMATION

JA van Oijen
040 247 3133
j.a.v.oijen@tue.nl
www.tue.nl/combustion

PROJECT AIM

Aim of this project is to develop an accurate and reliable computational tool for prediction of emissions in a lean burn combustion systems for civil aerospace applications. Within this project, the research carried out by TU/e will concentrate on the chemistry reduction method Flamelet-Generated

Manifold (FGM), which is intended to reduce the computational cost of the complex chemistry models for application in CFD codes. Improved flamelet tabulation techniques are to be developed focusing on accurate prediction of CO, UHC, NO_x and soot emissions from gas turbine combustors.

PROGRESS

Simulations of 1D flames including isentropic expansion in the post flame zone (process encountered in gas turbine stator) have been performed with a detailed reaction mechanism. An FGM tabulated chemistry model, utilizing enthalpy and pressure as additional controlling variables and a second reaction controlling variable, has been validated against aforementioned detailed chemistry cases. CO and NO predictions improved significantly using a second reaction variable.

DISSERTATIONS

-

SCIENTIFIC PUBLICATIONS

-

EFFECTS OF PRESSURE ON COMBUSTION CHARACTERISTICS OF CELLULAR HYDROGEN FLAMES

PROJECT AIM

Hydrogen is expected to play an important role in future energy production, especially for the fuel of gas turbine engines. However, there are gaps in the fundamental understanding of hydrogen combustion characteristics at normal and elevated pressures due to the high diffusivity, high reactivity of hydrogen. The aim of the project is to investigate the combustion characteristics of cellular hydrogen flames at elevated pressures.

PROGRESS

1. 2D laminar freely-propagating flames of hydrogen/air mixtures were simulated at elevated pressure and temperature.
2. High pressure flame ball setup is under development.

DISSERTATIONS

-

SCIENTIFIC PUBLICATIONS

-

PROJECT LEADERS

RJM Bastiaans

RESEARCH THEME

Complex dynamics of fluids

PARTICIPANTS

Z Zhou

COOPERATIONS

-

FUNDED

Chinese Scholarship council

University -

FOM -

STW -

NWO Other -

Industry -

TNO -

GTI -

EU -

Scholarships 100 %

START OF THE PROJECT

2013

INFORMATION

Z Zhou

Z.Zhou1@tue.nl

www.tue.nl/combustion

ALTAS PROJECT: ADVANCED LOW NOX FLEXIBLE FUEL GAS TURBINE COMBUSTION, AERO AND STATIONARY

PROJECT LEADERS

RJM Bastiaans, LPH de Goey, JA van Oijen

RESEARCH THEME

Mathematical and computational methods for fluid flow analysis

PARTICIPANTS

E Abtahizadeh, A Donini

COOPERATIONS

Siemens Power Generation (SPG)
Rolls Royce Deutschland (RRD)

FUNDED

STW, Siemens Power Generation (SPG), Rolls Royce Deutschland (RRD)

| | |
|--------------|------|
| University | - |
| FOM | - |
| STW | 75 % |
| NWO Other | - |
| Industry | 25 % |
| TNO | - |
| GTI | - |
| EU | - |
| Scholarships | - |

START OF THE PROJECT

2010

INFORMATION

RJM Bastiaans
040 247 4836
r.j.m.bastiaans@tue.nl
www.tue.nl/combustion

PROJECT AIM

In the current project detailed knowledge for modeling of combustion with alternative fuels will be developed. This is done by means of detailed descriptions in the framework of Computational Fluid Dynamics (CFD). The ultimate goal is to predict the combustion process of gas turbines, including complex physical real fuel phenomena (NOx, preferential diffusion, thermo diffusive effects, etc.). To that end the promising flamelet generated manifolds (FGM) technique will be extended in this project. The technique is developed in its basic form at TU/e and has been continuously tested and extended to more general situations over the last years.

PROGRESS

Autoignition of non-premixed flames has been investigated in gas-turbine relevant conditions where methane based fuels have been enriched with various amounts of H₂. For this purpose, Direct Numerical Simulation (DNS) of turbulent mixing layers has been performed by using detailed chemistry. Afterwards, FGM chemistry has been implemented in these calculations and validated against detailed chemistry results. Flame structure has been analyzed and subsequently, Sub-Grid Scale (SGS) models have been developed for LES calculations.

DISSERTATIONS

1. S.E. Abtahizadeh, Numerical study of Mild combustion from laminar flames to Large Eddy Simulation of turbulent flames with Flamelet Generated Manifolds, PhD thesis, Eindhoven University of Technology (2014).

SCIENTIFIC PUBLICATIONS

1. S.E. Abtahizadeh, J.A. van Oijen, R.J.M. Bastiaans, L.P.H. de Goey, LES of turbulent lifted CH₄/H₂ flames using a novel FGM-PDF model, Bulletin of the 67th American Physical Society - Division of Fluid Dynamics (APS-DFD 2014), 23 - 25 November 2014, San Francisco, CA, USA.
2. S.E. Abtahizadeh, J.A. van Oijen, R.J.M. Bastiaans, L.P.H. de Goey, LES of turbulent lifted CH₄/H₂ flames: Preferential diffusion effects, 52nd Symposium (Japanese) on Combustion, 3-5 December, 2014, Okayama, Japan.
3. S.E. Abtahizadeh, J.A. van Oijen, R.J.M. Bastiaans, L.P.H. de Goey, LES of Delft Jet-in-Hot Coflow burner with hydrogen enriched mixtures, Proceedings of the Combustion Research and Application (COMBURA 2014), 8 - 9 October 2014, Soesterberg, The Netherlands.

Counters of temperature field in 3D DNS computations

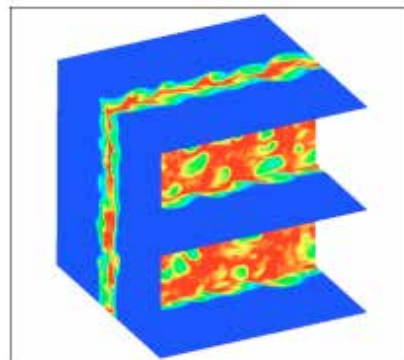

BIOMASS TO BIOFUELS

PROJECT AIM

We reverse engineer, from the engine's perspective, which compounds should ideally be added to conventional fossil fuels to arrive at a more favorable overall engine performance (i.e. in terms of fuel economy and emissions). Second, a production route from biomass should be developed to produce these desired compounds from biomass. This project builds further on existing knowledge that so-called cyclic oxygenates should be targeted, specifically from lignin, a renewable waste-stream available in large volumes in the paper industry.

PROGRESS

Tested chosen oxygenate fuels on SI engine, to study their knock resistance property and the engine performance. Measured oxygenate fuels' ignition delay time by means of IQT (Ignition Quality Tester) at NREL (USA) to further study their ignition quality.

DISSERTATIONS

-

SCIENTIFIC PUBLICATIONS

-

PROJECT LEADERS

LPH de Goey, MD Boot

RESEARCH THEME

Complex dynamics of fluids

PARTICIPANTS

M Tian

COOPERATIONS

-

FUNDED

Scholarship from China

University -

FOM -

STW -

NWO Other -

Industry 100 %

TNO -

GTI -

EU -

Scholarships -

START OF THE PROJECT

2012

INFORMATION

M Tian

m.tian@tue.nl

ULTRA EFFICIENT CLEAN COMBUSTION CONCEPTS AND THEIR FUEL APPETITE

PROJECT LEADERS

LPH de Goeij, LMT Somers

RESEARCH THEME

Complex dynamics of fluids

PARTICIPANTS

S Wang

COOPERATIONS

-

FUNDED

China Scholarship Council

University -

FOM -

STW -

NWO Other -

Industry -

TNO -

GTI -

EU -

Scholarships 100 %

START OF THE PROJECT

2013

INFORMATION

S Wang

040 247 5995

S.Wang@tue.nl

www.tue.nl/combustion

PROJECT AIM

A mandatory target has been set for the European transport sector to use 10% renewable energy by the year 2020. This can be implemented through blending renewable fuels with traditional fuels or through using renewable fuels alone. Our goal is to conduct an intensive study on Low Temperature Combustion (LTC) using various alternative fuels, like ethanol and butanol, to investigate the effects of different fuels' properties on particulate number concentrations and size distributions. In the meantime, make sure these fuels can meet the Euro VI smoke emissions standard as well as maintain high thermal efficiency.

PROGRESS

The goal of LTC is to lower combustion temperatures to advantageously alter the chemistry of NO_x and soot formation. The amount of soot and NO_x emissions emitted from an engine is dependent on both in-cylinder temperature and mixing of fuel and air. A correct combination of EGR rate and air-excess ratio controls the in-cylinder temperature, and fuels with higher research octane number (RON) are supposed to provide longer ignition delay which can enhance the mixing of fuel and air. Experiments which aim to investigate the sensitivity of the combustion parameters and particulate emissions to changes in EGR rate and air-excess ratio for the fuels of RON70 have been done.

DISSERTATIONS

-

SCIENTIFIC PUBLICATIONS

1. Wang, S., Bakker, P.C., De Visser, A.J.M. & Somers, L.M.T. (2014). Effect of air-excess on blends of RON70 partially premixed combustion. Proceedings SPEIC14 – Towards Sustainable Combustion, November 19-21, 2014, Lisboa, Portugal, (pp. 1-8).

Particulate concentration and size distribution of Diesel under different inlet pressures

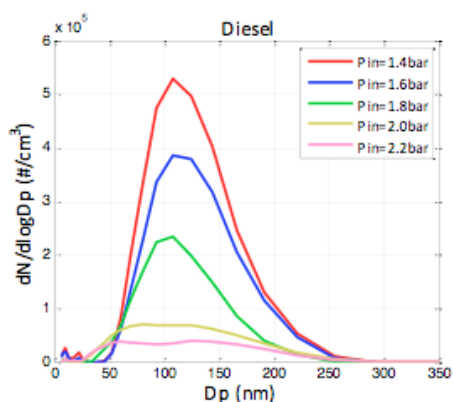



Prof.dr. JGM Kuerten

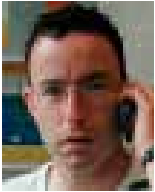

Prof.dr. M Golombok

The programme of the group covers theoretical, numerical and experimental research on selected subjects in process technology. The subjects range from fundamentals to applications. The aims are to contribute to scientific issues relevant to the field, to develop tools for applying scientific results on practical cases and to design machinery and apparatus using these results.

Many research activities are carried out in co-operation with and with support from industry.

THE SUBJECTS OF RESEARCH ARE:

1. STOCHASTIC PROCESSES AND TURBULENCE

The stochastic process of turbulence is a key issue in process technology, since fluid flow in process apparatus is generally turbulent and predicting flow quantities is a central issue in their design. A theory has been developed for stochastic turbulence, which involves asymptotically exact solution methods and reveals the truncation errors. The theory has been validated by means of direct numerical simulation. Concerning numerical research, faster and more efficient numerical methods for DNS and LES models for particle-laden turbulent flow are being developed. Experimental research into inhomogeneous turbulence at intermediate and high Reynolds number is carried out by means of 3D-PTV in turbulent pipe flow.

2. PHASE-TRANSITIONAL FLOW

Fluid flow in which a phase change occurs is of considerable importance in process technology. The research is focused on boiling, (dropwise) condensation and sublimation. The research is generic, aiming at results that are applicable in numerical methods and for the design of unit operations. As examples, the dependencies of drag and lift force coefficients on acceleration of bubbles and particles have been studied and the effect of the velocity field caused by condensation directly downstream of the inlet of a confined steam jet on self-similarity has been investigated. Current research focuses on inertia-dominated interaction of flow and bubbles or particles and on basic mechanisms of condensation and sublimation. The approach followed is analytical, experimental and numerical. A multi-scale method, based on and validated by dedicated experiment and numerical simulation, is being developed.

3. ROTATING FLUID FLOW

The insights gained in the first two topics are applied to new concepts of process technology, mainly in the area of rotational equipment and separation devices. These projects are carried out in close cooperation with industry and comprise the design, manufacturing and testing of new equipment. Centrifugal phase separation offers excellent opportunities for innovation. A relatively new means of ship propulsion is based on water jets driven by pumps. The group studies the effects of non-uniform intake flow on performance and forces of the pump. A combination of experimental methods and numerical simulation is used for this purpose.

ASSESSMENT OF DISCRETIZATION METHODS FOR DNS OF TURBULENT CHANNEL FLOW

PROJECT AIM

The projects aims to investigate the accuracy of discretization methods for DNS of turbulent channel flow.

PROGRESS

It has been shown that the standard database for frictional Reynolds number 180 is not as accurate as always assumed. The accuracy of finite difference and spectral methods has been compared at various spatial resolutions. Later the work has been extended to higher Reynolds number and in particular the statistics of spatial derivatives of velocity and pressure has been determined.

DISSERTATIONS

-

SCIENTIFIC PUBLICATIONS

1. A. W. Vreman, J.G.M. Kuerten, Statistics of spatial derivatives of velocity and pressure in turbulent channel flow, Phys. Fluids, 26, 085103 (2014).
2. A. W. Vreman, J.G.M. Kuerten, Comparison of direct numerical simulation databases of turbulent channel flow at $Re\tau=180$, Phys. Fluids, 26, 015102 (2014).

PROJECTLEADERS

CWM van der Geld, JGM Kuerten

RESEARCHTHEME

Complex dynamics of fluids

PARTICIPANTS

JL Goes Oliveira, CWM van der Geld, JGM Kuerten

COOPERATIONS

-

FUNDED

| | |
|--------------|-------|
| TU/e | |
| University | 100 % |
| FOM | - |
| STW | - |
| NWO Other | - |
| Industry | - |
| TNO | - |
| GTI | - |
| EU | - |
| Scholarships | - |

START OF THE PROJECT

2003

INFORMATION

CWM van der Geld
040 247 2923
c.w.m.v.d.geld@tue.nl
www.wtb.tue.nl/woc/ptc

PROJECT LEADERS

CWM van der Geld, JGM Kuerten,
B Geurts

RESEARCH THEME

Complex dynamics of fluids

PARTICIPANTS

G Priems, P Cifani, W Michalek, C
van der Geld, J Kuerten, B Geurts

COOPERATIONS

UT, Stork, NEM, NRG

FUNDED

Stork Thermeq, NEM, NRG

| | |
|--------------|------|
| University | - |
| FOM | - |
| STW | 78 % |
| NWO Other | - |
| Industry | 22 % |
| TNO | - |
| GTI | - |
| EU | - |
| Scholarships | - |

START OF THE PROJECT

2013

INFORMATION

CWM van der Geld
040 247 2923
c.w.m.v.d.geld@tue.nl
www.tue.nl

PROJECT AIM

The intended main results of this project are twofold: (1) flow pattern maps for heated two-phase flows, of water-steam and of the model system HFE7000 and its vapor, and (2) a multi-scale numerical method to determine such flow pattern maps which is validated for the measurement conditions for which these maps have been established.

PROGRESS

Giel Priems started designing test rigs, studying scaling theory and selecting measurement instrumentation. P. Cifani started earlier and completed VOF simulations with Open Foam of a rising and deforming bubble. W. Michalek started part-time late 2014 and studied mass transfer across an interface with Fluent, as a follow-up of a research project for Shell involving 2 or more components and evaporation/condensation.

DISSERTATIONS

-

SCIENTIFIC PUBLICATIONS

-

BiOxyFUEL: TORREFIED BIOMASS COMBUSTION UNDER OXY-FUEL CONDITIONS IN COAL-FIRED POWER PLANTS

PROJECT AIM

In this project interaction between different kinds of particles and between particles and flow will be studied in which the properties of the particles, such as size, shape, temperature and chemical composition change in time because of combustion and flow of the surrounding gas. Particles will be treated as point particles, but detailed numerical simulations will be carried out to obtain correlations for the forces on a particle.

PROGRESS

A compressible DNS code has been developed with particles and two-way coupling in which the particles represent biomass particles and undergo pyrolysis. A combination of biomass and coal particles has been implemented and the effect of the presence of biomass particles on the pyrolysis of coal has been investigated. This project has been finished in 2014.

DISSERTATIONS

1. E. Russo, DNS of particle-ladene turbulent flow with heat and mass transfer, PhD Thesis, Eindhoven University of Technology, february 2014.

SCIENTIFIC PUBLICATIONS

1. E. Russo, J.G.M. Kuerten, B.J. Geurts, Delay of biomass pyrolysis by gas-particle interaction, *J. Anal. Appl. Pyrolysis*, 110, 88-99 (2014).
2. E. Russo, J.G.M. Kuerten, B.J. Geurts. C.W.M. van der Geld, Water droplet condensation and evaporation in turbulent channel flow, *J. Fluid Mech.*, 749, 666-700 (2014).

PROJECTLEADERS

JGM Kuerten

RESEARCHTHEME

Complex dynamics of fluids

PARTICIPANTS

E Russo, JGM Kuerten, CWM van der Geld

COOPERATIONS

JA van Oijen, Y Haseli (TU/e)

EM Gucho, G Brem, BJ Geurts (UT)

FUNDED

| | |
|--------------|-------|
| STW | |
| University | - |
| FOM | - |
| STW | 100 % |
| NWO Other | - |
| Industry | - |
| TNO | - |
| GTI | - |
| EU | - |
| Scholarships | - |

START OF THE PROJECT

2010

INFORMATION

JGM Kuerten

040 247 2362

j.g.m.kuerten@tue.nl

www.wtb.tue.nl/woc/ptc

EFFECTS OF CROSS-SECTION VARIATION AND BUBBLE-BUBBLE INTERACTION ON BUBBLE DETACHMENT IN CONVECTIVE FLOW

PROJECT LEADERS

CWM van der Geld, JGM Kuerten

RESEARCH THEME

Complex dynamics of fluids

PARTICIPANTS

C Baltis, J Desmarais, CWM van der Geld, JGM Kuerten

COOPERATIONS

DAF, Spirotech B.V.

FUNDED

STW

University -

FOM -

STW 100 %

NWO Other -

Industry -

TNO -

GTI -

EU -

Scholarships -

START OF THE PROJECT

2010

INFORMATION

CWM van der Geld

040 247 2923

c.w.m.v.d.geld@tue.nl

www.wtb.tue.nl/woc/ptc

PROJECT AIM

The effect of flow on boiling bubble detachment from a heated plane wall is investigated for the effects mentioned in the title. Experiments serve to validate a model based on the diffuse interface method that will be further developed.

PROGRESS

In 2014 the boundary conditions for the diffuse interface model have been further extended to 2D based on extensions of the characteristic method and the method of perfectly matched layers. Also solid-wall boundary conditions have been studied and implemented. Measurements have been performed and analyzed with a new test section with multiple bubble generators at artificial sites. The angle of inclination was varied in another test section which was designed, built and tested. Results of both experiments were reported on conferences and publications were prepared and partly accepted.

DISSERTATIONS

1. C.H.M. Baltis, Nucleate boiling bubble mechanics in forced convection, PhD Thesis, Eindhoven University of Technology, November 2014.

SCIENTIFIC PUBLICATIONS

1. J.L. Desmarais, J.G.M. Kuerten, Open boundary conditions for the diffuse interface model in 1-D, *J. Comp. Phys.*, 263, 393-418 (2014).
2. C.H.M. Baltis, C.W.M. van der Geld, Experimental investigation of the thermal interactions of nucleation sites in flow boiling, *Int. J. Heat Mass Transf.*, 78, 2008-2018 (2014).

PARTICLE-PARTICLE INTERACTION IN BIOMASS CO-FIRING POWER PLANTS

PROJECT AIM

The aim of this research is to develop a model for the calculation of the thickness of deposition that results after evaporation of a solvent from a droplet and of the distribution of (bio)molecules on/in the substrate.

PROGRESS

A computational method will be developed to simulate the combined combustion of biomass and coal in biomass co-fired power plants. Realistic operation conditions of power plants involve particle volume fractions (typically 3×10^{-4}) that require incorporation of two-way interaction between particles and surrounding gas in terms of mass, momentum and energy, and particle-particle interaction by radiative heat transfer. The model would enable optimization of the combustion time, ash quality and emissions of the power plant by varying the particle composition and size. Effects of increased biomass fraction on the process efficiency will be quantified.

DISSERTATIONS

-

SCIENTIFIC PUBLICATIONS

-

PROJECT LEADERS

JGM Kuerten

RESEARCH THEME

Complex dynamics of fluids

PARTICIPANTS

A Awasthi, JGM Kuerten

COOPERATIONS

BJ Geurts

FUNDED

| | |
|-----------------------|-------|
| FOM, Shell University | - |
| FOM | 100 % |
| STW | - |
| NWO Other | - |
| Industry | - |
| TNO | - |
| GTI | - |
| EU | - |
| Scholarships | - |

START OF THE PROJECT

2013

INFORMATION

A Awasthi

06 87362754

A.Awasthi@tue.nl

www.wtb.tue.nl/woc/ptc

PROJECT LEADERS

JGM Kuerten

RESEARCH THEME

Complex dynamics of fluids

PARTICIPANTS

C Diddens, CWM van der Geld,

HMA Wijshoff

COOPERATIONS

Océ

FUNDED

STW, Océ

University -

FOM -

STW 58,6 %

NWO Other -

Industry 41,4 %

TNO -

GTI -

EU -

Scholarships -

START OF THE PROJECT

2014

INFORMATION

JGM Kuerten

040 247 2362

j.g.m.kuerten@tue.nl

www.wtb.tue.nl/woc/ptc

PROJECT AIM

The aim of this research is to generalize an existing model for the evolution of a sessile ink droplet subject to evaporation and absorption into a porous substrate by three further aspects:

(1) the model will be extended to incorporate the presence and influence of surfactants;

(2) to investigate the impact of neighboring droplets, a generalization to three dimensions is proposed;

(3) the absorption into the porous substrate will be extended to comprise more general types of porous substrates.

PROGRESS

The existing model has been studied and improved by a factor of more than 400% in terms of the required calculation time. This was mainly achieved by developing an appropriate multigrid algorithm for the flow in the porous substrate. Furthermore, the model was generalized to incorporate binary mixtures, where the evaporation rate, the dynamic viscosity and the mutual diffusion coefficient depend on the local fluid composition. The interplay of these local fluid properties leads to the intriguing phenomena that a water-glycerol droplet can dry the faster, the more humid the surrounding air is.

DISSERTATIONS

-

SCIENTIFIC PUBLICATIONS

1. L.H. Mujawar, J.G.M. Kuerten, D.P. Siregar, A. van Amerongen, W. Norde, Influence of the relative humidity on the morphology of inkjet-printed spots of IgG on a non-porous substrate, RSC Advances, 4, 19380 (2014).



Prof.dr.ir. D Smeulders



Prof.dr.ir. AA van Steenhoven



Prof.dr. HA Zondag

Research in the field of Energy Technology at a Mechanical Engineering Department requires the combination of fundamental research and the study of engineering systems and devices. The fundamental research is in the field of Heat Transfer, and the engineering system focuses on small-scale Energy Systems with a strong emphasis on sustainability.

The approach is to combine advanced experimental, analytical and numerical techniques to investigate fundamental topics in heat transfer, and to design, construct and test real energy conversion systems. In this way, the research also contributes to the engineering and research training of the mechanical engineering students. The research is concentrated on three topics:

A. HEAT TRANSFER AND TRANSITIONAL FLOWS.

The research in this area is aimed at a better understanding of the fundamental characteristics of transitional flows in general. Flow cases that are studied are bypass transition along a flat plate (related to turbine blade cooling), laminar thermal transport in compact systems and boiling process control (for heat removal and thermal homogenisation in, for example, lithographic systems). Another research line concentrates on non-equilibrium phase transitions in gas-vapor mixtures.

B. MICRO-SCALE HEAT TRANSFER AND FLOW PHENOMENA

The aim of this research line is to achieve a better understanding of the heat and mass transfer processes at the small scales. The focus is on evaporative cooling of electronic components, on multi-scale analysis for compact heat storage materials and permeable geothermal reservoirs, and the dynamics of integrated fluid drivers in micro systems. On the smallest scales the physical processes are studied by coupling Molecular Dynamics analysis with a Direct Simulation Monte Carlo model.

C. HEAT TRANSFER ENGINEERING

The research activities in this area focus more on the system level rather than on the phenomenological level. Main research projects are fouling of heat exchangers used in waste- incinerators and biomass gasifiers, the design of a humidity harvesting device, and heat transfer models in the built environment. Another research line concentrates on biomass reactors for thermo-chemical applications.

More information about the research activities in these areas can be found on our website: www.energy.tue.nl

PIPELINE ATTRITION ACOUSTIC LOCATOR (PAAL)

PROJECT AIM

As a large percentage of corrosion failures in the oil and gas industry originate from localized defects in carbon and low-alloy steels due to their poor general and CO₂ corrosion performance, an increased understanding of localizing and sizing of defects in piping will help reduce the failure rate. Down-time to failure is prohibitively expensive. There is therefore an urgent need for the development of a quick, reliable method for the detection of internal pipe defects. The use of cylindrical guided waves propagating along the pipe wall is potentially an attractive solution to this problem since they propagate a long distance in contrast to traditional ultrasonic testing where the coverage is limited to the area in the vicinity of the sensor. This letter describes the development of such a guided wave testing technique for the inspection of downstream pipework, the original aim being to detect and locate wall thinning due to corrosion, cracks, and stress-induced strain.

PROGRESS

Guided wave testing has been applied for rapid screening of long lengths of pipework for corrosion and other defects. The method employs mechanical stress waves that propagate along an elongated structure while guided by object's boundaries. It uses permanently installed transducers on the pipe outer wall for continuous monitoring. The method enables tracking and trending signal change and allows amplitude analysis. Signal processing, such as bandpass filtering, Fourier decomposition, and dispersion imaging further improve the signal-to-noise-ratio. Stability and sensitivity experiments demonstrate the capabilities of the method to detect circumferential wall loss (fractional defect depth), high probability of axial damage localization at resonant frequency, and low probability of false indication. The figure shows that even slight wear on the inside wall can be detected at a distance of just a few meters from the transducers.

DISSERTATIONS

-

SCIENTIFIC PUBLICATIONS

1. Golombok, Michael and Bouko Vogelaar, 2014, A pipe fault detection system, US patent (filed).
2. Golombok, Mike, Bouko Vogelaar, and Xander Campman, 2014, A new pipeline monitoring method with help from geophysics. Shell TechXplorer, Vol 02, No 06, 10-14.
3. Vogelaar, Bouko, Michael Golombok, and Xander Campman, 2014, Acoustically locating pipeline defects, submitted to Ultrasonics.
4. Vogelaar, Bouko and Michael Golombok, 2014, Quantification and localization of internal pipe damage, submitted to Mechanical Systems and Signal Processing.

PROJECT LEADERS

DMJ Smeulders

RESEARCH THEME

Complex dynamics of fluids

PARTICIPANTS

B Vogelaar, M Golombok

COOPERATIONS

Shell Global Solutions

FUNDED

| | |
|--------------|-------|
| Industry | |
| University | - |
| FOM | - |
| STW | - |
| NWO Other | - |
| Industry | 100 % |
| TNO | - |
| GTI | - |
| EU | - |
| Scholarships | - |

START OF THE PROJECT

2012

INFORMATION

B Vogelaar
040 247 2135
B.B.S.A.Vogelaar@tue.nl
www.tue.nl

Reflection coefficient as a function of wear in a carbon steel pipe

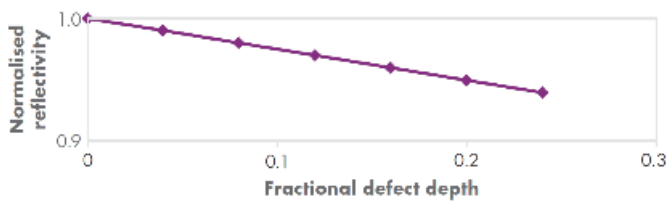

LAGRANGIAN “MIXING ANALYSIS” OF HEAT TRANSFER: A NEW WAY FOR THERMAL OPTIMISATION

PROJECT LEADERS

MFM Speetjens, HJH Clercx, DMJ Smeulders

RESEARCH THEME

Mathematical and computational methods for fluid flow analysis

PARTICIPANTS

EA Demissie

COOPERATIONS

Ö Baskan (PhD candidate of companion Project at dept. Applied Phys., Tu/e); G Metcalfe, CSIRO-MMT, Melbourne, Australia; F Posthuma-Scholtes, Primix BV, Mijdrecht; B Ohlmeier, DSM Research, Geleen; W Maas, Mecal NV, Veldhoven; A Reusken, Dept. Mathematics, RWTH, Aachen, Germany.

FUNDED

| | |
|--------------|-------|
| STW | - |
| University | - |
| FOM | - |
| STW | 100 % |
| NWO Other | - |
| Industry | - |
| TNO | - |
| GTI | - |
| EU | - |
| Scholarships | - |

START OF THE PROJECT

2011

INFORMATION

MFM Speetjens
040 247 5428
m.f.m.speetjens@tue.nl
www.energy.tue.nl

PROJECT AIM

Heat transfer admits representation in terms of the “motion of a fluid.” This fundamental change in thermal modeling enables thermal analysis in terms of the thermal trajectories (thermal counterpart to fluid trajectories) by well-established and very successful methods from mixing studies. This Lagrangian mixing analysis of heat transfer offers promising new thermofluids engineering capabilities beyond those of conventional Eulerian approaches based on e.g. temperature fields. Aim of the study is further development of this concept for practical utilization by way of representative industrial heat exchangers based on the static-mixing principle.

PROGRESS

The impact of three-dimensionality (3D) and fluid inertia on the dynamics and the Lagrangian transport properties for inline mixers with cylindrical geometries are investigated in terms of coherent structures that form in the 3D streamline portrait. Further progress has been made on development of a thermal-optimization procedure based on the Lagrangian heat-transfer formalism. The basic idea is to “design” the most optimal flow field required to reach a given thermal objective using only the temperature field that occurs in the absence of flow. This procedure currently adopts the Rotated Arc mixer (RAM) as a representative system and being tested and refined by way of 2D case studies..

DISSERTATIONS

-

SCIENTIFIC PUBLICATIONS

1. Speetjens, M.F.M., Demissie, E.A., Metcalfe, G. & Clercx, H.J.H. (2014). Lagrangian transport characteristics of a class of three-dimensional inline-mixing flows with fluid inertia. *Physics of Fluids*, 26(11), 113601.

(Left) Multiple families of streamtubes. (Right) Typical cross-sectional mixing pattern visualized by axial Poincaré sectioning at the inlet of 2D streamline pattern.

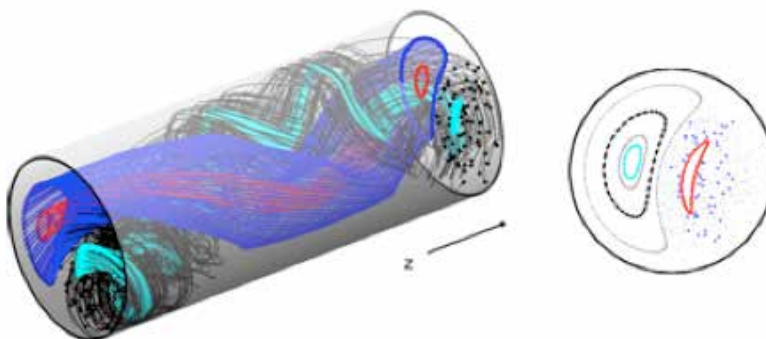

CRYSTALLIZATION, NUCLEATION AND DROPLET GROWTH FOR THE COMBINED GAS TREATMENT AND LIQUEFACTION OF NATURAL GAS

PROJECT AIM

Liquefaction of natural gas involves several pre-treatment steps to remove contaminants from raw natural gas, such as: water, carbon dioxide, ethane, butane, nitrogen. These components are being removed to prevent their deposition at cryogenic conditions on equipment during actual liquefaction process, meet the international LNG sales and purchase agreements. In this research project we evaluate the feasibility of liquefaction of natural gas, with very limited gas treatment or heavy carbons removal, by investigating phase transitions (crystallization points, nucleation rates and Wilson points) for multi-component gas mixtures. The goal is to acquire the adequate description of nucleation phenomena, build the corresponding computational model.

PROGRESS

On one hand molecular dynamics simulations were carried out for single-component systems (Argon, Helium) to gain a close-up look at homogeneous nucleation process. This was studied by tracing and analyzing parameters such as: temperature of the system, maximum cluster size and onset of nucleation. On the other hand experiments were performed in an Expansion Cloud Chamber set-up for detection of liquid and solid formation in carbon dioxide and natural gas mixture. The chamber was filled up with gas mixture at given pressure. By means of a rapid electromagnetic valve, the gas was expanded into the vacuum tank giving rise to condensation and crystallization phenomena.

DISSERTATIONS

-

SCIENTIFIC PUBLICATIONS

-

PROJECT LEADERS

DJM Smeulders, JAM Dam

RESEARCH THEME

Complex dynamics of fluids

PARTICIPANTS

LR Dumitrescu

COOPERATIONS

Shell, TU/e, TKI Gas

FUNDED

| | |
|----------------------|------|
| Shell, TU/e, TKI Gas | |
| University | 75 % |
| FOM | - |
| STW | - |
| NWO Other | - |
| Industry | 25 % |
| TNO | - |
| GTI | - |
| EU | - |
| Scholarships | - |

START OF THE PROJECT

2013

INFORMATION

DMJ Smeulders

040 247 3167

d.m.j.smeulders@tue.nl.

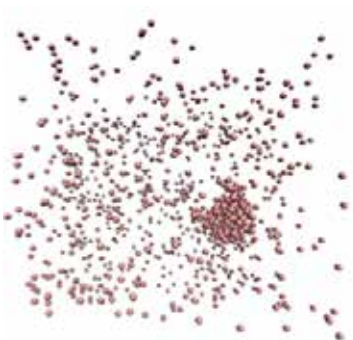

Snapshot of nucleation simulation in single-component Argon box system

PROJECT LEADERS

MFM Speetjens, RR Trieling, F Toschi

RESEARCH THEME

Complex dynamics of fluids

PARTICIPANTS

S Varghese

COOPERATIONS

Shell

FUNDED

Shell, FOM
 University -
 FOM 100 %
 STW -
 NWO Other -
 Industry -
 TNO -
 GTI -
 EU -
 Scholarships -

START OF THE PROJECT

2014

INFORMATION

MFM Speetjens
 040 247 5428
 m.f.m.speetjens@tue.nl
 www.tue.nl/staff/m.f.m.speetjens

PROJECT AIM

A major cause for sub-optimal performance of enhanced oil, gas and heat recovery from underground reservoirs is incomplete throughflow of the production fluid due to preferential flow via large fractures. Here we propose a radically different approach based on chaos theory which can boost performance by distributing production fluids throughout the entire reservoir. First aim is development of a hybrid computational model: (i) Fracture-scale modelling of a representative elementary volume by the lattice Boltzmann method (LBM) for determination of the Darcy transport coefficients (ii) Reservoir-scale modelling by a Darcy-type representation of the global flow in the fracture network. This is to be completed by post-processing modules for visualization and characterization of transport by methods from chaos theory. The computational suite is to be employed for reservoir simulations and chaos-inspired optimization of exploration schemes.

PROGRESS

Currently validating TU/e-WDY's LBM code for simulating fluid flow through porous media for extraction of Darcy's transport coefficients.

DISSERTATIONS

-

SCIENTIFIC PUBLICATIONS

-

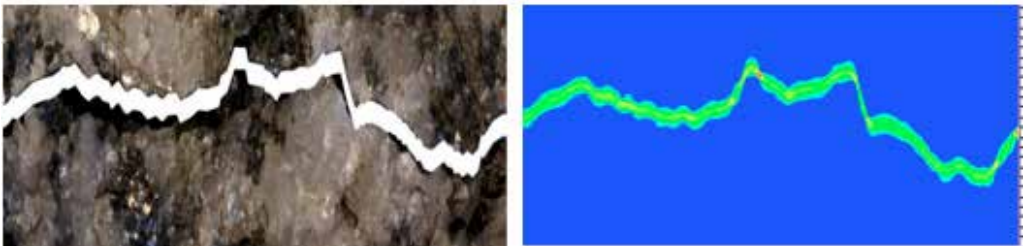

LBM simulation of fluid flow through a realistic fracture

COUPLED MASS AND HEAT TRANSFER IN POROUS MEDIA WITH AN APPLICATION TO THERMAL ENERGY STORAGE

PROJECT AIM

To fundamentally understand, optimize and develop solid sorption materials for thermal energy storage, a model will be developed taking all physical processes at the porous microscale into account. These processes include for example reaction between a multiphase fluid and the solid, diffusion, adsorption, changing solid matrices, and transport of mass, momentum and energy. Multiple methods to derive macroscopic measurable quantities from the microscopic equations governing the system are investigated. Different experimental and/or numerical techniques will be used to validate the model, and measure the response by determining macroscopic measurable quantities given certain boundary conditions applied on the system.

PROGRESS

-

DISSERTATIONS

-

SCIENTIFIC PUBLICATIONS

-

PROJECT LEADERS

DMJ Smeulders

RESEARCH THEME

Complex dynamics of fluids

PARTICIPANTS

SJA van der Linden, L Pel, CCM

Rindt

COOPERATIONS

-

FUNDED

ADEM Innovation Lab

University -

FOM -

STW -

NWO Other 100 %

Industry -

TNO -

GTI -

EU -

Scholarships -

START OF THE PROJECT

2014

INFORMATION

S van der Linden

040 247 2320

s.j.a.v.d.linden@tue.nl

www.energy.tue.nl

PROJECT LEADERS

AJH Frijns, AA van Steenhoven

RESEARCH THEME

Mathematical and computational methods for fluid flow analysis

PARTICIPANTS

G Gürsel

COOPERATIONS

Holst Centre, IMEC, Philips

FUNDED

| | |
|--------------|-------|
| STW | |
| University | - |
| FOM | - |
| STW | 100 % |
| NWO Other | - |
| Industry | - |
| TNO | - |
| GTI | - |
| EU | - |
| Scholarships | - |

START OF THE PROJECT

2001

INFORMATION

A Frijns
 040 247 4825
 a.j.h.frijns@tue.nl
 www.energy.tue.nl

PROJECT AIM

Electronic devices will in the future be made more and more also as flexible system-in-foil (SIF) which can contain ultra-thin (15-50 micron) flexible embedded silicon chips. A challenge is given by the low thermal conductivity of the very thin polymeric package aggravating the heat management problem. The aim of this project is to develop an integrated micro-fluidic cooling system in a laminated flexible micro-system.

PROGRESS

A 1D mass-spring-damper model is developed to investigate the motion in pulsating heat pipe (PHP). Also a heat transfer model is coupled with a mass-spring-damper model. Results of this study reveal that as the heat input increases, the performance of the PHP also increases. Also, the motion composition in the PHP is studied and it was seen that there are four types of motion (no motion, oscillatory motion, combined oscillatory and translational motion and translational motion). The results of these studies show that PHP has the best performance when it is running in combined or translational state.

DISSERTATIONS

-

SCIENTIFIC PUBLICATIONS

- Gürsel, G., Frijns, A.J.H., Homburg, F.G.A. & Steenhoven, A.A.van. (2014). A mass-spring-damper model of a pulsating heat pipe with asymmetric filling. Proceedings of the 5th Heat Transfer and Fluid Flow in Microscale, Marseille, France.
- Gürsel, G., Frijns, A.J.H., Homburg, F.G.A. & Steenhoven, A.A.van. (2014). Asymmetry and geometry effects on the dynamic behavior of a pulsating heat pipe. Proceedings of the 4th European Conference on Microfluidics, Limerick, Ireland.

Left: Thermal resistance as a function of time is shown. Box plots are the results of the model. Black line and blue line are the experimental and numerical results from literature for validation, respectively. Right: The motion composition as a function of time is shown.

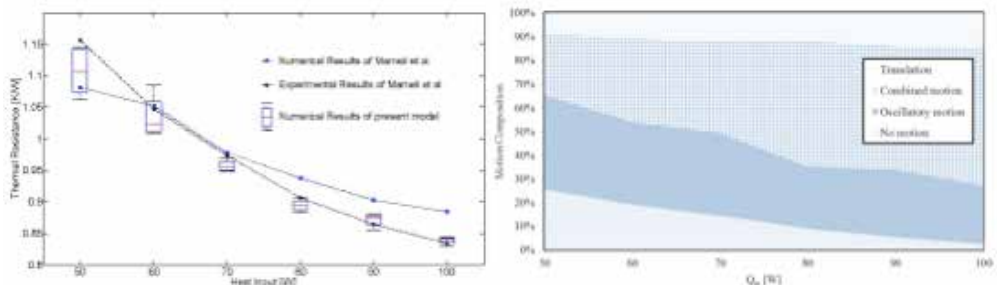

MICRO-OPTO-FLUIDIC SENSING

PROJECT AIM

The occurrence of acute and chronic cardiovascular complications in dialysis patients is high. Insufficient correction of uremic state by conventional dialysis plays an important underlying role. Conventional hemodialysis uses a 'one size fits all' approach with a fixed dialysate concentration of electrolytes. Individualization of dialysate prescription is hampered because no suitable on-line ion-selective electrolyte monitoring is available. This project aims to develop and compare novel optical sensor technologies for continuous ion-selective monitoring of electrolytes in dialysate.

PROGRESS

Optical sensors offer intrinsic electrical safety (no galvanic contact), good miniaturization perspective, improved biocompatibility (contactless sensing), less fouling and simultaneous measurement of multiple ions. We investigate two novel optical sensor technologies based on: Photo-induced electron transfer (PET) and laser induced breakdown spectroscopy (LIBS). We built first lab set-ups for testing both optical sensor techniques. Our results show that both optical sensor principles indeed work. Further research on optimization and miniaturization is ongoing.

DISSERTATIONS

-

SCIENTIFIC PUBLICATIONS

1. Sharma, M.K., Frijns, A.J.H., Mandampambal, R., Kooman, J.P. & Smeulders, D.M.J. (2014). Development of a micro opto-fluidic sensor for continuous selective in-line monitoring of electrolytes. In S Colin, GL Morini, JJ Brandner & D Newport (Eds.), Conference Paper : Proceedings of the 4th European Conference on Microfluidics, 10-12 December 2014, Limerick, Ireland, (pp. muFLU14-56). SHF.

PROJECT LEADERS

AJH Frijns

RESEARCH THEME

Complex structures of fluids

PARTICIPANTS

M Sharma, DMJ Smeulders, FP Wieringa, R Mandampambal, JP Kooman

COOPERATIONS

TNO, MUMC+

FUNDED

| | |
|-------------------|-------|
| Kidney Foundation | |
| University | - |
| FOM | - |
| STW | - |
| NWO Other | - |
| Industry | 100 % |
| TNO | - |
| GTI | - |
| EU | - |
| Scholarships | - |

START OF THE PROJECT

2013

INFORMATION

AJH Frijns
040 247 4825
a.j.h.frijns@tue.nl
www.energy.tue.nl



PROJECT LEADERS

AJH Frijns, AA van Steenhoven

RESEARCH THEME

Mathematical and computational methods for fluid flow analysis

PARTICIPANTS

SV Nedea, JH Kim

COOPERATIONS

GASMEMS

FUNDED

FP7

University -

FOM -

STW -

NWO Other -

Industry -

TNO -

GTI -

EU 100 %

Scholarships -

START OF THE PROJECT

2005

INFORMATION

A Frijns

040 247 4825

a.j.h.frijns@tue.nl

www.energy.tue.nl

PROJECT AIM

For microchannel gas flows, macroscopic models for heat transfer are not sufficient to describe the cooling mechanisms. Therefore particle-based models have to be used. The goal of this project is to study the convective heat transfer and evaporative cooling in micro-devices by Molecular Dynamics (MD) and Direct Simulation Monte Carlo (DSMC) techniques and to develop a multi-scale simulation method.

PROGRESS

Molecular dynamics simulations of heat transfer in gases are computationally expensive when the wall molecules are explicitly modeled. To save computational time, an implicit boundary function is often used. In this work, the conceptual idea of Steele's potential was extended in order to simulate water-silicon and water-silica interfaces. A new wall potential model is developed by using the electronegativity-equalization method (EEM), a ReaxFF empirical force field and a non-reactive molecular dynamics package PumMa. Contact angle simulations were performed in order to validate the wall potential model. The MD results are in agreement with experimental values. Finally the model is applied to an outgassing problem.

DISSERTATIONS

1. Kim, J. (2014). Molecular models for water vapor flows in silica nanopores. Eindhoven: Technische Universiteit Eindhoven. ((Co-)promot.: prof.dr.ir. A.A. van Steenhoven, dr.ir. A.J.H. Frijns & dr. S.V. Gaastra - Nedea).

SCIENTIFIC PUBLICATIONS

1. Kim, J., Iype, E., Frijns, A.J.H., Gaastra - Nedea, S.V. & Steenhoven, A.A. van (2014). Development of EEM based silicon-water and silica-water wall potentials for non-reactive molecular dynamics simulations. *Journal of Computational Physics*, 268, 51-62.
2. Kim, J., Frijns, A.J.H., Gaastra - Nedea, S.V. & Steenhoven, A.A. van (2014). Molecular simulation of water vapor outgassing from silica nanopores. In S Colin, GL Morini, JJ Brandner & D Newport (Eds.), *Conference Paper : Proceedings of the 4th European Conference on Microfluidics*, 10-12 December 2014, Limerick, Ireland, (pp. muFLU14-69). SHF.

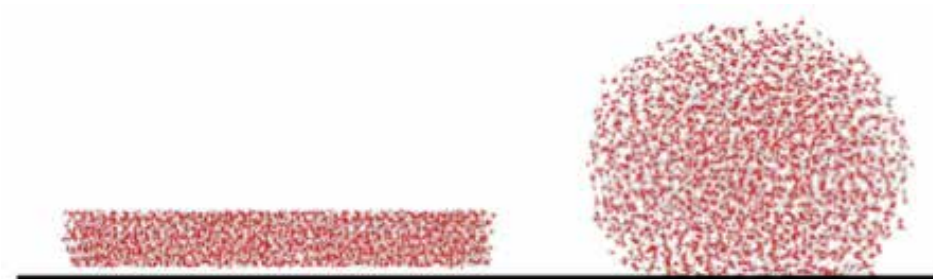

Initial and an equilibrated configuration of water molecules on top of a silicon wall

INTEGRATED MICRO-FLUIDIC COOLING IN LAMINATED FLEXIBLE MICRO-SYSTEMS

PROJECT AIM

Electronic devices will in the future be made more and more also as flexible system-in-foil (SIF) which can contain ultra-thin (15 – 50 micron) flexible embedded silicon chips. A challenge is given by the low thermal conductivity of the very thin polymeric package aggravating the heat management problem. The aim of this project to develop an integrated micro-fluidic cooling system in a laminated flexible micro-system.

PROGRESS

A new modelling approach was followed: the system is modelled by a non-linear mass-spring-damper system and was implemented in SIMULINK. Main advantages of such approach that the results are easier to interpret than in a CFD model, since it can be related to the non-linear springs and dampers. Therefore, the effects of asymmetry in filling and in material properties and the stability issues can be better addressed. Evaporation and condensation are included in de model. The model is compared with both numerical and experimental results from literature. Simulations show that including asymmetry into the system results in a good agreement with experimental results. Also, four different modes of motion are observed: Oscillatory motion, translation, combined oscillatory-translation motion and no motion. Motion composition of a PHP as a function of heat input is analyzed.

DISSERTATIONS

-

SCIENTIFIC PUBLICATIONS

1. Gursel, G., Frijns, A.J.H., Homburg, F.G.A. & Steenhoven, A.A. van (2014). A mass-spring-damper model of a pulsating heat pipe with asymmetric filling. In L. Tadrist & I. Graur (Eds.), Conference Paper : Proceedings of the 5th International Conference on Heat Transfer and Fluid Flow in Microscale (HTFFM-V), 22-25 April 2014, Marseille, France, ECI.
2. Gursel, G., Frijns, A.J.H., Homburg, F.G.A. & Steenhoven, A.A. van (2014). Asymmetry and geometry effects on the dynamic behavior of a pulsating heat pipe. In S Colin, GL Morini, JJ Brandner & D Newport (Eds.), Conference Paper : Proceedings of the 4th European Conference on Microfluidics, 10-12 December 2014, Limerick, Ireland, (pp. muFLU14-66). SHF.

PROJECTLEADERS

AJH Frijns, AA van Steenhoven

RESEARCHTHEME

Complex dynamics of fluids

PARTICIPANTS

G Gürsel, D Florea, E Homburg, JMJ den Toonder

COOPERATIONS

Phillips, Holst Centre

FUNDED

| | |
|--------------|-------|
| STW | |
| University | - |
| FOM | - |
| STW | 100 % |
| NWO Other | - |
| Industry | - |
| TNO | - |
| GTI | - |
| EU | - |
| Scholarships | - |

START OF THE PROJECT

2011

INFORMATION

AJH Frijns
040 247 4825
a.j.h.frijns@tue.nl
www.energy.tue.nl

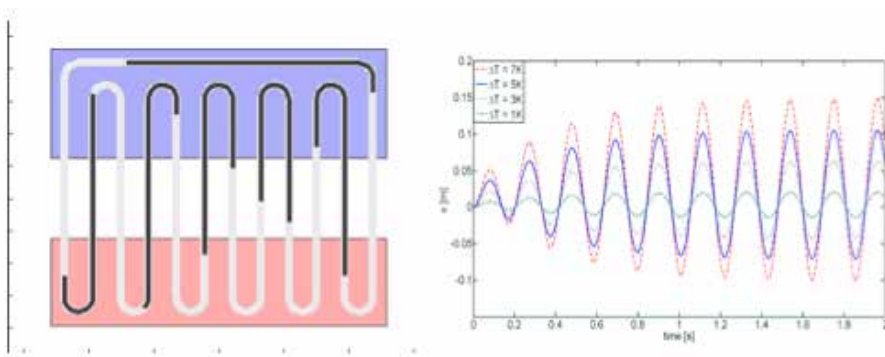

Pulsating heat pipe (left) and oscillatory motion of a plug (right).

MOLECULAR MODELING OF SUGAR ALCOHOLS AS SEASONAL HEAT STORAGE MATERIALS

PROJECT LEADERS

DMJ Smeulders, SV Nedeaa, CCM Rindt

RESEARCH THEME

Mathematical and computational methods for fluid flow analysis

PARTICIPANTS

H Zhang

COOPERATIONS

CNRS-I2M

FUNDED

EU-FP7

University -

FOM -

STW -

NWO Other -

Industry -

TNO -

GTI -

EU 100 %

Scholarships -

START OF THE PROJECT

2012

INFORMATION

H Zhang (e.g. EPM Abzach)

040 247 3172

h.zhang@tue.nl

The three most promising SAs as seasonal heat storage material and a simulation of xylitol solid liquid interface

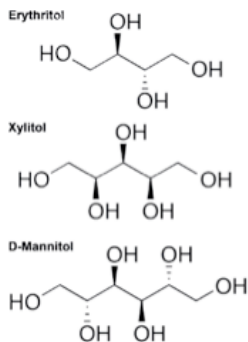

PROJECT AIM

Sugar alcohols (SA) and their eutectic mixtures are promising seasonal heat storage medium. These materials are environmentally friendly, low cost, and high in storage capacity. In the summer, SA is heated and melted to store the heat. Because of the large subcooling effect, SA can remain in liquid state at very low temperature without solidification. In the winter, the latent heat is discharged by triggering nucleation via mechanical shock. Nevertheless, the low nucleation rate and unpredictable growth pattern hinder the heat transfer process, resulting in poorly controlled discharge power and introduces difficulties in large scale industrial applications. Using molecular modeling methods, we can tackle the details during the nucleation process, depict the free energy landscape, and propose possible solutions to increase the nucleation and crystal growth kinetics.

PROGRESS

The interfacial free energy of SA is studied. The large anisotropic free energy values may account the dramatic dendritic growth behaviors observed in the experiments. The vibrational density of state throughout the melting process is calculated using molecular dynamics simulations. At the point where phase transition happens, many thermodynamic properties change instantly.

DISSERTATIONS

-

SCIENTIFIC PUBLICATIONS

1. Zhang, H., Iype, E., Gaastra - Nedeaa, S.V. & Rindt, C.C.M. (2014). Molecular dynamics study on thermal dehydration process of epsomite ($\text{MgSO}_4 \cdot 7\text{H}_2\text{O}$). *Molecular Simulation*, 40(14), 1157-1166.
2. Zhang, H., Wissen, R.M.J. van, Gaastra - Nedeaa, S.V. & Rindt, C.C.M. (2014). Characterization of sugar alcohols as seasonal heat storage media - experimental and theoretical investigations. Conference Paper : Proceedings of the Advances in Thermal Energy Storage, EURO THERM 99, 28-30 May 2014, Lleida, Spain, (pp. EURO THERM99-01-020). Lleida, Spain.
3. Zhang, H., Gaastra - Nedeaa, S.V., Rindt, C.C.M., Zondag, H.A. & Smeulders, D.M.J. (2014). Prediction of anisotropic crystal-melt interfacial free energy of sugar alcohols through molecular simulations. Conference Paper : Proceedings of the 15th International Heat Transfer Conference (IHTC-15), August 10-15, 2014, Kyoto, Japan, (pp. IHTC15-8636). Begell House.

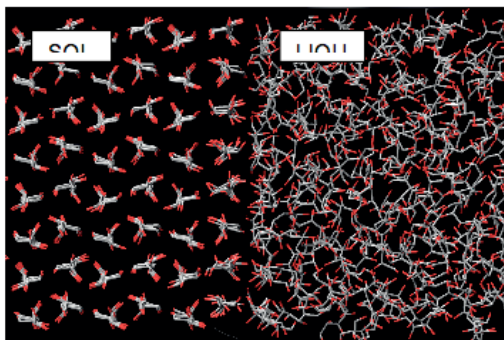

NUMERICAL MODELLING OF HYDRAULIC FRACTURING

PROJECT AIM

The aim of this project is to develop a numerical model to predict the propagating fracture patterns that grow during hydraulic fracturing. Such a numerical model may be useful to identify key parameters in the hydraulic fracturing process and may be helpful to optimize the fracture process.

PROGRESS

We developed the Enhanced Local Pressure (ELP) model in order to accurately predict the pressure gradient due to fluid leakage near a propagating hydraulic fracture surface. In this model, which can be considered as an extension of the partition of unity based representations, the pressure in the fracture is described by an additional set of degrees of freedom. The pressure gradient is reconstructed analytically, based on Terzaghi's consolidation solution. With this numerical formulation we also ensure that all externally applied fluid flow goes exclusively in the fracture and avoid the necessity to use a fine mesh near the fracture to capture the pressure gradient.

DISSERTATIONS

-

SCIENTIFIC PUBLICATIONS

1. Remij, E.W., Remmers, J.J.C., Pizzocolo, F., Smeulders, D.M.J. & Huyghe, J.M.R.J. (2014). A partition of unity-based model for crack nucleation and propagation in porous media, including orthotropic materials. *Transport in Porous Media*, 1-18.
2. Remij, E.W., Remmers, J.J.C., Huyghe, J.M.R.J. & Smeulders, D.M.J. (2014). Numerical modelling of hydraulic fracturing. In F. Oka, A. Murakami, R. Uzuoka & S. Kimoto (Eds.), *Conference Paper : Proceedings of the 14th international conference of international association for computer methods and recent advances in geomechanics*, Kyoto, Japan, 22-25 September 2014, CRC Press.

PROJECT LEADERS

JJC Remmers, JM Huyghe, DMJ Smeulders

RESEARCH THEME

Mathematical and computational methods for fluid flow analysis

PARTICIPANTS

EW Remij

COOPERATIONS

Baker Hughes, EBN, GDF Suez, TKI Gas, Total, Tu Delft, University Utrecht, Wintershall

FUNDED

Baker Hughes, EBN, GDF Suez, TKI Gas, Total, Wintershall

| | |
|--------------|-------|
| University | - |
| FOM | - |
| STW | - |
| NWO Other | - |
| Industry | 100 % |
| TNO | - |
| GTI | - |
| EU | - |
| Scholarships | - |

START OF THE PROJECT

2013

INFORMATION

E Remij
040 247 3124
e.w.remij@tue.nl
www.2f2s.org

Hydraulic fracture growing in the direction of the highest confining stress

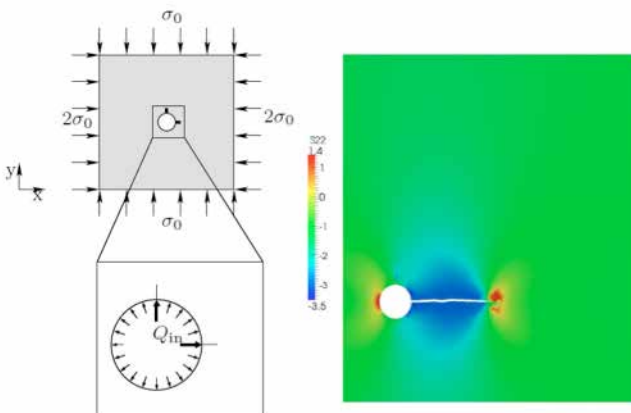

MODELING OF HEAT STORAGE MATERIALS

PROJECT LEADERS

CCM Rindt

RESEARCH THEME

Mathematical and computational methods for fluid flow analysis

PARTICIPANTS

HA Zondag, AA van Steenhoven

COOPERATIONS

ECN (Energy research Center of the Netherlands)

FUNDED

ADEM Innovation Lab Program

University -

FOM -

STW -

NWO Other 100 %

Industry -

TNO -

GTI -

EU -

Scholarships -

START OF THE PROJECT

2011

INFORMATION

CCM Rindt

040 247 2978

C.C.M.Rindt@tue.nl

www.energy.tue.nl

PROJECT AIM

For the purpose of the development of solid sorption materials, micro- and meso-scale models will be developed for the hydration and dehydration processes taking place in powdery samples. These processes are a combination of heat and vapor transport in the grains constituting the powdery sample and in the voids between the grains of the powdery sample. A complication in the modeling is that the solid-state kinetics in the hydration and dehydration processes is hard to be described satisfactorily. Besides, the macro- and micro- mechanical and transport properties will change during the reaction. Detailed characterization of interested materials has to be performed.

PROGRESS

A sharp interface model is developed to study the influence of water vapor diffusion in the reaction kinetics, as shown in Figure (left). $\text{Li}_2\text{SO}_4 \cdot \text{H}_2\text{O}$ monocrystals as a model material is investigated both numerically and experimentally. In experiments, a direct study of the reaction kinetics based on microscopic observations is done. The surface nucleation rate and surface growth rate at various temperatures and pressures are estimated and will be used in the previous nucleation and growth model. Moreover, experiments on encapsulated crystals are designed in order to measure the growth rate in-depth. The reaction-diffusion dynamics of the dehydration reaction of $\text{Li}_2\text{SO}_4 \cdot \text{H}_2\text{O}$ monocrystals is studied with the help of our sharp interface model (see Figure (right)). All information gathered so far will contribute to the more rigorous kinetic model, which bases on detailed phenomena during the reaction including nucleation and nuclei growth.

DISSERTATIONS

SCIENTIFIC PUBLICATIONS

1. Lan, S., Maris, M.P.F.H.L. van, Zondag, H.A. & Rindt, C.C.M. (2014). In situ observation of the dehydration of $\text{Li}_2\text{SO}_4 \cdot \text{H}_2\text{O}$ monocrystals. Conference Paper : Proceedings of Advances in Thermal Energy Storage, 28-30 May 2014, Lleida, Spain.
2. Lan, S., Zondag, H.A. & Rindt, C.C.M. (2014). Kinetic study of $\text{Li}_2\text{SO}_4 \cdot \text{H}_2\text{O}$ dehydration using microscopy and modeling. Conference Paper : Proceedings of the 15th International Heat Transfer Conference (IHTC-15), August 10-15, 2014, Kyoto, Japan, (pp. IHTC15-9000-1/10). Begell House.

Left: phase transformation of the hydrous phase (transparent) and the anhydrous phase (opaque) separated by a sharp interface. The salt crystal is encapsulated by a transparent polymer material except the right surface; Right: Profiles of water concentration distribution in a plane sheet. Dehydration starts at the surface and the time difference between two profiles in the figure is same

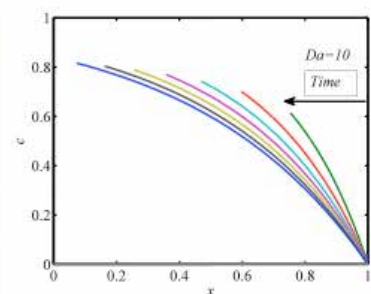

MULTISCALE SIMULATIONS FOR THERMO CHEMICAL HEAT STORAGE USING NEW COMPOSITE MATERIALS

PROJECT AIM

The promising concept for seasonal solar heat storage in the built environment is based on the reversible sorption process of water vapor into the crystalline structure of salt hydrates (MgSO₄, MgCl₂, LiSO₄, etc). Their main advantages are a high energy density, a reaction temperature in the proper range for domestic applications and their low price. However, the rate of heat release of these materials is low due to the low rate of hydration under atmospheric conditions. A detailed study on molecular level of the involved processes is necessary in order to gain insight into the dynamics of the hydration/dehydration processes and their limiting factors in these systems. We understood the effect of solid crystal into the dehydration reaction.

PROGRESS

The cost of TCM material is 30 % of the total investment in the thermochemical heat storage system. One of the key aspects in designing the solar based heat storage system is selection of TCM materials.

The major challenge in selection of these salt hydrates is their storage capacity and kinetics. MgCl₂.6H₂O is one of the most promising materials for thermal heat storage. It has very high energy storage density (2-3 GJ/m³) and is readily available.

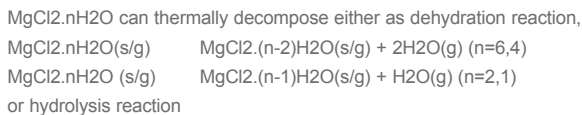

The dissociation of MgCl₂.2H₂O can lead to the hydrolysis reaction which generate a highly corrosive and harmful gas HCl gas and affects the durability of the storage system. Preference of the hydrolysis over the dehydration reaction is ambiguous from experiments. In present study we would like to understand the molecular perspective of preferential hydrolysis reaction over dehydration reaction. We will perform Density functional theory (DFT) and Density functional perturbation theory (DFPT) calculation to calculate Gibbs free energy of gas molecules and crystal respectively.

DISSERTATIONS

-

SCIENTIFIC PUBLICATIONS

-

PROJECT LEADERS

SV Gaastra-Nedea, HA Zondag,
CCM Rindt, DMJ Smeulders

RESEARCH THEME

Mathematical and computational methods for fluid flow analysis

PARTICIPANTS

A Deep Pathak

COOPERATIONS

ECN, FOM

FUNDED

| | |
|--------------|-------|
| FOM | |
| University | - |
| FOM | 100 % |
| STW | - |
| NWO Other | - |
| Industry | - |
| TNO | - |
| GTI | - |
| EU | - |
| Scholarships | - |

START OF THE PROJECT

2014

INFORMATION

A Deep Pathak
040 247 3172
a.d.pathak@tue.nl

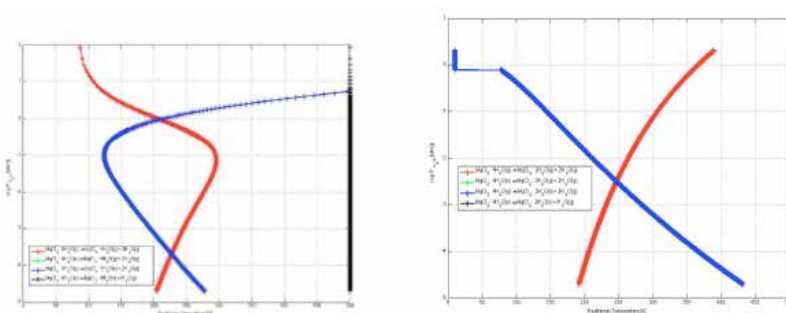

Effect of solid crystal/gas consideration on water pressure Vs Temperature plot of MgCl₂.XH₂O

THERMOCHEMICAL SEASONAL HEAT STORAGE FOR BUILT ENVIRONMENT

PROJECT LEADERS

HA Zondag, CCM Rindt

RESEARCH THEME

Mathematical and computational methods for fluid flow analysis

PARTICIPANTS

M Gaeini

COOPERATIONS

ECN

FUNDED

University, Province Noord Brabant

University 30 %

FOM -

STW -

NWO Other -

Industry -

TNO -

GTI -

EU 70 %

Scholarships -

START OF THE PROJECT

2013

INFORMATION

M Gaeini

040 247 2768

M.Gaeini@tue.nl

PROJECT AIM

Heat is stored by an endothermic reaction in thermo-chemical material (dehydration of salt) in summer and in winter released energy from exothermic reaction (hydration of salt) is used to provide hot tap water and space heating.

$$\text{salt} \cdot x\text{H}_2\text{O}(\text{s}) + \text{Q} \rightarrow \text{salt}(\text{s}) + x\text{H}_2\text{O}(\text{g})$$

The goal of the project is to develop and optimize a prototype thermo-chemical heat storage system in scale of 0.25 m³. The problem can be described on three levels; first, various materials should be examined to find the most suitable one for seasonal heat storage; second, the reactor as the main part of the setup should be technically optimized; third, all the other parts of the system, such as humidifier and heat exchangers, should be designed and integrated all together as a system.

PROGRESS

A Material investigation is started to evaluate the performance of the composite materials, such as impregnated salt hydrates in porous matrix materials. A 1D reactor model is developed, considering the heat and vapor transport processes and the chemical reaction, and is validated by experiments done in the reactor setup. The model is developing to a 2D model and it will be used in upscaling of the reactor. The so-called system setup, which is built as a proof of principle for the ability of the system in providing hot tap water, is tested and optimized. Improvement in the performance of the system caused by implementation of the heat recovery can be investigated by using a heater simulating the air-to-air heat exchanger. A parameter study is done by the system model which is developed for all parts of the system.

DISSERTATIONS

-

SCIENTIFIC PUBLICATIONS

1. Gaeini, M., de Jong, E.C.J., Zondag, H.A. & Rindt, C.C.M. Design of a thermochemical heat storage system for tap water heating in the built environment. Proceedings of the Advances in Thermal Energy Storage, EURO THERM 99, 28-30 May 2014, Lleida, Spain, (EUROTHERM99-02-015).
2. Gaeini, M., Zondag, H.A. & Rindt, C.C.M. Non-isothermal Kinetics of Zeolite Water Vapor Adsorption into a Packed Bed Lab Scale Thermochemical Reactor. Proceedings of the 15th International Heat Transfer Conference, IHTC-15, August 10-15, 2014, Kyoto, Japan, (IHTC15-9169).

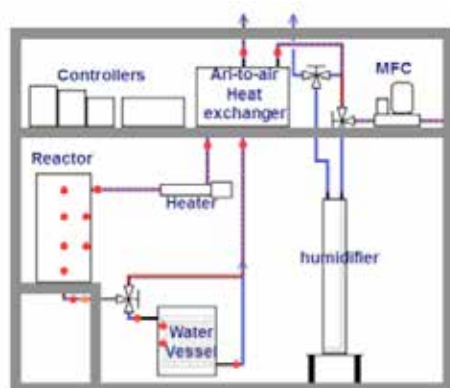

Schematic view of the system setup

PROJECT AIM

The goal of this project is to develop dynamic and human specific thermo-physiological model to predict the heat transfer and temperature distribution in the human body. The model will be used for the prediction of thermal comfort in the built environment.

PROGRESS

Our thermo-physiological model ThermoSEM is further improved by the introduction of a neurological based thermoregulation model. The new model outcomes are compared with experiments on volunteers. Good agreement is shown for blood flow, and for skin and core temperatures for young adults as well as for elderly. This thermo-physiological model was also used to predict the thermal responses to (changes in) the indoor climate. It was extended such that the thermal sensation can be predicted as well. Simulations and measurements showed a good agreement.

DISSERTATIONS

-

SCIENTIFIC PUBLICATIONS

1. Kingma, B.R.M., Vosselman, M.J., Frijns, A.J.H., Steenhoven, A.A. van & Marken Lichtenbelt, W. van (2014). Incorporating neurophysiological concepts in mathematical thermoregulation models. *International Journal of Biometeorology*, 58(1), 87-99.
2. Kingma, B.R.M., Frijns, A.J.H., Schellen, L. & Marken Lichtenbelt, W. van (2014). Beyond the classic thermoneutral zone : including thermal comfort. *Temperature*, 1(2), 10-17.

PROJECT LEADERS

AJH Frijns

RESEARCH THEME

Mathematical and computational methods for fluid flow analysis

PARTICIPANTS

S Veselá, BRM Kingma, H Pallubinsky, M te Culve, L Schellen, L Schlangen, WD van Marken Lichtenbelt, AA van Steenhoven, DMJ Smeulders

COOPERATIONS

MUMC+, Philips

FUNDED

| | |
|----------------|------|
| RVO, STW, TU/e | |
| University | 80 % |
| FOM | - |
| STW | - |
| NWO Other | 20 % |
| Industry | - |
| TNO | - |
| GTI | - |
| EU | - |
| Scholarships | - |

START OF THE PROJECT

2014

INFORMATION

A Frijns
040 247 4825
a.j.h.frijns@tue.nl
www.energy.tue.nl

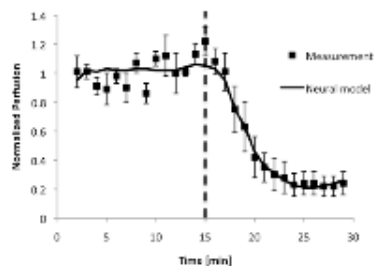
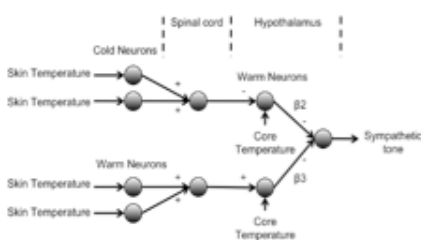

Neuro-physiological thermoregulation model(left) and measured and computed thermal sensation (right).

EXPERIMENTS ON VORTEX STRUCTURES IN AC ELECTRO-OSMOTIC FLOW

PROJECT LEADERS

AA van Steenhoven, AJH Frijns, MFM Speetjens

RESEARCH THEME

Mathematical and computational methods for fluid flow analysis

PARTICIPANTS

Z. Liu

COOPERATIONS

-

FUNDED

TU/e

University 100 %

FOM -

STW -

NWO Other -

Industry -

TNO -

GTI -

EU -

Scholarships -

START OF THE PROJECT

-

INFORMATION

AJH Frijns

040 247 4825

a.j.h.frijns@tue.nl

www.energy.tue.nl

PROJECT AIM

This project aims at a further 3D experimental investigation of vortex structures in AC electro-osmotic (ACEO) flow as function of operational parameters, i.e. voltage, frequency, electrolyte and additional axial flows. In addition, the possibility of particle focusing in ACEO will be investigated as well.

PROGRESS

This project aims at a further 3D experimental investigation of vortex structures in AC electro-osmotic (ACEO) flow as function of operational parameters, i.e. voltage, frequency, electrolyte and additional axial flows. In addition, the possibility of particle focusing in ACEO will be investigated as well.

DISSERTATIONS

- Liu, Z. (2014). Experiments on vortex structures in AC electro-osmotic flow. Eindhoven: Technische Universiteit Eindhoven. (Co-)promotors: prof.dr.ir. A.A. van Steenhoven, dr.ir. A.J.H. Frijns & dr.ir. M.F.M. Speetjens.

SCIENTIFIC PUBLICATIONS

- Liu, Z., Speetjens, M.F.M., Frijns, A.J.H. & Steenhoven, A.A. van (2014). Validated numerical analysis of vortical structures in 3D AC electro-osmotic flows. *Microfluidics and Nanofluidics*, 16(6), 1019-1032.
- Liu, Z., Frijns, A.J.H., Speetjens, M.F.M. & Steenhoven, A.A. van (2014). Particle focusing by AC electro-osmosis with additional axial flow. *Microfluidics and Nanofluidics*, online first.

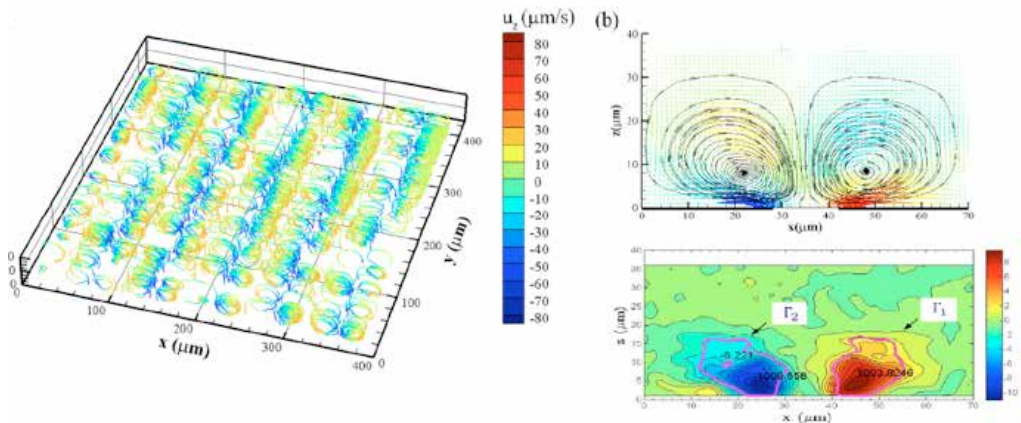

MICROSYSTEMS



Prof.dr.ir. JMJ den Toonder

The Microsystems group develops microsystems design approaches and out-of-cleanroom micro-manufacturing technologies that are rapid and flexible. these are applied to realize active mechanical control in micro-fluidics, to make and study meso-structured and soft materials, to create and study cells and organs on chips, and to develop advanced microsystems applications in collaboration with industrial partners. the group has a new micro-fabrication lab in development, and access to the Nanolab@TU/e cleanroom.

The Microsystems group is part of

MaTe, the Materials Technology Institute
ICMS, the Institute for Complex Molecular Systems
J.M.Burgerscentrum
EM, Graduate School on Engineering Mechanics
Human Organ and Disease Model Technologies

CANCER METASTASIS ON A CHIP

PROJECT AIM

The general goal of the project is to engineer tumor micro-environment in a controlled microfluidic system. In this work, our aim is to study the effect of extracellular matrix (ECM) stiffness on the invasive properties of the tumor cells. In order to realize a proper model for tumor, we are going to recreate the tumor micro-environment (including cancer cells, ECM and other cell types) inside a microfluidic chip. Then the invasion of the cancer cells into the blood stream will be investigated.

PROGRESS

We have successfully fabricated a microfluidic chip which replicates the Transwell migration assay. The fabrication method and the chip design were modified, comparing to the one reported in the literature, towards a smaller chip and easier fabrication method. We have seeded a monolayer of two invasive breast cancer cell lines (MDA-MB-231 and MCF-7) in our chip and compared the cell proliferation with conventional culture dishes. Also chemotaxis assays were conducted to study the motility of the cancer cells in response to chemical gradient.

DISSERTATIONS

-

SCIENTIFIC PUBLICATIONS

-

PROJECT LEADERS

JMJ den Toonder, R Luttge

RESEARCH THEME

Complex structures of fluids

PARTICIPANTS

H Eslami Amirabadi

COOPERATIONS

-

FUNDED

STW

University -

FOM -

STW 100 %

NWO Other -

Industry -

TNO -

GTI -

EU -

Scholarships -

START OF THE PROJECT

2013

INFORMATION

H Eslami Amirabadi,

06 48536093

h.eslami.amirabadi@tue.nl

www.tue.nl/en/university/departments/mechanical-engineering/the-department/staff/detail/ep/e/d/ep-uid/20118704/

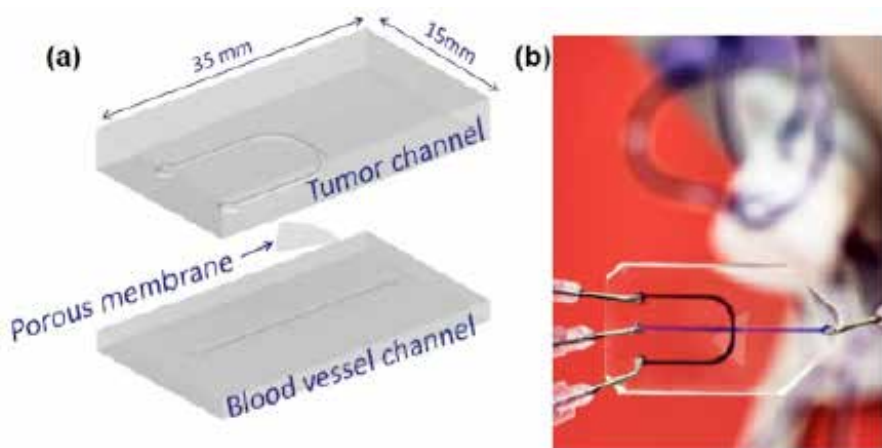

NEURONAL TISSUE ENGINEERING FOR BRAIN-ON-A-CHIP TECHNOLOGY

PROJECT LEADERS

JMJ den Toonder, R Luttge

RESEARCH THEME

Complex structures of fluids

PARTICIPANTS

A Bastiaens

COOPERATIONS

UT

FUNDED

TU/e

University 100 %

FOM -

STW -

NWO Other -

Industry -

TNO -

GTI -

EU -

Scholarships -

START OF THE PROJECT

2014

INFORMATION

A Bastiaens

040 247 4905

A.J.Bastiaens@tue.nl

www.tue.nl/universiteit/faculteiten/

faculteit-werktuigbouwkunde/

onderzoek/research-groups/

microsystems/

PROJECT AIM

The project aims to create an in-vitro microbio reactor for 3D neuronal tissue, mimicking the function of the human brain, that can be used to study neuronal connectivity and the associated (electrical and biological) functionality, and that can eventually be developed into a model for studying brain diseases such as epilepsy.

PROGRESS

To reach the aim, it is essential to create a microbio reactor in which the microenvironment of the neuronal tissue can be controlled, with respect to biochemical factors as well as mechanical cues. In this first year, we have developed a microbio reactor in which we have grown 3D cultures of neuroblastomas within different environments formed by hydrogels (i.e. matrigel and collagen). The influence of the gel type on neuronal structure, neurite growth and soma size.

DISSERTATIONS

-

SCIENTIFIC PUBLICATIONS

-

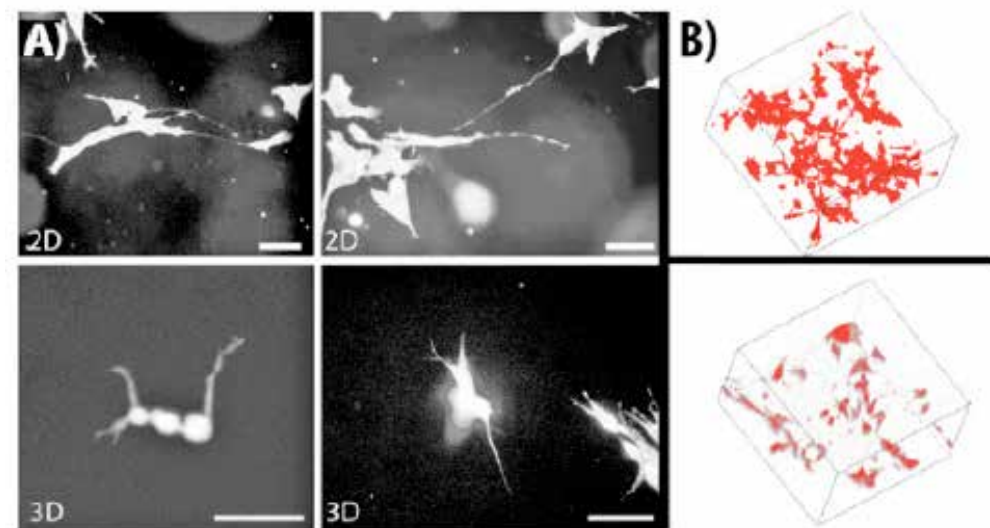

ON-FOIL LARGE-SCALE INTEGRATION AND PACKAGING OF SENSOR FOILS

PROJECT AIM

The project aims to develop the technique based on effective use of capillary self-alignment for low-cost and time-efficient assembly of heterogeneous foil components into a smart electronic identification label. Particularly, we demonstrate the accurate (better than 20 μm) alignment of c sized functional foil dies.

PROGRESS

We experimentally evidenced three sequential, distinct dynamic regimes in the capillary self-alignment of centimeter-sized foil dies released at large uniaxial offsets from equilibrium. We show that the initial transient wetting regime, along with inertia and wetting properties of the dies, significantly affect the alignment dynamics including the subsequent constant acceleration and damped oscillatory regimes. From a practical point of view, full foil-to-foil system integration was demonstrated through the electrically functional assembly of an array of Au-sputtered capacitive sensors onto a patterned base foil circuitry. Finally, the developed technology was extended to enable handling and further assembly of delicate components through capillary grippers, and it was demonstrated that this novel approach enables the system integration by capillary self-alignment of foil dies onto moving substrates and is therefore compatible with an automatic assembly line.

DISSERTATIONS

1. Arutinov, G. (2014). Capillary self-assembly of components for systems-in-foil. Eindhoven: Technische Universiteit Eindhoven.

SCIENTIFIC PUBLICATIONS

1. G. Arutinov, E. C. P. Smits, P. Albert, P. Lambert, M. Mastrangeli, "In-plane mode dynamics of capillary self-alignment", *Langmuir* vol. 30, pp. 13092-13102, 2014.
2. G. Arutinov, M. Mastrangeli, E. C. P. Smits, G. Van Heck, H. FM Schoo, J. M. J. den Toonder, and A. Dietzel. "Shift Dynamics of Capillary Self-Alignment", in *Precision Assembly Technologies and Systems*, pp. 61-68. Springer Berlin Heidelberg, 2014.
3. M. Mastrangeli, G. Arutinov, E.C.P. Smits, P. Lambert (2014), "Modeling capillary forces for large displacements", *Microfluidics and Nanofluidics*, 1-14.

PROJECT LEADERS

JMJ den Toonder, ECP Smits, A Dietzel

RESEARCH THEME

Complex dynamics of fluids

PARTICIPANTS

G Arutinov

COOPERATIONS

Holst Centre/TNO; BEAMS Group, Free University of Brussels

FUNDED

| | |
|-----------------|------|
| University, TNO | |
| University | 50 % |
| FOM | - |
| STW | - |
| NWO Other | - |
| Industry | - |
| TNO | 50 % |
| GTI | - |
| EU | - |
| Scholarships | - |

START OF THE PROJECT

2013

INFORMATION

G Arutinov
040 247 2186
G.Arutinov@tue.nl
www.tue.nl/universiteit/faculiteiten/faculteit-werktuigbouwkunde/onderzoek/research-groups/microsystems/

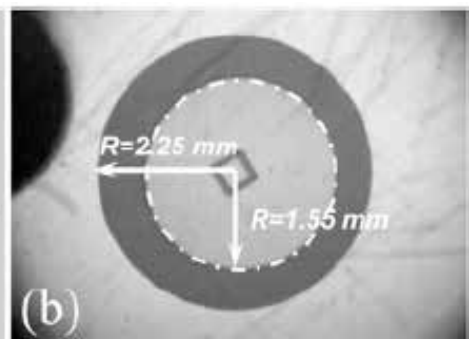
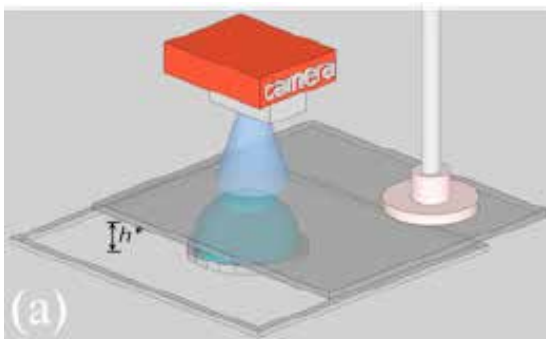

INTEGRATED MICRO-FLUIDIC COOLING IN LAMINATED FLEXIBLE MICRO-SYSTEMS

PROJECT LEADERS

JMJ den Toonder, FGH Homburg,
AJ Frijns

RESEARCH THEME

Complex dynamics of fluids

PARTICIPANTS

D Florea

COOPERATIONS

-

FUNDED

STW

University -

FOM -

STW 100 %

NWO Other -

Industry -

TNO -

GTI -

EU -

Scholarships -

START OF THE PROJECT

2014

INFORMATION

D Florea

040 247 2186

d.florea@tue.nl

www.tue.nl/universiteit/faculiteiten/

faculteit-werktuigbouwkunde/

onderzoek/research-groups/

microsystems/

PROJECT AIM

Due to the combination of the continued miniaturization of microelectronic components on the one hand, and the trend towards flexible electronics (and therefore the use of lower thermal conductivity materials), heat generation in flexible electronics becomes a serious challenge. The aim of this project is to realize and test a pulsating heat pipe that can be used in flexible electronics for cooling of critical components.

PROGRESS

We have realized and tested first prototypes of pulsating heat pipes to study the behavior of PHP's depending on a number of parameters such as design and size of the PHP, and filling ratio. These experiments revealed a number of critical issues that interfere with the proper operation of the PHP, namely dead volume, surface roughness, cross section of the channel, and permeability. On the basis of our findings, a new PHP prototype has been designed and will be tested in the near future.

DISSERTATIONS

-

SCIENTIFIC PUBLICATIONS

-

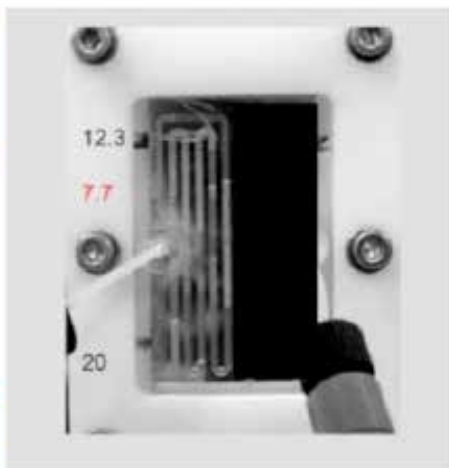
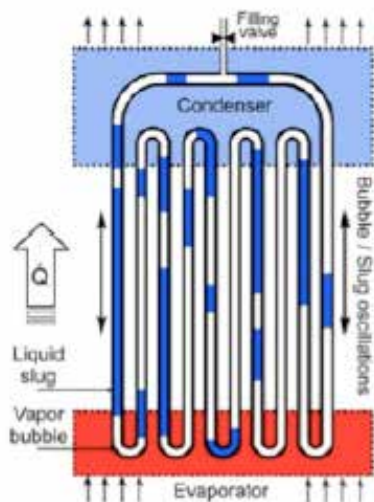

MESOTAS: CHATTING WITH NEURONS

PROJECT AIM

Our aim is to combine microfluidics with tissue engineering to create a 'living' brain, generating realistic in vitro neural circuitry, which can be used to standardize experimental neuronal cell culture. For this, an on-chip bioreactor is fabricated to reproduce the natural 3D neuronal network of the brain in an easy to use in vitro setting. Nanotools are designed to guide neurite outgrowth and biomechanically stimulate this neuronal network. To study brain physiology, these two research fields are combined to biochemically and biomechanically stimulate the neuronal network. In the end, our platform can serve as a model to study and treat the brain disease epilepsy.

PROGRESS

Highly uniform sieving structures (made by corner lithography and silicon wet etching) for single neuron arraying at the interface between electrodes and 3D matrix inside our bioreactor has been developed. We intend to use these structures for hydrodynamic cell capturing (sieves), suitable for integration of electrodes for electrophysiological measurements of neuronal networks. In addition, controlling neurite outgrowth in 3D was also investigated on the nanogrooved surfaces and we report that neurite alignment is still present at 6 μm from the surface, indicating that neurites are able to 'feel' their environment in 3D. To gain knowledge on neuron performances within 3D matrices, the neuroblastoma cell line SH-SY5Y was cultured within different bio gels (Collagen, Matrigel, PuraMatrix) and we demonstrated clear differences between 2D and 3D cultures in terms of cell morphology and amount of neurite outgrowths, with viable 3D cultures lasting up to 21 days.

DISSERTATIONS

-

SCIENTIFIC PUBLICATIONS

1. S Xie and R Luttge (2014). Imprint lithography provides topographical nanocues to guide cell growth in primary cortical cell culture. *Microelectronic Engineering*, 124, 30-36.
2. S Xie, B Schurink, F Wolbers, R Luttge and G Hassink (2014). Nanoscaffold's stiffness affects primary cortical cell network formation. *J. Vac. Sci. Technol. B* 32, 06FD03.
3. M Odijk, AD van der Meer, D Levner, HJ Kim, MW van der Helm, LI Segerink, JP Frimat, GA Hamilton, DE Ingber and A van den Berg (2014). Measuring direct current trans-epithelial electrical resistance in organ-on-a-chip microsystems. *Lab Chip*, 15, 745-752.
4. B Schurink, JW Berenschot, RM Tiggelaar and R Luttge (2014). Highly uniform sieving structure by corner lithography and silicon wet etching. *Microelectronic Engineering*, 144, 12-18.
5. AJ Bastiaens, JP Frimat, MJM den Toonder and R Luttge (2014). Collagen-I / Matrigel hydrogels in different ratios influence neurite growth and cellular morphology in 3D neural culture. *NanoBioTech Montreux, Switzerland*, Nov 17-19.

PROJECT LEADERS

R Luttge, MJM den Toonder

RESEARCH THEME

Complex structures of fluids

PARTICIPANTS

B Schurink, PhD student University of Twente, S Xie, PhD student University of Twente, AJ Bastiaens, PhD student Eindhoven University, JP Frimat, Postdoc University Eindhoven.

COOPERATIONS

Prof. dr. JGE Gardeniers, Mesoscale Chemical Systems, MESA+ Institute for Nanotechnology, University of Twente

FUNDED

European Research Council, ERC, no.280281 MESOTAS

| | |
|--------------|-------|
| University | - |
| FOM | - |
| STW | - |
| NWO Other | - |
| Industry | - |
| TNO | - |
| GTI | - |
| EU | 100 % |
| Scholarships | - |

START OF THE PROJECT

2011

INFORMATION

R Luttge
040 247 5235
r.luttge@tue.nl
www.tue.nl/en/university/departments/mechanical-engineering/the-department/staff/detail/ep/e/d/ep-uid/20135203/

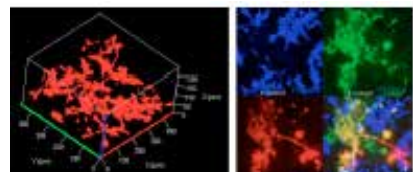

DYNACLEAN: DYNAMIC SELF-CLEANING SURFACES ENABLED BY RESPONSIVE MATERIALS

PROJECT LEADERS

JMJ den Toonder

RESEARCH THEME

Complex dynamics of fluids

PARTICIPANTS

GG Melpignano, E de Jong,
PR Onck, MJM den Toonder

COOPERATIONS

Philips Research, RUG

FUNDED

STW

University -

FOM -

STW 100 %

NWO Other -

Industry -

TNO -

GTI -

EU -

Scholarships -

START OF THE PROJECT

2013

INFORMATION

GG Melpignano

040 247 4905

g.g.melpignano@tue.nl

www.tue.nl/universiteit/faculiteiten/

faculteit-werktuigbouwkunde/

onderzoek/research-groups/

microsystems/

PROJECT AIM

Self-cleaning surfaces are interesting for applications in e.g. lighting, healthcare, personal care products and solar cells. Inspired by nature, current man-made self-cleaning surfaces have permanent micro- and nano-structures. However, these are static and thus vulnerable to contamination and damage. The goal of this work is to create dynamic self-cleaning surfaces, switchable between self-cleaning and non-cleaning by means of (an) external trigger(s).

PROGRESS

Hierarchical micrometer sized base features with nanometer roughness are created, between which a thermo-responsive hydrogel (pNIPAM) is placed. The hydrogel changes its chemical and structural properties upon the additional of water and heat. When at a low temperature, the thermo-responsive hydrogel is hydrophilic (in favor of water), whilst at a high temperature it is hydrophobic. This results in swelling of the hydrogel when in contact with water for low temperature, whilst expelling water for higher temperatures. The swelling of the structured surface has been investigated. It is found that swelling of 20 μm in height occurs for lateral spaced dimensions of 20 μm (200% increase between dry and wet). The water repellency has been measured using contact-angle measurements. Switching in the water repelling properties as a function of temperature has been found.

DISSERTATIONS

-

SCIENTIFIC PUBLICATIONS

-

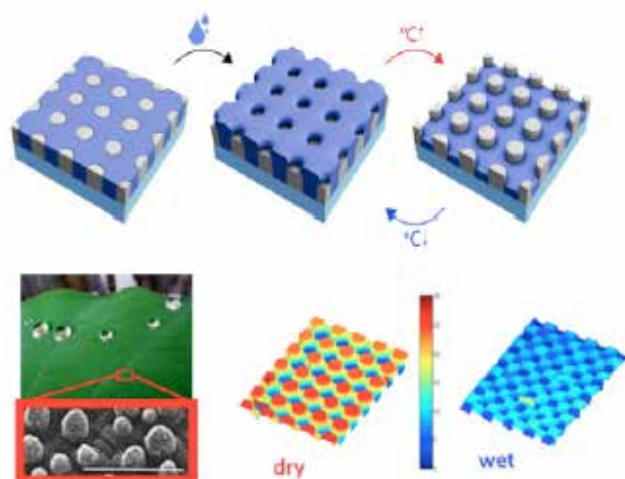

HETEROGENEOUS SENSOR SYSTEMS ON FOIL

PROJECT AIM

Develop basic functions and manufacturing processes for realizing microfluidics-based sweat sensing micro systems which combine the strengths of foil and Si technology.

PROGRESS

We have analyzed the evaporation behavior which is used for the pumping mechanism of the sweat sensing system on a flexible substrate. The influences of environmental and structural parameters were studied for control the pumping behavior. Good agreements between the evaporation theory and experimental flow rate were found. The final step is bonding or/and printing the chip for the entire system and testing for a final sweat sensing product.

DISSERTATIONS

-

SCIENTIFIC PUBLICATIONS

1. Nie, C., Frijns, A.J.H., Mandamparambil, R. & Toonder, J.M.J. den (2014). Influence of temperature on the performance of an evaporation driven micro pump. In S Colin, G.L. Morini, JJ Brandner & D Newport (Eds.), Conference Paper : Proceedings of the 4th European Conference on Microfluidics, 10-12 December 2014, Limerick, Ireland, (pp. μ FLU14-18). SHF.
2. Nie, C., Mandamparambil, R., Frijns, A.J.H. & Toonder, J.M.J. den (2014). An evaporation driven pump for microfluidics applications. In L. Tadrast & I. Graur (Eds.), Proceedings of the 5th International Conference on Heat Transfer and Fluid Flow in Microscale (HTFFM-V), 22-25 April 2014, Marseille, France, Marseille: ECI.

PROJECTLEADERS

JMJ den Toonder, AJH Frijns

RESEARCHTHEME

Complex structures of fluids

PARTICIPANTS

C Nie, A Frijns, R Mandamparambil

COOPERATIONS

Holst Centre, Eindhoven

FUNDED

NanoNextNL
University -
FOM -
STW -
NWO Other 100 %
Industry -
TNO -
GTI -
EU -
Scholarships -

START OF THE PROJECT

2011

INFORMATION

C Nie
040 247 3647
c.nie@tue.nl
www.tue.nl/universiteit/faculteiten/faculteit-werktuigbouwkunde/onderzoek/research-groups/microsystems/research/microsystems-applications/chuan/

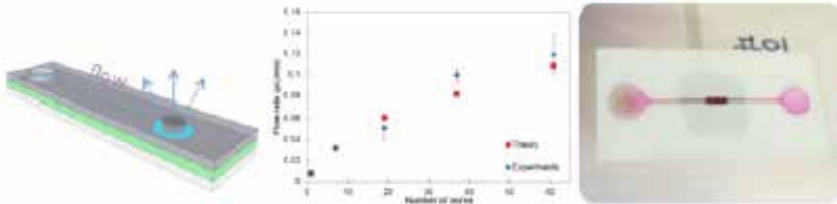

BIOCHIP DESIGN FOR ALGAE MONITORING

PROJECT LEADERS

Y Bellouard, JMJ den Toonder

RESEARCH THEME

Complex structures of fluids

PARTICIPANTS

A Schaap

COOPERATIONS

Norwegian Water Research Institute

FUNDED

Eindhoven University of Technology's

Dept. of Mechanical Engineering

EC Project "Femtoprint" (FP7)

University 90 %

FOM -

STW -

NWO Other -

Industry -

TNO -

GTI -

EU 10 %

Scholarships -

START OF THE PROJECT

2010

INFORMATION

A Schaap

040 247 3647

a.schaap@tue.nl

tue.nl/microsystems

PROJECT AIM

The identification of algae species is useful and important for monitoring water quality and conditions for health and environmental applications. This project aims to develop a chip-based approach to identifying and classifying algae species in water in real-time, using microfluidics with integrated optical and/or other sensors. We use a femtosecond laser to create microchannels and optical waveguides in fused silica, to create integrated optofluidic microdevices on a single substrate.

PROGRESS

This year the focus was on numerical and experimental studies of two methods of sorting algae cells by size and shape in microfluidic channels. We tested the use of both optical and fluidic forces for this task. The optical method uses an optical gradient to move particles across streamlines. The fluidic method relies on the balance of inertial forces and drag forces from Dean flow in a spiral microchannel to sort the algae cells by size and shape.

Besides this, we also did characterization studies on the optical algae identification system developed previously, particularly looking at the effects of increasing the flow rate in the device. For example, we examined the effect of flow rate on the self-alignment of high aspect ratio particles in the flow, and on the sensitivity of the device when used as a particle counter.

DISSERTATIONS

-

SCIENTIFIC PUBLICATIONS

-

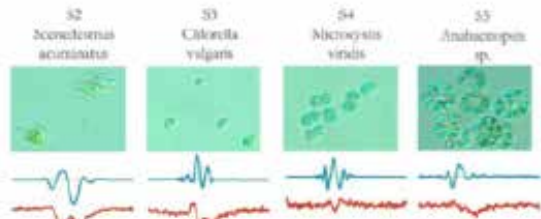
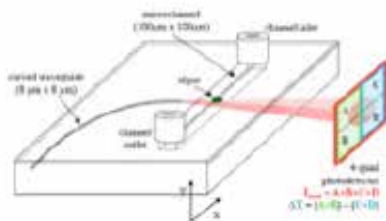

GAS SENSOR MEMBRANE

PROJECT AIM

The PASTEUR project aims to build a disposable tag for food monitoring. Our work focusses on a membrane that will be used to enhance the functionality of the micro-scale gas sensors. The membrane will block solid particles and droplets and remove them from the sensor surface while still allowing the target gas to be transported to the sensor. Additionally it will enhance both the sensitivity and selectivity of the sensor using a perm-selective membrane in combination with a pumping system.

PROGRESS

Experiments were carried out to modify a PDMS surface. By tuning the ablation parameters, we could make it sticky or slippery super-hydrophobic. These surfaces were characterized using SEM, Raman spectroscopy and static and dynamic contact angle measurements. We created a pattern that acted as a drop merger, drop size could be tuned by choosing the tilting angle. We also created a pattern that acted as a drop container. An oxygen concentration sensor was installed on the setup.

DISSERTATIONS

-

SCIENTIFIC PUBLICATIONS

1. Pelt, S. van, Frijns, A.J.H., Mandamparambil, R. & Toonder, J.M.J. den (2014). Local wettability tuning with laser ablation redeposits on PDMS. Applied Surface Science, 303, 456-464.

PROJECT LEADERS

JMJ den Toonder, AJH Frijns

RESEARCH THEME

Complex structures of fluids

PARTICIPANTS

S van Pelt

COOPERATIONS

Holst Centre

FUNDED

CATRENE, PASTEUR

University -

FOM -

STW -

NWO Other -

Industry -

TNO -

GTI -

EU 100 %

Scholarships -

START OF THE PROJECT

2009

INFORMATION

S van Pelt

040 247 2186

s.v.pelt@tue.nl

www.tue.nl/en/university/departments/mechanical-engineering/research/research-groups/research-group-microsystems/research/microsystems-applications/gas-sensor-window/

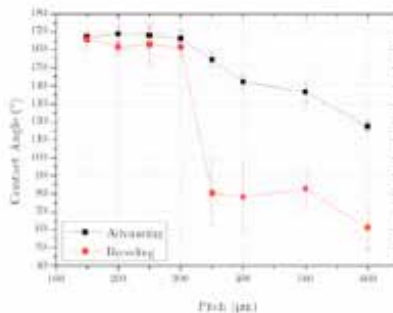

BIO-INSPIRED HAIRY SURFACES FOR ACTUATION OR SENSING, PRODUCED WITH ROLL-TO-ROLL TECHNOLOGY

PROJECT LEADERS

JMJ den Toonder, PD Anderson

RESEARCH THEME

Complex structures of fluids

PARTICIPANTS

Y Wang

COOPERATIONS

-

FUNDED

DPI

University -

FOM -

STW -

NWO Other -

Industry -

TNO -

GTI -

EU 100 %

Scholarships -

START OF THE PROJECT

2011

INFORMATION

Y Wang

040 247 5706

y.wang2@tue.nl

www.tue.nl/universiteit/faculiteiten/

faculteit-werktuigbouwkunde/

onderzoek/research-groups/

microsystems/

PROJECT AIM

This project aims to develop novel out-of-cleanroom technologies for manufacturing magnetically actuated artificial cilia. These cilia are integrated into microfluidic systems, and the flow generated by the cilia, actuated with an externally applied magnetic field, is characterized.

PROGRESS

After introducing a first fabrication method for magnetic artificial cilia, based on the self-assembly of magnetic microbeads in a magnetic field (published in Lab on a Chip), we developed a second method based on the formation of magnetic fibers from a precursor of PDMS containing magnetic particles, using a field created by a magnetic field. Flow velocities of 70 $\mu\text{m/s}$ could be generated with these cilia. The results were reported in a paper accepted by Microfluidics Nanofluidics. Then, we built a roll-pulling device that could be used to create magnetic artificial cilia (based on PDMS with superparamagnetic microbeads) on large areas. These cilia, when integrated in a microfluidic device, could generate flow velocities of over 100 $\mu\text{m/s}$.

DISSERTATIONS

-

SCIENTIFIC PUBLICATIONS

-

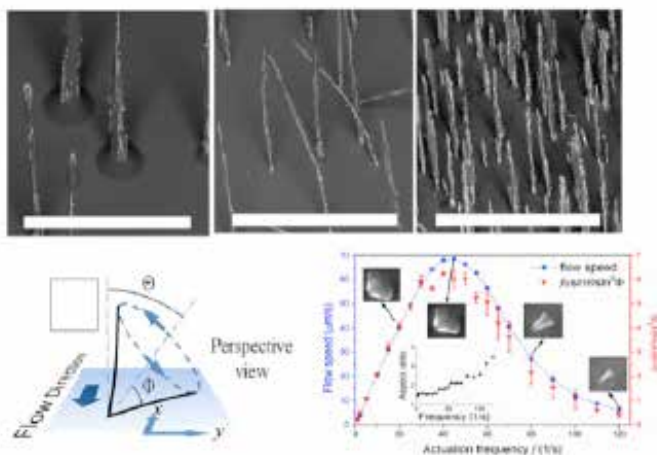



Prof.dr.ir. EH van Brummelen

The Multiscale Engineering Fluid Dynamics section of the Mechanical Engineering Department at TU Eindhoven has been established in 2009 within the framework of the 3TU Centre of Excellence for Multiscale Phenomena. The MEFD section focuses on the development, analysis and application of mathematical-physical models and advanced numerical techniques for multiscale flow problems in engineering applications, with particular emphasis on interface and free-boundary problems, flow problems in the transitional molecular/continuum regime and auxiliary field interactions, such as fluid-structure interaction. The research in the section has an underpinning and methodological character, while maintaining a strong connection to applications in the high-tech industry and in other sections at TU/e.

ADAPTIVE MOMENT-CLOSURE APPROXIMATIONS OF THE BOLTZMANN EQUATION

PROJECT AIM

The aim of this project is to create a paradigm for adaptive hierarchical moment-closure approximations of the Boltzmann equation.

PROGRESS

A new moment-closure hierarchy has been formulated, which preserves the fundamental structural properties of the Boltzmann equation (conservation of mass, momentum and energy; Galilean invariance; dissipation of an entropy functional; representation of equilibrium distributions), which yields finite fluxes in the vicinity equilibrium, and which facilitates the computation of fluxes. The baseline implementation of higher-order systems in 1D has been completed. An article on the formulation has been submitted. Extension to multi-D and implementation of an adaptive procedure are currently in progress.

DISSERTATIONS

-

SCIENTIFIC PUBLICATIONS

-

PROJECT LEADERS

EH van Brummelen

RESEARCH THEME

Mathematical and computational methods for fluid flow analysis

PARTICIPANTS

MRA Abdel Malik, EH van Brummelen

COOPERATIONS

M Torrilhon (RWTH Aachen)

FUNDED

| | |
|--------------|-------|
| TU/e | |
| University | 100 % |
| FOM | - |
| STW | - |
| NWO Other | - |
| Industry | - |
| TNO | - |
| GTI | - |
| EU | - |
| Scholarships | - |

START OF THE PROJECT

2011

INFORMATION

EH van Brummelen

040 2475470

e.h.v.brummelen@tue.nl

www.tue.nl/vanbrummelen

NUMERICAL SIMULATION OF DROP FORMATION AND DYNAMICS IN PICOLITER JETTING TECHNOLOGY

PROJECT LEADERS

EH van Brummelen

RESEARCH THEME

Mathematical and computational methods for fluid flow analysis

PARTICIPANTS

M Shokrpour Roudbari, G Simsek,
G van Zwieten, EH van Brummelen,
HMA Wijshoff, KG van der Zee

COOPERATIONS

KG van der Zee (Univ Nottingham)

FUNDED

| | |
|------------------|------|
| NanoNextNL (FES) | |
| University | 25 % |
| FOM | - |
| STW | - |
| NWO Other | - |
| Industry | 75 % |
| TNO | - |
| GTI | - |
| EU | - |
| Scholarships | - |

START OF THE PROJECT

2011

INFORMATION

EH van Brummelen
040 2475470
e.h.v.brummelen@tue.nl
www.tue.nl/vanbrummelen

PROJECT AIM

This project aims at the development of a computational platform to simulate the ejection of liquid droplet in the 1 picoliter regime from a micro nozzle. On account of the very small scales, it is necessary to include the interaction of the droplet with the surrounding air and to ensure a very precise representation of surface/interface effects. This requirement calls for advanced moving-mesh techniques. In addition, contact-line effects must be properly included.

PROGRESS

The simulation model is based on the Cahn-Hilliard-Navier-Stokes diffuse-interface model for two phase flows. In subproject 1, numerical results have been obtained for the Cahn-Hilliard equations separately with special boundary conditions to model wetting behavior on solid substrates. Moreover, a baseline model for the CHNS equations for non-matched densities has been implemented. Further investigation of the time-discretization procedure and the iterative method are required. In subproject 2, a paper on adaptivity has been published (to appear in 2015), and a structure preserving CHNS formulation and time-integration procedure have been developed.

DISSERTATIONS

-

SCIENTIFIC PUBLICATIONS

-



Prof.dr.ir. FN van de Vosse

The Cardiovascular Biomechanics group at the department of Biomedical Engineering aims to promote the use of experimentally validated predictive mathematical modeling, both in diagnosis and selection of therapy in clinical practice as well as in research and development in the medical device industry. The research in the group is divided in 4 areas of which the first is embedded in JMBC.

1. HEMODYNAMICS

Hemodynamic factors such as like local pressure, velocity, wall shear stress and wall deformation are crucial for the proper functioning of the vascular system, the heart and its native valves. These factors play a key role in the genesis of vascular disease and, when measured properly, can also be predictive for the development of cardiovascular disease. Hemodynamics research in the group is focused on the development of mathematical models and the corresponding computational methods based on finite and spectral element approximations. These models are used to understand the functioning and response of the cardiovascular system. The models range from 0D lumped parameter and 1D wave propagation models of the entire cardiovascular system to 3D models of local fluid-structure interaction in specific arterial segments and heart valve dynamics. Both microscopic (blood as a suspension) as well as macroscopic (blood-wall interaction) scales are considered. In vitro laboratory experiments and measurement techniques are designed and used to validate the outcome of the computational simulations.

2. MECHANICS AND ADAPTATION

Cardiovascular mechanics research is focused on the understanding of the mechanical response of vascular and cardiac tissue to mechanical loads, caused by the pulse wave propagation and cardiac contraction, as well as external forces caused by medical interventions.

3. INSTRUMENTATION AND DEVICES

Medical instrumentation and devices like ultrasound image modalities, pressure and flow sensors, particularly those used for advanced diagnostic measurements.

4. CLINICAL RESEARCH

Through pilot or full clinical studies, in which patient data are gathered and used as input for patient specific modelling, evaluation of the predictive value of mathematical models to predict outcome of medical intervention can be performed.

RHEOLOGY OF BLOOD CLOT FORMATION

PROJECT AIM

Blood clots form upon vascular injury in order to prevent blood loss and are involved in the process of wound healing. The structure of the blood clot plays a role in many pathologies and is influenced by the flow conditions under which the clot develops. However, the relation between structural properties influenced by the flow and the macroscopic mechanical properties of the clot is poorly understood. In this project constitutive equations are developed based on the structural properties of the different constituents of the clot to study its mechanical properties under various conditions.

PROGRESS

One of the main structural components of the blood clot is fibrin, a protein that forms a fibrous structure within the blood clot. A constitutive model is developed that describes the formation of the fibrin network in time. The network formation is modeled as a transition from a viscous fluid to a viscoelastic solid, where the transition is governed by the fibrin kinetics. The model is extended by taking into account the non-linear viscoelastic behavior of the network. The strain-stiffening behavior observed in large deformations is incorporated in the solid phase of the model. As validation, rheometry experiments are performed where a fibrin network is formed within the rheometer. Quantitative agreement is found between the model and experimental results. This project has been finished.

DISSERTATIONS

-

SCIENTIFIC PUBLICATIONS

-

PROJECTLEADERS

FN van de Vosse, GWM Peters

RESEARCHTHEME

Complex structures of fluids

PARTICIPANTS

THS van Kempen

COOPERATIONS

TU/e Mechanical Engineering

TU/e Applied Physics

FUNDED

TU/e High Potential Research

Program: Blood in Motion

University 100 %

FOM -

STW -

NWO Other -

Industry -

TNO -

GTI -

EU -

Scholarships -

START OF THE PROJECT

2011

INFORMATION

THS van Kempen

t.h.s.v.kempen@tue.nl

CONTINUUM MODELLING OF BLOOD CLOT FORMATION AND GROWTH

PROJECT LEADERS

FN van de Vosse

RESEARCH THEME

Complex dynamics of fluids

PARTICIPANTS

F Storti

COOPERATIONS

TU/e Mechanical Engineering

TU/e Applied Physics

FUNDED

TU/e High Potential Research

Program: Blood in Motion

University 100 %

FOM -

STW -

NWO Other -

Industry -

TNO -

GTI -

EU -

Scholarships -

START OF THE PROJECT

2010

INFORMATION

F Storti

f.storti@tue.nl

PROJECT AIM

Hemostasis is the complex process necessary to prevent blood loss. It involves the interplay between biochemical and physical processes, which normally keep the blood in a fluidic state and repair the walls of veins and arteries in case of injury. When this happens a blood clot forms around the injury. The phenomenon of blood clotting mainly consists of two mechanisms:

1. dynamics of platelet and chemical species;
2. clot growth and remodelling.

The aim of the project is to create a mathematical model that describes the blood clot formation and growth. Particular attention is given to the interaction between the blood flow and the porous clot.

PROGRESS

The initial formation of the clot is modelled through a system of convection-diffusion-reaction equations. Unactivated platelets, activated platelets, chemical activators and chemical inhibitors are modelled as concentrations. All these factors represent the onset of the coagulation process. Once the clot is formed, it is represented by means of an elastic solid, which interacts with the flow around it through basic FSI. The clot growth is represented by mesh update (ALE method) and once in a while remeshing is necessary. To represent the porosity of the clot a Brinkman term is included in the Navier-Stokes equations for the fluid and the elastic solid is modified into a porous elastic solid. This project has been finished.

DISSERTATIONS

-

SCIENTIFIC PUBLICATIONS

-

PROBING RED BLOOD CELL MECHANICS

PROJECT AIM

Because of the high volume contents of red blood cells (RBCs) in blood, mechanics of a single RBC plays a large role in plasma mixing and lateral transport of its components. Therefore, a characterization of the dynamical parameters of RBCs under different flow conditions is needed. Our strategy involves estimation of mechanical properties of the RBC using an inverse analysis which combines both numerical and experimental tools. A RBC is deformed under elongational flow. Advantage of this experimental method is that there is no contact between a solid and the cell membrane, which would complicate the analysis, especially during dynamic deformations. To create a setup with elongational flow, a cross-slot microfluidics device is built (left figure). Rigid channels in SU-8 photoresist on glass are sealed with a PDMS foil. The foil also serves as a deflecting membrane for the valves, which enable position control of the cell. Piezo-electric elements are used in closed loop control to actuate the valves. To change the stress on the RBC dynamically, a pulsatile microfluidics pump is designed, built, and tested.

PROGRESS

Active repositioning of the cell is necessary to perform repetitive measurements. However, a linear feedback loop seems to be inadequate. For the design of a suitable feedback system with feedforward control, a numerical tool is developed. This involves 2D FEM simulations of the cross-slot (Stokes flow), in which lumped parameter models that represent the channel hydraulics, are added to the boundary conditions of the in- and outflow channels. By matching the experimental open-loop system identification measurements with the simulations, the parameters for the lumped elements are fitted. Hence, this hybrid model is used as a platform to design a non-linear controller. This project has been finished.

DISSERTATIONS

-

SCIENTIFIC PUBLICATIONS

-

PROJECTLEADERS

FN van de Vosse, ACB Bogaerds,
PD Anderson

RESEARCHTHEME

Complex dynamics of fluids

PARTICIPANTS

RCH van der Burgt

COOPERATIONS

TU/e Mechanical Engineering

TU/e Applied Physics

FUNDED

TU/e High Potential Research

Program: Blood in Motion

University 100 %

FOM -

STW -

NWO Other -

Industry -

TNO -

GTI -

EU -

Scholarships -

START OF THE PROJECT

2009

INFORMATION

R van der Burgt

r.c.h.v.d.burgt@tue.nl

PROJECT LEADERS

FN van de Vosse, MA Hulsen
ACB Bogaerds

RESEARCH THEME

Mathematical and computational
methods for fluid flow analysis

PARTICIPANTS

AC Verkaik

COOPERATIONS

TU/e Mechanical Engineering

FUNDED

TU/e

University 100 %

FOM -

STW -

NWO Other -

Industry -

TNO -

GTI -

EU -

Scholarships -

START OF THE PROJECT

2008

INFORMATION

AC Verkaik

A.C.Verkaik@tue.nl

PROJECT AIM

Distal to artificial heart valves transitional (transition to turbulence) flow with small scale local velocity fluctuations can be found. To compute transitional flow spectral elements can be used, however we also want to compute accurately the fluid stress near the deforming structure. Therefore, this study will focus on the implementation of a coupling method between spectral and finite elements to compute fluid-structure interaction for transitional flow through artificial heart valves.

PROGRESS

In previous periods we proposed a fully Coupled Overlapping Domain (COD) method to couple the fixed grid fluid domain with an Arbitrary Lagrangian Eulerian (ALE) moving grid fluid domain. This allows for an optimal conformal coupling between the fluid elements and the structural elements. The convergence of the spectral elements was proved. Last year we focused on testing the fluid-fluid coupling of the COD method for several benchmark problems and some first test problems with fluid-structure interaction were made. This project has been finished.

DISSERTATIONS

-

SCIENTIFIC PUBLICATIONS

-

CENTRE FOR ANALYSIS, SCIENTIFIC COMPUTING AND APPLICATIONS (CASA)



Prof.dr.ir. B Koren



Prof.dr.ir. F Toschi

TU/e's Centre for Analysis, Scientific Computing and Applications (CASA) embodies the chairs Applied Analysis and Scientific Computing, which both participate in the J.M. Burgerscentrum.

CASA's research objective is to develop new and improve existing mathematical methods - both analytical and numerical - for a wide range of applications in science and engineering. Extensive collaborations exist with researchers in other disciplines, at universities, large technological institutes as well as industries, both nationally and internationally. Current CASA research related to fluid dynamics concerns aerodynamics, aeroacoustics, magnetohydrodynamics, fluid-structure interactions, porous media flows, viscous and viscoelastic flows, free-surface flows, particle flows and shape optimization.

COMPARISON BETWEEN HYPERVELOCITY IMPACT OF PARTICLES AND PULSED LASER THERMAL IMPACT MODELS ON GLUE BONDED LAMINATES UNDER CRYOGENIC CONDITIONS

PROJECT AIM

The final goal of this project is to study hypervelocity impacts into laminated materials. For that purpose we extend the capabilities of the Smoothed Particle Hydrodynamics (SPH) method, modify existing algorithms and create a computational tool.

PROGRESS

In the last period, our efforts were targeted towards three directions. Firstly, we finalized our SPH computational tool (LimeSPH) for the simulation of hypervelocity impacts into inhomogeneous materials and multiphase compressible processes in general. We validated and presented our results regarding improvements of the SPH method and hypervelocity impacts into inhomogeneous structures. Comparison of our results with results obtained with the ALE method is in continuing collaboration with the Laboratory of Mechanics, at the University of Lille in France. Secondly, in collaboration with the mathematical analysis group of CASA, we made an analytical/numerical study, which resulted in a proof of the convergence of the SPH method. Thirdly, through our contacts with ESA/ESTEC, we performed hypervelocity impact experiments at the Fraunhofer Ernst Mach Institute in Freiburg, Germany. The impacted specimens were laminated materials, which we made at the facilities of FMLC at TU Delft.

DISSERTATIONS

-

SCIENTIFIC PUBLICATIONS

1. I.Zisis, B. van der Linden, C.Giannopapa, J.A.M. Dam; SPH for hypervelocity impacts into inhomogeneous materials; Proceedings of the 2014 ASME Pressure Vessels & Piping Conference PVP-2014, Anaheim-CA, USA.
2. I.Zisis, B. van der Linden, R. Messahel, M.Souli, B.Koren; Two-phase benchmarks for SPH multiphase fully compressible schemes; 9th International SPHERIC workshop, Paris-France.

PROJECT LEADERS

B Koren

RESEARCH THEME

Mathematical and computational methods for fluid flow analysis

PARTICIPANTS

I Zisis, BJ van der Linden

COOPERATIONS

Laboratory of Mechanics, Lille-France, Applied Analysis chair, CASA, TU/e, Institute of High Speed Dynamics, Fraunhofer EMI Freiburg-Germany, FLMC, TU Delft

FUNDED

Materials Innovation Institute m2i and Laboratory for Industrial Mathematics Eindhoven, LIME BV.

University 75 %

FOM -

STW -

NWO Other -

Industry 25 %

TNO -

GTI -

EU -

Scholarships -

START OF THE PROJECT

2011

INFORMATION

I Zisis

i.zisis@tue.nl

PROJECT LEADERS

SW Rienstra, JJM Slot

RESEARCH THEME

Mathematical and computational methods for fluid flow analysis

PARTICIPANTS

D Kumar Singh

COOPERATIONS

FLOWAIRS-(Acoustics Laboratory of the Université du Maine-France)

FUNDED

Marie Curie ITN (EU-FP7)

University -

FOM -

STW -

NWO Other -

Industry -

TNO -

GTI -

EU 100 %

Scholarships -

START OF THE PROJECT

2012

INFORMATION

D Kumar Singh

040 247 5865

d.k.singh@tue.nl

www.win.tue.nl/~sjoedr/

PROJECT AIM

The project mainly concerns the mathematical modelling of sound absorbing lining material (physically correct descriptions in time domain; thermo-viscous effects of liners consisting of stacked pores; the coupling with an unstable boundary layer), and the effect of the boundary layers on the sound produced by the flow.

PROGRESS

Experimental observation of a hydrodynamic mode in a flow duct with a porous material: This work investigates experimentally the acoustic behaviour of a homogeneous porous material with a rigid frame (metallic foam) under grazing flow. The transmission coefficient shows an unusual oscillation over a particular range of frequencies which reports the presence of an unstable hydrodynamic wave that can exchange energy with the acoustic waves. This characteristic behaviour is reported in JASA.

Hard wall - soft wall - vorticity scattering in shear flow: This work presents a canonical model for the vorticity scattering in incompressible turbulent flow with linear shear as it passes a hard-to-soft-wall transition. The incompressible near field solution, obtained by the Wiener Hopf technique, is matched to the acoustic far field. The scattered sound is found to depend strongly on the flow shear/frequency rate being higher or lower than unity. It is found to be most intense for high shear. Further analysis of the limit Z (impedance) = 0 is in progress, in order to obtain further insight in the problem.

DISSERTATIONS

-

SCIENTIFIC PUBLICATIONS

1. Non-linear asymptotic Impedance model for a Helmholtz resonator liner, with Sjoerd W. Rienstra. *Journal of Sound and Vibration*, volume 333, issue 15, 21 July 2014, pp. 3536-3549.
2. Experimental observation of a hydrodynamic mode in a flow duct with porous material, with Yves Auregan, *Journal of the Acoustical Society of America*, JASA, 136, 567 (2014).
3. Hard wall - soft wall - vorticity scattering in shear flow, with Sjoerd W. Rienstra. AIAA 2014-3350, 20th AIAA/CEAS Aeroacoustics Conference, 16-20 June 2014, Atlanta, Georgia, USA.

SOUND PROPAGATION IN A DUCT WITH SHEARED FLOW AND NON-LOCALLY REACTING LINERS

PROJECT AIM

The goal of the project is to further develop and make available a class of semi-analytical solutions (based on modes) for the propagation and attenuation of sound in flow ducts, aiming in particular at the reduction of noise from the auxiliary power unit (APU, a turbine engine) of aircraft. Here, the walls of the duct are covered with acoustically damping material, i.e. non-locally reacting liners (e.g. metallic foam). Furthermore, the mean flow exhibits strong shear and temperature gradients. Keywords: duct acoustics, aeroacoustics.

PROGRESS

The project has successfully been finished by the defense of a PhD-thesis.

DISSERTATIONS

1. "Sound Propagation in Lined Ducts with Parallel Flow" by Martien Oppeneer, 30 June 2014, from Technische Universiteit Eindhoven. 1e promotor R.M.M Mattheij, 2e promotor B. Koren, copromotor S.W. Rienstra.

SCIENTIFIC PUBLICATIONS

-

PROJECTLEADERS

SW Rienstra, P Sijtsma, RMM Mattheij

RESEARCHTHEME

Mathematical and computational methods for fluid flow analysis

PARTICIPANTS

P Sijtsma (supervisor NLR), SW Rienstra (supervisor), RMM Mattheij (promotor), M Oppeneer (PhD-student)

COOPERATIONS

Airbus

FUNDED

National Aerospace Laboratory NLR
University -
FOM -
STW -
NWO Other -
Industry -
TNO -
GTI 100 %
EU -
Scholarships -

START OF THE PROJECT

2009

INFORMATION

SW Rienstra
s.w.rienstra@tue.nl
040 2474603
<http://www.win.tue.nl/~sjoerdr/>

CONSTITUTIVE MODELING OF ARBITRARY BRANCHED POLYMER MELTS

PROJECT LEADERS

JJM Slot

RESEARCH THEME

Complex dynamics of fluids

PARTICIPANTS

V Shchetnikava

COOPERATIONS

Prof.dr.ir. E. van Ruymbeke, UCL, Belgium, Prof.dr. P.D. Iedema, UvA

FUNDED

Dutch Polymer Institute (DPI)

University -

FOM -

STW -

NWO Other 100 %

Industry -

TNO -

GTI -

EU -

Scholarships -

START OF THE PROJECT

2009

INFORMATION

JJM Slot

040 247 4381

j.j.m.slot@tue.nl

PROJECT AIM

The primary objective of this project is to develop a molecularly based constitutive model for the rheological behavior of polymer melts consisting of arbitrary branched polymer molecules. An industrially relevant example of such a system is a melt of low-density polyethylene (LDPE). As such a system shows an extreme variation in molecular composition, a description of this composition can only be given in statistical terms. Hence, the idea is to describe such a system by a finite set (ensemble) of representative molecular structures (topologies). This part of work on kinetic modeling is done at the University of Amsterdam in a twin PhD project (not part of the JMBC).

PROGRESS

In 2014 we have continued our research on the modification of the time-marching algorithm (TMA) (van Ruymbeke et al., 2005, 2010) for predicting the linear viscoelasticity of polymer melts consisting of well described molecules. We have published our results for the case of monodisperse symmetric stars, where we have validated the TMA model and, for the first time, compared it to the so-called BoB model (Das et al., 2006). Also, we investigated and modelled the viscoelastic properties of binary blends composed of linear chains. These systems are indeed very suitable to test the validity and the limit of the constraint release (CR) process and dynamic tube dilution and to determine the value of the dynamic dilution exponent α . We have validated the TMA model for the case of symmetric h-polymers and, as a result, indicated the significant differences between the TMA and BoB approaches, which mainly affect the choice of material parameters of the models.

DISSERTATIONS

-

SCIENTIFIC PUBLICATIONS

1. Shchetnikava, V., Slot, J.J.M. & Ruymbeke, E. van (2014). A comparison of tube model predictions of the linear viscoelastic behavior of symmetric star polymer melts. *Macromolecules*, 47 (10), 3350-3361. doi: 10.1021/ma500275t.
2. E.van Ruymbeke, V.Shchetnikava, Y. Matsumiya and H.Watanabe (2014). Dynamic Dilution Effect in Binary Blends of Linear Polymers with Well-Separated Molecular Weights. *Macromolecules*, 47 (21), 7653-7665, doi: 10.1021/ma501566.

PROJECT AIM

The project is primarily aimed towards developing sophisticated numerical techniques for studying the flow of incompressible fluids. The developed numerical methods will be used for investigating turbulent wind farm wakes and for designing optimal wind farms.

PROGRESS

We have developed a finite-volume discretization method for the incompressible Navier-Stokes equations. The method computes cell-face velocities involved in the convective flux terms by solving local boundary value problems. Thus we get a sub-cell resolution of the flow, allowing for coarser grids. The developed method was then used to study some flow problems.

DISSERTATIONS

-

SCIENTIFIC PUBLICATIONS

1. Kumar, N., ten Thije Boonkkamp, J.H.M., Koren, B.: A new discretization method for the convective terms in the incompressible Navier-Stokes equations. Finite Volumes for Complex Applications VII - Methods and Theoretical Aspects, pp. 363-371. Springer, Berlin (2014).
2. Kumar, N., ten Thije Boonkkamp, J.H.M., Koren, B.: A sub-cell discretization method for the convective terms in the incompressible Navier-Stokes equations. Submitted at the International Conference on Spectral and High Order Methods (ICOSAHOM) 2014, Salt Lake City, Utah.

PROJECT LEADERS

B Koren, JHM ten Thije Boonkkamp

RESEARCH THEME

Mathematical and computational methods for fluid flow analysis

PARTICIPANTS

N Kumar

COOPERATIONS

EuroTech partners TU/e (EPFL, TU Denmark, TU München)

FUNDED

Shell-NWO-FOM Programme
Computational Sciences for Energy Research

| | |
|--------------|-------|
| University | - |
| FOM | 100 % |
| STW | - |
| NWO Other | - |
| Industry | - |
| TNO | - |
| GTI | - |
| EU | - |
| Scholarships | - |

START OF THE PROJECT

2013

INFORMATION

N Kumar

040 247 8190

n.kumar@tue.nl

www.tue.nl/en/university/departments/mathematics-and-computer-science/the-department/staff/detail/ep/e/d/ep-uid/20134132/

CONTROL AND MITIGATION OF EDGE LOCALIZED MODES BY FURTHER DEVELOPMENT AND APPLICATION OF COMPUTATIONAL TOOLS

PROJECT LEADERS

B Koren, H.J. de Blank

RESEARCH THEME

Mathematical and computational methods for fluid flow analysis

PARTICIPANTS

B van Es

COOPERATIONS

FOM-DIFFER, CWI

FUNDED

FOM (FOM Program 120, "Active Control of Magnetic Hydrodynamic Modes in Burning Plasmas")

| | |
|--------------|-------|
| University | - |
| FOM | 100 % |
| STW | - |
| NWO Other | - |
| Industry | - |
| TNO | - |
| GTI | - |
| EU | - |
| Scholarships | - |

START OF THE PROJECT

2010

INFORMATION

B van Es

020 592 4166

b.van.es@cw.nl

PROJECT AIM

Edge Localized Modes (ELMs) are disruptive magnetohydrodynamic (MHD) instabilities observed in torus-shaped fusion devices in which an extremely hot plasma is confined magnetically (tokamaks) for the eventual goal of energy production. The project aim is to find ways to control and mitigate ELMs in an early stage of their development..

PROGRESS

New finite-difference methods for extreme anisotropic diffusion were developed. The methods were tested on various discriminating benchmark problems. Results were presented at three international scientific conferences in 2012. In 2013 finite-volume schemes have been developed. In 2014 one journal paper regarding a finite-difference scheme has been published and one regarding the finite-volume scheme has been submitted.

DISSERTATIONS

-

SCIENTIFIC PUBLICATIONS

1. Es, B. van, Koren, B. & Blank, H.J. de (2014). Finite-difference schemes for anisotropic diffusion. *Journal of Computational Physics*, volume 272, pages 526-549.
2. Es, B. van, Koren, B. & Blank, H.J. de (2014). New finite-volume scheme for anisotropic diffusion. *Journal of Computational Physics*, submitted.

CHALLENGES IN SMOOTHED PARTICLE HYDRODYNAMICS

PROJECT AIM

SPH is a gridless, particle based technique and is especially suited for treating problems with free surfaces, multiphase flows, high velocity impacts, crack propagation or large deformations. It has been applied with great success in many fields in engineering and science. However, there are still great challenges ahead, e.g. to achieve reliable and accurate solutions, the computational accuracy, consistency, stability and convergence need further study. Also the treatment of domain boundaries and imposing boundary conditions has triggered attention, but has not been dealt with properly yet.

PROGRESS

Last year we mainly focused on the stability properties of SPH. In literature it can be found that SPH suffers from two types of instabilities. Although the causes are known, finding solutions is not that straightforward. Moreover, there are reasons why one would risk having instabilities. We proposed a concept based on particle collisions that addresses the clustering of particles as a consequence of these instabilities. Furthermore, we developed an accurate expression for the multidimensional Laplacian, analogous to the one-dimensional version we developed in previous years. Finally, we started exploring incompressible SPH. This version of SPH relies on a pressure Poisson equation. In literature, little can be found about the stability and convergence properties of ISPH. We will further explore this field.

DISSERTATIONS

-

SCIENTIFIC PUBLICATIONS

1. Korzilius S.P., Kruisbrink A.C.H., Yue T., Schilders W.H.A., Anthonissen M.J.H. (2014); Momentum conserving methods that reduce particle clustering in SPH. 9th International SPHERIC Workshop, Paris (France), June 2014.

PROJECT LEADERS

WHA Schilders, MJH Anthonissen,
AS Tijsseling

RESEARCH THEME

Mathematical and computational
methods for fluid flow analysis

PARTICIPANTS

SP Korzilius

COOPERATIONS

-

FUNDED

| | |
|--------------|-------|
| TUE | |
| University | 100 % |
| FOM | - |
| STW | - |
| NWO Other | - |
| Industry | - |
| TNO | - |
| GTI | - |
| EU | - |
| Scholarships | - |

START OF THE PROJECT

2012

INFORMATION

SP Korzilius
040 247 3987
s.p.korzilius@tue.nl

EVOLUTION EQUATIONS FOR SYSTEMS GOVERNED BY SOCIAL INTERACTIONS

PROJECT LEADERS

A Muntean, MA Peletier

RESEARCH THEME

Complex dynamics of fluids

PARTICIPANTS

JHM Evers

COOPERATIONS

AAF van de Ven (Eindhoven), SC

Hille (Leiden), PL Curşeu (Tilburg)

RC Fetecau (Burnaby, Canada)

FUNDED

NWO Graduate Programme 2010

University -

FOM -

STW -

NWO Other 100 %

Industry -

TNO -

GTI -

EU -

Scholarships -

START OF THE PROJECT

2011

INFORMATION

A Muntean

040 247 2702

a.muntean@tue.nl

PROJECT AIM

The research aims at studying models in which social interactions occur: e.g. in groups of pedestrians, flocks of birds or schools of fish. Inspiration is taken from measure theory, continuum mechanics and thermodynamics. The research covers a new direction within both the Department of Mathematics and Computer Science, and the Institute for Complex Molecular Systems.

Nevertheless, it fits very well in the philosophy of the ICMS (multi-disciplinarity, complexity). Also, it matches with the new trend towards a more theoretical understanding (in terms of measures) of particle systems and their continuum limits, driven by MA Peletier and his group.

PROGRESS

Together with SC Hille (Leiden) we worked on better mathematical understanding (and analysis) of suitable boundary conditions for measure-valued evolutions. A first publication appeared in the beginning of 2014, communicating the main result of a larger paper currently under review. JHM Evers spent two months in Burnaby, Canada, to work with RC Fetecau. A paper is submitted (co-authored also by L Ryzhik, Stanford, USA) on anisotropy due to a field of vision. Together with PL Curşeu (psychologist, Tilburg) we published a paper on cooperation in groups and the resulting group performance.

DISSERTATIONS

-

SCIENTIFIC PUBLICATIONS

1. P.L. Curşeu, O. Krehel, J.H.M. Evers and A. Muntean. "Cognitive distance, absorptive capacity and group rationality: A simulation study". PLoS ONE, 9(10): e109359 (2014).
2. J.H.M. Evers, S.C. Hille and A. Muntean. "Well-posedness and approximation of a measure-valued mass evolution problem with flux boundary conditions". Comptes Rendus Mathématique, 352: 51-54 (2014).

POROFlow: MATHEMATICAL AND NUMERICAL ANALYSIS OF NON-EQUILIBRIUM EFFECTS IN POROUS MEDIA FLOWS

PROJECT AIM

In this work non-classical mathematical models for flows in porous media are considered. Specifically, the relationships between the quantities of primary interest (like the capillary pressure, or the saturation) are including terms accounting for the non-equilibrium effects. The research will address aspects related to the mathematical modelling, analysis and numerics for such models. In particular, heterogeneous media are being considered, and appropriate coupling conditions between two homogeneous blocks are derived.

PROGRESS

We studied first the uniqueness of weak solutions to non-equilibrium models for flow in porous media. A first result refers to a scalar, pseudo parabolic model. This has been extended to two-phase models, including both dynamic and hysteresis effects. Further, we obtain the existence of weak solutions for the two-phase model allowing degeneracy in the higher order term. Currently, the research is focused on heterogeneous media. Specifically, the conditions at interfaces separating two homogeneous blocks are derived. In particular, we show that trapping is reduced in the dynamic case, when compared to the equilibrium situation.

DISSERTATIONS

-

SCIENTIFIC PUBLICATIONS

1. F.A. Radu, J.M. Nordbotten, I.S. Pop and K. Kumar, A robust linearization scheme for finite volume based discretizations for simulation of two-phase flow in porous media, CASA-Report 14-25 Eindhoven University of Technology, 2014.
2. X. Cao and I.S. Pop, Uniqueness of weak solutions for a pseudo-parabolic equation modeling two phase flow in porous media. Appl. Math. Lett., accepted (CASA Report 14-26, Eindhoven University of Technology, 2014).
3. X. Cao and I.S. Pop, Two-phase porous media flows with dynamic capillary effects and hysteresis: uniqueness of weak solutions. CASA-Report 14-28, Eindhoven University of Technology, 2014.

PROJECT LEADERS

CJ van Duijn

RESEARCH THEME

Mathematical and computational methods for fluid flow analysis

PARTICIPANTS

X Cao, CJ van Duijn, IS Pop, S Nemaadjieu

COOPERATIONS

Prof.dr. H.J.H. Brouwers (Eindhoven)

Prof.dr.ir. S.M. Hassanizadeh (Utrecht)

Dr. P.A. Zegeling (Utrecht)

Prof.dr.ir. R. Helmig (Stuttgart)

Prof.dr. C. Rohde (Stuttgart)

Prof.dr. F.A. Radu (Bergen)

Prof.Dr. J. M. Nordbotten (Bergen)

Dr. K. Kumar (Austin)

Prof.Dr. B. Schweizer (Dortmund)

FUNDED

China Scholarship Council

University -

FOM -

STW -

NWO Other -

Industry -

TNO -

GTI -

EU -

Scholarships 100 %

START OF THE PROJECT

2011

INFORMATION

I Sorin Pop

040 247 5516

i.pop@tue.nl

www.win.tue.nl/~pop



Prof.dr.ir. CJ van Duijn



Prof.dr. JJM Slot

The Eindhoven Applied Analysis group focuses on modeling, analysis of nonlinear differential equations and related computational methods. This diverse expertise is applied to a broad spectrum of problems arising in the engineering sciences, physics and industry. The philosophy is to contribute to the solution of relevant problems in these applied sciences as well as to participate in the development of the underlying mathematical framework. At the moment the main areas of applications are fluid mechanics, rheology, material science (including polymers) and porous media. For example:

POROUS MEDIA

Porous media are (micro-) structures that appear in many disciplines of science and engineering, like ground water hydrology, soil mechanics, petroleum engineering, bioremediation, agricultural science, tissue engineering, or paper production. Typical for such problems is that different phenomena take place on different scales. One of the research topics is upscaling microstructures to macromodels. Examples are problems from hydrology, like groundwater flow, in particular seawater intrusion in coastal waters, contamination of aquifers, or subsurface storage of materials.

AERO ACOUSTICS

One of the many measures taken to reduce the noise of aircraft engines is the application of acoustic lining in the inlet and bypass duct. In order to optimize the damping properties we need to model the sound propagation through the duct. By utilizing the inherent slow variation of a typical flow duct we found an analytic asymptotic solution of the problem that appeared to compare very favorably with proven numerical solutions. This solution was the starting point of a series of similar solutions for related cases, while it has been used to produce a superior matching procedure to connect CFD-type source data to the acoustic field, which is now being used throughout Europe to support CAA implementations.

RHEOLOGY

Rheology is the branch of science focusing on the flow and deformation behavior of complex materials. Complex materials often contain long molecules and/or particles that give them particular flow and deformation behavior in comparison with simple fluids like water or simple solids like pure metals. Examples can be found in industry, the environment, living systems and around the house: paints, polymer processing, production of tires, ink, glues, pharmaceutical -, agricultural - and cosmetic products, in oil production, production of photographic materials, displays and magnetic tapes, food products such as mayonnaise, cheese, margarine, domestic products like toothpaste and liquid detergents, mud, clay, blood and saliva. As in all branches of science also in rheology, in addition to experiment, mathematical modeling and numerical simulation play a very important role. From its inception in the beginning of the last century, when it involved almost exclusively continuum mechanics and constitutive modeling, rheology heavily relies on disciplines belonging to classical applied mathematics, such as differential equations, functional analysis, perturbation theory etc. However, with the increasing focus on the relationship between microscopic structure/processes and macroscopic properties of these complex materials nowadays, probability theory and in particular the theory of stochastic processes has become an essential discipline too. Currently, two focal areas of interest are the constitutive modeling of concentrated solutions of main chain liquid crystalline polymers and that of melts of entangled arbitrarily branched polymers.

PROJECT AIM

This work addresses mathematical and numerical analysis questions related to non-standard porous media flow models, and investigate the effect of different capillary pressure assumptions. In particular, we seek for non-standard entropy solutions to two-phase porous media flow problems, as limit cases when the capillary effects vanish.

PROGRESS

We obtained the existence of weak solutions for the nonlinear and degenerate mathematical equation modelling two-phase flow porous media, involving dynamic effects in the capillary pressure. Furthermore, we introduced an extra unknown: capillary pressure, and transformed the equation into different systems. Then we proved the equivalence of different forms of the model equation. New numerical schemes were introduced and tested with different numerical settings. A-posteriori error estimates are obtained for the complete two-phase flow model, but in the equilibrium/standard case.

DISSERTATIONS

1. Fan, Y. (2012). Dynamic Capillarity in Porous Media - Mathematical Analysis. Eindhoven: Technische Universiteit Eindhoven. (Supervisor: C.J. van Duijn and I.S. Pop).

SCIENTIFIC PUBLICATIONS

-

PROJECT LEADERS

CJ van Duijn

RESEARCH THEME

Mathematical and computational methods for fluid flow analysis

PARTICIPANTS

Y Fan, CJ van Duijn, IS Pop

COOPERATIONS

Dr. C. Cances (Paris), Dr. M. Vohralik (Paris), Dr. C. Choquet (Marseille), Prof. dr.ir. S.M. Hassanizadeh (Utrecht), Prof. dr.ir. R. Helmig (Stuttgart), Prof. dr. C. Rohde (Stuttgart), Prof. dr. A. Mikelic (Lyon), Prof. dr. ir. L.A. Peletier (Leiden)

FUNDED

| | |
|--------------|-------|
| TUE | |
| University | 100 % |
| FOM | - |
| STW | - |
| NWO Other | - |
| Industry | - |
| TNO | - |
| GTI | - |
| EU | - |
| Scholarships | - |

START OF THE PROJECT

2008

INFORMATION

IS Pop

040 247 5516

i.pop@tue.nl

CONSTITUTIVE MODELING OF CONCENTRATED SOLUTIONS OF MAIN-CHAIN LIQUID CRYSTALLINE POLYMERS

PROJECT LEADERS

JJM Slot

RESEARCH THEME

Complex dynamics of fluids

PARTICIPANTS

O Matveichuk

COOPERATIONS

Prof. dr. J. Molenaar (WUR),

Prof. dr. S. Picken (TUD),

Teijin Aramid R&D

FUNDED

Teijin-Aramid BV

University -

FOM -

STW -

NWO Other -

Industry 100 %

TNO -

GTI -

EU -

Scholarships -

START OF THE PROJECT

2008

INFORMATION

JJM Slot

040 247 4381

j.j.m.slot@tue.nl

PROJECT AIM

The primary objective of this project is to develop a molecularly based constitutive model for the rheological behavior of concentrated solutions of main-chain liquid crystalline polymers (LCP) that may show nematic order. The model will be restricted to monodomain (single director) morphologies and the main focus will be on the role that chain flexibility plays in this behavior.

PROGRESS

The code for the simulations of the rod-spring-bead model for the description of concentrated solutions of LCP was developed. The model incorporates hairpins and allows large deviations from highly-ordered state. The model is also capable of treating possible entanglements between polymer chains with hairpins. The code is validated by comparing the results of simulations with the predictions of the earlier developed model for highly-ordered LCP solutions. The results of these simulations were presented at the Annual European Society of Rheology (AERC2012). The results of simulations are in agreement with the available experimental data. The second half of 2012 was primarily devoted to writing the thesis that summarizes the results achieved during the time of this project.

DISSERTATIONS

-

SCIENTIFIC PUBLICATIONS

1. AERC2012 conference proceedings. O. Matveichuk, J.J.M. Slot. Constitutive modeling of highly ordered solutions of main-chain liquid crystalline polymers containing hairpins.

CONSTITUTIVE MODELING OF ARBITRARY BRANCHED POLYMER MELTS

PROJECT AIM

The primary objective of this project is to develop a molecularly based constitutive model for the rheological behavior of polymer melts consisting of arbitrary branched polymer molecules. An industrially relevant and prime example of such a system is provided by a melt of low-density polyethylene (ldPE). As such a system shows such an extreme variation in molecular composition, a description of this composition can only be given in statistical terms. Hence, the idea is to describe such a system by a finite set (ensemble) of representative molecular structures (topologies). Such an ensemble can be obtained via a combination of kinetic modeling and Monte Carlo simulation. This work on kinetic modeling and Monte Carlo simulation is done at the University of Amsterdam in a twin PhD project (not part of the JMBC).

PROGRESS

In 2012 we have focused on the idea of using a statistical representation of ldPE molecules, where the concept of seniority plays the key role. By seniority we mean a segment "depth" from the topological exterior of a molecule. This quantity is simply the number of segments that connects a given segment to the retracting chain end responsible for its relaxation. From our point of view, it is the best measure of topological structures within the ensemble of arbitrary branched polymers. From numerical experiments on theoretical ldPE samples we have observed that segments of seniorities up to 7 compose around 97% of the system mass. Thus, we can reduce the calculation of the linear stress-relaxation response of a complex melt by taking into account only relaxation of such segments. In other words, from every complex branch in a molecule we only explicitly treat the relaxation of a part of it and let the rest be implicitly relax by constraint release. As we want to develop a new computational approach based on the earlier work of Evelyne van Ruymbeke, we have started validation of her model for the ensembles of well described molecules: monodisperse stars, blends of stars, blends of stars and linears, asymmetric stars, symmetric h-polymers, asymmetric h-polymers.

DISSERTATIONS

-

SCIENTIFIC PUBLICATIONS

-

PROJECT LEADERS

JJM Slot

RESEARCH THEME

Complex dynamics of fluids

PARTICIPANTS

V Shchetnikava

COOPERATIONS

Prof. dr. ir. E. van Ruymbeke, UCL, Belgium, Prof. dr. P.D. Iedema, UvA

FUNDED

| | |
|-------------------------------|-------|
| Dutch Polymer Institute (DPI) | |
| University | - |
| FOM | - |
| STW | - |
| NWO Other | 100 % |
| Industry | - |
| TNO | - |
| GTI | - |
| EU | - |
| Scholarships | - |

START OF THE PROJECT

2009

INFORMATION

JJM Slot
040 247 4381
j.j.m.slot@tue.nl

PROJECT LEADERS

P Notten, MA Peletier, IS Pop

RESEARCH THEME

Complex dynamics of fluids

PARTICIPANTS

K Kumar, TL van Noorden, P Notten,
MA Peletier, IS Pop

COOPERATIONS

Prof. R. Helmig (Stuttgart)
Prof. W. Jäger (Heidelberg)
Prof. A. Mikelić (Lyon)
Prof. F.A. Radu (Bergen)
Dr. M. Neuss-Radu (Erlangen)

FUNDED

| | |
|--------------|-------|
| STW | |
| University | - |
| FOM | - |
| STW | 100 % |
| NWO Other | - |
| Industry | - |
| TNO | - |
| GTI | - |
| EU | - |
| Scholarships | - |

START OF THE PROJECT

2008

INFORMATION

K Kumar
kkumar@ices.utexas.edu

S Pop
040 247 5516
i.pop@tue.nl

PROJECT AIM

The project is related to the development of all-solid state rechargeable batteries having a high storage capacity. Such devices have a complex 3D geometry for the electrodes to enhance the surface area. The challenges are in the development of the appropriate technologies for the formation of these electrodes. In particular we focus on chemical vapor deposition processes (CVD), with the aim of getting a deeper understanding of the reactions taking place in a complex geometry.

PROGRESS

Depending on the size of the reaction domain, the changes in the pore structure that are due to the deposition process may or may not be neglected. In mathematical terms, the models are defined in a fixed, respectively variable geometry, when the deposition layer generates a free boundary at the pore scale. We have developed mathematical models for both situations and carried out numerical simulations for both the fixed geometry and variable geometry showing a good agreement with the experimental results obtained for the deposition of Titanium dioxide inside trenches of different diameters. This work has implied determining the physical and chemical parameters. For the multi-scale computations, numerical methods inspired from domain decomposition ideas have been proposed and the convergence of the scheme has been proved. Computing the full solution in a domain with oscillating boundary requires a lot of computational effort, as one has to achieve an accuracy that agrees with the scale of oscillations. To approximate these solutions, one defines equations in a simpler domain, where flat boundaries but modified boundary conditions approximate the rough one. The two situations mentioned before were considered: the fixed geometry case, and the time dependent geometry at the microscale (free boundaries). We have derived an approximating (effective) model where a flat boundary is replacing the oscillatory boundary, but defining an effective boundary condition. In the fixed geometry case, we provide rigorous mathematical proofs for the upscaling procedure. The second case, when we take into account the geometry changes at the microscale, is more involved, and we use formal asymptotic methods to derive these boundary conditions. Further, to understand the flow in a domain with variable geometry, we have considered a thin strip with reactions taking place at the lateral boundaries of the strip under dominant transport conditions. We have derived upscaled equations for the solute concentration, which are similar to the Taylor dispersion and we have performed numerical simulations to compare the upscaled equations with other simpler upscaled equations. We have further studied the rigorous homogenization process for the reactive flows for a periodic array of cells and proved the validity of upscaled equations. These reactive flows model the crystal precipitation and dissolution processes in a porous medium. Our results are in agreement with the macroscale equations proposed in the literature. In addition, numerical methods, for instance, mixed finite element method, to compute the solution have been proposed and the proofs for the convergence of these schemes have been obtained..

DISSERTATIONS

1. Upscaling of Reactive Flows, Sep 2012, CASA, TU Eindhoven.

SCIENTIFIC PUBLICATIONS

-



Prof.dr.ir. JAM Kuipers



Prof.dr.ir. M van Sint Annaland

The research group SMR participates amongst others in the OSPT and the JMBC for fluid mechanics and focuses on fundamentals of the discipline of chemical reaction engineering. Our main area of interest is the quantitative description of transport phenomena (including fluid flow) and the interplay with chemical transformations in multiphase chemical reactors. The generation of new knowledge and the development of new reactor models with improved predictive capability for this industrially important class of chemical reactors constitutes an important goal of our research activities. Through the intended co-operation with other (application oriented) research groups, both fundamental aspects and those closely related to applications will be studied through concerted action. The main research topics of the new group SMR can be divided into the following three areas: Multiphase Reactors, Advanced Experimental Techniques and Novel Reactors, which will be discussed below in more detail.

An important area of attention is the development of advanced reactor models for multiphase reactors with industrial relevance. At present our research focuses on the hydrodynamics in these reactors because it is generally recognized that the lack of understanding of the flow phenomena is one of the central difficulties in the design and scale-up of multiphase reactors. In the near future the interplay of flow phenomena with chemical reactions will be studied in great detail. We use various types of CFD models (both commercial codes but mostly "in house" made codes) to study the relevant hydrodynamic phenomena at all relevant length and time scales (i.e. at the microscopic, mesoscopic and macroscopic scale). In our group both multifluid models are being developed and models which treat the dispersed phase (particles, bubbles or droplets) in a discrete manner accounting for possible encounters between the dispersed elements.

The second important area of our research deals with the development of advanced experimental techniques to measure key quantities (i.e. local volume fractions and velocities of the dispersed and continuous phase). As an example we can mention the development of the digital particle image velocimetry technique to measure in a non-intrusive manner the velocity map of both the liquid phase and dispersed gas bubbles in (dense) gas-liquid dispersions. This type of flow very often arises in a variety of gas-liquid contactors/reactors. In this area we co-operate with specialists within the J.M. Burgerscentrum for fluid mechanics. Of course this research activity is intimately connected to the first research topic. Our third important area of research deals with the development of novel (multiphase) reactors with emphasis on integration and intensification of relevant process steps. As an example we can mention here the Rapid Reaction Cycling Reverse Flow (RRCRF) which integrates (in a thermal sense) endothermic and exothermic heterogeneously catalyzed chemical reactions where the endothermic reaction causes rapid (reversible) catalyst deactivation. These types of chemical reaction systems often arise in practice for instance in the production of lower alkenes from the corresponding alkanes via heterogeneously catalyzed dehydrogenation. The knowledge and tools developed within the other two areas of attention provide a sound basis to place this research activity on a firm footing.

MODIFICATION OF KINETIC THEORY FOR GRANULAR FLOW BY INCLUDING FRICTION

PROJECT AIM

The aim of this project is to modify the current KTGF by including rotational velocity and particle-particle friction. This can give more insight into the hydrodynamics of granular flows in industrial size reactors. Then we incorporate the effect of friction between the particles in our current in-house two-fluid model code, and at a later stage in the multi-fluid model. Validation of the modified KTGF model will follow from a comparison with the DPM model, in which friction can be modeled with reasonable accuracy, and also by comparing with one-to-one experiments.

PROGRESS

Currently, the derivation of KTGF in which rotational velocity and friction are included is finished. The closure equations for viscosity, thermal conductivities have been derived and the new model has been implemented in our in-house TFM code. Validation of the new model will be carried out by discrete particle modelling and one-to-one experiment later on.

DISSERTATIONS

-

SCIENTIFIC PUBLICATIONS

-

PROJECT LEADERS

JAM Kuipers

RESEARCH THEME

Mathematical and computational methods for fluid flow analysis

PARTICIPANTS

L Yang, JT Padding

COOPERATIONS

-

FUNDED

| | |
|--------------|-------|
| ERC Grant | |
| University | - |
| FOM | - |
| STW | - |
| NWO Other | - |
| Industry | - |
| TNO | - |
| GTI | - |
| EU | 100 % |
| Scholarships | - |

START OF THE PROJECT

2013

INFORMATION

L Yang
040 247 8023
l.yang@tue.nl

PROJECT LEADERS

NG Deen, JAM Kuipers, M van Sint Annaland

RESEARCH THEME

Mathematical and computational methods for fluid flow analysis

PARTICIPANTS

M Banaei, Z Li

COOPERATIONS

-

FUNDED

DPI (Dutch Polymer Institute)

University -

FOM -

STW -

NWO Other 100 %

Industry -

TNO -

GTI -

EU -

Scholarships -

START OF THE PROJECT

2012

INFORMATION

M Banaei

040 247 8026

m.banaei@tue.nl

PROJECT AIM

1. Extension of numerical models for prediction of hydrodynamics and heat transfer in polymerization reactors.
2. Developing the PIV/DIA measurements for pressurized gas fluidized beds and quantitative investigation of the heat effects of liquid injection.

PROGRESS

1. Designing an endoscope for capturing hydrodynamics of pressurized fluidized beds
2. Implementation and verification of energy equations into the existent two-fluid model
3. Error analysis on the reconstruction techniques for electrical capacitance tomography.

DISSERTATIONS

-

SCIENTIFIC PUBLICATIONS

-

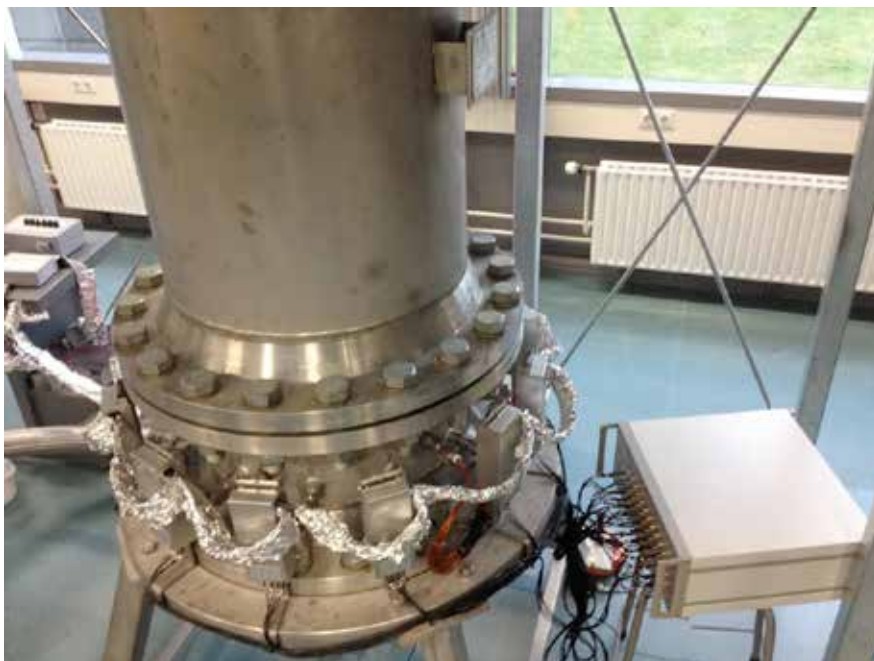

BUBBLES ON CUTTING EDGE

PROJECT AIM

The projects aims to prepare a computational model based on an Euler-Lagrange approach to simulate a bubble column with a wire-mesh inside it. The effect of the wires will be to cut bubbles into smaller pieces and thereby enhance the mass transfer in the column. The liquid phase flow patterns may shift towards plug flow kind of behavior leading to reduced back-mixing. The presence of catalyst coated wires can also be modeled by specifying reaction zone along wires.

PROGRESS

Liquid hydrodynamics has been modeled and verified first without presence of bubbles. After that bubbles were introduced. Bubble cutting through wires was achieved by a self-developed bubble cutting algorithm. Test cases to verify the algorithm were successful. Thereafter the effect of various parameters such as mesh pitch, gas superficial velocity etc., were studied. A new hybrid VOF-DBM model taking into account the free surface in the column has also been included. Effect of mass transfer with multiple wire mesh in the column is studied to find effect of multiples meshes on mass transfer and optimal distance between meshes.

DISSERTATIONS

1. Cutting Bubbles: Discrete bubble modeling of a Micro-structured bubble column
3rd Mar 2015.

SCIENTIFIC PUBLICATIONS

1. Jain, D., Kuipers, J.A.M. and Deen, N.G. (2014). Numerical study of coalescence and breakup in a bubble column using a hybrid volume of fluid and discrete bubble model approach. *Chemical Engineering Science*, 119, 134-146.

PROJECTLEADERS

NG Deen

RESEARCHTHEME

Mathematical and computational methods for fluid flow analysis

PARTICIPANTS

D Jain, JAM Kuipers

COOPERATIONS

-

FUNDED

| | |
|---------------------------|-------|
| European Research Council | |
| University | - |
| FOM | - |
| STW | - |
| NWO Other | - |
| Industry | |
| TNO | - |
| GTI | - |
| EU | 100 % |
| Scholarships | - |

START OF THE PROJECT

2011

INFORMATION

NG Deen

040 247 3681

N.G.Deen@TUE.nl

www.tue.nl/staff/N.G.Deen

PROJECTLEADERS

JAM Kuipers

RESEARCHTHEME

Mathematical and computational methods for fluid flow analysis

PARTICIPANTS

Y Xu, JT Padding, MA van der Hoef

COOPERATIONS

-

FUNDED

FOM

University -

FOM 100 %

STW -

NWO Other -

Industry -

TNO -

GTI -

EU -

Scholarships -

START OF THE PROJECT

2011

INFORMATION

JAM Kuipers

040 247 4158

J.A.M.Kuipers@tue.nl

www.chem.tue.nl/smr

PROJECT AIM

The aim of the current work is to investigate the intruder behavior in a prefluidized granular bed, both from simulations and experiments, to obtain the force law and compare with literature results and to fully understand the viscosity of the idealized system obtained by different methods.

PROGRESS

The impact of a large sphere dropping into a prefluidized granular bed was numerically studied using a state-of-the-art hybrid Discrete Particle and Immersed Boundary Method (DP-IBM). The simulation results match well with existing experimental observations. This work revealed the importance of the interstitial gas and it also shows that the current simulation scheme could become a powerful tool to investigate the effect of interstitial gas on the dynamics of projectile impact cratering. An intruder moving with constant velocity through a prefluidized granular bed was also investigated and results show good agreement with the existing experimental work. For the model system which was designed to check the validity of Stokes' law and also the viscosity in an idealized granular fluid with well-controlled density and granular temperature, the dropping ball method, the Couette flow method and also Green-Kubo method were employed.

DISSERTATIONS

-

SCIENTIFIC PUBLICATIONS

1. Xu, Y., Padding, J.T., & Kuipers, J.A.M. Numerical investigation of the vertical plunging force of a spherical intruder into a prefluidized granular bed. *Physical Review E*, 90(6), 062203.
2. Xu, Y., Padding, J.T., Hoef, M.A. van der, Kuipers, J.A.M. Numerical investigation of the vertical plunging force of a spherical intruder into a granular bed. 10th International Conference on Computational Fluid Dynamics In the Oil & Gas, Metallurgical and Process Industries, 17-19 June 2014, SINTEF, Trondheim, Norway.

PROJECT AIM

In the ECN MILENA process biomass is gasified by an indirect route comprising of a system of two interconnected fluidized bed reactors. The improvement in the performance of the process with chemical looping is investigated in detail, focusing on the heat and oxygen transport in the system, and the effect of the residence time of gas and particles. A high-temperature endoscopic PIV/DIA technique has been developed to investigate the bed hydrodynamics under high temperature fluidization conditions and to quantify the rate of heat and oxygen transport. An extended phenomenological model is developed and used for process optimization and scale up effects.

PROGRESS

The novel endoscopic PIV/DIA has been validated and it has been demonstrated that the technique is capable to measure accurately the bubble size distribution and solids mass flux profiles at elevated temperatures. The results have shown that the literature correlations for the minimum fluidization conditions at elevated temperatures and different gas mixtures are inadequate and a new correlation for the bed porosity at incipient fluidization conditions have been developed. In addition, a model for the indirect gasification of biomass has been developed in Aspen Plus and subsequently extended to include oxygen carriers. More detailed kinetics for the tar conversion in the presence of oxygen carriers was found essential is currently being determined using TGA analysis.

DISSERTATIONS

-

SCIENTIFIC PUBLICATIONS

1. 3rd International Conference on Chemical Looping. Oral presentation “Modelling od Chemical Looping for Biomass Gasification”, September 9th – 11th 2014, Chalmers University of Technology in Gothenburg, Sweden.

PROJECTLEADERS

F Gallucci, M van Sint Annaland

RESEARCHTHEME

Complex dynamics of fluids

PARTICIPANTS

I Campos Velarde

COOPERATIONS

-

FUNDED

| | |
|--------------|-------|
| ADEM | |
| University | - |
| FOM | - |
| STW | - |
| NWO Other | 100 % |
| Industry | - |
| TNO | - |
| GTI | - |
| EU | - |
| Scholarships | - |

START OF THE PROJECT

2011

INFORMATION

I Campos Velarde
040 247 3685
i.camposvelarde@tue.nl

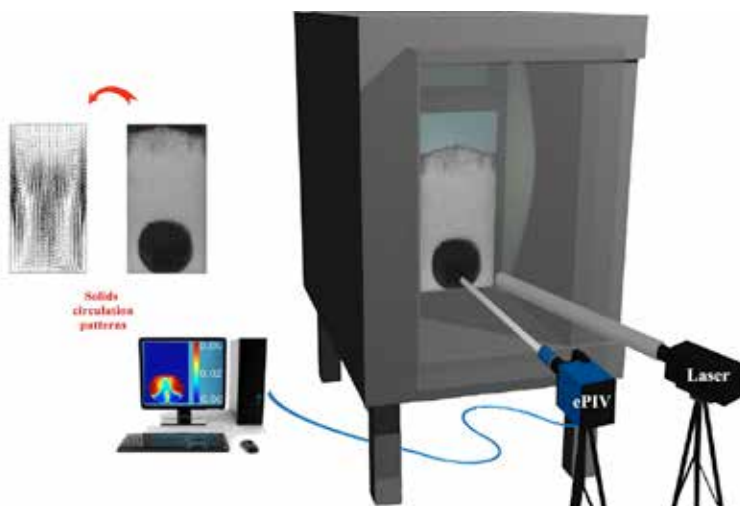

PROJECT LEADERS

I Roghair, F Gallucci, M van Sint Annaland

RESEARCH THEME

Complex dynamics of fluids

PARTICIPANTS

Maria Angel San Pio Bordeje

COOPERATIONS

-

FUNDED

NWO

University -

FOM -

STW -

NWO Other 100 %

Industry -

TNO -

GTI -

EU -

Scholarships -

START OF THE PROJECT

2013

INFORMATION

MA San Pio Bordeje

040 247 8184

m.a.san.pio.bordeje@tue.nl

PROJECT AIM

The project objectives includes:

- b) Detailed characterization of oxygen carriers and development of improved particle models that link redox kinetics/mass transfer processes to morphological and structural changes during the reduction and oxidation cycles;
- c) Extension of the particle models with thermodynamics and their verification and validation;
- d) Experimental investigation in packed bed CLC setups (testing different oxygen carriers) and comparison with simulations where the new particle models have been embedded in available reactor models for packed bed CLC.

PROGRESS

An extensive experimental study of Cu-based oxygen carriers has been carried out including Thermo Gravimetric Analysis (TGA), BET (surface area, porosity, pore size distribution), SEM-EDX and XRD. The importance of oxygen uncoupling during the redox reactions has been identified which may explain the dramatic drop in the reaction rate in the redox kinetics after approximately 80% conversion in several different oxygen carriers. A new model based on the Shrinking Core Model (SCM) but extended with oxygen uncoupling kinetics is developed.

DISSERTATIONS

-

SCIENTIFIC PUBLICATIONS

1. Poster contribution in 3rd International Chemical Looping Combustion conference in Chalmers, Sweden (September 2014).
2. Poster contribution in NPS conference in Utrecht, The Netherlands (November 2014).
3. Oral Presentation in the workshop Modification in Porous Media in Bad Soden, Germany (November 2014).

CUTTING BUBBLES. THE COALESCENCE AND BREAK-UP OF BUBBLES ON MICRO SCALE

PROJECT AIM

Bubbles, that rise in a bubble column, have the tendency to coalesce. This reduces the interfacial area with respect to the volume of the gas. To reduce the loss of interfacial area, a wired mesh is introduced in the column. This mesh will introduce the break-up of bubbles.

In this research, the effect of the coalescence and break-up of the model due to the wired mesh is studied using Direct Numerical Simulations. The results of the simulations will be validated using clean experiments. The experiments will be performed in well defined environments for increasingly complex wire configurations.

PROGRESS

In the last year, a novel second order implicit Immersed Boundary method was implemented and verified. The new combined Volume of Fluid and Immersed Boundary method was used to study the break-up of bubbles due to the interaction with a single wire. The results are being compared with experiments and will be published soon.

DISSERTATIONS

-

SCIENTIFIC PUBLICATIONS

1. Baltussen, M.W., Kuipers, J.A.M. and Deen, N.G., A critical comparison of surface tension models for the volume of fluid method, Chemical Engineering Science, 109 (2014), 65-74.

PROJECT LEADERS

NG Deen, JAM Kuipers

RESEARCH THEME

Mathematical and computational methods for fluid flow analysis

PARTICIPANTS

MW Baltussen

COOPERATIONS

-

FUNDED

European Research Council

University -

FOM -

STW -

NWO Other -

Industry -

TNO -

GTI -

EU 100 %

Scholarships -

START OF THE PROJECT

2011

INFORMATION

JAM Kuipers

040 247 4158

J.A.M.Kuipers@TUE.nl

www.chem.tue.nl/smr

NOVEL DISCRETE ELEMENT MODEL FOR ARBITRARY SHAPED NON-SPHERICAL PARTICLES

PROJECT LEADERS

JAM Kuipers

RESEARCH THEME

Mathematical and computational
methods for fluid flow analysis

PARTICIPANTS

LJH Seelen, JT Padding

COOPERATIONS

-

FUNDED

ERC

University -

FOM -

STW -

NWO Other -

Industry -

TNO -

GTI -

EU 100 %

Scholarships -

START OF THE PROJECT

2012

INFORMATION

LJH Seelen

040 247 5707

L.J.H.Seelen@tue.nl

www.tue.nl

PROJECT AIM

The main goal of this study is to develop a new discrete element method (DEM) that can describe granular materials that have an arbitrary shape. The method will be used to describe granular flows in rotating drums and hoppers.

PROGRESS

In the last year a collision detection model for convex non-spherical particles has been developed. A broad-phase collision detection strategy has also been implemented and an improved quaternion based integration scheme is developed. Currently the results for this new integration scheme are written down for publication.

DISSERTATIONS

-

SCIENTIFIC PUBLICATIONS

-

HEAT TRANSFER MODELING IN GAS-SOLID FLUIDIZED BEDS

PROJECT AIM

This project aims at modeling heat transfer in gas-solid fluidized beds using the CFD-DEM method. This CFD-DEM method was extended with heat transfer. A new measuring technique using visual and infrared camera was developed called the DIA/PIV/IR technique. Comparison of CFD-DEM with this technique was done. Moreover, CFD-DEM was used to validate with theoretical models like the Davidson and Harrison bubble model for bubble to emulsion heat transfer. This study was done for pseudo 2D and 3D bed geometry.

PROGRESS

A combined infrared/particle image velocimetry/digital image analysis (IR/PIV/DIA) measuring technique for investigating heat transfer in gas-solid fluidized bed has been recently developed. This new technique gives insightful information and quantitative data on particle volume fractions, particle volume fluxes and temperature distributions in fluidized beds for CFD validations. Further work comparing simultaneous thermal and hydrodynamic data of a pseudo 2-D fluidized bed obtained using this new technique with results from CFD-DEM simulations has been done. An extensive series of time-averaged volume fractions, volume fluxes and temperature distributions as well as instantaneous profiles are presented. This detailed comparison between the experimental and simulated profiles shows the capabilities of state-of-the-art CFD-DEM simulations, and pinpoints where simulation (and also measurement) techniques still can be improved.

DISSERTATIONS

-

SCIENTIFIC PUBLICATIONS

-

PROJECT LEADERS

JAM Kuipers

RESEARCH THEME

Complex structures of fluids

PARTICIPANTS

A Patil, EAJF Peters

COOPERATIONS

-

FUNDED

| | |
|--------------|-------|
| NWO | |
| University | - |
| FOM | - |
| STW | - |
| NWO Other | 100 % |
| Industry | - |
| TNO | - |
| GTI | - |
| EU | - |
| Scholarships | - |

START OF THE PROJECT

2014

INFORMATION

JAM Kuipers
040 247 4158
J.A.M.Kuipers@TUE.nl
www.chem.tue.nl/smr

HYDRODYNAMICS OF FLUIDIZED NON-SPHERICAL PARTICLES: DIRECT NUMERICAL SIMULATIONS

PROJECT LEADERS

JT Padding

RESEARCH THEME

Complex dynamics of fluids

PARTICIPANTS

SKPacha Sanjeevi, JAM Kuipers

COOPERATIONS

-

FUNDED

ERC

University -

FOM -

STW -

NWO Other -

Industry -

TNO -

GTI -

EU 100 %

Scholarships -

START OF THE PROJECT

2014

INFORMATION

SK Pacha Sanjeevi

040 247 8785

www.tue.nl

PROJECT AIM

In this research, we aim to find correlations for the hydrodynamic forces and torques acting on dense collections of non-spherical particles using direct numerical simulations. This is of crucial importance for coarse-grained simulations of fluidized bed reactors for the production of biofuels and bio-chemicals from dried and milled biomass.

PROGRESS

The project involves a large set of direct numerical simulations on random configurations of non-spherical particles, requiring a significant amount of computational resources. Therefore as a initial step, a compute time application at the national supercomputing center – SARA, Amsterdam, has been submitted and have been awarded already with the requested compute time. The simulation code has been already compiled at SARA and in the coming future, large batch of simulations on many cores would be performed and results would be published.

DISSERTATIONS

-

SCIENTIFIC PUBLICATIONS

-

BUBBLES ON THE CUTTING EDGE: EXPERIMENTAL INVESTIGATION ON MICRO-STRUCTURED BUBBLE COLUMNS

PROJECT AIM

The aim of the project is to construct a laboratory scale micro-structured bubble column reactor with a wire mesh to demonstrate proof of principle. The impact of wire mesh on bubble cutting, hydrodynamics characteristics will be studied in-depth experimentally using advanced measurement techniques such as Laser Doppler Anemometry and X-ray tomography. X-ray tomography experiments will be done in co-operation with HZDR, Dresden, Germany. The reaction enhanced mass transfer will also be studied for the case of CO₂ in NaOH to determine interfacial area and mass transfer coefficient.

PROGRESS

Experiments with chemical reaction have been done to study the effect of wire mesh on chemical reaction. It was observed that the presence of wire mesh does enhance the speed of reaction. Experiments are done with dodecane-nitrogen system and are compared with air-water to study the effect of liquid properties on bubble cutting behavior for several wire mesh lay-outs. The effect of increasing the number of meshes in the bubble column was also investigated for experiments with chemical reaction and dodecane.

DISSERTATIONS

-

SCIENTIFIC PUBLICATIONS

1. K. Thiruvalluvan Sujatha, B.G.J. Meeusen, N. G. Deen, and J. A. M. Kuipers. "Experimental Studies of Bubbly Flow in a Pseudo-2D Micro-Structured Bubble Column Reactor Using Digital Image Analysis." Chemical Engineering Science (2014).

PROJECT LEADERS

NG Deen

RESEARCH THEME

Mathematical and computational methods for fluid flow analysis

PARTICIPANTS

K Thiruvalluvan Sujatha,
JAM Kuipers

COOPERATIONS

HZDR, Dresden, Germany

FUNDED

European Research Council
University -
FOM -
STW -
NWO Other -
Industry -
TNO -
GTI -
EU 100 %
Scholarships -

START OF THE PROJECT

2012

INFORMATION

NG Deen
040 247 3681
040 247 4931
N.G.Deen@TUE.nl
www.tue.nl/staff/N.G.Deen

PROJECT LEADERS

NG Deen, JAM Kuipers, M van Sint Annaland

RESEARCH THEME

Mathematical and computational methods for fluid flow analysis

PARTICIPANTS

Z Li, M Banaei

COOPERATIONS

DPI

FUNDED

Dutch Polymer Institute (DPI)

University -

FOM -

STW -

NWO Other -

Industry 100 %

TNO -

GTI -

EU -

Scholarships -

START OF THE PROJECT

2012

INFORMATION

Z. Li

040 247 8027

z.z.li@tue.nl

www.tue.nl/en/employee/ep/e/d/

ep-uid/20121533/

PROJECT AIM

To extend the discrete particle model and multi-fluid model with heat and mass balances to obtain an accurate description of polymerization processes on a lab-scale system and bench scale system under actual process conditions, i.e. involving reaction, significant heat production and high pressures.

PROGRESS

DPM (discrete particle model) simulations were performed for a fluidized bed with particles containing a constant heat source, mimicking the heat production in actual polymerization processes. The effect of superficial velocity and operating pressure on the particle temperature distribution in the fluidized bed with heat production have been summarized in two papers, which will be submitted shortly. Later on, the particle size distribution (PSD) has been taken into consideration to investigate the cause of hot spots in gas-phase polyolefin reactors. It is found that fine particles with high heat production are located above the free-board and at the side walls. These can be overheated and lead to the formation of hot spots.

DISSERTATIONS

-

SCIENTIFIC PUBLICATIONS

-

POLYDISPERSED GRANULAR FLOWS THROUGH INCLINED CHANNELS

PROJECT AIM

The aims of the project are,

- To study the flow behavior of polydisperse granular particles on non-rotating and rotating inclined chutes
- Prediction of influences of polydispersity of the particles on flow characteristics
- To compare discrete element model (DEM) simulation results with experimental measurement.

PROGRESS

- We have cross-validated the PIV, PTV, Sensor and DEM technique for granular flows down inclined rotating chutes.
- We have investigated the influence of base roughness, in combination with chute rotation, on monodisperse and bidisperse (in density) granular flows through semi-cylindrical chutes.
- We have investigated the influence of different process parameters on various quantities which are determining the rate of segregation and radial burden distribution in a binary (density) mixture of granular particles flowing down a rotating chute.

DISSERTATIONS

-

SCIENTIFIC PUBLICATIONS

1. Shirsath, S.S., Padding, J.T., T.W.J. Peeters, Clercx, H.J.H. & Kuipers, J.A.M. (2014). Numerical investigation of monodisperse granular flow through an inclined rotating chute. *AICHE, Journal*, 60(10), 3424-3441.
2. Shirsath, S.S., Padding, J.T., Clercx, H.J.H. & Kuipers, J.A.M. (2014) Cross-validation of 3D Particle Tracking Velocimetry with other technique for granular flows down rotating chutes. Submitted to *CES Journal*.
3. Shirsath, S.S., Padding, J.T., Clercx, H.J.H. & Kuipers, J.A.M. Simulation study of the effect of wall roughness on the dynamics of granular flows in rotating semi-cylindrical chutes. Submitted to *AICHE Journal*.

PROJECTLEADERS

JAM Kuipers, JT Padding, HJH Clercx

RESEARCHTHEME

Mathematical and computational methods for fluid flow analysis

PARTICIPANTS

SS Shirsath

COOPERATIONS

-

FUNDED

| | |
|-----------------|-------|
| STW, Tata Steel | |
| University | - |
| FOM | - |
| STW | 100 % |
| NWO Other | - |
| Industry | - |
| TNO | - |
| GTI | - |
| EU | - |
| Scholarships | - |

START OF THE PROJECT

2010

INFORMATION

JAM Kuipers
040 247 4158
J.A.M.Kuipers@TUE.nl
www.chem.tue.nl/smr

INTEGRATED AND STRUCTURED FLUID CATALYTIC CRACKING REACTOR

PROJECT LEADERS

NG Deen, JAM Kuipers, PCA
Bruijninckx, BM Weckhuysen

RESEARCH THEME

Mathematical and computational
methods for fluid flow analysis

PARTICIPANTS

L Mu

COOPERATIONS

-

FUNDED

MCEC
NWO
University -
FOM -
STW -
NWO Other 100 %
Industry -
TNO -
GTI -
EU -
Scholarships -

START OF THE PROJECT

2014

INFORMATION

L Mu
040 247 8794
l.mu@tue.nl
www.chem.tue.nl/smr

PROJECT AIM

The aim of this work is to find out how heterogeneities affect the reactor performance. This includes heterogeneities in particle flow structures, particle size and liquid distribution. A full flex CFD-DEM model employing state-of-the-art tools (LIGGGHTS/CFDEM/OpenFOAM) will be developed. Study the influence of each of the elements mentioned above systematically and validate the model experimentally for a cold-flow lab-scale setup.

PROGRESS

We reviewed former mathematical models which are used in CFD-DEM simulation of gas-solid reacting flows in fluid catalytic cracking process. We started simulating a jet in fluidized bed with CFDEM coupling software.

DISSERTATIONS

-

SCIENTIFIC PUBLICATIONS

-

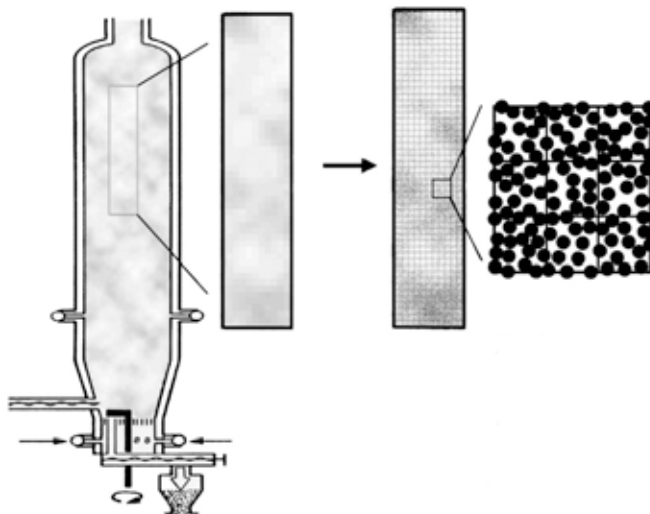

NEW DRIVING FORCES FOR DRY FRACTIONATION

PROJECT AIM

The project aim is to combine separation methods to enhance the separation (of crude food materials) in terms of energy efficiency. Therefore, it is important that there is no water needed as dehydration of the product is energy intensive. The main focus of the project will lie on the use of tribo-electrification as the base for the separation method. Our partners at WUR will experimentally investigate the tribo-electric charging of pneumatically conveyed powder, while we will do that via a numerical route using CFD-DEM. The combined insights will be used to develop a separator.

PROGRESS

In the past year a novel method has been developed to determine particles velocities in a narrow duct; a hybrid PTV/PIV. The velocities (and positions) were successfully in a duct of 2 millimeter wide while particles of 400 micrometer traveled up to 10 m/s. These results are submitted for publication and will be used to validate our model.

DISSERTATIONS

-

SCIENTIFIC PUBLICATIONS

1. Korevaar, M. W., Padding, J. T., Van der Hoef, M. A., & Kuipers, J. A. M. Integrated DEM-CFD modeling of the contact charging of pneumatically conveyed powders. *Powder Technology* (2014), 258, 144–156. doi:<http://dx.doi.org/10.1016/j.powtec.2014.03.020>.

PROJECTLEADERS

JT Padding, JAM Kuipers

RESEARCHTHEME

Complex structures of fluids

PARTICIPANTS

MW Korevaar

COOPERATIONS

Maarten Schutyser (WUR), Jue Wang (WUR), Martin de Wit (WUR) Tatsushi Matsuyama (Soka University)

FUNDED

| | |
|--------------|-------|
| STW | |
| University | - |
| FOM | - |
| STW | 100 % |
| NWO Other | - |
| Industry | - |
| TNO | - |
| GTI | - |
| EU | - |
| Scholarships | - |

START OF THE PROJECT

2011

INFORMATION

JAM Kuipers
040 247 4158
J.A.M.Kuipers@TUE.nl
www.chem.tue.nl/smr

CLINGCO2: CHEMICAL LOOPING REFORMING FOR PURE HYDROGEN PRODUCTION WITH INTEGRATED CO₂ CAPTURE

PROJECT LEADERS

F Gallucci, I Roghair, M van Sint Annaland

RESEARCH THEME

Complex dynamics of fluids

PARTICIPANTS

JA Medrano Jiménez, R Voncken, V Spallina

COOPERATIONS

-

FUNDED

STW

University -

FOM -

STW 100 %

NWO Other -

Industry -

TNO -

GTI -

EU -

Scholarships -

START OF THE PROJECT

2013

INFORMATION

JA Medrano Jiménez

040 247 8055

j.a.medrano.jimenez@tue.nl

PROJECT AIM

A novel chemical looping membrane reactor concept for ultra-pure hydrogen production with integrated CO₂ capture is investigated in this project. The technology is based on steam methane reforming in a fluidized bed reactor with immersed Pd-membranes using oxygen carrier particles to supply the required energy and oxygen for the reactions. The study includes detailed experimentation on the hydrodynamics of the reactor using PIV/DIA, oxygen carrier kinetics, detailed CFD-based modelling as well as phenomenological models for scale-up and optimization and an experimental demonstration with a techno-economic analysis.

PROGRESS

An extensive techno-economic analysis of a full process plant for H₂ production with integrated CO₂ capture based on different reactor concepts has been carried out. Results have indicated that our proposed reactor concept is an attractive solution over more traditional processes. A thorough characterization of the solids acting as oxygen carrier for the project has been done. Moreover, different Pd-Ag membranes have been tested under reactive conditions, also in combination with the studied oxygen carrier. Hydrodynamics of the systems have also been studied in detail and mass transfer limitations from the bed to the surface of the membrane have been assessed.

DISSERTATIONS

-

SCIENTIFIC PUBLICATIONS

1. Medrano Jimenez, J.A., Spallina, V., Sint Annaland, M. van & Gallucci, F. (2014). Thermodynamic analysis of a membrane-assisted chemical looping reforming reactor concept for combined H₂ production and CO₂ capture. *International Journal of Hydrogen Energy*, 39, 4725-4738.
2. Medrano Jimenez, J.A., Voncken R.J.W., Roghair I., Sint Annaland, M. van & Gallucci, F. (2014). Experimental and numerical study on gas pockets surrounding horizontally immersed membranes in fluidized beds. Oral: Proceedings of the XXI International Conference on Chemical Reactors, CHEMREACTOR-21, 22-25 September 2014, Delft, The Netherlands.
3. Medrano Jimenez, J.A., Hamers H.P., Ortiz M., Ramirez A., V., Sint Annaland, M. van., Williams G. & Gallucci, F. (2014) NiO/CaAl₂O₄ catalyst as a very active oxygen carrier for low temperature chemical looping applications. Oral: Proceedings of the 3rd International Conference on Chemical Looping, 9-11 September 2014, Gothenburg, Sweden.
4. Medrano Jimenez, J.A., Spallina, V., Sint Annaland, M. van & Gallucci, F. (2014) Oral: The Membrane-Assisted Chemical Looping Reforming concept as efficient reactor for H₂ production and CO₂ capture: a comparison to benchmark technology. Proceedings of the 14th NPS, 3-5 November 2014, Utrecht, The Netherlands.
5. Spallina, V., Sint Annaland, M. van & Gallucci, F. (2014). Comparison of advanced processes based on chemical looping and membrane separation fully integrated in an H₂ production plant with CO₂ capture. Oral: Proceedings of the XXI International Conference on Chemical Reactors, CHEMREACTOR-21, 22-25 September 2014, Delft, The Netherlands, (pp. 1-20).
6. Medrano Jimenez, J.A., Spallina, V., Sint Annaland, M. van & Gallucci, F. (2014). Chemical looping membrane reformer concept for H₂ production and CO₂ capture. Oral : 22nd PIN meeting Process Intensification Network(PIN), 21 May 2014, New Castle, England., (pp. 1-35). Newcastle.

SIMULATION OF PROPPANT TRANSPORT FOR SHALE GAS PRODUCTION

PROJECT AIM

In shale formations the gas-permeability is increased by injecting complex particle-filled liquids (fracking). The so-called proppant particles prevent the fractures from fully closing when the flow of liquid is stopped. In order to predict where the particles deposit in a network of fractures we need to know how proppant is transported in a network of fractures. This research is aimed at modelling the particle transport on the relevant length scales. Three scales of coarse-grained computational multiphase fluid modelling will be used to analyse the sedimentation of particles. At all these scales, we will consider the behaviour of sedimenting proppant particles at higher Reynolds number and/or in a visco-elastic medium. The creation of porous beds, also for polydisperse mixtures of grain-sizes, and the distribution of proppant in a network of fractures will be investigated.

PROGRESS

Literature review of different Immersed Boundary Methods (IBM) used to take into account the fluid-structure interaction. Courses on CFD of multiphase flows and numerical methods to improve professional knowledge. Implementation of IBM for moving solid particles in a fluid.

DISSERTATIONS

-

SCIENTIFIC PUBLICATIONS

-

PROJECT LEADERS

EAJF Peters, JT Padding

RESEARCH THEME

Mathematical and computational methods for fluid flow analysis

PARTICIPANTS

R Maitri, JAM Kuipers

COOPERATIONS

Dr. Johan Romate- SHELL

FUNDED

| | |
|---------------|------|
| FOM, Industry | - |
| University | - |
| FOM | 50 % |
| STW | - |
| NWO Other | - |
| Industry | 50 % |
| TNO | - |
| GTI | - |
| EU | - |
| Scholarships | - |

START OF THE PROJECT

2014

INFORMATION

R Maitri

040 247 4487

r.maitri@tue.nl

MULTI-SCALE MODELING OF MASS AND HEAT TRANSFER IN DENSE GAS-SOLID FLOWS: DIRECT NUMERICAL SIMULATIONS

PROJECT LEADERS

JAM Kuipers

RESEARCH THEME

Complex dynamics of fluids

PARTICIPANTS

MA van der Hoef, EAJF Peters, Y Tang

COOPERATIONS

-

FUNDED

ERC

University -

FOM -

STW -

NWO Other -

Industry -

TNO -

GTI -

EU 100 %

Scholarships -

START OF THE PROJECT

2011

INFORMATION

JAM Kuipers

040 247 4158

J.A.M.Kuipers@TUE.nl

www.chem.tue.nl/smr

PROJECT AIM

This project is aimed at providing a comprehensive understanding of large-scale dense gas-solid flows based on first principles, which means the exchange of mass, momentum and heat at the surface of the individual solid particles.

PROGRESS

Immersed Boundary Method (IBM) is applied to perform direct numerical simulations of gas-solid flows in this project. The grid dependency of this method has been first studied, which gave us insight for developing a methodology to obtain highly accurate results of the gas-solid drag force. This methodology has been applied to compute the drag force in the flow past random arrays of stationary spheres with a wide range of solids volume fraction ([0.1,0.6]) for Reynolds number up to 1000. A new drag correlation is obtained, which can better predict the drag in monodisperse gas-solid systems than the correlations existed in literature by far. Simulations of flows past freely moving particles have also been performed. The results for the mean drag force are compared with those acting on stationary particles, in which case, the direct effect of particle dynamics on the hydrodynamic interaction force is obtained. This effect can be included into the expression for the drag law, leading to a better prediction of the practical gas-solid systems such as in fluidized beds.

DISSERTATIONS

-

SCIENTIFIC PUBLICATIONS

1. Y. Tang, S.H.L. Kriebitzsch, E.A.J.F. Peters, M.A. van der Hoef, J.A.M. Kuipers. A Methodology for Highly Accurate Results of Direct Numerical Simulations: Drag Force in Dense Gas-Solid Flows at Intermediate Reynolds Number. *Int. J. Multiphase Flow*, 62:73-86, 2014.

MULTISCALE MODELLING OF FLUIDIZED NON-SPHERICAL PARTICLES

PROJECT AIM

The project aims at a full understanding of the hydrodynamics of fluidized beds containing non-spherical (rod-like) particles. The main task of this project is to implement a DPM code for rod-like particles, incorporate new drag relations for translational and rotational hydrodynamic forces (obtained from DNS simulations), and to validate these closures using PIV/DIA measurements in quasi-2D fluidized beds. Novel concepts will be the inclusion of wall proximity effects (e.g. lift forces and particle orientation effects) for non-spherical particles and the detection of particle orientation and angular velocity using PIV/DIA.

PROGRESS

An approach for DPM modelling of non-spherical (sphero-cylindrical) particles has been finalized. A new DPM code in C++ is under development.

DISSERTATIONS

-

SCIENTIFIC PUBLICATIONS

-

PROJECT LEADERS

JT Padding

RESEARCH THEME

Mathematical and computational methods for fluid flow analysis

PARTICIPANTS

V Mahajan, JAM Kuipers

COOPERATIONS

-

FUNDED

| | |
|--------------|-------|
| ERC | |
| University | - |
| FOM | - |
| STW | - |
| NWO Other | - |
| Industry | - |
| TNO | - |
| GTI | - |
| EU | 100 % |
| Scholarships | - |

START OF THE PROJECT

2014

INFORMATION

V Mahajan

040 247 3295

v.v.mahajan@tue.nl

www.tue.nl/en/university/

[departments/chemical-engineering-and-chemistry/the-department/staff / detail/ep/e/d/ep-uid/20122987/](http://departments/chemical-engineering-and-chemistry/the-department/staff/detail/ep/e/d/ep-uid/20122987/)

MC-DNS STUDY OF COUPLED HEAT AND MASS TRANSFER WITH CATALYTIC SURFACE REACTION

PROJECT LEADERS

JAM Kuipers

RESEARCH THEME

Complex dynamics of fluids

PARTICIPANTS

EAJF Peters, RE Bulo, RA van Santen

COOPERATIONS

University Utrecht

FUNDED

Netherlands Center for Multiscale

Catalytic Energy Conversion

University -

FOM -

STW -

NWO Other 100 %

Industry -

TNO -

GTI -

EU -

Scholarships -

START OF THE PROJECT

2014

INFORMATION

J Lu

040 247 8868

j.lu1@tue.nl

www.tue.nl/universiteit/faculteiten/scheikundige-technologie/

de-faculteit/medewerkers/details/

ep/e/d/ep-uid/20149578/

PROJECT AIM

Quantitatively model the mass transport chain for realistic processes with multicomponent reactant and product mixtures, polydispersed particles and catalytic reaction kinetics. With this full synthesized model, it is expected to give prediction of the performance of an industrial catalytic conversion process by computer simulation, which will give insight in the interplay of transport and reactivity, and therefore real chemical processes can be optimized.

PROGRESS

Literature review of different Immersed Boundary Methods used in fluid-solid flow simulation. Tutorials and lectures to improve professional knowledge. Code learning and implementation of mass transport equation.

DISSERTATIONS

-

SCIENTIFIC PUBLICATIONS

-

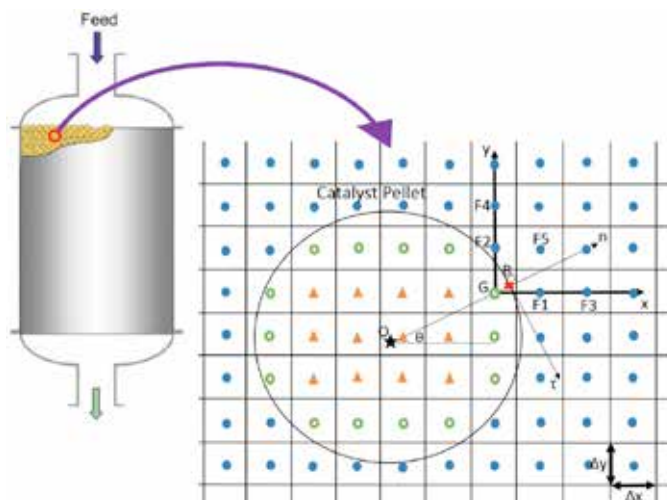

MRI FLOW IMAGING IN DENSE GAS-SOLID FLUIDIZED BEDS

PROJECT AIM

The flow systems in most chemical processes are multiphase flows and not transparent. We will develop a MRI flow imaging tool that can visualize the flow, which we cannot see with optical (camera) techniques. This tool will be used to provide high quality data sets that can be used to validate complex computational flow models of the chemical processes studied within the Gravitation Programme.

PROGRESS

A literature survey has been performed to design an experimental setup, suitable for MRI, where gas solid fluidization takes place. A Perspex cylindrical column, with an adequate size to fit in the bore of a vertical MRI scanner, is under construction and SF₆ (sulfur hexafluoride) has been chosen as a fluidizing gas, for imaging purposes.

DISSERTATIONS

-

SCIENTIFIC PUBLICATIONS

-

PROJECT LEADERS

NG Deen, JAM Kuipers, L Pel

RESEARCH THEME

Complex dynamics of fluids

PARTICIPANTS

P Lovreglio

COOPERATIONS

-

FUNDED

| | |
|--------------|-------|
| MCEC | - |
| University | - |
| FOM | - |
| STW | - |
| NWO Other | - |
| Industry | - |
| TNO | - |
| GTI | - |
| EU | 100 % |
| Scholarships | - |

START OF THE PROJECT

2014

INFORMATION

P Lovreglio
040 247 8871
p.lovreglio@tue.nl
www.tue.nl/staff/P.Lovreglio

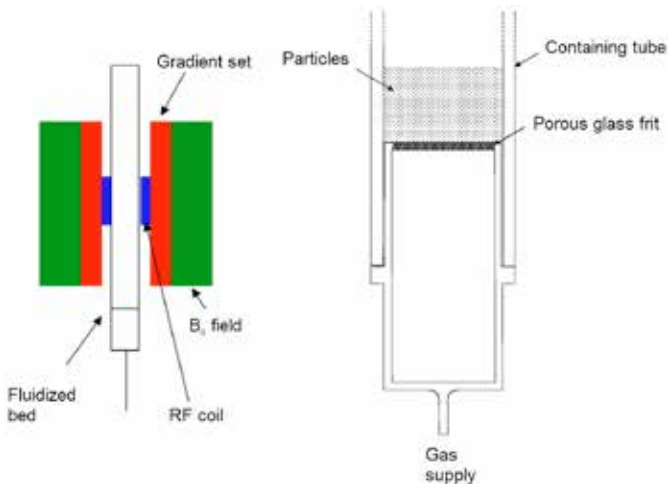

DIRECT NUMERICAL SIMULATION (DNS) OF TRANSPORT AND CHEMICAL REACTION IN THREE-PHASE FLOWS

PROJECT LEADERS

JAM Kuipers, NG Deen

RESEARCH THEME

Mathematical and computational methods for fluid flow analysis

PARTICIPANTS

Md. Shafiu Islam

COOPERATIONS

-

FUNDED

NWO

University -

FOM -

STW -

NWO Other 100 %

Industry -

TNO -

GTI -

EU -

Scholarships -

START OF THE PROJECT

2014

INFORMATION

Md. Shafiu Islam

06 28295759

m.s.islam@tue.nl

www.tue.nl/staff/m.s.islam

PROJECT AIM

Direct Numerical Simulation (DNS) techniques (i.e. front tracking, FT; volume of fluid, VOF; immersed boundary method; IB) will be used to simulate GLS (Gas-Liquid-Solid) flows involving mass, momentum and heat transport and chemical reaction in periodic domains. The main objective is to obtain closures for transfer terms from the DNS simulation results for the regime of high dispersed phase volume fractions (i.e. up to 50%).

PROGRESS

A literature review on front tracking method (FT) and mass transfer procedure of a rising bubble has been performed during this period of my PhD. Many researchers of past decade focused on their implementation of bubble column by using the fine grid DNS simulation which is computationally expensive. For the present moment, we are implementing the mass transfer procedure by following the boundary layer method where a coarse grid is employed in the flow domain. This results in an computational inexpensive approach to resolve the mass boundary layer of a rising bubble.

DISSERTATIONS

-

SCIENTIFIC PUBLICATIONS

-

MULTISCALE EXPERIMENTS AND SIMULATIONS OF AGGLOMERATION IN SPRAY DRIERS

PROJECT AIM

The main goal of the project is to provide Tetra Pak with experimentally validated predictive computational tools that can be used to tailor spray drier operations.

PROGRESS

Initial focus on the effect of viscosity on droplet collision regimes.

DISSERTATIONS

-

SCIENTIFIC PUBLICATIONS

-

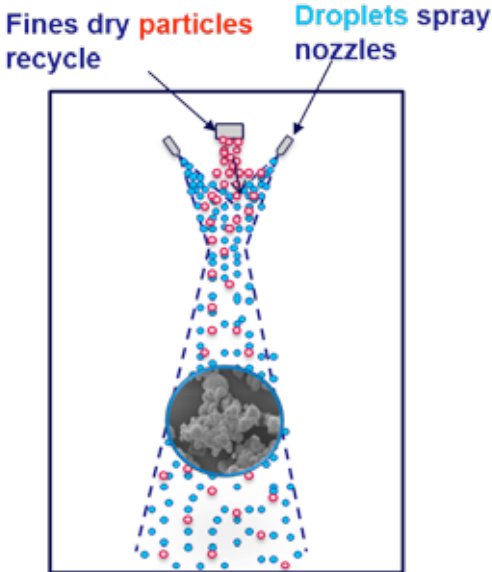

PROJECT LEADERS

JAM Kuipers, NG Deen, JT Padding

RESEARCH THEME

Mathematical and computational methods for fluid flow analysis

PARTICIPANTS

G Finotello

COOPERATIONS

Tetra Pak

FUNDED

Tetra Pak

University -

FOM -

STW -

NWO Other -

Industry 100 %

TNO -

GTI -

EU -

Scholarships -

START OF THE PROJECT

2014

INFORMATION

G Finotello

040 247 2589

G.Finotello@tue.nl

www.tue.nl/universiteit/faculteiten/scheikundige-technologie/

de-faculteit/medewerkers/details/

ep/e/d/ep-uid/20141511/

PROJECT LEADERS

JT Padding, EAJF Peters

RESEARCH THEME

Mathematical and computational methods for fluid flow analysis

PARTICIPANTS

S De, JAM Kuipers

COOPERATIONS

Dr. Albert Janssen- SHELL

FUNDED

| | |
|---------------|------|
| FOM, Industry | |
| University | - |
| FOM | 50 % |
| STW | - |
| NWO Other | - |
| Industry | 50 % |
| TNO | - |
| GTI | - |
| EU | - |
| Scholarships | - |

START OF THE PROJECT

2013

INFORMATION

JAM Kuipers
040 247 4158
j.a.m.kuipers@tue.nl

PROJECT AIM

Polymer liquids are used in the oil industry to improve the volumetric sweep efficiency and displacement efficiency of the oil from a reservoir. Surprisingly, it is not only the viscosity but also the elastic properties of the displacing fluid that determine the displacement efficiency. This may be caused by the ability of a viscoelastic fluid to pull oil out of dead-ends. The objective of the project is to develop a computer simulation methodology for the flow of non-Newtonian fluids through porous media. This will enable us to gain a fundamental understanding of the effects of fluid elasticity and interfacial tension between the oil phase and the displacing fluid on the recovery efficiencies.

PROGRESS

To understand the flow of polymers through a porous media and explain the viscoelastic effects a 3D Computational Fluid Dynamics (CFD) based code has been developed. Advanced Maxwell models (FENE-P, PTT Models) which can capture shear and extensional viscosity of polymer have been incorporated in the model. This model has been verified with analytical solution as well as published literature. A second order IBM method has been implemented, to model the porous media. This code is now used to study and obtain insights of flow, pressure and stress profiles in a model porous media. Rheological experiments are currently performed to determine the shear and extensional rheology of polymer, which are parameters of the current model.

It has been observed that salt has an effect on the polymer viscosity. To capture this a constitutive model has been developed from first principles. This model is currently validated using experimental dataset. The effect of electrolytes on flow and stress properties will also be studied using this novel model.

A set up for micro-PIV based experiments using porous micro channels has been developed. A set of experiments with Newtonian and Viscoelastic fluids has been performed to obtain more insights into the hydrodynamics for different polymer rheology.

DISSERTATIONS

-

SCIENTIFIC PUBLICATIONS

1. S. De1, J.T. Padding1, E.A.J.F. Peters1, J.A.M. Kuipers1, Viscoelastic Flow Modelling for Polymer Flooding. Poster : Proceedings of the NPS14 conference, 3-5 November 2014, Utrecht, The Netherlands.

MULTI-SCALE MODELLING OF MASS, MOMENTUM AND HEAT TRANSFER IN ADSORPTION DRYERS

PROJECT AIM

The objectives of the proposed research is the development of a comprehensive software tool that enables the calculation of an adsorption dryer device that can be used for optimization of existing units and explore the feasibility for specific future customer needs. The validated model is expected to serve as a workhorse in should include all relevant physical phenomena of the process including mass, momentum and heat transfer prevailing at different time and length scales.

PROGRESS

1D/2D models have been established and implemented. The results of a 1D model using the triangular tube Nusselt and Sherwood numbers match the experimental data very well. A 2D model based on a circular tube produces the same results to those of the 1D model, which used the circular tube Nusselt and Sherwood numbers. The results achieved provide good confidence in the model equations and implementation. A 3D model based on the triangular tube was implemented too, and is still being fully validated.

DISSERTATIONS

-

SCIENTIFIC PUBLICATIONS

-

PROJECTLEADERS

JAM Kuipers

RESEARCHTHEME

Mathematical and computational methods for fluid flow analysis

PARTICIPANTS

D Cheng, EAJF Peters

COOPERATIONS

-

FUNDED

| | |
|---------------------------------|-------|
| Atlas Copco Airpower University | - |
| FOM | - |
| STW | - |
| NWO Other | - |
| Industry | 100 % |
| TNO | - |
| GTI | - |
| EU | - |
| Scholarships | - |

START OF THE PROJECT

2014

INFORMATION

JAM Kuipers

040 247 4158

j.a.m.kuipers@tue.nl

https://venus.tue.nl/ep-cgi/ep_detail.opl?taal=US&fac_id=96&voor_org_id=&rn=20102383#

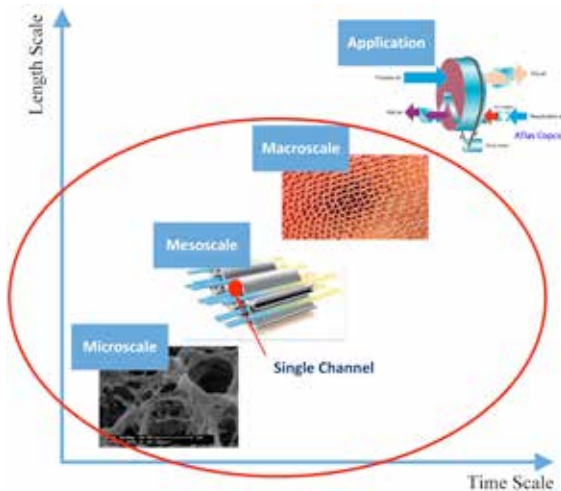

PROJECT LEADERS

JAM Kuipers

RESEARCH THEME

Mathematical and computational
methods for fluid flow analysis

PARTICIPANTS

A Carlos Varas, EAJF Peters

COOPERATIONS

-

FUNDED

MWO

University -

FOM -

STW -

NWO Other 100 %

Industry -

TNO -

GTI -

EU -

Scholarships -

START OF THE PROJECT

2013

INFORMATION

A Carlos Varas

06 19804533

a.e.carlos.varas@tue.nl

[https://venus.tue.nl/ep-cgi/ep_detail.](https://venus.tue.nl/ep-cgi/ep_detail.opl?taal=US&fac_id=96&voor_org_id=&m=20100924)

[opl?taal=US&fac_id=96&voor_org_](https://venus.tue.nl/ep-cgi/ep_detail.opl?taal=US&fac_id=96&voor_org_id=&m=20100924)

[id=&m=20100924](https://venus.tue.nl/ep-cgi/ep_detail.opl?taal=US&fac_id=96&voor_org_id=&m=20100924)

PROJECT AIM

The objective of the project is to conduct a combined experimental and computational investigation on the impact of heterogeneity on riser reactor performance. A laboratory scale riser set up is used to characterize the hydrodynamics and particle-cluster formation using image-velocimetry combined with digital image analysis. Mass transfer characteristics are measured by using ozone decomposition by catalyst particles. CFD-DEM simulations will be performed and validated using the experimental data.

PROGRESS

The diffusion-convection has been implemented in the CFD-DEM code to simulate mass transfer in riser reactors. A pseudo-2D circulating fluidized bed has been designed and constructed to perform hydrodynamic and mass transfer experiments. A novel DIA technique has been developed to measure the solids volume fraction in riser reactors. This technique is independent of the changing solids weight in the system and significantly improves the accuracy compared to existing DIA techniques.

DISSERTATIONS

-

SCIENTIFIC PUBLICATIONS

-

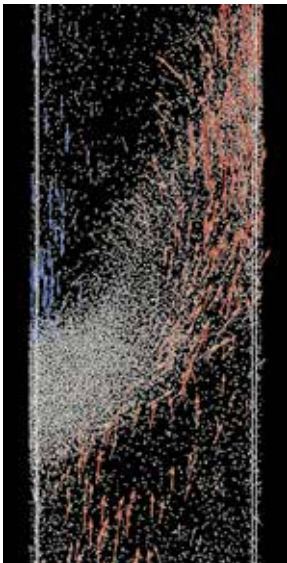

NOVEL EXPERIMENTAL TECHNIQUES FOR DENSE GRANULAR FLOW

PROJECT AIM

The primary objective of this study is to develop new experimental techniques to study particle-fluid interactions (heat transfer). The second goal is to use these techniques to complement and validate the knowledge gained with the multi-scale modelling approach.

PROGRESS

Last year has been spend to further develop a new particle tracking technique, called Magnetic Particle Tracking. The first findings have been reported in AIChE journal. Experiments have been performed to study the rotation of particles in a fluidized bed, the findings have been compared to discrete particle simulations. The results of this are currently written down and will be submitted to AIChE. Secondly, a novel setup has been developed and tested to study heat transfer in semi-structured arrays. We are currently in the progress of finalizing our experiments and comparison to direct numerical simulations.

DISSERTATIONS

-

SCIENTIFIC PUBLICATIONS

1. Buist, K.A., Gaag, A.C. van der, Deen, N.G. & Kuipers, J.A.M. (2014). Improved magnetic particle tracking technique in dense gas fluidized beds. AIChE Journal : Chemical Engineering Research and Development, 60(9), 3133-3142.

PROJECTLEADERS

JAM Kuipers

RESEARCHTHEME

Complex dynamics of fluids

PARTICIPANTS

KA Buist, NG Deen

COOPERATIONS

-

FUNDED

| | |
|--------------|-------|
| ERC | - |
| University | - |
| FOM | - |
| STW | - |
| NWO Other | - |
| Industry | - |
| TNO | - |
| GTI | - |
| EU | 100 % |
| Scholarships | - |

START OF THE PROJECT

2012

INFORMATION

KA Buist
040 247 8021
K.A.Buist@tue.nl
www.tue.nl





Prof.dr. WJ Briels

The Computational BioPhysics group (CBP) at the University of Twente is interested in the rheological and thermodynamical properties of complex soft matter. Typical multiphase systems being studied include dispersions of hard particles, e.g. spherical colloids or rod-like fd viruses, dispersed in Newtonian and non-Newtonian liquids. Close to equilibrium, the rheological properties are determined by the structural properties of the dispersed phase. Since these structures are usually stabilized by free energies in the order of several kT , they can easily be perturbed by applying flow gradients, which thus give rise to flow-induced modifications of the rheological properties. Well known phenomena resulting from this interplay between structure and flow are shear thinning, shear banding and temporal oscillations of optical and rheological properties in liquid crystalline polymer solutions. Self-assembly plays an important role in a number of systems being studied, ranging from surfactant-based worm-like micelles and lipid bilayers to various proteins that form neatly ordered structures, e.g. fibers and cages, or merely aggregate into disordered protein plaques. We are also interested in the rheology of linear and branched polymers, and the role played herein by entanglements.

The tools that we use belong to the field of particle based computer simulations. Since a full description of the observed phenomena requires a multi-scale approach, our simulation methods range from Molecular Dynamics (MD) and Monte Carlo (MC) to Multi Particle Collision Dynamics (MPCD) and Brownian Dynamics (BD). Detailed atomistic simulations are used to calculate the free energies that constitute the main interactions in subsequent simulations at a mesoscopic level. Our main strength is in developing new methods for (highly) coarse-grained simulations. We have, for instance, developed the twentanglement algorithm to investigate entangled melts of linear and branched polymers, introduced event-driven BD algorithms to simulate colloidal suspensions, developed Responsive Particle Dynamics (RaPiD) to study the flow properties of several non-linear fluids, and extended the patchy-particle approach to non-spherical particles to simulate self-assembly of protein clusters.

A SINGLE-MOLECULE VIEW ON PROTEIN AGGREGATION – SIMULATIONS OF ALPHA-SYNUCLEIN AGGREGATE FORMATION

PROJECT AIM

The ambition of this program is to unravel the physical mechanisms that underlie the dynamics of nucleation and formation of early aggregate species. To gain insight we are developing a novel highly coarse-grain modeling technique, specifically aimed at the secondary and tertiary structure of proteins, to simulate and explore the formation and structure of alpha-synuclein aggregates.

PROGRESS

We have developed a highly coarse-grained model by representing consecutive protein sequences of 10 to 15 amino-acids as soft or rigid bodies with attractive patches on their surfaces. To simulate dynamics we have implemented a Brownian Dynamics algorithm for the translational and the rotational motion. We have combined it with patchy particles models allowing generic isotropic and directional patch-patch interactions.

We have implemented this method for the self-assembly of proteins into fibrillar structures.

DISSERTATIONS

-

SCIENTIFIC PUBLICATIONS

1. I.M.Ilie, W.K. den Otter and W.J. Briels, Rotational Brownian Dynamics of Clathrin Cage Formation, J.Chem. Phys., 141, 065101, (2014).

PROJECTLEADERS

WJ Briels, WK den Otter

RESEARCHTHEME

Complex structures of fluids

PARTICIPANTS

IM Ilie

COOPERATIONS

V Subramaniam, PG Bolhuis,
M Huber, TJAartsma, GW Canters,
P Heutink, SJ Tans

FUNDED

| | |
|--------------|-------|
| FOM | |
| University | - |
| FOM | 100 % |
| STW | - |
| NWO Other | - |
| Industry | - |
| TNO | - |
| GTI | - |
| EU | - |
| Scholarships | - |

START OF THE PROJECT

2011

INFORMATION

WJ Briels
053 489 2947
w.j.briels@utwente.nl
<http://cbp.tnw.utwente.nl>

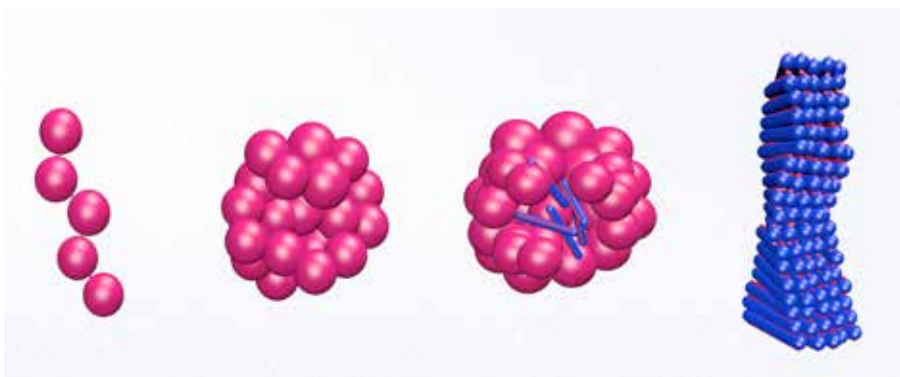

PARTICLE-BASED SIMULATIONS OF SINGLE-PHASE AND MULTI-PHASE NON-NEWTONIAN FLOW THROUGH POROUS MEDIA

PROJECT LEADERS

WJ Briels, J van der Gucht

RESEARCH THEME

Complex dynamics of fluids

PARTICIPANTS

VR Ahuja

COOPERATIONS

Interaction and data exchange with Shell Research Centres

FUNDED

Shell - NWO / FOM Programme:
'Computational Sciences for Energy Research' (CSER)

| | |
|--------------|------|
| University | - |
| FOM | 50 % |
| STW | - |
| NWO Other | - |
| Industry | 50 % |
| TNO | - |
| GTI | - |
| EU | - |
| Scholarships | - |

START OF THE PROJECT

2013

INFORMATION

WJ Briels

053 489 2947

w.j.briels@utwente.nl

<http://cbp.tnw.utwente.nl>

PROJECT AIM

The aim of this project is to study one-phase and two-phase flow of non-Newtonian fluids through porous media using Responsive Particle Dynamics (RaPiD), a particle-based simulation method that can handle soft matter systems with spatial and temporal memory in any geometry. This is relevant for example in polymer flooding, which is an Enhanced Oil Recovery (EOR) technique where a small amount of polymer is added to the injection water to modify its flow properties leading to viscoelastic effects thereby improving the volumetric sweep efficiency in the oil reservoir.

PROGRESS

We have used Responsive Particle Dynamics (RaPiD)[1] to model FLOPAAM, a polymer solution used in Enhanced Oil Recovery (EOR) to match the experimental data of loss and storage moduli for the polymer solution. We have also validated our model by comparing the prediction of non-linear dynamics viz. the shear thinning behavior of the polymer solution from the model vis-a-vis the experimental data. Furthermore, we have incorporated into the model a two-way coupling algorithm[2] which couples the coarse-grain motion of the polymer molecules with the flow of the background fluid implicitly present in RaPiD. Moreover, we have also incorporated the effect of a solid boundary by incorporating phantom particles into the solid which offer 'friction' to the flow of the background fluid thereby accounting for solid-fluid interactions at solid interfaces.

DISSERTATIONS

-

SCIENTIFIC PUBLICATIONS

1. Padding, J. T., & Briels, W. J. (2014). Momentum conserving Brownian dynamics propagator for complex soft matter fluids. *The Journal of chemical physics*, 141(24), 244108.



Prof.dr. D Lohse



Prof.dr.ir. D van der Meer



Prof.dr.ir. J Snoeijer



Prof.dr. M Versluis



Prof.dr. J Harting



Prof.dr. X Zhang

The Physics of Fluids group in Twente works on a variety of aspects in fluid mechanics, in particular on those related to bubbles. The focus of our work is the fundamental understanding the phenomena of the physics of fluids, bubbles and jets, which we undertake by experimental, numerical and theoretical means. Besides in the J.M.Burgers Center, our research is embedded in the Research Institute of Mechanics, Processes and Control IMPACT, the MESA+ Institute, and the Research Institute for Biomedical Technology BMTi of the University of Twente. The group receives external research funds mainly from FOM, but also from STW, NWO, SenterNovem, EU and several companies. The focus research areas of the group are:

TURBULENCE AND TWO-PHASE FLOW

Fully developed turbulence is one of the big unsolved problems in fluid dynamics. The main question is the distribution of rare events, which has important implications for, e.g., flight safety. We approach this problem from a fundamental point of view, both experimentally, theoretically, and numerically. One particular important type of turbulence is turbulence (partly) driven by body forces, such as buoyancy. This can happen by either thermally driving the turbulence or also by driving the turbulence through bubbles or dispersed particles. Both will be advected by the flow but also act back on the surrounding liquid (two-way coupling). To be able to describe flow with many bubbles or particles efficiently, one needs an effective force description, on which and with which we work in several projects within our group. Finally, we are also interested in the radial dynamics of single bubbles in hydrodynamic or acoustic fields.

GRANULAR FLOW

Granular flows are fundamentally different from any other type of flow. In our research we focus on the clustering phenomenon that finds its origin in the inelastic collisions between the particles. There is much emphasis on the onset of clustering, which happens via a phase transition which is studied in both compartmentalized and continuous systems. Another line of our research deals with the impact of objects on very fine, decompactified sand, in which we explore the applicability of fluid models to granular systems. We uncovered links to distant phenomena like asteroid impact and a dry variety of quicksand.

MICRO- AND NANOFUIDICS

The physics of fluids at the microscale can be quite different from macrofluidic behavior. Here we study disturbing bubbles in microchannels found in ink jet printing. By patterning surfaces on sub-micron scales we try to identify individual 'nanobubbles' which may lead to a quantitative understanding of wall slip. These patterned surfaces may also serve as nucleation sites for cavitation bubbles generated through intense negative pressures.



Prof.dr. JF Dijkman



Prof.dr.ir. L van Wijngaarden



Prof.dr. A Prosperetti



Prof.dr. R Verzicco

BIOMEDICAL FLOW

Bubbles have various applications in the biomedical field. Coated microbubbles are used in ultrasound imaging to enhance the contrast in cardiac or liver perfusion images. Bubbles can be targeted to specific cells for molecular imaging to non-invasively detect the presence and location of diseases such as cancer or atherosclerosis. Furthermore, the bubbles can be exploited to generate acoustic streaming and jetting near cell boundaries which leads to permeation, destruction or removal of target cells.

TURBULENT TAYLOR-COUPETTE FLOW AND RAYLEIGH-BÉNARD CONVECTION

PROJECT AIM

The aim is to study numerically Taylor-Couette flow and Rayleigh-Bénard convection at turbulent driving. Studying the dynamics of boundary layers, large scale circulations and plumes and using the observations to predict (their effect) on heat flux or torque scaling laws. In particular, the scaling of global quantities to arbitrary driving is of interest. The region where scaling no longer changes is called 'the ultimate regime'.

PROGRESS

In Taylor-Couette flow the ultimate has been observed numerically, confirming experimental results. Numerical access to this regime has allowed the exhaustive study on all the relevant quantities, characteristic of simulations. The gradual transition of the boundary layer to a turbulent one has been elucidated and the transition has been carefully conceptualized in a comprehensive phase diagram. As Rayleigh-Bénard convection has been shown to be analogous to Taylor-Couette flow, it is expected that also there a transition exists that can be observed numerically. However, Rayleigh-Bénard convection requires even higher driving, complicating analysis. Studying the effect of the boundary conditions on the flow and the implication for the computational cost has lighted the most efficient path towards reaching the ultimate regime.

DISSERTATIONS

-

SCIENTIFIC PUBLICATIONS

1. Rodolfo Ostilla-Mónico, Erwin P. van der Poel, Roberto Verzicco, Siegfried Grossmann and Detlef Lohse (2014). Boundary layer dynamics at the transition between the classical and the ultimate regime of Taylor-Couette flow. *Phys. Fluids* 26, 015114.
2. Rodolfo Ostilla-Mónico, Roberto Verzicco, Siegfried Grossmann and Detlef Lohse (2014). Turbulence decay towards the linearly stable regime of Taylor-Couette flow. *Journal of Fluid Mechanics*, 748, R3.
3. Erwin P. van der Poel, Rodolfo Ostilla-Mónico, Roberto Verzicco, and Detlef Lohse (2014). Effect of velocity boundary conditions on the heat transfer and flow topology in two-dimensional Rayleigh-Bénard convection. *Phys. Rev. E* 90, 013017.
4. Rodolfo Ostilla-Mónico, Erwin P. van der Poel, Roberto Verzicco, Siegfried Grossmann and Detlef Lohse (2014). Exploring the phase diagram of fully turbulent Taylor-Couette flow. *Journal of Fluid Mechanics*, 761, pp 1-26.
5. Rodolfo Ostilla-Mónico, Sander G. Huisman, Tim J.G. Jannink, Dennis P.M. Van Gils, Roberto Verzicco, Siegfried Grossmann, Chao Sun and Detlef Lohse (2014). Optimal Taylor-Couette flow: radius ratio dependence. *Journal of Fluid Mechanics*, 747, pp 1-29.

PROJECT LEADERS

D Lohse

RESEARCH THEME

Mathematical and computational methods for fluid flow analysis

PARTICIPANTS

EP van der Poel, R Ostilla-Mónico

COOPERATIONS

-

FUNDED

| | |
|--------------|------|
| FOM, EU | |
| University | - |
| FOM | 50 % |
| STW | - |
| NWO Other | - |
| Industry | - |
| TNO | - |
| GTI | - |
| EU | 50 % |
| Scholarships | - |

START OF THE PROJECT

2011

INFORMATION

D Lohse

053 489 8076

d.lohse@utwente.nl

pof.tnw.utwente.nl

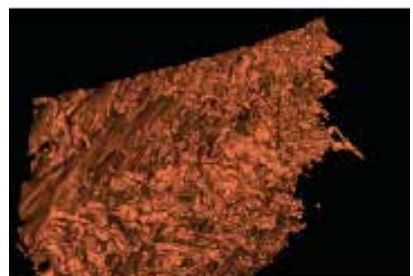

INKJET PRINTING OF SUSPENSIONS

PROJECT LEADERS

D Lohse, JH Snoeijer, JF Dijkman

RESEARCH THEME

Complex dynamics of fluids

PARTICIPANTS

MJ Thoraval, E Sandoval

COOPERATIONS

Holst Center, Dutch Polymer Institute

FUNDED

Holst Center, Dutch Polymer Institute

University -

FOM -

STW -

NWO Other -

Industry 50 %

TNO 50 %

GTI -

EU -

Scholarships -

START OF THE PROJECT

2012

INFORMATION

D Lohse

053 489 8076

d.lohse@utwente.nl

pof.tnw.utwente.nl

PROJECT AIM

Inkjet printing is considered the contender of choice for the manufacturing of low-cost and large-area electronics, such as for disposable medical devices, radio-frequency applications for theft protection in shops, polymer LED based lighting devices, and solar cells. The idea is to make these devices on roll-to-roll equipment: the components of the electronic structures are deposited by means of inkjet printing, which can be scaled to any deposition rate by adding either extra nozzles or extra print heads and to adjust the droplet volume.

PROGRESS

The last meeting has oriented the efforts of the last period on two main targets:

- Explore the possibility of using jetting as a rheometer. Indeed, the high shear rates encountered in the jetting are not accessible with conventional rheometers.

- Investigate the splashing – non-splashing transition of silver nano-suspension when increasing the droplet impact velocity. This behavior is very surprising and was not reported before. It will help us understand the physics of splashing.

DISSERTATIONS

-

SCIENTIFIC PUBLICATIONS

-

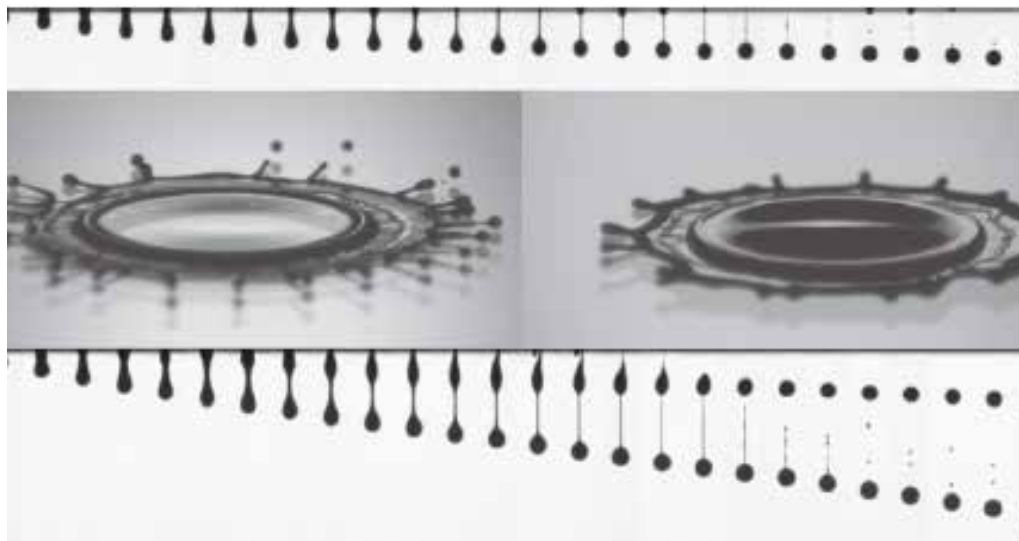

THE ROLE OF VAPOR/AIR LAYER IN DROPLET-SURFACE INTERACTIONS

PROJECT AIM

(1) To study the air entrainment and splashing processes of impacting droplet on various kinds of surfaces: smooth solid surfaces, micro-structured solid surfaces, solid surfaces covered by a thin liquid film, liquid surfaces.

(2) To study the boiling and hydrodynamic processes of liquid droplets on superheated surfaces, in particular, the role of the vapour layer in affecting the spreading and boiling behaviours of droplets.

PROGRESS

Highlights:

- Laser total internal reflection method to measure the wetting on heated substrates under impacting droplets.
- Study of dynamic Leidenfrost temperature for various thermal conducting materials.
- Splashing threshold and mechanism of impacting Leidenfrost droplet.
- Fragmentation of droplet in the contact boiling regime.

DISSERTATIONS

-

SCIENTIFIC PUBLICATIONS

-

PROJECT LEADERS

D Lohse, C Sun

RESEARCH THEME

Complex dynamics of fluids

PARTICIPANTS

MAJ van Limbeek, D Lohse, A Prosperetti, M Shirota, HJJ Staat, C Sun

COOPERATIONS

-

FUNDED

| | |
|--------------|-------|
| FOM | |
| University | - |
| FOM | 100 % |
| STW | - |
| NWO Other | - |
| Industry | - |
| TNO | - |
| GTI | - |
| EU | - |
| Scholarships | - |

START OF THE PROJECT

2011

INFORMATION

C Sun
053 489 5604
c.sun@utwente.nl
<http://pof.tnw.utwente.nl>

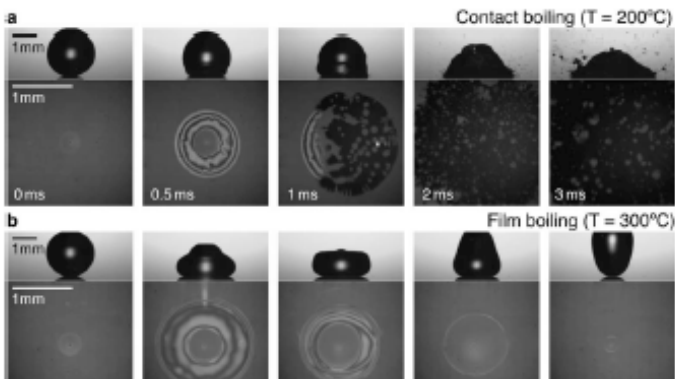

Representative series of snapshots during impact taken from the side and the bottom-views showing spreading and boiling processes of droplet impact on a smooth sapphire surface in (a) contact boiling regime, and (b) film boiling regime.

PROJECT LEADERS

D Lohse, C Sun

RESEARCH THEME

Complex dynamics of fluids

PARTICIPANTS

CW Visser

COOPERATIONS

LAM research, Austria; Georg August Universität, Göttingen; Developmental BioEngineering group, UT.

FUNDED

| | |
|--------------|-------|
| FOM | |
| University | - |
| FOM | 100 % |
| STW | - |
| NWO Other | - |
| Industry | - |
| TNO | - |
| GTI | - |
| EU | - |
| Scholarships | - |

START OF THE PROJECT

2011

INFORMATION

Chao Sun
c.sun@utwente.nl
pof.tnw.utwente.nl

PROJECT AIM

- (1) To study and optimize the generation of extremely fast laser-induced microjets;
- (2) Study the impact of these jets and the impact of jet-generated droplets.

PROGRESS

Highlights:

- Metal micro-droplets were ejected and stacked. The ejection was visualized in detail and published in Physical Review Applied. The stacking was achieved for the first time, enabling 3D printing of pure metals such as copper and gold. A publication is in progress.
- The impact of cell-containing droplets was studied. The cell survival was experimentally assessed as a function of the drop impact speed, the drop size, viscosity, and the substrate stiffness. An analytical model to describe the cell survival was developed and presented at the Biofabrication conference in Deagu, South Korea. A publication is in progress.

DISSERTATIONS

1. Fundamental and applications of fast micro-drop impact, Claas Willem Visser, 2014.

SCIENTIFIC PUBLICATIONS

1. Visser, C.W., Frommhold, P., Mettin, R., Wildeman, S., Sun, C., & Lohse, D. "Dynamics of high-speed micro-drop impact: Numerical simulations and experiments at frame-to-frame times below 100ns", Soft Matter, published online in December 2014.
2. Pohl, R., Visser, C.W., Römer, G.R.B.E., Sun, C., Huis in 't Veld, A.J., & Lohse, D. (2014). "Imaging of the ejection process of nanosecond laserinduced forward transfer of gold." Proceedings of LPM 2014, Vilnius, Lithuania.
3. Pohl, R., Visser, C.W., Römer, G.R.B.E., Sun, C., Huis in 't Veld, A.J., & Lohse, D. (2014). "High-resolution imaging of ejection dynamics in laser-induced forward transfer." SPIE 2014, San Francisco, USA.

Impacting micro-droplet viewed from below. Remarkably, the fringes are caused by interference between the (curved) top surface of the droplet and the (flat) impingement surface. These fringes allow to determine the droplet's surface shape with a sub-micrometer resolution. The results are described in ref. [1].

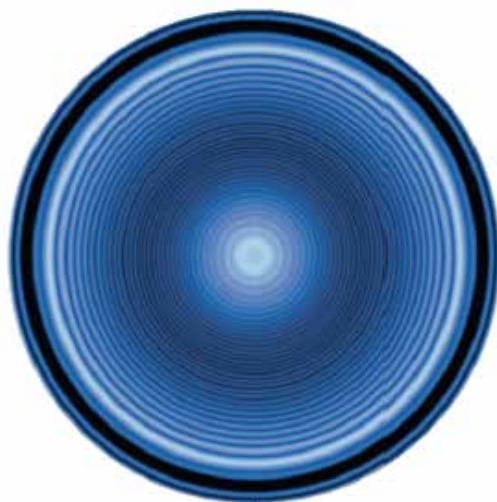

ENHANCED GROWTH OF INTERACTING BUBBLES

PROJECT AIM

The aim of the project is to improve the quantitative understanding of the physical mechanisms involved in gas exsolution and bubble formation under conditions mimicking those encountered in an oil field.

PROGRESS

We have deepened our study on the onset of natural convection around a gas bubble that grows by diffusion in a slightly supersaturated liquid. Experiments with different gas concentrations show good agreement with our theoretical prediction for the onset time. Furthermore, we have studied several cases of bubbles growing closely and interacting while they do so. We have found that, depending on the distance between them, bubbles can hinder each other's growth rates or they can develop a "cooperative" interaction. These interactions are mediated by the surrounding concentration/density profile, which is also the cause of the natural convection that always increases the growth rate of an isolated bubble.

DISSERTATIONS

-

SCIENTIFIC PUBLICATIONS

1. Á. Gómez Marín, O.R. Enríquez, P. Brunet, P. Colinet, and J.H. Snoeijer, Universality of tip singularity formation in freezing water drops, *Phys. Rev. Lett.* 113, 054301 (2014).
2. O.R. Enríquez, C. Sun, D. Lohse, A. Prosperetti, and D. van der Meer, The quasi-static growth of CO₂ bubbles, *J. Fluid Mech.* 741, R1 (2014).

PROJECT LEADERS

D Lohse, A Prosperetti, D van der Meer, C Sun

RESEARCH THEME

Complex dynamics of fluids

PARTICIPANTS

OR Enríquez

COOPERATIONS

-

FUNDED

| | |
|--------------|-------|
| Shell/FOM | |
| University | - |
| FOM | 100 % |
| STW | - |
| NWO Other | - |
| Industry | - |
| TNO | - |
| GTI | - |
| EU | - |
| Scholarships | - |

START OF THE PROJECT

2010

INFORMATION

D van der Meer
053 489 2387
d.vandermeer@utwente.nl

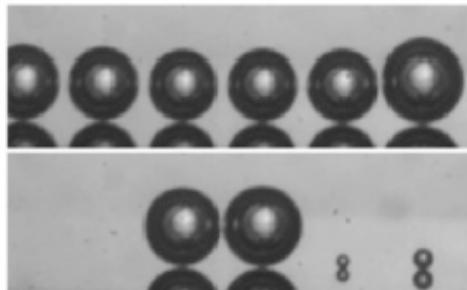
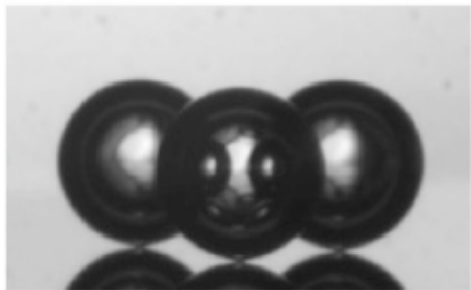

A bubble triplet in a triangular arrangement (left). The symmetry of their positions allows for an equal growth of the three bubbles. A line of closely-spaced bubbles (right). The rightmost bubble grows clearly faster than the rest due to its more "favorable" position (top). Bubbles detach after touching each other and coalescing which usually leads to synchronization between pairs of neighbors (bottom).

PROJECT LEADERS

D Lohse, HJW Zandvliet

RESEARCH THEME

Complex structures of fluids

PARTICIPANTS

S Kooij, B Poelsema, R Berkelaar,
P Bampoulis

COOPERATIONS

-

FUNDED

| | |
|--------------|-------|
| NWO Nano | |
| University | - |
| FOM | - |
| STW | - |
| NWO Other | 100 % |
| Industry | - |
| TNO | - |
| GTI | - |
| EU | - |
| Scholarships | - |

START OF THE PROJECT

2013

INFORMATION

E Dietrich
e.dietrich@utwente.nl

P Bampoulis
06 49177816
p.bampoulis@utwente.nl
pof.tnw.utwente.nl

PROJECT AIM

To study the behavior and properties of interfacial nano- and microbubbles and droplets at solid-liquid interfaces. The physics of the interfacial contact between water or air and solid surfaces are of fundamental and practical interest in many biological systems, environmental sciences, and corrosion effects. Water droplets or air bubbles intercalate between graphene and mica has recently received much interest, even amplified by intriguing intercalation effects and by the evolution of fractals. Due to its good thermal isolation from the environment, this system is uniquely suited for studying the consequences of particle and heat transport. Furthermore, in such a system ordered water layers (ice-like) that share a lot of similarities with ice/snowflakes can form at room temperature. We aim to study the intercalation effects of water/ice/air in situ, using Atomic Force Microscopy. A complete understanding is required since trapped water/air can influence or even hinder graphene's properties. Our system can also shed light to the enigmatic growth of snowflakes, a fundamental problem.

PROGRESS

An understanding of the water intercalation under graphene and mica has been achieved. We have successfully understood the counterintuitive growth of ice fractals between graphene and mica. Our contribution also provides a fundamentally new crystal growth mechanism in a highly spatially confined space and sheds light to the growth of snowflakes. Heat and particle transport play a crucial role in the growth of dendritic snowflakes under "high-temperature" and high supersaturation conditions (manuscript under preparation). More insight was obtained in the dissolution dynamics of surface micro droplets. The influence of shape, coverage, and pinning of the droplet on the dissolution process was studied. Apart from that, measurements were conducted on the substrate preparation and liquid preparation in experiments involving interfacial droplets and bubbles.

DISSERTATIONS

-

SCIENTIFIC PUBLICATIONS

1. R.P.Berkelaar, E.Dietrich, G.A.Kip, E.S.Kooij, H.J.Zandvliet, D.Lohse. Exposing nanobubble-like objects to a degassed environment. *Soft Matter*, 2014, 10, 4947-4955.
2. X. Zhang, H.Lhuissier, C.Sun, D.Lohse. Surface nanobubbles nucleate microdroplets. *Physical Review Letters*, 2014, 112, 144503-144508.
3. C.Xu, S.Peng, G.Qiao, V. Gutowski, D. Lohse. Nanobubble formation on a warmer substrate. *Soft Matter*, 2014, 10, 7857-7864.
4. H.Lhuissier, D.Lohse, X.Zhang. Spatial organization of surface nanobubbles and its implications in their formation process. *Soft Matter*, 2014, 10, 942-946.
5. X. Zhang, D.Lohse. Perspectives on surface nanobubbles. *Biomicrofluidics*, 2014, 8, 41301.

FLUID DYNAMICS IN EUV SOURCES & NOZZLES FOR NON-CIRCULAR JET BREAKUP

PROJECT AIM

The aim of the project is to provide fundamental understanding of fluid dynamics in droplet generation devices of several types, with applications in EUV lithography and medical microspray technology. Topics of this work include liquid jet breakup, droplet generation, coalescence dynamics, target shaping, plasma droplet interaction, interaction of gas flows with droplet trajectory, process stability and splashing. The project has an experimental focus, supported by theory and numerical modeling.

PROGRESS

Current work focuses on drop impact on a deep pool for low Bond numbers. Results are coming in but are not conclusive as of now.

DISSERTATIONS

-

SCIENTIFIC PUBLICATIONS

-

In the area of non-circular jet breakup, numerical work is nearing completion, showing good agreement with analytical work. Experimental work has recently begun and results are expected soon.

PROJECT LEADERS

D Lohse, JF Dijkman, M Versluis

RESEARCH THEME

Complex dynamics of fluids

PARTICIPANTS

P Sleutel, M Kok

COOPERATIONS

Ben de Smet, Michel Riepen (ASML), Herman Wijshof (Oce, NanonextNL), Jeroen Wissink (Medspray)

FUNDED

| | |
|--------------|-------|
| NanonextNL | |
| University | - |
| FOM | - |
| STW | - |
| NWO Other | - |
| Industry | 100 % |
| TNO | - |
| GTI | - |
| EU | - |
| Scholarships | - |

START OF THE PROJECT

2012

INFORMATION

P Sleutel
073 489 4213
c.p.sleutel@utwente.nl

Maarten Kok
073 489 3084
<http://pof.tnw.utwente.nl>

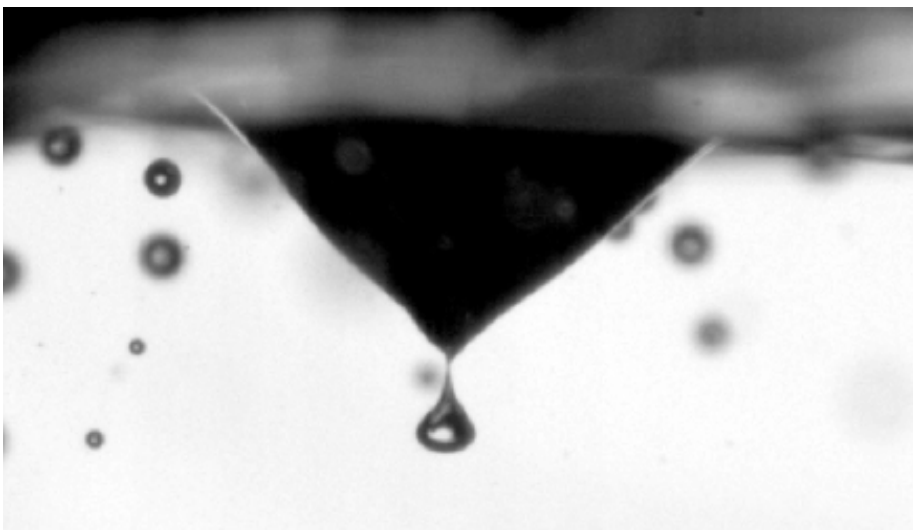

DIRECT NUMERICAL SIMULATION OF TAYLOR-COUETTE FLOW WITH GROOVES

PROJECT LEADERS

D Lohse, R Verzicco

RESEARCH THEME

Complex dynamics of fluids

PARTICIPANTS

X Zhu, R Ostilla-Monico

COOPERATIONS

-

FUNDED

FOM

University -

FOM 100 %

STW -

NWO Other -

Industry -

TNO -

GTI -

EU -

Scholarships -

START OF THE PROJECT

2014

INFORMATION

X Zhu

0615886769

Xiaojue.zhu@utwente.nl

<http://pof.tnw.utwente.nl/people/profile/857>

PROJECT AIM

(i) DNS provides us the ability to the whole details of flow velocities which are unavailable in experiments, so we can look deep into the effective scaling laws for torque, boundary layers and flow structures in Taylor-Couette flow with grooves. (ii) We want to make further analogy between Taylor-Couette and Rayleigh-Benard flow under the condition with grooves.

PROGRESS

(i) We implemented the Immersed boundary module into the so-called Verzicco code.

(ii) We found that angular velocity transport is enhanced in grooved Taylor-Couette flow.

(iii) The visualization of flow structure show that the enhanced angular velocity transport is attributed to the plumes ejection from tips of the grooves.

(iv) Correspondingly, the boundary layer dynamics is also changed according to the grooves.

DISSERTATIONS

-

SCIENTIFIC PUBLICATIONS

-

TURBULENT, BOILING AND MULTI-PHASE TAYLOR-COUPETTE FLOWS

PROJECT AIM

Taylor-Couette (TC) is the flow between two coaxial, independently rotating cylinders. As it is a closed system, global transport balances can be established, which give more insight into the fundamental behavior of the flow, as they reflect the interplay of bulk and boundary layer. We experimentally investigated the boundary layer properties in the ultimate TC regime, and quantitatively compare it to other flow-systems. Furthermore, we statistically described the properties of the turbulent flow by studying the structure functions of the velocity fluctuations at different rotations. A new TC facility that incorporates boiling and high-precision temperature control, aiming to study the fundamentals of boiling in turbulence has been constructed. In addition, we will explore the effects of bubbles, particles and droplets on the turbulent flow dynamics.

PROGRESS

S.G. Huisman has obtained his doctorate degree (Cum Laude) with the dissertation Taylor-Couette turbulence. The new TC facility that incorporates boiling and high-precision temperature control has been completed, and is now being tested and calibrated. A Nature Communications and JFM paper have been published, and other publications are in preparation.

DISSERTATIONS

1. Huisman, Sander Gerard (2014) Taylor-Couette turbulence. thesis.

SCIENTIFIC PUBLICATIONS

1. Huisman, S. G., van der Veen, R. C. A., Sun, C., & Lohse, D. (2014). Multiple states in highly turbulent Taylor–Couette flow. *Nature Communications*, 5(May), 1–5. doi:10.1038/ncomms4820.
2. Ostilla-Mónico, R., Huisman, S. G., Jannink, T. J. G., van Gils, D. P. M., Verzicco, R., Grossmann, S., ... Lohse, D. (2014). Optimal Taylor–Couette flow: radius ratio dependence. *Journal of Fluid Mechanics*, 747, 1–29. doi:10.1017/jfm.2014.134.

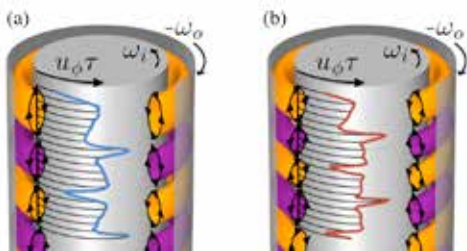

Multiple states in turbulent Taylor-Couette flow

PROJECT LEADERS

D Lohse, C Sun

RESEARCH THEME

Complex dynamics of fluids

PARTICIPANTS

S Huisman, R van der Veen, R Verschoof, R Ezeta, D Bakhuis, C Sun, D Lohse

COOPERATIONS

-

FUNDED

Simon Stevin, ERC advanced grant

| | |
|--------------|------|
| University | - |
| FOM | 50 % |
| STW | 50 % |
| NWO Other | - |
| Industry | - |
| TNO | - |
| GTI | - |
| EU | - |
| Scholarships | - |

START OF THE PROJECT

2010

INFORMATION

D Lohse
053 489 8076
d.lohse@utwente.nl
pof.tnw.utwente.nl



The new Taylor-Couette facility

HOW DO MENISCUS SHAPE INSTABILITIES LEAD TO AIR ENTRAPMENT IN PIEZO-ACOUSTIC INKJET PRINTING?

PROJECT LEADERS

D Lohse, M Versluis

RESEARCH THEME

Complex dynamics of fluids

PARTICIPANTS

A Fraters

COOPERATIONS

Océ Technologies B.V.

FUNDED

HTSM 2012: STW, Océ Technologies B.V.

University -

FOM -

STW 60 %

NWO Other -

Industry 40 %

TNO -

GTI -

EU -

Scholarships -

START OF THE PROJECT

2014

INFORMATION

A Fraters

a.b.fraters@utwente.nl

pof.tnw.utwente.nl

PROJECT AIM

The objective of this project is to understand fluid instabilities in the nozzle of a piezo-acoustic inkjet printer and be able to predict under what conditions bubble entrainment will take place.

PROGRESS

Experimental setup is being developed to look into MEMS silicon printhead with infrared light. Boundary Integral code is being adapted to simulate the meniscus motion in the inkjet setup. Research on bubble growth and motion in MEMS-size cylindrical channels is being prepared.

DISSERTATIONS

-

SCIENTIFIC PUBLICATIONS

-

CONTACT LINE CONTROL DURING WETTING AND DEWETTING

PROJECT AIM

Experimental study of the motion of the meniscus in the nozzle and asymmetric defects of the inkjet microdrop formation.

PROGRESS

A review was made of different experimental techniques, to obtain flow information from within the micro-scaled inkjet nozzles. Acceleration thresholds were determined using a simplified RT model, above which asymmetric instabilities can grow on the inkjet meniscus. These asymmetric instabilities can give rise to jetting defects. The developed experimental method to accurately obtain the radius and velocity profile of microdrops in flight, has been exploited to benchmark several CFD drop formation codes.

DISSERTATIONS

-

SCIENTIFIC PUBLICATIONS

1. YanboXie, DiederikBos, LennartdeVreede, HansdeBoer, Mark-JanvanderMeulen, Michel Versluis, Ad Sprenkels, Albert van den Berg and Jan Eijkel, High-efficiency ballistic electro- static generator using microdroplets, Nat. Commun. 5 (2014).
2. Arjan van der Bos, Mark-Jan van der Meulen, Theo Driessen, Marc van den Berg, Hans Reinten, Herman Wijshoff, Michel Versluis and Detlef Lohse, Velocity Profile inside Piezoacous- tic Inkjet Droplets in Flight: Comparison between Experiment and Numerical Simulation, Phys. Rev. Applied, 1, 014004. (2014).

PROJECTLEADERS

D Lohse

RESEARCHTHEME

Complex dynamics of fluids

PARTICIPANTS

MP van der Meulen

COOPERATIONS

Cooperation with Océ Technologies, Venlo

FUNDED

FOM-IPP, Océ Technologies

University -

FOM 50 %

STW -

NWO Other -

Industry 50 %

TNO -

GTI -

EU -

Scholarships -

START OF THE PROJECT

2011

INFORMATION

M-J van der Meulen

053 489 4473

m.p.vandermeulen@utwente.nl

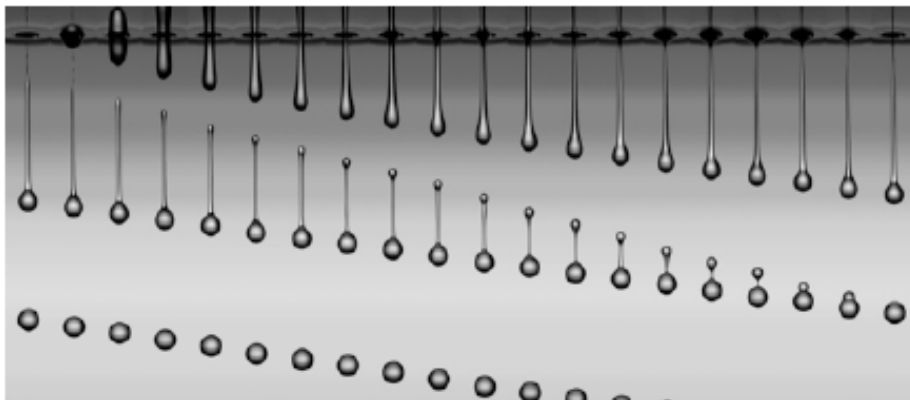

Image of the year 2014:

<http://www.nature.com/news/dummy-jpg-1-7.16344?article=1.14920>

UNDERSTANDING THE SPATIO-TEMPORAL STRUCTURE OF HIGHLY INTERMITTENT TURBULENT FLOW IN WIND FARMS: HOW TO DEAL WITH LARGE FLUCTUATIONS?

PROJECT LEADERS

RJAM Stevens

RESEARCH THEME

Complex dynamics of fluids

PARTICIPANTS

RJAM Stevens, C Meneveau (Johns Hopkins University, USA),
DF Gayme (Johns Hopkins, USA),
M Wilczek (Johns Hopkins, USA),
T Martinez (Johns Hopkins, USA), D Lohse (UT-TNW-PoF)

COOPERATIONS

RJAM Stevens, C Meneveau (Johns Hopkins University, USA),
DF Gayme (Johns Hopkins, USA),
M Wilczek (Johns Hopkins, USA),
T Martinez (Johns Hopkins, USA), D Lohse (UT-TNW-PoF)

FUNDED

| | |
|-------------------------|------|
| FOM, US funding NSF 50% | |
| University | - |
| FOM | 50 % |
| STW | - |
| NWO Other | - |
| Industry | 50 % |
| TNO | - |
| GTI | - |
| EU | - |
| Scholarships | - |

START OF THE PROJECT

2012

INFORMATION

R Stevens
053 489 2487
r.j.a.m.stevens@utwente.nl



Visualization of the low speed wind regions indicated in blue in a very large wind-farm which shows the creation of turbulent wakes behind the turbines (visualization by David Bock, NCSA Visualization, XSEDE)

PROJECT AIM

In this project we use large eddy simulations to model the interaction between wind farms with many turbine rows in the downstream direction and the atmospheric boundary layer. We focus on the effect of the layout of the wind farm on its total power output and power fluctuations. We want to understand the influence of the properties of the very large-scale motions in the atmospheric boundary layer and the role of the turbulent fluctuations on the wind farm performance. Subsequently we want to translate this understanding to simpler models that can be used to predict properties of extended wind farms.

PROGRESS

We have developed the coupled wake boundary layer model (CWBL) model that describes the power output of wind-turbines in a wind-farm as function of the main design parameters. The model combines an industry standard wake model approach with a simple 'momentum balance' based theory ('top-down' model). The wake model part captures the effect of turbine positioning, while the interaction between the wind-turbine wakes and the atmospheric boundary layer is represented in the 'top-down' part of the model. In the CWBL framework a two-way coupling procedure is used to exchange information between both model parts. Based on comparisons with large eddy simulations (LES) results of wind-farms, see figure 1, we find that the CWBL model gives improved predictions for the power output of very large wind-farms compared to the predictions of stand-alone wake and 'top-down' models. Statistical moments in boundary layers have also been studied using LES.

DISSERTATIONS

-

SCIENTIFIC PUBLICATIONS

1. R.J.A.M. Stevens, D. F. Gayme, C. Meneveau, Large eddy simulation studies of the effects of alignment and wind farm length, *J. of Renewable and Sustainable Energy* 6, 023105 (2014).
2. R.J.A.M. Stevens, J. Graham, C. Meneveau, A concurrent precursor inflow method for Large Eddy Simulations and applications to finite length wind farms, *Renewable Energy* 68, 46-50 (2014).
3. R.J.A.M. Stevens, C. Meneveau, Temporal structure of aggregate power fluctuations in large-eddy simulations of extended wind-farms, *J. of Renewable and Sustainable Energy* 6, 043102 (2014).
4. R.J.A.M. Stevens, M. Wilczek, C. Meneveau, Large-eddy simulation study of the logarithmic law for second and higher-order moments in turbulent wall-bounded flow, *J. Fluid Mech.* 757, 888-907 (2014).
5. M. Wilczek, R.J.A.M. Stevens, Y. Narita, C. Meneveau, A wavenumber-frequency spectral model for atmospheric boundary layers, *J. Phys.: Conf. Ser.* 524, 012104 (2014).
6. C. Archer, B. Colle, L. D. Monache, M. Dvorak, J. Lundquist, B. Bailey, P. Beaucage, M. Churchfield, A. Fitch, B. Kosovic, S. Lee, P. Moriarty, H. Simao, R.J.A.M. Stevens, D. Veron, J. Zack, *Meteorology for coastal/offshore wind energy in the US: Research needs for the next 10 years*, *Bull. Amer. Meteor. Soc.* 95, 515-519 (2014).

IMPACT OF RAIN DROPS ON SAND

PROJECT AIM

The impact of a liquid droplet on a layer of grains is amongst the most common events in nature. Nevertheless, surprisingly little is known about the physics that governs it. First, we want to know what causes sand and water to mix during impact? Second, when there is no mixing, what controls the amount of momentum that is transferred from the liquid to the sand? Third, how can we understand the different crater shapes that are generated? With experimental work we want to resolve these questions.

PROGRESS

In 2014, we performed experiments in a broader parameter space by changing packing fraction and impact velocity. The dynamic measurements indicate that the impact energy can be distributed into the deformation of the droplet and the deformation of the substrate. It shows a collapse of the maximum droplet spreading, maximum crater diameter as well as the maximum crater depth. Furthermore, we developed a dynamic model of the mixing behavior between liquid and grains. This model explains the various crater morphologies that we observed.

DISSERTATIONS

-

SCIENTIFIC PUBLICATIONS

-

PROJECT LEADERS

D van der Meer

RESEARCH THEME

Complex dynamics of fluids

PARTICIPANTS

R de Jong, S Zhao

COOPERATIONS

-

FUNDED

NWO

University -

FOM -

STW -

NWO Other 100 %

Industry -

TNO -

GTI -

EU -

Scholarships -

START OF THE PROJECT

2012

INFORMATION

D van der Meer

053 489 2387

d.vandermeer@utwente.nl

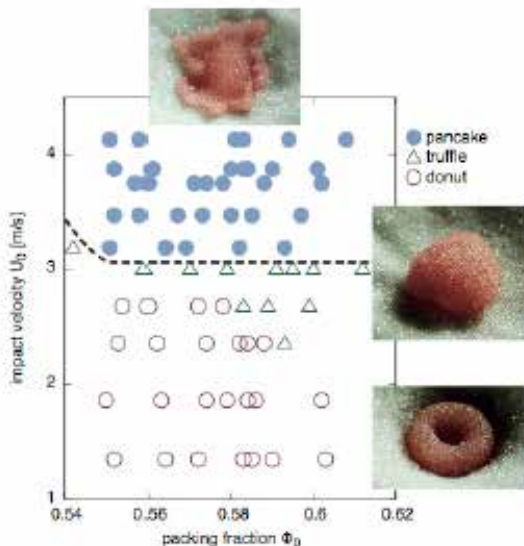

The phase diagram of the crater morphology. The dashed line indicates the boundary between 'donut/truffle' regime and 'pancake' regime.

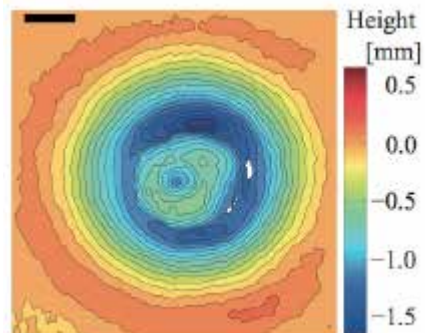

The static, full 3D measurement of the crater after impact with a donut-shaped residue in the centre

VAPOR NANOBUBBLES

PROJECT LEADERS

D Lohse

RESEARCH THEME

Complex dynamics of fluids

PARTICIPANTS

M van der Hoef, S Maheshwari

COOPERATIONS

-

FUNDED

FOM

University -

FOM 100 %

STW -

NWO Other -

Industry -

TNO -

GTI -

EU -

Scholarships -

START OF THE PROJECT

2014

INFORMATION

D Lohse

053 489 8076

d.lohse@utwente.nl

pof.tnw.utwente.nl

PROJECT AIM

It has recently been reported that, when a low-concentration suspension of metal or carbon nanoparticles dispersed in water is illuminated by sun light, water vapor well above 100 C can be produced with an estimated overall energy efficiency of 24%, and only marginal heating of the bulk water. The aim of this project is to reveal the underlying physics of this process, by a combination of molecular dynamics simulations and level set methods for vapor bubbles. The working hypothesis is that vapor bubble stability can only be provided thanks to gas dissolved in the liquid, similarly to what we have been shown theoretically and experimentally for ultrasonically driven vapor bubbles. The ultimate aim is to achieve a satisfactory physical understanding of the process in such a way that it can eventually be optimized.

PROGRESS

As a step-up project for the first half year, the formation of nanodrops on curved surfaces (both convex and concave) has been studied by means of molecular dynamics simulations, where the interparticle interactions are modelled by the Lennard-Jones potential. For quasi-2D system it is found that the contact angle is not affected by the curvature of the surface - in agreement with experimental findings - which means that change of the radius of the droplet with curvature follows from purely geometrical considerations. In addition, preliminary MD simulations have been performed on the stability of nanobubbles of which the contact line is pinned due to chemical heterogeneities of the substrate.

DISSERTATIONS

-

SCIENTIFIC PUBLICATIONS

-

FUNDAMENTAL FLUID DYNAMICS CHALLENGES OF EXTREME ULTRAVIOLET LITHOGRAPHY

PROJECT AIM

A method to generate Extreme Ultraviolet (EUV) light is to ionize liquid tin drops by a laser pulse. The resulting hot plasma emits EUV radiation. Several of the challenges to make this method operational have their origin in contemporary fluid physics. Here, we focus on two of these fluid dynamics challenges. First, we study the deformation and fragmentation of liquid drops upon impact of a laser pulse. Second, we want to define the criteria for the splashing and bouncing of liquid drops on soft (visco-)elastic substrates and the role of heat transfer and liquid solidification during impact.

PROGRESS

We studied the impact of a laser pulse on a liquid drop experimentally and varied two parameters: the focusing of the laser pulse and the laser energy. We are able to explain the results in terms of scaling laws and found a good agreement with numerical simulations. Furthermore, we designed and started building an extended setup that allows us to study the laser impact in a larger parameter space in future work. We tested three hydrogels for drop impact studies with controllable visco-elastic properties for drop impact experiments. Secondly, we performed experiments of drop impact on an elastic membrane covering a liquid pool, where we varied the tension in the membrane. We found the splashing threshold as a function of the tension in the membrane. In 2015 a postdoc and a third PhD student will join our team, to work on drop solidification during impact and multiphase simulations of laser-drop interaction, respectively.

DISSERTATIONS

-

SCIENTIFIC PUBLICATIONS

-

PROJECT LEADERS

H Gelderblom, JH Snoeijer, C Sun, D Lohse

RESEARCH THEME

Complex dynamics of fluids

PARTICIPANTS

MV Gielen, AL Klein, SA Reijers, R de Ruijter, H Gelderblom, JH Snoeijer, C Sun, D Lohse

COOPERATIONS

Villiermaux, Université Aix-Marseille
Lhuissier, Université Paris-Diderot
Toschi, Eindhoven University of Technology, ASML Research

FUNDED

| | |
|--------------|------|
| FOM, ASML | |
| University | - |
| FOM | 50 % |
| STW | - |
| NWO Other | - |
| Industry | 50 % |
| TNO | - |
| GTI | - |
| EU | - |
| Scholarships | - |

START OF THE PROJECT

2013

INFORMATION

H Gelderblom
053 489 5955
h.gelderblom@utwente.nl
<http://stilton.tnw.utwente.nl/people/gelderblom/>



Prof.dr. F Mugele

MISSION

The goal of the PCF group is to understand and control the structure and the mechanical properties of liquids and interfaces on length scales ranging from molecular to submillimeter scales. The activities fall in three main categories: i) nanofluidics, ii) (electro)wetting & microfluidics, iii) soft matter mechanics. Our nanofluidics research focuses on understanding the range of validity of macroscopic continuum physics and in its breakdown upon approaching molecular scales, where physico-chemical aspects become increasingly important. In microfluidics, many properties of fluids, in particular drops, are controlled by interfacial effects. By patterning surfaces and in particular by making use the electrowetting effect we control the shape, the motion, and the generation of microdrops. These processes involve various challenging fundamental issues, such as contact angle hysteresis, the dynamics of contact lines, and hydrodynamic singularities. The soft matter mechanics activities focus on correlations between the internal structure of various types of complex fluids ranging from colloidal suspensions to living cells and their macroscopic viscous and elastic properties.

By improving the physical understanding of fundamental phenomena we contribute to the improvement of various technological processes involving fluid motion on small scales, including oil recovery, immersion lithography, and inkjet printing. This work is frequently carried out in collaboration with industrial partners including BP, Shell, ASML, Océ, Liquavista, sometimes within government sponsored consortia such as FOM-IPPs, sometimes in direct collaboration. A major project on enhanced oil recovery started in late 2009 and became fully operational in 2010. In this context, the group intensified its activities in the area of physical chemistry of liquid-liquid and solid-liquid interfaces. In late 2010, Prof. Mugele obtained a NWO-VICI grant to investigate the properties of superhydrophobic surfaces that are functionalized by electric fields. One major goal of the project is to explore various applications of such smart surfaces for microfluidics, ultrasound detection, and in particular optofluidics.

MODELLING AND SIMULATION OF ELECTROWETTING AND MICROFLUIDICS SYSTEMS

PROJECT AIM

The aim of the project is to provide modelling and numerical simulations for the different microfluidics projects in the PCF group, tailored on the ongoing experimental research in the group. Main focus areas are electrowetting based devices, reversible wetting transitions and the effect of ions absorption on wettability. The tools developed at PCF are also applied to support the electrowetting research carried out at Liquavista. The main contribution in this sense is the development and maintenance of a multiphysics openFoam code to simulate and optimize electrowetting-based pixels.

PROGRESS

I carried out a numerical investigation of the dynamic interaction of sliding sessile droplets with wetting defects, to appear in Phys. Rev. E, 2015 (accepted). I provided modeling support to Bijoyendra Bera's research into the effect of salt adsorption on the wettability of clay surfaces. An article on the topic is currently under review in Scientific Reports. I collaborated to the upcoming (Jun 2015) book "Wetting and evaporation", edited by David Brutin, with a section on amphiphobic surfaces. I collaborated to the optimization of pixel design at Liquavista.

DISSERTATIONS

-

SCIENTIFIC PUBLICATIONS

-

PROJECT LEADERS

F Mugele

RESEARCH THEME

Mathematical and computational methods for fluid flow analysis

PARTICIPANTS

A Cavalli

COOPERATIONS

Liquavista

FUNDED

| | |
|--------------|------|
| University | - |
| FOM | - |
| STW | 50 % |
| NWO Other | - |
| Industry | 50 % |
| TNO | - |
| GTI | - |
| EU | - |
| Scholarships | - |

START OF THE PROJECT

2013

INFORMATION

A Cavalli

053 489 3093

a.cavalli@utwente.nl

www.utwente.nl/tnw/pcf/

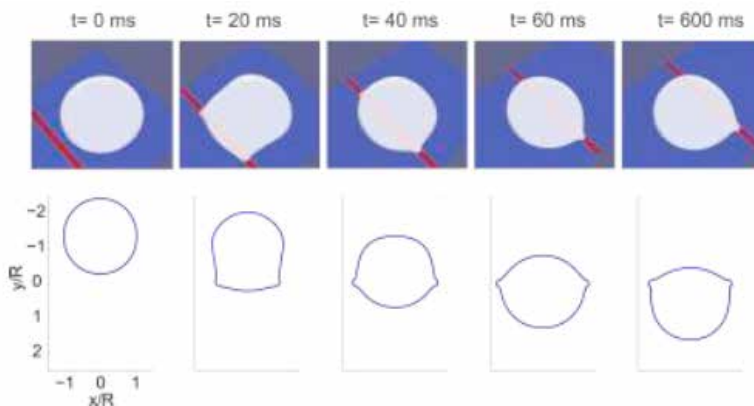

PROJECT LEADERS

F Mugele, M Duits

RESEARCH THEME

Complex dynamics of fluids

PARTICIPANTS

R de Ruiter

COOPERATIONS

BP

FUNDED

BP

| | |
|--------------|-------|
| University | - |
| FOM | - |
| STW | - |
| NWO Other | - |
| Industry | 100 % |
| TNO | - |
| GTI | - |
| EU | - |
| Scholarships | - |

START OF THE PROJECT

2009

INFORMATION

F Mugele

053 489 2106

f.mugele@utwente.nl

www.utwente.nl/tnw/pcf

PROJECT AIM

The goal of the project is to understand the influence of wettability on the efficiency of enhanced oil recovery processes, in particular low salinity water flooding. The project focuses on the consequence of altered wettability on the behavior of drops in microfluidic two-phase flows as they occur in oil reservoirs. Next to chemically induced changes of surface wettability, we make use of electrowetting as a tool to illustrate basic concepts of wetting and morphology transitions in confined systems.

PROGRESS

In the last year of the project, we developed an electrowetting-based platform for the investigation of trapping and release mechanisms of drops in microfluidic two-phase flow systems with heterogeneous channel walls. We investigated the relative strength of viscous drag forces and viscosity-induced pressure gradients on the trapping of drops by channel heterogeneities. Moreover, we found that even small amounts of contact angle hysteresis can have a profound on the stability of wetting morphologies in complex geometries, such as model pore throats. On an applied note, our experiments demonstrated the benefits of hybrid electrowetting-two phase flow microfluidic systems for Lab-on-a-Chip systems. Our paper was featured on the cover page of the journal Lab-on-a-Chip in January 2014.

DISSERTATIONS

1. Riëlle de Ruiter: Manipulation of drops with electrowetting, from morphological transitions to microfluidics; March 26, 2014.

SCIENTIFIC PUBLICATIONS

1. Riëlle de Ruiter, Arjen M. Pit, Vitor Martins de Oliveira, Michel H.G. Duits, Dirk van den Ende and Frieder Mugele: Electrostatic potential wells for manipulations of drops flowing through microchannels; Lab on a Chip 14 (2014) 883--891.

ELECTRICALLY DRIVEN OPTOFLUIDIC LENSES

PROJECT AIM

The aim of the project is to demonstrate the functionality of liquid-liquid interface as a tunable adaptive fluidic lens, modulated electrostatically and regulated hydrostatically by applying electric field to a drop entrapped in an aperture. The objective is to suppress spherical aberration by simultaneously applying the electric field and regulating the backpressure. Further analysis includes optical characterization and demonstration of aberration controlling ability of lens by optical imaging, corroborated with optical simulations on Zemax.

PROGRESS

1. We fabricated the robust aspherical lens device. This had happened after 3-4 adaptations. The device consists of Teflon coated bottom ITO substrate for electrowetting, aperture plate and top electrode. Electric field is applied between the top electrode and water drop, entrapped in the aperture, for inducing asphericity. In the current device, backpressure is modulated by Electrowetting rather than our previous approach by hydrostatic pressure.
2. Optical characterization of aspherical lens: Aspherical lenses have considerably reduced spherical aberration, compared to spherical lenses. The objective is to characterize and quantify the same by Shack-Hartmann wave front sensor (SHWS).
3. Optical simulations are performed on the Zemax to study the effect of top electrode on spherical aberration.

DISSERTATIONS

-

SCIENTIFIC PUBLICATIONS

1. Kartikeya Mishra, Chandra Murade, Bruno Carreel, Ivo Roghair, Jung Min Oh, Gor Manukyan, Dirk van den Ende, and Frieder Mugele: Optofluidic lens with tunable focal length and asphericity; Sci. Rep. 4 (2014) 6378: 1--4.

PROJECT LEADERS

F Mugele

RESEARCH THEME

Complex dynamics of fluids

PARTICIPANTS

K Mishra, HTM van den Ende,
F Mugele

COOPERATIONS

-

FUNDED

| | |
|---------------|-------|
| STW, Industry | - |
| University | - |
| FOM | - |
| STW | 100 % |
| NWO Other | - |
| Industry | - |
| TNO | - |
| GTI | - |
| EU | - |
| Scholarships | - |

START OF THE PROJECT

2011

INFORMATION

K Mishra
053 489 3134
k.mishra@utwente.nl
www.utwente.nl/
tnw/pcf/people/phd_students/mishra.
docx/

PROJECT LEADERS

F Mugele, HTM van den Ende

RESEARCH THEME

Complex dynamics of fluids

PARTICIPANTS

J de Ruiter

COOPERATIONS

HIPRINS consortium

FUNDED

Dutch Ministry of Economic Affairs, Agriculture and Innovation, the provinces Overijssel, Limburg, and Noord-Brabant, and cityregion Eindhoven (SRE)

University -

FOM -

STW -

NWO Other -

Industry -

TNO -

GTI -

EU 100 %

Scholarships -

START OF THE PROJECT

2009

INFORMATION

F Mugele

053 489 2106

f.mugele@utwente.nl

www.utwente.nl/tnw/pcf

PROJECT AIM

the goal of the project was to provide fundamental understanding of the impact dynamics and spreading of drops of complex fluids onto solid surfaces. Specific points of interest include the effect of ambient air on the impact process as well as the effect of surface topography.

PROGRESS

We applied our recently developed method of dual wavelength interferometry to understand the complex effect of ambient air on the impact of drops onto solid surfaces. The experiments yielded a detailed description of the effect of topographic pillars, ridges, and edges of variable geometric dimension on the formation of solid-liquid contact formation. The shape of a lubricating air film could be described with a thickness resolution of 10nm, lateral resolution of 3 μ m, and time resolution of 50 μ s. Moreover under certain impact conditions the droplets repeatedly bounce even on wetting flat substrates. Our observations have been published on line in Nature Physics, November 2014.

DISSERTATIONS

1. Jolet de Ruiter: An airbag for drops: high speed interferometry studies of air film lubrication in drop impact; march 26, 2014.

SCIENTIFIC PUBLICATIONS

-

EFFECTS OF SHEAR AND WALLS ON THE DIFFUSION OF COLLOIDS IN MICROCHANNELS

PROJECT AIM

Colloidal diffusion in flow specially for concentrated systems is less explored. Previous investigations, mostly with non-Brownian suspension, suggest that the diffusivity enhances due to shear. Simultaneously, presence of a flat wall reduces particle mobility. But the interplay between shear and wall effect on particle diffusion is not addressed. Main focus is to study the effect of shear on Brownian diffusion and also how does the combination of shear and wall act together on colloidal diffusion?

PROGRESS

Microchannels with rectangular cross-section are used to perform experiments. Motion of colloids for different concentrations and flow rates are scanned using Confocal Laser Scanning Microscope. Using 2D particle tracking method, velocity, diffusivity of colloids at different shear rates are measured accurately. It is observed that convection corrected diffusivity for dilute suspension is independent of local shear rate. In contrast, for concentrated systems, particle diffusivity enhances anisotropically in presence of shear. But for both the concentrations, wall has a diminishing effect on diffusion which strongly suppresses shear effect closer to the wall. Two drafts are under preparation related to this study.

DISSERTATIONS

-

SCIENTIFIC PUBLICATIONS

-

PROJECT LEADERS

F Mugele, MHG Duits

RESEARCH THEME

Complex dynamics of fluids

PARTICIPANTS

S Ghosh, MHG Duits

COOPERATIONS

-

FUNDED

| | |
|--------------|-------|
| NWO | |
| University | - |
| FOM | - |
| STW | - |
| NWO Other | 100 % |
| Industry | - |
| TNO | - |
| GTI | - |
| EU | - |
| Scholarships | - |

START OF THE PROJECT

2011

INFORMATION

MHG Duits
053 489 3097
m.h.g.duits@utwente.nl
www.utwente.nl/tnw/pcf/people/scientific_staff/MichelDuits/

CELL-SPREAD

PROJECT LEADERS

LWMM Terstappen, F Mugele,
MHG Duits

RESEARCH THEME

Complex dynamics of fluids

PARTICIPANTS

AM Pit, I Stojanović

COOPERATIONS

-

FUNDED

STW, Micronit, IBIS, Ssens, Sanquin,
Merus

University -

FOM -

STW 83 %

NWO Other -

Industry 17 %

TNO -

GTI -

EU -

Scholarships -

START OF THE PROJECT

2011

INFORMATION

AM Pit

053 489 3093

a.m.pit@utwente.nl

PROJECT AIM

To detect, per patient, the presence and affinity of therapeutic targets on a single circulating tumor cells (CTC). Digital microfluidics is used to create drops containing 1 CTC and guide the drop over a gold substrate patched with specific ligands targeting specific molecules. Using surface plasmon resonance imaging (SPRi) the binding processes of cell excreted proteins are quantified, effectively characterizing the cancer cell. This would allow for a quick diagnostic tool to administer the right type of medicine.

PROGRESS

An analytical, capacitive model has been developed, which accurately describes the electrostatic forces exerted on water droplets in oil by the electrodes incorporated directly below the microfluidic channel. Experimentally, a three-electrode Y-geometry is used to actively sort water drops at 1200 drops per second. Experiments showed it was not only possible to sort conductive drops, but also non-conductive drops with a high relative permittivity (DEP). Numerical simulations were performed, which match very well with the analytic model and experiments. The simulations show that indeed the electric fields for conductive and dielectric drops are similar – most of the applied potential drops across the insulating layer. However, DEP only works in certain size ranges where the drop capacitance is much larger than the insulating layer capacitance. Thus, besides a large permittivity contrast, also a relatively large dielectric thickness and small drop radius are required.

DISSERTATIONS

-

SCIENTIFIC PUBLICATIONS

1. R. de Ruiter, A.M. Pit, et al. Electrostatic potential wells for on-demand drop manipulation in microchannels. Lab on a Chip, doi:10.1039/c3lc51121a (2014).

Lab on a chip cover by A.M. Pit showing the ideal, future chip. The chip contains a sorting electrode geometry which sorts drops containing a cell from empty drops. Cell-containing drops are then guided with electrodes to arrays of drop traps. Here the cells can be analyzed by measuring the ligand-ligand interactions at the substrate by surface plasmon resonance imaging.

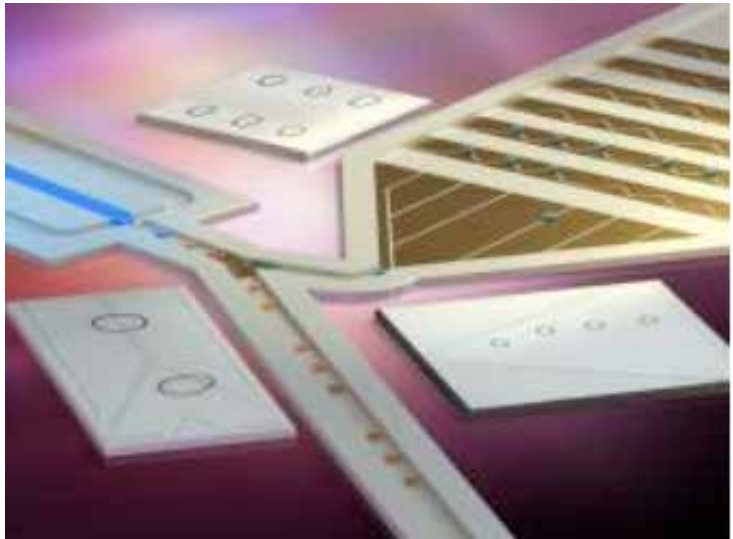



Prof.dr.ir. RGH Lammertink

Research within the Soft matter, Fluidics and Interfaces group is directed at interfacial phenomena and processes that are relevant for mass and heat transport. We wish to study and exploit fundamental principles where fluid flow encounters structures on a sub-millimeter length scale. Current topics of interest are:

ADVANCED MICROREACTORS

The fabrication and operation of dedicated microreactors, amendable to scaling are investigated. Multiphase reactor systems that incorporate membrane functionality to stabilize interfaces and perform separations are developed.

SOFT INTERFACES

Liquid-liquid and gas-liquid interfaces are crucial in many chemical processes. Interfacial phenomena, including wetting behavior, interfacial tension (gradients), interfacial curvature, are studied to gain understanding in related transport processes near these interfaces.

MICRO- AND NANOFUIDICS

This topic addresses liquid flow in confined geometries. Its relation to mass and energy transport are studied in both experimental and numerical ways. Special attention is given to boundary layer and concentration polarization phenomena.

PROJECT AIM

The growth of bacteria in water treatment membrane units is considered as one of the most prominent challenges this technology faces. Although biofouling is the most severe form of fouling for membrane based water purification processes, no generally accepted mechanism is present. There has been significant effort in elucidating the formation and growth of biofilms inside membrane purification units. In recent microfluidic experiments, it was hypothesized that the biofilm growth is associated with subtle secondary flow patterns that exist in square shaped channels. Furthermore, extensive fluid dynamics simulations indicated that the local substrate and oxygen concentrations in biofilm covered flow channels govern the biofilm growth. Here, we seek to perform experimental investigations on the microscopic scale concerning convection and concentration profiling.

PROGRESS

Regarding the experimental setup, different microfluidic channel designs were tested, the main issue was how much fouling could they accommodate before blocking. In addition, different connections, fittings, tubing and flow meters were tested. This resulted in a working setup that can run continuously under fouling conditions for about a week. Focus has been on the application of Particle Tracking Microrheology to investigate the stiffness of the biofilm (hydrogel) under different flow conditions. Initial results are promising. However, reproducibility due to the heterogeneity of the biofilm remains an issue. The current focus is on optimizing the experimental protocol.

DISSERTATIONS

-

SCIENTIFIC PUBLICATIONS

-

PROJECT LEADERS

RGH Lammertink

RESEARCH THEME

Complex dynamics of fluids

PARTICIPANTS

El Tayeb el Obied, Khalid

COOPERATIONS

-

FUNDED

| | |
|--------------|-------|
| ERC | |
| University | - |
| FOM | - |
| STW | - |
| NWO Other | - |
| Industry | - |
| TNO | - |
| GTI | - |
| EU | 100 % |
| Scholarships | - |

START OF THE PROJECT

2013

INFORMATION

RGH Lammertink

053 489 2063

r.g.h.lammertink@utwente.nl

[www.utwente.nl/tnw/sfi/people/staff/](http://www.utwente.nl/tnw/sfi/people/staff/lammertink)

lammertink

PROJECT LEADERS

RGH Lammertink

RESEARCH THEME

Complex dynamics of fluids

PARTICIPANTS

S Haase

COOPERATIONS

S. Jonathan Chapman (Oxford University), Jens Harting (TU/e, University of Twente)

FUNDED

| | |
|--------------|-------|
| ERC | |
| University | - |
| FOM | - |
| STW | - |
| NWO Other | - |
| Industry | - |
| TNO | - |
| GTI | - |
| EU | 100 % |
| Scholarships | - |

START OF THE PROJECT

2012

INFORMATION

RGH Lammertink
053 489 2063
r.g.h.lammertink@utwente.nl
www.utwente.nl/tnw/sfi/people/staff/
lammertink

PROJECT AIM

The focus of this ERC-project lies on interfacial transport phenomena that occur in e.g. membrane processes, and in particular on those phenomena that often form a limiting factor in these processes such as concentration polarization. By investigation of these phenomena in well-defined systems, in microfluidic devices for example, we aim to acquire a deeper and more fundamental understanding of interfacial transport phenomena. The project of Sander Haase focuses on the hydrodynamical aspects of interfacial transport.

PROGRESS

In the past year, research has been focusing on (1) the Graetz-Nusselt problem for wall slip and (2) momentum transport of viscoelastic liquids over a bubble mattress. Regarding the first topic, we have numerically and analytically connected the two solutions of the classical Graetz-Nusselt forced-convection problem by extending this problem to finite, homogeneous wall slip. This has resulted in a paper (in 2015). This study is to be completed by also considering heterogeneous wall slip. An experimental study has been dedicated to the transport of shear-thinning xanthan gum solutions over a bubble mattress. The results appear to be promising, but further research is necessary. This study will be complemented by numerical simulations, which will provide more insight into the relationship between viscoelastic behavior and wall slip.

DISSERTATIONS

-

SCIENTIFIC PUBLICATIONS

-

SURFACE HETEROGENEITY AND INTERFACIAL TRANSPORT

PROJECT AIM

Small-scale surface structures, both geometrically as well as chemically, can potentially influence the fluid dynamics and hence the mass transport on a microscopic scale. There is a need to understand these influences in great detail on the nano- and microscopic level, in order to couple them to the largest scales in the flow. The aim is to study catalytic surface heterogeneity with respect to interfacial transport phenomena. To obtain information, the fluid dynamics (momentum transport) and concentration profiles (mass transport) will be experimentally probed on a length scale comparable to the boundary layer.

PROGRESS

The reduction of levulinic acid to γ -valerolactone will be first explored via the catalytic transfer hydrogenation reaction, where the hydrogen donor is a secondary alcohol. The advantage is the use of non-precious metal heterogeneous catalysts. Zirconium oxide was chosen as the first candidate. The catalyst was deposited by reactive magnetron sputtering with a zirconium target using a dc power source. High resolution scanning electron microscopy revealed a nonporous film with a high roughness. The elemental stoichiometry of the metal oxide was investigated using Energy dispersive X-ray spectroscopy. The chemical composition was also confirmed by X-Ray Photoelectron Spectroscopy. The thickness, roughness as well as optical constants could be determined by Spectroscopic Ellipsometry. X-ray Diffraction was used to investigate the degree of crystallinity and detect the crystalline phases. The orientation of the crystallites was visualized by TEM.

DISSERTATIONS

-

SCIENTIFIC PUBLICATIONS

1. Visan, A., Rafieian, D., Ogieglo, W. & Lammertink, R. G. H. Modeling intrinsic kinetics in immobilized photocatalytic microreactors. *Appl. Catal. B Environ.* 150-151, 93–100 (2014).

PROJECTLEADERS

RGH Lammertink

RESEARCHTHEME

Complex dynamics of fluids

PARTICIPANTS

A Visan

COOPERATIONS

MCEC-UT-2-3

FUNDED

| | |
|--------------|-------|
| University | - |
| FOM | - |
| STW | - |
| NWO Other | 100 % |
| Industry | - |
| TNO | - |
| GTI | - |
| EU | - |
| Scholarships | - |

START OF THE PROJECT

2014

INFORMATION

RGH Lammertink

053 489 2063

r.g.h.lammertink@utwente.nl

www.utwente.nl/tnw/sfi/people/staff/lammertink

PROJECT LEADERS

RGH Lammertink

RESEARCH THEME

Complex dynamics of fluids

PARTICIPANTS

J Wood

COOPERATIONS

-

FUNDED

ERC

University -

FOM -

STW -

NWO Other -

Industry -

TNO -

GTI -

EU 100 %

Scholarships -

START OF THE PROJECT

2014

INFORMATION

RGH Lammertink

053 489 2063

r.g.h.lammertink@utwente.nl

www.utwente.nl/tnw/sfi/people/staff/

lammertink

PROJECT AIM

The primary aim is the investigation of ion concentration polarization and ion-selective interfaces at the microscale, focusing on studying ion-selective nanochannels using AC impedance spectroscopy and on the use of novel nanochannel networks formed using colloidal assemblies for ion-selectivity. Combining measurements (μ PIV for the fluid flow) with ion concentration profiles and electric field distributions from simulations will elucidate the interaction between fluid flow, ion advection, diffusion, etc.. Secondly, the use of three-dimensional nanochannel networks formed from colloidal assemblies (colloidal crystals) will be investigated and analyzed using the same methodology.

PROGRESS

Currently, the microfabrication of new chips for testing colloidal crystal nanochannel networks is underway, simulation frameworks relating to predicting/understanding experimentally fabricated devices (colloidal crystals and "conventional" nanochannel arrays) have been established and the impedance analyzer system is being calibrated for on-chip measurement to incorporate AC impedance measurements into existing DC conductance and particle-image velocimetry techniques.

DISSERTATIONS

-

SCIENTIFIC PUBLICATIONS

-

PROJECT AIM

The proposed experiments include the measurement of fluid flow and ion concentration, both at high precision near a membrane. In electro dialysis, an ion selective membrane is used through which ion transport is driven by an external electric field. Upon increase of the potential, a limiting and overlimiting current regime are observed. The origin of this regime is today still a topic of discussion. Under severe concentration polarization conditions, the occurrence of electroconvection phenomena is predicted. We intend to approach this problem by using controlled microfluidic experiments near ion selective materials.

PROGRESS

Design and fabrication of microfluidic chips containing nanochannels as the charge-selective interface. Experiments on concentration polarization, including DC electrical characterization, fluorescence microscopy to visualize ion concentration. Simultaneous IV-sweeps with visualization using different imposed flow fields. Chronoamperometry measurements with visualization to see build-up of the concentration polarization layer. Preliminary μ PIV measurements for flow field visualization near the charge-selective interface.

DISSERTATIONS

-

SCIENTIFIC PUBLICATIONS

-

PROJECT LEADERS

RGH Lammertink

RESEARCH THEME

Complex dynamics of fluids

PARTICIPANTS

A Benneker

COOPERATIONS

-

FUNDED

ERC

University -

FOM -

STW -

NWO Other -

Industry -

TNO -

GTI -

EU 100 %

Scholarships -

START OF THE PROJECT

2013

INFORMATION

RGH Lammertink

053 489 2063

r.g.h.lammertink@utwente.nl

[www.utwente.nl/tnw/sfi/people/staff/](http://www.utwente.nl/tnw/sfi/people/staff/lammertink)

lammertink



Prof.dr.ir. EWC van Groesen

In our group AAMP we study natural phenomena or help to design and improve technical apparatus or processes. We investigate the propagation of surface waves on a layer of fluid, the shock propagation caused by volcano eruptions through the earth, and the way how light gets reflected and transmitted through different materials.

We study these aspects with a set of suitable mathematical techniques that we extend and improve constantly. Our understanding of the phenomena is reflected in the mathematical models, which are updated and improved with increased understanding from theoretical investigations and simulations. Except for their mathematical structure with intrinsic beauty, our investigations are often 'useful': for hydrodynamic laboratories we advise how to generate the wave fields that they want to produce in their tanks to test ships in realistic situations, the calculations of seismic events may lead to an understanding which earth quakes give rise to large tsunamis, the design of optical devices with nano-scale structures helps to advance telecommunication, etc.

The topics mentioned above are very diverse in their appearance, and cover length scales ranging from 10^{-9} till 10^7 meter. The beauty of the mathematical descriptions is that they are actually quite similar: the major physical process is the evolution of waves, or an abstraction of it. Special properties that depend on the application are reflected in the mathematical structure of the wave equations that are at the basis of the models. For instance, energy or momentum conservation corresponds to symmetries in the mathematical formulations. Specific methods that we use include variational methods, which exploit the remarkable fact that often a certain optimality property can be found in the phenomenon. Except for theoretical methods, often supported with computer algebraic calculations, regularly we design larger or smaller simulation tools of a numerical nature.

For the design of these numerical schemes we aim to keep the special properties of our theoretical models as well, leading to consistent finite dimensional version of the infinite dimensional models.

The research in water waves contains various topics. Characteristic is that for irrotational flows we approach the problems in a unified consistent modelling way. This is based on the fact that upon neglecting dissipation, the full free surface equations have a basic variational structure (Luke, 1967), with the free surface equations described by a Hamiltonian system (Zakharov 1968, Broer 1974). In our modelling of specific wave fields, we exploit this structure by finding approximations of the kinetic energy part of the Hamiltonian. This is used for approximate models described by pde's like the shallow water equations, Boussinesq-, KdV and NLS-type of equations.

For numerical simulations, this structure is exploited to find consistent discretizations by variational restriction: the functionals defined on infinite dimensional spaces are restricted to finite dimensional subspaces, which may be high dimensional but may also be much more restricted by including essential properties of the phenomenon in the description, depending on the specific cases.

Within the basic approach, we include various active or passive boundary conditions, depending on the application (to generate waves by wave flaps for hydrodynamic laboratories, or bottom motions for seismic applications), or to allow a reflection-free description for calculations on numerical artificial windows. Locally, the activities are grouped in the projects Math Modelling and consistent Numerical Simulations, Free flows and Extreme Waves, Coastal Waves, and Seismic generation of waves.

WAVE MODELLING AND SIMULATION FOR OCEAN AND COASTAL ENGINEERING

PROJECT AIM

In various subprojects the variational structure of inviscid fluid dynamics is used to derive accurate and efficient numerical implementations of Boussinesq-type of equations. Hamiltonian variational wave models with exact dispersion are obtained with a spatial-spectral implementation, and with a problem-dependent optimal dispersive FEM implementation. Applications deal with laboratory, coastal and oceanic waves, including harbour waves, extreme (freak) waves, and tsunamis.

PROGRESS

Supported by comparison with experiments, we improved the FE-Variational Boussinesq Model for harbour simulations with short crested wave influx including calculation of infra-gravity waves. For the spatial-spectral AB model we considered moving shore lines for run-up with embedded methods; wave breaking based on a kinematic breaking criterion showed good performance for spilling breaking waves during run-up and over bars and for the dam break problem. Run-up was also modelled using a mixed numerical-analytic method through an effective boundary condition. An accurate method was derived to determine the significant wave height of sea states from radar images of (multi-modal) seas.

DISSERTATIONS

1. Wenny Kristina, Effective coastal boundary conditions for tsunami simulations (NWO-ALW), 2 October 2014.

SCIENTIFIC PUBLICATIONS

1. W. Kristina, O. Bokhove & E. van Groesen, Effective coastal boundary conditions for tsunami wave run-up over sloping bathymetry, *Nonlin.Processes GeoPhys*, 21(2014) 987-1005.
2. Lie S Liam, D. Adytia & E. van Groesen, Embedded wave generation for dispersive surface wave models, *Ocean Engineering* 80(2014) 73-83.
3. R. Kurnia & E. van Groesen, High Order Hamiltonian Water Wave Models with Wave-Breaking Mechanism, *Coastal Engineering* 93(2014) 55-70.
4. R. Kurnia & E. van Groesen, Spatial-spectral Hamiltonian Boussinesq wave simulations, *Advances in computational and Experimental marine hydrodynamics*, VOL. 2 Conference Proceedings, 2014, pp. 19-24, ISBN: 978-93-80689-22-7.

PROJECT LEADERS

EWC van Groesen

RESEARCH THEME

Mathematical and computational methods for fluid flow analysis

PARTICIPANTS

R Kurnia, M Hafizh, D Adytia, W Kristina, AP Wijaya, Andonowati (LabMath-Indonesia & ITB)

COOPERATIONS

LabMath-Indonesia, Bandung Indonesia, MARIN Wageningen, TUD Ship hydromechanics & structures

FUNDED

| | |
|-----------------------|------|
| UT, STW, NWO-ALW, IOP | |
| University | 30 % |
| FOM | - |
| STW | 30 % |
| NWO Other | 10 % |
| Industry | 10 % |
| TNO | - |
| GTI | 10 % |
| EU | - |
| Scholarships | 10 % |

START OF THE PROJECT

2012

INFORMATION

E van Groesen
053 489 3413
groesen@math.utwente.nl



Prof.dr.ir. JWW van der Vegt



Prof.dr.ir. O Bokhove

The research in the Mathematics of Computational Science group in the Department of Applied Mathematics of the University of Twente concentrates on two main topics:

- ♦ The development, analysis and application of numerical algorithms for the (adaptive) solution of partial differential equations for problems originating from the physical and technical sciences, in particular (discontinuous Galerkin) finite element methods.
- ♦ Mathematical modeling of complex physical problems to make them accessible for computation, in particular for turbulence and geophysical problems. In order to support these activities a significant research effort is directed towards the development of hpGEM, an object oriented toolkit for finite element methods, written in C++, and suitable for high performance parallel computers. Important applications are in the fields of gas dynamics, wet chemical etching of microstructures, fluid structure interaction, two phase flows both dispersed and with free surfaces, water waves, large eddy simulation of turbulent flows, geophysical flows and computational electromagnetics. Many of these projects are conducted in close collaboration with groups in physics and chemical technology, large technological research institutes (NLR, MARIN, WL Delft Hydraulics, KNMI), and industry (DSM, AKZO and Shell).

The research is conducted in the research institute IMPACT and the research in two-phase flows is part of the UT spearhead program “Dispersed multiphase flows”. The NACM group participates in the 3TU Center of Excellence for Multiscale Phenomena.

COMPLEX WAVE-CURRENT INTERACTIONS IN A NUMERICAL WAVE TANK

PROJECT AIM

Our aim is to develop novel space-time (dis)continuous Galerkin methods based on variational principles to model nonlinear free-surface waves. The advantage is that the resulting numerical discretization will preserve energy, phase-space structure and variational structure. Further, the numerical scheme will show no decay in amplitude and will be suitable for long time simulations. Numerical results will be compared with wave tank data of the Maritime Research Institute Netherlands (MARIN).

PROGRESS

A novel third order accurate symplectic time integrator was developed and tested on nonlinear water waves in a model basin. A key feature of this method is that it is derived using a variational framework. This approach nicely combines with the use of Luke's variational principle for nonlinear water waves, which we have used in the development of an accurate finite element method to compute nonlinear potential flow water waves.

DISSERTATIONS

1. E. Gagarina, Variational Approaches To Water Wave Simulations. PhD thesis, Univ. of Twente, Thesis defence 3-10-2014, Promotors Prof.dr.ir J.J.W. van der Vegt, and Prof.dr.ir. O. Bokhove.
2. W. Kristina, Effective Coastal Boundary Conditions for Tsunami Simulations. PhD thesis, Univ. of Twente, Thesis defence 2-10-2014, Promotors Prof.dr.ir E.W.C. van Groesen, and Prof.dr.ir. O. Bokhove.

SCIENTIFIC PUBLICATIONS

1. E. Gagarina, V.R. Ambati, J.J.W. van der Vegt, and O. Bokhove, (2014), Variational space-time (dis)continuous Galerkin method for nonlinear free surface water waves. *Journal of Computational Physics*, 275, pp. 459-483.
2. A.R. Thornton, A.J. van der Horn, E. Gagarina, W. Zweers, R.M. van der Meer, and O. Bokhove, (2014), Hele-Shaw beach creation by breaking waves: a mathematics-inspired experiment. *Environmental Fluid Mechanics*, 14(5), pp. 1123-1145.
3. O. Bokhove, A.J. van der Horn, R.M. van der Meer, A.R. Thornton, and W. Zweers, (2014), On wave-driven "shingle" beach dynamics in a table-top Hele-Shaw cell. In: *Proceedings of 34th Conference on Coastal Engineering 2014*, 15-20 Jun 2014, Seoul, Korea. sediment.41. *Coastal Engineering (34)*. Coastal Engineering Research Council.
4. W. Kristina, O. Bokhove, E.W.C. van Groesen, (2014), Effective coastal boundary conditions for tsunami wave run-up over sloping bathymetry. *Nonlinear Processes in Geophysics*, 21(5), pp. 987-1005.

PROJECT LEADERS

JJW van der Vegt, O Bokhove

RESEARCH THEME

Mathematical and computational methods for fluid flow analysis

PARTICIPANTS

S Nurijanyan, E Gagarina,
VR Ambati

COOPERATIONS

A Thornton

FUNDED

STW/NWO
University -
FOM -
STW 100 %
NWO Other -
Industry -
TNO -
GTI -
EU -
Scholarships -

START OF THE PROJECT

2008

INFORMATION

o.bokhove@utwente.nl
www.math.utwente.nl/~bokhove/

j.j.w.vandervegt@utwente.nl
<http://wwwhome.math.utwente.nl/~vegtjjw/>

e.gagarina@utwente.nl
www.math.utwente.nl/~gagarinae/

PROJECT LEADERS

JJW van der Vegt, S Luding
A R Thornton

RESEARCH THEME

Mathematical and computational
methods for fluid flow analysis

PARTICIPANTS

DR Tunuguntla

COOPERATIONS

T Weinhart

FUNDED

| | |
|--------------|-------|
| STW | |
| University | - |
| FOM | - |
| STW | 100 % |
| NWO Other | - |
| Industry | - |
| TNO | - |
| GTI | - |
| EU | - |
| Scholarships | - |

START OF THE PROJECT

2011

INFORMATION

DR Tunuguntla
053 489 3373
D.R.Tunuguntla@utwente.nl

PROJECT AIM

The primary goal of the project is to investigate dry polydispersed, both in size and density, granular flows over inclined channels, including segregation phenomena. For this purpose, we develop a macro-scale continuum Discontinuous Galerkin Finite Element Method (DGFEM) granular flow model and couple it to a micro-scale discrete particle model (DPM). This project also runs in close collaboration with an industrial partner, Tata Steel.

PROGRESS

A highly effective averaging technique called coarse graining was extended to bidisperse mixtures varying both in size and density. Given the particle data such as positions, velocities and forces acting on them, one can extract the macroscopic field variables like density, velocity and stresses. The fields are no approximations as they locally satisfy the mass and momentum balance equations. By this micro-macro mapping, one could use DPMs to develop and calibrate the continuum models.

DISSERTATIONS

-

SCIENTIFIC PUBLICATIONS

1. Tunuguntla D. R.; Bokhove, O. and Thornton A. R., (2014), A mixture theory for size and density segregation in shallow granular free-surface flows, *Journal of Fluid Mechanics*, 749, 99-112.

Bi-disperse mixture flows flowing over a rough inclined channel.

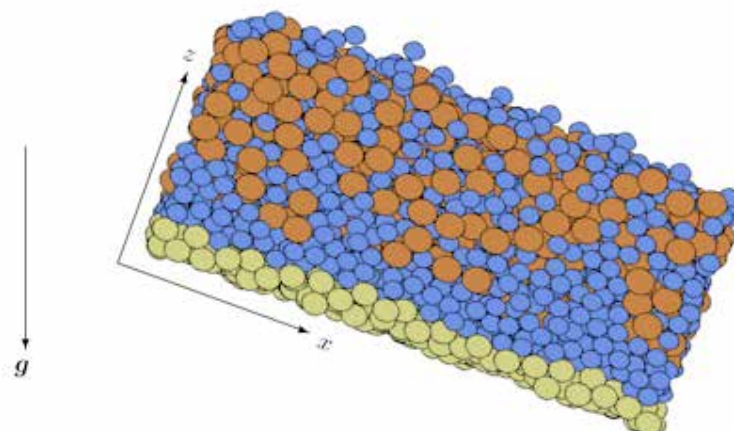

LOCAL DISCONTINUOUS GALERKIN METHODS FOR PHASE TRANSITION

PROJECT AIM

The numerical simulation of phase transition requires an accurate description of the physical phenomena at the interface between the different phases. The equations modeling phase transitions are, however, a hyperbolic-elliptic system for which standard numerical methods are not suitable. In this project, a local discontinuous Galerkin (LDG) method, enjoying conservative, stable and highly accurate properties, is considered to solve the equations describing phase transitions. Due to its local element wise discretization, the LDG method is well suited for local refinement, which is important to capture the interface accurately.

PROGRESS

A paper discussing the analysis and solution of a hyperbolic-elliptic system modeling phase transitions in solids and fluids by a local discontinuous Galerkin(LDG) method was published in the Journal of Scientific Computing. We also solved the (non-)isothermal Navier-Stokes-Korteweg (NSK) equations modeling phase transition between a vapor and a liquid with a LDG method. The LDG method for the NSK equations was implemented for 1D and 2D problems. In order to deal with the severe time-step restriction due to the nonlinear third order derivatives, we use a diagonally implicit Runge-Kutta time method. A paper discussing this research was submitted to Journal of Computing Physics. Currently we study mesh adaption for two-dimensional problems to improve computational efficiency and the accuracy in capturing the interface. Satisfactory results have been obtained for mesh refinement, and the extension to mesh coarsening is in progress.

DISSERTATIONS

-

SCIENTIFIC PUBLICATIONS

1. L. Tian, Y. Xu, J.G.M. Kuerten and J.J.W. Van der Vegt, A local discontinuous Galerkin method for the propagation of phase transition in solids and fluids, Journal of Scientific Computing 59 (2014), pp.688-720.

PROJECT LEADERS

JJW van der Vegt

RESEARCH THEME

Mathematical and computational methods for fluid flow analysis

PARTICIPANTS

L Tian, JJW van der Vegt, Y Xu (USTC, China), JGM Kuerten

COOPERATIONS

University of Science and Technology of China (USTC), Hefei, China

FUNDED

CSC Fellowship China
University -
FOM -
STW -
NWO Other -
Industry -
TNO -
GTI -
EU -
Scholarships 100 %

START OF THE PROJECT

2011

INFORMATION

L Tian

L.Tian@utwente.nl

PROJECT LEADERS

JJW van der Vegt

RESEARCH THEME

Mathematical and computational methods for fluid flow analysis

PARTICIPANTS

F Brink, JJW van der Vegt

COOPERATIONS

R.H.M. Huijsmans, TU Delft,
Damen Ship Yards, MARIN, Royal
Netherlands Navy, Bureau Veritas,
Lloyds Register, Royal Netherlands
Rescue Organization

FUNDED

| | |
|--------------|------|
| STW | |
| University | - |
| FOM | - |
| STW | 66 % |
| NWO Other | - |
| Industry | 33 % |
| TNO | - |
| GTI | - |
| EU | - |
| Scholarships | - |

START OF THE PROJECT

2014

INFORMATION

JJW van der Vegt

j.j.w.vandervegt@utwente.nl

wwwhome.math.utwente.nl/~vegtjjw/

PROJECT AIM

This project aims at developing new simulation tools to compute the dynamics of fast ships and the surrounding wave field. The waves are modeled using the potential flow water wave equation. A key element in the development of the numerical algorithm is the preservation of the underlying Hamiltonian structure after numerical discretization using a finite element method. In an earlier research project by Gagarina et al. this was accomplished for waves in a model basin with a wave maker. The challenge is now to include also a ship and the induced wave motion in the simulation model.

PROGRESS

An initial parallel implementation of the finite element discretization for the computation of potential flow water waves has been made using the finite element toolkit hpGEM. At this moment a ship is not included yet. Test results for a model basin with wave maker compare well with earlier results of Gagarina et al. and also with experiments conducted by MARIN. The next steps in the development are the incorporation of a general mesh deformation algorithm and a ship hull.

DISSERTATIONS

-

SCIENTIFIC PUBLICATIONS

-

DISCONTINUOUS GALERKIN METHOD FOR INKJET FLOW SIMULATIONS

PROJECT AIM

Inkjet flow simulations require the accurate computation of the free surface at the liquid-air interface, and in particular the break-up into small droplets and the effect of air on the droplet motion. In order to achieve these goals a new discontinuous Galerkin finite element discretization is being developed that can accurately compute the droplet formation and droplet motion. The use of a discontinuous Galerkin method in this project is motivated by the possibility to obtain higher order accurate numerical discretizations on solution adaptive locally refined meshes, which opens new ways to accurately simulate inkjet flows.

PROGRESS

The higher order local discontinuous Galerkin method to simulate inkjet printing was further extended to improve its efficiency and accuracy. For this purpose several higher order diagonally implicit Runge-Kutta methods were implemented and tested. In order to deal with singularities occurring at the breakup of the inkjet into droplets a novel velocity mollifier technique and a new approach to ensure positivity of the area were introduced. This method replaces the commonly used limiters, which do not combine well with an implicit time integration method and severely reduce accuracy at steep gradients. In order to solve the highly nonlinear equations resulting from the implicit time integration methods a new semi-smooth Newton method was tested and implemented. This model is currently extensively tested on a number of inkjet problems, including breakup into droplets.

DISSERTATIONS

-

SCIENTIFIC PUBLICATIONS

-

PROJECT LEADERS

JJW van der Vegt

RESEARCH THEME

Mathematical and computational methods for fluid flow analysis

PARTICIPANTS

T Medvedeva

COOPERATIONS

Océ Technologies

FUNDED

HIPRINS

University -

FOM -

STW -

NWO Other -

Industry -

TNO -

GTI -

EU 100 %

Scholarships -

START OF THE PROJECT

2011

INFORMATION

JJW van der Vegt

053 489 5628

j.j.w.vandervegt@math.utwente.nl

www.home.math.utwente.nl/~vegtjjw/

MULTISCALE MODELING & SIMULATION



Prof.dr.ir. BJ Geurts



Prof.dr. JGM Kuerten



Prof.dr. HJH Clercx

I am a scientist, trained as theoretical physicist and applied mathematician, holding the chair for Multiscale Modeling and Simulation at the University of Twente and for Anisotropic Turbulence at Eindhoven University of Technology. My research focus is on mathematics, physics and numerics of multiscale problems in turbulence, mixing, complex fluids and biology. I try to find simplicity behind complexity, find structures and what combines, rather than what separates. I contribute to 3TU.AMI, ERCOFTAC, TGS Computational Science and act as HoD of Applied Mathematics in Twente.

PROJECT AIM

Develop an accurate method with which evaporation and condensation of water in air can be simulated for dispersed droplet-laden turbulent flow in a channel. Understand turbulence-phase transition interactions.

PROGRESS

The paper dedicated to the validation and testing of the new developed algorithm for droplet-laden turbulent channel flow with phase transitions at low Mach numbers was submitted. The new paper dedicated to the study of the sensitivity of the flow to compressibility at low values of the initial relative humidity was published. Effects of gravity were included in the mathematical model and first test cases were simulated and analyzed.

DISSERTATIONS

-

SCIENTIFIC PUBLICATIONS

1. Bukhvosova, A., Russo, E., Kuerten, J.G.M. & Geurts, B.J. (2014). Comparison of DNS of compressible and incompressible turbulent droplet-laden heated channel flow with phase transition. *International Journal of Multiphase Flow*, 63, 68-81.
2. Bukhvosova, A., Kuerten, J.G.M. and Geurts, B.J. (2014). Low Mach number algorithm for droplet-laden turbulent channel flow with phase transition . Submitted and revised to *Journal of Computational Physics*.
3. Bukhvosova, A., Russo, E., Kuerten, J.G.M. & Geurts, B.J. (2014). DNS of turbulent droplet-laden heated channel flow with phase transition at different initial relative humidities. *International Journal of Heat and Fluid Flow*, 50, 445-455.
4. Bukhvosova, A., Kuerten, J.G.M. and Geurts, B.J. (2014). DNS of turbulent channel flow subject to oscillatory heat flux. In *Proceedings of HEAT2014*, Krakow, July 2014.

PROJECT LEADERS

BJ Geurts

RESEARCH THEME

Mathematical and computational methods for fluid flow analysis

PARTICIPANTS

A Bukhvosova, H Kuerten

COOPERATIONS

-

FUNDED

| | |
|--------------|-------|
| FOM | |
| University | - |
| FOM | 100 % |
| STW | - |
| NWO Other | - |
| Industry | - |
| TNO | - |
| GTI | - |
| EU | - |
| Scholarships | - |

START OF THE PROJECT

2011

INFORMATION

A Bukhvosova
053 489 3384
a.bukhvosova@utwente.nl

PROJECT LEADERS

BJ Geurts

RESEARCH THEME

Mathematical and computational methods for fluid flow analysis

PARTICIPANTS

M Stanic, AK Kuczaj

COOPERATIONS

Philip Morris Products S.A.

FUNDED

Philip Morris International S.A.

University -

FOM -

STW -

NWO Other -

Industry 100 %

TNO -

GTI -

EU -

Scholarships -

START OF THE PROJECT

2013

INFORMATION

BJ Geurts

053 489 4272

b.j.geurts@utwente.nl

www.utwente.nl/ewi/mms/people/

personalpages/personalpage_geurts/

PROJECT AIM

Porous media flows, from a numerical point of view, are primarily characterized by a sudden change of domain properties, namely the porosity of the domain at the fluid-porous interface. This sudden change of domain properties may cause numerical oscillations in the solution of the flow field. In this project we develop new numerical methods that treat jumps in permeability physically consistently, avoiding unphysical oscillations. The new simulation software will ultimately deal with a range of complex phenomena, such as the combination of porous flow with conjugate heat-transfer in which simultaneously aerosol is generated and transported.

PROGRESS

Developed and applied the ReDistributed Resistance (RDR) and Face Consistent Pressure (FCP), for removing the spurious oscillations in the velocity field solutions. In addition to the above methods, capabilities for non-equilibrium heat transfer and compressibility effects have been included in the solver. The codes were validated and showed good behavior on a variety of grids.

DISSERTATIONS

-

SCIENTIFIC PUBLICATIONS

1. M. Stanic, M. Nordlunc, A.K. Kuczaj, E.M.A. Frederix, B.J. Geurts, 2014. Oscillation Free Methods for Modeling Fluid-Porous Interfaces Using Segregated Solvers on Unstructured Grids , APS DFD presentation, November 2014 San Francisco, USA.

MULTI-SCALE MODELING AND SIMULATION OF AEROSOL NUCLEATION

PROJECT AIM

In this project, we develop a model for the description of aerosol droplet production, evolution and transport. The goals are 1) to identify a suitable aerosol model which is capable of predicting aerosol size distributions and composition, depending on processes such as nucleation, condensation, coagulation and deposition and 2) to develop effective numerical methods to find, within reasonable computational time, a solution to the aerosol model, in 3D flow.

PROGRESS

In the past year a sectional formulation of an aerosol model was developed. The size distribution of aerosol droplets is represented by a number of discrete droplet sizes, or sections. The governing equations are solved with respect to these sections. A method was developed which is 1) robust and does not contain a severe time step restriction and 2) accurate as a pre-defined number of moments of the size distribution may be preserved. The method was applied to a spatially homogeneous setting, and compared with analytical results.

DISSERTATIONS

-

SCIENTIFIC PUBLICATIONS

1. Frederix, E.M.A. and Kuczaj, A.K. and Nordlund, M. and Stanic, M. and Geurts, B.J. (2014) Characteristics-based sectional modeling of aerosol nucleation, condensation and transport. In: 67th Annual Meeting of the APS Division of Fluid Dynamics, 23-25 November 2014, San Francisco, CA, USA.
2. Frederix, E.M.A. and Kuczaj, A.K. and Nordlund, M. and Geurts, B.J. (2014) Capturing aerosol droplet nucleation and condensation bursts using PISO and TVD schemes. In: 6th European Conference on Computational Fluid Mechanics, ECFD 2014, 20-25 July 2014, Barcelona, Spain (pp. pp. 3462-3472).

PROJECT LEADERS

BJ Geurts

RESEARCH THEME

Mathematical and computational methods for fluid flow analysis

PARTICIPANTS

EMA Frederix, AK Kuczaj

COOPERATIONS

Philip Morris International

FUNDED

Philip Morris International S.A.

University -

FOM -

STW -

NWO Other -

Industry 100 %

TNO -

GTI -

EU -

Scholarships -

START OF THE PROJECT

2012

INFORMATION

E Frederix

06 46618936

e.m.a.frederix@utwente.nl

www.utwente.nl/ewi/mms

PROJECT LEADERS

BJ Geurts

RESEARCH THEME

Mathematical and computational methods for fluid flow analysis

PARTICIPANTS

P Cifani, JGM Kuerten

COOPERATIONS

GJM Priem, WR Michalek, CWM van der Geld (TUE)

FUNDED

| | |
|--------------|-------|
| STW | |
| University | - |
| FOM | - |
| STW | 100 % |
| NWO Other | - |
| Industry | - |
| TNO | - |
| GTI | - |
| EU | - |
| Scholarships | - |

START OF THE PROJECT

2013

INFORMATION

P Cifani
053 489 3414
p.cifani@utwente.nl
www.utwente.nl/ewi/mms/

PROJECT AIM

For the design of evaporator tubes used in various types of conventional power plants, medium-size boilers and waste incinerators, knowledge of flow pattern changes under the influence of external heating is of utmost importance to warrant safe operation. The project is focused on the development and validation of a numerical method based on a multi-scale approach to boiling flows. The proposed research will produce a validated, reliable and versatile prediction tool as well as a set of practical flow pattern maps for heated two-phase flows.

PROGRESS

A two-phase flow model with phase-change was successfully implemented in the open source CFD tool OpenFOAM. A kinetic-based mass transfer rate was adopted and linked to a continuous representation of the flow by the volume of fluid method (VOF). As a main result, several simulations of a rising bubble with mass and heat transfer in a viscous liquid were carried out.

DISSERTATIONS

-

SCIENTIFIC PUBLICATIONS

1. P. Cifani, J.G.M. Kuerten, B.J. Geurts. 2014: Kinetic-based phase change approach for VOF method applied to two-phase flows APS, Division of Fluid Dynamics, San Francisco, 24/11/2014.

LARGE SCALE COMPUTATIONS OF RAYLEIGH-BÉNARD CONVECTION

PROJECT AIM

We aim to develop an efficient numerical method for direct numerical simulations of Rayleigh-Bénard convection. Turbulent flows at high Rayleigh numbers are challenging to solve numerically and require long computing times, even on today's large supercomputers. Current numerical solvers are limited in the number of processors that can be used efficiently. By parallelizing the problem in time, in addition to a traditional parallelization in space, we may deploy many more processors in parallel and reduce the computing time significantly.

PROGRESS

We analyzed the performance and accuracy of the open-source spectral element method Nek5000 for simulations of Rayleigh-Bénard convection. This code will provide the basis for the future development of a time-parallel method. We found good agreement with the finite volume method, which is being used by various groups working in the field of Rayleigh-Bénard convection. As a test problem, we studied the scaling of heat transfer in rotating Rayleigh-Bénard convection. We presented the results of this parameter study at ERCOFTAC's ETMM10 conference, and the corresponding paper is selected for publication in a special issue of Int. J. Heat Fluid Flow.

DISSERTATIONS

-

SCIENTIFIC PUBLICATIONS

1. G.L. Kooij, M.A. Bochev, B.J. Geurts, 2014: Direct numerical simulation of rotating Rayleigh-Benard convection, Proceedings ETMM10, Marbella, September 17-19.

PROJECTLEADERS

BJ Geurts

RESEARCHTHEME

Mathematical and computational methods for fluid flow analysis

PARTICIPANTS

G Kooij, M Botchev

COOPERATIONS

Dr. Rudie Kunnen (TUE)

FUNDED

| | |
|--------------|-------|
| FOM | |
| University | - |
| FOM | 100 % |
| STW | - |
| NWO Other | - |
| Industry | - |
| TNO | - |
| GTI | - |
| EU | - |
| Scholarships | - |

START OF THE PROJECT

2013

INFORMATION

G Kooij

g.l.kooij@utwente.nl

www.utwente.nl/ewii/mms/



Prof.dr.ir. CH Venner



Prof.dr.ir. HWM Hoeijmakers



Prof.dr.ir. A Hirschberg

Modern engineering challenges concern the design and development of processes and equipment with a high performance and minimal environmental impact, i.e. effective use of resources, energy and minimal generation of waste products and noise. The Engineering Fluid Dynamics group aims to contribute to innovative solutions for practically relevant societal, environmental and industrial challenges by bringing "fundamental" physics to actual applications on many scales, ranging from large size high power such as aircraft parts, compressors, and turbines, to small-scale thin-layer free surface flows in lubrication and bearing applications. The research is both experimental and theoretical, including numerical simulations with in house development of accurate numerical codes and multilevel/multigrid computational methodologies. The research focuses on the following themes:

FLUID MECHANICS OF ROTATING FLOW MACHINES

The flow in centrifugal pumps, compressors, and around wind turbine blades. The research involves optimization of the functional aspects (blade/impeller geometry, cavitation characteristics, efficiency, active flow control) as well as the minimization of non-drag related energy losses in the lubrication and transition layers, and minimization of environmental aspects such as the reduction of vibrational and (aeroacoustic) noise. For this purpose, an aeroacoustic test facility is used: A silent closed circuit wind tunnel with a (0.7x0.9 m²) free-jet test-section (maximum velocity 65 m/s) which is enclosed by a 6x6x4m³ anechoic chamber.

MULTI-PHASE FLOWS AND WAVE PHENOMENA

Flows with phase transition occur in many engineering applications such as flow of oil/water/gas mixtures in hydrocarbon transport lines, ice accretion on aircraft wings in flight, flows with cavitation, separation of mixtures, and dense-phase fluid particle flows in dredging applications. The group develops computational methods for specific applications aimed at actual design and prototyping and also carries out fundamental studies, on the mechanisms of e.g. condensation, in multiphase systems. Research is also carried out aimed at identifying the acoustic signature of the flow.

COMPUTATIONAL AERODYNAMICS ALGORITHM DESIGN

Practical applications in engineering involve the occurrence of phenomena on largely different scales in almost any application. In such cases both high order accuracy as well as computational efficiency are of the utmost importance. The group develops and tests numerical algorithms for simulation and optimization, and validates predictions for actual applications ranging from Navier Stokes and Euler equations to potential flows, and reduced systems such as lubrication flows with combined elasticity on nano-scale. Aspects of development are high order compact schemes, multigrid/multilevel computational methodologies and gradient based adjoint optimization.

BIO-PHYSICAL FLOWS

This research deals with the flow in (bio)medical and natural systems. Projects include flow in lungs (aerosol deposition), medical sprays, and separation of specific cell rich flows. Research is aimed at developing new (computational) diagnostic and therapeutic tools. Research in nature-inspired flows is aimed at the development of robot-birds and minimizing the impact of technology on the natural environment.

PROJECT AIM

Numerical simulation of ice accretion in the first stages of a compressor of an aircraft engine due to the presence of ice crystals at high altitude. The Eulerian approach for predicting the droplet trajectories will be used, combined with the (modified) Messinger model for the actual ice accretion.

PROGRESS

Calculations have been performed on TRL4 test cases to investigate the influence of ice crystal sphericity on particle trajectories and heat transfer. The Eulerian model equations have been extended to include particle evaporation and melting. The correlations for the drag coefficient and the Nusselt number now depend on the particle's sphericity.

The collection efficiency results are shown for cylindrically-shaped ice particles impacting on a 2D Naca-0012 airfoil. Three different drag correlations (Ganser [1993], Haider and Levenspiel [1989] and Holzer and Sommerfeld [2008]) are compared to the reference correlation of Clift and Gauvin [1970]. The particles in left figure 1 (run6) have an aspect ratio of 1.0 and the particles figure 2 (run10) have an aspect ratio of 10 (long cylinder).

DISSERTATIONS

-

SCIENTIFIC PUBLICATIONS

1. E. Norde, J.M. Hospers, E.T.A. van der Weide, H.W.M. Hoeijmakers, Splashing Model for Impact of Supercooled Large Droplets on a Thin Liquid Film, 2014, AIAA Paper 2014-0738, National Harbor, MD, United States.
2. E. Norde, J.M. Hospers, E.T.A. van der Weide, H.W.M. Hoeijmakers, Aircraft Icing in Flight: Effects of Impact of Supercooled Large Droplets, 2014, ICAS Paper 2014-0925, St. Petersburg, Russia.
3. R.J. Astley, R. Sugimoto, G. Gabard, E. Norde, E.J. Grift, M. Bocquier, The Effect of Steady Flow Distortion on Mode Propagation in a Turbofan Intake, 2014, AIAA Paper 2014-3113, Atlanta, GA, United States.

PROJECT LEADERS

HWM Hoeijmakers, ETA van der Weide

RESEARCH THEME

Mathematical and computational methods for fluid flow analysis

PARTICIPANTS

E Norde, ETA van der Weide, HWM Hoeijmakers

COOPERATIONS

Onera, CIRA, EADS, Darmstadt Univ., TsAGI

FUNDED

| | |
|--------------|------|
| EU | |
| University | 25 % |
| FOM | - |
| STW | - |
| NWO Other | - |
| Industry | - |
| TNO | - |
| GTI | - |
| EU | 75 % |
| Scholarships | - |

START OF THE PROJECT

2013

INFORMATION

ETA van der Weide
053 489 2593
e.t.a.vanderweide@utwente.nl

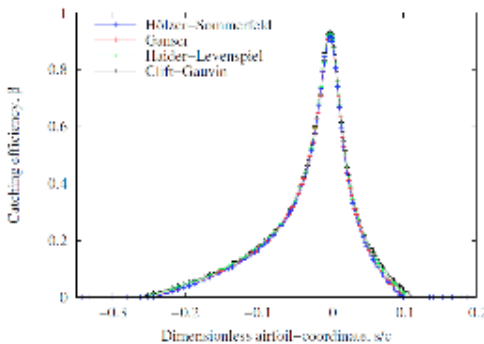

Catching efficiency for particles with aspect ratio 1.0 (run 6).

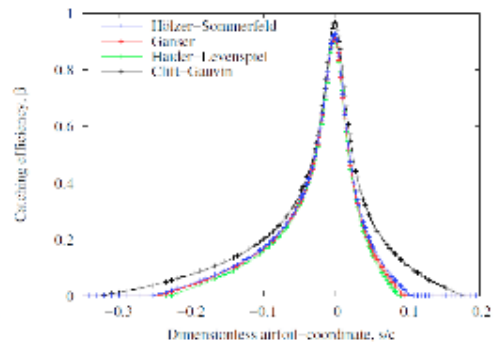

Catching efficiency for particles with aspect ratio 10.0 (run 10)

PREDICTION OF THE HYDRAULIC PERFORMANCE OF CENTRIFUGAL PUMPS AND FANS

PROJECT LEADERS

NP Kruyt, HWM Hoeijmakers

RESEARCH THEME

Mathematical and computational methods for fluid flow analysis

PARTICIPANTS

RW Westra, NP Kruyt, K van Aniel, HWM Hoeijmakers

COOPERATIONS

Flowserve BV

FUNDED

Senter, UT
University 100 %
FOM -
STW -
NWO Other -
Industry -
TNO -
GTI -
EU -
Scholarships -

START OF THE PROJECT

1998

INFORMATION

NP Kruyt
053 489 2528
n.p.kruyt@utwente.nl

PROJECT AIM

The hydraulic performance of pumps is studied both numerically and experimentally. For the numerical flow simulation, a potential-flow method has been developed for the flow inside centrifugal, mixed-flow pumps as well as axial pumps and fans. The method includes loss models and a cavitation inception model. The method has been extended to include a transpiration-type of model for the effect of sheet cavitation. The experimental work is carried out in the new Rotating Flow facility.

PROGRESS

In 2014 further work has been carried out and publication of results has been realized. The Rotating Flow facility is being redesigned so that higher rotational speeds become possible.

DISSERTATIONS

-

SCIENTIFIC PUBLICATIONS

1. Kruyt, N.P. & Pennings, P.C. & Faasen, R. (2014). Optimization of efficiency of axial fans. Proceedings 12th European Fluid Machinery Congress, pp. 13–20, Woodhead Publishing, Cambridge, UK.

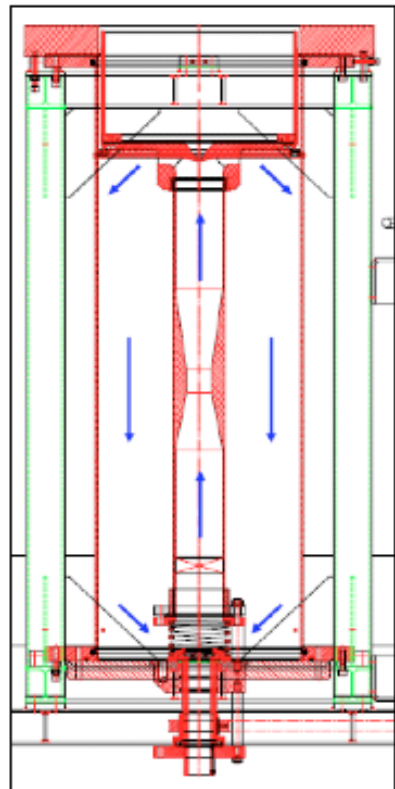
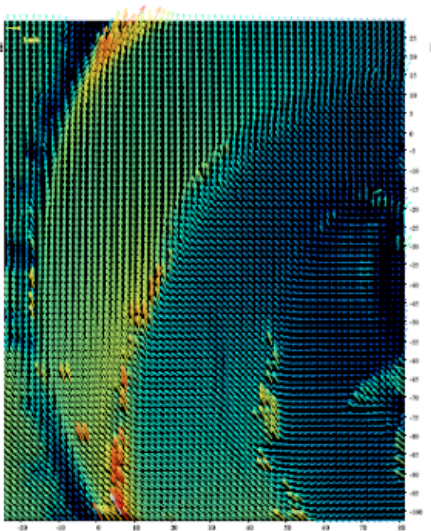

INVERSE DESIGN AND OPTIMISATION METHODS FOR CENTRIFUGAL PUMPS AND FANS

PROJECT AIM

Using the augmented potential-flow method developed for the prediction of the hydraulic performance of centrifugal and mixed flow pumps, two types of design methods for three-dimensional configurations are investigated: (i) inverse-design methods and (ii) optimization methods. The validation of the computational methods has been carried out in the newly developed Rotating Flow facility, by PIV-measurements of the relative velocity field.

PROGRESS

A three-dimensional inverse-design method for impellers of centrifugal pumps has been developed, by which an impeller geometry is obtained that meets the prescribed hydraulic characteristics (rotational speed, flow rate, head and loading). Optimisation methods have been developed in which the performance of centrifugal pump impellers is optimised with respect to required head, low losses and optimal cavitation characteristics. The relative velocity field has been measured at various operating conditions using PIV, in the newly developed Rotating Flow facility. Publications have been effected.

DISSERTATIONS

-

SCIENTIFIC PUBLICATIONS

1. Kruyt, N.P. & Westra, R.W. (2014). On the inverse problem of blade design for centrifugal pumps and fans. *Inverse Problems* 30 065003.
2. Kruyt, N.P. & Pennings, P.C. & Faasen, R. (2014). Optimization of efficiency of axial fans. *Proceedings 12th European Fluid Machinery Congress*, pp. 13–20, Woodhead Publishing, Cambridge, UK.



PROJECT LEADERS

NP Kruyt, HWM Hoeijmakers

RESEARCH THEME

Mathematical and computational methods for fluid flow analysis

PARTICIPANTS

RW Westra, NP Kruyt, K van Anel, HWM Hoeijmakers

COOPERATIONS

Flowserve BV, Urenco Aerospace, Johnson Pump, IHC Parts & Services, NLR, Marin

FUNDED

| | |
|--------------|-------|
| STW, UT | |
| University | - |
| FOM | - |
| STW | 100 % |
| NWO Other | - |
| Industry | - |
| TNO | - |
| GTI | - |
| EU | - |
| Scholarships | - |

START OF THE PROJECT

2003

INFORMATION

NP Kruyt
053 489 2528
n.p.kruyt@utwente.nl

PROJECT LEADERS

HWM Hoeijmakers, A Hirschberg

RESEARCH THEME

Mathematical and computational methods for fluid flow analysis

PARTICIPANTS

H de Vries, ETA van der Weide,
A Hirschberg, HWM Hoeijmakers

COOPERATIONS

ECN

FUNDED

ECN, UT

University 30 %

FOM -

STW -

NWO Other -

Industry -

TNO -

GTI 70 %

EU -

Scholarships -

START OF THE PROJECT

2000

INFORMATION

HWM Hoeijmakers

053 489 4838

h.w.m.hoeijmakers@utwente.nl

PROJECT AIM

CFD methods for unsteady flows are developed for the aero-elastic behavior of flexible wind turbine blades. The methods considered range from inviscid flow methods coupled to boundary-layer methods to time-accurate RANS methods. The flow conditions to be considered include cases with dynamic stall. Means for flow control are explored, both experimentally and computationally.

PROGRESS

In 2014 experimental research has been conducted on means for flow control: synthetic jets (SJA's) and Plasma Actuators (PA's). Using piezo-electric elements for SJA's it is now possible to achieve maximum outflow velocities up to 60 m/s. These have been employed in a set-up for flow-separation control as well as in a set-up for load control. Experimental work on PA's have been continued for the case that two opposing PA's produce a jet normal to the wall. Measurements of thrust and jet velocity have been performed. The maximum velocities generated are in the range of 5 to 8 m/s. A start has been made with a set-up employing nano-pulse PA's.

DISSERTATIONS

-

SCIENTIFIC PUBLICATIONS

1. E Koopmans, HWM Hoeijmakers: Experimental Research on Flow Separation Control using Synthetic Jet Actuators. ICAS2014. Paper ICAS2014-0694.
2. H de Vries, ETA van der Weide, HWM Hoeijmakers: Synthetic Jet Actuation for Load Control. Journal of Physics: Conference Series, Vol. 555. Article 012026. ISSN 1742-6588.

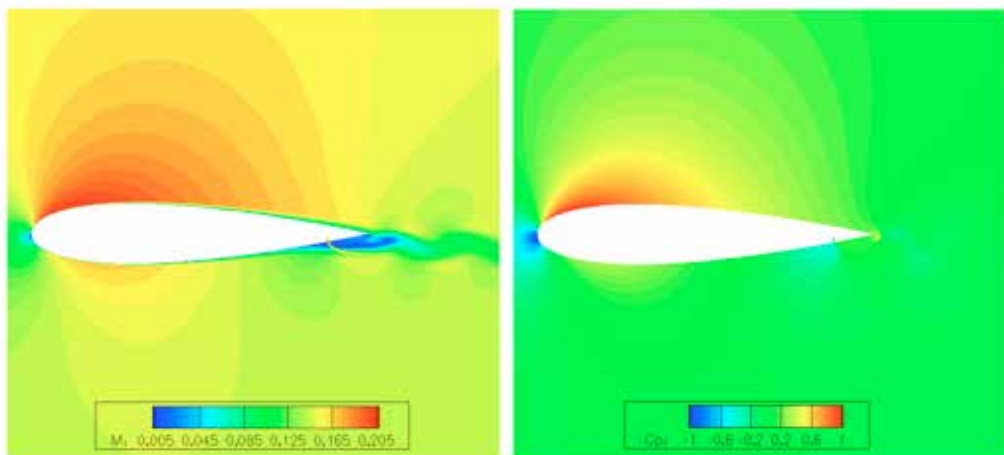

ADVANCED WIND TURBINE BLADE OPTIMIZATION

PROJECT AIM

Development of an aerodynamic analysis tools and integration of these tools into a gradient based optimization framework such that the performance of wind turbine blades can be optimized according to a (user defined) objective function.

PROGRESS

In 2014 this program was finished by completing the thesis.

DISSERTATIONS

1. S.H. Jongsma, On a Method for Simulation-Based Wind Turbine Design. 2014.

SCIENTIFIC PUBLICATIONS

-

PROJECT LEADERS

HWM Hoeijmakers, ETA van der Weide

RESEARCH THEME

Mathematical and computational methods for fluid flow analysis

PARTICIPANTS

SH Jongsma, ETA van der Weide, HWM Hoeijmakers

COOPERATIONS

Suzlon Blade Technology

FUNDED

Suzlon Blade Technology

University -

FOM -

STW -

NWO Other -

Industry 100 %

TNO -

GTI -

EU -

Scholarships -

START OF THE PROJECT

2008

INFORMATION

ETA van der Weide

053 489 2593

e.t.a.vanderweide@utwente.nl

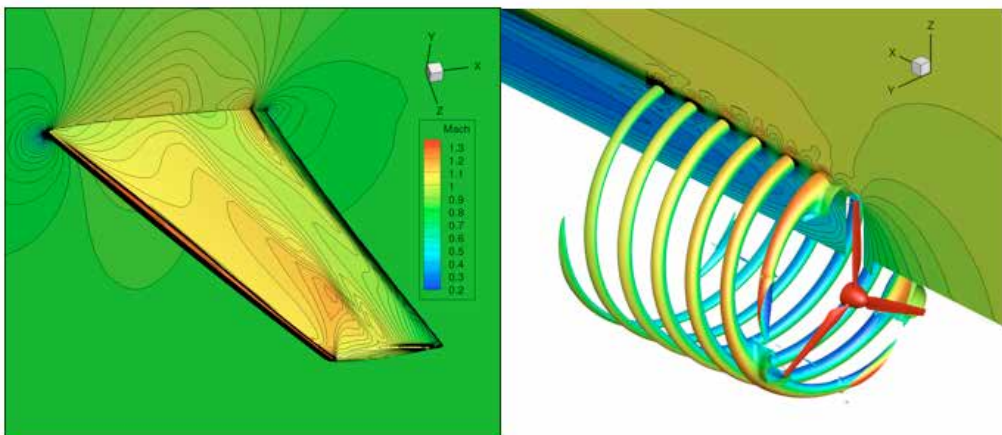

Solution of an aerodynamic shape optimization problem for a wing subject to transonic flow conditions.

Iso-density surface colored with the axial velocity for the flow around an isolated rotor.

PROJECT LEADERS

HWM Hoeijmakers, ETA van der Weide

RESEARCH THEME

Mathematical and computational methods for fluid flow analysis

PARTICIPANTS

ETA van der Weide, HWM Hoeijmakers

COOPERATIONS

-

FUNDED

| | |
|-----------------------|------|
| EU (CleanSky Project) | |
| University | 50 % |
| FOM | - |
| STW | - |
| NWO Other | - |
| Industry | - |
| TNO | - |
| GTI | - |
| EU | 50 % |
| Scholarships | - |

START OF THE PROJECT

2009

INFORMATION

ETA van der Weide
053 489 2593
e.t.a.vanderweide@utwente.nl

PROJECT AIM

Investigate the possibility to apply synthetic jet flow control on the flaps of aircraft wings in order to increase the lift during take off and landing. The goal of this research is to determine the specifications of a synthetic jet flow control device in order to accomplish the desired effects.

PROGRESS

Due to the fact that detailed experiments for the performance of the actuators were only carried out in the very end of 2014, no new simulations for the IACD (Integrated Active Component Demonstrator) have been carried. The steady state simulations have been redone with the open source code SU2, which confirmed the relatively small gain in performance using steady blowing.

DISSERTATIONS

-

SCIENTIFIC PUBLICATIONS

-

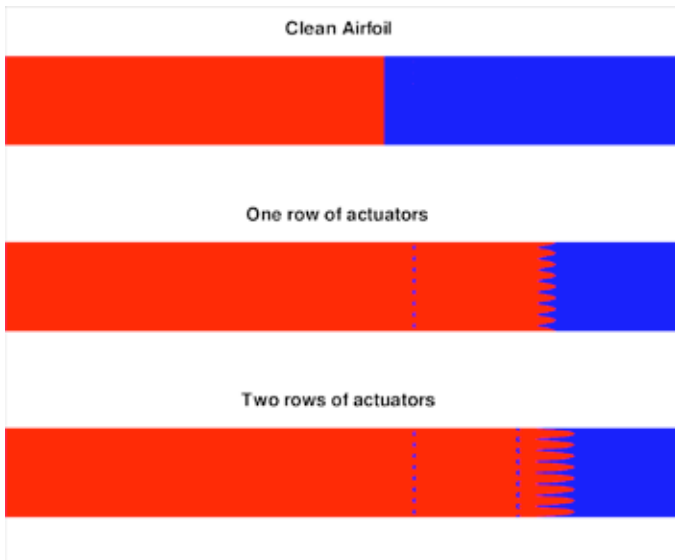

Top view of the separation length for the clean airfoil, one row of actuators and two rows of actuators. Red is attached flow, blue is separated flow. The flow is from left to right.

ICE ACCRETION ON AIRCRAFT WINGS

PROJECT AIM

Numerical simulation of ice accretion on aircraft wings in flight at (extreme) icing conditions, including effects of splashing of large super-cooled droplets on impact, droplet breakup in high-shear regions of the flow, droplet coalescence.

PROGRESS

Starting point has been a potential flow method coupled to a Lagrangian method to predict the water collection efficiency and to Messinger's model for the freezing thin layer of water along the surface. This method has been extended to poly-disperse droplet distributions and the capability to treat multi-element airfoil sections. Also a splashing-droplet model as well as a bouncing-droplet model has been adapted and implemented. Furthermore an Eulerian method for predicting the water collection efficiency has been developed, which is more suitable for complex configurations. Furthermore an unstructured-grid Euler method for compressible flow has adapted for coupling to the ice-accretion models. The method has been extended to ice accretion on 3D swept wings.

DISSERTATIONS

-

SCIENTIFIC PUBLICATIONS

1. E. Norde, JM. Hospers, E. van der Weide, HWM. Hoeijmakers: Splashing model for impact of supercooled large droplets on a thin liquid film. AIAA Paper 2014-0738.

PROJECT LEADERS

HWM Hoeijmakers

RESEARCH THEME

Mathematical and computational methods for fluid flow analysis

PARTICIPANTS

JM Hospers, HWM Hoeijmakers

COOPERATIONS

TU Darmstadt, CIRA, INTA, ONERA

FUNDED

| | |
|--------------|------|
| EU, UT | |
| University | 20 % |
| FOM | - |
| STW | - |
| NWO Other | - |
| Industry | - |
| TNO | - |
| GTI | - |
| EU | 80 % |
| Scholarships | - |

START OF THE PROJECT

2008

INFORMATION

HWM Hoeijmakers

053 489 4428

h.w.m.hoeijmakers@utwente.nl

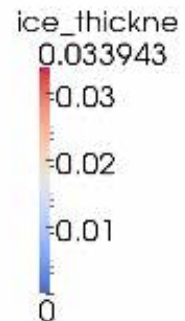
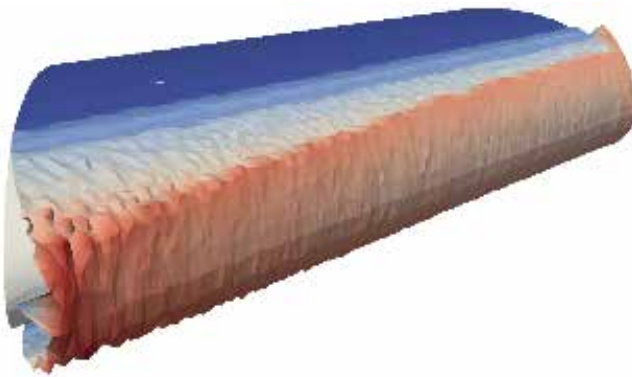

PROJECT LEADERS

HWM Hoeijmakers, A Hirschberg

RESEARCH THEME

Complex dynamics of fluids

PARTICIPANTS

A Hirschberg, BJW Molenaar, J Haas,
X Pelorson, PMG Hoeijmakers, B
Lemoine, L Le Marrec, C Kameni
Djuimo, Ph Bequin, J-P Dalmont,
J Gilbert

COOPERATIONS

Institut Polytechnique de Grenoble
(GIPSA), TU/e (Mech. Engineering),
Université du Maine (LAUM),
Université de Rennes (Applied
Math.)

FUNDED

| | |
|--------------|-------|
| UT | |
| University | 100 % |
| FOM | - |
| STW | - |
| NWO Other | - |
| Industry | - |
| TNO | - |
| GTI | - |
| EU | - |
| Scholarships | - |

START OF THE PROJECT

1999

INFORMATION

HWM Hoeijmakers
053 489 4838
h.w.m.hoeijmakers@utwente.nl

PROJECT AIM

Investigate experimentally the flow over discontinuities, cavities, airfoils, blunt bodies, etc. For this purpose the existing 0.9*0.7 m2 (50 m/s) closed test section aerodynamic wind tunnel has been developed to an Aero-Acoustic Test facility (silent wind tunnel) with 0.9*0.7 m2 (65 m/s) open jet test section within a 6x6x4m3 anechoic chamber.

PROGRESS

An experimental study of the acoustic response of a diffuser flow with marginal stall has been carried out (Msc thesis B.J.W. Molenaar).

A low frequency approximation has been proposed for the acoustic radiation from an open pipe termination exhausting a hot gas.

The influence of the Coanda effect on human speech production has been studied (IPG/ GIPSA).

A study is initiated in collaboration with the Laboratoire d'Acoustique de l'Université du Maine (LAUM) on efficient high amplitude sound sources.

A study on the influence of stiction on the noise generated by valves has been initiated in collaboration with the University of Rennes (Dept. Applied Math.).

DISSERTATIONS

-

SCIENTIFIC PUBLICATIONS

1. A.Hirschberg and P.G.M. Hoeijmakers, "Comments on the low frequency radiation impedance of a duct exhausting a hot gas", Journal of the Acoustical Society of America, 136 (2014) EL-84-89.
2. O. Rudenko, G. Nakiboglu, A. Hirschberg, "Onset of tonal noise in corrugated pipe segments", Journal of Pressure Vessel Technology, ASME 136 (2014) 051303-1/8.
3. A.Hirschberg, J. Haas, X. Pelorson, "Asymmetry in lateral forces on vocal folds due to the Coanda effect", proceedings of the 12th Conference Française d'Acoustique (CFA), Poitiers, 15-22 April 2014, paper 114.
4. J. Haas, X. Pelorson, A.Hirschberg, "The Coanda effect and asymmetries in vocal fold models during phonation", proceedings of the 12th Conference Française d'Acoustique (CFA), Poitiers, 15-22 April 2014, paper 255.

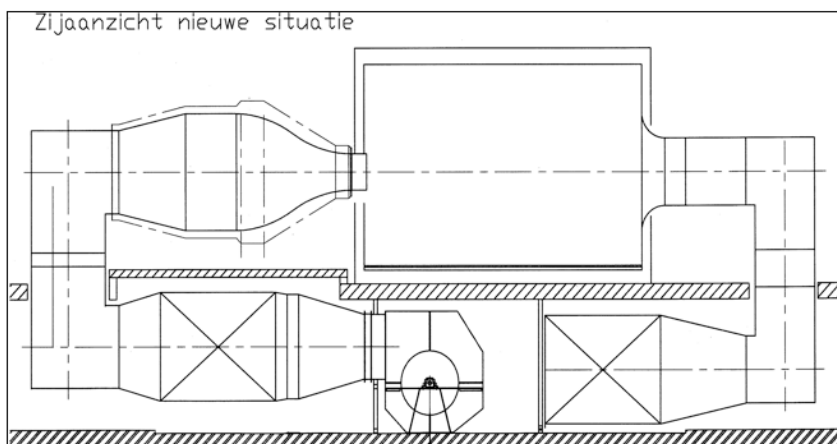

COPA-GT, STUDY OF HIGHER ORDER ENERGY-STABLE DISCRETIZATION TECHNIQUE FOR TURBOMACHINERY APPLICATIONS

PROJECT AIM

The research is theoretical/numerical and focuses on the development of an highly efficient parallel multiblock structured code for turbomachinery applications. The goal is to assess whether or not high order energy stable schemes are more efficient for such problems. In fact, the most widely used commercial codes typically provide a 2nd order accurate discretization of the Navier-Stokes equations. The question is if it possible to obtain the same solution making use of high order (≥ 3 rd) numerical methods and at the same time reducing the number of points of the numerical grid. This would lead to large saving in terms of computational time.

PROGRESS

A stable and consistent sliding mesh interface treatment has been developed for a linear cascade and tested. These tests show that the overall accuracy of the method is preserved when carrying out the interpolation on the sliding interface. Furthermore, RANS turbulence models have been implemented using the same high order discretization schemes. The high order discretization has been compared to other high order discretization during the workshop for high order schemes, held in Kissimmee during the AIAA conference. Very good results have been obtained for both accuracy and efficiency for complex test cases.

DISSERTATIONS

-

SCIENTIFIC PUBLICATIONS

1. G. Giangaspero, M. Almqvist, K. Mattsson, and E. van der Weide. Unsteady simulations of rotor stator interactions using SBP-SAT schemes: status and challenges For the book series 'Lecture Notes in Computational Science and Engineering', Springer. – under revision.
2. E. van der Weide, G. Giangaspero, and M. Svärd. Efficiency Benchmarking of an Energy Stable High-Order Finite Difference Discretization. AIAA-journal, doi: 10.2514/1.J053500.

PROJECT LEADERS

HWM Hoeijmakers, ETA van der Weide

RESEARCH THEME

Mathematical and computational methods for fluid flow analysis

PARTICIPANTS

G Giangaspero, ETA van der Weide

COOPERATIONS

VKI, Cerfacs, RWT, Turbomeca, BSC, Siemens, Loughborough Univ

FUNDED

| | |
|--------------|------|
| EU | |
| University | 25 % |
| FOM | - |
| STW | - |
| NWO Other | - |
| Industry | - |
| TNO | - |
| GTI | - |
| EU | 75 % |
| Scholarships | - |

START OF THE PROJECT

2012

INFORMATION

ETA van der Weide
053 489 2593
e.t.a.vanderweide@utwente.nl

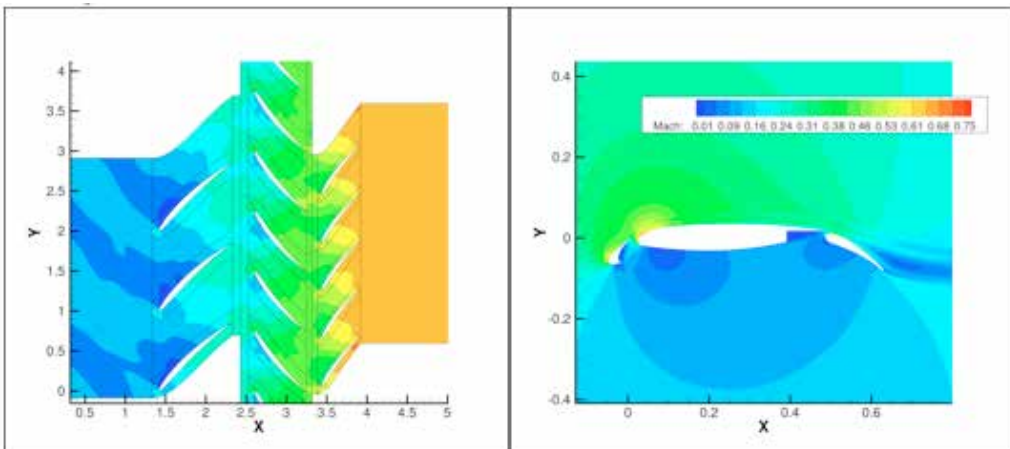

Pressure contours in a linear cascade in which the rotor (middle) is moving upwards relative to the two stators. 3rd order SBP/SAT discretization

Mach number contours for the flow over a three element airfoil. 4th order SBP/SAT discretization

PROJECT LEADERS

HWM Hoeijmakers, ETA van der Weide

RESEARCH THEME

Mathematical and computational methods for fluid flow analysis

PARTICIPANTS

SH Jongsma, ETA van der Weide, HWM Hoeijmakers

COOPERATIONS

MARIN

FUNDED

| | |
|--------------|-------|
| MARIN | |
| University | - |
| FOM | - |
| STW | - |
| NWO Other | - |
| Industry | 100 % |
| TNO | - |
| GTI | - |
| EU | - |
| Scholarships | - |

START OF THE PROJECT

2014

INFORMATION

ETA van der Weide
053489 2593
e.t.a.vanderweide@utwente.nl

PROJECT AIM

Investigate experimentally and numerically the flow about nature-inspired configurations, such as the Robot Birds of Robert Musters. These nature-inspired copies of real birds combine lift and propulsion by flapping wings. In the project (scale-models of) these, and others, configurations are investigated in the wind tunnel and numerically.

PROGRESS

Wind-tunnel experiments have been carried out for a rigid, stationary model of the wing of the peregrine bird. Results have been presented at an AIAA conference. A start has been made on numerical simulations and on the design of a set-up for wind-tunnel experiments on a configuration with rigid flapping wings.

DISSERTATIONS

-

SCIENTIFIC PUBLICATIONS

-

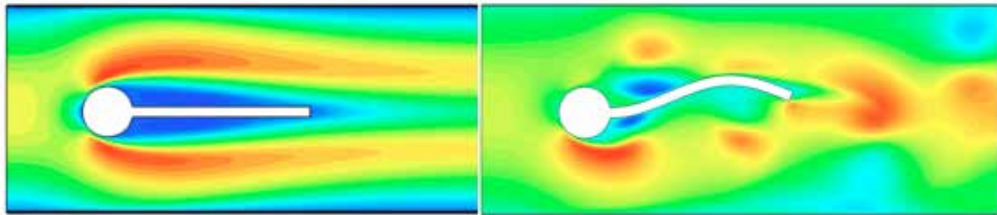

Steady solution of the flow around a cylinder with a rigid plate attached

Unsteady solution of the flow around a cylinder with a flexible plate attached

DYNVOR : THE DYNAMICS OF VORTEX CAVITATION ON SHIP PROPULSORS AND PUMP IMPELLERS

PROJECT AIM

The aim of this project is: (i) to enhance the understanding of the contribution of cavitating vortices to cavitation vibration and cavitation erosion and (ii) to develop a simulation code capable of predicting flows with cavitating vortices. It is believed that Large Eddy Simulation (LES) for the modeling of turbulence is a key tool for the success of such a simulation code. Typical applications where this type of flow occurs are flows around ship propulsors and flows in pumps.

PROGRESS

A detailed study of the thermodynamic model used to describe the cavitation showed that the speed of sound of this model is discontinuous in the regions where a phase transition occurs. This behavior leads to stability problems during the simulations and therefore an inconsistent speed of sound is used. The cavitation model itself has been implemented in the open source code SU2 and simulations have been carried. When an inviscid assumption is made, explicit time integration schemes can still be used. However, this is not the case anymore when the Navier-Stokes equations are solved. The stability criterion for the small cells in the boundary layer leads to unacceptably small time steps for explicit time integration schemes. Therefore a start is made to use implicit schemes.

DISSERTATIONS

-

SCIENTIFIC PUBLICATIONS

1. F. Khatami, E. van der Weide and H. Hoeijmakers. Single fluid cavitation model: thermodynamic inconsistencies, and second and higher order accurate numerical discretizations 3rd ICR cavitation workshop, City University, London.
2. F. Khatami, E. van der Weide and H. Hoeijmakers. Multi-Phase Thermodynamic Tables for Efficient Numerical Simulation of Cavitating Flows: a novel look-up approach towards Efficient and Accurate Tables Heat Transfer Engineering Journal (HTE).

PROJECT LEADERS

HWM Hoeijmakers, ETA van der Weide

RESEARCH THEME

Mathematical and computational methods for fluid flow analysis

PARTICIPANTS

F Khatami, ETA van der Weide, HWM Hoeijmakers

COOPERATIONS

Wärtsilä, IHC Merwede, Flowserve

FUNDED

| | |
|--------------|------|
| AgentschapNL | |
| University | - |
| FOM | - |
| STW | - |
| NWO Other | - |
| Industry | 25 % |
| TNO | - |
| GTI | - |
| EU | 75 % |
| Scholarships | - |

START OF THE PROJECT

2011

INFORMATION

ETA van der Weide
053 489 2593
e.t.a.vanderweide@utwente.nl

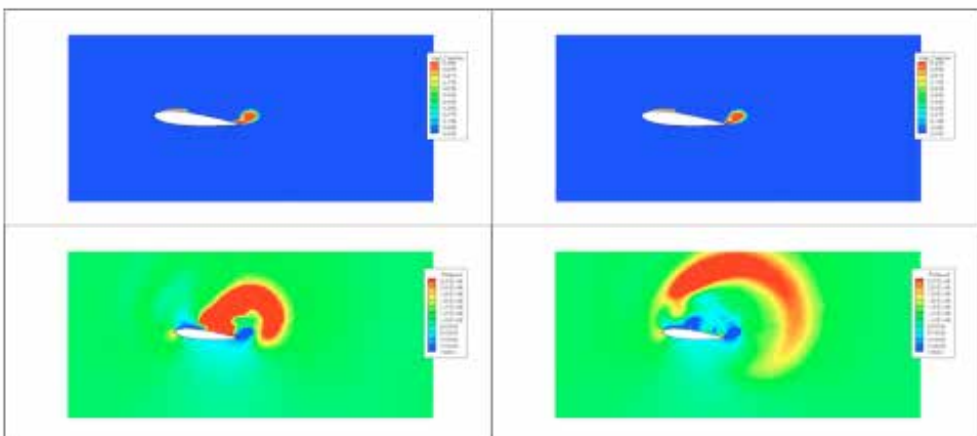

Void fraction and pressure during the implosion of the void.

PROJECT LEADERS

HWM Hoeijmakers

RESEARCH THEME

Mathematical and computational methods for fluid flow analysis

PARTICIPANTS

JJ Slot, HWM Hoeijmakers

COOPERATIONS

TUD, Tue, Shell, FMC Separation Systems, Frames, Wintershall, WUR

FUNDED

| | |
|--------------|------|
| ISPT, UT | |
| University | 20 % |
| FOM | - |
| STW | - |
| NWO Other | - |
| Industry | 80 % |
| TNO | - |
| GTI | - |
| EU | - |
| Scholarships | - |

START OF THE PROJECT

2008

INFORMATION

HWM Hoeijmakers
053 489 4428
h.w.m.hoeijmakers@utwente.nl

PROJECT AIM

Modeling and numerical simulation of swirling flow of oil/water mixtures aimed at separation. An experimental set-up is developed at TU Delft for experimental investigation of these flows and providing data for validation. At Wageningen University the behavior of oil-water mixtures is studied at the micro-scale, including droplet coalescence and the effect of surfactants.

PROGRESS

Using CFD, the single-phase swirling water flow in the inline bulk oil-water separator has been considered in detail and agree with experimental measurements. The results show a complex flow pattern with regions of reversed flow. Two-fluid models are employed to study the flow field and separation characteristics. Two-phase experiments are carried out and it will be used to validate the numerical models for these flows. Evolution of the droplet size distribution of the dispersed oil phase will be computed using populations balance models.

DISSERTATIONS

1. LJAM van Campen: Bulk Dynamics of Droplets in Liquid-Liquid Axial Cyclones, Delft University of Technology. ISBN 978-90-7 6464-736-9. January 8, 2014, TU Delft.

SCIENTIFIC PUBLICATIONS

-

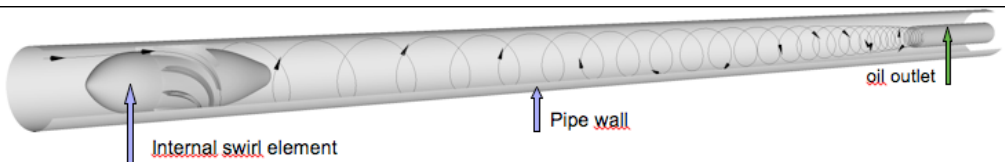

MULTIPHASE FLOW EFFECTS IN COMPACT PRODUCED-WATER TREATMENT EQUIPMENT

PROJECT AIM

The physical phenomena occurring during produced-water treatment are studied numerically. Oil droplet, and gas bubble trajectories will be predicted employing Lagrangian particle tracking for both swirling flow and settling conditions. Influence of effects such as a history term are required for prediction of trajectories. Collision and coalescence are important factors for advanced compact produced-water treatment. Occurrence of such effects is predicted making use of droplet and bubble trajectories.

PROGRESS

A Lagrangian particle tracking method has been developed for generic flow fields. Both implicit Crank-Nicolson, and explicit fourth order Runge-Kutta schemes have been implemented. History force has been identified as force that needs to be investigated. A new expression for the history kernel has been obtained using experimental data from literature to improve existing Reynolds dependent kernel. Efficient collision detection has been implemented in particle tracking code. Two Lattice Boltzmann Methods for liquids have been developed, one using a BGK approach with a body force pressure correction, the other using a BBGKY approach, to investigate the history force in detail. Both explicit and implicit schemes have been implemented. 2-D flow about a cylinder has been investigated to explore the method, and the method has been extended to 3-D flow about a sphere.

DISSERTATIONS

-

SCIENTIFIC PUBLICATIONS

1. DF van Eijkeren, T Krebs, HWM Hoeijmakers: Efficient Collision Detection in a Simulated Hydrocyclone. FACE Conference. London. Journal of Dispersion Science and Technology. December 2014.

PROJECT LEADERS

HWM Hoeijmakers

RESEARCH THEME

Mathematical and computational methods for fluid flow analysis

PARTICIPANTS

DF van Eijkeren, HWM Hoeijmakers

COOPERATIONS

FMC Technologies – Separation Systems, FACE (SINTEF)

FUNDED

FMC Technologies – Separation Systems, FACE (SINTEF)

| | |
|--------------|-------|
| University | - |
| FOM | - |
| STW | - |
| NWO Other | - |
| Industry | 100 % |
| TNO | - |
| GTI | - |
| EU | - |
| Scholarships | - |

START OF THE PROJECT

2009

INFORMATION

DF van Eijkeren
053 489 2482
d.f.vaneijkeren@utwente.nl

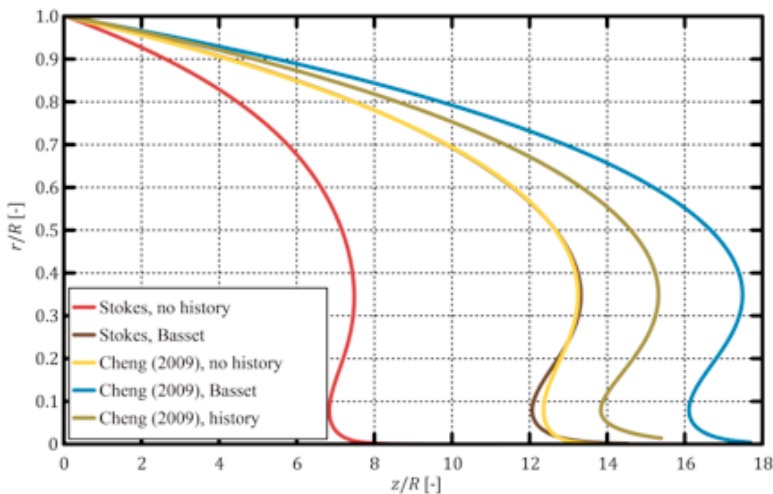

PROJECT LEADERS

CH Venner, HWM Hoeijmakers

RESEARCH THEME

Mathematical and computational methods for fluid flow analysis

PARTICIPANTS

CH Venner, HWM Hoeijmakers, S H Boffy, M van Zoelen (SKF) PM Lugt (SKF), J. Snoeijer (PoF, UT), J Wang (Qingdao), AA Lubrecht (INSA)

COOPERATIONS

Physics of Fluids, UT/TN, INSA-de Lyon, France, Technical University of Brno, Czechia, Qingdao Technological University, PR. China, SKF ERC, Netherlands

FUNDED

| | |
|--------------|------|
| University | 50 % |
| FOM | - |
| STW | - |
| NWO Other | - |
| Industry | 50 % |
| TNO | - |
| GTI | - |
| EU | - |
| Scholarships | - |

START OF THE PROJECT

2007

INFORMATION

CH Venner
053 489 2488
c.h.venner@utwente.nl

PROJECT AIM

Development of accurate thin film/layer flow models and numerical simulation algorithms for the prediction of lubricant film formation capacity and lubrication life in rolling element bearing contacts in relation to operating conditions, lubricant rheology (oil-grease), supply conditions (starved-flooded), and material properties.

PROGRESS

Fundamental aspects and self-similarity in EHL contacts under squeeze conditions were studied identifying the similarity with Marangoni flow on thin layers, thus explaining fundamental aspects of the problem to advance development of engineering models. A novel Multilevel approach was developed which enables simultaneous solution of the lubricated contact problem in (strongly) heterogeneous materials. The efficiency is a novelty providing possibilities for detailed optimization of composite materials in (lubricated contact) applications and application to composite and ceramic material optimization and failure model development.

DISSERTATIONS

-

SCIENTIFIC PUBLICATIONS

1. Venner, C.H., Biboulet, N., Lubrecht, A.A. Boundary Layer behaviour in circular EHL contacts in the piezoviscous regime, Tribology Letters, V 56, 2, pp. 375-380.
2. Boffy, H., Venner, C.H., Multigrid Solution of the 3D Stress-field in strongly heterogeneous materials, Tribology International, V. 74, pp. 121-129.
3. Boffy, H., Venner, C.H., Multigrid Solution of the 3D Elastic subsurface stress field for heterogeneous materials in contact mechanics, proc. 3rd. int. conf. on fracture, fatigue and wear, 1-3 sept 2014, Kitakyushu, Japan. Int. J. of Fracture, Fatigue and Wear, V2, 2014, pp. 295-300.

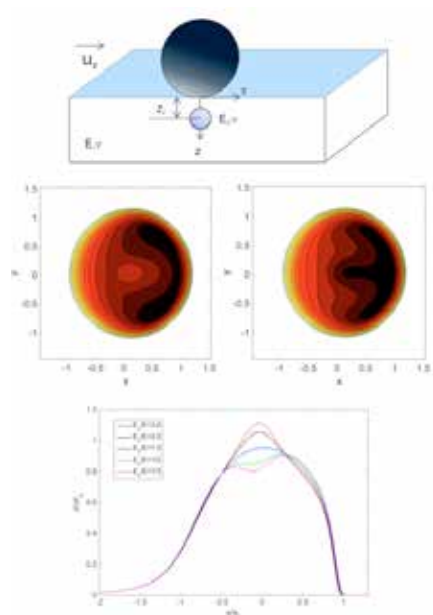

Schematic representation lubricated rolling contact on material with subsurface spherical inclusion (top). Computed contourplots of the film thickness in the lubricated EHL contact for soft (left) and hard (right) inclusion. Contact pressure at the surface in the lubricant film for different ratios of inclusion modulus to bulk material modulus.

MULTISCALE ISLANDS MIXED LUBRICATION MODELING

PROJECT AIM

Development of a mixed lubrication model based on physical first principles representing relevant aspects on different scales to predict the behaviour of concentrated contacts as appearing between rolling elements and raceways in rolling element bearings under extreme operating conditions of very limited lubricant supply.

PROGRESS

Following detailed analysis of the flow around the contact new modeling approaches have been developed. First for to incorporate cavitation in the model using a two-phase relation such that the occurrence of the closed cavitation bubble in the exit of the contact can be predicted. Next, a new model has been developed for the interior high pressure region. The idea is to use local visco-elastic oedometric layer equations. First results show that with such a model the essential features of EHL contacts can be modeled. This proves the conjecture that in this region hardly any flow takes place, as the lubricant is very stiff, much stiffer than the steel of the surfaces. Next activities will be to integrate models and results in thesis.

DISSERTATIONS

-

SCIENTIFIC PUBLICATIONS

-

PROJECT LEADERS

CH Venner, HWM Hoeijmakers

RESEARCH THEME

Mathematical and computational methods for fluid flow analysis

PARTICIPANTS

E van Emden, CH Venner,
HWM Hoeijmakers, GE Morales-
Espejel

COOPERATIONS

SKF

FUNDED

| | |
|--------------|-------|
| SKF | |
| University | - |
| FOM | - |
| STW | - |
| NWO Other | - |
| Industry | 100 % |
| TNO | - |
| GTI | - |
| EU | - |
| Scholarships | - |

START OF THE PROJECT

2009

INFORMATION

CH Venner
053 489 2488
c.h.venner@utwente.nl

PROJECT LEADERS

NP Kruyt

RESEARCH THEME

Mathematical and computational methods for fluid flow analysis

PARTICIPANTS

NP Kruyt

COOPERATIONS

University of Waterloo, Canada;
University of Leeds, UK; Université de La Rochelle, France; Irstea, Grenoble, France

FUNDED

UT

University 100 %

FOM -

STW -

NWO Other -

Industry -

TNO -

GTI -

EU -

Scholarships -

START OF THE PROJECT

2003

INFORMATION

NP Kruyt

053 489 2528

n.p.kruyt@utwente.nl

PROJECT AIM

The study of the (micro-mechanical) behavior of slowly flowing granular materials, in particular of the relation between microscopic behaviour and the macroscopic, continuum behaviour.

PROGRESS

The accuracy of three-dimensional, micromechanical expressions for the strain tensor have been investigated. The most accurate one, due to Bagi, has been used to study the deformation characteristics of granular materials from the micromechanical viewpoint. Elastic properties of granular materials in the isotropic state have been investigated theoretically. Links between macroscopic plasticity and microscopic behaviour have been studied.

DISSERTATIONS

-

SCIENTIFIC PUBLICATIONS

1. Kruyt, N.P. & Millet, O. & Nicot, F. (2014). Macroscopic strains in granular materials accounting for grain rotations. *Granular Matter* 16 933–944.
2. Kruyt, N.P. & Rothenburg, L. (2014). On micromechanical characteristics of the critical state of two-dimensional granular materials. *Acta Mechanica* 225 2301–2318.
3. Kruyt, N.P. (2014). Micromechanical study of elastic moduli of three-dimensional granular assemblies. *International Journal of Solids and Structures* 51 2336–2344.

PROJECT AIM

Inhalation of therapeutic aerosols to treat lung diseases (e.g. asthma) is a problem since the upper airways (nose/mouth region) acts as a natural filter (especially for small subjects (e.g. children)). Results of in vitro measurements and CFD calculations show considerable differences. More over the difficult geometry and non stationair breathing patterns complicate the calculations. The ultimate aim is to predict how and which aerosols should be inhaled to maximize deposition in the required regions and avoid uper airway deposition in the individual patient.

PROGRESS

In the last year a master student (T. Huijgen) worked on his master thesis on CFD calculations for the flow and spray in inhalers and comparison with experiments.

DISSERTATIONS

-

SCIENTIFIC PUBLICATIONS

1. Unilateral atelectasis in a preterm infant monitored with electrical impedance tomography: a case report. van der Burg PS, Miedema M, de Jongh FH, van Kaam AH. *Eur J Pediatr*. 2014 Dec;173(12):1715-7. doi: 10.1007/s00431-014-2399-y. Epub 2014 Aug 23.
2. Protective effect of a low single dose inhaled steroid against exercise induced bronchoconstriction. Visser R, Wind M, de Graaf B, de Jongh FH, van der Palen J, Thio BJ. *Pediatr Pulmonol*. 2014 Nov 21. doi: 10.1002/ppul.23144. [Epub ahead of print].
3. Transcutaneous electromyography of the diaphragm: A cardio-respiratory monitor for preterm infants. Kraaijenga JV, Hutten GJ, de Jongh FH, van Kaam AH. *Pediatr Pulmonol*. 2014 Oct 18. doi: 10.1002/ppul.23116. [Epub ahead of print].
4. Cross-sectional changes in lung volume measured by electrical impedance tomography are representative for the whole lung in ventilated preterm infants. van der Burg PS, Miedema M, de Jongh FH, Frerichs I, van Kaam AH. *Crit Care Med*. 2014 Jun;42(6):1524-30. doi: 10.1097/CCM.000000000000230.

PROJECTLEADERS

HWM Hoeijmakers, FHC de Jongh

RESEARCHTHEME

Mathematical and computational methods for fluid flow analysis

PARTICIPANTS

FHC de Jongh, HWM Hoeijmakers

COOPERATIONS

MST, UVA-AMC

FUNDED

| | |
|--------------|-------|
| UT | |
| University | 100 % |
| FOM | - |
| STW | - |
| NWO Other | - |
| Industry | - |
| TNO | - |
| GTI | - |
| EU | - |
| Scholarships | - |

START OF THE PROJECT

1998

INFORMATION

FHC de Jongh
053 489 4428
f.h.c.dejongh@utwente.nl

PROJECT LEADERS

NP Kruyt, HWM Hoeijmakers

RESEARCH THEME

Mathematical and computational methods for fluid flow analysis

PARTICIPANTS

BJ Konijn, NP Kruyt,
HWM Hoeijmakers

COOPERATIONS

TUD, IHC

FUNDED

| | |
|--------------------|------|
| Agentschap NL, IHC | |
| University | 20 % |
| FOM | - |
| STW | - |
| NWO Other | - |
| Industry | 80 % |
| TNO | - |
| GTI | - |
| EU | - |
| Scholarships | - |

START OF THE PROJECT

2011

INFORMATION

NP Kruyt
053 489 2528
n.p.kruyt@utwente.nl

PROJECT AIM

Aim of the project is to develop a CFD method for the modeling of dense-phase fluid-particulate flow. Firstly, experiments are carried out to determine the dependence of the properties of both liquid and particles on the fluid behavior. With the experimental results, constitutive equations will be constructed. These constitutive relations will be used to develop a CFD method that describes fluid-particulate flow.

PROGRESS

The numerical simulations of mixture flows are continued and expanded. The model is extended with an accurate model for momentum transfer between phases. A specific model has been developed to account for bed formation. The measurements with the rheometer to characterize the behavior of various suspensions, have been continued by an MSc student. It extends the results obtained so far out with measurements of suspensions by the use of other particulate materials and fluid viscosities.

DISSERTATIONS

-

SCIENTIFIC PUBLICATIONS

1. Konijn, B.J. & Sanderink, O.B.J. & Kruyt, N.P. (2014). Experimental study of the viscosity of suspensions: effect of solid fraction, particle size and suspending liquid. *Powder Technology* 266 61–69.

PROJECT AIM

Investigate experimentally and numerically the flow about nature-inspired configurations, such as Robot Birds. These nature-inspired copies of real birds combine lift and propulsion by flapping wings. In the project (scale-models of) these, and others, configurations are investigated in the wind tunnel and numerically.

PROGRESS

Wind-tunnel experiments have been carried out for a flexible model of the wing of the peregrine bird carrying out a flapping motion similar to the true motion. From the velocity distribution measured in the wake employing rake, it is shown that the time-averaged streamwise velocity distribution shows a jet-like pattern. This corresponds to results obtained from numerical simulations (for 2D sections at three spanwise stations) for this wing. These results of numerical simulation have correlated the jet-like pattern with the inverted von Karman vortex street. Such a flow field configuration is associated with a specific phase difference between the heave and pitch motion of the wing. In addition to the Robot birds with flapping wings research has started on the swimming of porpoises in an effort to determine the impact of a tail and front fin handicap for the swimming capacity of a stranded porpoise with biting wounds after physical recovery.

DISSERTATIONS

-

SCIENTIFIC PUBLICATIONS

-

PROJECTLEADERS

HWM Hoeijmakers

RESEARCHTHEME

Complex dynamics of fluids

PARTICIPANTS

HWM Hoeijmakers, ETA van der Weide, CH Venner, R Hagmeijer
N van Elk, E Everaerts

COOPERATIONS

Stichting SOS Dolfijn

FUNDED

| | |
|--------------|-------|
| UT | |
| University | 100 % |
| FOM | - |
| STW | - |
| NWO Other | - |
| Industry | - |
| TNO | - |
| GTI | - |
| EU | - |
| Scholarships | - |

START OF THE PROJECT

2012

INFORMATION

HWM Hoeijmakers

053 489 4838

h.w.m.hoeijmakers@utwente.nl



Prof.dr.ir. ThH van der Meer

The research activities of the Thermal Engineering Group mainly concentrate on thermal conversion processes for industrial applications from the disciplines thermodynamics, transport phenomena and fluid mechanics. The research aims at an increasing use of renewable fuels, and at a more efficient and clean utilization of fossil fuels. The projects are organized around three central themes: thermal conversion processes of fuels, turbulent gaseous combustion and thermo-acoustics, and instationary heat transfer.

The research theme thermal conversion processes of fuels is part of the research programme of the OSPT (research school on process technology)

The research theme Turbulent gaseous combustion and thermo-acoustics is related to questions on ignition, extinction, flame stability, pollutant formation, combustion noise and its interaction with the combustion chamber structure. Numerical models are developed (within CFX), and experimental research is done like flow visualisation, acoustic measurements and laser diagnostics like laser induced fluorescence and Ramen/Rayleigh spectroscopy for the in-flame measurements of temperature and species concentrations. the underlying physical-chemical processes. Currently a large EU-project, named LIMOUSINE, with three PhD's and a post doc is ongoing on the topic of thermo-acoustics in gas turbines. Next there are several projects within the STW perspective program Clean Combustion Concepts.

The research theme "instationary heat transfer" is related to heat transfer in piston compressors, a pulsed compression reactor and new materials for enhanced heat transfer in regenerators and heat exchangers based on carbon nano-fibers attached to the heat transfer surface.

THE SOUND SOLUTION FOR SMALL SCALE RESIDENTIAL ENERGY CONVERSION

PROJECT AIM

As efficient usage of resources becomes more and more important because of their finiteness, one way to efficiently use energy is micro combined heat and power generation (micro-CHP). Therefore, Stirling engines raised interest for the domestic use of micro-CHP in recent years. Despite the promise of high efficiency due to the underlying Stirling cycle, these engines often have reliability problems because of their numerous moving parts. The engine under investigation makes use of a thermodynamic cycle similar to Stirling, but with less moving parts, therefore having a much higher reliability. Thus, we focus on the optimization of a thermoacoustic engine for application within a micro-CHP appliance.

PROGRESS

The work on the simulation and optimization of jet pumps has been continued. The influence of geometric parameters on the jet pump performance is investigated using CFD simulations and various flow regimes are distinguished as shown in Figure 1. A preliminary experimental validation has been carried out and this will be continued in the near future. Additionally, another component of the thermoacoustic engine is modeled with CFD: the thermal buffer tube. The acoustic streaming inside of the thermal buffer tube is investigated, as it is responsible for heat losses. The streaming patterns are revealed and by adapting the wall boundary conditions, the impact of the viscous and the thermal effects on the streaming patterns are distinguished from each other.

DISSERTATIONS

-

SCIENTIFIC PUBLICATIONS

1. Bühler, S., Wilcox, D., Oosterhuis, J. P., and Van der Meer, T. H. (2014). "Thermal entrance effects in a thermoacoustic stacked screen regenerator," Proc. 15th Int. Heat Transf. Conf., 1–9.
2. Oosterhuis, J. P., Bühler, S., Wilcox, D., and Van der Meer, T. H. (2014). "Computational fluid dynamics analysis of the oscillatory flow in a jet pump: the influence of taper angle," 9th PAMIR Int. Conf., Riga, 391–395.
3. Bühler, S., Wilcox, D., Oosterhuis, J. P., and Van der Meer, T. H. (2014). "Mean temperature profile at the entrance of a thermoacoustic stacked heat exchanger," 9th PAMIR Int. Conf., Riga, 407–411.

Instantaneous vorticity fields of four different flow regimes around the jet pump

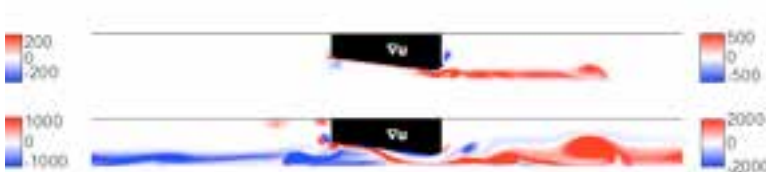

PROJECT LEADERS

TH van der Meer

RESEARCH THEME

Complex dynamics of fluids

PARTICIPANTS

S Bühler, JP Oosterhuis

COOPERATIONS

-

FUNDED

Agentschap NL

University 60 %

FOM -

STW -

NWO Other -

Industry 40 %

TNO -

GTI -

EU -

Scholarships -

START OF THE PROJECT

2011

INFORMATION

TH van der Meer

053 489 2562

t.h.vandermeer@utwente.nl

COMBUSTION MODELING OF COMPLEX 3D HEAT EXCHANGER GEOMETRIES AND SYSTEMATIC DESIGN OPTIMIZATION

PROJECT LEADERS

ThH van der Meer

RESEARCH THEME

Mathematical and computational methods for fluid flow analysis

PARTICIPANTS

Mahening Citra Vidya

COOPERATIONS

Bosch Thermotechnology

FUNDED

| | |
|--------------|-------|
| University | - |
| FOM | - |
| STW | - |
| NWO Other | - |
| Industry | 100 % |
| TNO | - |
| GTI | - |
| EU | - |
| Scholarships | - |

START OF THE PROJECT

2014

INFORMATION

Mahening Citra Vidya
06 29921458
m.c.vidya@utwente.nl

PROJECT AIM

This project aims to investigate a combustion model that can be used to estimate emission values (CO, NOx) in complex 3D geometries. This model will be implemented to improve the current pin-fin heat exchanger by a systematic optimization. The combustion model will then be developed so that not only the emission characteristic but also performance factors are optimized.

PROGRESS

Currently possible optimization methods are investigated. Literature study is done to know the state of the art of the pin-fin heat exchanger and the models for complex geometries. A simple model of a flow around circular cylinder with heat transfer are currently developed in order to get familiar with the computational software and to do the parameter study.

DISSERTATIONS

-

SCIENTIFIC PUBLICATIONS

-

COPA-GT : COUPLED PARALLEL SIMULATION OF GAS TURBINES

PROJECT AIM

Until now, gas turbines have been designed following individual pathways for each component and each physical phenomenon. Nevertheless, the behavior of the individual components can be very different from their behavior when mounted together in an engine. To overcome this disadvantage, the numerical simulation of the entire engine with all physics involved is a key element for scientific progress and innovation. Developing numerical tools and methodologies to simulate the entire gas turbine with all physical effects is a new challenge and the overall scientific objective of the COPA-GT project.

PROGRESS

In the project European wide 13 PhD students and 5 Post Docs work under coordination of CERFACS in Toulouse. At the UT 3 PhD students are active. The project task of S. Gövert focuses on modelling fluid structure interaction (FSI) in gas turbine combustors as embedded in full engine computations. In the first year, FSI simulations of the Limousine combustor have been performed using the ANSYS simulation environment. Due to limitations in customization and parallelization, the ALYA multiphysics code (developed at the Barcelona Supercomputing Center) has been chosen as an alternative tool. An advancement of the CFI combustion model has been implemented and validated for premixed flames. In a next step, the model formulation will be extended to non-premixed configurations and translated to a fully compressible framework. Finally, FSI simulations of academic and industry type combustors are planned using the developed simulation framework.

DISSERTATIONS

-

SCIENTIFIC PUBLICATIONS

1. Gövert, S., Mira, D., Vazquez, M., Houzeaux, G. and Kok, J.B.W., 2014. "Turbulent combustion modeling of a confined premixed methane/air jet flame using tabulated chemistry". In 12th International Conference on Combustion and Energy Utilization (12ICCEU), Lancaster, UK, September 29 – October 3.

PROJECT LEADERS

JBW Kok

RESEARCH THEME

Mathematical and computational methods for fluid flow analysis

PARTICIPANTS

S Gövert, JBW Kok

COOPERATIONS

CERFACS, RWTH Aachen University, Von Karman Institute, Loughborough University, Turbomeca, Siemens, Barcelona Supercomputing Center, Jülich computational center, Bull, Ansys.

FUNDED

| | |
|---|-------|
| European Union Marie Curie ITN University | - |
| FOM | - |
| STW | - |
| NWO Other | - |
| Industry | - |
| TNO | - |
| GTI | - |
| EU Scholarships | 100 % |

START OF THE PROJECT

2012

INFORMATION

JBW Kok

053 489 2582

j.b.w.kok@utwente.nl

www.thw.ctw.utwente.nl/

COPA-GT (COUPLED PARALLEL SIMULATION OF GAS TURBINES) SPRAY COMBUSTION

PROJECT LEADERS

JBW Kok

RESEARCH THEME

Mathematical and computational methods for fluid flow analysis

PARTICIPANTS

V Fratalocchi, JBW Kok

COOPERATIONS

CERFACS, RWTH Aachen University, Von Karman Institute, Loughborough University, Turbomeca, Siemens, Barcelona Supercomputing Center, Jülich computational center, Bull, Ansys

FUNDED

| | |
|--------------------------------|-------|
| European Union Marie Curie ITN | |
| University | - |
| FOM | - |
| STW | - |
| NWO Other | - |
| Industry | - |
| TNO | - |
| GTI | - |
| EU | 100 % |
| Scholarships | - |

START OF THE PROJECT

2012

INFORMATION

JBW Kok

053 489 2582

j.b.w.kok@utwente.nl

PROJECT AIM

The numerical simulation of the entire engine with all physics involved is a key element for scientific progress and innovation. Developing numerical tools and methodologies to simulate the entire gas turbine with multiple physical effects is a new challenge and the overall scientific objective of the COPA-GT project. In this task of the project numerical models are developed for spray evolution, evaporation, mixing and turbulent combustion. Targeted is transient behaviour of spray combustion and coupling to acoustics. The models are optimized for large scale parallel computation with embedding in full engine models.

PROGRESS

Numerical simulations were performed with ANSYS on an acoustically forced spray flame. The influence of the slip velocity and the initial diameter of the droplets were investigated, at high and low frequencies. The forcing leads to a considerable speed up of the combustion rate, but the driving mechanisms are different at low and high frequencies. The liquid dispersion is highly perturbed at low frequency and the stretching of the flame reveals high temperature fluctuations, due to the entrainment of hot gas from the pilot. At high frequency both the Eulerian and the Lagrangian field are little affected by the acoustic wave but the increase of the mean temperature enhances the evaporation rate.

DISSERTATIONS

-

SCIENTIFIC PUBLICATIONS

1. Fratalocchi, V. Kok, J.B.W., Modelling of the dynamics interaction between a reacting spray and an acoustic field in a turbulent combustor. , proc. 21th Int. Congr. Sound and Vibration, Beijing 13-17 July 2014, ISBN, 2014.

LIMOUSINE : LIMIT CYCLES OF PRESSURE OSCILLATIONS IN GAS TURBINE COMBUSTORS

PROJECT AIM

LIMOUSINE aims at the development of numerical tools to predict the chain of events leading to mechanical failure of gas turbine combustors due to limit cycles of low frequency pressure oscillations. Explored is the interaction and the feed back mechanisms between combustion dynamics, acoustics, aerodynamics and structural vibration. Essential is that not only the operating points with linear instability are identified. But also the nonlinear mechanisms leading to amplitude saturation.

PROGRESS

The project task of M.Shahi involves numerical simulations of combustion instabilities in a laboratory scale combustor (both self-excited and induced oscillations). In this task PhD fellow is looking for ways to accurately predict the phenomenon. The work consists of modelling the combustor, looking at the pressure oscillations and liner vibration, coupling between the fluid and structure, coupling between the flame and the structure by means of conjugated heat transfer modelling and finally validations based on experimental findings. The work is done very close with the experimentalists to get the desired data sets to validate the models.

DISSERTATIONS

1. Shahi, Mina, Modeling of complex physics & combustion dynamics in a combustor with a partially premixed turbulent flame, 2014.

SCIENTIFIC PUBLICATIONS

1. Shahi, Mina; Kok, Jim B.W.; Roman Casado, J.C.; Pozarlik, Arthur K., Assessment of thermoacoustic instabilities in a partially premixed model combustor using URANS approach, Applied thermal engineering, Vol. 71, p.276-290. ISSN 1359-4311, 2014.
2. Shahi, M.; Kok, J.B.W.; Pozarlik, A.K.; Roman Casado, J.C.; Sponfeldner, T., Sensitivity of the Numerical Prediction of Turbulent Combustion Dynamics in the LIMOUSINE Combustor, Journal of engineering for gas turbines and power, Vol. 136. ISSN 0742-4795, 2014.
3. Mina Shahi, Jim.B.W.Kok,J.C. Roman Casado, Artur.K.Pozarlik , Study of unsteady heat transfer as a key parameter to characterize limit cycle of high amplitude pressure oscillations, GT2014-26311, Proc ASME Turbo Techn Conf, Dusseldorf, 2014.

PROJECT LEADERS

JBW Kok

RESEARCH THEME

Mathematical and computational methods for fluid flow analysis

PARTICIPANTS

M Shahi, JBW Kok, ThH van der Meer

COOPERATIONS

Project in cooperation with DLR, CERFACS, Imperial College, Keele University, University of Zaragoza, University of Brno, Siemens Muelheim, Ifta Muenchen, Ansys Abingdon

FUNDED

Partially with European union:

Marie Curie Initial Training network program

| | |
|--------------|-------|
| University | - |
| FOM | - |
| STW | - |
| NWO Other | - |
| Industry | - |
| TNO | - |
| GTI | - |
| EU | 100 % |
| Scholarships | - |

START OF THE PROJECT

2011

INFORMATION

JBW Kok

053 489 2582

j.b.w.kok@utwente.nl

www.thw.ctw.utwente.nl

PROJECT LEADERS

ThH van der Meer

RESEARCH THEME

Complex dynamics of fluids

PARTICIPANTS

TJ Taha, ThH van der Meer

COOPERATIONS

ECN

FUNDED

EL&I

University -

FOM -

STW -

NWO Other -

Industry 100 %

TNO -

GTI -

EU -

Scholarships -

START OF THE PROJECT

2010

INFORMATION

TJ Taha

053 489 2559

t.j.taha@ctw.utwente.nl

PROJECT AIM

The aim of the project is to study in depth the effect of carbon nano-fibers deposited on heat transfer surface for heat transfer to/ from a fluid. At first materials will be synthesized in a very controlled manner by growing carbon nano-fibers with in situ measurements of the weight increase and the heat of reaction of the synthesis process. Heat transfer to/from the new materials will be determined experimentally. Structural and morphological effect of the CNFs on heat transfer will be studied and optimal configuration will be derived. A production facility for the synthesis of carbon nano-fibers will be designed and built.

PROGRESS

Synthesis of vertically aligned CNTs was obtained by depositing 10nm Ta + 5nm Fe on silicon chip with integrated thin film 180nm Pt heat on 10nm Ta adhesive layer. A number of different samples with different morphological and topological surfaces were tested. Two setup orientation are chosen to measure the structural influence of the VACNFs on heat transfer performance. (1) Micro-channel heat transfer measurement setup was designed and produced to measure the structural influence of CNTs on silicon chip. To accurately quantify the conjugated heat transfer from the heater to the setup, the heat transfer measurement is supported by numerical simulation using Comsol. (2) Impinging jet flow setup was designed and built. Both heat transfer and pressure drop measurements were conducted using the two setup configuration.

DISSERTATIONS

-

SCIENTIFIC PUBLICATIONS

-

ULRICO : ULTRA RICH COMBUSTION OF HYDROCARBONS AND SOOT FORMATION

PROJECT AIM

This project generates knowledge needed in the design and operation of ultra clean, efficient and reliable natural gas partial combustion systems to produce syngas. Computational fluid dynamics modeling is applied to predict fuel rich turbulent combustion at elevated pressure. The modeling involves prediction of major and minor chemical species, radiative heat loss and soot precursor species. These are linked to a soot formation and transport model for particle size distribution. Multiple combustion regimes are explored. The CFD model is validated by 6 bar/300 kW laboratory tests, including gas composition, soot particle size, nature and number density.

PROGRESS

A MILD-combustor for ultra rich combustion of natural gas has been designed and manufactured. The designed combustor was numerically simulated and analyzed with CHEMKIN PSR and ANSYS CFX. The simulations show that the formation of acetylene, the most important soot precursor, was reduced and that the output of syngas was improved. Experiments with a premixed swirled combustor were performed. The gas composition and soot particle size distribution were measured for different operating conditions. The soot particle size distribution was parameterized in terms of 2 control scalars and used for improvement of the custom soot formation model.

DISSERTATIONS

1. M. Woolderink, Soot formation in ultra-rich turbulent combustion of natural gas at elevated pressure, 2014.

SCIENTIFIC PUBLICATIONS

-

PROJECT LEADERS

JBW Kok

RESEARCH THEME

Mathematical and computational methods for fluid flow analysis

PARTICIPANTS

MHF Woolderink, JBW Kok, ThH van der Meer

COOPERATIONS

Shell Global Solutions, Amsterdam.
Aalborg Industries, Nijmegen.
Automotive Technology Centre, Eindhoven. DAF Trucks, Eindhoven.
ANSYS UK, Abingdon, UK.

FUNDED

STW, Shell Global Solutions
Amsterdam, ANSYS UK
University -
FOM -
STW 75 %
NWO Other -
Industry 25 %
TNO -
GTI -
EU -
Scholarships -

START OF THE PROJECT

2009

INFORMATION

JBW Kok
053 489 2582
j.b.w.kok@utwente.nl
www.utwente.nl/ctw/thw



Prof.dr.rer.nat. S Luding

The Multi Scale Mechanics group (MSM) is part of the cluster Fluid and Solid Mechanics and Engineering in the Faculty of Engineering Technology at the University of Twente, as well as member of the research institute MESA+. The group studies the static and dynamic properties of dry and wet granular materials, as well as fluids and solids in general.

Examples include segregation versus mixing; sticky powders; wave-propagation in disordered media; solid concrete; avalanche flows of grains, snow or soil; composite and self-healing materials. A wide range of length and time scales characterizes the relevant physical processes in these systems. At the microscopic level, the deformation behavior of the granule/atom/molecule with contact/interaction physics on the nano-meter scale determines the dynamics and statics of the particles. The mesoscopic level sees the collective motions of the individual granules involving e.g. shear localization and wave-propagation. Finally, on the macroscopic level, a granular material behaves as a fluid with complex flow behavior involving anisotropy. At each length scale, the question arises how the mechanics at that level is determined by the properties of the underlying level, and how, in turn, the current level affects the previous and the next levels.

Theory and experiments, supported by advanced numerical simulations, are aimed at understanding the various, multiple scales/levels and their intricate couplings. Micro-Macro theory is one way to predict and describe this hierarchy. By combining numerical simulations with theory and experiments, the Multi Scale Mechanics group is developing a comprehensive understanding of the properties of granular materials, fluids and solids. The group is also interested in mesoscale simulations (on intermediate level) of particles with attractive interactions, to study aggregation of self-assembly of patchy colloidal particles and proteins on the macromolecular scale, or to model asphalt on the stone-bitumen scale. Mesoscopic models use the small-scale information to formulate effective contact laws and allow thus to simulate much larger systems than possible with (too) detailed micro-models.

Besides improving our fundamental understanding of fluids and solids, the results find applications in the improvement of industrial processing procedures for granular matter, as well as contributing to the design of advanced materials, processes and equipment.

MODELING OF LONG-RANGE INTERACTION FORCES AND CLUSTERING PHASE DIAGRAM

PROJECT AIM

The objective of this project is to understand the interactions between particles in granular systems from discrete element simulations. The aim is to model long range attractive / repulsive interactions in homogeneous and inhomogeneous (cooling) systems and to provide a phase diagram for the transition from homogeneous to inhomogeneous in the phase space of dissipation and strength of the interaction potential (normalized by the granular temperature, which sets the fluctuation energy scale).

PROGRESS

In the last year, we published the study on the clustering phase diagram for granules with long-range interactions. Astonishingly good agreement is found between simulations and a mean field theory, where only the energy dissipation term is modified to account for both repulsive or attractive non-contact interactions. Attractive potentials enhance cooling and structure formation (clustering), whereas repulsive potentials reduce it, as intuition suggests. The system evolution is controlled by dissipation and the non-contact potential strength. When the latter is small, the classical homogeneous cooling state is found; if effective dissipation is strong enough, structure formation proceeds, before (in the repulsive case) non-contact forces get strong enough to undo the clustering (due to ongoing dissipation). This can be cast into a phase diagram where the system changes with time, which leaves open many challenges for future research.

DISSERTATIONS

-

SCIENTIFIC PUBLICATIONS

1. S. Gonzalez, A. R. Thornton, and S. Luding,

Free Cooling Phase-Diagram of

Hard-Spheres with Short- and Long-Range Interactions, *Europ. Phys. J.* -

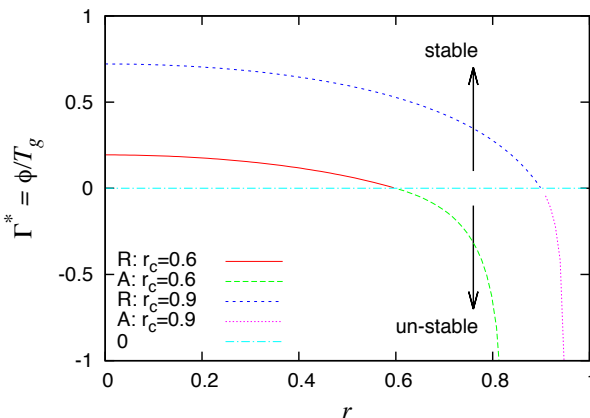

PROJECT LEADERS

S Luding

RESEARCH THEME

Complex structures of fluids

PARTICIPANTS

S Gonzalez Briones, A Thornton

COOPERATIONS

-

FUNDED

FOM

University -

FOM 100 %

STW -

NWO Other -

Industry -

TNO -

GTI -

EU -

Scholarships -

START OF THE PROJECT

2008

INFORMATION

S Luding

s.luding@utwente.nl

Phase diagram in dissipation ($1-r^2$) and potential strength parameter space, where the potential energy is scaled by the fluctuation kinetic energy T_g . Lines indicate the transition to inhomogeneity (for different dissipation strength) and the arrows indicate the evolution of different systems with attractive or repulsive interactions.

MESOSCALE SIMULATION OF MULTIPHASE FLUID-SOLID SYSTEMS USING A COUPLED SPH-DEM METHOD

PROJECT LEADERS

S Luding

RESEARCH THEME

Mathematical and computational methods for fluid flow analysis

PARTICIPANTS

G Raso, S Luding, M Robinson, M Ramaioli, A Di Renzo, F P Di Maio

COOPERATIONS

University of Twente, Università della Calabria, University of Oxford

FUNDED

| | |
|--------------|-------|
| EU | |
| University | - |
| FOM | - |
| STW | - |
| NWO Other | - |
| Industry | - |
| TNO | - |
| GTI | - |
| EU | 100 % |
| Scholarships | - |

START OF THE PROJECT

2014

INFORMATION

G Raso
g.raso@utwente.nl

PROJECT AIM

The goal of this project is the validation of a numerical technique for the simulation of multi-phase flow of a fluid-solid suspension. The peculiar feature of this method lies in the mesh-free nature of the fluid simulation: this method may be applied in many cases where the mesh-based methods are not applicable, for example in the solution of systems with free surfaces or deformable boundaries. Several sedimentation test cases have been implemented, from single homogenous monodisperse and bidisperse suspension. The results of these simulations have been compared with the predictions of models present in the literature with good agreement.

PROGRESS

Three-dimensional numerical simulations of multiphase system using a coupled smoothed particle hydrodynamics (SPH) and discrete elements method (DEM) has been performed. A comparison of the simulations results in term of steady-state velocity, drag force, buoyancy, void fraction with the theoretical predictions obtained from well-known model present in the literature. Good agreement was found in the comparison of the results. The effect of the fluid resolution (ratio between the SPH particle diameter and DEM particle diameter) has been studied, the results suggest that for a specific fluid resolution, a minimum in the error committed by the method exists at about two particle diameters. In the case of bidisperse suspensions a method for the minimization of the error has been suggested, introducing a double smoothing for the calculation of the void fraction of the SPH particles.

DISSERTATIONS

-

SCIENTIFIC PUBLICATIONS

-

PROJECT AIM

Characterization of the connection between the structure of granular media and the signal transmission behavior; understanding the role of contact and micro-structure details on the bulk behavior is important for a general understanding of the physics of such systems. Propagation of stress and energy in granular systems is sensitive to even small amounts of disorder in either mass or the contact network [1]. We numerically and analytically study the effects of random [1] or isolated mass-disorder [2] and anisotropy on the energy transfer and frequency content of propagated signals.

PROGRESS

In the early phase of the project, a convenient one-dimensional system has been employed to quantify the effects of mass-disorder ξ and relate the behavior to localization effects for linear and pre-compressed (non-) linear systems [1]. In the figure below, saturation of disorder is varied and the bulk signal transmission (frequency content) has been plotted for the respective amount of disorder. Such systems are observed to act as low-pass filters, attenuating the higher frequencies through mode localization and backscattering [2].

DISSERTATIONS

1. Erasmus MSc thesis Stefan Emmerich, February 2014, RUBochum, Germany + UTwente, Netherlands

Modelling and Experiments of Ultrasound Propagation in Porous Material: an Application to Bones.

SCIENTIFIC PUBLICATIONS

1. B. P. Lawney, and S. Luding,

PROJECT LEADERS

S Luding, V Magnanimo

RESEARCH THEME

Mathematical and computational methods for fluid flow analysis

PARTICIPANTS

RK Shrivastava, B Lawney

COOPERATIONS

RUBochum, Shell

FUNDED

| | |
|--------------|------|
| FOM, Shell | |
| University | - |
| FOM | 50 % |
| STW | - |
| NWO Other | - |
| Industry | 50 % |
| TNO | - |
| GTI | - |
| EU | - |
| Scholarships | - |

START OF THE PROJECT

2014

INFORMATION

S Luding
s.luding@utwente.nl

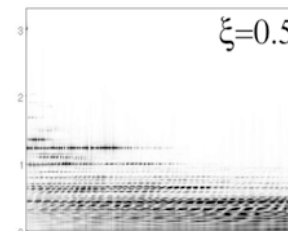
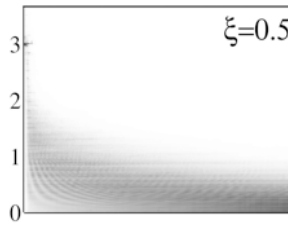
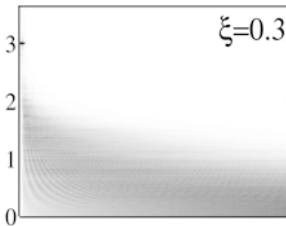

Frequency spectrum versus distance from the source [1] for different magnitudes of disorder, and for ensemble (200 realizations) average (top panel), and single chain realizations (bottom).

PROJECT LEADERS

S Luding, A Thornton

RESEARCH THEME

Complex dynamics of fluids

PARTICIPANTS

MP van Schroyen Lantman

COOPERATIONS

-

FUNDED

STW-NWO VIDI

University -

FOM -

STW -

NWO Other 100 %

Industry -

TNO -

GTI -

EU -

Scholarships -

START OF THE PROJECT

2014

INFORMATION

MP van Schroyen Lantman

053 489 3345

m.p.vanschroyenlantman@
utwente.nl

PROJECT AIM

The goal of this project is to develop open source software that is capable of simulating particles in a fluid on different scales. For meso scale simulations the already existing UTwente open source software packages MercuryDPM and hpGEM will be coupled. On small scales a simple potential flow model will be developed as an extension of the particle code MercuryDPM. The developed software can be applied to various systems, such as, e.g., a rotating drum with fluid or the dispersion of a powder bed by a liquid jet.

PROGRESS

A literature study is currently in progress to determine the best coupling method between MercuryDPM and hpGEM with the application of a rotating drum in mind. The conclusion of this study indicates advantages when implementing a meshless Galerkin method. The simple potential flow model makes use of an analytical solution that has severe complexity issues. The complexity of the numerical form of this analytical solution is now reduced to acceptable levels, however, the computational cost still needs to be reduced.

DISSERTATIONS

-

SCIENTIFIC PUBLICATIONS

-

BRIDGING THE GAP BETWEEN PARTICULATE SYSTEMS AND CONTINUUM THEORY

PROJECT AIM

Modern discrete particle-based models describe the particles in detail, but are of limited value for studying industrial processes and natural phenomena since too many particles are involved. Continuum methods, on the other hand, are readily applied in engineering applications. However, these methods rely on empirical constitutive laws with phenomenological parameters that disregard both the discrete nature of particles and the micro-structure. Micro-macro transition methods are being developed to combine the advantages of discrete and continuum models and thus bridge the gap between particulate systems and continuum theory.

PROGRESS

A novel local constitutive model based on observations from discrete element simulations has been developed for small-scale deformations of a quasi steady bi-axial geometry. The model consists of nonlinear evolution equations for both shear stress and anisotropy during deviatoric (shear) deformations, to model the history dependence, with only four material parameters. Several simulations were performed to test the model's accuracy for various deformation modes, with the goal to find out where improvement is needed. Dynamic particles simulations were compared to static energy minimization methods. The open source code MercuryDPM and its hierarchical neighborhood search algorithm that can deal with strongly different particle sizes were studied, both practically as well as theoretically, and a guideline to use the optimal settings was published.

DISSERTATIONS

-

SCIENTIFIC PUBLICATIONS

1. D. Krijgsman, V. Ogarko, and S. Luding, Optimal parameters for a hierarchical grid data structure for contact detection in arbitrarily polydisperse particle systems, *Comp. Part. Mech* 1, 357-372, 2014.

PROJECT LEADERS

S Luding, V Magnanimo

RESEARCH THEME

Complex structures of fluids

PARTICIPANTS

D Krijgsman

COOPERATIONS

-

FUNDED

NWO-STW VICI

University -

FOM -

STW -

NWO Other 100 %

Industry -

TNO -

GTI -

EU -

Scholarships -

START OF THE PROJECT

2010

INFORMATION

D Krijgsman

053 489 4732

d.krijgsman@utwente.nl

PROJECT LEADERS

S Luding

RESEARCH THEME

Complex dynamics of fluids

PARTICIPANTS

A Thornton, D van der Meer

COOPERATIONS

D. Parker and K. Windows-Yule,
University of Birmingham

S. Rhebergen, University of Oxford

FUNDED

NWO-STW VICI

University -

FOM -

STW -

NWO Other 100 %

Industry -

TNO -

GTI -

EU -

Scholarships -

START OF THE PROJECT

2011

INFORMATION

N Rivas

06 46801577

N.A.Rivas@utwente.nl

www2.msm.ctw.utwente.nl/nrivas/

Different width vibrated systems displaying convection cells (left), horizontal inhomogeneity (middle), and suppressed horizontal structures with interesting vertical dynamics (right).

PROJECT AIM

We apply and compare microscopic and macroscopic numerical and theoretical models for flowing granular matter. Models are applied to a driven granular system, consisting of a vertically shaken narrow box filled with grains. The studied system presents many different inhomogeneous stable states as a function of the energy injection and grain properties and number. We focus on the transitions between the different states and study the influence of finite particle size and low number of particles, which may lead to a better general understanding of the out-of-equilibrium statistical physics behind complex granular systems.

PROGRESS

An experimental study of low-frequency oscillations, a collective semi-periodic movement discovered in the shallow vibrated geometry, was done. This work was realized in collaboration with the University of Birmingham, using Positron Emission Particle Tracking technology. The experiments where successful in reproducing the phenomena. A second experimental verification of the phenomena is currently under way with the Physics of Fluids group of the University of Twente. Furthermore, the granular hydrodynamic equations describing the granular Leidenfrost state were solved in different physical limits, a work done in collaboration with S. Rhebergen from the University of Oxford. This has allowed us to understand better the relevance of each physical process in the transition to convective states. Finally, a novel methodology was developed to study finite-size and finite-number effects on granular systems.

DISSERTATIONS

-

SCIENTIFIC PUBLICATIONS

1. Influence of initial conditions on granular dynamics near the jamming transition. CRK Windows-Yule, AD Rosato, N Rivas, DJ Parker. *New Journal of Physics* 16 (6), 063016.
2. Communication: Structure characterization of hard sphere packings in amorphous and crystalline states. V Ogarko, N Rivas, S Luding. *The Journal of Chemical Physics* 140 (21), 211102.
3. Low-frequency oscillations and convective phenomena in a density-inverted vibrofluidized granular system. CRK Windows-Yule, N Rivas, DJ Parker, AR Thornton. *Physical Review E* 90 (6), 062205.

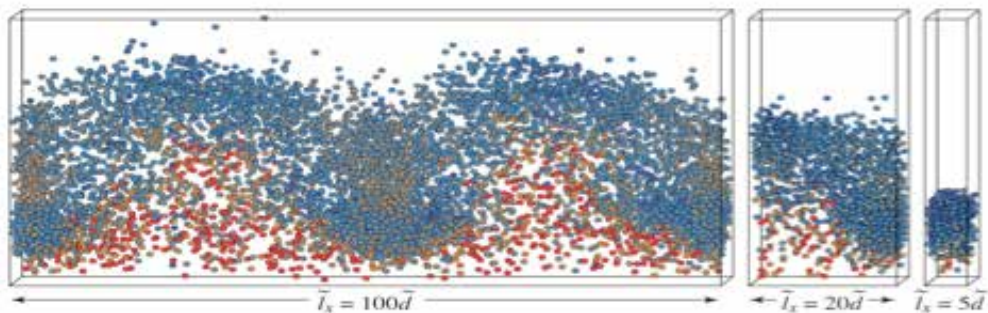

BRIDGING THE GAP BETWEEN PARTICULATE SYSTEMS AND CONTINUUM THEORY

PROJECT AIM

Quasi-static deformations of soft particles and granular materials, have been widely investigated because of their significant importance in industry and science. However, many challenges of describing their macroscopic behaviors still remain. At the microscopic scale, mechanical responses of soft particles are probed as a reconstruction of force-chain networks, where complicated non-affine displacements of particles cause the "recombination" of force-chains. The PDFs in soft particles have practical importance, but only the master equation with the transition rate allows to predict the macroscopic material response based on a mesoscale stochastic theory basis.

PROGRESS

We study the microscopic response of force-chain networks in jammed soft particles to quasi-static isotropic (de)compressions by molecular dynamics simulations. We show that not only contacts but also interparticle gaps between the nearest neighbors must be considered for the stochastic evolution of the PDFs of forces, where the mutual exchange of contacts and interparticle gaps, i.e. opening and closing contacts, are also crucial to the incremental system behavior. By numerically determining the transition rates for all changes of contacts and gaps, we formulate a Master equation for the PDFs of forces, where the insight one gets from the transition rates is striking: The mean change of forces reflects non-affine system response, while their fluctuations obey uncorrelated Gaussian statistics. In contrast, interparticle gaps are reacting mostly affine in average, but imply multi-scale correlations according to a much wider stable distribution function.

DISSERTATIONS

-

SCIENTIFIC PUBLICATIONS

1. K. Saitoh, V. Magnanimo, and S. Luding, "A Master equation for the probability distribution functions of forces in soft particle packings", accepted to Soft Matter 11, 1253-1258, 2015] (DOI: 10.1039/C4SM02452D). On the journal cover (above figure).
2. S. Takada, K. Saitoh, and H. Hayakawa, "Simulation of cohesive fine powders under a plane shear", Phys. Rev. E 90 (2014) 062207.
3. A. Singh, V. Magnanimo, K. Saitoh, and S. Luding, "Effect of cohesion on shear banding in quasistatic granular materials", Phys. Rev. E 90 (2014) 022202.
4. C. Sanli, K. Saitoh, S. Luding, and D. van der Meer, "Collective motion of macroscopic spheres floating on capillary ripples: Dynamic heterogeneity and dynamic criticality", Phys. Rev. E 90 (2014) 033018.

Sketch of the contact network with real (red) and virtual (blue) contacts, before and after (grey) an isotropic deformation, as well as the non-affine deformation field (arrows, lower panel). Macroscopic quantities can be defined as a statistical average in force-chains, e.g. the stress tensor, elastic moduli, and their non-trivial response to quasi-static deformations is governed by the change of the probability distribution function (PDF) of forces.

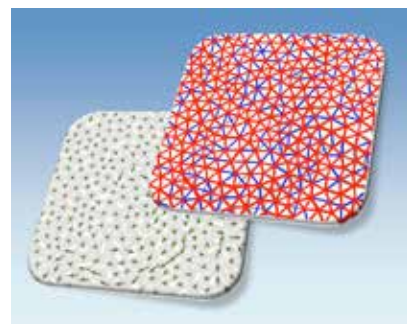

PROJECT LEADERS

S Luding

RESEARCH THEME

Mathematical and computational methods for fluid flow analysis

PARTICIPANTS

K Saitoh

COOPERATIONS

M Sperl (DLR Cologne)

FUNDED

VICI-STW VICI

University -

FOM -

STW -

NWO Other 100 %

Industry -

TNO -

GTI -

EU -

Scholarships -

START OF THE PROJECT

2011

INFORMATION

K Saitoh

053 489 5363

k.saitoh@utwente.nl

www2.msm.ctw.utwente.nl/saitohk/

PROJECT LEADERS

S Luding

RESEARCH THEME

Complex dynamics of fluids

PARTICIPANTS

A Singh, V Magnanimo, K Saitoh

COOPERATIONS

-

FUNDED

NWO-STW VICI

University -

FOM 100 %

STW -

NWO Other -

Industry -

TNO -

GTI -

EU -

Scholarships -

START OF THE PROJECT

2009

INFORMATION

A Singh

053 489 2694

A.Singh@ctw.utwente.nl

PROJECT AIM

Aim is to probe the connections between jamming, shear banding and microstructure in numerical simulations of Brownian and non-Brownian systems with various interaction forces. Particle simulations are used to study the shear banding in a 'split bottom ring shear cell', where a slow quasi-static deformation leads to wide shear bands being formed away from the side walls, which allow to study the local rheology-microstructure relation of dense, slowly sheared granular matter.

PROGRESS

Discrete element simulations are used to study the effect of cohesion and friction on shear banding and force probability distributions (PDFs) in a split-bottom ring shear cell. For low driving rates the velocity profiles are found to collapse to a single function. A dimensionless number, the Bond number (Bo), is defined to quantify the intensity of attractive cohesive forces relative to gravity. We find that Bo acts as a critical parameter in the system: the width of the shear band is independent of cohesion for $Bo < 1$, while the shear band gets wider with increasing cohesion for $Bo > 1$. On the other hand, no strong effect of particle friction on the shear banding is observed. The anisotropy of the force chain network increases with both friction and cohesion. Poor mobility of particles due to strong cohesion affects not only the contact network along the tensile direction, but also the force carried by the contacts along the compressive direction. Simulations reveal striking insights into the symmetry and anisotropy of the force network for both tensile and repulsive forces, see figure.

DISSERTATIONS

1. A. Singh, Micro-macro and rheology in sheared granular matter, PhD thesis, University of Twente, ISBN : 978-90-365-3678-3 <http://doc.utwente.nl/90650/>

SCIENTIFIC PUBLICATIONS

1. A. Singh, V. Magnanimo, and S. Luding, Effect of friction on the force distribution in sheared granular materials, in: NUMGE 2014, M. A. Hicks, R. B. J. Brinkgreve, and A. Rohe (Eds.),

Interparticle forces in the mid layer of the granular bed, for a quarter segment of the ring shear cell. The dotted line shows the center of the shear band. The top two images show particle pairs exerting a repulsive net force, the two bottom images show pairs exerting an attractive net force (grey: below average strength, red/blue: above average strength). Left and right correspond to low and high cohesion, relatively. Note that both the attractive and the repulsive forces increase with increasing cohesion.

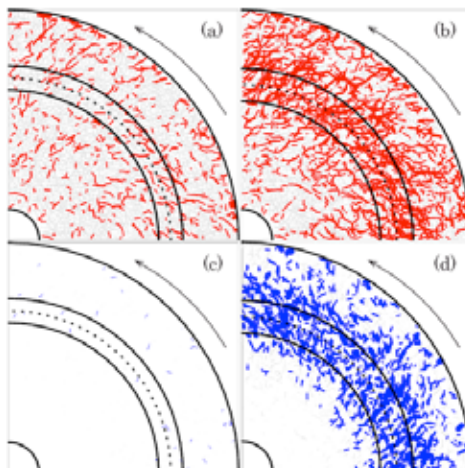

MULTI-SCALE DYNAMIC COUPLING OF FEM/DEM FOR FLUID-PARTICLE INTERACTIONS

PROJECT AIM

Aim of this project was to develop a multi-scale monolithic computational framework for modeling fluid-particle interactions for industrially relevant problems, e.g. for flow through porous media and fluidized beds. The key basic datastructure of this framework is a Delaunay triangulation that is used for both as efficient contact detection tool for moving particles and for solving flow using an unstructured finite element method.

PROGRESS

A two-way fluid-particle coupling on an unstructured mesoscopically coarse mesh was presented. A (higher order) finite element method (FEM) on the moving mesh for the fluid is combined with a soft sphere discrete element method (DEM) for the particles. The novel feature of the proposed scheme is that the FEM mesh is a dynamic Delaunay triangulation based on the positions of the moving particles. Thus, the mesh can be multipurpose: it provides (i) a framework for the discretization of the Navier-Stokes equations, (ii) a simple tool for detecting contacts between moving particles, (iii) a basis for coarse graining or up-scaling and (iv) coupling with other physical fields (viz. temperature, electromagnetic, etc.). This approach is suitable for a wide range of dilute and dense particulate flows, since the mesh resolution adapts with particle density in a given region. Two-way momentum exchange is implemented using semi-empirical drag laws and the method is validated with test cases.

DISSERTATIONS

-

SCIENTIFIC PUBLICATIONS

1. J. Harting, S. Frijters, M. Ramaioli, M. Robinson, D.E. Wolf, and S. Luding,
Recent advances in the simulation of particle-laden flows,
[Europ. Phys. J. - Special Topics 223(11), 2253-2267, 2014.

PROJECT LEADERS

S Luding

RESEARCH THEME

Mathematical and computational methods for fluid flow analysis

PARTICIPANTS

S Srivastava, K Yazdchi

COOPERATIONS

Boehringer Ingelheim (Dr. Wachtel)

FUNDED

STW-MUST (Project No. 10120)

University -

FOM -

STW 80 %

NWO Other -

Industry 20 %

TNO -

GTI -

EU -

Scholarships -

START OF THE PROJECT

2008

INFORMATION

S Luding

s.luding@utwente.nl

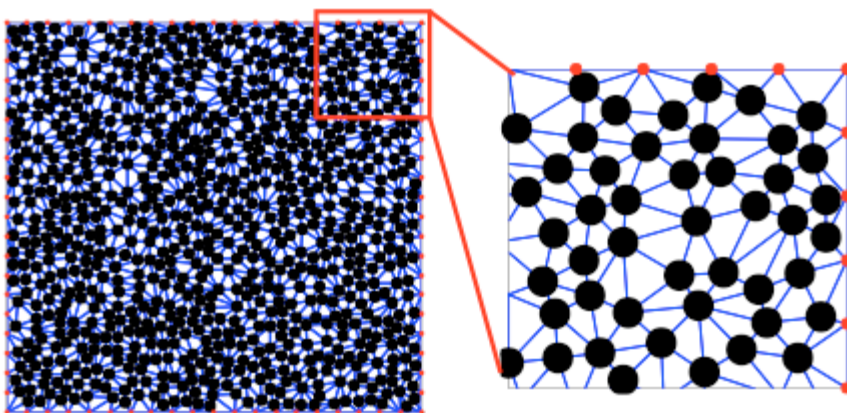

Sketch of the DEM-FEM coupled model, with zoom into the upper right part. The grid is attached to the particles and moves with them, while the fluid flow is solved on the grid.

HYDRODYNAMIC THEORY OF WET PARTICLE SYSTEMS: MODELING, SIMULATION AND VALIDATION BASED ON MICROSCOPIC AND MACROSCOPIC DESCRIPTIONS

PROJECT LEADERS

S Luding, T Weinhart

RESEARCH THEME

Mathematical and computational methods for granular material flow analysis

PARTICIPANTS

S Roy

COOPERATIONS

R Schwarze (TU Freiberg), S Turek (TU Dortmund), A Gladky (TU Freiberg), A Ouazzi (TU Dortmund), S Mandal (TU Dortmund)

FUNDED

STW (UTwente) and DFG (joint project with TU Dortmund and TU Freiberg)

University -

FOM -

STW 50 %

NWO Other -

Industry 50 %

TNO -

GTI -

EU -

Scholarships -

START OF THE PROJECT

2013

INFORMATION

S Luding

053 489 4212

s.luding@utwente.nl

PROJECT AIM

The objective of the project is to develop a description of the flow of partially wet granular materials, based on detailed knowledge of the links between micro-scale and macro-scale material parameters. The main aims of the project are the formulation of suitable constitutive equations for the stress-strain relations of wet granular materials, the calibration of the parameters in these constitutive equations with Discrete Element Method (DEM) simulations, the validation of the micro-macro transition with data from experiments on wet granular materials, and the development of more efficient macroscopic simulation tools to model large-scale experiments.

PROGRESS

The cylindrical split-bottom Couette cell, see figure, has proven a convenient system to study the flow behavior of dry granular materials at the microscopic and macroscopic level. In the current project, the DEM simulations are extended with an appropriate liquid capillary bridge model between the particles. The micro-macro behavior of partially wet granular materials has been analyzed [1] and a correlation is developed.

We also use a simplified contact model, which shows the same macroscopic behavior as the more complex liquid capillary bridge model. By comparing the two models, we show that the adhesion energy and the maximum adhesion force are the dominant microscopic control parameters. Another challenge is to understand the microscopic origin of the force network for wet cohesive system, which is subject of future work.

DISSERTATIONS

-

SCIENTIFIC PUBLICATIONS

1. S. Roy, S. Luding, and T. Weinhart, Towards hydrodynamic simulations of wet particle systems, World Congress on Particle Technology 7, accepted by Procedia Engineering, DOI: 10.1016/j.proeng.2015.01.288.

Snapshots of the quarter-system (left: cross-section, right: top view) showing the angular velocities (color coded with blue as low velocity and red as high velocity) of 37000 particles confined between a stationary inner cylinder and a concentric rotating outer cylinder (with part of the bottom). The localized shear-band is indicated by green color.

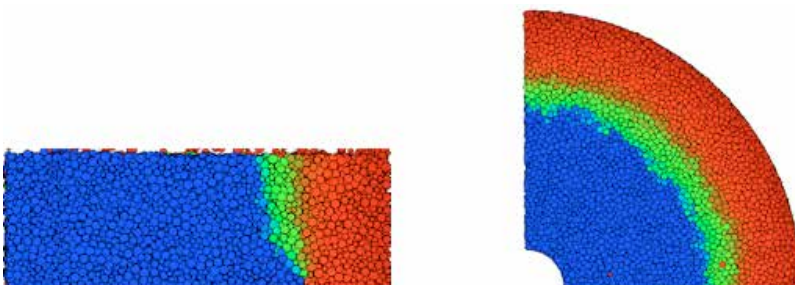

SINTERING – MODELING OF PRESSURE-, TEMPERATURE-, OR TIME-DEPENDENT CONTACTS

PROJECT AIM

The goal of this project is to model particles in contact, in particular for particles that melt and sinter when heated and thereby lose their identity. For this, temperature- and pressure-dependent contact models have to be developed in parallel to contact-measurements in the group of dr. Kappl (Mainz). The resulting many- particle simulation model will be experimentally validated against bulk experiments. This model will be used for the micro-macro transition: based on the microscopic contact-mechanics and –physics between particles, deduce constitutive relations for the macroscopic description of sintered materials.

PROGRESS

Rolling, sliding and torsion properties of individual silica microspheres have been investigated in collaboration with dr. T. Staedler (Siegen), [1], see Fig 1. The resulting microscopic contact laws are currently validated with bulk experiments in the μ -shear tester in collaboration with L. Torbahn (Braunschweig).

Contact modeling and simulations of sintered material is in progress, in collaboration with dr. M. Kappl (Mainz), where sintering of micron-sized particles is studied using Atomic Force Microscopy.

A local and objective description of the stress tensor under shear was developed both for molecular and granular flows. The method was applied to describe segregation mechanisms in bidispersed granular flows [2].

The micro-macro transition methods described above are implemented in MercuryDPM. MercuryDPM is an open-source code for particle simulations developed within the Multi Scale Mechanics group and is actively developed by Thomas Weinhart, Anthony Thornton and Dinant Krijgsman. It is a very versatile, easily understandable code, and thus enables the transition of scientific knowledge to users in industry and academia.

DISSERTATIONS

-

SCIENTIFIC PUBLICATIONS

1. R. Fuchs, T. Weinhart, J. Meyer, H. Zhuang, T. Staedler, X. Jiang and S. Luding, Rolling, sliding & torsion of micron-sized silica particles - Experimental, numerical and theoretical analysis. *Granular Matter* 16, 281 (2014).
2. Windows-Yule, K.; Weinhart, T.; Parker, D.J.; Thornton, A.R., The influence of thermal convection on density segregation in a vibrated binary granular system, *Physical Review E* (2014).
3. Windows-Yule, K.; Weinhart, T.; Parker, D.J.; Thornton, A.R. Effects of system packing on the segregation behaviours of granular systems, *Physics Review Letters* (2014).

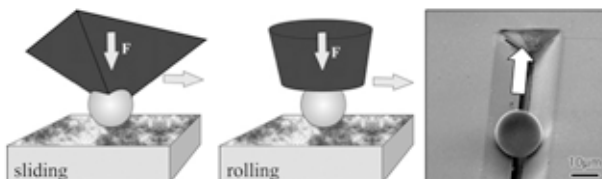

Three modes of motion are measured on micron-sized particles in the nanoindenter setup: (Left) pure sliding, (Centre) pure rolling, (Right) combined rolling-torsion; the latter uses the novel rail setup.

PROJECT LEADERS

S Luding

RESEARCH THEME

Mathematical and computational methods for fluid flow analysis

PARTICIPANTS

T Weinhart

COOPERATIONS

M Kappl (MPIP Mainz), J Tomas (Uni Magdeburg), T Staedler (Uni Siegen)

FUNDED

| | |
|--------------|-------|
| DFG | |
| University | - |
| FOM | - |
| STW | - |
| NWO Other | - |
| Industry | 100 % |
| TNO | - |
| GTI | - |
| EU | - |
| Scholarships | - |

START OF THE PROJECT

2011

INFORMATION

S Luding
053 489 4212
s.luding@utwente.nl

DETECTION AND GUIDANCE OF NANOPARTICLES FOR ENHANCED OIL RECOVERY

PROJECT LEADERS

S Luding, H Steeb, J Harting

RESEARCH THEME

Complex dynamics of fluids

PARTICIPANTS

I Guven

COOPERATIONS

Shell-FOM IPP

FUNDED

| | |
|---------------|------|
| Shell-FOM IPP | |
| University | - |
| FOM | 50 % |
| STW | - |
| NWO Other | - |
| Industry | 50 % |
| TNO | - |
| GTI | - |
| EU | - |
| Scholarships | - |

START OF THE PROJECT

2010

INFORMATION

H Steeb
+49(0)234 32 23080
holger.steeb@rub.de

S Luding
053 489 4212
s.luding@utwente.nl

PROJECT AIM

The project aims to investigate the behavior of oil-water mixtures in porous media by means of combined electromagnetic-acoustic wave propagation. The emulsion will be stabilized by amphiphilic ferro-magnetic nano-particles. The goals are to establish whether these particles are a suitable alternative to current enhanced oil recovery techniques, and whether pulsed electromagnetic fields can be used to guide the particles to regions of interest.

PROGRESS

The focus in the third year of the project was the analysis and understanding of the ultrasound experiments of water-saturated sintered samples with different particle diameters and degree of polydispersity. The propagating acoustic wave is very sensitive to the underlying micro- and macrostructure of the fluid-saturated bulk medium, and thus can be used to characterize the samples. To understand the ultrasound propagation in such systems, the samples were analyzed on different length-scales using μ CT-scans. Depending on used glass beads and sintering treatment, the produced samples showed different microscopic and macroscopic features, which highly influence the acoustical wave propagation. Figure 1 (left) shows exemplarily the received time signals of a sample with bead diameters between 1.0 and 1.2 mm. The piezoelectric transmitter was excited with sinus-burst-signal at 1MHz. The received time signal basically consists of a low-frequency primary coherent pulse, which arrives at the leading edge of the received signals and a high-frequency incoherent part composed of scattered waves, which propagate slower as their travelling path is not the shortest one. The coherent pulse with large amplitudes describes the macroscopic features of the propagating medium, and corresponds to the fast P-wave, which mainly arises from the inertial coupling of the pore fluid and solid matrix, while the incoherent part is composed of multiple-scattered waves, which are highly sensitive to the underlying microstructure. In Figure 1 (right), the normalized amplitude spectrum of the sample in comparison with the spectrum of the reference measurement in water shows that the porous sample acts as a low-pass filter, which allows low-frequency waves to pass through sample whereas the high-frequency components are filtered out. The peaks of the sample measurement are shifted to lower frequencies compared to the spectrum of water measurement.

DISSERTATIONS

-

SCIENTIFIC PUBLICATIONS

1. Hydraulic properties of sintered glass bead systems, I. Gueven, S. Frijters, H. Steeb, S. Luding and J. Harting, in revision.
2. Wave propagation in sintered porous glass beads systems: Low-frequency range, I. Gueven, S. Luding, H. Steeb, in preparation, The Journal of the acoustical society of America (JASA).

Received time signal (left) with corresponding amplitude spectrum (right) of a water-saturated sample with particle diameters between 1.0 and 1.2 mm.

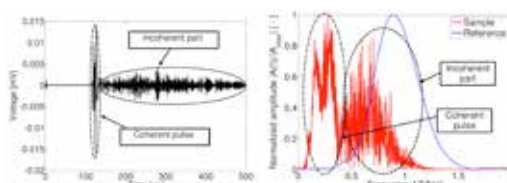

POLYDISPERSED GRANULAR FLOWS OVER INCLINED CHANNELS

PROJECT AIM

The primary goal of the project is to investigate dry polydispersed, both in size and density, granular flows over inclined channels including segregation phenomena. For this purpose, we develop a macro-scale Discountinuous Galerkin Finite Element Method (DGFEM) granular flow model and couple it to a micro-scale discrete particle model (DPM). This project also runs in close collaboration with an industrial partner, Tata Steel.

PROGRESS

A highly effective averaging technique called coarse graining was extended to bidisperse mixtures varying in both size and density. Given the particle information such as positions, velocities and forces acting on them, one can extract the macroscopic field variables like density, velocity and stresses. The fields are no approximations as they are constructed to locally satisfy the mass and momentum balance equations. By this micro-macro mapping, one can use DPMs to develop and calibrate novel, improved continuum models.

DISSERTATIONS

-

SCIENTIFIC PUBLICATIONS

1. Tunuguntla D. R.; Bokhove, O. and Thornton A. R. A mixture theory for size and density segregation in shallow granular free-surface flows, *Journal of Fluid Mechanics*, 749, 99-112.

PROJECT LEADERS

JJW van der Vegt, S Luding
AR Thornton

RESEARCH THEME

Mathematical and computational
methods for fluid flow analysis

PARTICIPANTS

DR Tunuguntla

COOPERATIONS

T Weinhart, TATA Steel

FUNDED

STW
University -
FOM -
STW 100 %
NWO Other -
Industry -
TNO -
GTI -
EU -
Scholarships -

START OF THE PROJECT

2011

INFORMATION

DR Tunuguntla
053 489 3373
D.R.Tunuguntla@utwente.nl

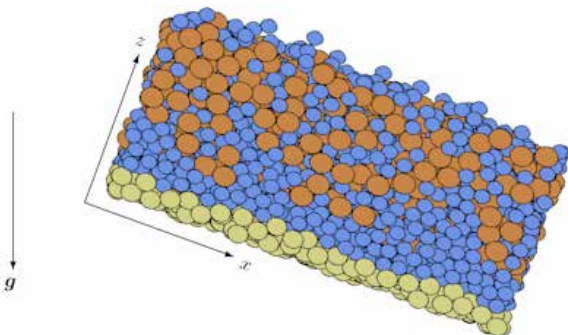

Bi-disperse mixture flows flowing over a rough inclined channel.



Prof.dr. SJMH Hulscher

The work of the “Water Engineering and Management (WEM) group was originally mainly devoted to the modelling of sand waves on the seabed. First it was shown, that the seabed patterns in the North Sea can be explained as free instabilities of the seabed. Subsequently, the modelling of sand waves was extended and refined. The group has worked on a scientific and practical tool for fully nonlinear modelling of sand waves. Over the last five years, the offshore morphodynamic work has broadened to rivers, coasts and blue-ice. Alternate bars in a flume were compared with (Ginzburg-)Landau-type models. The group was the first to explore data assimilation for morphodynamic predictions. Further work concentrated on using data assimilation to combine field data with sand wave amplitude models for maintenance dredging management of navigation channels and sand wave-related pipeline problems. Also, North Sea data were analysed and a new bed mode, called long bedwaves, was discovered. The origin of nearshore bars was addressed. A method was developed for modelling human interferences in a morphodynamic setting. This has opened perspectives for a new approach towards modelling large-scale sand mining in shallow seas. A project for developing tools for evaluation of human interference in the North Sea for optimal management of the seabed started recently and sediment transport concerning near-shore sand pits is being investigated. Since 2000 the group has studied the use of morphodynamical models in a societal context. Recently, a method for decision making based on quantitative information including uncertainties was developed in the multidisciplinary project Flyland, which opens the field of designing an assessment framework for appropriate modelling.

SMARTSEA - SAFE NAVIGATION BY OPTIMIZING SEA BED MONITORING AND WATERWAY MAINTENANCE USING FUNDAMENTAL KNOWLEDGE OF SEA BED DYNAMICS

PROJECT AIM

We aim to devise an optimized policy of sea bed monitoring and waterway maintenance in shallow seas, based on knowledge of sea bed dynamics, in order to warrant both nautical safety and port access. To this end, we define three subprojects: P1 on the influence of storm events and wind waves on sand wave dynamics; P2 on the feedback among waterways, waterway maintenance (e.g., dredging) and the surrounding seabed environment; and P3 on how to translate/combine knowledge of marine systems into a national survey and maintenance policy for the Netherlands Continental Shelf and waterways?.

PROGRESS

Subproject 1 (G.H.P. Campmans) started in March 2014. The research proposal has been written and passed the discipline board qualifier. A linear idealized sand-wave model has been created, and the first storm-related processes have been implemented. Additional storm-related processes are now being added.

Subproject 2 (J.M. Damen) started in Oktober 2014. The current focus is on writing research proposal for the qualifier to be defended before the discipline board in May 2015. Furthermore, a literature study is being composed of knowledge of sand wave development.

DISSERTATIONS

-

SCIENTIFIC PUBLICATIONS

1. Roos, P.C., A.A. Verhagen, T.A.G.P. van Dijk, S.J.M.H. Hulscher, R.F. Hanssen, L.L. Dorst, N.A. Kinneging & R. Bijker (2014). 'SMARTSEA: Safe navigation by optimizing sea bed monitoring and waterway maintenance using fundamental knowledge of sea bed dynamics.' Poster presentation at NCK-days 2014, 26-29 March 2014, UNESCO-IHE, Delft, Netherlands.

PROJECTLEADERS

PC Roos

RESEARCHTHEME

Mathematical and computational methods for fluid flow analysis

PARTICIPANTS

GHP Campmans, JM Damen, R Toodesh, TAGP van Dijk, PC Roos, AA Verhagen, SJMH Hulscher, RF Hanssen, LL Dorst, T Ligteringen, NA Kinneging

COOPERATIONS

Rijkswaterstaat, Netherlands Hydrographic Service, Advanced Consultancy Romke Bijker, Arcadis Nederland, MOW Vlaamse Hydrografie, Deltares, Delft University of Technology

FUNDED

STW (TKI Maritime Call)
Co-funders: Rijkswaterstaat, Netherlands Hydrographic Service, Deltares, Advanced Consultancy Romke Bijker (ACRB) University -
FOM -
STW 63 %
NWO Other -
Industry 33 %
TNO -
GTI 4 %
EU -
Scholarships -

START OF THE PROJECT

2014

INFORMATION

PC Roos
053 489 5608
p.c.roos@utwente.nl

PROJECT LEADERS

SJMH Hulscher

RESEARCH THEME

Complex dynamics of fluids

PARTICIPANTS

W Chen, PC Roos, HM Schuttelaars,
SJMH Hulscher

COOPERATIONS

Closely linked to Future Ems project
and TU Delft

FUNDED

University of Twente
CSC (China Scholarship Council)
scholarship
Future Ems project
University -
FOM -
STW -
NWO Other -
Industry -
TNO -
GTI -
EU -
Scholarships 100 %

START OF THE PROJECT

2011

INFORMATION

WL Chen
053 489 2959
w.chen-3@utwente.nl
www.wem.ctw.utwente.nl

PROJECT AIM

The main objective of this project is to understand a scientific problem: how does 'basin-scale' sand extraction affect the set-up at the coast, both in the short term (immediately after extraction) and in the long term (through changes in morphology)? And solve a design problem: to warrant coastal safety, is it possible to shape the sand extractions required for nourishments and land reclamations such that potentially adverse effects of these interventions are minimized? Develop a three-dimensional hydro- and morphodynamic model that allowing for a quick and systematic analysis of residual circulation and set-up at the coast, accounting for the basin's morphodynamic evolution, the balance is between wind stress, atmospheric pressure gradient, density gradient, and river runoff. This model should (1) provide insight into the physical mechanisms, and (2) serve as a tool to analyze the impacts of various spatial extraction scenarios.

PROGRESS

In the year of 2014-2015, we have developed a 3D semi-analytical using collocation technique to study the resonance properties of a closed basin subject to periodic wind forcing. The result has been presented on NCK Days 2014, and written into a journal paper which is accepted by Ocean Dynamics. We extend this study to varying topography, to study the influence of topography on resonance properties, the result was presented on PECS 2014. We also extend the 3D semi-analytical surge model to a basin with open boundary. Next step is to investigate the influence of topography on resonance properties and storm surge of a large scale semi-enclosed basin, which will contribute to our understand on the effect of large scale sea bed change induced by sand extraction.

DISSERTATIONS

-

SCIENTIFIC PUBLICATIONS

- Chen, W., Roos, P.C., Schuttelaars, H.M. & Hulscher, S.J.M.H. (2014). Resonance properties of a closed rotating rectangular basin subject to periodic wind forcing. In M.S. Ab Razak, L. Sembiring & M. van der Wegen (Eds.), Book of abstracts NCK-days 2014, 27-28 March 2014, Delft (pp. 23-23). Delft: UNESCO-IHE.
- Chen, W., Roos, P.C., Schuttelaars, H.M. & Hulscher, S.J.M.H. (2014). Storm surge response in large scale basins: influence of topography. Book of abstract Physics of Estuaries and Coastal Seas (PECS) conference, Porto de Galinhas, Pernambuco, Brazil, 19-24 October 2014.
- Chen, W., Roos, P.C., Schuttelaars, H.M. & Hulscher, S.J.M.H. (2014). Resonance properties of a closed rotating rectangular basin subject to space- and time-dependent wind forcing.

AEOLIAN AND HYDRODYNAMIC SAND EXCHANGE ACROSS BEACHES

PROJECT AIM

The objective of this study is to understand and model the exchange of sand, between the nearshore zone and the dunes on a time scale of years to decades. As the accretionary part of the exchange is the least understood, an important part of this study will be to determine to what extent different characteristics of the intertidal beach influence the rates of aeolian sand transport. This project focuses on providing a better understanding of the extent to which the intertidal zone properly works as a sediment source for onshore aeolian transport. This zone is expected to be a crucial element in the relationship between dune development and the dynamics of nearshore bars in the long-term.

PROGRESS

On May 2014 I presented my Proposal Research to obtain the PhD Candidature to the Discipline Board of the Civil Engineering Faculty and it was approved on June 2014. During September and October of 2014 fieldwork was developed at the Zandmotor (Kijkduin) with aim to collect data on rates of aeolian sand transport using laser particle counting sensors and exploring the effects of sensor positioning on the recording of aeolian transport, including possible sensor related influences. Also during 2014 two conference abstracts have been submitted and accepted.

DISSERTATIONS

-

SCIENTIFIC PUBLICATIONS

1. Duarte Campos, L.A. and Wijnberg, K.M. and Reim, E. and Hulscher, S.J.M.H. (2014) "Estimating aeolian sand supply from the intertidal beach using video imagery". Book of Abstracts NCK days 2014, 26-28 March 2014. Delft (pp. 29 - 29). Unesco-IHE.
2. Duarte Campos, L.A. and Wijnberg, K.M. and Reim, E. and Hulscher, S.J.M.H. (2014) "Estimacion del transporte eólico de arena desde la zona intermareal usando imágenes de video". Book of Abstracts Latin-American Conference of Hydraulics, 25-29 August 2014. Santiago de Chile (pp. 1 - 2). IAHR-CEDEX.

PROJECT LEADERS

SJMH Hulscher,
CM Dohmen-Janssen

RESEARCH THEME

Complex dynamics of fluids

PARTICIPANTS

L Duarte Campos, KM Wijnberg,
SJMH Hulscher

COOPERATIONS

Closely linked to: NatureCoast
Project, CoCoChannel Project.

FUNDED

CONICYT (National Commission
for Scientific and Technological
Research of Chile)

| | |
|--------------|-------|
| University | - |
| FOM | - |
| STW | - |
| NWO Other | - |
| Industry | - |
| TNO | - |
| GTI | - |
| EU | - |
| Scholarships | 100 % |

START OF THE PROJECT

2013

INFORMATION

L Duarte Campos
053 489 1094

l.a.duarte campos@utwente.nl
[www.utwente.nl/ctw/wem/organisatie/
medewerkers/duarte%20campos/](http://www.utwente.nl/ctw/wem/organisatie/medewerkers/duarte%20campos/)
Leonardo_Duarte/

LINKING BUILDING-WITH-NATURE TYPE INTERVENTIONS IN CHANNEL-SHOAL SYSTEMS TO SUB-AERIAL IMPACTS ON THE BEACH-DUNE SYSTEM

PROJECT LEADERS

KM Wijnberg

RESEARCH THEME

Complex dynamics of fluids

PARTICIPANTS

FG Silva, SJMH Hulscher, AV de Groot, JPM Mulder

COOPERATIONS

IMARES, Deltares, UNESCO-IHE, Delft University of Technology, Arcadis, Rijkswaterstaat Waterdienst, Arens Bureau voor strand en duinonderzoek, Hoogheemraadschap Hollands Noorderkwartier

FUNDED

| | |
|--|--------|
| NWO, Hoogheemraadschap Hollands Noorderkwartier University | - |
| FOM | - |
| STW | - |
| NWO Other | 92,3 % |
| Industry | - |
| TNO | - |
| GTI | - |
| EU | 7,7 % |
| Scholarships | - |

START OF THE PROJECT

2014

INFORMATION

FG Silva
053 489 1013
f.gallifornisilva@utwente.nl
www.utwente.nl/ctw/wem/organisatie/medewerkers/wijnberg/kathelijne/index.html

PROJECT AIM

The aim of this project is to link Building-with-nature interventions in channel-shoal systems in tidal inlets to impacts in the adjacent beach-dune system, in a convenient time-scale for stakeholders. Therefore, it is necessary to understand which scenarios of beach-dune system response can be expected to occur under various shoreline development conditions and make the insights accessible to the stakeholder community.

PROGRESS

The project started in November 2014. Hence, relevant literature has been studied in order to situate the current study within the present knowledge. Furthermore, courses were taken to improve research skills. For now, the main task has been the elaboration of the PhD proposal.

DISSERTATIONS

-

SCIENTIFIC PUBLICATIONS

-

RIVER BED FORM EVOLUTION MODELING FOR FLOOD MANAGEMENT

PROJECT AIM

Subproject 1: Dune evolution and transition to plane beds (van Duin)

Subproject 2: The influence of suspended sediment transport on dune evolution (Naqshband)

Subproject 3: Application of bed form roughness in operational flood modelling (Warmink).

PROGRESS

In the past period the main focus for subproject 1 was to 1) test different bed load transport formulations for their potential to predict upper-stage plane bed, 2) further optimize pick-up and deposition models and underlying step length models, 3) validating the resulting dune evolution model with a dataset used by Shimizu et al. to prove that we can predict upper-stage plane bed and hysteresis effects.

For subproject 2 the main focus was to process and analyse data from the second experimental series carried out in Braunschweig (November 2012 to January 2013). The analysis of this data set showed promising results in quantifying the contribution of bed and suspended load to migrating dunes in equilibrium. Furthermore, the processes found from the experimental data is now being incorporated in the dune evolution model to better predict dune dimensions and therefore water levels.

DISSERTATIONS

1. Naqshband, Suleyman (2014, December 18). Morphodynamics of river dunes: suspended sediment transport along mobile dunes and dune development towards upper stage plane bed. University of Twente (149 pag.) (Enschede: University of Twente). Prom./coprom.: prof.dr. S.J.M.H. Hulscher & dr.ir. J.S. Ribberink.

SCIENTIFIC PUBLICATIONS

1. Van Duin, O.J.M., S.J.M.H. Hulscher, J.S. Ribberink, C.M. Dohmen-Janssen. (2014, submitted). Which bed load transport formulations allow modelling the transition from dunes to upper-stage plane beds?
2. Van Duin, O.J.M., S.J.M.H. Hulscher (2014, submitted). Modelling the transition from dunes to the upper-stage plane bed. River Flow 2014.
3. Naqshband, S., Ribberink, J.S., Hurther, D. & Hulscher, S.J.M.H. (2014). Bed load and suspended load contributions to migrating sand dunes in equilibrium. Journal of geophysical research. Earth surface, 119(5), 1043-1063. 10.1002/2013JF003043.
4. Naqshband, S., Ribberink, J.S. & Hulscher, S.J.M.H. (2014). Using both free surface effect and sediment transport mode parameters in defining the morphology of river dunes and their evolution to upper stage plane beds, doi: 10.1061/(ASCE)HY.1943-7900.0000873. Journal of hydraulic engineering, 140(6), 1-6. 10.1061/(ASCE)HY.1943-7900.0000873.
5. Naqshband, S., Ribberink, J.S., Hulscher, S.J.M.H. & Hurther, D. (2014). Sediment transport distribution along developing sand dunes. In A.J. Schleiss, G. De Cesare, M.J. Franca & M. Pfister (Eds.), River Flow 2014 (pp. 1039-1044). Londen: Taylor & Francis Group.
6. Naqshband, S., Ribberink, J.S., Hurther, D. & Hulscher, S.J.M.H. (2014). Turbulent sediment fluxes along migrating sand dunes. In D.C.M. Augustijn & J.J. Warmink (Eds.), Book of Abstracts NCR-Days 2014, Enschede, October 2-3 (pp. 53-54). Enschede: University of Twente.

PROJECT LEADERS

SJM Hulscher,
CM Dohmen-Janssen

RESEARCH THEME

Mathematical and computational methods for fluid flow analysis

PARTICIPANTS

OJM van Duin, S Naqshband,
JJ Warmink, JS Ribberink,
R Schielen, AJ Paalberg

COOPERATIONS

Deltares, HKV, Rijkswaterstaat,
Waterdienst, University of
Braunschweig

FUNDED

NWO/STW, University of Twente,
Deltares/RWS, HKV
University 45 %
FOM 50 %
STW -
NWO Other -
Industry 5 %
TNO -
GTI -
EU -
Scholarships -

START OF THE PROJECT

2010

INFORMATION

OJM van Duin
O.J.M.vanDuin@utwente.nl

S Naqshband
S.Naqshband@utwente.nl

J.J. Warmink
J.J.Warmink@utwente.nl

7. Naqshband, S., Ribberink, J.S., Hurther, D. & Hulscher, S.J.M.H. (2014). Best presentation Award: Turbulent sediment fluxes along migrating sand dunes. NCR-Days 2014, 2-3 October 2014: Enschede. Prijis / Beurs.
8. Warmink, J.J., Dohmen-Janssen, C.M., Lansink, J., Naqshband, S., Duin, O.J.M. van, Paarlberg, A.J., Termes, A.P.P. & Hulscher, S.J.M.H. (2014). Understanding river dune splitting through flume experiments and analysis of a dune evolution model. *Earth surface processes and landforms*, 39(9), 1208-1220. 10.1002/esp.3529.
9. Warmink, J.J. (2014) Dune dynamics and roughness under gradually varying flood waves, comparing flume and field observations. *Advances in Geosciences*, 39, 115-121, DOI:10.5194/adgeo-39-115-2014
10. Warmink, J.J., Dohmen-Janssen, C.M., Lansink, J., Naqshband, S., Van Duin, O.J.M., Paarlberg, A.J., Termes, A.P.P., Hulscher, S.J.M.H. (2014). Understanding river dune splitting through flume experiments and dune evolution model analysis. *Earth Surface Processes and Landforms* 39(9) 1208-1220. DOI:10.1002/esp.3529 (I.F.*: 2.5).
11. Warmink, J.J., Schielen R.M.J. (2014). Explicit computation of bed form roughness for operational flood modelling, a case study for the river Rhine. In A.J. Schleiss et al. (Eds.) *Proceedings River Flow 2014*, Lausanne, Switzerland, pp 375-380.
12. Aguilar Lopez, J.P., Warmink, J.J., Schielen, R.M.J., Hulscher, S.J.M.H. (2014). Data-driven surrogate models for flood defence failure probability estimation, case study “Jarillon de Cali, Colombia”. In 11th International conference on hydroinformatics HIC 2014, New York City, USA, pp 1–8.
13. Augustijn, D.C.M. and Warmink, J.J. (Eds.) *Proceedings NCR-days 2014*, Enschede, October 2-3.
14. Hulscher, S.J.M.H., Schielen, R.M.J., Augustijn, D.C.M., Warmink, J.J., Van der Voort, M.C., Middelkoop, H., Kleinhans, M.G., Leuven, R.S.E.W., Lenders, H.J.R., Smits, A.J.M., Fliervoet, J.M., Uijttewaai, W.S.J., Blom, A., Wallinga, J., Hoitink, A.J.F., Buijsse, A.D., Geerling, G.W., Makaske, B. (2014). RiverCare, towards self-sustaining multifunctional rivers. In D.C.M. Augustijn & J.J. Warmink (Eds.), *Proceedings NCR-days 2014*, Enschede, October 2-3, pp 13-14.
15. Seuren, J.M., Duin, O.J.M., Warmink, J.J., Knaapen, M.A.F., Hulscher, S.J.M.H. (2014). River dune predictions, comparison between a parameterized dune model and a cellular automation dune model. In D.C.M. Augustijn & J.J. Warmink (Eds.), *Proceedings NCR-days 2014*, Enschede, October 2-3, pp 69-70.
16. Ten Hagen, E.D.M., Huthoff, F. Warmink, J.J. (2014) Hydrodynamic modelling with unstructured grid using D-Flow-FM, case study Afferden-Deest. In D.C.M. Augustijn & J.J. Warmink (Eds.), *Proceedings NCR-days 2014*, Enschede, October 2-3, pp 39-40.
17. Warmink, J.J. (2014). Explicit computation of dynamic bed form roughness for operational flood modelling using a time-lag approach. In D.C.M. Augustijn & J.J. Warmink (Eds.), *Proceedings NCR-days 2014*, Enschede, October 2-3, pp 77-78.
18. Warmink, J.J., Schielen, R.M.J. (2014). Modelling dynamic bed form roughness for operational flood forecasting. *Proc. 3rd IAHR Europe Congress*, Porto, Portugal, pp 1-10.
19. Aguilar Lopez, J.P., Warmink, J.J., Schielen, R.M.J., Hulscher, S.J.M.H. (2014). Flood defence design parameters correlation influence on failure probability case study of backward erosion piping. *Proc. 3rd IAHR Europe Congress*, Porto, Portugal, pp 1-12.

THE EFFECT OF MEGA-NOURISHMENT PROJECTS ON SAND SUPPLY TO THE DUNES

PROJECT AIM

Recently, a mega-nourishment (21 Mm³ of sand) has been built at the Dutch coast. This is an innovative way of nourishing which is expected to protect the coast for approximately 20 years. The goal of this study is to describe and explain the impact of mega-nourishments on spatial and temporal variation in aeolian sediment supply (i.e. wind-driven) towards the upper beach and foredunes on a medium long time scale (e.g. 20 years). Currently, it is still unresolved how to estimate longer term and larger scale dune behaviour, although this knowledge is essential for assessing coastal dune safety. The research is part of an "STW Perspectief Programma" NatureCoast.

PROGRESS

Preparation of field experiments, including design of field equipment and selection and testing of instruments. Field data collection, including repeated topographic surveys of the dune area and first exploratory field experiment.

DISSERTATIONS

-

SCIENTIFIC PUBLICATIONS

1. Weerd, A.J. van der, Wijnberg, K.M., Hulscher, S.J.M.H. (2014). An innovative way to track aeolian sediment transport patterns by using Argus video system. In M.S.A. Razak, L. Sembiring & M. van der Wegen (Eds.), NCK-days Preparedness, March 2014 (p.76). Delft: UNESCO-IHE.
2. Wijnberg, K.M., Van der Weerd, A.J., Hulscher, S.J.M.H. (2014). Tracking Aeolian transport patterns across a mega-nourishment using video-imagery. Geophysical Research Abstracts, Vol. 16, EGU2014-9187, EGU General Assembly 2014, Vienna, Austria, 1 p.

PROJECTLEADERS

KM Wijnberg

RESEARCHTHEME

Complex dynamics of fluids

PARTICIPANTS

AJ van der Weerd, SJMH Hulscher

COOPERATIONS

Wageningen University, Delft University of Technology, Utrecht University, VU University of Amsterdam, NIOZ, Alterra, United States Geological Service (USGS), Deltares

FUNDED

| | |
|--------------|-------|
| STW | |
| University | - |
| FOM | - |
| STW | 100 % |
| NWO Other | - |
| Industry | - |
| TNO | - |
| GTI | - |
| EU | - |
| Scholarships | - |

START OF THE PROJECT

2013

INFORMATION

L van der Weerd
053 489 8038
a.j.vanderweerd@utwente.nl
www.utwente.nl/ctw/wem/organisatie/medewerkers/weerd/lianne/

PROJECT LEADERS

SJMH Hulscher, JJ Warmink,
RMJ Schielen

RESEARCH THEME

Mathematical and computational
methods for fluid flow analysis

PARTICIPANTS

JP Aguilar López, JJ Warmink, RMJ
Schielen, Dohmen-Janssen, SJMH
Hulscher, M Kok

COOPERATIONS

Deltares, HKV, Rijkswaterstaat,
Waterdienst, Arcadis

FUNDED

| | |
|-----------------|-------|
| STW-perspectief | |
| University | - |
| FOM | - |
| STW | 100 % |
| NWO Other | - |
| Industry | - |
| TNO | - |
| GTI | - |
| EU | - |
| Scholarships | - |

START OF THE PROJECT

2012

INFORMATION

J Pablo Aguilar
053 489 40 38
j.p.aguilarlopez@utwente.nl
www.utwente.nl/ctw/wem/organisatie/
medewerkers/aguilarlopez.doc/

PROJECT AIM

Flood risk safety philosophy is changing more and more in the direction of a system probability of failure approach, which should replace the current overload per dike section approach. The project aims to:

1. Estimate the main failure mechanisms considering their possible correlations.
2. Derive set of limit state equations based in other common variables.
3. Emulate the failure mechanisms from model.
4. Implement the methodology in the current safety assessment.

PROGRESS

For the case of backward erosion also known as piping, correlation between the sand grain size and the permeability might influence the outcome by several orders of magnitude. This is important for reducing the uncertainty for the dimensioning of this kind of structures. The actual limit state function developed by Sellmeijer is not able to capture the influence of embed structures in the foundation of the flood defence. Therefore a FEM emulation method is developed and test at the moment for design of multi-functional flood defences.

DISSERTATIONS

-

SCIENTIFIC PUBLICATIONS

1. Aguilar Lopez, J.P., Warmink, J.J., Schielen, R.M.J. & Hulscher, S.J.M.H. (2014). Flood defence design parameters correlation influence on failure probability - case study of backward erosion piping. In 3rd IAHR Europe congress, Book of proceedings, 14-16 April 2014, Porto-Portugal (pp. 1-12). Porto: IAHR.
2. Aguilar Lopez, J.P., Andel, S.J. van, Werner, M. & Solomatine, D.P. (2014). Hydrodynamic and water quality surrogate modelling for reservoir operation. In 11th International conference on hydroinformatics HIC 2014, 17-21 August 2014, New York City, USA (pp. 1-8). New York City.
3. Aguilar Lopez, J.P., Warmink, J.J., Schielen, R.M.J. & Hulscher, S.J.M.H. (2014). Data-driven surrogate models for flood defence failure probability estimation: case study "Jarillon de Cali, Colombia". In 11th International conference on hydroinformatics HIC 2014, 17-21 August 2014, New York City, USA (pp. 1-8). New York City.
4. Aguilar Lopez, J.P., Warmink, J.J., Schielen, R.M.J. & Hulscher, S.J.M.H. (2014). Correlation impact in piping erosion for safety assessment of multi-functional flood defences. In D.C.M. Augustijn & J.J. Warmink (Eds.), Book of Abstracts NCR-Days 2014, Enschede, October 2-3 (pp. 45-46). Enschede: University of Twente.

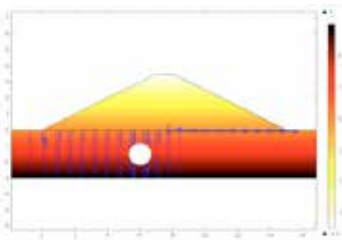

SAND TRANSPORT UNDER IRREGULAR AND BREAKING WAVE CONDITIONS

PROJECT AIM

The research has two main aims: (1) to improve understanding of the near-bed hydrodynamics and sand transport processes occurring under real-scale irregular non-breaking and regular breaking wave conditions and (2) to develop a new practical model for predicting sand transport under waves, accounting for wave irregularity and wave breaking in a way that is well founded on experimental data and understanding of the fundamental processes. The research is based on a combination of fixed and mobile bed laboratory experiments (incl. PhD-project J. van der Zanden) and process-based numerical modeling (incl. post-doc A. Fernández Mora).

PROGRESS

Measurements on flow, turbulence, sediment concentrations and transport under irregular and breaking waves have taken place in the large scale wave flume in Barcelona. Two experimental campaigns with a mobile beach/bed (medium-grained sand) and fixed beach/bed have been finished. A numerical model developed before for flow and transport under regular non-breaking waves has been validated for transport by irregular waves and applied in a parameter study. A new postdoc (A. Fernández Mora), who will work on process-based modeling of near-shore morphodynamics, was appointed.

DISSERTATIONS

-

SCIENTIFIC PUBLICATIONS

1. Alsina, J.M., Caceres, I., van der Zanden, J., Ribberink, J.S., Baldock, T.E. (2014) 'Large scale experiments on beach evolution induced by bichromatic wave groups with varying wave group period', in: Lynett, P.J. (ed), Proc. of 34th Int. Conf. on Coastal Engineering, 8 pp.
2. Alsina, J.M., Zanden, J. van der, Ribberink, J.S., Buijsrogge, R.H., Baldock, T.E., Brocchini, M., Pena, E., Sanchez-Tembleque, F. & Caceres, I. (2014). 'Sediment transport and beach profile evolution induced by bichromatic waves with different grouping periods'. In S. McLelland & I. Caceres (Eds.), Proc. of the HYDRALAB IV Joint user meeting, Lisbon, July 2014 (pp. 1-9). Lisbon: Hydralab.
3. Ribberink, J.S., van der A, D.A., van der Zanden, J., O'Donoghue, T., Hurther, D., Caceres, I., Thorne, P.D. 'SandT-Pro: Sediment transport measurements under irregular and breaking waves', in: Lynett, P.J. (ed), Proc. of 34th Int. Conf. on Coastal Engineering, 10 pp.
4. Ribberink, J.S., A, D.A. van der, Zanden, J. van der, O'Donoghue, T., Hurther, D., Caceres, I. & Thorne, P.D. (2014). Measurements of sand transport and its underlying processes under large-scale breaking waves (SandT-Pro). In S. McLelland & I. Caceres (Eds.), Proc. of the HYDRALAB IV Joint user meeting, Lisbon, July 2014 (pp. 1-8). Lisbon: Hydralab.
5. Ribberink, J.S., O'Donoghue, T., A, D.A. van der, Zanden, J. van der, Hurther, D., Caceres, I. & Thorne, P.D. (2014). 'Measurements of sand transport processes under breaking and irregular waves'. IAHR newsletter (International Association for Hydraulic Research), 2014(3), 86-87.

PROJECT LEADERS

JS Ribberink

RESEARCH THEME

Complex dynamics of fluids

PARTICIPANTS

J van der Zanden, A Fernández Mora, JJ van der Werf

COOPERATIONS

Deltares

University of Aberdeen, UK

University of Liverpool, UK

Bangor University, UK

Universitat Politècnica de Catalunya

LEGI, Grenoble, Fr

National Oceanography Centre, UK

FUNDED

SINBAD (STW/EPSRC)

Hydralab IV-WISE (EU)

University 80 %

FOM -

STW -

NWO Other -

Industry -

TNO -

GTI -

EU 20 %

Scholarships -

START OF THE PROJECT

2012

INFORMATION

J van der Zanden

053 489 4038

j.vanderzanden@utwente.nl

www.utwente.nl/ctw/wem/

PROJECT LEADERS

SJM Hulscher

RESEARCH THEME

Mathematical and computational
methods for fluid flow analysis

PARTICIPANTS

V Vuiik, I Kreutzer, S Janssen,
BW Borsje

COOPERATIONS

Tu Delft, NIOZ Yerseke

FUNDED

| | |
|-----------------------------------|------|
| Boskalis, Van Oord, Deltares, ALW | |
| University | - |
| FOM | - |
| STW | - |
| NWO Other | 50 % |
| Industry | 50 % |
| TNO | - |
| GTI | - |
| EU | - |
| Scholarships | - |

START OF THE PROJECT

2014

INFORMATION

BW Borsje
053 489 4038
b.w.borsje@utwente.nl

PROJECT AIM

We aim to develop new methods to assess how, and how much vegetated foreshores can contribute to flood risk reduction. The project will lead to a better understanding of (uncertainties in) the functioning and stability of these ecosystems and the development of novel governance arrangements. This requires integration of knowledge from ecology, biogeomorphology, hydraulic engineering, and governance.

PROGRESS

By field observations on several sites and flume measurements we analysed fundamental ecological and physical processes for various types of wetland vegetations. The knowledge obtained is applied in one implementation case study for a location in the Netherlands where dike reinforcement is needed. This case study integrates fundamental knowledge from all the disciplines. It is used to design governance and implementation arrangements, and to demonstrate how vegetated foreshores can contribute to flood risk reduction.

DISSERTATIONS

-

SCIENTIFIC PUBLICATIONS

1. Borsje, B.W., Bouma, T.J., de Vries, M.B., Timmermans, J.S., Vuiik, V., Hermans, L.M., Hulscher, S.J.M.H., Jonkman, S.N. 2014. Vegetated foreshores as coastal protection strategy : Coping with uncertainties and implementation. Abstract for EGU 2014 Vienna.



Prof.dr.ir. RWCP Verstappen

The group Computational Mechanics and Numerical Mathematics at the University of Groningen focuses on the development of numerical solution methods for partial differential equations in general, and for (aero- and hydrodynamic) flow simulation in particular (CFD). Keywords for our algorithmic developments are symmetry-preserving discretization, Cartesian cut-cell approach, sharp-interface methods, efficient sparse-matrix solvers and large-scale continuation methods. It is our strategy to combine all algorithmic innovations from the individual research projects into one coherent CFD concept, such that all projects can profit from each other.

Application areas are direct and large-eddy simulation of turbulent flow, free-surface flow in aerospace (sloshing onboard spacecraft) and maritime engineering (hydrodynamic wave loading), oceanography (stability of the global ocean circulation), bio-medical fluid dynamics (hemodynamics) and heat transport (Rayleigh-Bénard flow). We plan to extend our research efforts towards multi-physics: fluid-structure interaction, two-phase flow, atmospheric flow and turbulent combustion. In the process of knowledge transfer, the in-house developed computer codes ComFlo and MRILU play an important role.

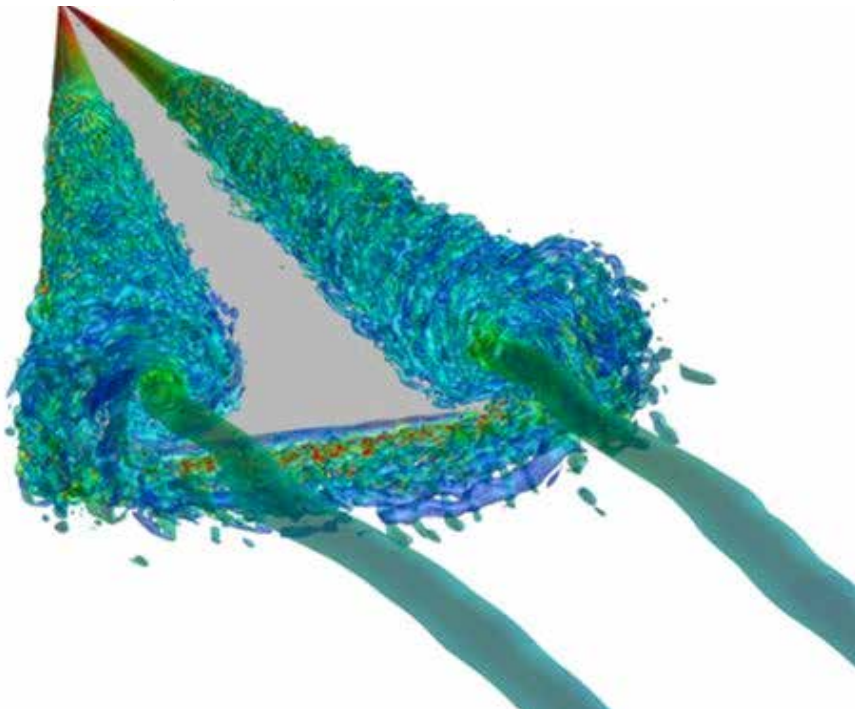
DNS of flow past a delta wing at $Re=200,000$.

PROJECT AIM

A main area of research concerns turbulent flow simulation. Turbulence modeling keeps computational effort within reasonable limits, but a price is paid in terms of accuracy. Thus research into direct numerical simulation (DNS) is envisaged. Our group concentrates on improving numerical techniques with which the price of DNS can be reduced significantly. Additionally, steps towards a mathematical-based Large-Eddy Simulation (LES) modeling are made.

PROGRESS

The aim of the project is to simulate turbulence such that the symmetry and conservation properties of the Navier-Stokes equations are preserved. In cooperation with MARIN a PhD-project was completed which aims to extend the method to unstructured grids at high Reynolds numbers. The joint work with UPC (Barcelona) has resulted into a paper on symmetry-preserving Navier-Stokes discretizations on collocated unstructured grids. In cooperation with NLR a PhD project was completed in which low-dissipation models for LES are developed. A PhD project on scale truncation models for LES is continued.

DISSERTATIONS

-

SCIENTIFIC PUBLICATIONS

1. B. Sanderse, R.W.C.P. Verstappen and B. Koren, Boundary treatment for fourth order staggered mesh discretizations of the incompressible Navier-Stokes equations, *Journal Computational Physics* 257, 1472--1505 (2014).
2. F.X. Trias, O. Lehmkuhl, A. Olivia, C.D. Perez-Sagarra and R.W.C.P. Verstappen, Symmetry-preserving discretizations of Navier-Stokes equations on collocated unstructured grids, *Journal Computational Physics* 258, 246--267 (2014).
3. W. Rozema, J.C. Kok, R.W.C.P. Verstappen and A.E.P. Veldman, A symmetry-preserving discretization and regularization model for compressible flow with application to turbulent channel flow, *Journal of Turbulence* 15, 368--410 (2014).
4. H.J. Bandringa, R.W.C.P. Verstappen, F.W. Wubs, C.M. Klaij and A. van der Ploeg, Towards large eddy simulation of complex flow in maritime applications, *Proc. ECCOMAS CFD 2014, Barcelona*.
5. W. Rozema, R.W.C.P. Verstappen, J.C. Kok and A.E.P. Veldman, Discretization and regularization models for compressible flow that preserve the skew-symmetry of the convective transport, *Proc. ECCOMAS CFD 2014, Barcelona*.
6. M.H. Silvis and R.W.C.P. Verstappen, Scale-truncation models for large-eddy simulation, *Proc. ECCOMAS CFD 2014, Barcelona*.
7. R.W.C.P. Verstappen and F.X. Trias, Advanced models for large eddy simulation and regularization of turbulent flows, *Proc. ECCOMAS CFD 2014, Barcelona*.
8. W. Rozema, J.C. Kok, R.W.C.P. Verstappen and A.E.P. Veldman, DNS and LES of the compressible flow over a delta wing with the symmetry-preserving discretization, *Proc. ASME 4th joint US-European Fluids Engineering Division Summer Meeting, Chicago*.
9. R.W.C.P. Verstappen, W. Rozema and H.J. Bae, Numerical scale separation in large eddy simulation, *Proc. Summer Program 2014, Center for Turbulence Research, Stanford*.

PROJECT LEADERS

RWCP Verstappen

RESEARCH THEME

Mathematical and computational methods for fluid flow analysis

PARTICIPANTS

HJ Bandringa, AJA Kort, JA Helder, W Rozema, MH Silvis, FW Wubs, AEP Veldman, FX Trias (UPC), A Oliva (UPC), HJ Bae (CTR), P Moin (CTR)

COOPERATIONS

NLR, MARIN, TUD, UT, Polytechnical University of Catalunya (UPC), Stanford University (CTR)

FUNDED

| | |
|-----------------------------------|------|
| Maritiem Innovatieprogramma (EZ), | |
| NWO, Ubbo Emmius Fonds (RuG) | |
| University | 30 % |
| FOM | - |
| STW | - |
| NWO Other | 40 % |
| Industry | 10 % |
| TNO | - |
| GTI | - |
| EU | 10 % |
| Scholarships | 10 % |

START OF THE PROJECT

1998

INFORMATION

RWCP Verstappen

050 363 3958

R.W.C.P.Verstappen@rug.nl

www.rug.nl/staff/r.w.c.p.verstappen

PARALLEL BLOCK MULTILEVEL INCOMPLETE LU FACTORIZATION PRECONDITIONERS FOR THE NAVIER-STOKES EQUATIONS

PROJECT LEADERS

B Carpentieri

RESEARCH THEME

Mathematical and computational methods for fluid flow analysis

PARTICIPANTS

B Carpentieri, J Liao

COOPERATIONS

Prof. Aldo Bonfiglioli, Scuola di Ingegneria, University of Basilicata, Potenza, Italy, Prof. Masha Sosonkina Department of Modeling, Simulation & Visualization Engineering - Old Dominion University, Norfolk, US 23529

FUNDED

| | |
|--------------|-------|
| RUG | |
| University | 100 % |
| FOM | - |
| STW | - |
| NWO Other | - |
| Industry | - |
| TNO | - |
| GTI | - |
| EU | - |
| Scholarships | - |

START OF THE PROJECT

2011

INFORMATION

B Carpentieri
050 363 8991
b.carpentieri@rug.nl
www.rug.nl/staff/b.carpentieri/

PROJECT AIM

The solution of large block structured linear systems arising from an implicit formulation of the Reynolds Averaged Navier-Stokes equations, using Newton-Krylov methods, requires ad-hoc preconditioners for inverting the large nonsymmetric linear system at each step of the Newton's algorithm. In this project we develop a new MPI-based variable block multilevel algebraic recursive iterative solver that detects automatically exact or approximate dense structures in the coefficient matrix and exploits them to maximize computational efficiency. The performance of the new method are assessed on a suite of two- and three-dimensional realistic test cases.

PROGRESS

A fully parallel MPI-based implementation of a new variable block multilevel Incomplete LU factorization preconditioner has been developed for solving nonsymmetric linear systems. Three new parallel block solvers are produced, based on the block Jacobi, the restricted additive Schwarz method and the Schur complement preconditioners. The performance of the new preconditioner are assessed for solving turbulent Navier-Stokes equations on a suite of two- and three-dimensional test cases, among which the calculation of the flow past the DPW3-W1 wing configuration of the third AIAA Drag Prediction Workshop. These analyses are carried out with coarse to medium-sized grids featuring up to 2.5 million nodes at Reynolds number equal to $5 \cdot 10^6$. The results show that the solver may be noticeably more robust than other state-of-the-art solvers for comparable memory usage.

DISSERTATIONS

-

SCIENTIFIC PUBLICATIONS

1. B. Carpentieri, J. Liao, and M. Sosonkina. VBARMS : A variable block algebraic recursive multilevel solver for sparse linear systems. *Journal of Computational and Applied Mathematics*, 259(A):164–173, 2014. doi : 10.1016/j.cam.2013.04.036.
2. D.-L. Sun, Y.-F. Jing, T.-Z. Huang, and B. Carpentieri. A quasi-minimal residual variant of the BiCORSTAB method for nonsymmetric linear systems. *Computers & Mathematics with Applications*, 67(10) :1743–1755, 2014. doi : 10.1016/j.camwa.2014.04.014.
3. B. Carpentieri, J. Liao, and M. Sosonkina. Parallel Processing and Applied Mathematics, volume 8385 of *Lecture Notes in Computer Science*, chapter Variable block multilevel iterative solution of general sparse linear systems, pages 520–530. In R. Wyrzykowski, J. Dongarra, K. Karczewski, and Wasniewski. Springer-Verlag., 2014. ISBN 978-953-51 -0267-0. doi : N.A.
4. B. Carpentieri, J. Liao, and M. Sosonkina. Parallel Computing: Accelerating Computational Science and Engineering (CSE), volume 25 of *Advances in Parallel Computing*, chapter Variable block algebraic recursive multilevel solver (VBARMS) for sparse linear systems, pages 163 – 172. M.
5. Bader, A. Bode, H.-J. Bungartz, M. Gerndt, G.R. Joubert, F. Peters (eds.), IOS Press, 2014. ISBN 978-1-61499-380-3. doi : 10.3233/978-1-61499-381-0-163.

6. B. Carpentieri, J. Liao, M. Sosonkina, and A. Bonfiglioli. Parallel performance enhancements of pVBARMS, a package for parallel variable block algebraic multilevel solvers, with applications to turbulent flow simulations. In Proceedings of the 8th International Workshop on Parallel Matrix Algorithms and Applications PMAA14, Università della Svizzera italiana, Lugano, Switzerland, 2014.
7. Y. Bu and B. Carpentieri. A recursive multilevel approximate inverse-based preconditioner for solving general linear systems. In Proceedings of the Conference in Numerical Analysis 2014. NumAn 2014, Chania, Greece, 2014.

PROJECT LEADERS

FW Wubs

RESEARCH THEME

Mathematical and computational methods for fluid flow analysis

PARTICIPANTS

W Song (RuG), S Kotnala (RuG),
HA Dijkstra (IMAU), J Thies (DLR), S
Baars (RuG)

COOPERATIONS

IMAU (UU), DLR, TU Braunschweig,
University Erlangen

FUNDED

| | |
|----------------------|------|
| NWO, University, DLR | |
| University | 25 % |
| FOM | - |
| STW | - |
| NWO Other | 50 % |
| Industry | 25 % |
| TNO | - |
| GTI | - |
| EU | - |
| Scholarships | - |

START OF THE PROJECT

1994

INFORMATION

FW Wubs
050 363 3994
f.w.wubs@rug.nl
www.math.rug.nl/~wubs

PROJECT AIM

The aim of this project is provide fast and robust solvers for the study of dynamics and structures of incompressible fluids. Such solvers are necessary for among others (i) the coupled linear system arising from steady or implicit computations of fluid flow, (ii) the computation of eigenvalues to study the stability of a flow and (iii) the solution of a stochastic PDE to study the influence of noise on the stability of flows. The focus is on geophysical flows and flows in simple geometries.

PROGRESS

With the first version of our most recent solver HYMLS we performed bifurcation analysis on the 3D lid-driven cavity problem and on the 3D Rayleigh-Bénard problem.

With DLR several variations of HYMLS have been studied to speed it up on hybrid parallel computers.

In our cooperation with IMAU we implemented the Dynamical Orthogonal field method for stochastic PDEs.

DISSERTATIONS

-

SCIENTIFIC PUBLICATIONS

1. Dijkstra, H. A. , Wubs, F. W. , Cliffe, A. K., Doedel, E., Dragomirescu, I. F., Eckhardt, B., Alexander Yu. Gelfgat, Andrew L. Hazel, Valerio Lucarini, Andy G. Salinger, Erik T. Phipps, Juan Sanchez-Umbria, Henk Schuttelaars, Laurette S. Tuckerman, Thiele, U. (2014). Numerical Bifurcation Methods and their Application to Fluid Dynamics: Analysis beyond Simulation . *Communications in Computational Physics* , 15 (1), 1-45.
2. Song, W. , Wubs, F. W. , & Thies, J. (2014). A highly parallel code for strongly coupled fluid transport equations . *Proceedings of the 11th world congress on computational mechanics (WCCM XI)* , 199-210.

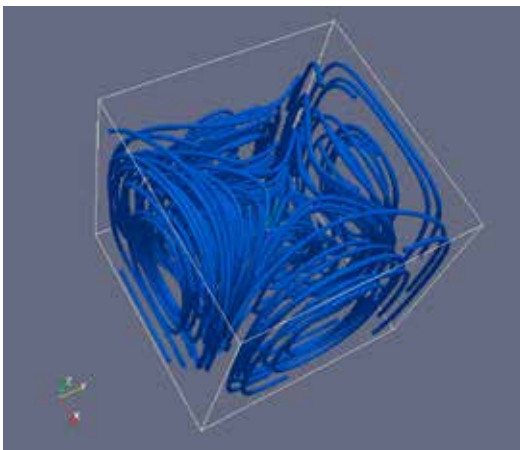

A stable Rayleigh-Benard flow

PROJECT AIM

A fast-growing application area of our ComFLOW simulation method is maritime technology. In close cooperation with MARIN, Deltares and the offshore industry, focus is on the numerical prediction of hydrodynamic wave loading (green water, slamming) and sloshing in ship tanks. Especially extreme, highly-nonlinear waves are being studied. Also, the interaction with moving (floating, deforming) objects is subject of research.

PROGRESS

The 4-year ComFLOW-3 phase of our project on hydrodynamic wave loading by extreme waves was finalized. Physical emphasis was on modelling viscous effects during wave impact. Hereto, an invariants-based QR turbulence model has been implemented, combined with a regularization model. Numerical efficiency is improved with local grid refinement. Irregular geometries are described with an immersed-boundary cut-cell method. The TUD-part of the project focused on improved wave propagation and absorbing boundary conditions. All developments have been merged and validated with MARIN experiments. A new version of the ComFLOW code has been released, with user workshops in San Francisco (USA) and Busan (Korea). A follow-up project phase, ComMotion, has been started, focusing on interactively moving (floating, deforming) objects.

DISSERTATIONS

-

SCIENTIFIC PUBLICATIONS

1. AEP Veldman, R Luppés, HJL van der Heiden, P van der Plas, B Duz and RHM Huijsmans. Turbulence modeling, local grid refinement and absorbing boundary conditions for free-surface flow simulations in offshore applications. Proc. 33rd Conf Ocean, Offshore and Arctic Eng OMAE2014, San Francisco, 8-13 June 2014, paper OMAE2014-24427 (11 pages).

PROJECT LEADERS

AEP Veldman

RESEARCH THEME

Mathematical and computational methods for fluid flow analysis

PARTICIPANTS

HJL van der Heiden, P van der Plas, H Seubers, R Luppés, AEP Veldman, B Duz (TUD), X Chang (TUD), M Hosseini (TUD), RHM Huijsmans (TUD), T Bunnik (MARIN), J Helder (MARIN), PR Wellens (Deltares), MJA Borsboom (Deltares)

COOPERATIONS

TU Delft, MARIN, Deltares, FORCE Technology (Norway)

FUNDED

| | |
|--------------|-------|
| STW | - |
| University | - |
| FOM | - |
| STW | 100 % |
| NWO Other | - |
| Industry | - |
| TNO | - |
| GTI | - |
| EU | - |
| Scholarships | - |

START OF THE PROJECT

1999

INFORMATION

AEP Veldman
050 363 3988

a.e.p.veldman@rug.nl

www.math.rug.nl/~veldman/comflow/comflow.html

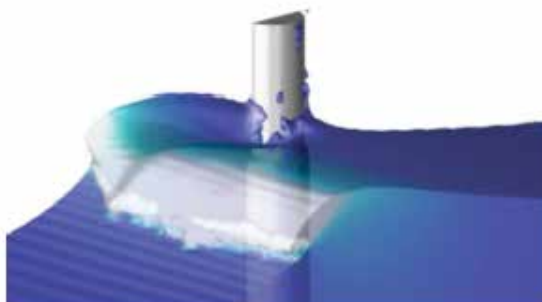

Snapshot from a numerical simulation of a wave breaking around a wind turbine tower.



Prof.dr.ir. J.L. van Leeuwen

The mission of the Experimental Zoology Group is to unravel the relationships between form and function in zoological systems in a developmental and evolutionary context and to provide bioinspired solutions for technological and health problems. The current main research area of the Experimental Zoology Group is the biomechanics of motion systems in vertebrates and insects, with three research lines that profit from one another: (1) Biomechanics of animal flight, including the biofluid dynamics of avian and insect flight and in-flight host detection of malaria mosquitoes. (2) Biomechanics of fish swimming, including swimming and developmental mechanics in larval fish, fin propulsion, visuo-motor-system development and effects of a livebearing reproductive strategy on swimming performance. This research line also includes developmental mechanics of bones and muscles linking bone remodelling to molecular regulation. (3) Bioinspired design solutions for human health, including development of steerable needles (inspired by the mechanics of the ovipositor in parasitic wasps), and construction of gentle grippers for delicate human tissues (inspired by wet adhesion of toe-pads in tree frogs). The Experimental Zoology Group participates also within the graduate school Wageningen Institute of Animal Sciences (WIAS).

FLUID-MUSCLE INTERACTION OF FREE-SWIMMING ZEBRAFISH LARVAE

PROJECT AIM

Zebrafish larvae start swimming within two days post fertilization (2 dpf), and develop rapidly over the next few days. We study how these developmental changes affect locomotory performance. To achieve this, we will create a numerical model of the larvae that accounts for the mechanics of the muscular system, the external fluid mechanics, and their mutual interactions. This approach allows us to unravel how muscle activation patterns lead to swimming motions and identify causes of changes in swimming performance across development.

PROGRESS

In order to quantify the swimming motions of the larval zebrafish, we created a large database of multiple-camera high-speed video of their swimming repertoire across development, from day 2 until 12 after fertilization. We finalized development of software that tracks the fish in three-dimensions from these data, which is described in a submitted article. The resulting three-dimensional surface descriptions of the fish are being used as input for CFD-simulations, to compute flow fields and force distributions on the fish. Furthermore, we conducted a successful pilot experiment for measuring the muscle activation patterns of free swimming fish. At a later stage, these models and data will be combined into the final integrative fluid-structure interaction model of larval fish swimming. We carried out a kinematics and inverse dynamics analysis that shows how Strouhal number and body torque varies with swimming speed in larval fish.

DISSERTATIONS

-

SCIENTIFIC PUBLICATIONS

1. Voesenek C, Pieters, RPM, van Leeuwen, JL (2014) Learning how to swim: inverse dynamics analysis of larval zebrafish swimming. In: Proceedings of the 7th World Congress of Biomechanics.
2. Muller UK, Voesenek CJ, van Leeuwen JL (2014) Larval fish fwimming - What we can learn from body dynamics. In: Proceedings of the 7th World Congress of Biomechanics.

PROJECTLEADERS

JL van Leeuwen

RESEARCHTHEME

Complex dynamics of fluids

PARTICIPANTS

CJ Voesenek, MJM Lankheet,

FT Muijres

COOPERATIONS

H Liu (Chiba University, Tokyo)

UK Müller (Univ. of Fresno)

FUNDED

| | |
|--------------|-------|
| University | 100 % |
| FOM | - |
| STW | - |
| NWO Other | - |
| Industry | - |
| TNO | - |
| GTI | - |
| EU | - |
| Scholarships | - |

START OF THE PROJECT

2012

INFORMATION

JL van Leeuwen

0317 482267

johan.vanleeuwen@wur.nl

www.ezo.wur.nl

PROJECT LEADERS

JL van Leeuwen

RESEARCH THEME

Complex dynamics of fluids

PARTICIPANTS

S Henrion

COOPERATIONS

UK Müller (Univ. of Fresno), R Mokso (PSI), TGA Vercruyssen (TUD), FTM van der Helm (TUD) CJM Verhoeven (TUD)

FUNDED

| | |
|--------------|------|
| University | 75 % |
| FOM | - |
| STW | - |
| NWO Other | - |
| Industry | 25 % |
| TNO | - |
| GTI | - |
| EU | - |
| Scholarships | - |

START OF THE PROJECT

2010

INFORMATION

JL van Leeuwen
0317 482 267
johan.vanleeuwen@wur.nl
www.ezo.wur.nl/UK

PROJECT AIM

Seahorses and cuttlefish live in closely vegetated environments where a good manoeuvring strategy is key to survival. The research focusses on manoeuvrability in seahorses and cuttlefish and aims at deriving biomechanic locomotion principles. The fundamental knowledge on how these animals execute precise manoeuvring is being implemented in bio-inspired underwater robotics and more recently swarm robotics.

PROGRESS

We developed and finalized a refraction corrected ray tracing algorithm which enables researchers to calibrate multi camera setups for aquatic locomotion research, which is currently under review. Ongoing work is the manuscript preparation for the automated 3D hull reconstruction and deformable fin kinematics of a forward swimming seahorse and the 3D musculoskeletal architecture of the dorsal fin of a seahorse acquired with fast synchrotron X-ray computed tomography. We are also working on multiple manuscripts on the performance of a bio-inspired underwater robot together with colleagues of the Delft University of Technology. A start has been made to work on a first underwater robotic swarm in cooperation with Delft Robotics Institute.

DISSERTATIONS

-

SCIENTIFIC PUBLICATIONS

1. Henrion S, Pieters RPM, Spoor CW, Voesenek CJ, & van Leeuwen JL (2014) Maneuverability is a seahorse's middle name (2014) In: Proceedings of the 7th World Congress of Biomechanics, Boston.
2. Henrion S, Gussekloo SWS, Jaklofsky M, Schipper H, Pieters RPM, van Leeuwen JL & Mokso R (2014) Fast synchrotron X-ray CT reveals sub-micron musculoskeletal dorsal fin architecture in seahorses. In Proceedings of Benelux Zoology 2014, Liege.
3. Henrion S, Pieters RPM, Spoor CW, Voesenek CJ & van Leeuwen JL (2014) Semi-automatic 3D reconstruction of body and fin kinematics in seahorses. In Proceedings of Benelux Zoology 2014, Liege.
4. Kaashoek M, Pieters RPM, Voesenek CJ, Muijres FT, van Leeuwen JL & Henrion S (2014) Flow visualization reveals functional specialization of the upper and lower part of the seahorse its dorsal fin. In Proceedings of Benelux Zoology 2014, Liege.
5. Henrion S, Pieters RPM, Gussekloo SWS & ter Veld M (2014) Het zeepaard: model voor onderwatroboten. *Biotechniek* 53 (3). - p. 9 - 14.
6. Henrion S, Vercruyssen T, Müller UK (2014) Swimming, swarming and sensing. *Bio-inspired underwater robotics. Hydro international* 18 (2). - p. 4
7. Schipper H, Jaklofsky M & Henrion S. (2014) In-vivo injectie van contrast stoffen voor Röntgenstraling in zeepaarden. In Proceedings of Biotechnische dagen 2014, Egmond aan Zee.

MECHANICS, AERODYNAMICS AND ENERGETICS OF MOSQUITO FLIGHT

PROJECT AIM

By spreading diseases such as malaria, mosquitoes kill more than a million people every year. Although flight is important for both mosquito dispersal and host finding, surprisingly little is known about their flight performance. Very recently, we started a project on the biomechanics of mosquito flight using a unique multidisciplinary approach that applies high-tech engineering and scientific tools to measure and model the biomechanics and aerodynamics of mosquito flight. This research could lead to novel insight into the highly unsteady aerodynamics of fast oscillating wings, and could aid in the improvement of various mosquito control strategies.

PROGRESS

On August 2014 the project leader, dr ir Florian Muijres, initiated this research project in as part of his new appointment at the Experimental Zoology Group of Wageningen University. He acquired research funding from NWO in the form of a personal career development grant (ALW Vernieuwingsimpuls Veni), and he is now developing the experimental tools and facilities for his project. For example, he is building a wind tunnel for studying insect flight and has recently acquired a high-speed camera system that will be used to track mosquitoes in 3D.

DISSERTATIONS

-

SCIENTIFIC PUBLICATIONS

1. Muijres, F. T., Elzinga, M. J., Melis, J. M., & Dickinson, M. H. (2014). Flies Evade Looming Targets by Executing Rapid Visually Directed Banked Turns. *Science*, 344(6180), 172–177. doi:10.1126/science.1248955.
2. Muijres, F. T., & Dickinson, M. H. (2014). Bird flight: Fly with a little flap from your friends. *Nature*, 505, 295–296. doi:10.1038/505295a.
3. Muijres, F. T., Christoffer Johansson, L., Winter, Y., & Hedenström, A. (2014). Leading edge vortices in lesser long-nosed bats occurring at slow but not fast flight speeds. *Bioinspiration & Biomimetics*, 9(2), 025006. doi:10.1088/1748-3182/9/2/025006.
4. Johansson, L. C., Muijres, F. T., & Hedenström, A. (2014). The physics of animal locomotion. In L. Hansson & S. Åkesson (Eds.), *Animal Movement Across Scales* (pp. 232–252). Oxford, UK: Oxford University Press.

PROJECT LEADERS

FT Muijres

RESEARCH THEME

Complex dynamics of fluids

PARTICIPANTS

JL van Leeuwen (Chair)

R Pieters (Technician)

COOPERATIONS

Professor Michael Dickinson (CalTech, CA, USA), Professor Robert Dudley (UC Berkeley, CA, USA), Professor Hao Liu (Chiba University, Japan), Dr ir Bas van Oudheusden (TU Delft)

FUNDED

| | |
|----------------|-------|
| NWO ALW (Veni) | - |
| University | - |
| FOM | - |
| STW | - |
| NWO Other | 100 % |
| Industry | - |
| TNO | - |
| GTI | - |
| EU | - |
| Scholarships | - |

START OF THE PROJECT

2014

INFORMATION

F Muijres

0317 486977

florian.muijres@wur.nl

www.wageningenur.nl/en/Persons/dr.-FT-Florian-Muijres.htm



Prof.dr.ir. CGPH Schroën

Microtechnology, membranes and modelling: M3

Membranes (and other microstructures) can be used for various purposes, such as separation, which is the traditional application for membranes, but also for formation of emulsions, foams, and sprays. Within the food microtechnology group, all these aspects are investigated (together with technical assistants Jos Sewalt and Maurice Strubel), and modelling is used as a tool to gain fundamental insight in the underlying mechanisms, together with colleagues Ruud van der Sman and Maarten Schutyser. For specific information on projects, please consult the pages indicated below, and the PhD thesis section which holds completed projects.

MODELLING CROSS FLOW MICROFILTRATION: DESIGN FOR THE CONCENTRATION AND FRACTIONATION OF SUSPENSIONS

PROJECT AIM

This PhD project aims at modeling of particle behavior in flow through micro channels. During this process particles will migrate, and these effects can be used to facilitate amongst other microfiltration but also separation processes. Through detailed understanding of particle behavior we will design novel separation processes that are expected to be intrinsically more energy efficient than those that are currently available.

PROGRESS

Starting from experimental results obtained in previous research, we started with a simple system, i.e. a microchannel, through which a particle containing dispersion flows, and modelled this with Star CCM software. We were able to generate concentration gradients that resemble those that were experimentally found in literature. We now extend this system to include pores, and investigate the separation process.

DISSERTATIONS

-

SCIENTIFIC PUBLICATIONS

-

PROJECT LEADERS

K Schroën

RESEARCH THEME

Complex dynamics of fluids

PARTICIPANTS

I Drijer

COOPERATIONS

The project is part of the NanoNextNI program, and within that the water theme. We cooperate with UTwente, and Stork Veco.

FUNDED

| | |
|--------------|-------|
| NanoNextN1 | |
| University | - |
| FOM | - |
| STW | - |
| NWO Other | 100 % |
| Industry | - |
| TNO | - |
| GTI | - |
| EU | - |
| Scholarships | - |

START OF THE PROJECT

2012

INFORMATION

K Schroën

0317 483396

karin.schroen@wur.nl

<http://www.wageningenur.nl/en/>

Expertise-Services/Chair-groups/

Agrotechnology-and-Food-Sciences/

Food-Process-Engineering/

Research/Food-microtechnology.htm



Prof.dr. LRM Maas

Research in this theme focuses on the interactions between the water motion, sediment transport and bottom changes in coastal seas and estuaries. Both sandy and mud-dominated coastal systems are investigated. The following approaches are used to gain more understanding of hydrodynamic and morphodynamic processes: collection and analysis of field observations, simulations with complex numerical models and interpretation of these results, development and analysis of idealized mathematical models.

OBSERVATIONAL STUDY OF THE EQUATORIAL BOUNDARY LAYER

PROJECT AIM

Observations show that ocean dynamics distinctly differs in a narrow zone of about ± 2 degree near the equator compared to off-equatorial regions. Geometric focusing of internal waves, and strictly equatorial features (i.e. horizontal component of Coriolis force), traditionally neglected, might have an important effect on the dynamics of the low latitudes, which we aim to illuminate by (1) 3D ray tracing study of internal wave beams in fully enclosed (geophysical) domains; (2) a set of ad hoc observations in the West Equatorial Atlantic Ocean; (3) development of a consistent theoretical framework for interpretation of linear equatorial dynamics.

PROGRESS

A 3D ray tracing algorithm for inertial waves has been developed and applied to the spherical shell and to the full sphere geometry to investigate the wave behavior in fully enclosed, geophysically relevant domains. In the shell, the occurrence of meridional internal wave attractors dominates in the equatorial band. In the full sphere geometry, where analytical solutions for the internal wave problem are known, results from the two methods have been compared, revealing comforting consistency but also unexpected puzzles. In situ oceanographic data from the West Equatorial Atlantic Ocean are currently under analysis in order to characterize the intermediate-to-deep equatorial wave and current field, and compare it, when possible, with the gained theoretical understanding.

DISSERTATIONS

-

SCIENTIFIC PUBLICATIONS

1. A. Rabitti and L. R. M. Maas. Inertial wave rays in rotating spherical fluid domains. *Journal of Fluid Mechanics*, 758: pg 621 – 654, 2014.

PROJECT LEADERS

LRM Maas

RESEARCH THEME

Complex dynamics of fluids

PARTICIPANTS

T Gerkema, H van Haren, A Rabitti

COOPERATIONS

NIOZ, UU

FUNDED

| | |
|--------------|-------|
| NWO | |
| University | - |
| FOM | - |
| STW | - |
| NWO Other | 100 % |
| Industry | - |
| TNO | - |
| GTI | - |
| EU | - |
| Scholarships | - |

START OF THE PROJECT

2009

INFORMATION

LRM Maas

0222 369419

leo.maas@nioz.nl

www.nioz.nl

DYNAMICAL OCEANOGRAPHY AT IMAU



Prof.dr.ir. HA Dijkstra

In my group, we study the role of the ocean circulation in the variability of the climate system and the processes controlling the large-scale ocean circulation.

Focus of work in on the path changes of ocean western boundary currents (such as the Gulf Stream in the Atlantic, the Kuroshio in the Pacific and the Agulhas near South Africa), the El Nino/Southern Oscillation phenomenon in the Pacific and the North Atlantic Multidecadal variability. Both theory development and (high-resolution) model simulation are used to understand these phenomena and our favorite framework to analyse the complex behavior of ocean flows is that provided by stochastic dynamical systems theory.

PREDICTABILITY OF KUROSHIO CURRENT PATH TRANSITIONS

PROJECT AIM

Our objectives are (i) to develop a unifying theory of the Kuroshio path variability, (ii) to assess the decadal time scale predictability of these path transitions, (iii) to determine the effects of the large-scale barotropic instabilities, meso-scale eddies and wind-stress variations on this predictability and (iv) to study of impact of different observational data on the prediction skill of the models used.

PROGRESS

The study on the transitions between paths of the Kuroshio using a network approach has been completed [1]. Intrinsic variability of the Antarctic Circumpolar Current was considered in [2]. A review on the physics of the Kuroshio Current and its predictability has been published in [3].

DISSERTATIONS

-

SCIENTIFIC PUBLICATIONS

1. J. Viebahn and H. A. Dijkstra, Critical transition analysis of the deterministic wind-driven ocean circulation, A flux-based network approach, *Int. J. Bifurcation Chaos*, in 24, 1430007-1 1430007-32, (2014).
2. G. Sgubin, S. Pierini and H. A. Dijkstra, Intrinsic variability of the Antarctic Circumpolar Current System: low- and high-frequency fluctuations of the Argentine Basin flow, *Ocean Science*, 10, 201-213, (2014).
3. Pierini, S., H. A. Dijkstra and Mu Mu, Intrinsic low-frequency variability and predictability of the Kuroshio current and of its extension, *Advances in Oceanography and Limnology*, 5, No. 2, 79-122, (2014).

PROJECT LEADERS

HA Dijkstra

RESEARCH THEME

Complex dynamics of fluids

PARTICIPANTS

J Viebahn

COOPERATIONS

Dr. Fred Wubs (RUG), Prof. T.

Sapsis (MIT, MA, USA), Prof. Mu Mu

(IOCAS, Qingdao, China), Prof. S.

Pierini (Univ. Naples, Naples, Italy)

FUNDED

NWO-EW (COMPLEXITY)

University -

FOM -

STW -

NWO Other 100 %

Industry -

TNO -

GTI -

EU -

Scholarships -

START OF THE PROJECT

2011

INFORMATION

HA Dijkstra

H.A.Dijkstra@uu.nl

WHO & WHERE



Mechanical Engineering - Mekelweg 2 - 2628 CD Delft

- ◆ Prof.dr.ir. J Westerweel 015 278 6887 j.westerweel@tudelft.nl
- Prof.dr. DJEM Roekaerts 015 278 2470 d.j.e.m.roekaerts@tudelft.nl
- Prof.dr.ir. RAWM Henkes 015 278 1323 r.a.w.m.henkes@tudelft.nl
- Prof.dr. JCR Hunt 015 278 2904 jcrh@cpom.ucl.ac.uk
- Prof.dr.ir. G Ooms 015 278 1176 g.ooms@tudelft.nl
- Prof.dr.ir. B Eckhardt 015 278 2904 bruno.eckhardt@physik.uni-marburg.de
- ◆ Prof.dr.ir. BJ Boersma 015 278 7979 b.j.boersma@tudelft.nl

Maritime Engineering - Mekelweg 2 - 2628 CD Delft

- ◆ Prof.dr.ir. RHM Huijsmans 015 278 2889 r.h.m.huijsmans@tudelft.nl
- Prof.dr.ir. TJC van Terwisga 015 278 6860 t.v.terwisga@tudelft.nl
- ◆ Prof.dr.ir. C van Rhee 015 278 3973 c.vanrhee@tudelft.nl

Applied Mathematics - Mekelweg 4 - 2628 CD Delft

- ◆ Prof.dr.ir. C Vuik 015 278 5530 c.vuik@tudelft.nl
- ◆ Prof.dr.ir. AW Heemink 015 278 5813 a.w.heemink@tudelft.nl

Chemical Engineering - Julianalaan 136 - 2628 BW Delft

- ◆ Prof.dr.ir. CR Kleijn 015 278 2835 c.r.kleijn@tudelft.nl
- Prof.dr. RF Mudde 015 278 2834 r.f.mudde@tudelft.nl
- Prof.dr.ir. HEA van den Akker 015 278 5000 h.e.a.vandenakker@tudelft.nl
- Prof.dr.ir. S Sundaresan 015 278 5000 sundar@princeton.edu
- Prof.dr.ir. J Derksen 015 278 6419 j.j.derksen@tudelft.nl
- ◆ Prof.dr.ir. MT Kreutzer 015 278 9084 m.t.kreutzer@tudelft.nl

Radiation Science and Technology - Mekelweg 15 - 2629 JB Delft

- ◆ Prof.dr.ir. THJJ van der Hagen/Rohde 015 278 2105 t.h.j.vanderhagen@tudelft.nl

Aerospace Engineering - Kluyverweg 2 - 2600 GB Delft

- ◆ Prof.dr.ir. H Bijl 015 278 5373 h.bijl@tudelft.nl
- Prof.dr.ir. F Scarano 015 278 9111 f.scarano@tudelft.nl

Civil Engineering and Geosciences - Stevinweg 1 - 2628 CN Delft

- ◆ Prof.dr.ir. AJHM Reniers 015 278 4778 a.j.h.m.reniers@tudelft.nl
- Prof.dr.ir. J Pietrzak 015 278 9455 j.d.pietrzak@tudelft.nl
- Prof.dr.ir. WSJ Uijtewaal 015 278 1371 w.s.j.ujtewaal@tudelft.nl
- ◆ Prof.dr. HJJ Jonker 015 278 6157 h.j.j.jonker@tudelft.nl
- Prof.dr. AP Siebesma 015 278 4720 a.p.siebesma@tudelft.nl

Applied Physics

- ◆ Prof.dr.ir. AA Darhuber 040 247 4499 a.a.darhuber@tue.nl
- Prof.dr.ir. J Snoeijer 040 247 9111 j.h.snoeijer@tue.nl
- ◆ Prof.dr. HJH Clercx 040 247 2680 h.j.h.clercx@tue.nl
- Prof.dr.ir. GJF van Heijst 040 247 2722 g.j.f.v.heijst@tue.nl
- Prof.dr.ir. F Toschi 040 247 3911 f.toschi@tue.nl
- Prof.dr.ir. BJ Geurts 040 247 4285 b.j.geurts@tue.nl
- ◆ Prof.dr.ir. OCG Adan 040 247 3398 o.c.g.adan@tue.nl
- ◆ Prof.dr.ir. GMW Kroesen 040 247 4357 g.m.w.kroesen@tue.nl

Mechanical Engineering

- ◆ Prof.dr. RJM Bastiaans 040 247 4836 r.j.m.bastiaans@tue.nl
- Prof.dr. LPH de Goey 040 247 2938 l.p.h.d.goey@tue.nl
- Prof.dr. BH Johansson 040 247 3731 b.johansson@tue.nl
- ◆ Prof.dr. JGM Kuerten 040 247 2362 j.g.m.kuerten@tue.nl
- Prof.dr. M Golombok 040 247 3664 m.golombok@tue.nl
- ◆ Prof.dr.ir. DMJ Smeulders 040 247 2140 d.m.j.smeulders@tue.nl
- Prof.dr.ir. AA van Steenhoven 040 247 2132 a.a.v.steenhoven@tue.nl
- Prof.dr. HA Zondag 040 247 2719 h.a.zondag@tue.nl
- ◆ Prof.dr.ir. JMJ den Toonder 040 247 2987 j.m.j.d.toonder@tue.nl
- ◆ Prof.dr.ir. EH van Brummelen 040 247 5470 e.h.v.brummelen@tue.nl

Biomedical Engineering

- ◆ Prof.dr.ir. FN van de Vosse 040 247 4218 f.n.v.d.vosse@tue.nl

Mathematics and Computer Science

- ◆ Prof.dr.ir. B Koren 040 247 2080 b.koren@tue.nl
- Prof.dr.ir. F Toschi 040 247 3911 f.toschi@tue.nl
- ◆ Prof.dr.ir. CJ van Duijn 040 247 2855 c.j.v.duijn@tue.nl
- Prof.dr. JJM Slot 040 247 2184 j.j.m.slot@tue.nl

Chemical Engineering and Chemistry

- ◆ Prof.dr.ir. JAM Kuipers 040 247 4158 j.a.m.kuipers@tue.nl
- Prof.dr.ir. M van Sint Annaland 040 247 2241 m.v.sintannaland@tue.nl

Applied Physics

- ◆ Prof.dr. WJ Briels 053 489 2947 w.j.briels@utwente.nl
- ◆ Prof.dr. D Lohse 053 489 8076 d.lohse@utwente.nl
- Prof.dr. D van de Meer 053 489 2387 d.vandermeer@utwente.nl
- Prof.dr. J Snoeijer 053 489 3085 j.h.snoeijer@utwente.nl
- Prof.dr. M Versluis 053 489 6824 m.versluis@utwente.nl
- Prof.dr. J Harting 053 489 4829 j.harting@tue.nl
- Prof.dr.ir. X Zhang 053 489 5604 xuehua.zhang@utwente.nl
- Prof.dr.ir. JF Dijkstra 06 2334 1331 j.f.dijkstra@ziggo.nl
- Prof.dr.ir. L van Wijngaarden 053 489 3086 l.vanwijngaarden@tnw.utwente.nl
- Prof.dr. A Prosperetti 053 489 9111 prosperetti@jhu.edu
- Prof.dr. R Verzicco 053 489 2470 r.verzicco@utwente.nl
- ◆ Prof.dr. F Mugele 053 489 3094 f.mugele@utwente.nl

Chemical Engineering

◆ Prof.dr.ir. RGH Lammertink 053 489 2063 r.g.h.lammertink@utwente.nl

Mathematical Sciences

◆ Prof.dr.ir. EWC van Groesen 053 489 3413 e.w.c.vangroesen@utwente.nl
◆ Prof.dr.ir. JWW van der Vegt 053 489 5628 j.j.w.vandervegt@utwente.nl
Prof.dr.ir. O Bokhove 053 489 3408 o.bokhove@utwente.nl
◆ Prof.dr.ir. BJ Geurts 053 489 4125 b.j.geurts@utwente.nl
Prof.dr. JGM Kuerten 053 489 3408 j.g.m.kuerten@utwente.nl
Prof.dr. HJH Clercx 053 489 3408 h.j.h.clercx@utwente.nl

Mechanical Engineering

◆ Prof.dr.ir. CH Venner 053 489 2488 c.h.venner@utwente.nl
Prof.dr.ir. HWM Hoeijmakers 053 489 4838 h.w.m.hoeijmakers@utwente.nl
Prof.dr.ir. A Hirschberg 040 247 2163 a.hirschberg@tue.nl
◆ Prof.dr.ir. ThH van der Meer 053 489 2562 t.h.vandermeer@utwente.nl
◆ Prof.dr. S Luding 053 489 4212 s.luding@ctw.utwente.nl

Water Engineering and Management

◆ Prof.dr. SJMH Hulscher 053 489 4256 s.j.m.h.hulscher@utwente.nl

RUG | 050 363 9111 | PO Box 800 - 9700 AV Groningen

Mathematics

◆ Prof.dr.ir. RWCP Verstappen 050 363 3958 r.w.c.p.verstappen@rug.nl

WUR | 0317 477 477 | PO Box 9101 - 6701 BH Wageningen

Experimental Zoology

◆ Prof.dr.ir. JL van Leeuwen 0317 482267 johan.vanleeuwen@wur.nl

Agrotechnology and Food Sciences

◆ Prof.dr.ir. CGPH Schroen 0317 483396 karin.schroen@wur.nl

UU | 030 253 9111 | PO Box 80125 - 3508 TC Utrecht

Physics and Astronomy

◆ Prof.dr. LRM Maas 0222 369 419 maas@nioz.nl
◆ Prof.dr.ir. HA Dijkstra 030 253 5441 h.a.dijkstra@uu.nl

Board of Directors

| | | |
|--|--------------|-----------------------------|
| Prof.dr.ir. G Lodewijks (TUD, Chairman) | 015 278 9111 | g.lodewijks@tudelft.nl |
| Ir. AJ Dalhuijsen (VSL) | 015 269 1500 | adalhuijsen@vsl.nl |
| Prof.dr.ir. CR Kleijn (TUD) | 015 278 2835 | c.r.kleijn@tudelft.nl |
| Prof.dr.ir. JJW van der Vegt (UT) (till July 2014) | 053 489 5628 | j.j.w.vandervegt@utwente.nl |
| Prof.dr.ir. GMW Kroesen (TUE) | 040 247 4357 | g.m.w.kroesen@tue.nl |
| Prof.dr.ir. JWM Hilgenkamp (UT) (from July 2014) | 053 489 2806 | j.w.m.hilgenkamp@utwente.nl |

Management Team

| | | |
|-------------------------------------|--------------|-------------------------|
| Prof.dr.ir. AA van Steenhoven (TUE) | 040 247 2140 | a.a.v.steenhoven@tue.nl |
| Prof.dr. D Lohse (UT) | 053 489 8076 | d.lohse@utwente.nl |
| Prof.dr.ir. J Westerweel (TUD) | 015 278 6887 | j.westerweel@tudelft.nl |

Industrial Board

| | | |
|---|---------------|-------------------------------|
| Ir. A van Berkel (TNO Science & Industry) | 055 549 3759 | arij.vanberkel@tno.nl |
| Ir. AJ Dalhuijsen (VSL) | 015 269 1500 | adalhuijsen@vsl.nl |
| Dr. E Pelssers (Philips) | 040 291 0926 | eduard.pelssers@philips.com |
| Dr.ir. TWJ Peeters (Tatasteel) | 0251 495018 | tim.peeters@tatasteel.com |
| Ir. A van Garrel (ECN) | 0224 564170 | vangarrel@ecn.nl |
| Ir. G Hommersom (Dow Benelux) | 0115 67 4102 | ghommersom@dow.com |
| Dr.ir. J Janssen (Unilever) | 010 460 6324 | jo.janssen@unilever.com |
| Ir. J de jong (DSM) | 046 476 ????? | jelle.jong-de@dsm.com |
| Ir. JJ Meerman (Teijin Aramid) | 088 268 9367 | hans.meerman@teijinaramid.com |
| Prof.dr.ir. AE Mynett (WL) | 015 285 8580 | a.mynett@unesco-ihe.org |
| Dr. B Oskam (NLR) | 020 511 3357 | oskam@nlr.nl |
| Dr.ir. HJ Prins (Marin) | 0317 493 405 | h.j.prins@marin.nl |
| Ir. H Reinten (Oce) | 077 359 4061 | hans.reinten@oce.com |
| Ir. M Riepen (ASML) | 040 268 3000 | michel.riepen@asml.nl |
| Ir. G Saccoccia (ESA/ESTEC) | 071 565 4781 | giorgio.saccoccia@esa.int |
| Ir. P Veenstra (Shell) | 020 630 3384 | peter.veenstra@shell.com |
| Ir. Veraar (TNO Defence and Safety) | 015 284 3395 | ronald.veraar@tno.nl |
| Dr.ir. FC Visser (Flowserve) | 076 502 8311 | fvisser@flowserve.com |
| Ir. GJN Alberts (TNO Science & Industry) | 088 866 0677 | garrelt.alberts@tno.nl |
| Dr.ir. B Vreman (AKZO-Nobel) | 026 366 9440 | bert.vreman@akzonobel.com |
| Dr. J Longo (ESA/ESTEC) | 071 565 6662 | jose.longo@esa.int |
| Ir. M Roest (VORTECH) | 015 285 0127 | mark.roest@vortech.nl |
| Dr. L Korstanje (STW) | 030 600 1300 | l.korstanje@stw.nl |
| Ir. J Pennekamp | 088 335 8273 | johan.pennekamp@deltares.nl |

PhD Students Contact Group

TUD

| | | |
|-----------------|--------------|-----------------------------|
| AJ Greidanus | 015 278 9111 | a.j.greidanus@tudelft.nl |
| M Olivero | 015 278 9479 | m.olivero@tudelft.nl |
| JSB van Zwieten | 015 278 9111 | j.s.b.vanzwieten@tudelft.nl |
| PB Smit | 015 278 9111 | p.b.smit@tudelft.nl |
| X Yang | 015 278 9111 | xiaogang.yang@tudelft.nl |
| D Violato | 015 278 5902 | d.violato@tudelft.nl |

TUE

| | | |
|---------------|--------------|------------------------|
| HM Slagter | 040 247 3685 | h.m.slagter@tue.nl |
| RPC Zegers | 040 247 5689 | r.p.c.zegers@tue.nl |
| CWJ Berendsen | 040 247 9111 | c.w.j.berendsen@tue.nl |

UT

| | | |
|--------------|--------------|-------------------------------|
| B Bera | 053 489 9111 | b.bera@utwente.nl |
| H Gelderblom | 053 489 9111 | h.gelderblom@tnw.utwente.nl |
| HJJ Staat | 053 489 9111 | h.j.j.staat@utwente.nl |
| W Kranenburg | 053 489 2959 | w.m.kranenburg@ctw.utwente.nl |
| BJ Konijn | 053 489 9111 | b.j.konijn@utwente.nl |
| AA Verbeek | 053 489 2507 | a.a.verbeek@utwente.nl |

RUG

| | | |
|--------------------|--------------|-----------------------------|
| HJL van der Heiden | 050 363 3970 | h.j.l.van.der.heiden@rug.nl |
|--------------------|--------------|-----------------------------|

JM Burgerscentrum (the Netherlands)

Prof.dr.ir. GJF van Heijst, scientific director 015 278 1176 g.j.f.v.heijst@tue.nl
I Hoekstein-Philips, secretariat 015 278 3216 jmburgerscentrum@tudelft.nl
Mekelweg 2
2628 CD Delft

Burgers Program Maryland

James M Wallace, Professor, Dept. of Mechanical Engineering
www.eng.umd.edu/~wallace
Gemstone Program Director
www.gemstone.umd.edu/
Chair, Burgers Program for Fluid Dynamics
www.burgers.umd.edu/
T 301 314 6695
F 301 314 8469
E wallace@eng.umd.edu

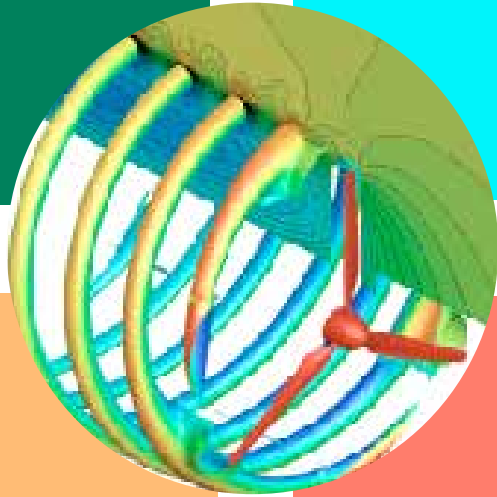

JMBC ANNUAL REPORT & RESEARCH PROGRAMME
2014-2015